

ONKYO SERVICE MANUAL

STEREO CASSETTE TAPE DECK MODEL TA-2200

Black model

UD,UD [®]	120V AC, 60Hz
UG	220V AC, 50Hz
UW	120 or 220V AC, 50/60Hz
UQA, UQB	240V AC, 50Hz

SAFETY-RELATED COMPONENT WARNING!!

COMPONENTS IDENTIFIED BY MARK \triangle ON THE SCHEMATIC DIAGRAM AND IN THE PARTS LIST ARE CRITICAL FOR RISK OF FIRE AND ELECTRIC SHOCK. REPLACE THESE COMPONENTS WITH ONKYO PARTS WHOSE PARTS NUMBERS APPEAR AS SHOWN IN THIS MANUAL.

MAKE LEAKAGE-CURRENT OR RESISTANCE MEASUREMENTS TO DETERMINE THAT EXPOSED PARTS ARE ACCEPTABLY INSULATED FROM THE SUPPLY CIRCUIT BEFORE RETURNING THE APPLIANCE TO THE CUSTOMER.

SPECIFICATIONS

Track Format: 4-tracks, 2-channels
Erasing System: AC erase
Tape Speed: 4.8 cm/sec. (1-7/8 i.p.s.)
Wow and Flutter: 0.07% (WRMS)

Frequency Response: 20–17,000Hz (Normal)
(30–16,000Hz \pm 3dB)
20–18,000Hz (High)
(30–17,000Hz \pm 3dB)
20–19,000Hz (Metal)
(30–18,000Hz \pm 3dB)

S/N Ratio: 58dB (metal tape, Dolby NR off)
A noise reduction of 10dB above 5kHz and 5dB at 1kHz is possible with Dolby B NR. A noisy reduction of 20dB at 5kHz is possible with Dolby C NR.

Input Jacks: Line IN: 2
Input sensitivity: 60mV
Input impedance: 50kohms

Outputs: Line OUT: 2
Standard output level: 500mV (0dB)
Optimum load impedance: over 50 kohms
Headphone jack: 1
Optimum load impedance: 8 to 200 ohms

Motors: DC servo motor: 1
DC motor: 1

Heads: REC/PB: Special Hard Permalloy x 1;
Erase head: Ferrite x 1

Power Supply Rating: U.K. and Australian models:
AC 240V, 50Hz
U.S.A. and Canadian models:
AC 120V, 60Hz
Worldwide models:
AC 120V and 220V switchable, 50/60Hz

Power Consumption: 19 watts

Dimensions: 435(W) x 122(H) x 262(D) mm
(17-1/8" x 4-13/16" x 10-15/16")

Weight: 4.4 kg. (9.7 lbs.)

RC-146T Remote Control Transmitter (U.S.A. and Canadian models only)

Transmitter: Infrared
Signal Range: Approx. 5 meters (16 feet)
Power Supply: Two AAA batteries
Dimensions: 38(W) x 150(H) x 15.3(D) mm
(1-1/2" x 5-7/8" x 5/8")
Weight: 62 grams (2.2 oz.) (including batteries)

Specifications and external appearance are subject to change without notice because of product improvements.



SERVICE PROCEDURES

1. Replacement of power supply cord

There are two power supply cord outlets on the strainrelief. Insert them in prescribed direction to ensure safety. AS-UC-3 (UD<120V> model) should be inserted lengthwise and other types of cords should be inserted horizontally.

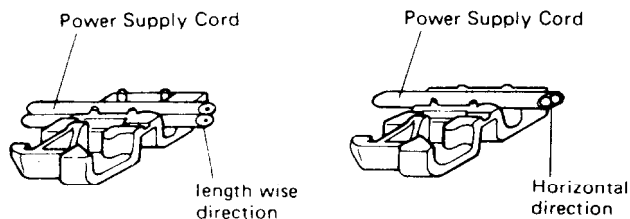

2. Insulating resistance measurement

Connect the insulating-resistance tester between the plug of power supply cord and chassis.

Specifications: 500V more than 10MΩ

HX PRO CIRCUIT OPERATION EXPLANATION

1. Regarding recording frequency characteristic and bias

Ordinarily, if the recording bias current is increased, REC/PB frequency response level in the high frequency region (about 10KHz and above) drops, and if the bias is decreased, the response rises.

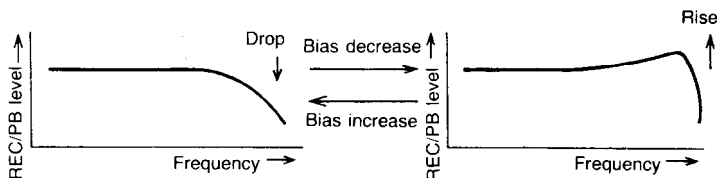

2. Regarding the basic operation of HX PRO (Refer to Fig. 1)

The HX PRO uses the μ PC1297CA IC. The operation is in accordance with the following.

- 1) At (a), the recording bias is added onto the audio signal, and the recording signal is detected. This is the same as the recording head recording the signal on the tape.
- 2) The signal of 1) preserves the frequency response with the integrated circuit of (b).

$$\text{Frequency} = \frac{R433 + R431}{2\pi \times C423 \times R433 \times R431} \quad (2.1)$$

By means of the frequency of Fig. 1, the frequency which is effective from the beginning is determined. In the ordinary situation, this is half the audio band (10KHz), (10KHz ~ 7.5KHz).

- 3) At (c), in order to use the affected waveform after-ward, absolute detection is carried out.

- 4) At (d), the waveform peak value is detected. The output becomes the peak DC voltage.
- 5) At (e), the standard voltage and the voltage of (4) are compared.
- 6) With the output of (e), the frequency generation level is controlled (voltage controlled amplifier). That is, the bias size is varied.
- 7) Summing up 1) ~ 6):

At (a), the time constant (frequency) that is detected in the recording signal is preserved, and above a certain frequency and above a certain level, the VCA controls the bias current by causing its reduction. When this is done, in the manner shown in the explanation of Item 1 above, the frequency high region is raised. With this control, the audio signal is instantaneously dealt with.

3. Regarding the operating conditions of the HX PRO

- 1) With equation (2. 1) noted above, the effect begins at the frequency thus determined.
- 2) Above a certain level the effect begins.
(Substantially 0 dB: In the vicinity of 500mV line out)
The audio signal component level is dependent upon the waveform after point (c).

HX PRO BLOCK DIAGRAM

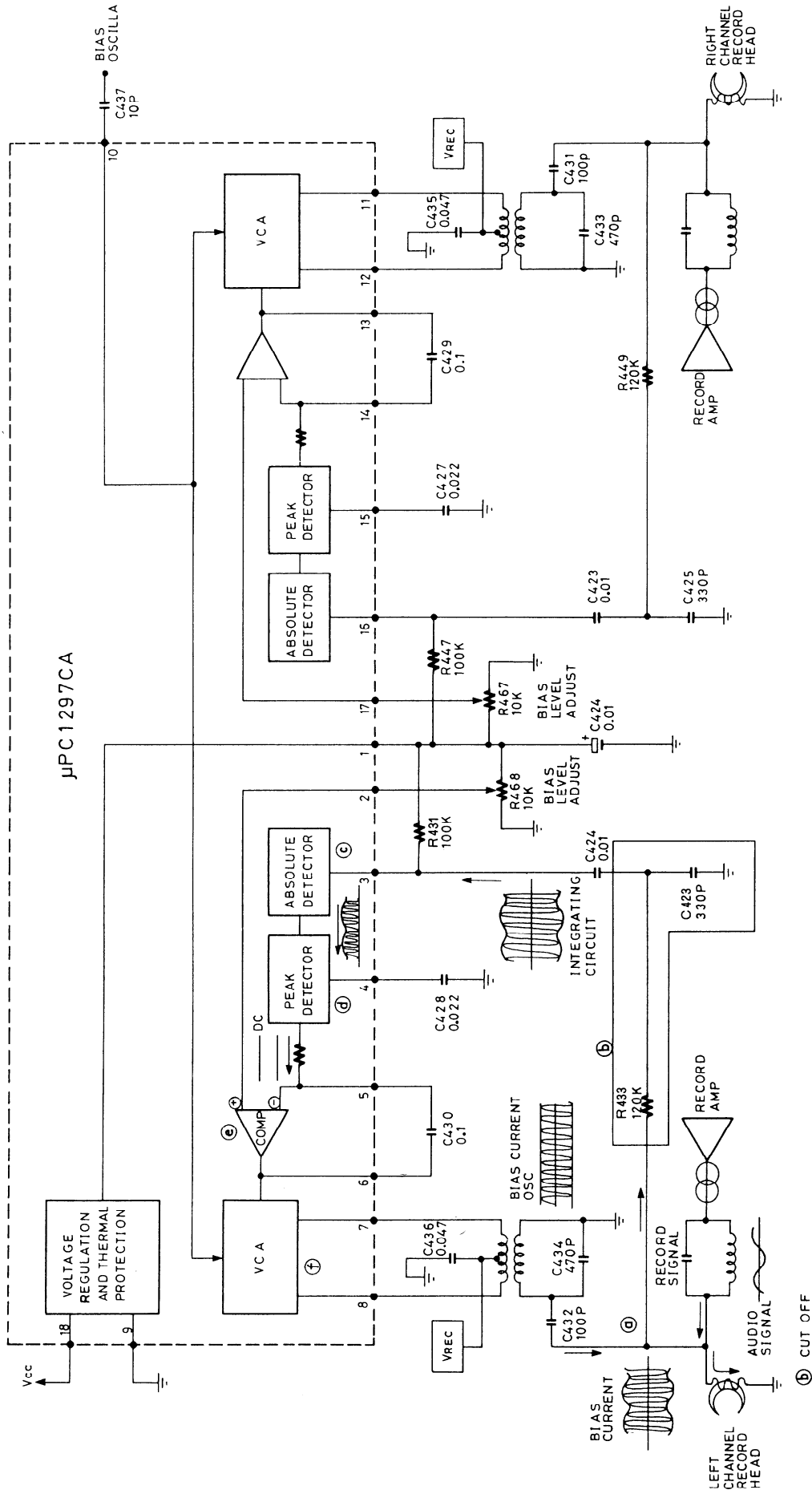
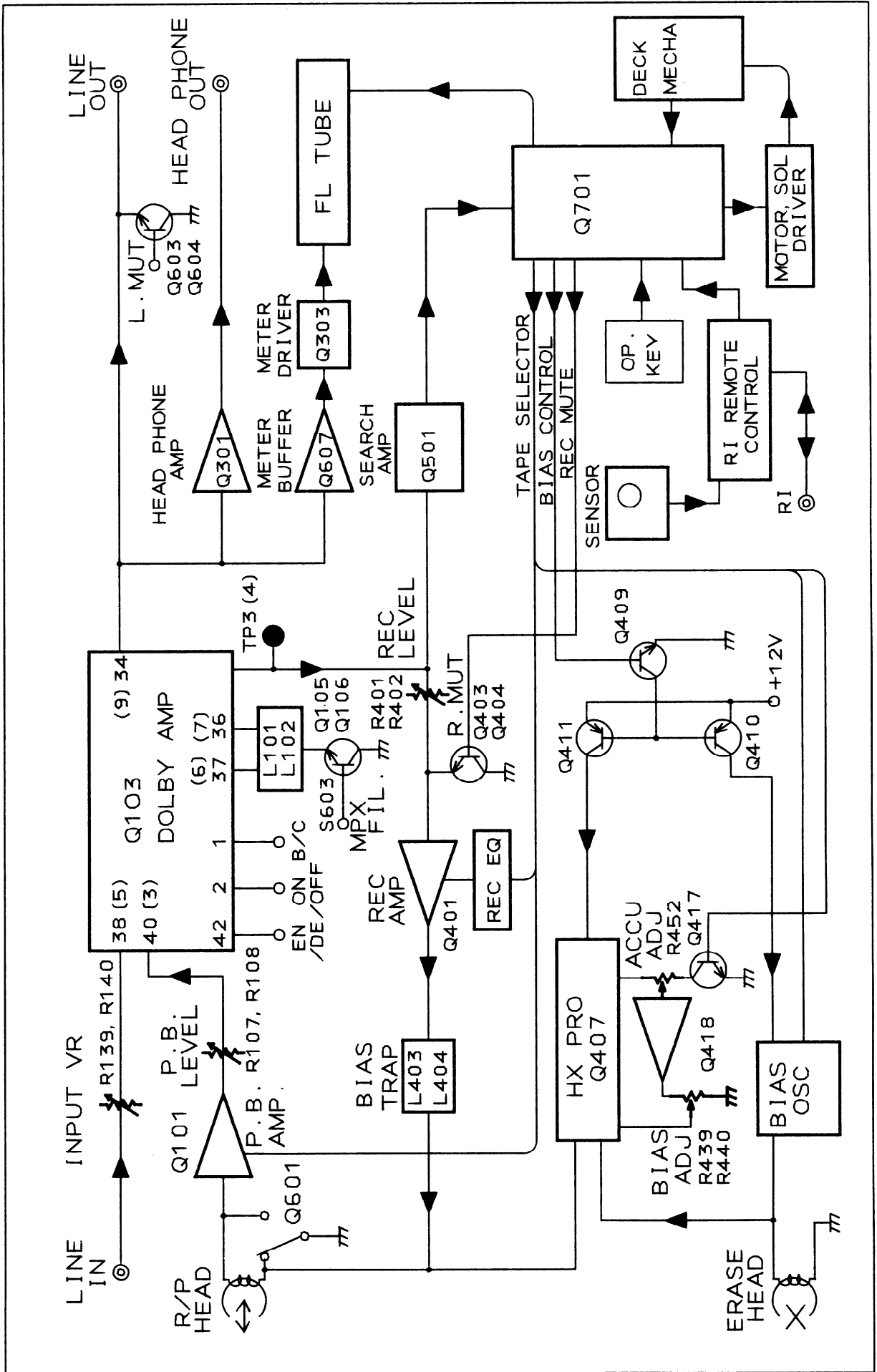

Fig. 1

BLOCK DIAGRAM



IC BLOCK DIAGRAM

NCHC-3205 (P.B AMP)

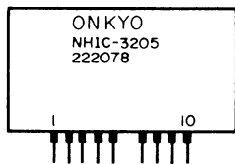
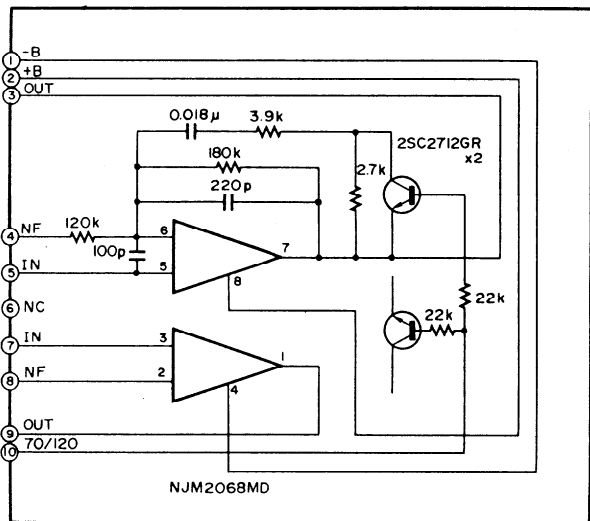

CX20187 (DOLBY N.R)

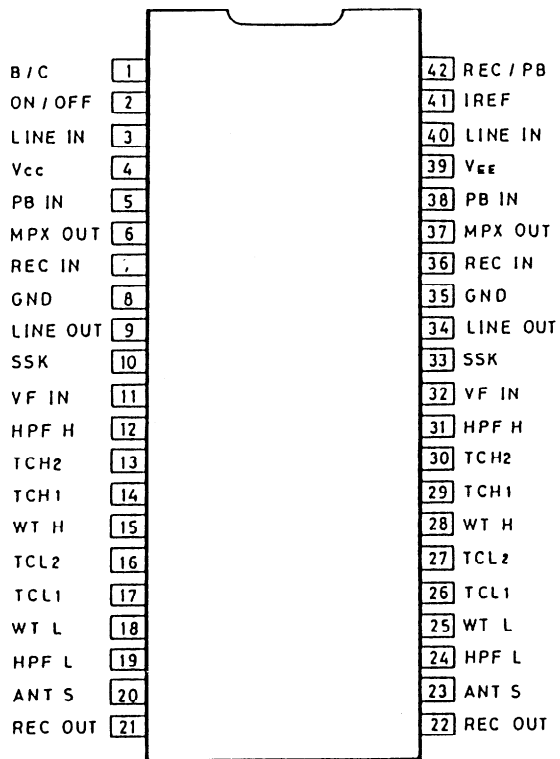

BA6810S (METER DRIVE)

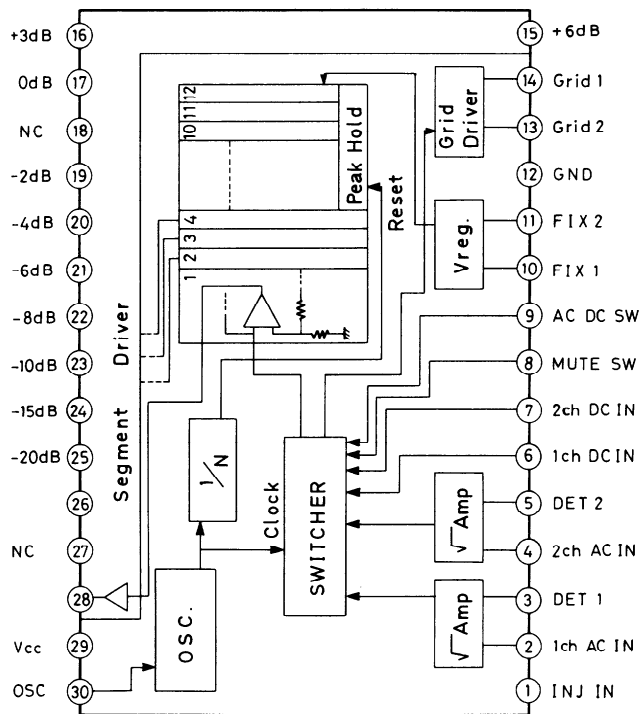

TA-7291S (MOTOR DRIVE)

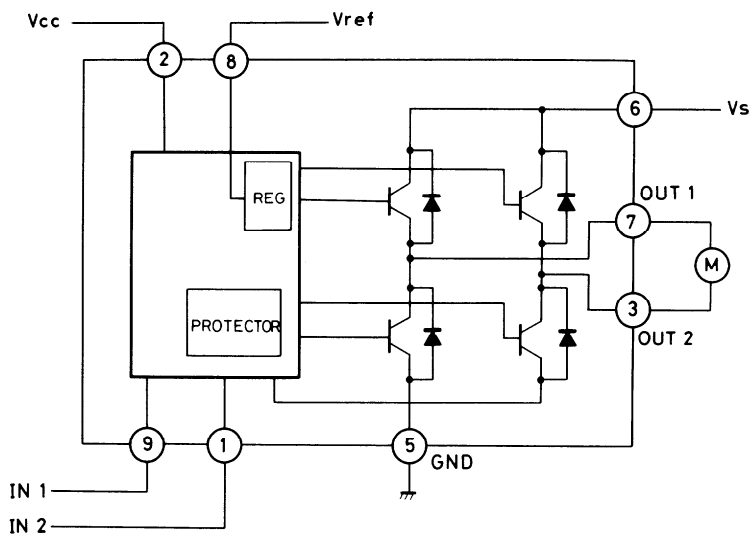

INPUT		OUTPUT		MODE
IN 1	IN 2	OUT 1	OUT 2	
0	0	∞	∞	STOP
1	0	H	L	CW/CCW
0	1	L	H	CCW/CW
1	1	L	L	BRAKE

MICRO COMPUTER (HD-614048SJ49)

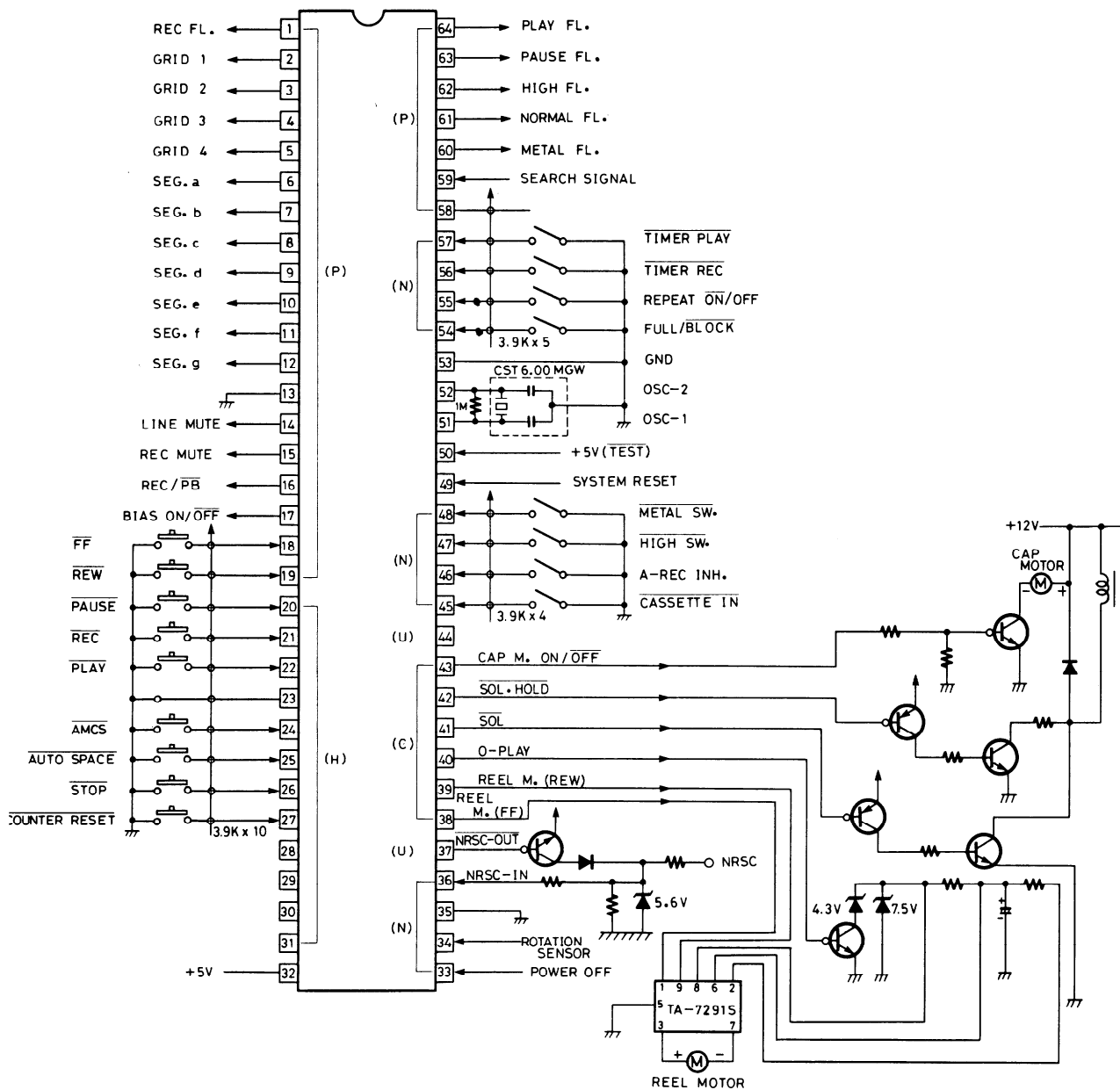

MICRO COMPUTER

Terminal Name and Function

Pin No.	Name	Function
1	REC FL	Lights up the FL tube REC display. HIGH = Light up.
2 ~ 5	GRID 1 ~ 4	Lights up the FL tube grid 1 ~ 4. HIGH = Light up.
6 ~ 12	SEG. a ~ g	Lights up the FL tube segments a ~ g. HIGH = Light up.
14	LINE MUTE	Line muting output: HIGH = Muting ON/LOW = Muting OFF.
15	REC MUTE	Record muting output: HIGH = Muting ON/LOW = Muting OFF.
16	REC/PB	Record/playback selector output: HIGH = Record/LOW = Playback.
17	BIAS ON/OFF	Recording bias oscillator control output: HIGH = Bias ON/LOW = Bias OFF.
18	FF	FF key input
19	REW	REW key input
20	PAUSE	PAUSE key input: input accepted in STOP, Recording, Playback and Autospace modes.
21	REC	REC key input: effected by simultaneously pressing both PAUSE KEY and PLAY KEY.
22	PLAY	PLAY key input
24	AMCS	AMCS key input (music selection)
25	AUTO SPACE	AUTOSPACE key input: input accepted from REC and REC/PAUSE modes.
26	STOP	STOP key input
27	COUNTER RESET	COUNTER RESET key input: sets electronic counter to '0000'.
32	Vcc	PC power supply.
33	POWER OFF	POWER OFF signal input: HIGH = POWER OFF
34	ROTATION SENSOR	Pulse input for tape counter, tape end sensor and BLOCK REPEAT time.
38	REEL M. (FF)	Reel motor output (FF direction). Set to HIGH to rotate in FF direction.
39	REEL M. (REW)	Reel motor output (REW direction). Set to HIGH to rotate in REW direction.
40	0-PLAY	Reel motor rotation speed selection output. HIGH = PLAY/LOW = FF/REW.
41	SOL	Triggers the solenoid. LOW = Trigger.
42	SOL.HOLD	Holds solenoid. LOW = Hold.
43	CAP M. ON/OFF	Capstan motor ON/OFF output. HIGH = ON/LOW = OFF.
46, 58	REC INH. (A)	Record inhibit tab (A side) detection input. HIGH = Record inhibit tab broken.
47	HIGH SW.	High position tape detection input. LOW = High position tape.
48	METAL SW.	Metal tape detection input. LOW = Metal tape.
49	RESET	PC system reset.
50	TEST	Link to + Vcc
51, 52	OSC1, OSC2	Internal oscillator input terminal.
53	GND	Grounding
54	FULL/BLOCK	FULL REPEAT or BLOCK REPEAT selection input. HIGH = FULL REPEAT/LOW = BLOCK REPEAT.
55	REPEAT ON/OFF	REPEAT ON/OFF selection input. HIGH = OFF/LOW = ON.
56	TIMER REC	TIMER REC switch. HIGH = OFF/LOW = ON.
57	TIMER PLAY	TIMER PLAY switch. HIGH = OFF/LOW = ON.
59	SEARCH SIGNAL	Signal input for AMCS (music selection). HIGH = Signal detected.
60	METAL FL.	Tape selector output. HIGH output = Metal tape.

Pin No.	Name	Function
61	NORMAL FL.	Tape selector output. HIGH output = No tape or normal tape.
62	HIGH FL.	Tape selector output. HIGH output = High position tape.
63	PAUSE FL.	Lights up FL tube PAUSE display. HIGH = Light up.
64	PLAY FL.	Lights up FL tube PLAY display. HIGH = Light up.

REPEAT (FULL or BLOCK) and AMCS.

The FULL REPEAT function enables five plays of one full side of the tape currently on the machine. It operates such that when FULL REPEAT has been selected and the end of the tape is sensed during PLAY or rewind then the machine will automatically enter this mode. Where the end of the tape is sensed and this mode entered during play, then the latest completed play will be deemed to be the first play and the tape will then be played four more times. The use of the PAUSE or its release during the course of a FULL REPEAT will not have any effect on the subsequent number of repeats. (see Fig. 2)

The BLOCK REPEAT function enables five consecutive plays of the section between any two selected points. The starting point is the point at which the BLOCK REPEAT function is switched ON, or alternatively, if the BLOCK REPEAT function is already switched ON, it is the point during play at which the PLAY button is depressed. If the PLAY button is depressed more than once then the effective starting point will be the last point at which the button was depressed and in the case of a reverse deck, if the end of the tape is sensed before the return point has been set then the mechanism is reversed and that point becomes the new play starting point.

The return point is the point during F-PLAY at which the REW button is depressed or the point during R-PLAY at which the FF button is depressed. However, in the case of a one-way deck, if the end of the tape is sensed before the return point has been set then the end of the tape itself will become that return point. The use of the PAUSE or its release during the course of a BLOCK REPEAT will not affect the continuation of the operation but if any other function is activated during the course of a BLOCK REPEAT then this will cause the BLOCK REPEAT function itself to be terminated at that point and then new operation to begin. When the return point is sensed for the fifth time then the BLOCK REPEAT operation is terminated and the machine stops. (see Fig. 3)

- * Where the full BLOCK REPEAT section is set to cover too short a period the return point should be moved out until sufficient length has been allowed.

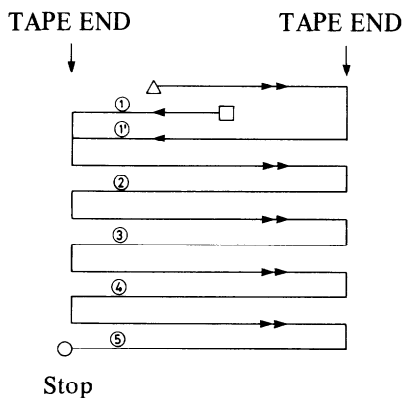

Fig. 2 Representation of FULL REPEAT operation

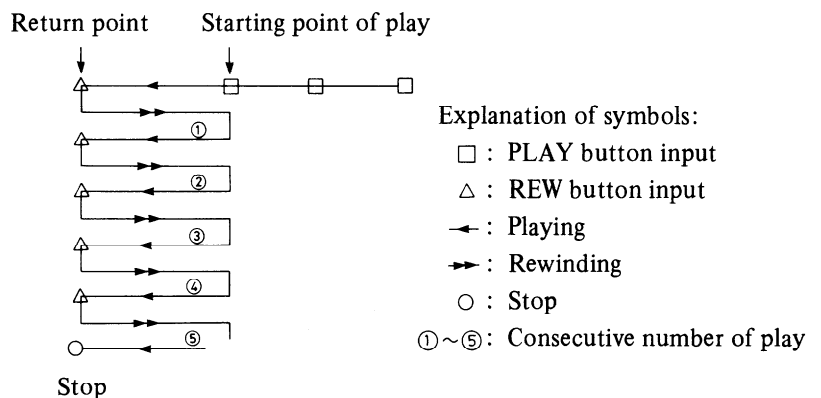

Fig. 3 Representation of BLOCK REPEAT operation
 (The play start point and return point are detected by counting the revolution pulses of the reel capstan)

AMCS is a music selection function which operates by putting the mechanism into the CUE condition and then monitoring the signals entering the SEARCH SIGNAL terminal in order to detect the start of the music and then play it for a period of about ten seconds. (Whilst in this play condition the PLAY display flashes at about 1Hz). When the ten seconds is up the machine moves to the next music selection operation.

- * The gap between pieces of music is detected by converting to normal play time and taking a nominal 5 seconds or actual 2.5 seconds or more as the nonrecorded gap.

ADJUSTMENT PROCEDURES

PRECAUTIONS

- Before adjustment, clean the following parts with an alcohol moistened swab.
 - * record/playback head
 - * erase head
 - * pinch roller
 - * capstan
- Do not use magnetized screwdriver for adjustments.
- Demagnetize record/playback head with a head demagnetizer.

TEST EQUIPMENT/TOOLS REQUIRED:

Audio oscillator
 Digital frequency counter
 Oscilloscope
 Attenuator
 AC voltmeter
 Non-magnetic screw driver
 Test tapes
 VTT-658 : 10 KHz, -15dB
 MTT-111 : 3 kHz, -10dB
 MTT-150 : Dolby level calibration
 400Hz, tone 200nWb/m

Item	Connection of instrument	Line input	Test tape	Mode	Output indicator	Adjustment point	Adjust	Remarks	
1	Tape speed	Frequency counter to LINE output terminal	MTT-111	PB	Frequency counter	Semi-fixed on the motor	3000 ± 20Hz		
2	Head azimuth	AC voltmeter and oscilloscope to LINE output terminal	VTT-658	PB	AC voltmeter	Head azimuth screw	Maximum and same phase at channels L and R	Fig.-1	
3	Playback level	AC voltmeter to terminals TP-3 and TP-4	MTT-150	PB	AC voltmeter	R107(Ch.L) R108(Ch.R)	245mV		
4	OSC Block	Frequency counter to P401 read loose coupling	METAL TAPE MX-C60	REC	Frequency counter	L-407	85kHz ± 2kHz		
5	HX-PRO	AC voltmeter to terminals TP-1 and TP-2	METAL TAPE	REC	AC voltmeter	L-405(Ch.L) L-406(Ch.R)	Maximum	R-439 R-440 Max clock wise	
6	Bias current	Fig.-2	1KHz, -20dB and 12kHz, -20dB	XL-II C-90	REC/PB	AC voltmeter	R439(Ch.L) R440(Ch.R)	Same level at REC/PB	Input VR maximum.
7	Record level	Fig-2	1kHz	XL-II C-90	REC	AC voltmeter	Attenuator or AF OSC output	350mV	
					REC/PB	AC voltmeter	R401(Ch.L) R402(Ch.R)	Same level at REC/PB	

Blank tape

NORMAL UD-1 C-90
 HIGH XL-II C-90
 METAL MX C-90

PLAY torque 30 ~ 70 g/cm
 FF.REW torque 80 ~ 180 g/cm
 Back tension. 2 ~ 7 g/cm

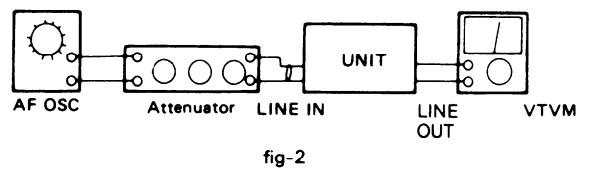
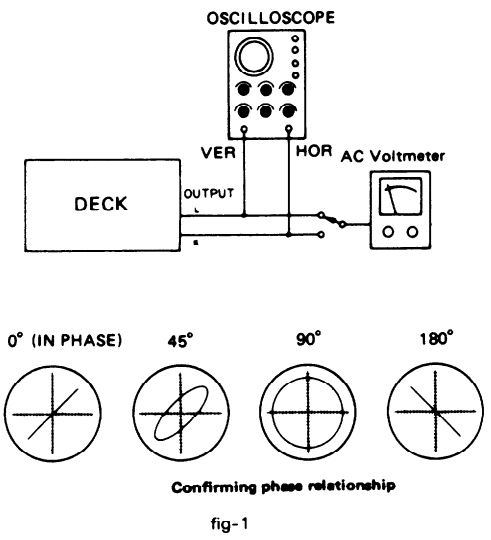
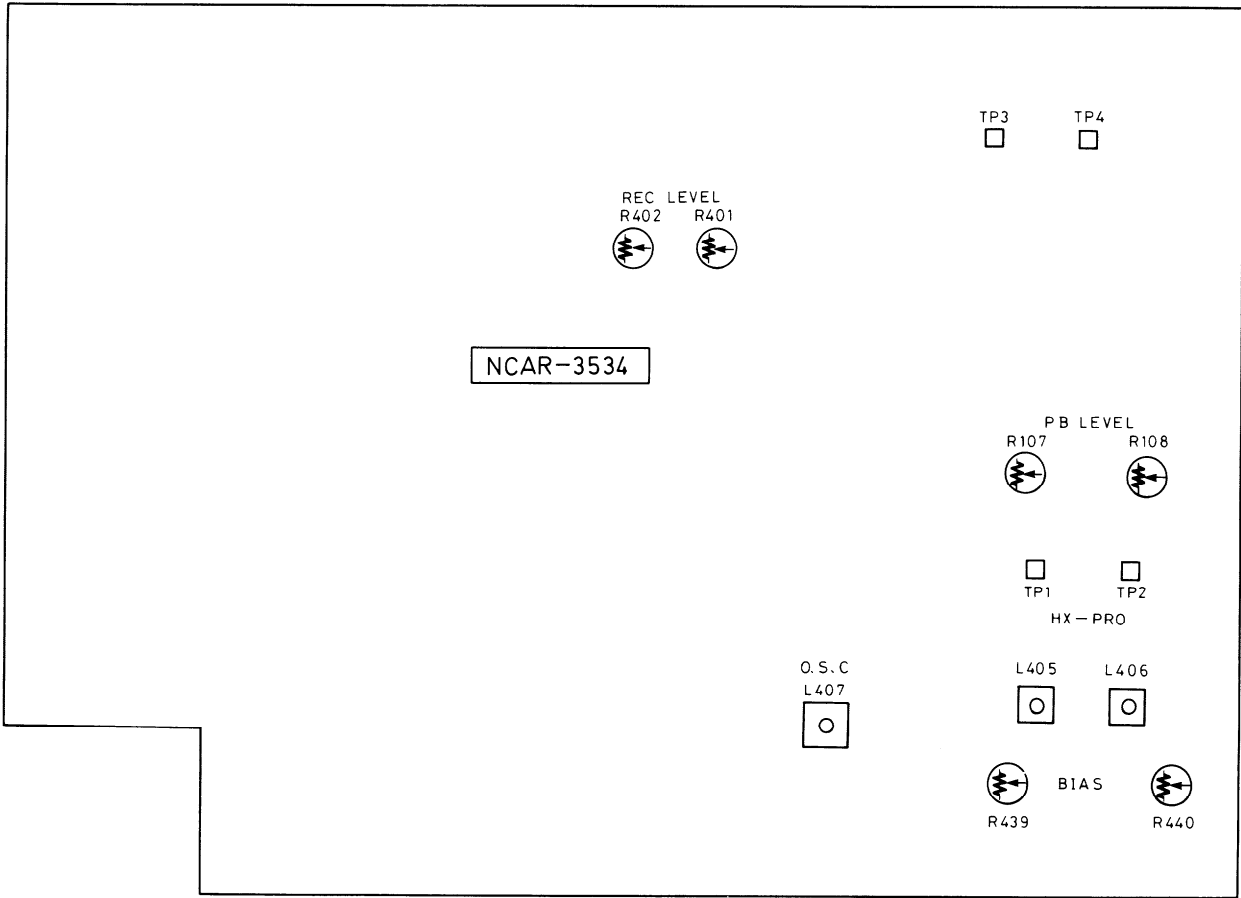

CHASSIS-EXPLODED VIEW PARTS LIST

REF.NO.	PART NO.	DESCRIPTION	REF.NO.	PART NO.	DESCRIPTION
A1	27110484	FRONT BRACKET AS	U4	1N061538-1	NAETC-3538-1
A3	27100184	CHASSIS	U5	1N061539-1	NASW-3539-1
A4	27190266	HOLDER	U6	1N061540-1	NASW-3540-1
A5	27121248	BACK PANEL (D)	U7	1N061541-1	NASW-3541-1
	27121249	BACK PANEL (G)	Z1	244124	CASSETTE DECK MACHANISM, NDM-116
	27121251	BACK PANEL (W)			
A6	27121276	BACK PANEL (QA/QB)			
A9	27300750	BUSHING (CORD)			
A13	27273069A	JOINT (POW)			
A14	28400282	DAMPER			
A17	27180315	SPRING (T2)			
A17b	28400473	FRAME AS (CASSETTE)			
A18	27180272	SPRING (CA)			
A20	27130585	BRACKET (PT)			
A21	27270142	SPACER			
A22	834430088	TAP-TIGHT SCREW 3TTS + 8B(BC)			
A23	833430080	TAP-TIGHT SCREW 3TTP + 8P(BC)			
A24	831130088	TAP-TIGHT SCREW 3TTW + 8B			
A301	830440089	TAP-TIGHT SCREW 4TTC + 8C(BC)			
A308	28184443Z	TOP COVER			
A311	28191509A	CLEAR PLATE			
A311A	28400476A	CASSETTE LID AS			
A311B	28400477	CASSETTE LID			
A312	28400468	WINDOW			
A316	27175152	LEG AS			
A501	834230108	TAP-TIGHT SCREW 3TTS + 10B(Ni)			
A801	1N061121UD	FRONT PANEL (D)			
A802	1N061121UG	FRONT PANEL (G/W)			
A803	28323241-1	KNOB (POW)			
A804	28323686A	KNOB AS (EJ)			
P901	28323684	KNOB (PUSH)			
	28323310	KNOB (TONE)			
	△ 253099C	AC CORD, AS-UC-3 (D)			
	△ 253149	AC CORD, AS-CEE (G/W)			
	△ 253118	AC CORD, AS-SAA (QA)			
	△ 253104	AC CORD, C2.5BS2 (QB)			
T901	△ 2300424A	NPT-1032D (D)			
	△ 2300425A	NPT 1032G (G)			
	△ 2300426A	NPT-1032DG (W)			
	△ 2300427	NPT-1032Q (QA/QB)			
S902	△ 25065123	NSS-1258P (W)			
U1	1N061534-1	NAAR-3534-1 (D)			
U2	1N061534-1A	NAAR-3534-1A (G/W/QA/QB)			
U3	1N061535-1	NADIS-3535-1			
	1N061537-1	NADIS-3537-1			

NOTE (D) : Only 120V model
 (G) : Only 220V model
 (W) : Only Worldwide model
 (Q) : Only 240V model
 (QB) : Only U. K. model

NOTE: THE COMPONENTS IDENTIFIED BY MARK
 ▲ ARE CRITICAL FOR RISK OF FIRE AND
 ELECTRIC SHOCK. REPLACE ONLY WITH
 PARTS NUMBER SPECIFIED.

CHASSIS-EXPLODED VIEW

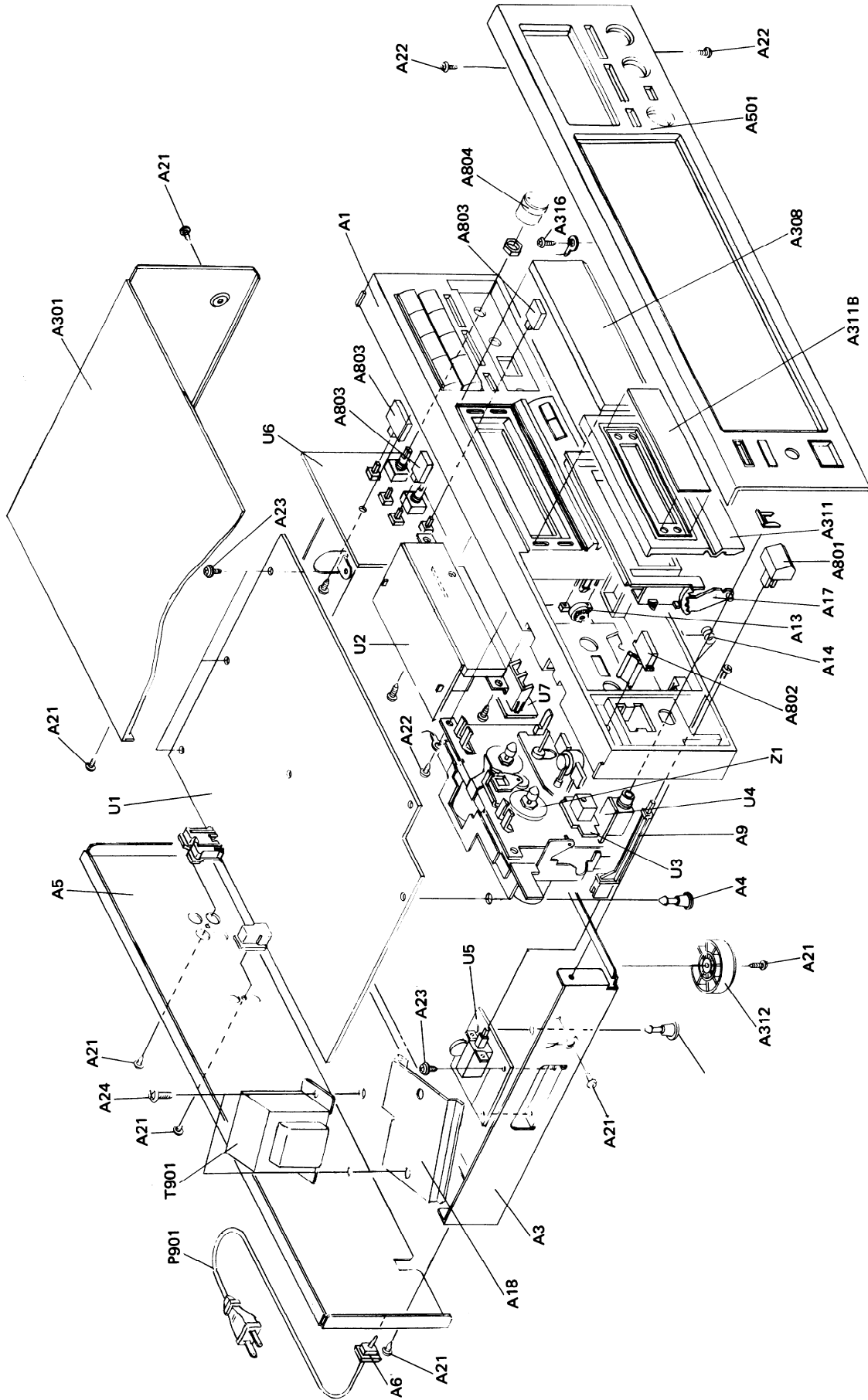

TAPE MECHANISM PARTS LIST

REF.NO.	PART NO.	DESCRIPTION
2	24611391	MECHANISM CHASSIS
2-1	24602482	IDLER AS
2-2	24601245	REEL MOTOR
2-3	24611382	BASE AS (CHASSIS)
2-4	24602483	BASE AS (REEL)
2-5	24602484	BASE AS (REEL)
2-6	24606333	SOLENOID COIL AS
2-7	82112606	PAN-HEAD SCREW 2.6P + 6F
2-8	24611177	PLASTIC WASHER 1.7 × 3.22 × .25
2-9	24606331	PLANGER
2-11	24611175	PLASTIC WASHER 2.1 × 7 × .25
2-12	24606332	CORE
3-3	24611392	HEAD BASE
3-4	24611393	SPACER (HEAD)
3-5	801291A	LOCK SCREW
3-8	24605711	SPRING
3-9	24600067	R/P HEAD
3-10	24600032	E HEAD
3-11	24606339	WIRE CONNECTOR (R/P)
3-12	24606340	WIRE CONNECTOR (E)
4	24601250	MOTOR AS
5	24606341	P.C.B. AS (CONTROL)
5-1	24606342	P.C.B.
5-13	24606343	PHOTO REFLECTOR
5-17	24606271	PUSH SWITCH
7	24607102	ARM (EJECT) L
8	24605715	SPRING
12	24607101	ARM (PLAY)
14	24602485	CAM GEAR (3R)
15	24603365	LEVER (REC)
16	24603366	LEVER (PACK) L
17	24603367	LEVER (METAL) L
18	24602489	MAIN BELT
20	24611041	PLASTIC WASHER 2.6 × 0.25
23	24610841	PLASTIC WASHER 2.6 × 4.7 × .5
25	24605714	SPRING
26	24605716	SPRING
29	24602487	FLYWHEEL AS
31	24602414B	PINCH ROLLER AS
36	24609001	PAN HEAD SCREW SW 2.6 × 5ZN
37	24609006	SCREW
39	8930151	E WASHER 1.5S
61	24611388	HOLD PLATE AS
62	833126049	TAP-TIGHT SCREW 2.6TTP + 4C
63	24611188A	WASHER (OIL SEAL)

SCHEMATIC DIAGRAM(CONTROL SECTION) 2/2

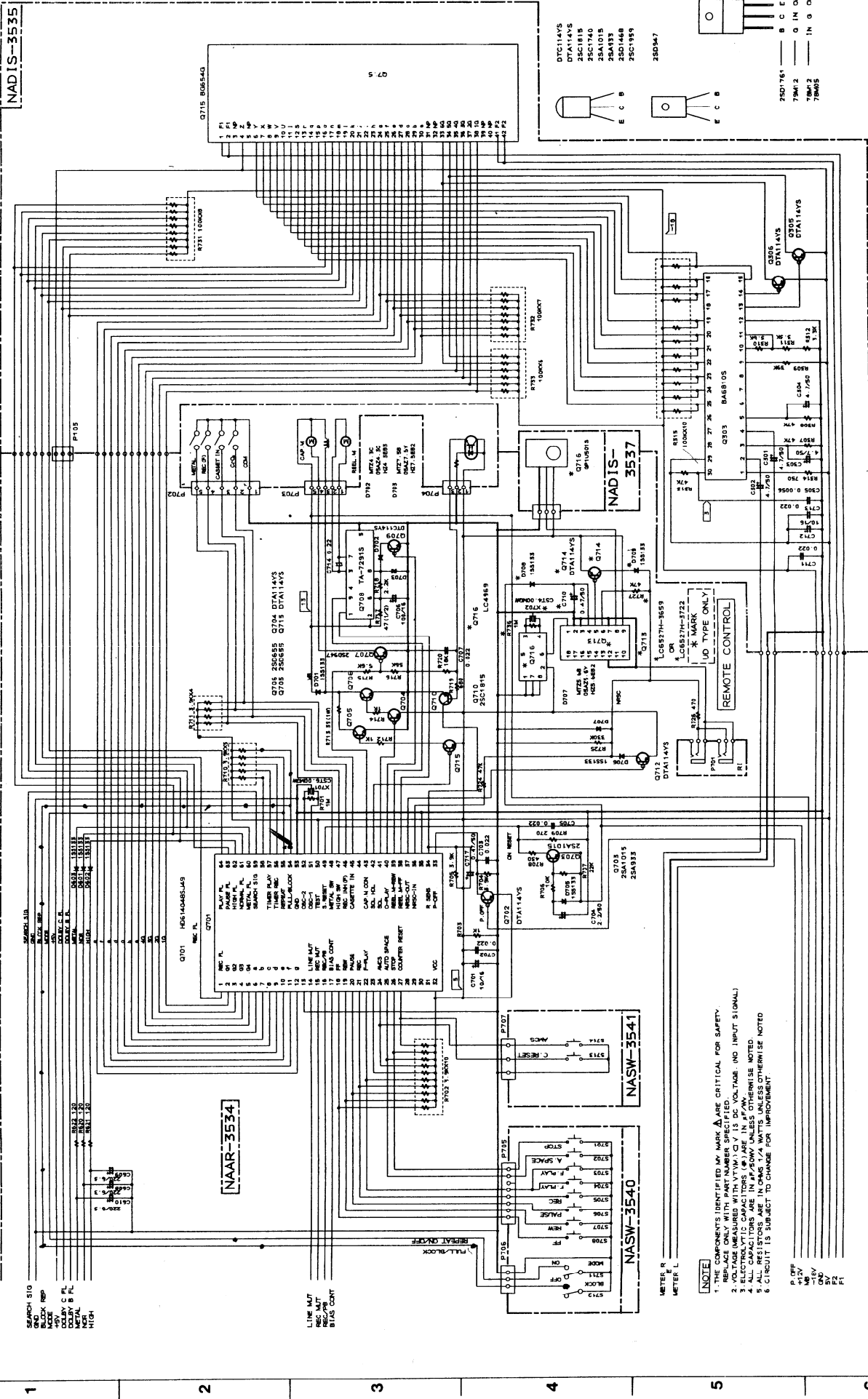

SEARCH SIG
BLOCK REP
STOP
PLAY
DOLBY B P L
METAL
HIGH

LINE MUT
REC-PT
BIAS CONT

- NOTE
1. THE COMPONENTS IDENTIFIED BY MARK Δ ARE CRITICAL FOR SAFETY.
 2. VOLTAGE UNLESS OTHERWISE SPECIFIED IS AC R.M.S. VALUE (NO INPUT SIGNAL).
 3. ELECTROLYTIC CAPACITORS (Δ) ARE IN μ F AND IN μ F/50V UNLESS OTHERWISE NOTED.
 4. ALL CAPACITORS ARE IN μ F/50V UNLESS OTHERWISE NOTED.
 5. RESISTORS ARE IN OHMS UNLESS OTHERWISE NOTED.
 6. CIRCUIT IS SUBJECT TO CHANGE FOR IMPROVEMENT.

P OFF
+2V
-2V
5V
P2
P1

METER R
METER L

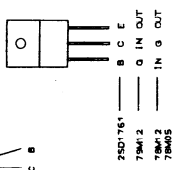
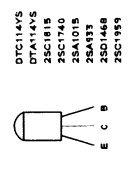

SCHEMATIC DIAGRAM (AUDIO SECTION) 1/2

A B C D E F G H

TA-2200 TA-2200

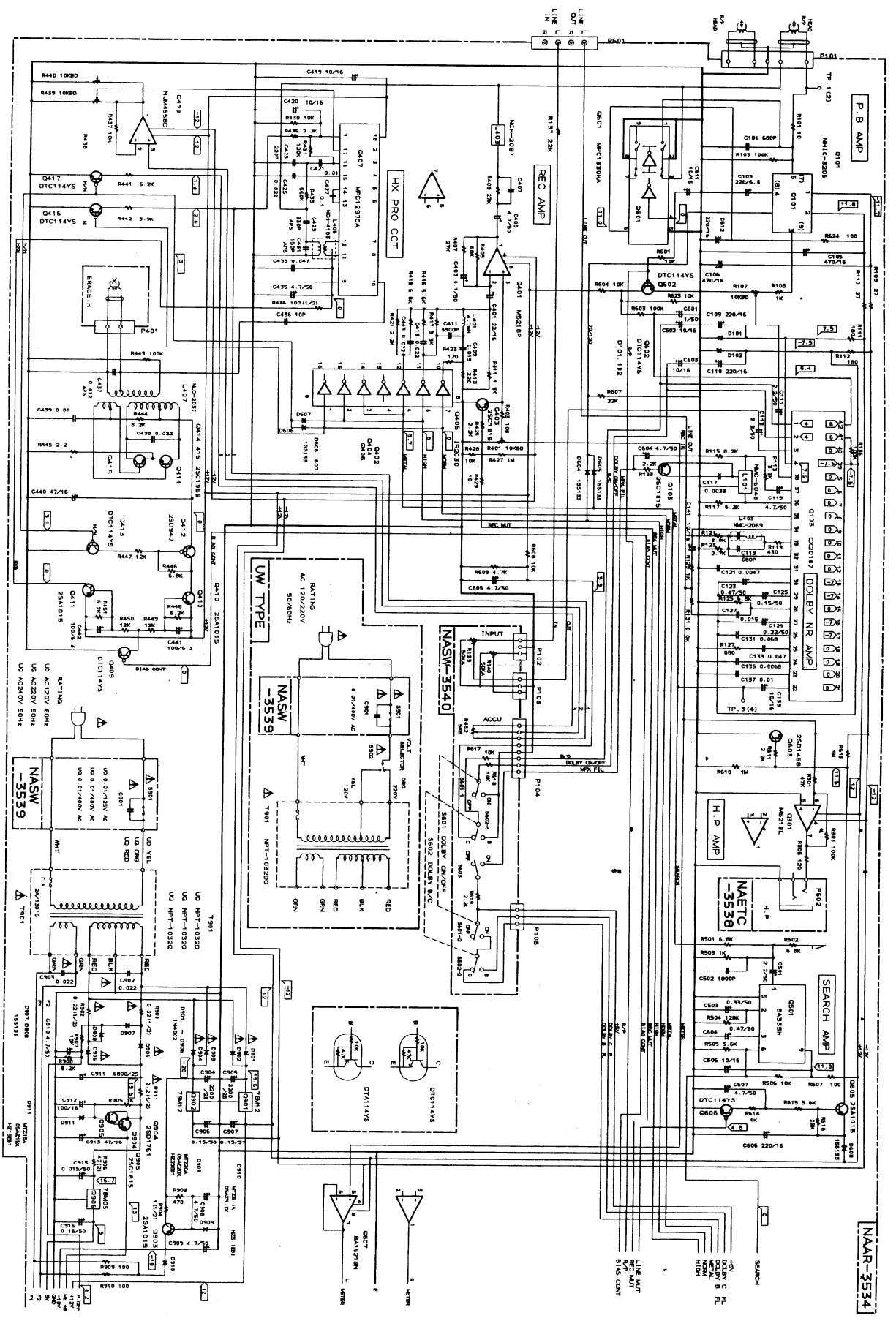

A B C D E F G H

TAPE MECHANISM-EXPLODED VIEW

