

# ONKYO SERVICE MANUAL

## STEREO CASSETTE TAPE DECK MODEL TA-2600

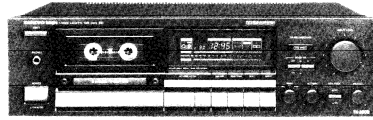

Black model

UD,UD <sup>Ⓝ</sup>	120V AC, 60Hz
UG	220V AC, 50Hz
UW	120 or 220V AC, 50/60Hz
UOA, UOB	240V AC, 50Hz

### SAFETY-RELATED COMPONENT WARNING!!

COMPONENTS IDENTIFIED BY MARK  $\triangle$  ON THE SCHEMATIC DIAGRAM AND IN THE PARTS LIST ARE CRITICAL FOR RISK OF FIRE AND ELECTRIC SHOCK. REPLACE THESE COMPONENTS WITH ONKYO PARTS WHOSE PARTS NUMBERS APPEAR AS SHOWN IN THIS MANUAL.

MAKE LEAKAGE-CURRENT OR RESISTANCE MEASUREMENTS TO DETERMINE THAT EXPOSED PARTS ARE ACCEPTABLY INSULATED FROM THE SUPPLY CIRCUIT BEFORE RETURNING THE APPLIANCE TO THE CUSTOMER.

## SPECIFICATIONS

Track Format:	4-tracks, 2-channels
Erasing System:	AC erase
Tape Speed:	4.8 cm/sec. (1-7/8 i.p.s.)
Wow and Flutter:	0.045% (WRMS)
Frequency Response:	20–17,000Hz (Normal) (30–16,000Hz $\pm$ 3dB) 20–18,000Hz (High) (30–17,000Hz $\pm$ 3dB) 20–19,000Hz (Metal) (30–18,000Hz $\pm$ 3dB)
S/N Ratio:	60dB (metal tape, Dolby NR off) A noise reduction of 10dB above 5kHz and 5dB at 1kHz is possible with Dolby B NR. A noise reduction of 20dB at 5kHz is possible with Dolby C NR.
Input Jacks:	Line IN: 2 Input sensitivity: 60mV Input impedance: 50kohms
Outputs:	Line OUT: 2 Standard output level: 500mV (0dB) Optimum load impedance: over 50 kohms Headphone jack: 1 Optimum load impedance: 8 to 200 ohms
Motors:	DC servo motor: 1 DC motor: 2
Heads:	REC/PB: Special Hard Permalloy x 1; Erase head: Ferrite x 1
Power Supply Rating:	U.K. and Australian models: AC 240V, 50Hz U.S.A. and Canadian models: AC 120V, 60Hz Worldwide models: AC 120V and 220V switchable, 50 / 60Hz
Power Consumption:	19 watts
Dimensions:	435(W) x 132(H) x 366(D)mm (17-1/8" x 5-3/16" x 14-3/8")
Weight:	5.8 kg. (12.8 lbs.)

Specifications and external appearance are subject to change without notice because of product improvements.

**ONKYO**<sup>®</sup>  
**AUDIO COMPONENTS**

## SERVICE PROCEDURES

### 1. Replacement of power supply cord

There are two power supply cord outlets on the strainrelief. Insert them in prescribed direction to ensure safety. AS-UC-3 (UD<120V> model) should be inserted lengthwise and other types of cords should be inserted horizontally.

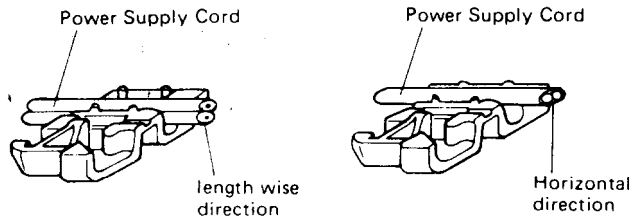

### 2. Insulating resistance measurement

Connect the insulating-resistance tester between the plug of power supply cord and chassis.

Specifications: 500V more than 10MΩ

## HX PRO CIRCUIT OPERATION EXPLANATION

### 1. Regarding recording frequency characteristic and bias

Ordinarily, if the recording bias current is increased, REC/PB frequency response level in the high frequency region (about 10KHz and above) drops, and if the bias is decreased, the response rises.

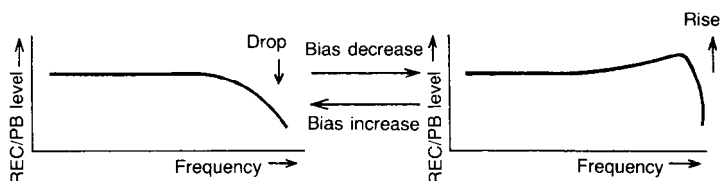

### 2. Regarding the basic operation of HX PRO (Refer to Fig. 1)

The HX PRO uses the  $\mu$  PC1297CA IC. The operation is in accordance with the following.

- 1) At (a), the recording bias is added onto the audio signal, and the recording signal is detected. This is the same as the recording head recording the signal on the tape.
- 2) The signal of 1) preserves the frequency response with the integrated circuit of (b).

$$\text{Frequency} = \frac{R450 + R448}{2\pi \times C426 \times R450 \times R448} \quad (2.1)$$

By means of the frequency of Fig. 1, the frequency which is effective from the beginning is determined. In the ordinary situation, this is half the audio band (10KHz), (10KHz ~ 7.5KHz).

- 3) At (c), in order to use the affected waveform after-ward, absolute detection is carried out.

- 4) At (d), the waveform peak value is detected. The output becomes the peak DC voltage.

- 5) At (e), the standard voltage and the voltage of (4) are compared.

- 6) With the output of (e), the frequency generation level is controlled (voltage controlled amplifier). That is, the bias size is varied.

- 7) Summing up 1) ~ 6):

At (a), the time constant (frequency) that is detected in the recording signal is preserved, and above a certain frequency and above a certain level, the VCA controls the bias current by causing its reduction. When this is done, in the manner shown in the explanation of Item 1 above, the frequency high region is raised. With this control, the audio signal is instantaneously dealt with.

### 3. Regarding the operating conditions of the HX PRO

- 1) With equation (2. 1) noted above, the effect begins at the frequency thus determined.

- 2) Above a certain level the effect begins.

(Substantially 0 dB: In the vicinity of 500mV line out)  
The audio signal component level is dependent upon the waveform after point (c).

# HX PRO BLOCK DIAGRAM

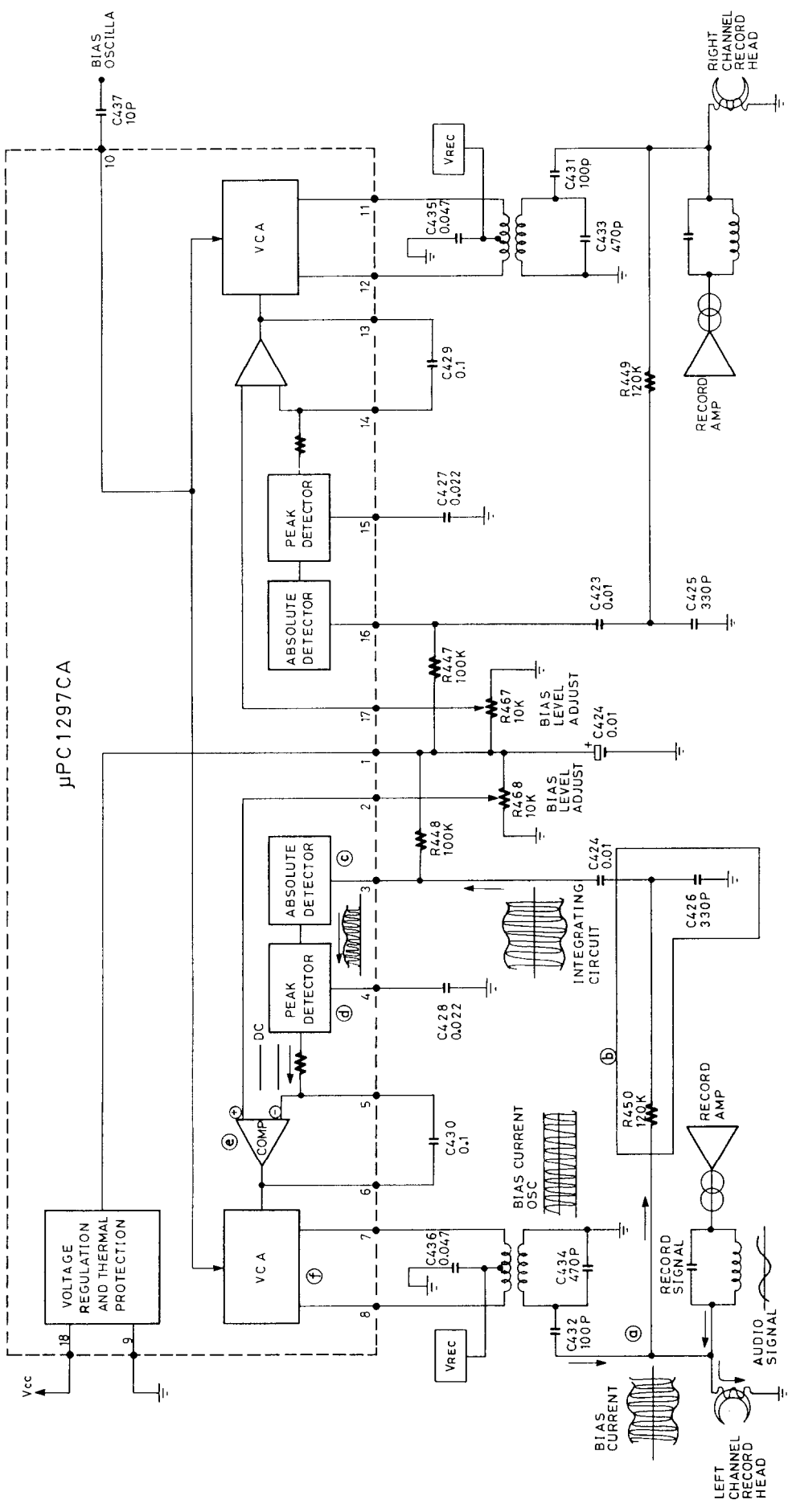

Fig. 1

$$f = \frac{R450 + R448}{2\pi \times C426 \times R450 \times R448}$$

① CUT OFF



## HD614128SA41 (COUNTER)

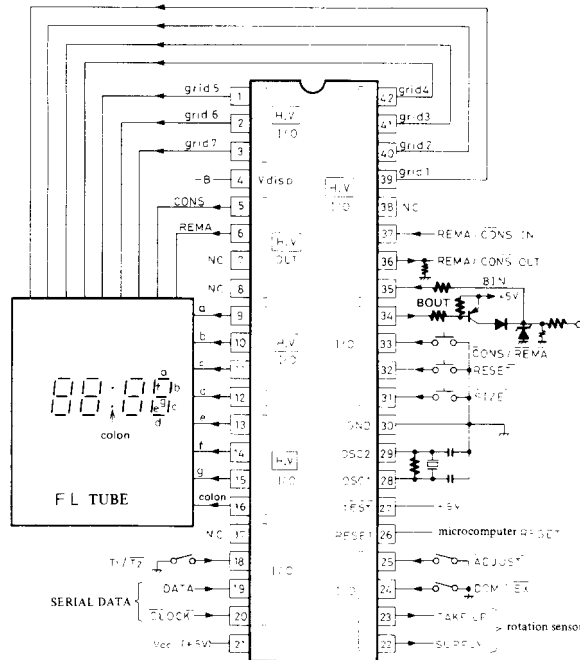

## Terminal Name and Function

Pin No.	Name	Function
1 ~ 3	Grid 5 ~ 7	FL tube grid (DIGIT) drive use output
4	V <sub>disp</sub>	Input (FL tube use) for minus bias voltage to pin Nos. 1 ~ 3, 5, 6, 9 ~ 16, 39 ~ 42
5	CONS	FL tube <b>CONS</b> display use output (time lapse)
6	REMA	FL tube <b>REMA</b> display use output (time remaining)
9 ~ 15	a ~ g	FL tube segment drive use output
16	Colon	FL tube ":" drive use output
18	T <sub>1</sub> /T <sub>2</sub>	Microcomputer T <sub>1</sub> /T <sub>2</sub> function selection input (With T <sub>2</sub> , system I/O receiving)
19	DATA	Deck mechanism status input (8 bit serial data) from mechanism control micro-computer
20	CLOCK	Clock input for reading above DATA (DATA taken on pulse wave dropping)
21	V <sub>cc</sub>	Microcomputer power source (+5V)
22	SUPPLY	Cassette mechanism tape feed side turning pulse input
23	TAKE UP	Cassette mechanism tape windup side turning (pulse input)
24	DOM/EX	Domestic/export setting use selector input (Tape size type selector use) Domestic: With power ON C46 → C54 → C60 → C80 → C90 → C120
25	ADJUST	Remaining time calculation buffer compensating value input (normally open, compensating ground)
26	RESET	Microcomputer system reset
27	TEST	Microcomputer internal test use port, normally connected to V <sub>cc</sub>
28, 29	OSC1, OSC2	Microcomputer clock oscillator terminal
30	GND	Microcomputer power source (GND)
31	SIZE	Tape size selector input
32	RESET	Lapsed time reset input (When <b>CONS</b> displays, digits are □ : □ □)
33	CONS/REMA	Lapsed time ← → remaining time selector input (toggle display)
34	BOUT	System bus output
35	BIN	System bus input
36	REMA/CONS OUT	Remaining time display/lapsed time display status output (when T <sub>2</sub> )
37	REMA/CONS IN	Remaining time display/lapsed time display status input (when T <sub>2</sub> )
39 ~ 42	Grid 1 ~ 4	FL tube grid (DIGIT) drive use output

# ADJUSTMENT PROCEDURES

## PRECAUTIONS

- Before adjustment, clean the following parts with an alcohol moistened swab.
  - \* record/playback head
  - \* pinch roller
  - \* erase head
  - \* capstan
- Do not use magnetized screwdriver for adjustments.
- Demagnetize record/playback head with a head demagnetizer.

## TEST EQUIPMENT/TOOLS REQUIRED:

Audio oscillator  
 Digital frequency counter  
 Oscilloscope  
 Attenuator  
 AC voltmeter  
 Non-magnetic screw driver  
 Test tapes

VTT-658 : 10 KHz, -15dB  
 MTT-111 : 3 kHz, -10dB  
 MTT-150 : Dolby level calibration  
 400Hz, tone 200nWb/m

Item	Connection of instrument	Line input	Test tape	Mode	Output indicator	Adjustment point	Adjust	Remarks
1	Tape Speed Frequency counter to LINE output terminal		MTT-111	PB	Frequency counter	Semi-fixed on the motor	3,005 to 3,010Hz	
2	Head azimuth AC voltmeter and oscilloscope to LINE output terminal		VTT-658	PB	AC voltmeter	Head azimuth screw	Maximum and same phase at channels L and R	Fig-1
3	Playback level AC voltmeter to terminals TP-1 and TP-2		MTT-150	PB	AC voltmeter	R-107 (Ch.L) R-108 (Ch.R)	245mV	
4	Meter		MTT-150	PB	Level meter	R-501 (Ch.L) R-502 (Ch.R)	0dB	NADIS-3339
5	Bias trap AC voltmeter to terminals TP-1 and TP-2		METAL TAPE	REC	AC voltmeter	L-101 (Ch.L) L-102 (Ch.R)	Minimum	
6	HX-PRO AC voltmeter to terminals TP-3 and TP-4		METAL TAPE	REC	AC voltmeter	L-409 (Ch.L) L-410 (Ch.R)	Maximum	R-467 R-468 counter clock wise
7	Bias current AC voltmeter to LINE output terminal	1kHz, -20dB and 12kHz, -20dB	NEW XL-II90	REC/PB	AC voltmeter	R-467 (Ch.L) R-468 (Ch.R)	Same level at REC/PB	Input VR maximum
8	Record level Fig-2	1kHz		REC	AC voltmeter	Attenuator or AF OSC output	350mV	Input VR maximum
				REC/PB	AC voltmeter	R-413 (Ch.L) R-414 (Ch.R)	Same level at REC/PB	

### Blank tape

NORMAL . . . . . UD-1 C-90  
 HIGH . . . . . XL-II C-90  
 METAL . . . . . MX C-90

PLAY torque . . . . . 30 - 60g/cm  
 FF.REW torque . . . . . 70 - 140g/cm  
 Back tension . . . . . 2 - 5g/cm

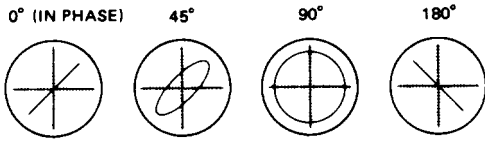
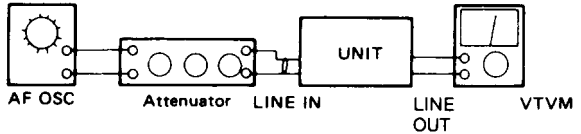
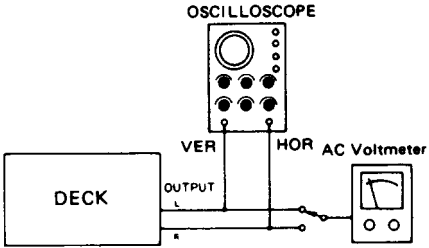
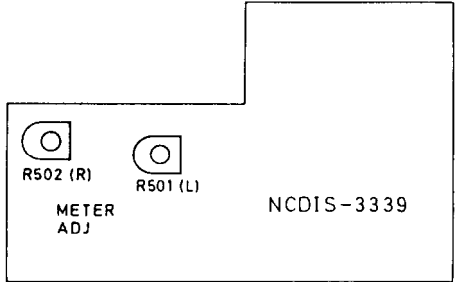
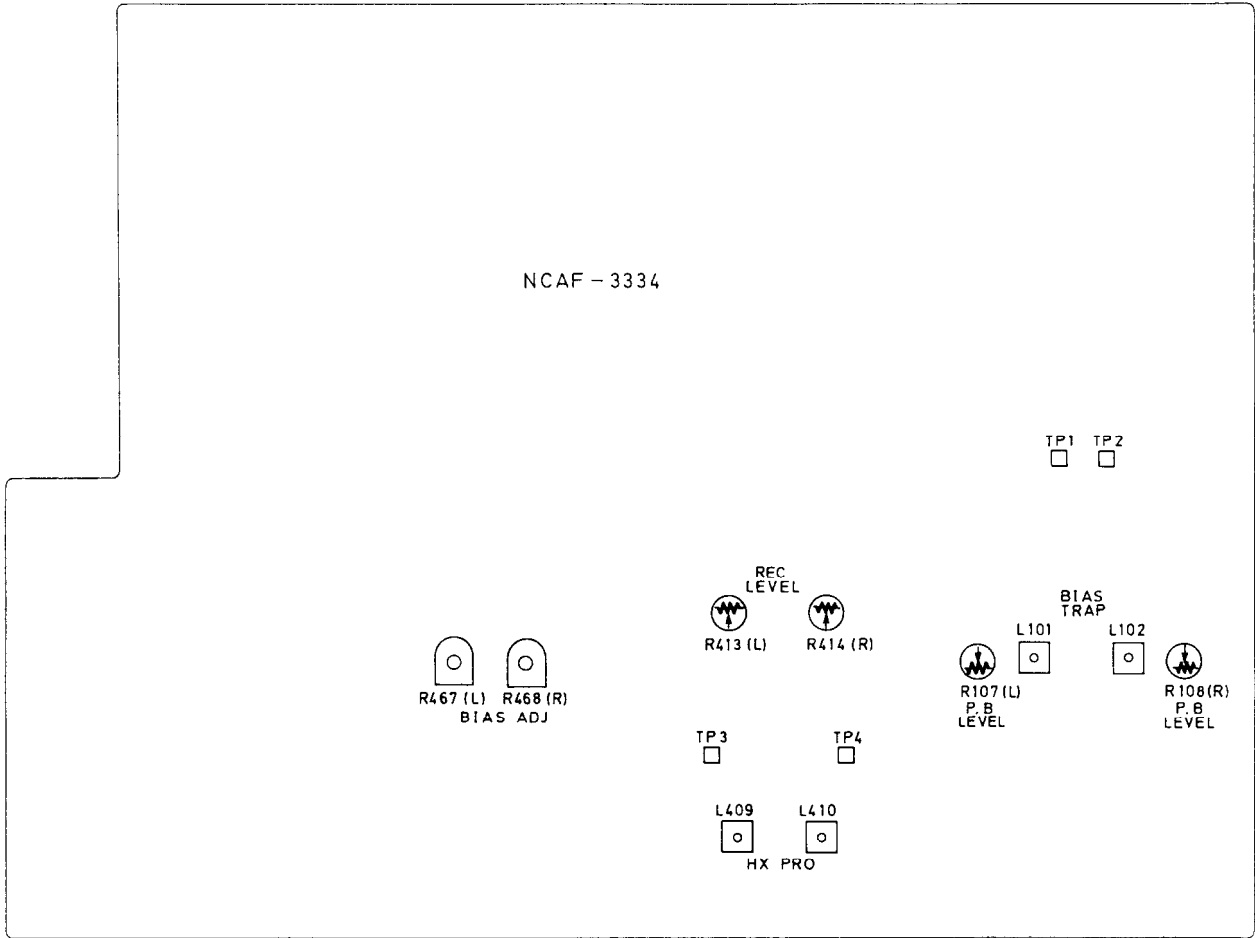

Confirming phase relationship  
fig-1

fig-2





## CHASSIS-EXPLODED VIEW PARTS LIST

REF.NO.	PART NO.	DESCRIPTION	REF.NO.	PART NO.	DESCRIPTION
A1	27110420A	FRONT BRACKET AS		253112A	AC CORD AS-UC-4 (D)
A4	27141273	BRACKET (PC)	▲ P901	253149	AC CORD AS-CEE (G/W)
A5	28133200	BACK PLATE		253104	AC CORD C2.5BS2 (O)
A6	27130536A	BRACKET (PT)	▲ S902	25065123	NSS-1258P (W)
A7	27130537A	BRACKET (VOL)	▲ T901	2300335	NPT-1003D (D)
A8	27273069A	JOINT (POW)		2300336	NPT-1003G (G)
A9	27190524	HOLDER		2300337	NPT-1003DG (W)
A11	27121117	BACK PANEL (D)		2300359	NPT-1003Q (O)
	27121118	BACK PANEL (G)	U1	IN040534-1	NAAF-3334-1 (D/W)
	27121119	BACK PANEL (W)		IN040534-1A	NAAF-3334-1A (G/Q)
	27121180	BACK PANEL (O)		IN040536-1	NADIS-3336-1
A12	27100164B	CHASSIS	U3	IN040537-1	NASW-3337-1
A14	834430088	TAP-TIGHT SCREW 3TTS+8BBC	U4	IN040538-1	NAETC-3338-1
A15	831130088	TAP-TIGHT SCREW 3TTW+8B	U5	IN040539-1	NADIS-3339-1
A16	830440109	TAP-TIGHT SCREW 4TTC+10CB	U6	IN040540-1	NAAF-3340-1
A18	838426088	TAP-TIGHT SCREW 2.6TTB+8B	U7	IN040541-1	NAAF-3341-1
A19	27300750	BUSHING (CORD)	U8	IN040542-1	NASW-3342-1
A20	28140877	CUSHION	U9	IN040543-1	NASW-3343-1
A21	28140881	CUSHION	U10	IN040543-1	NASW-3343-1
A22	27270214A	SPACER	Z1	244114	NDM-106,CASSETTE DECK MECHANISM
A301	28184397	TOP COVER			
A302	838440089	TAP-TIGHT SCREW 4TTB+8CBC			
A304	28140408	CUSHION			
A307	28125194-1	END CAP (L)			
A308	28125195-1	END CAP (R)			
A309	27267553A	GUIDE (VOL)			
A310	28194297	COSMETIC BAR			
A311	27267481B	GUIDE (POW)			
A312	28198670	FACET (POW)			
A314	28191469	CLEAR PLATE			
A316	28191472	CLEAR PLATE (RE)			
A318	27301123A	CASSETTE LID			
A319	27301122	CASSETTE LID (AL)			
A320	28400413	WINDOW			
A321	28135153	BADGE			
A322	833430080	TAP-TIGHT SCREW 3TTP+8PBC			
A323	834230108	TAP-TIGHT SCREW 3TTS+10BNI			
A330	27175153	LEG			
A501	IN041121	FRONT PANEL			
A801	28323388A	KNOB (PUSH)			
A803	28323389	KNOB (BAL)			
A806	28323287	KNOB (EJECT)			
A807	27260279	SHAFT (EJ)			
A808	28323395	KNOB (LEV)			
A810	28323175	KNOB (POW)			

NOTE:  
(D): Only 120V model  
(G): Only 220V model  
(W): Only Worldwide model  
(O): Only 240V model

NOTE: THE COMPONENTS IDENTIFIED BY MARK  
▲ ARE CRITICAL FOR RISK OF FIRE AND  
ELECTRIC SHOCK. REPLACE ONLY WITH  
PARTS NUMBER SPECIFIED.

**BG-555G (DISPLAY TUBE)**

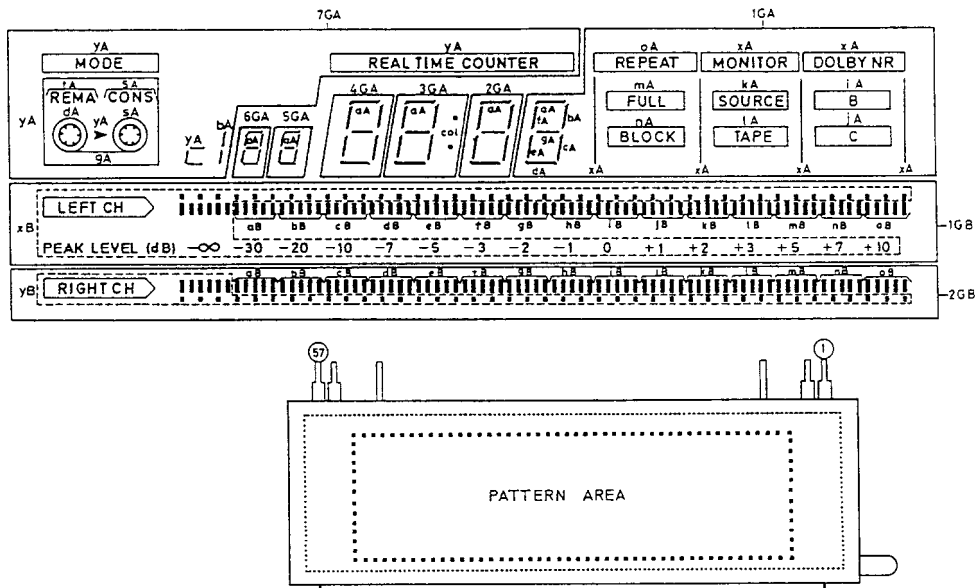

**PIN CONNECTION**

PIN NO.	40	39	38	37	36	35	34	33	32	31	30	29	28	27	26	25	24	23	22	21	20	19	18	17	16	15	14	13	12	11	10	9	8	7	6	5	4	3	2	1
CONNECTION	n B	o B	y B	x B	2G B	1G B	N P	N P	t A	s A	y A	7G A	6G A	5G A	4G A	3G A	2G A	h A	g A	f A	e A	d A	c A	b A	a A	1G A	x A	r A	q A	p A	o A	n A	m A	l A	k A	j A	i A	N P	F J	F I
PIN NO.	57	56	55	54	53	52	51	50	49	48	47	46	45	44	43	42	41																							
CONNECTION	F 2	F 2	N P	N P	a B	b B	c B	d B	e B	f B	g B	h B	i B	j B	k B	l B	m B																							

**PACKING VIEW**

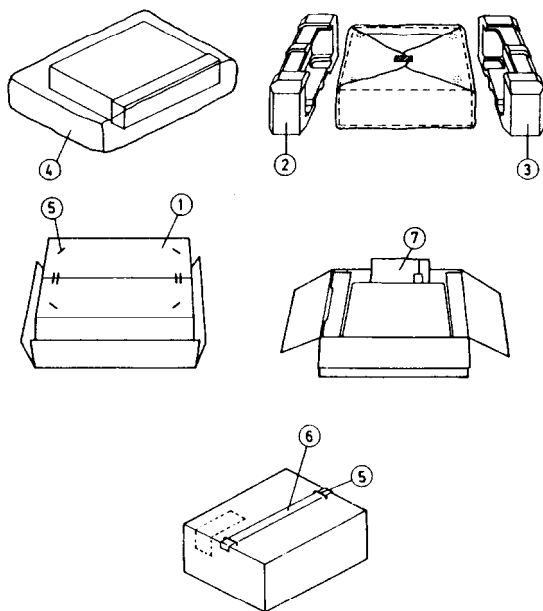

**NOTE:**

- N : Only USA model
- W : Only 120/220V model
- I : Only Italy model
- QB : Only U.K. model

**D Model**

REF NO.	PART NO.	DESCRIPTION
1	29051713	Master carton box
2	29091264A	Pad (L)
3	29091265A	Pad (R)
4	29100105	620 × 550 Poly bag
5	282301	Sealing hook
6	260012	Damplon tape
7	Accessory bag ass'y	
	29341280A	Instruction manual
	2010098A	Connection cable
	29365019	Waranty card (N)
	29358002F	Service station list (N)
	29100006A	350 × 250 Poly bag

**G/W Model.**

REF NO.	PART NO.	DESCRIPTION
1	29051713	Master carton box
2	29091264A	Pad (L)
3	29091265A	Pad (R)
4	29100105	620 × 550 Poly bag
5	282301	Sealing hook
6	260012	Damplon tape
7	Accessory bag ass'y	
	29341279	Instruction manual
	29341281	Instruction manual (I)
	2010098A	Connection cable
	29100006A	350 × 250 Poly bag
	29365022	Waranty card (QB)
	25055018	Conversion Plug (CV-K-1)(W)

# PC BOARD PARTS LIST

## NAAF-3334-1

CIRCUIT NO.	PART NO.	DESCRIPTION	CIRCUIT NO.	PART NO.	DESCRIPTION
<b>ICs</b>					
Q101	222999	CX-20187	Q716	2211255 or 2210746	2SC1815-GR or 2SC945-AP
Q151	222502	NJM-4558DX	Q717	221282	DTC144ES
Q160	222078	NHIC-3205	Q903	2211455 or 2212495	2SA1015-GR or JA101Q
Q203	222999	CX-20187	Q904	2201924 or 2201385	2SD1761-E or 2SD330-E
Q215	222502	NJM-4558DX	Q905	2211255 or 2210746	2SC1815-GR or 2SC945-AP
Q301	22240111 or 222808	BA15218 or M5218P	<b>Diodes</b>		
Q303	222940	BA335H	D101, D102	224450822, 224150822 or 224650822	MTZ8.2B, 05AZ8.2Y or HZ8.2EB2
Q401	222502	NJM-4558DX	D151-D154	223163	ISS133
Q403	22240111 or 222808	BA15218 or M5218P	D201, D202	224450822, 224150822 or 224650822	MTZ8.2B, 05AZ8.2Y or HZ8.2EB2
Q407	222959	$\mu$ PC1297CA	D205, D206	223163	ISS133 (G)
Q415	222921 or 222465	BA4558 or NJM-4558D	D207-D211	223163	ISS133
Q701	22240169	HD614042SH57	D401	223163	ISS133
Q706, Q709	222953	M-54544AL	D406-D411	223163	ISS133
Q901, Q902	222780125MIT	78M12	D702	224451003, 224151003 or 224651003	MTZ10C, 05AZ10Z or HZ10EB3
Q906	222780055MIT	78M05	D703	224450562, 224150562 or 224650562	MTZ5.6B, 05AZ5.6Y or HZ-5.6E-B2
<b>Transistors</b>			D704, D705	223163	ISS133
Q103	2211255 or 2210746	2SC1815-GR or 2SC945-AP	D901-D906	22380006 or 223894	1N4003 or 1N4002F
Q104	2211455 or 2212495	2SA1015-GR or JA101Q	D907	224452001, 224152001 or 224652001	MTZ20A, 05AZ20X or HZ20EB1
Q153, Q154	2211406 or 2211896	2SC2240-BL or (G) 2SC1815LL	D908	224450511, 224150511 or 224650511	MTZ5.1A, 05AZ5.1X or HZ5.1EB1
Q155, Q156	2211455 or 2212495	2SA1015-GR or (G) JA101Q	D909	22380006 or 223894	1N4003 or 1N4002F
Q205-Q209	2211255 or 2210746	2SC1815-GR or 2SC945-AP	D910	224451501, 224151501 or 224651501	MTZ15C, 05AZ15X or HZ15EB1
Q210	2211455 or 2212495	2SA1015-GR or JA101Q	D911, D912	223163	ISS133
Q211-Q214	2212304 or 2211945	2SK381-D or 2SK246-GR	<b>Coils</b>		
Q219, Q220	2211255 or 2210746	2SC1815-GR or 2SC945-AP	L101, L102	231147	NCH-4199
Q221, Q222	2211706	2SD655-F	L103, L104	233382	NMC-2069
Q223, Q224	2212304 or 2211945	2SK381-D or (G) 2SK246-GR	L201, L202	233328	NMC-6051
Q225, Q226	221281	DTC114YS	L203, L204	233382	NMC-2069
Q227	2211455 or 2212495	2SA1015-GR or JA101Q	L407, L408	231101	NCH-2148
Q405, Q406	2212794 or 2212795	2SD1468-R or 2SD1468-S	L409, L410	231100	NCH-4147
Q422	2211455 or 2212495	2SA1015-GR or JA101Q	L411, L412	231077	NCH-2125
Q423, Q424	221282	DTC144ES	<b>OSC Block</b>		
Q425	2201540	2SD947	Z401	24606198	NOB-029
Q426-Q428	2211455 or 2212495	2SA1015-GR or JA101Q	<b>Ceramic OSC</b>		
Q429, Q430	221282	DTC144ES	X701	3010099 or 3010128	CSA-4.00MG or PRS-4.00RM11
Q703	2213090	DTA114YS	<b>Capacitors</b>		
Q704	221281	DTC114YS	C103, C104	354722219	220 $\mu$ F6.3V, ELECT.
Q705	2201385	2SD330-E	C105, C106	354741009	10 $\mu$ F16V, ELECT.
Q707	221281	DTC114YS	C107, C108	354741009	10 $\mu$ F16V, ELECT.
Q708	2201540	2SD947	C115, C116	354744719	470 $\mu$ F16V, ELECT.
Q710	2201540	2SD947	C139, C140	354741009	10 $\mu$ F16V, ELECT.
Q711	2211255 or 2210746	2SC1815-GR or 2SC945-AP	C141, C142	354741019	100 $\mu$ F16V, ELECT.
Q712	2213090	DTA114YS	C143, C144	354742219	220 $\mu$ F16V, ELECT.
Q713	2211455 or 2212495	2SA1015-GR or JA101Q	C147	354742209	22 $\mu$ F16V, ELECT.
Q714	2211255 or 2210746	2SC1815-GR or 2SC945-AP			
Q715	221282	DTC144ES			



A B C D E F G H

TAPE MECHANISM-EXPLODED VIEW

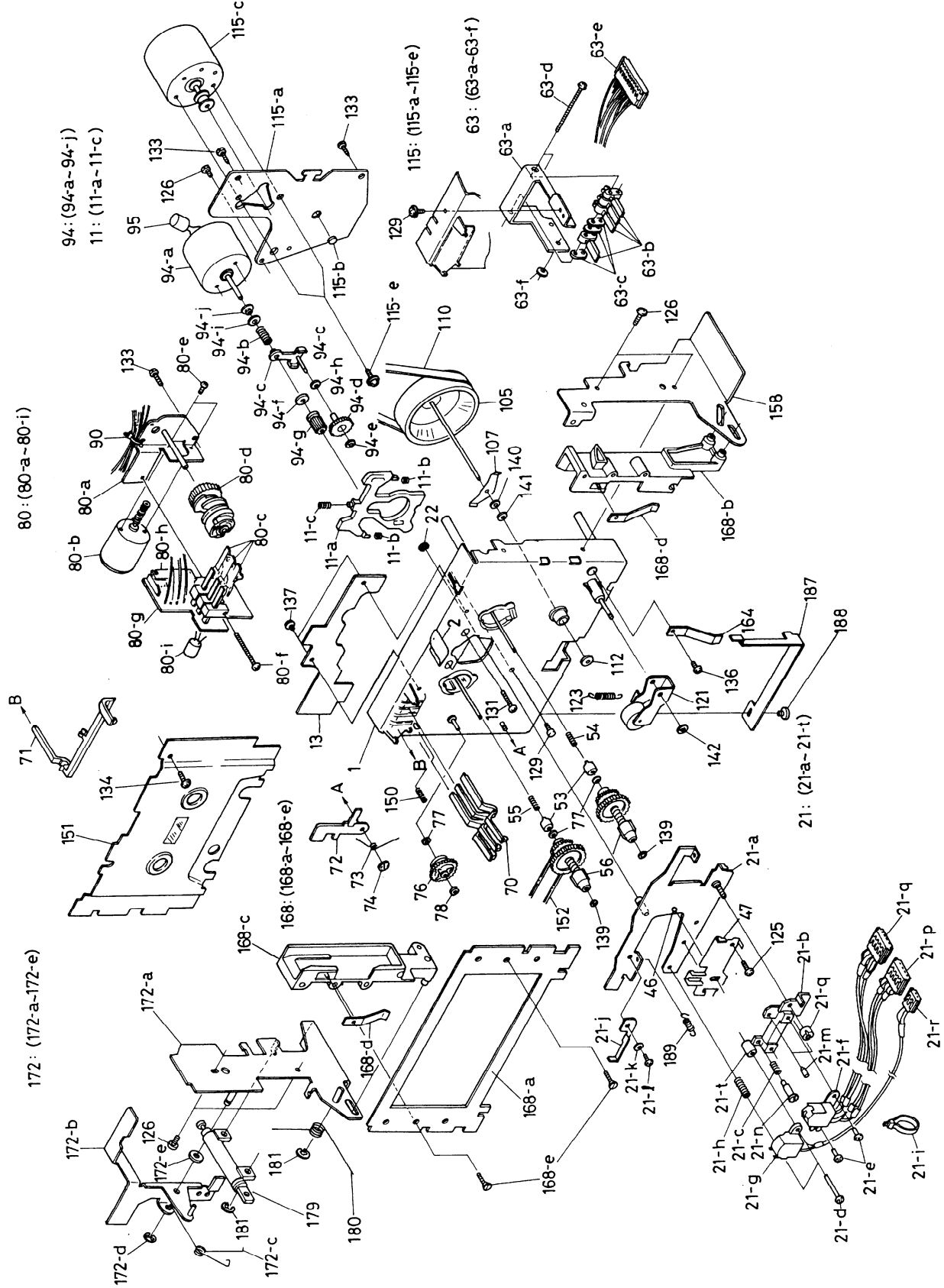



# SCHEMATIC DIAGRAM (2/2)

### NOTES

- THE COMPONENTS IDENTIFIED BY MARK  $\Delta$  ARE CRITICAL FOR SAFETY.
- REPLACE ONLY WITH PART NUMBER SPECIFIED.
- ALL RESISTORS ARE IN OHMS UNLESS OTHERWISE NOTED.
- CAPACITORS ARE IN MICROFARADS UNLESS OTHERWISE NOTED.
- ELECTROLYTIC CAPACITORS (E.C.) ARE IN  $\mu$ F.
- VOLTAGE MEASURED WITH V.T.V.M.  $\square$  V IS DC VOLTAGE (NO INPUT SIGNAL).

