

ONKYO SERVICE MANUAL

STEREO CASSETTE TAPE DECK MODEL TA-2700

UDN, UDC, UD	120V AC, 60Hz
UG	220V AC, 50Hz
UW	120 or 220V AC, 50/60Hz
UQA, UQB	240V AC, 50Hz

SAFETY-RELATED COMPONENT WARNING!!
COMPONENTS IDENTIFIED BY MARK Δ ON THE SCHEMATIC DIAGRAM AND IN THE PARTS LIST ARE CRITICAL FOR RISK OF FIRE AND ELECTRIC SHOCK. REPLACE THESE COMPONENTS WITH ONKYO PARTS WHOSE PARTS NUMBERS APPEAR AS SHOWN IN THIS MANUAL.

MAKE LEAKAGE-CURRENT OR RESISTANCE MEASUREMENTS TO DETERMINE THAT EXPOSED PARTS ARE ACCEPTABLY INSULATED FROM THE SUPPLY CIRCUIT BEFORE RETURNING THE APPLIANCE TO THE CUSTOMER.

SPECIFICATIONS

Track Format: 4-tracks, 2-channels
Erasing System: AC erase
Tape Speed: 4.8 cm/sec. (1-7/8 i.p.s.)
Wow and Flutter: 0.04% (WRMS)
Frequency Response: 20-18,000Hz (Normal)
(30-17,000Hz \pm 3dB)
20-19,000Hz (High)
(30-18,000Hz \pm 3dB)
20-20,000Hz (Metal)
(30-19,000Hz \pm 3dB)



S/N Ratio: 60dB (metal tape, Dolby NR off)
A noise reduction of 10dB above 5kHz and 5dB at 1kHz is possible with Dolby B NR. A noise reduction of 20dB at 5kHz is possible with Dolby C NR.

Input Jacks: LINE IN: 2
Input sensitivity: 80mV
Input impedance: 50kohms

Outputs: LINE OUT: 2
Standard output level: 500mV (0dB) Optimum load impedance: over 50 kohms
Headphone jack: 1
Optimum load impedance: 8 to 200 ohms

Motors: DC servo motor: 1
DC motor: 2

Heads: REC/PB: Special Hard Permalloy \times 2
Erase head: Ferrite \times 1

Power Supply Rating: U.K. and Australian models: AC 240V, 50Hz
U.S.A. and Canadian models: AC 120V, 60Hz
Worldwide models: AC 120V and 220V switchable, 50/60Hz

Power Consumption: 25 watts

Dimensions: 435(W) \times 132(H) \times 366(D)mm
(17-1/8 \times 5-3/16 \times 14-3/8")

Weight: 6.8kg (15 lbs.)

Supplied Accessories: Connecting cable \times 2
RC-169K remote control transmitter
UM-4/R03/AAA battery \times 2

Specifications and external appearance are subject to change without notice because of product improvements.

BLOCK DIAGRAM

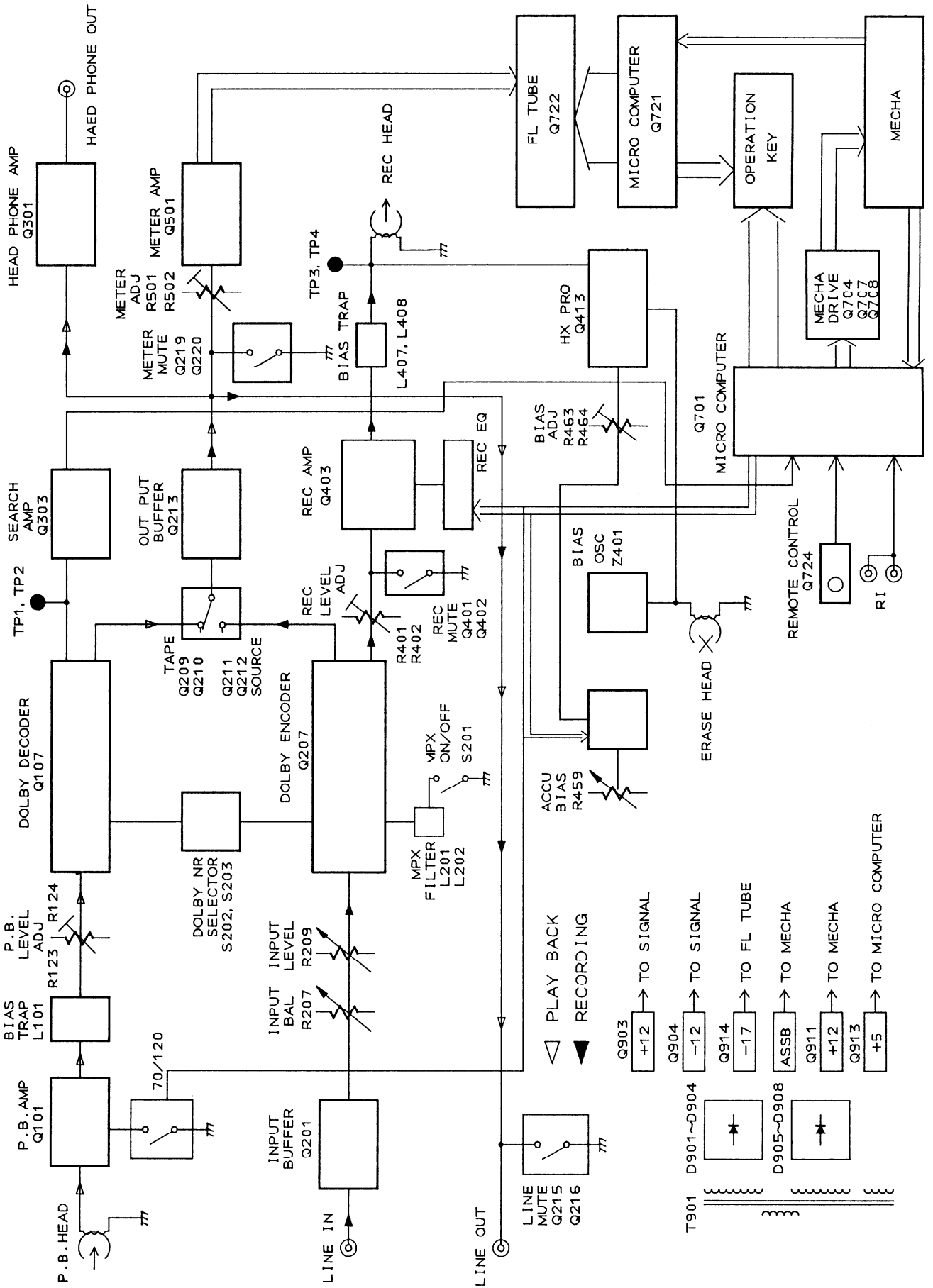

IC BLOCK DIAGRAM

CXA20187 (DOLBY NR)

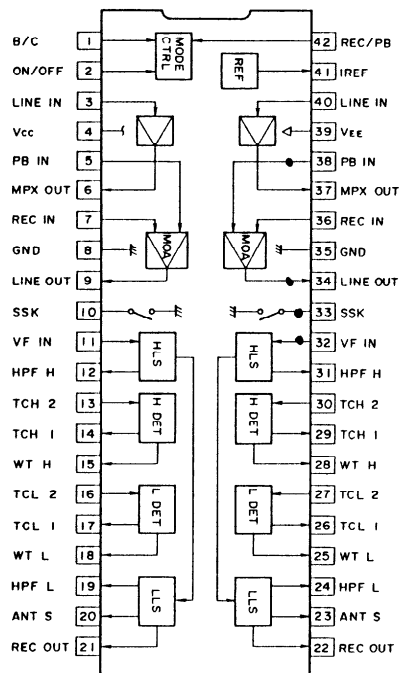

BA6800AS (METER DRIVE)

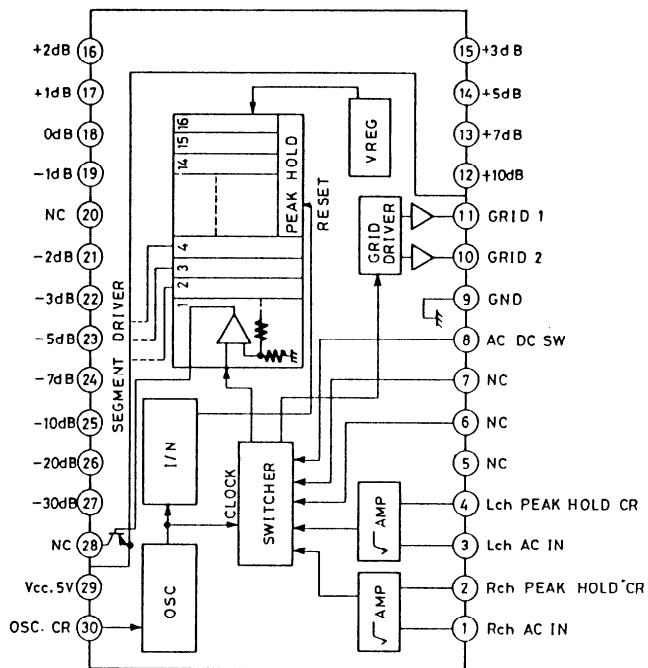

μPC1297CA (HX PRO)

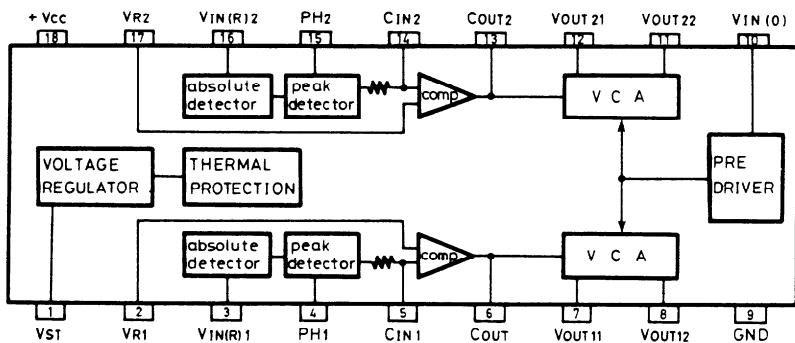

M54544AL (MOTOR DRIVE)

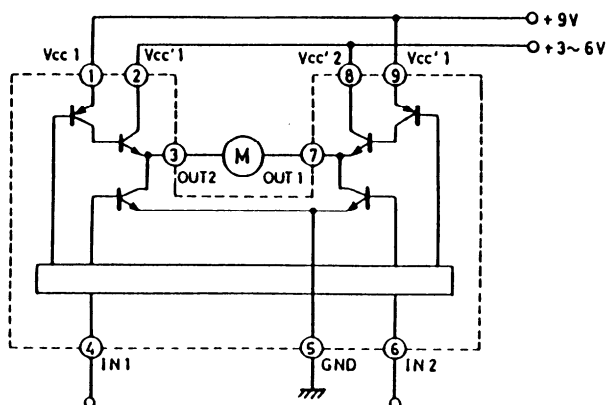

INPUT		OUTPUT		Remark
# 4	# 6	# 3	# 7	
L	L	OFF	OFF	—
H	L	H	L	FWD
L	H	L	H	REV
H	H	L	L	Brake

BG-801G (DISPLAY TUBE)

GRID ASSIGNMENT

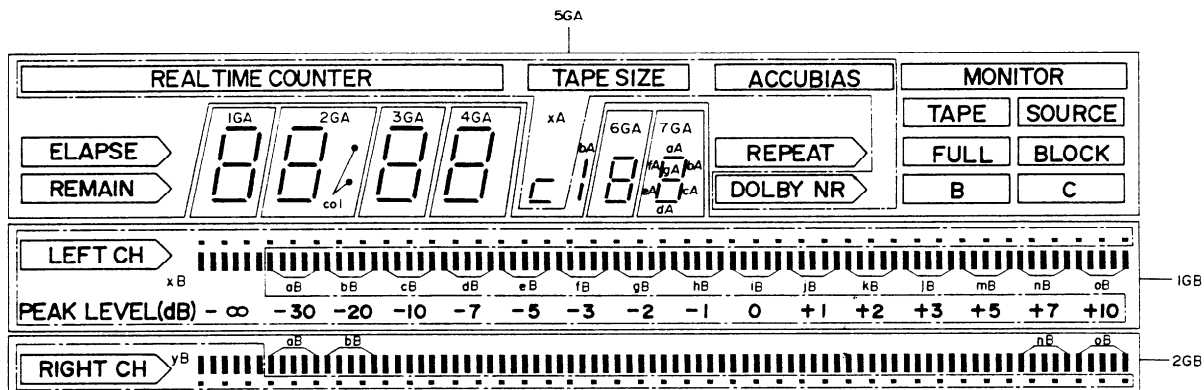

PIN CONNECTION

PIN NO.	40	39	38	37	36	35	34	33	32	31	30	29	28	27	26	25	24	23	22	21	20	19	18	17	16	15	14	13	12	11	10	9	8	7	6	5	4	3	2	1		
CONNECTION	n	o	y	x	2G	1G	N	N	N	N	h	g	f	e	d	c	b	a	j	i	7G	6G	5G	4G	3G	2G	1G	x	p	o	n	m	ℓ	k	r	q	N	N	F	F		
	B	B	B	B	B	C	C	C	C	A	A	A	A	A	A	A	A	A	A	A	A	A	A	A	A	A	A	A	A	A	A	A	A	A	A	A	A	A	P	P	1	1

PIN NO.	57	56	55	54	53	52	51	50	49	48	47	46	45	44	43	42	41
CONNECTION	F	F	N	N	a	b	c	d	e	f	g	h	i	j	k	ℓ	m
	2	2	P	P	B	B	B	B	B	B	B	B	B	B	B	B	B

Note 1.)NP.....No pin.
 2.)NC.....No connection
 3.)F1,F2.....Filament
 4.)1GA~7GA.....Grid
 5.)1GB~2GB.....Grid

ANODE CONNECTION

	1GA	2GA	3GA	4GA	5GA	6GA	7GA		1GB	2GB
aA	aA	aA	aA	aA	-	aA	aA	aB		
bA	bA	bA	bA	bA	/	bA	bA	bB		
cA	cA	cA	cA	cA	-	cA	cA	cB		
dA	dA	dA	dA	dA	-	dA	dA	dB		
eA	eA	eA	eA	eA	-	eA	eA	eB		
fA	fA	fA	fA	fA	-	fA	fA	fB		
gA	gA	gA	gA	gA	-	gA	gA	gB		
hA	-	col	-	-	-	-	-	hB		
iA	-	-	-	-	REMAIN	-	-	iB		
jA	-	-	-	-	ELAPSE	-	-	jB		
kA	-	-	-	-	REPEAT	-	-	kB		
ℓA	-	-	-	-	MONITOR	-	-	ℓB		
mA	-	-	-	-	TAPE	-	-	mB		
nA	-	-	-	-	SOURCE	-	-	nB		
oA	-	-	-	-	FULL	-	-	oB		
pA	-	-	-	-	BLOCK	-	-			
qA	-	-	-	-	B	-	-			
rA	-	-	-	-	C	-	-			
					REAL TIME COUNTER					
					TAPE SIZE					
					ACCUBIAS					
					DOLBY NR					
xA	-	-	-	-		-	-	xB		PEAK LEVEL (dB) ~ +10
								yB		RIGHT CH

A B C D E F G

SCHEMATIC DIAGRAM (2/2)

- NOTE**
- THE COMPONENTS IDENTIFIED BY MARK Δ ARE CRITICAL FOR SAFETY.
 - REPLACE ONLY WITH PART NUMBER SPECIFIED. VOLTAGE (NO INPUT SIGNAL).
 - ALL CAPACITORS ARE IN PP/50MV UNLESS OTHERWISE NOTED.
 - ALL RESISTORS ARE IN OHMS 1/4 WATT UNLESS OTHERWISE NOTED.
 - EXHAUSTIVE LISTING OF PARTS AND VALUES ARE ON THE PRINTING SIDE OF THE PARTS.
 - CIRCUIT IS SUBJECT TO CHANGE FOR IMPROVEMENT.

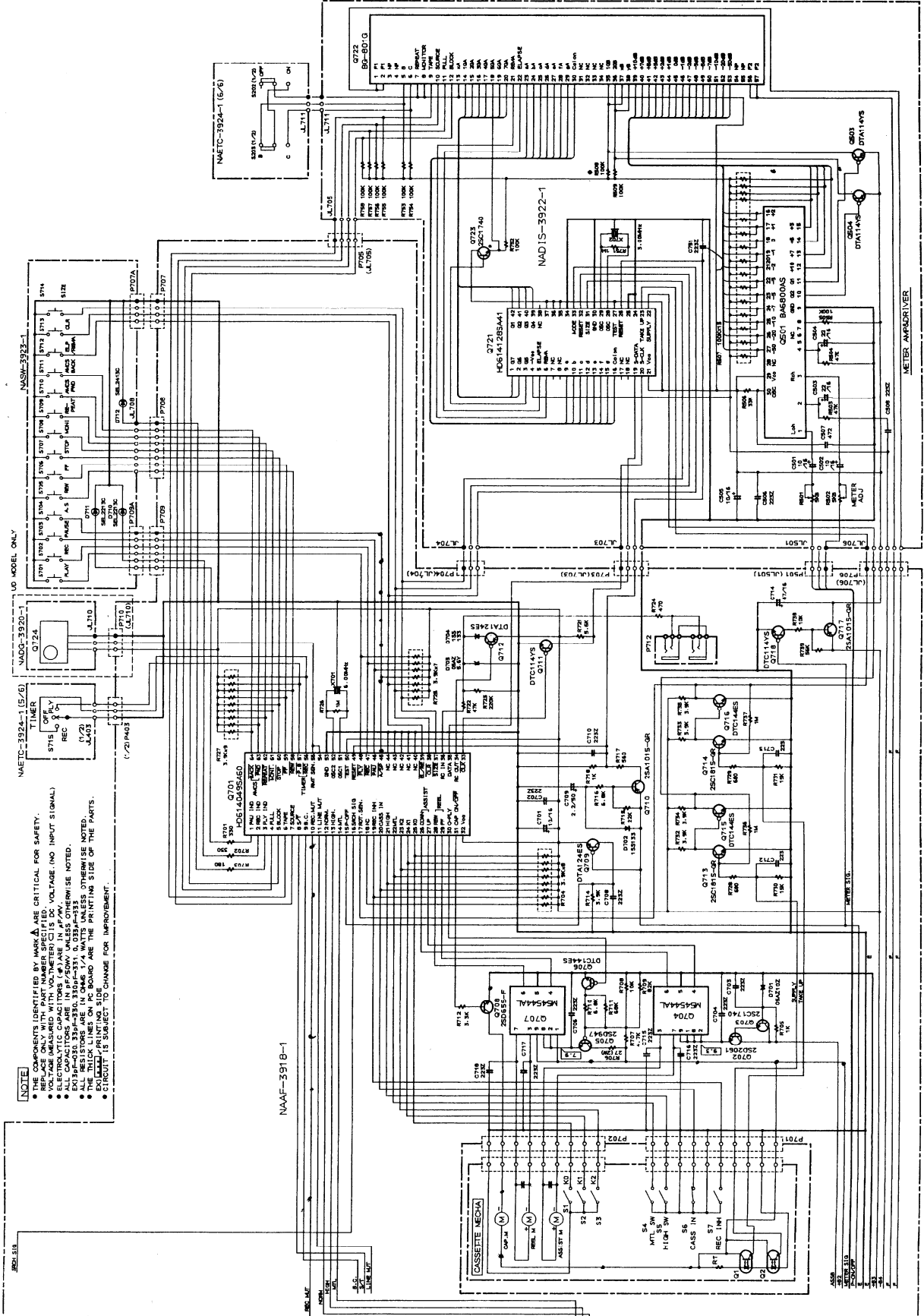

SCHEMATIC DIAGRAM (1/2)

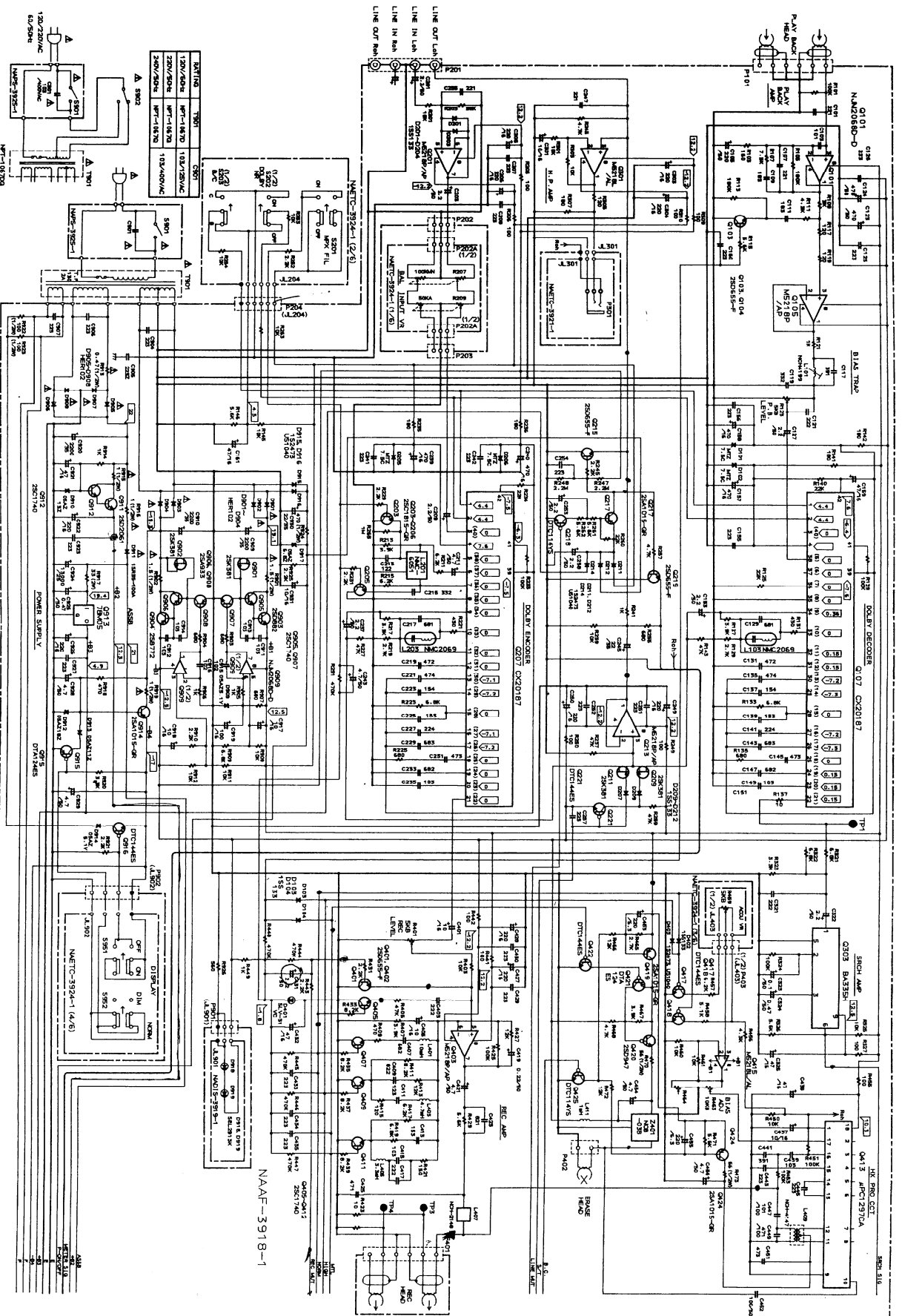

A B C D E F G

1 2 3 4 5

TAPE MECHANISM-EXPLODED VIEW

A B C D E F G

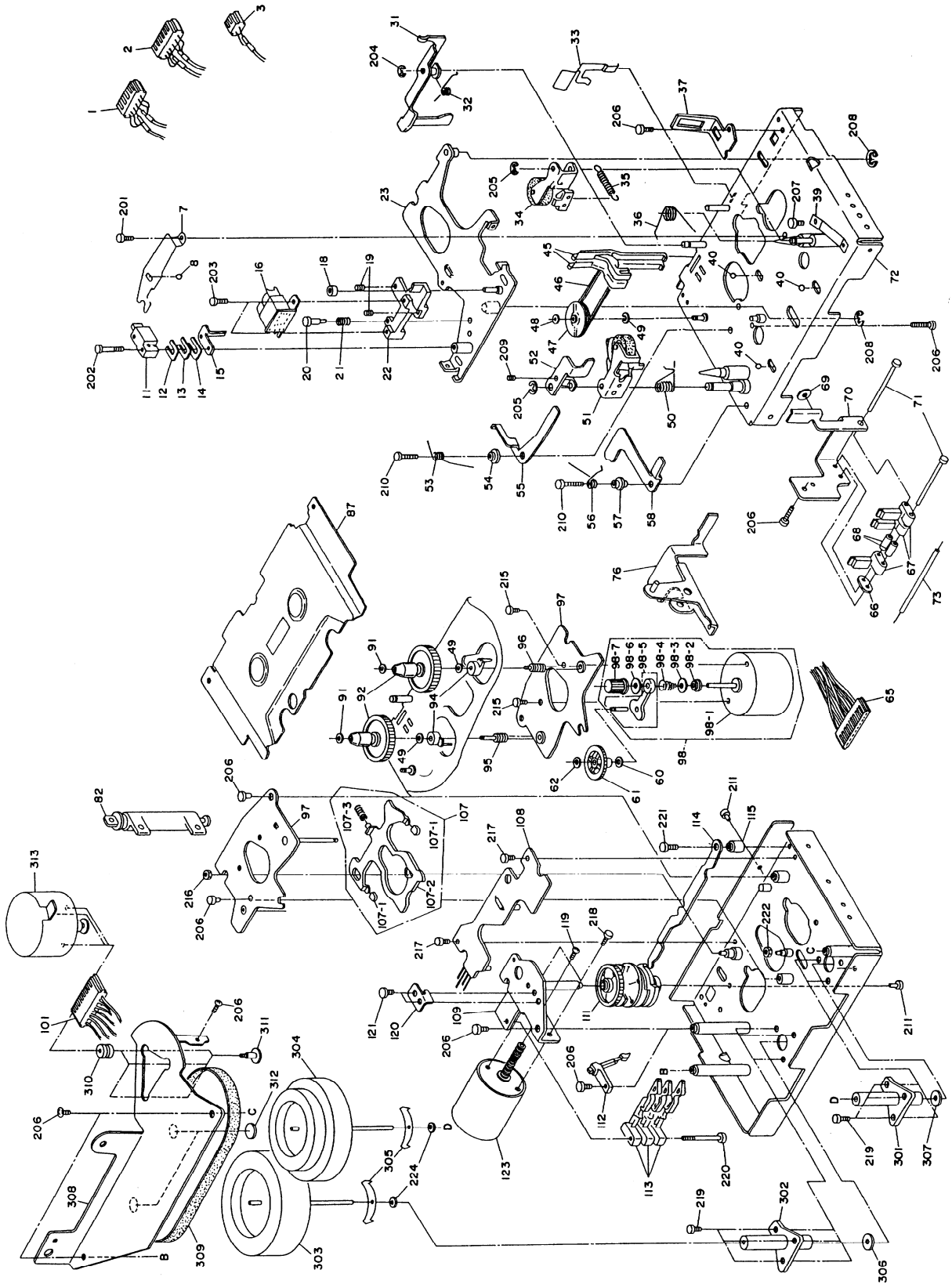

1 2 3 4 5

MECHANICAL POSITION CORD

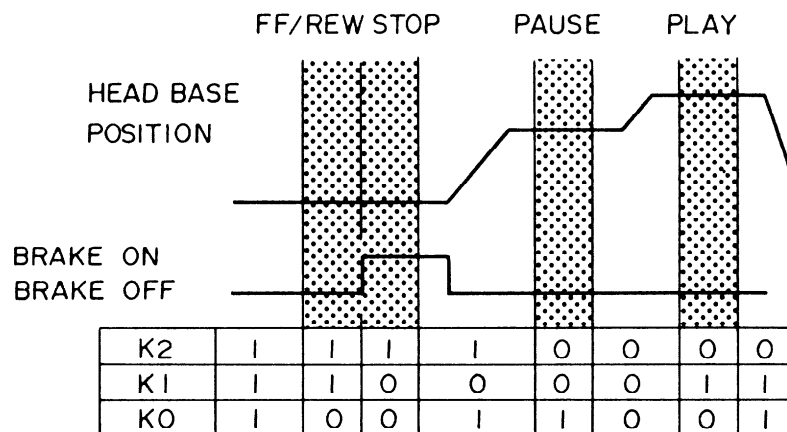

PACKING VIEW

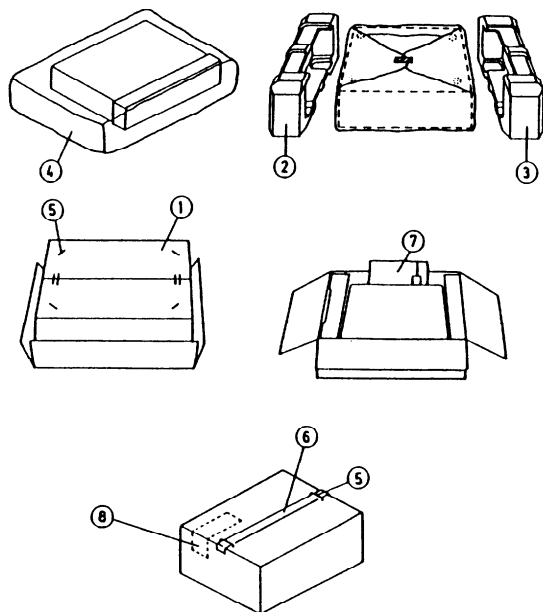

REF.NO.	PARTS NO.	DESCRIPTION
1	29052089A	Master carton box
2	29091264A	Pad (L)
3	29091265A	Pad (R)
4	29095608	Protection sheet
	29100105	620×550 Poly bag
5	282301	Sealing hook
6	29110071-1	Damplon tape
7	Accessory bag ass'y	
	29341540	Instruction manual (D/Q)
	29341541	Instruction manual (G/W/F)
	2010098A	Connection cable
	29100006A	350×250 Poly bag
	29365019	Warranty card (N)
	29365024	Warranty card (F)
	25055018	CV plug CV-K-1 (W)
	24140169	RC-169K, Remote control (D)
	3010124	UM-4, Batteries× (D)
	29358002H	Service station list (N)

NOTE: (D): Only 120V model
 (N): Only U.S. A. model
 (W): Only Worldwide model
 (F): Only France model
 (Q): Only 240V model

PRINTED CIRCUIT BOARD PARTS LIST

NAAF-3918-1

CIRCUIT NO.	PART NO.	DESCRIPTION	CIRCUIT NO.	PART NO.	DESCRIPTION
	ics				
Q101	222956	NJM-2068D-D	Q715, Q716	221282 or 2213560	DTC144ES or RN1204
Q105	222808 or 22240369	M5218P or M5218AP	Q717	2211455	2SA1015-GR
Q107	222999	CX-20187	Q718	221281 or 2213570	DTC114YS or RN1207
Q201	222808 or 22240369	M5218P or M5218AP	Q901, Q902	2212304 or 2212305	2SK381-D or 2SK381-E
Q207	222999	CX-20187	Q903	2201285 or 2201286	2SD882-Q or 2SD882-P
Q213	222808 or 22240369	M5218P or M5218AP	Q904	2201275 or 2201276	2SB772-Q or 2SB772-P
Q301	222652 or 22240368	M5218L or M5218AL	Q905, Q907	2213284 or 2213285	2SC1740S-R or 2SC1740S-S
Q303	222940	BA335H	Q906-Q908	2213354 or 2213355	2SA933S-R or 2SA933S-S
Q403	222808 or 22240369	M5218P or M5218AP	Q911	2202115 or 2202116	2SD2061-E or 2SD2061-F
Q413	222959	μ PC1297CA	Q912	2213284 or 2213285	2SC1740S-R or 2SC1740S-S
Q415	222652 or 22240368	M5218L or M5218AL	Q914	2211455	2SA1015-GR
Q701	22240361	HD614049SA60	Q915	2212600	DTA124ES
Q704	222953	M-54544AL	Q916	221282 or 2213560	DTC144ES or RN1204
Q707	222953	M-54544AL			
Q909	222956	NJM-2068D-D			
Q913	222780055MIT	78M05			
	Transistors			Diodes	
Q103, Q104	2211706	2SD655-F	D101, D102	224450753	MTZ7.5C
Q203-Q206	2211255	2SC1815-GR	D103, D104	223163	1SS133
Q209-Q212	2212304 or 2212305	2SK381-D or 2SK381-E	D201-D204	223163	1SS133
Q215, Q216	2211706	2SD655-F	D205, D206	224450753	MTZ7.5C
Q217	2211455	2SA1015-GR	D207-D210	223163	1SS133
Q218	221281 or 2213570	DTC114YS or RN1207	D211, D212	223124 or 223150	1S2473 or US1040
Q219, Q220	2211706	2SD655-F	D214	223124 or 223150	1S2473 or US1040
Q221	221282 or 2213560	DTC144ES or RN1204	D401	225227	SLV-31VC
Q401, Q402	2211706	2SD655-F	D402	223163	1SS133
Q405-Q412	2213284 or 2213285	2SC1740S-R or 2SC1740S-S	D403	223124 or 223150	1S2473 or US1040
Q417, Q418	221282 or 2213560	DTC144ES or RN1204	D701	224451004 or 224151004	MTZ10D or 05AZ10R
Q419	2211455	2SA1015-GR	D702	223163	1SS133
Q420	2201540	2SD947	D703	224150562	05AZ5.6Y
Q421	2212600	DTA124ES	D704	223163	1SS133
Q422	221282 or 2213560	DTC144ES or RN1204	D901-D904	22380029	HER102
Q424	2211455	2SA1015-GR	D905-D908	22380029	HER102
Q425	221281 or 2213570	DTC114YS or RN1207	D909	224150512	05AZ5.1Y
Q702	2202115 or 2202116	2SD2061-E or 2SD2061-F	D910	224151303	05AZ13Z
Q703	2213284 or 2213285	2SC1740S-R or 2SC1740S-S	D911	22380027	1SR35-100A
Q705	2201540	2SD947	D912	224151803	05AZ18Z
Q706	221282 or 2213560	DTC144ES or RN1204	D913	224151103	05AZ11Z
Q708	2211706	2SD655-F	D914	224150512	05AZ5.1Y
Q709	2212600	DTA124ES	D915, D916	223124 or 223150	1S2473 or US1040
Q710	2211455	2SA1015-GR	D917	224150683	05AZ6.8Z
Q711	221281 or 2213570	DTC114YS or RN1207		Coils	
Q712	2212600	DTA124ES	L101, L102	231147	NCH-4199
Q713, Q714	2211255	2SC1815-GR	L103, L104	233382	NMC-2069
			L201, L202	233328	NMC-6051
			L203, L204	233382	NMC-2069
			L401, L402	231089	NCH-2137
			L403, L404	231085	NCH-2133
			L405, L406	231083	NCH-2131
			L407, L408	231101	NCH-2148
			L409, L410	231100	NCH-4147
			L411	231077	NCH-2125
			Z401	231149	NOB-038

CIRCUIT NO.	PART NO.	DESCRIPTION	CIRCUIT NO.	PART NO.	DESCRIPTION
X701	Ceramic osc 3010149	CST6.00MGW	R123, R124	Resistors 5210216	N06HR5KBD
C101, C102	Capacitors 372122214	220PF50V, ST.	R401, R402	5210216	N06HR5KBD
C105, C106	391982217	220 μ F50V, ELECT.	R463, R464	5210217	N06HR10KBD
C123, C124	391984717	470 μ F50V, ELECT.	R470	442525604F	RS1/2WBJ 56 Ω
C127, C128	391980227	2.2 μ F50V, ELECT.	R473	442525604F	RS1/2WBJ 56 Ω
C153, C154	391980227	2.2 μ F50V, ELECT.	R704	49163392408	3.9K Ω \times 8, 1/10W
C157, C158	391944717	470 μ F16V, ELECT.	R706	441722704F	RS2WBJ27 Ω
C159, C161	391944707	47 μ F16V, ELECT.	R725	49163392407	3.9K Ω \times 7, 1/10W
C201-C204	391980227	2.2 μ F50V, ELECT.	R727	49163392409	3.9K Ω \times 9, 1/10W
C205, C206	391942217	220 μ F16V, ELECT.	R901, R902	442520154F	RS1/2WBJ 1.5 Ω
C209, C210	391980227	2.2 μ F50V, ELECT.	R913	442524794F	RS1/2WBJ 0.47 Ω
C211, C212	391980477	4.7 μ F50V, ELECT.	R915, R916	442520104F	RS1/2WBJ 1 Ω
C237, C238	391980227	2.2 μ F50V, ELECT.	R917	441723304F	RS2WBJ 33 Ω
C239, C240	391944717	470 μ F16V, ELECT.	R919	442520104F	RS1/2WBJ 1 Ω
C243	391980477	4.7 μ F50V, ELECT.	R922, R923	442521014F	RS1/2WBJ 100 Ω
C245, C246	391962207	22 μ F35V, ELECT.	R924	442524714F	RS1/2WBJ 470 Ω
C249, C250	391942217	220 μ F16V, ELECT.		Plug, Socket	
C253	391980227	2.2 μ F50V, ELECT.	P101	25055136	NPLG-6P120
C258	391980227	2.2 μ F50V, ELECT.	P201	25045165	4PDBL-59
C301, C302	391941007	10 μ F16V, ELECT.	P202, P203	25055147	NPLG-3P131
C303, C304	391942217	220 μ F16V, ELECT.	P204	25050270	NSCT-6P98
C322	391980227	2.2 μ F50V, ELECT.	P401	25055136	NPLG-6P120
C323	391981097	0.1 μ F50V, ELECT.	P402	25055132	NPLG-2P116
C324	391984797	0.47 μ F50V, ELECT.	P403	25050270	NSCT-6P98
C325	391944707	47 μ F16V, ELECT.	P501	25050267	NSCT-3P95
C401, C402	391941007	10 μ F16V, ELECT.	P701	25055139	NPLG-9P123
C405, C406	391941007	10 μ F16V, ELECT.	P702	25055140	NPLG-10P124
C419, C420	391982297	0.22 μ F50V, ELECT.	P703	25050268	NSCT-4P96
C421, C422	391980477	4.7 μ F50V, ELECT.	P704	25050267	NSCT-3P95
C427, C428	391942217	220 μ F16V, ELECT.	P705	25050268	NSCT-4P96
C431	391980227	2.2 μ F50V, ELECT.	P706	25050270	NSCT-6P98
C432	391944707	47 μ F16V, ELECT.	P707	25055134	NPLG-4P118
C437	391941007	10 μ F16V, ELECT.	P708	25050272	NSCT-8P100
C438	391944707	47 μ F16V, ELECT.	P709	25055444	NPLG-6P426
C453, C455	391922217	220 μ F6.3V, ELECT.	P710	25050267	NSCT-3P95
C454, C456	391980477	4.7 μ F50V, ELECT.	P712	25045172	HSJ1003-01-020
C701	391941007	10 μ F16V, ELECT.	P901	25050267	NSCT-3P95
C709	391980227	2.2 μ F50V, ELECT.	P902	25050268	NSCT-4P96
C714	391944707	47 μ F16V, ELECT.		Miscellaneous	
C909, C910	391962227	2200 μ F35V, ELECT.		27141059	BRACKET, EARTH
C917, C918	391941007	10 μ F16V, ELECT.		27160029-1	RAD-078, RADIATOR
C919	391941017	100 μ F16V, ELECT.		27160211-1	RAD-68B, RADIATOR
C920	391962227	2200 μ F35V, ELECT.		27160211	RAD-68, RADIATOR
C921	391944707	47 μ F16V, ELECT.		27160029	RAD-07, RADIATOR
C922	391942217	220 μ F16V, ELECT.		82143006	3P+6FN(BC), SCREW
C925	391984797	0.47 μ F50V, ELECT.			
C926	391942217	220 μ F16V, ELECT.			
C928, C929	391980477	4.7 μ F50V, ELECT.			
C930	393062207	22 μ F35V, ELECT.			
C931	391941007	10 μ F16V, ELECT.			

MICRO COMPUTER (HD614049SA60)

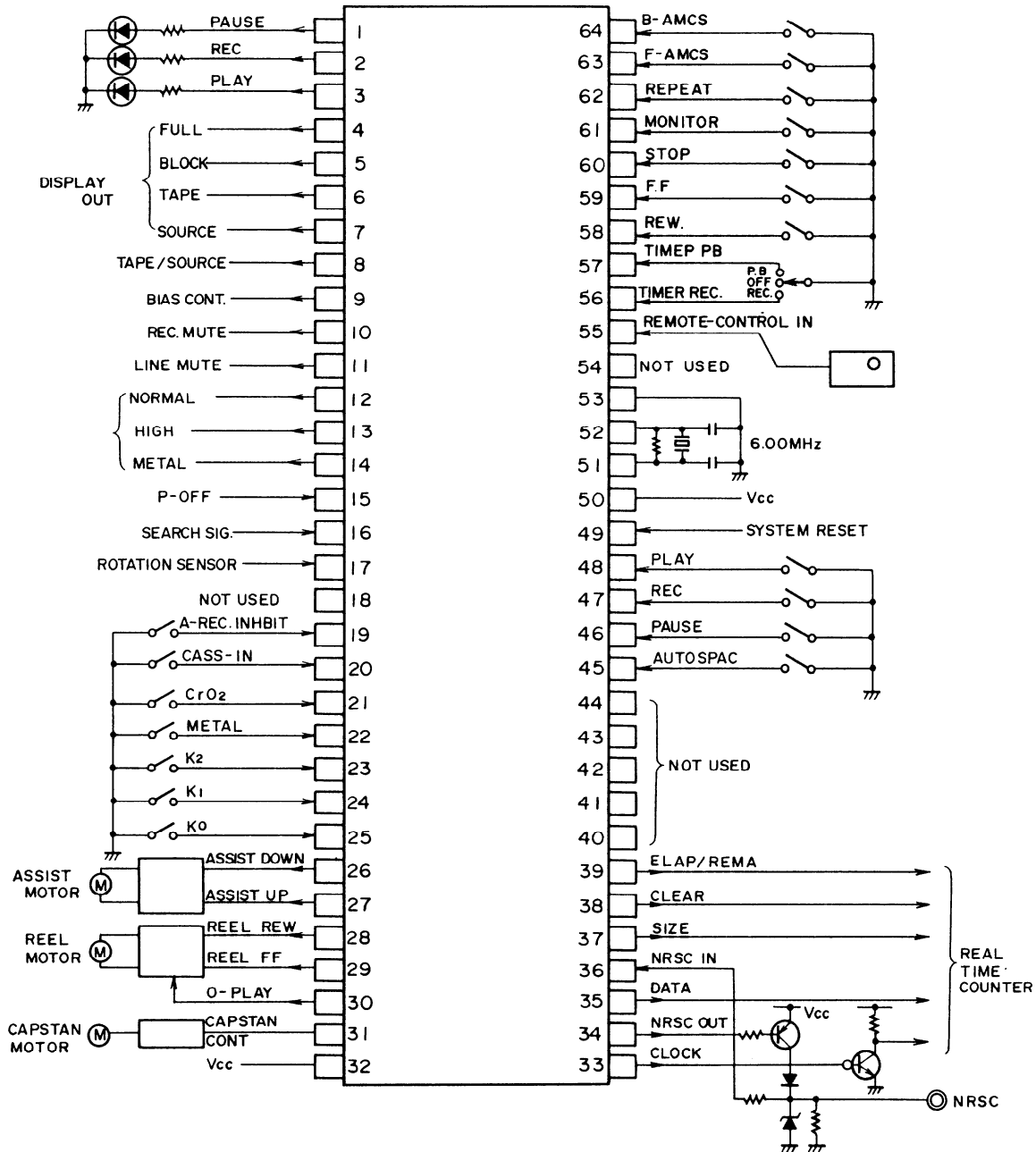

MICRO COMPUTER (HD614049SA60)

Port No.	Name	Function
1	PAUSE LED	Pause indicator output
2	REC. LED	Record indicator output
3	PLAY LED	Play indicator output
4	FULL	Full repeat indicator output
5	BLOCK	Block repeat indicator output
6	TAPE	Tape monitor indicator output
7	SOURCE	Source monitor indicator output
8	TAPE/SOURCE	Monitor (tape/source) select output
9	BIAS CONTROL	Bias oscillator control output
10	REC. MUTE	Record muting output
11	LINE MUTE	Line muting output
12	NORMAL	Normal tape end detection output
13	HIGH	High tape end detection output
14	METAL	Metal tape end detection output
15	P-OFF	Power off detection input
16	SEARCH SIG.	Search signal input
17	ROTATION SENSOR	Reel rotation signal sensor input
18	NOT USED	
19	SIDE-A REC. INHIBITING	Side-A record inhibit pin sensor
20	CASSETTE IN	Cassette tape sensor switch input
21	CrO2	Tape type sensor switch input
22	METAL SWITCH	Tape type sensor switch input
23~25	MECHA. POSITION K2~K0	Mecha position sensor switch input
24	ASSIST DOWN	Assist motor drive output
27	ASSIST UP	Assist motor drive output
28	REEL REW	Reel motor REW rotation control output
29	REEL FF	Reel motor FF rotation control output
30	O-PLAY	Reel motor rotation torque control output
31	CAPSTAN CONTROL	capstan motor control output
32	V _{cc}	+5V
33	CLOCK	Master-slave communication clock output
34	NRSC OUT	serial code reciprocal control signal out
35	DATA OUT	Master-slave communication data output
36	NRSC IN	Serial code reciprocal control signal input
37	COUNTER SIZE	Tape size select output
38	COUNTER CLEAR	Tape counter clear output
39	COUNTER ELAP/REMA	Tape elapse/remain select output
40~44	NOT USED	
45	AUTO SPACE KEY	Auto space key input
46	PAUSE KEY	Pause key input
47	REC KEY	Record key input
48	PLAY KEY	Play key input
49	SYSTEM RESET	Computer system reset
50	TEST	
51, 52	OSC1, OSC2	System clock oscillator terminal
53	GND	
54	NOT USED	
55	REMOTE-CONTROL IN	Remote control signal input
56	TIMER REC.	Timer record input
57	TIMER PB.	Timer play input
58	REW KEY	REW key input
59	FF KEY	FF key input
60	STOP KEY	Stop key input
61	MONITOR KEY	Monitor select key input
62	REPEAT KEY	Repeat key input
63	F-AMCS KEY	FWD play search signal input
64	B-AMCS KEY	REV play search signal input

ADJUSTMENT PROCEDURES

PRECAUTIONS

- Before adjustment, clean the following parts with an alcohol moistened swab.
 - * record/playback head
 - * pinch roller
 - * erase head
 - * capstan
- Do not use magnetized screwdriver for adjustments.
- Demagnetize record/playback head with a head demagnetizer.

TEST EQUIPMENT/TOOLS REQUIRED:

Audio oscillator
 Digital frequency counter
 Oscilloscope
 Attenuator
 AC voltmeter
 Non-magnetic screw driver
 Test tapes
 TCC-153 : 10 KHz, -10dB
 MTT-111 : 3 kHz, -10dB
 MTT-150 : Dolby level calibration
 400Hz, tone 200nWb/m

Item	Connection of instrument	Line input	Test tape	Mode	Output indicator	Adjustment point	Adjust	Remarks	
1	Tape speed	Frequency counter to LINE output terminal	MTT-111	PB	Frequency counter	Semi-fixed on the motor	3,005 to 3,010Hz		
2	Head azimuth	AC voltmeter and oscilloscope to Line output terminal	TCC-153	PB	AC voltmeter	Head azimuth screw	Maximum and same phase at channels L and R		
3	Playback level	AC voltmeter to terminals TP-L and TP-R	MTT-150	PB	AC voltmeter	R-123 (Ch. L) R-124 (Ch. R)	245mV		
4	Meter		MTT-150	PB	Level meter	R-501 (Ch. L) R-502 (Ch. R)	0db	NAAF-3922	
5	HX-PRO	AC voltmeter to terminals TP-3 and TP-4	METAL TAPE	REC	AC voltmeter	L-409 (Ch.L) L-410 (Ch.R)	Maximum	R-463 R-464 MAX	
6	Bias current	AC voltmeter to LINE output terminal	1kHz, -20dB and 12kHz, -20dB	NEW XL-II90	REC/PB	AC voltmeter	R463 (Ch.L) R464 (Ch.R)	Same level at REC/PB	Input VR maximum.
7	Record level	1kHz		REC	AC voltmeter	Attenuator or AF OSC output	350mV	Input VR maximum	
				REC/PB	AC voltmeter	R401 (Ch.L) R402 (Ch.R)	Same level at REC/PB		
8	Bias trap	AC voltmeter to LINE output terminal	METAL TAPE	REC	AC voltmeter	L-101 (Ch. L) L-102 (Ch. R)	Min bias leakage		

Blank tape
 NORMAL ... NEW UD-1 C-90
 HIGH ... XL-II C-90
 METAL ... MX C-60
 PLAY torque ... 35~60g/cm
 FF. REW torque ... 70~180g/cm
 Back tension ... 2~7g/cm

ADJUSTMENT POINT

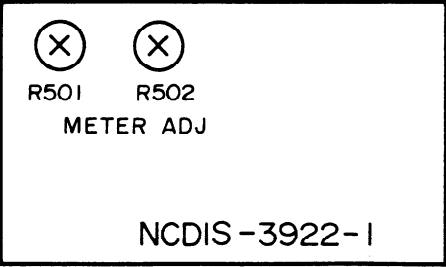
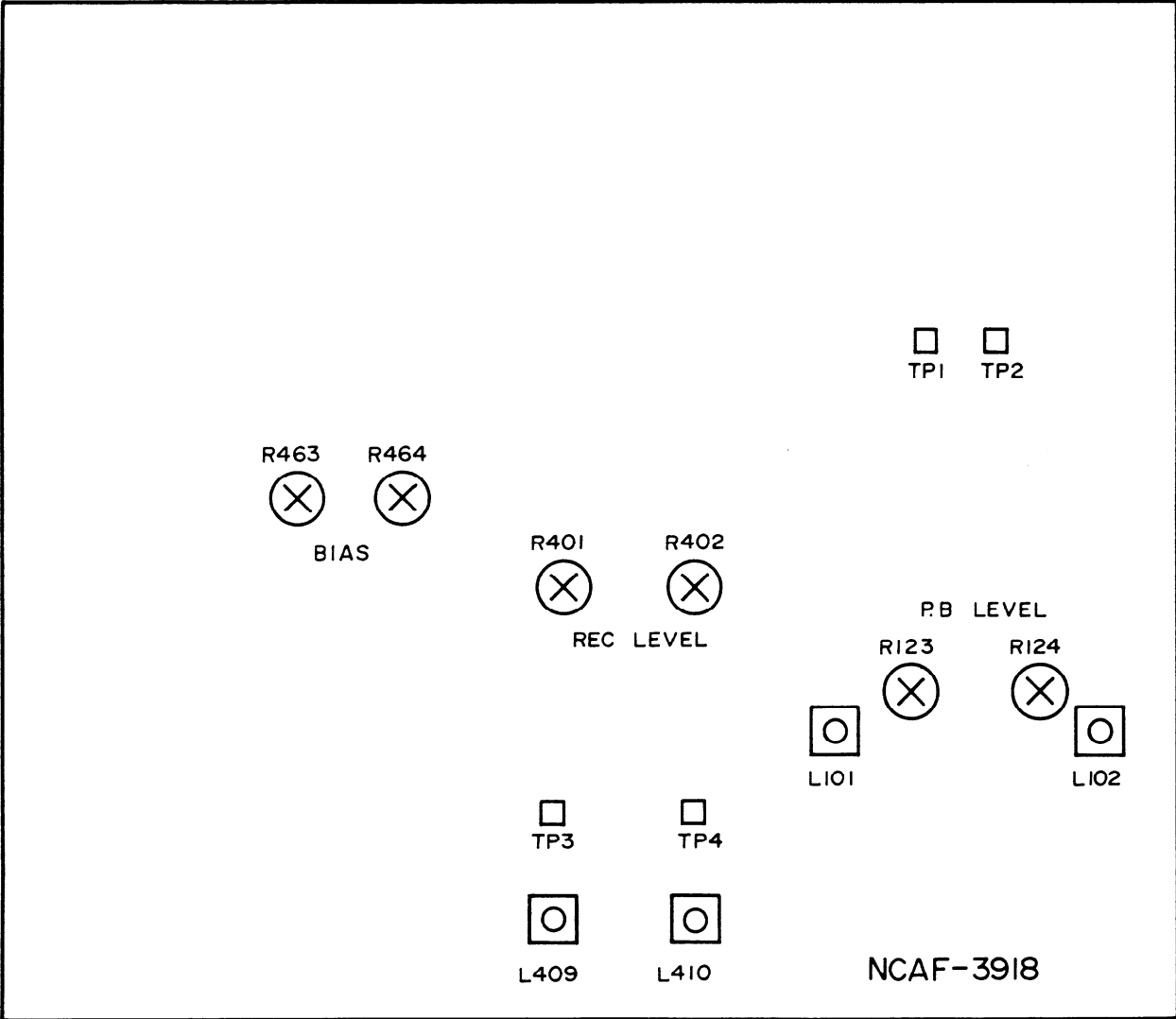

CHASSIS-EXPLODED VIEW

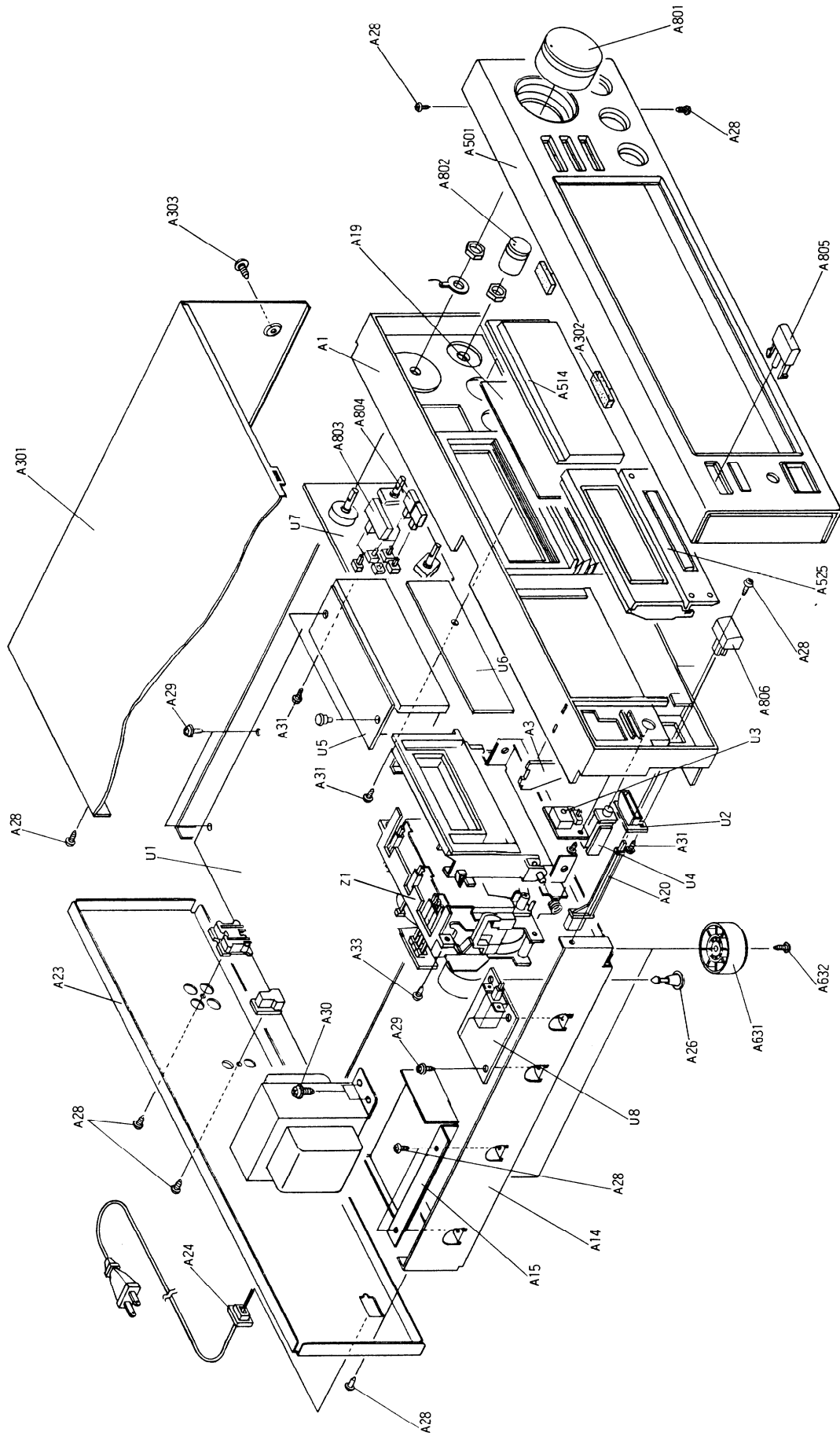

CHASSIS-EXPLODED NEW PART LIST

REF.NO.	PARTS NO.	DESCRIPTION	REF.NO.	PARTS NO.	DESCRIPTION
A1	27110574	FRONT BRACKET AS	P901	253112A	AC CORD AS-UC-4 (D)
A3	27273131	JOINT (EJ)		253149	AC CORD AS-CEE (G/W)
A13	28141062	CUSHION 20×10×6t		253118	AC CORD AS-SAA (Q)
A14	27100210C	CHASSIS		2300527A	NPT-1067D (D)
A15	27130608-1A	BRACKET (PT)	T901	2300528A	NPT-1067G (G)
A17	28140881	CUSHION		2300529B	NPT-1067DG (W)
A19	28133243A	BACK PLATE	S902	2300530A	NPT-1067Q (Q)
A20	27273069A	JOINT (POW)	U1	25065123	NSS-1258P (W)
A23	27121358	BACK PANEL (D)		1N090518-1	NAAF-3918-1 (D)
	27121359	BACK PANEL (G)		1N090518-1A	NAAF-3918-1A (G/W/Q)
	27121361	BACK PANEL (W)	U2	1N090519-1	NADIS-3919-1
	27121393	BACK PANEL (Q)	U3	1N090520-1	NADG-3920-1
A24	27300750	BUSHING (CORD)	U4	1N090521-1	NAETC-3921-1
A26	27190524	HOLDER	U5	1N090522-1	NADIS-3922-1
A28	834430088	TAP-TIGHT SCREW	U6	1N090523-1	NASW-3923-1
		3TTS+8B(BC)	U7	1N090524-1	NAETC-3924-1
A29	831130088	TAP-TIGHT SCREW 3TTW+8B	U8	1N090525-1	NAPS-3925-1
A30	830440069	TAP-TIGHT SCREW	W901	2061112200	CRIMP CORD AS
		4TTC+6C(BC)	W902	2061112300	CRIMP AS
A31	833430080	TAP-TIGHT SCREW	Z1	244143	CASSETTE DECK MECHANISM NDM-135
		3TTP+8P(BC)			
A32	831430100	TAP-TIGHT SCREW			
		3TTW+10P(BC)			
A33	838426088	TAP-TIGHT SCREW			
		2.6TTB+8B(BC)			
A301	28184401	TOP COVER			
A302	28140198	CUSHION 40×10×0.5t			
A303	838440089	TAP-TIGHT SCREW			
		4TTB+8C(BC)			
A501	1N090121UD	FRONT PANEL			
A514	28191559	CLEAR PLATE			
A525	28400597B	CASSETTE LID AS			
-a	28400593	CASSETTE LID			
-b	28400595A	CASSETTE LID			
-c	28400596	WINDOW			
-d	28194334	COSMETIC PLATE (WINDOW)			
A631	27175153-1	LEG			
A801	28323395A	KNOB (LEV)			
A802	28323979	KNOB (BAL)			
A803	28323981B	KNOB (PUSH)			
A804	28323983A	KNOB (DOL)			
A805	28323985	KNOB (EJ)			
A806	28323987	KNOB (POW)			

NOTE: (D): Only 120V model
 (G): Only 220V model
 (W): Only Worldwide model
 (Q): Only 240V model

NOTE: THE COMPONENTS IDENTIFIED BY MARK **△**
 ARE CRITICAL FOR RISK OF FIRE AND
 ELECTRIC SHOCK. REPLACE ONLY WITH
 PART NUMBER SPECIFIED.

TAPE MECHANISM PART LIST

REF.NO.	PARTS NO.	DESCRIPTION	REF.NO.	PARTS NO.	DESCRIPTION
1	24606441	LEAD WIRE AS	98	24601261	REEL MOTOR AS
2	24606442	LEAD WIRE AS	98-1	24601169	REEL MOTOR
3	24606443	LEAD WIRE AS	98-2	24611048	SPRING STAND
7	24611481	PLATE (HEAD)	98-3	24610374	WASHER
8	24610943	STEEL BALL 3	98-4	24605467	SPRING
11	24600084	E HEAD	98-5	24602471	IDLER AS
12	24611060	SPACER 0.06t	98-6	24610970	FELT
13	24611061	SPACER 0.03t	98-7	24602237A	GEAR (MOTOR)
14	24611062	SPACER 0.1t	101	24606445	LEAD WIRE AS
15	24610653	BRACKET B (E HEAD)	107	24611043	BRAKE PLATE AS
16	24600082	R/P HEAD	107-1	24610999	BRAKE RUBBER
18	24610495	ADJUSTING NUT	107-2	24611053A	BRAKE PLATE
19	801251	SCREW M2×4	107-3	24605472	SPRING
20	24610652	SHAFT	108	24606446	P. C. B. AS (SENSOR)
21	24605502	SPRING	109	24611482	BRACKET AS
22	24611046	HEAD BLOCK	111	24602532	CAM GEAR
23	24611064	HEAD BASE AS	112	24606104	LEAF SWITCH
31	24603284	LEVER (READER)	113	24606119	L.F.A.F SWITCH
32	24605506	SPRING	114	24611075	CONNECTING PLATE
33	24605507	SPRING (CASSETTE)	115	24604064	COLLAR
34	24602270	PINCH ROLLER AS	119	24611483	THRUST WASHER (B)
35	24605244	SPRING	120	24611484	THRUST WASHER
36	24605709	SPRING	121	24609047	TAP-TIGHT SCREW
37	24610659A	PROTECTOR	123	24601263	PAD MOTOR AS
39	24605188	SPRING (CASSETTE)	201	833130047	TAP-TIGHT SCREW M3×4
40	24610351	STEEL BALL (CHASSIS 22)	202	82512012	BIND SCREW M2×12
45	24603205	LEVER (REC)	203	801250	PAN-HEAD SCREW M2+4SW
46	24602271	BELT	204	8930251	E WASHER
47	24601167	PULLEY AS	205	8930201	E WASHER
48	24611003	WASHER 1.8×3.8×0.5	206	833125069	SCREW
49	24611047	WASHER 2.1×4.5×0.1	207	801292	TAP-TIGHT SCREW M2×3.2
50	24605707	SPRING	208	893030	E WASHER 3
51	24602478	PINCH ROLLER AS	209	801263	SCREW M2×3
52	24611065	LEVER (ADJUSTING)	210	24609014	SCREW M2.5×8
53	24605510	SPRING	211	801325	PAN HEAD SCREW M2+5 SW
54	24604065	COLLAR	215	82512603	BIND SCREW
55	24603286	LEVER (SELECTOR)	216	863720	NUT N-2BSNI
56	24605710	SPRING	217	83312604	TAP-TIGHT SCREW M2.6×4
57	24604052	COLLAR	218	801259	SCREW M2+3
58	24611066	LOCK PLATE	219	833125059	TAP-TIGHT SCREW M2.5+20
60	24611141	WASHER 1.7×6×0.25	221	833126127	TAP-TIGHT 2.6TTP+12S
61	24602531	GEAR	222	863126	NUT N-2.6F
62	24610969	WASHER	224	24610515	WASHER
65	24606447	LEAD WIRE AS	301	24611372	STAND AS (CAPSTAN)
66	24611057	WASHER	302	24611373	STAND AS (CAPSTAN)
67	24606205	LEAF SWITCH	303	24602472	FLYWHEEL
68	24604063	COLLAR	304	24602473	FLYWHEEL
69	24611142	WASHER 2.7×5×0.5	305	24605452	SPRING (THRUST)
70	24611068	BRACKET (SW)	306	24611485	WASHER
71	82112030	PAN HEAD SCREW	307	24611486	WASHER
72	24611370	MECHANISM CHASSIS AS	308	24611376	BRACKET
73	24606444	LEAD WIRE	309	24602476	BELT
76	24603285	LEVER (CANCEL)	310	24610723	CUSHION
82	24611380	DUMPER UNIT	311	24609015	SCREW (MOTOR)
87	24611476A	BACK PLATE (CASSETTE)	312	24611377	THRUST WASHER
91	24610349	WASHER 1.8×3.2×0.5	313	24601264	CAPSTAN MOTOR AS
92	24602534	REEL AS			
94	24611072	SPRING STAND			
95	24605505	SPRING			
96	24605501	SPRING			
97	24611371	BRACKET AS (MOTOR)			

FRAME (CASSETTE) EXPLODED VIEW PART LIST

REF.NO.	PARTS NO.	DESCRIPTION
1	24611451A	PLATE AS (S)
2	24605748	SPRING (L)
3	24605749	SPRING (R)
4	24611452	PLATE (K)
5	24611457	CUSHION (A)
6	24611450	PLATE (A)
7	24611455	HOLDER (L)
8	24611456	HOLDER (R)
9	24605750A	SPRING
10	801437	TAPPING SCREW
11	24611459	PLASTIC WASHER
12	24611453A	SIDE BRACKET AS (L)
13	24611454A	SIDE BRACKET (R)
14	24611476A	BACK PLATE (CASSETTE)
15	2461458	CUSHION (B)
16	24603285	LEVER (CANCEL)
17	8761401005	WASHER FW 4 × 10 × 0.5 t
18	833425059	TAP-TIGHT SCREW 2.5TTP+5C (BC)
19	893030S	E WASHER 3
20	833426039	TAP-TIGHT SCREW 2.6TTP+3C (BC)
21	24605753	SPRING
22	831126068	TAPPING SCREW 2.6TTW+6B (BC)
23	24611480	COVER (FW)
24	24605747	SPRING (EJECT)
25	24611380	DUMPER UNIT
26	891024	STOP RING

FRAME (CASSETTE) EXPLODED VIEW

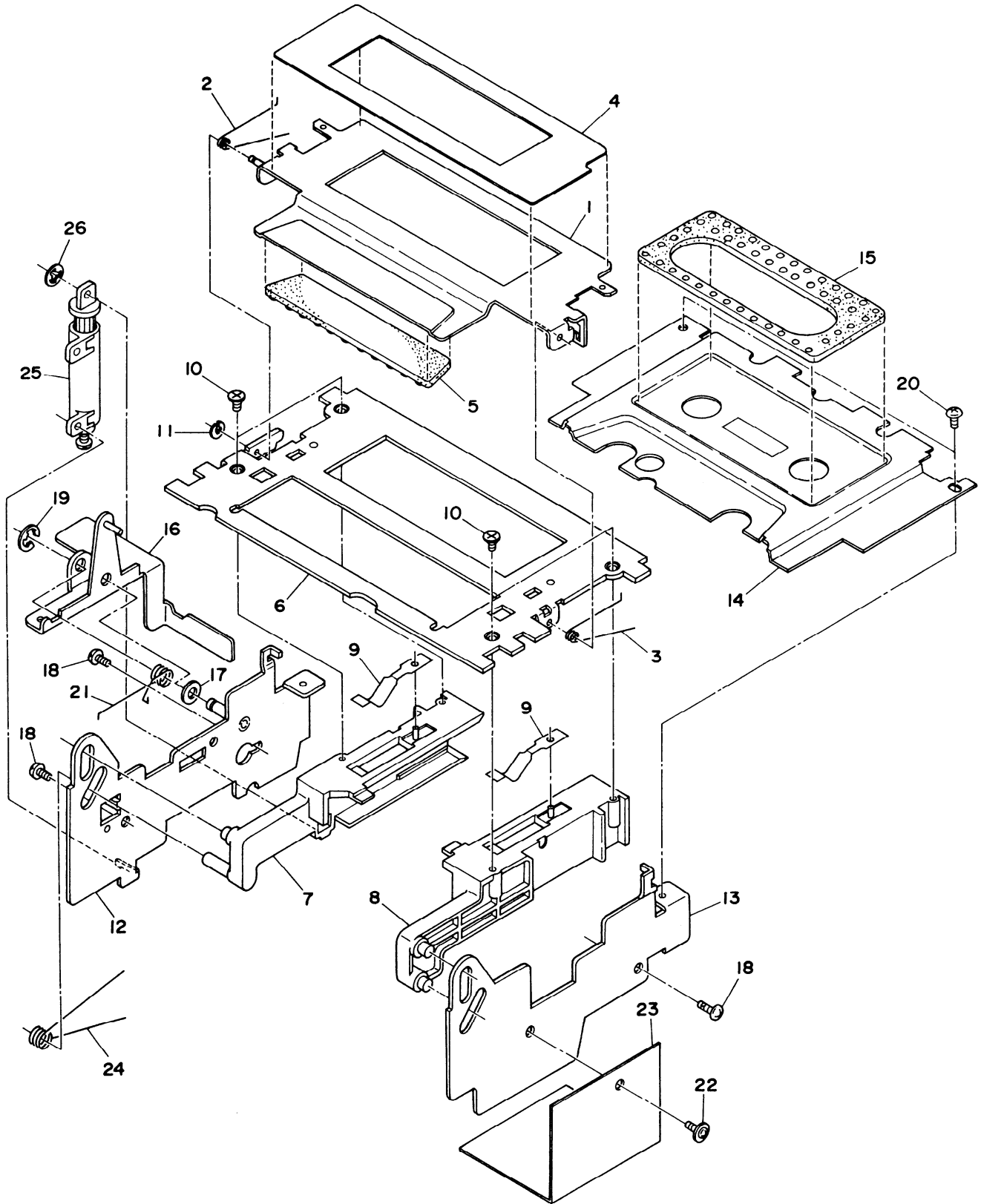

PRINTED CIRCUIT BOARD PARTS LIST

NADIS-3919-1

CIRCUIT NO.	PART NO.	DESCRIPTION
	LED	
D918, D919	225142	SEL2913K
	Holder	
	27190454A	HOLDER(PLED)

NADG-3920-1

CIRCUIT NO.	PART NO.	DESCRIPTION
Q724	24130003	GPIU50XS

NAETC-3921-1

CIRCUIT NO.	PART NO.	DESCRIPTION
P301	25045139	HLJ0540-01-010

NADIS-3922-1

CIRCUIT NO.	PART NO.	DESCRIPTION
	ic	
Q501	22240170	BA6800AS
Q721	22240084	HD614128SA41
	Display	
Q722	212086	BG-801G
	Transistor	
Q503, Q504	2213090	DTA114YS
	Ceramic osc	
X702	3010143	CST3.00MGW
	Capasitor	
C501, C502	391941007	10 μ F16V, ELECT.
C503, C504	391942207	22 μ F16V, ELECT.
C505	391941007	10 μ F16V, ELECT.
	Resistor	
R501, R502	5215044	N08HR5KBC
R507	49163104415	100k Ω ×15, 1/10W
	Miscellaneous	
	27130611	BRACKET(FL)
	880009	NRP-345, REVET

NASW-3923-1

CIRCUIT NO.	PART NO.	DESCRIPTION
	LED	
D710, D711	225141	SEL2213C
D712	225137CG, 225137DG or 225137DY	SEL2413CG, SEL2413DG or SEL2413DY
	Switch	
S701-S714	25035548	NPS-111-510
	Socket	
P707A	2005230415	NSAS-4P0003
P709A	2006391215	NSAS-12P0131
	Holder	
	27190764	HOLDER(LED4)

NAETC-3924-1

CIRCUIT NO.	PART NO.	DESCRIPTION
	Resistor	
R207	5104268	N14RGLC100KMN25Z
R209	5104260	N16RGL50KA25Z
R459	5104271	N14RLC5KB25Z
	Switch	
S201-S203	25035514	NPS-122-L47G
S751	25030327	NRSF-113-25SRB
S951, S952	25035514	NPS-122-L476
	Socket	
P202A	2000886	NSAS-6P832

NAPS-3925-1

CIRCUIT NO.	PART NO.	DESCRIPTION
C901	3500065A	0.01 μ F, AC400V/125V, IS.
S901	25035558	NPS-111-L520P, PUSH SWITCH
	25060092	NMT-1S33, TERMINAL

ONKYO CORPORATION

International Division: Onarimon Yusen Bldg., 23-5, Nishi-Shimbashi 3-chome, Minato-ku,
TOKYO 105, JAPAN Tel: 03-432-6987 Fax: 03-436-6979 TLX: 242-3551 ONKYO J

ONKYO U.S.A. CORPORATION

200 Williams Drive, Ramsey, N.J. 07446, U.S.A. Tel: 201-825-7950 Fax: 201-825-8150

ONKYO EUROPE GMBH

Hellersbergstrasse 4, 4040 Neuss, WEST GERMANY

Tel: 02101 12 00 75 Fax: 02101 10 33 06 TLX: 85 17 916 ONDU D