

# ONKYO® SERVICE MANUAL

## STEREO CASSETTE TAPE DECK Model TA-630DM

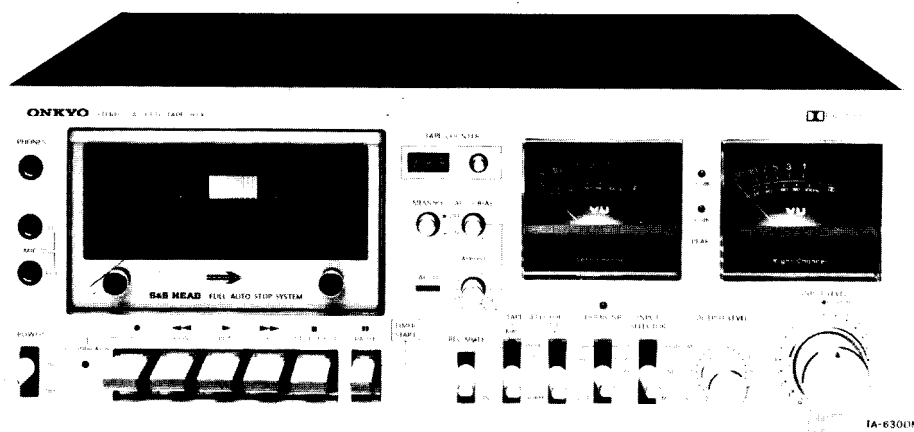

### TABLE OF CONTENTS

Item	Page
Specifications	2
Features	2
Block diagram	3
Exploded view	4
Component location	5
Circuit description	6
Mechanical operation	7
Disassembling instructions	8
Mechanism adjustment procedures	9
Electrical adjustment procedures	10
Service guide	12
Mechanism-exploded view	13
Printed circuit board view	15
Schematic diagram	17
PC board-parts list	19
Packing procedures	20

**ONKYO®**  
**AUDIO COMPONENTS**

## SPECIFICATIONS

<b>Track Format:</b>	4 track, 2 channels
<b>Erase System:</b>	AC erase
<b>Tape Speed:</b>	4.8 cm/sec
<b>Wow &amp; Flutter:</b>	0.055% (WRMS) <i>A NEW UNIT GIVES 0.06%</i>
<b>Fast Forward and Rewind Time:</b>	90 sec (C-60)
<b>Frequency Response:</b>	30 ~ 15,000 Hz Normal tape (30 ~ 14,000 Hz $\pm$ 3 dB) 30 ~ 18,000 Hz CrO <sub>2</sub> tape (30 ~ 17,000 Hz $\pm$ 3 dB) 30 ~ 20,000 Hz Metal tape (30 ~ 18,000 Hz $\pm$ 3 dB)
<b>Signal-to-Noise Ratio:</b>	60 dB (Metal tape; Dolby NR out) A noise reduction of 10dB above 5 kHz and 5 dB at 1 kHz is possible with the Dolby NR IN
<b>Transistors:</b>	40
<b>SCR:</b>	1
<b>IC:</b>	4
<b>Diodes:</b>	25 diodes, 3 LEDs
<b>Input Terminals:</b>	Microphone jacks-2 Minimum input level: 0.3 mV Input impedance: 50 k $\Omega$ Optimum mic impedance: 200 $\Omega$ ~ 50 k $\Omega$ Line in jacks-2 Minimum input level: 50 mV Input impedance: 50 k $\Omega$

<b>DIN Jacks-1</b>	Minimum input level: 0.1 mV/k $\Omega$ Input impedance: 5 k $\Omega$
<b>Output Jacks:</b>	Line out jacks-2 Standard output level: 0.775 V (0 VU) Optimum load impedance: over 50 k $\Omega$ DIN Jack-1 Standard output level: 0.775 V (0 VU) Optimum load impedance: over 50 k $\Omega$ Headphones: 8 $\Omega$ ~ 200 $\Omega$ PLL Servo DC
<b>Motor:</b>	AC 120V/60 Hz
<b>Power Supply:</b>	13 W
<b>Power Consumption:</b>	Dimensions: 418(W) x 158(H) x 297(D) mm 16-1/2" x 6-1/4" x 12"
<b>Weight:</b>	6 kg (13.2 lbs)
<b>Accessories:</b>	Pin-Pin type connecting cords - 2

- \* Specifications and design are subject to modification without prior notice for product improvements.
- \* Cabinet Composition: Embossed vinyl over metal.

## FEATURES

### High Quality Long Life "S & S" Sendust Head

Onkyo's recently developed "S & S" Sendust head (made from a highly robust silicon/iron/aluminum alloy of outstanding magnetic properties) plays a very big role in achieving the high quality of sound reproduction in the TA-630DM. Extended frequency response (20 Hz ~ 18,000 Hz with chrome tapes) and an exceptionally wide dynamic range make your recordings sound professional-like.

### Built-in Accu-Bias Control

Optimum bias level is essential for really top grade recordings. But since the magnetic characteristics of different types of tape vary from brand to brand, the conventional bias settings are only approximates. The Onkyo TA-630DM Accu-Bias control eliminates the "approx", and ensures you of superb results with every tape used, especially in the high frequency region.

### Dolby NR System with Switchable MPX Filter

Now a regular feature in all high grade cassette tape decks, the Dolby NR system eliminates much of the annoying tape hiss from your recordings. And by also incorporating the Dolby circuit in a highly reliable single-chip 2-channel monolithic IC, outstanding channel balance is achieved. Furthermore, a built-in MPX filter removes the pilot signal from FM broadcasts for brilliant high quality recordings.

### Built-in Dolby FM Decoder

With the TA-630DM you will be right up to date for recording of the increasingly popular Dolby FM broadcasts. No need for an extra adaptor, or a new tuner/receiver especially designed for Dolby FM. The improved S/N ratio makes noise practically non-existent.

### Timer Switch for Automatic Recording or Morning Alarm

By simply connecting up to an audio timer, the TA-630DM will record those "not-to-be-missed" programs even in your absence. Or then you may wish to substitute your morning alarm with some of your favorite symphonies and recording artists.

### One-Touch Rec Muting for Clean Editing

This simple switch will make a big difference to your tape recording and editing. Since tape transport will continue in a "no-signal" recording mode, the interval between tunes will be completely silent. Editing out of commercials will also be swift and clean-cut.

### Memory Rewind for Rapid Replay

After presetting the tape counter and memory rewind at a particular section of the tape, a simple push of the rewind button will return the tape back to that point quickly and accurately, saving considerable time and bother.

### Separate 3-Way Bias and Equalization Selectors

The TA-630DM is designed to handle all major types of cassette tapes available on the market today. And in combination with the Accu-Bias control, optimum bias levels are assured for every tape used.

### Full Auto-Stop Mechanism

Full automatic stop at the end of the tape safeguards both tapes and tape transport from undue strain. The TA-630DM is also equipped with an electronically controlled full auto-stop mechanism to ensure that no strain whatsoever is applied to either tape or tape transport system.

**BLOCK DIAGRAM**

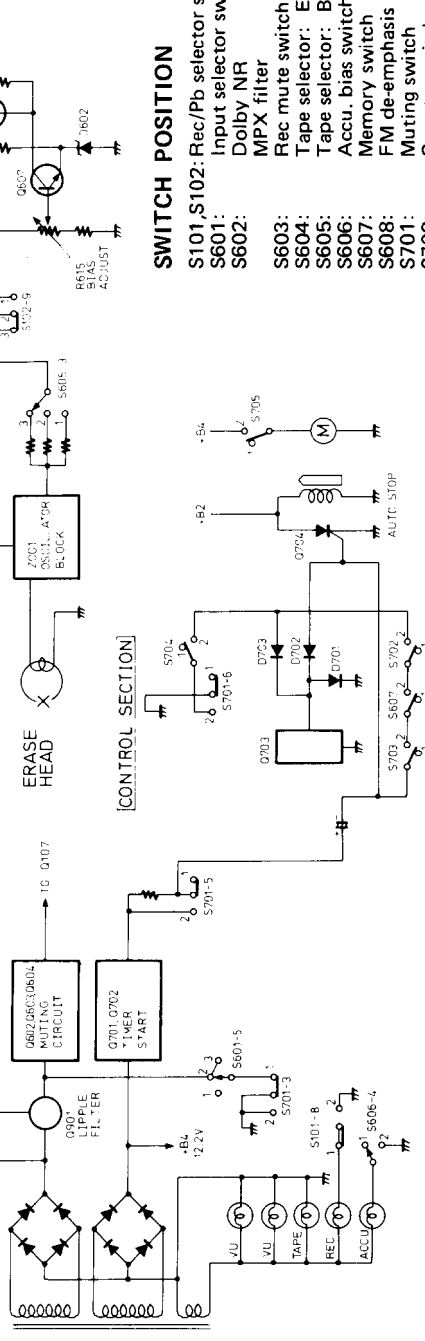
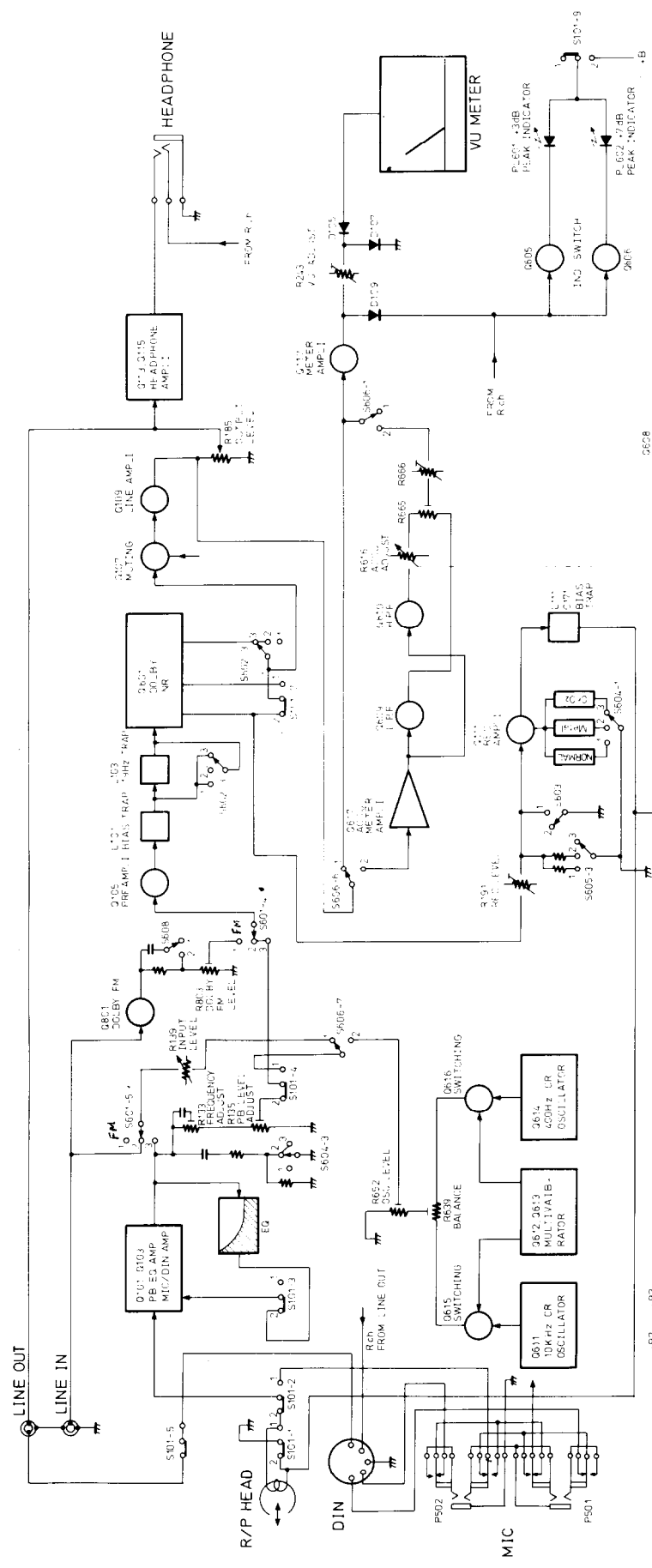

**SWITCH POSITION**

- S101,S102: Rec/Pb selector switch
- S601: Input selector switch
- S602: Dolby NR MPX filter
- S603: Rec mute switch
- S604: Tape selector: Eq
- S605: Accu. bias switch
- S606: Memory switch
- S607: FM de-emphasis switch
- S701: Muting switch
- S702: Counter switch
- S703: Rewind switch
- S704: Pause switch
- S705: Motor switch
- 1. Rec 2. Pb
- 1. Dolby FM 2. Line 3. DIN/Mic.
- 1. Out 2. In 3. In
- 1. Out 2. In 3. Out
- 1. Off 2. On
- 1. Normal 2. Metal 3. CrO2
- 1. Normal 2. Metal 3. CrO2
- 1. Off 2. On
- 1. Off 2. On
- 1. 25μsec 2. Normal
- 1. Stop 2. Play
- 1. Off 2. On
- 1. Off 2. On
- 1. Off 2. On
- 1. Off 2. On

## EXPLODED VIEW

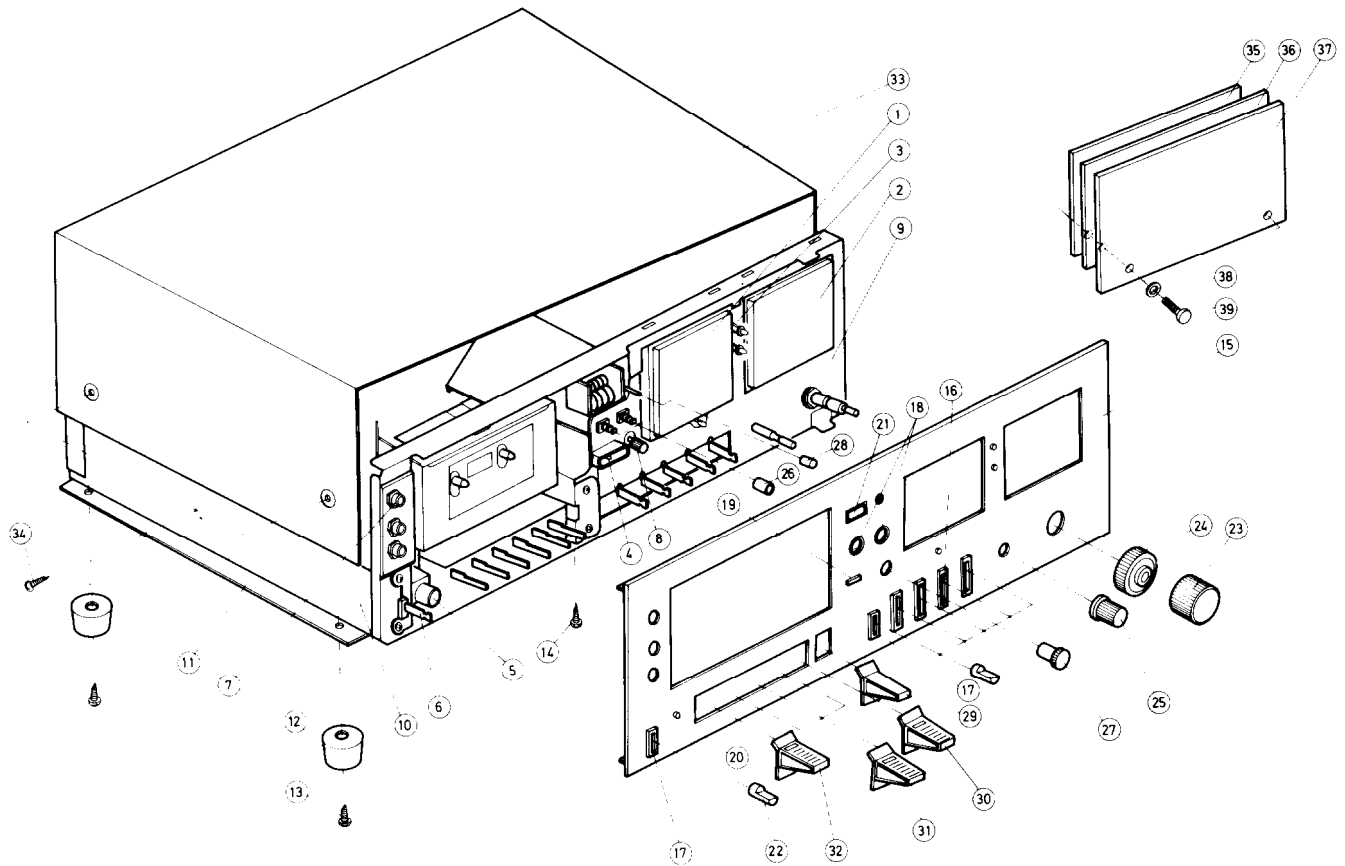

## EXPLODED VIEW-PARTS LIST

REF. NO.	PARTS NO.	DESCRIPTION	REF. NO.	PARTS NO.	DESCRIPTION
1	243107	NIND-0500S107, VU meter	18	27267007	Guide (PUSH)
2	243108	NIND-0500S108, VU meter	19	28198506	Facet
	210066	0.1A, 6.3V, VU meter lamp	20	28198510	Facet
3	16449542	NAPL-542, Peak indicator p.c.b.	21	27300148A	Window for counter
4	210034	RMS-6V-50, Accu. indicator lamp	22	28320344	Knob, lever
5	210035	RMS-6V-50, Rec. indicator lamp	23	28320345	Knob (R)
6	25040058	NLS-111-2715-L23P, Power switch	24	28320346	Knob (L)
7	25045046	HLJ0264-01-070, Stereo headphone jack	25	28320347	Knob (OUT)
8	5148031	N16RGC2KB25, Accu. control variable resistor	26	28320348	Knob, push
9	27110066	Front bracket	27	28320290	Knob, volume
10	27115027B	Side bracket	28	28320289	Knob, push
11	27170023-1	Bottom board	29	28320223A	Knob, lever
12	27175009	Leg	30	28320222A	Knob, lever
13	831130102	3STW+10BQ, Tapping screw	31	28320220A	Knob, lever
14	831430082	3STW+8BQ(BC), Tapping screw	32	28320221A	Knob, lever
15	27210137-1	Front panel	33	28184022	Top cover
	16379121	Front panel ass'y	34	838440109	4TTB+10C (BC)
16	27267024A	Guide (A)	35	27300088	Cassette cover
17	27267025A	Guide (B)	36	27300089A	Cassette plate
			37	27300091B	Cover
			38	870052	Washer
			39	801173B	Decorative screw

## COMPONENT LOCATION

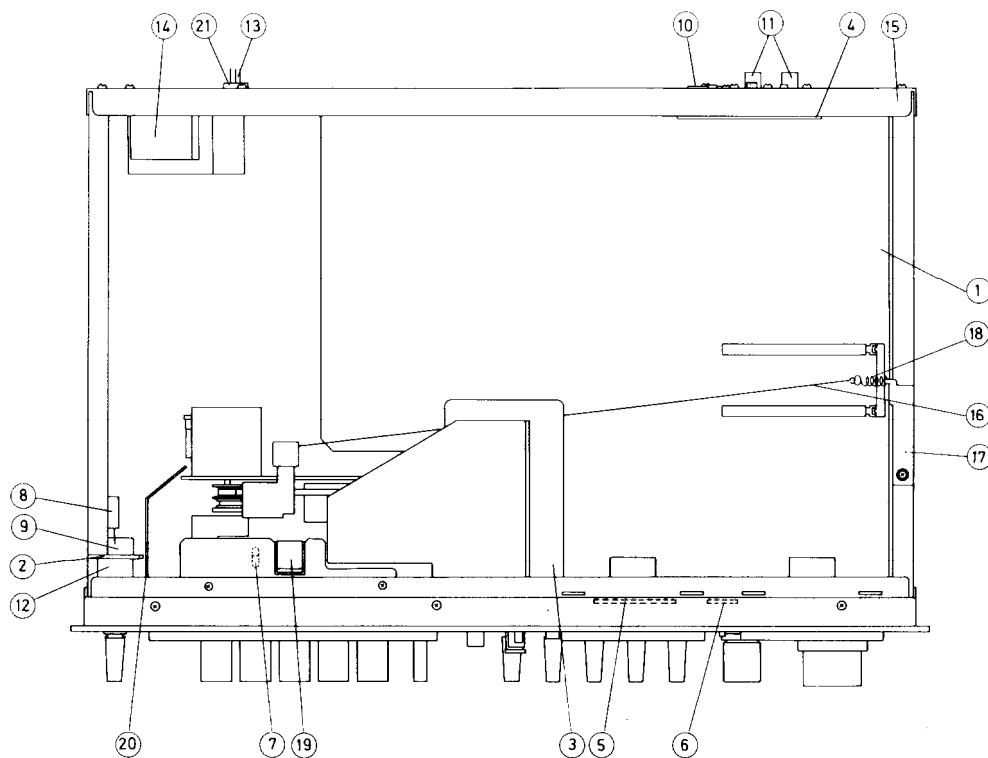

## COMPONENT LOCATION-PARTS LIST

## U.S.A. model

REF. NO.	PARTS NO.	DESCRIPTION
1	16379538A	NAAF-538a, Rec. and Pb. amplifier p.c.b.
2	16481569	NASW-469, Mic. Jack p.c.b.
3	16449543	NASW-543, Memory, rewind and accu. switch p.c.b.
4	16449540	NASW-540, Dolby FM p.c.b.
5	16449539	NAPL-539, Dolby NR indicator p.c.b.
6	16449542	NAPL-542, Peak indicator p.c.b.
7	210043	RMS-6V-50, Deck illumination lamp
8	3500057	UL125V103M, ULCS capacitor
9	25040058	NLS111-2715-L23P, Power switch
10	250008	ST-3312, DIN socket
11	25045025	NPJ-4PRBL03, Input/output terminal
12	25045046	HLJ0264-01-070, Stereo Headphone jack
13	253099A	AS-UC3, Power supply cord
14	230408	NPT-712D, Power transformer
15	27120129-1	Back panel
16	27180027	Spring
17	27140180A	Lever (A)
18	27180022	Spring
19	244008-1	Deck ass'y
20	27300098	Shielded plate
21	270025	SR-3P4, Strainrelief

## CIRCUIT DESCRIPTION

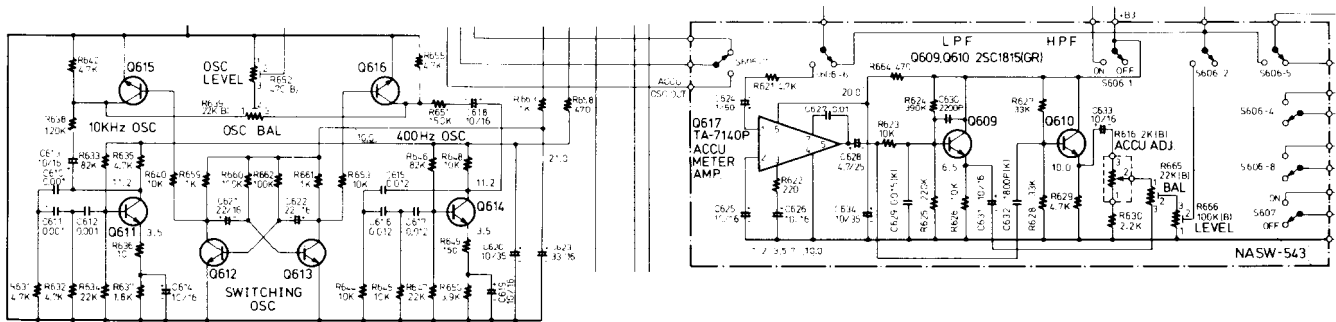

### 1. Accurate Bias Circuit

Optimum bias current varies according to the type of tape being employed. Too little bias current will result in increased distortion, while too much bias current will result in deterioration of the frequency response. For this reason, the TA-630D has been equipped with an Accu Bias Control (front panel) which permits optimum bias currents to be set accurately for different tapes.

A major feature of the TA-630D is the Accu-Bias circuit which permits optimum bias adjustments for every individual cassette tape used, thereby ensuring recordings of very flat frequency responses.

1. Insert a blank tape into the cassette compartment, and set the Tape Selectors accordingly.
2. For Accu-Bias adjustments, the Dolby NR switch must always be in the Out position.
3. When starting at the beginning of a new tape, press the ►► FF key to advance the tape by 20 ~ 30 in the Tape Counter. (This will ensure optimum bias adjustment).
4. Press the ■■ Pause key, and then the ● Rec and ► Play keys to prepare the deck for recording mode.
5. Press the Memory push-button (On position).
6. Reset the Tape counter to 000.
7. Press the Accu-Bias push-button (On position). The Accu-indicator lamp will consequently light up.
8. Turn the Accu-Bias Adjust control to the "0" (click-stop) position.
9. Check that the meter pointers deflect across to around the 0 VU position. Since the internal oscillator generates alternate 400 Hz and 10 kHz (-20 VU) signals.
10. Release the ■■ Pause key, and record for a count of 5 to 10.
11. Press the ◀◀ Rew key. The tape will rewind back to 000 and stop automatically.
12. Press the ► Play key to playback the tape.
13. Turn the Accu-Bias Adjust control around in either direction to find the position where the meter pointers again swing back and forth with minimum amplitude. This adjustment will now correspond to the optimum bias setting for that particular tape.
14. Leaving the Accu-Bias Adjust control in the adjusted position, press the Accu-Bias push-button a second time to disengage the Accu-Bias circuit. Now proceed with the regular recording.

**During recording:** Q611, C610 ~ C612, R631, R632 and R634 constitute a 10 kHz CR oscillator circuit, while Q614, C615 ~ C617, R644, R645, and R647 constitute a 400 Hz oscillator circuit. By using a non-stable multivibrator, Q612 and Q613 switch the 10 kHz and 400 Hz signals back and forth at approximately 2 second intervals (Q613 is turned OFF when Q612 is turned ON, and vice versa). When Q612 is turned ON, the collector voltage drops, resulting in Q615 being cut OFF. And since Q613 has already been cut OFF, Q616 will be turned ON, resulting in the 10 kHz signal passing out through the ACCU OSC output. When Q613 is then turned ON, Q612 is cut OFF immediately, resulting in the 400 Hz signal appearing at the output. These output signals (alternate 10 kHz and 400 Hz signals of equal levels) are then passed to the recording amplifier (Q111) prior to being recorded on tape.

**During playback:** The recorded signals are passed via a playback equalizer amplifier, a preamplifier, and a line amplifier. The 400 Hz signal is passed via the R623/C629 low-pass filter and Q609, on to the meter drive circuit. The 10 kHz signal, on the other hand, is passed via the C632/R628 high-pass filter and Q610, on to the Accu Bias Level VR (coupled to the front panel Accu Bias Control) before being mixed in the meter drive circuit. Then optimum bias is selected for that particular tape by adjusting the Accu Bias Control to make the levels of the 400 Hz and 10 kHz signals equal.

### 2. Timer Start

- (1) Set the time of the timer unit plugged into the AC mains.
- (2) Press the record key and/or the play key, and also the pause key. Then turn the power switch on.
- (3) The power supply will thus come on at the preset time.
- (4) C701 will consequently be charged up via R702, resulting in Q701 being turned ON some 4 seconds later.
- (5) Q702 will therefore turn OFF.
- (6) The signal will pass via S701 and C702, on to the gate of Q704.
- (7) Q704 will thus be turned ON.
- (8) The charge on C707 will then be discharged through solenoid and Q704, which is thereby activated.
- (9) The pause key is released by this solenoid action, resulting in the start of the recording, or playback, mode.

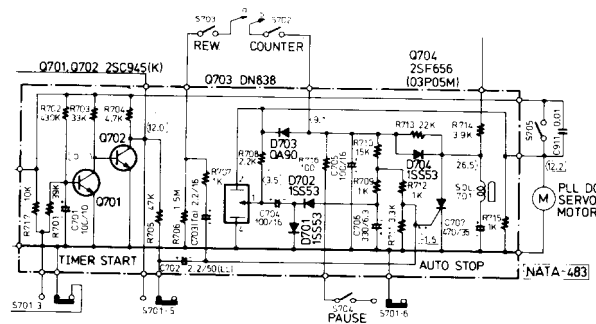

### 3. Memory Rewind

- (1) Press the reset button to return the counter to 000.
- (2) Then press the memory button.
- (3) Then commence operation in playback or record modes, but not rewind.
- (4) After reaching any desired position on the tape, press the rewind key.
- (5) Since the deck is now in memory rewind mode, S703 and S704 will be ON. And when the tape exceeds the original starting position (counter at 999) the counter switch S702 will also turn ON.
- (6) The voltage at point (3) in the circuit diagram will then increase from 0 to 12V, this signal being applied to the gate of Q704 via R707 and C703.
- (7) Q704 will thus be turned ON.
- (8) The charge on C707 will then discharge via the solenoid and Q704, thereby activating the solenoid.
- (9) The depressed keys are thus released by the activated solenoid.
- (10) Upon completion of the C707 discharge, Q704 will be turned OFF. C707 will then commence to charge up again via the SOL701 solenoid to be prepared for subsequent operations.

### 4. Auto Stop

- (1) A magnet connected to a counter, which in turn is connected to the take-up reel via a counter belt, is rotated during tape transport.
- (2) This rotating magnet consequently results in the generation of square wave output signals from the Q703 Hall IC (4).
- (3) These signals are rectified by D701 and D702, smoothed by C706, and then applied to the gate of Q704 (5) which is thus kept at a negative potential.
- (4) Once the tape stops, the Q703 output signals will cease.
- (5) C706 will thus be charged up via R714, R713, R710, and R709, resulting in an increase in voltage.
- (6) Q704 will consequently turn ON if the gate (5) potential exceeds 0.6V (approx.)
- (7) The charge on C707 will then discharge via Q704 and the solenoid. The solenoid is thus activated, releasing the depressed keys, and bringing tape transport to a halt.
- (8) After C707 has completely discharged, Q704 will turn OFF. C707 will then recommence to charge up again via the R714 solenoid in order to be ready for the next auto-stop operation. This charge up time is approximately 3 seconds.

## MECHANICAL OPERATIONS

### 1. Drive System

#### Play Drive

Direct flywheel drive via flat belt passing around the motor pulley.

Take-up reel driven by an angled belt passing around the motor pulley and a tension pulley.

Note that because the motor and tension pulleys rotate in opposite directions, the belt is also passed around an intermediate pulley.

#### FF and REW Drive

The flywheel driven by a flat belt passing around the motor pulley, presses against an idler which in turn drives the reel bases.

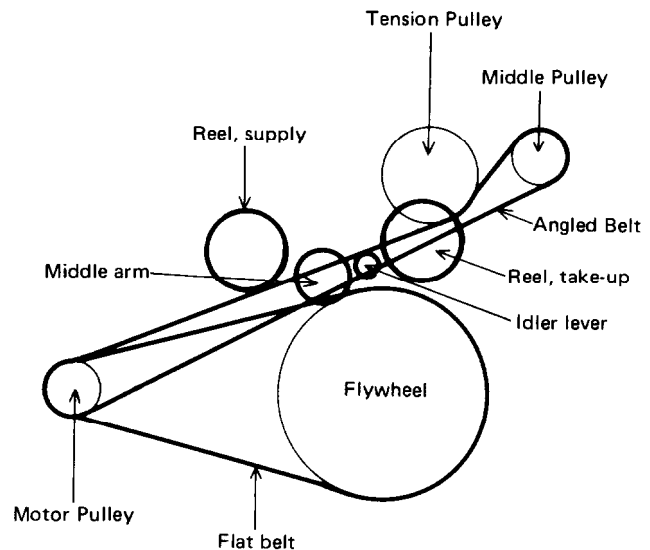

## 2. Auto-Stop

When tape transport stops, the counter pulley driven by a round belt passing over the reel base, and the 12-polar ring magnet connected to the counter pulley, also stop. This is detected by the Hall IC, resulting in the activation of the auto-stop circuit. The solenoid plunger is consequently pulled in, thereby moving the stop plate, and releasing the depressed keys.

## 3. Memory Rewind

When the counter returns to 999 during rewind mode, and the solenoid thereby activated, a pin inserted in the core of the solenoid acts against the stop plate, thereby releasing the depressed key.

The position of this pin is determined by the timer lever. Consequently, only the stop plate is moved.

Although the timer lever is also coupled to the pause key, it will not be moved unless the play key is also depressed. The timer lever is held in check by the selector lever.

## 4. Timer Start

When the record key (and/or play key) and pause key are pressed, the selector lever is moved forwards. And since the timer lever is coupled to the pause key, the pin is moved away from the stop plate, but is in contact with the operation plate. When the power supply is turned on, and the solenoid activated, the operation plate is moved across to the lock plate (which holds the pause key in the pause position), thereby releasing the lock.

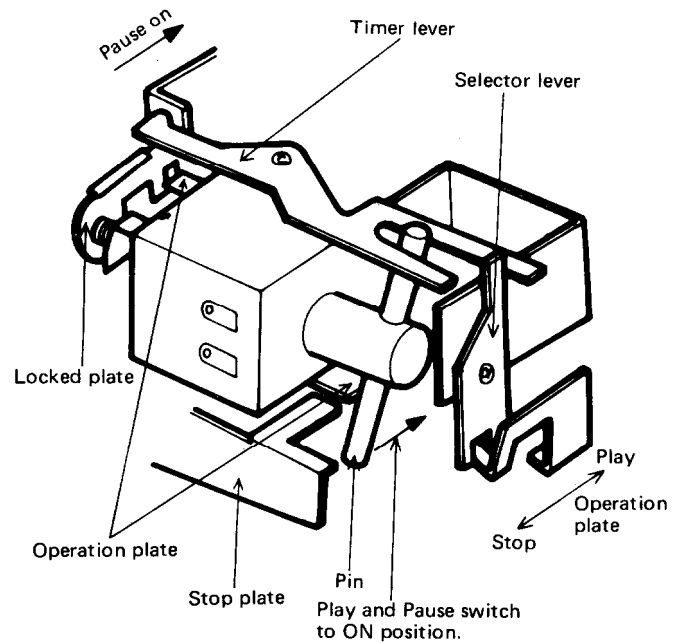

## DISASSEMBLING INSTRUCTIONS

### 1. Removal the cassette door

Press the STOP/EJECT key to open the cassette door, then lift the door up and out to remove as illustrated below.

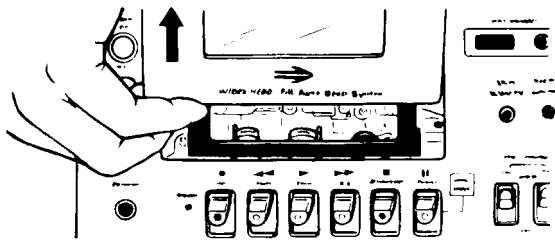

### 2. Removal the front panel

Remove four screws which hold the top cover to side bracket and lift the top cover up. Pull out the input, output and adjust knobs.

Pull out six lever knobs. Remove six screws which hold the front panel to the front bracket.

### 3. Removal the cassette chassis

- (1) Remove the top cover and front panel.
- (2) Remove a screw which hold the shielded plate to deck bracket (L).
- (3) Remove four screws which hold the deck bracket to the front bracket.
- (4) Remove two screws which hold the deck bracket to the top of front bracket.
- (5) Remove the spring from the recording lever (A).

### 4. Replacing the take-up and supply reel

- (1) Remove a screw which hold the door arm (L) to the cassette chassis.
- (2) Remove a screw which hold the door arm (R) to the cassette chassis.
- (3) Remove two spring from the door arm (R).
- (4) Remove the mylar washer to remove the reel.

Note: Once the mylar washer been removed, it cannot be used again. Replace with a new washer.

### 5. Replacing the motor

- (1) Remove two screws which hold the muting switch to motor bracket.
- (2) Remove two belts from the motor pulley and hang to pin.
- (3) Remove two screws (B).



## 6. Replacing the belts

### 6-1. Motor belt (motor pulley—tension pulley)

- 1) Remove two screws (A).
- 2) Remove the belt with a pair of tweezers.

### 6-2. Counter belt

- 1) Remove two screws which hold the auto-stop p.c.b. to counter bracket.
- 2) Remove the belt from the counter pulley.
- 3) Open the cassette door and remove the belt from the take-up reel with a pair of tweezers.

### 6-3. Motor belt (motor pulley—flywheel)

- 1) Remove three screws (C).
- 2) Remove the belt.

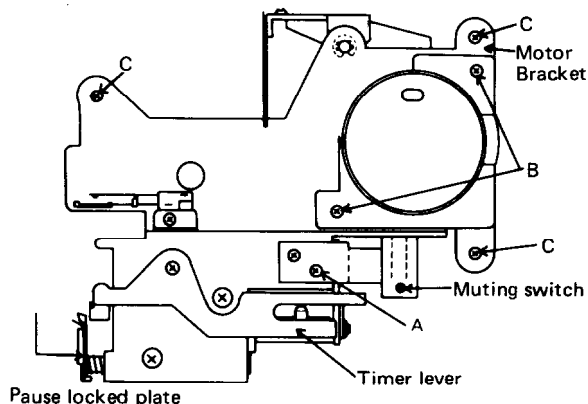

## 7. Replacing the flywheel

- (1) Remove two screws (A).
- (2) Remove two belts from the motor pulley and hang the belt to pin.
- (3) Remove three screws (C).
- (4) Remove the flywheel.

## MECHANISM ADJUSTMENTS

### 1. Door speed adjustment

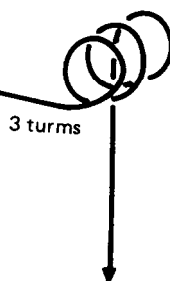
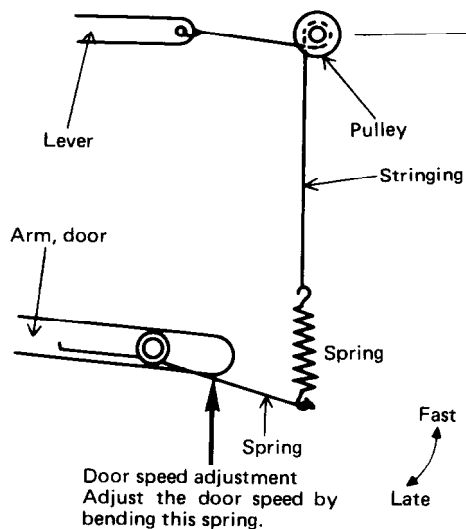

### 2. Play torque adjustment

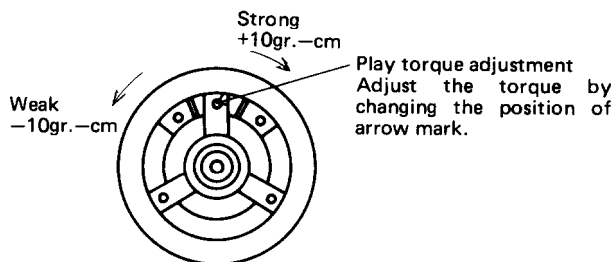

### Current consumption (motor)

Playback:	80 – 120 mA
Recording:	80 – 120 mA
Fast forward:	100 – 180 mA
Rewind:	105 – 180 mA
Auto-Stop	
Playback-Stop:	90 – 110 mA
Rewind-Stop:	280 – 380 mA
F.F.-Stop:	280 – 380 mA

### Mechanism specifications

- 1) Tape speed: 4.8cm/sec. (3kHz +10Hz, -0Hz)  
Use a standard test tape, MTT-111 (3kHz) or equipment.
- 2) Wow and Flutter: Less than 0.055% (WRMS)
- 3) Take-up torque: 35 – 70 gr-cm
- 4) F.F. torque: 55 – 130 gr-cm
- 5) Rewind torque: 55 – 130 gr-cm
- 6) Rewind time: Less than 90 sec. (use a C-60 cassette tape)
- 7) Automatic shut-off time: Less than 5 sec.
- 8) Timer start time: 3.5 sec. – 7 sec.

## ELECTRICAL ADJUSTMENT PROCEDURES

### PRECAUTIONS

#### 1. Tape required:

- (1) Blank tape  
 MAXELL UD-XL/I (Normal)  
 UD-XL/II (CrO<sub>2</sub>)  
 MX (Metal)
- (2) Test tape  
 VICTOR VTT-658 10 kHz, -15 dB  
 TEAC MTT-111 3 kHz, -10 dB  
 MTT-150 Dolby level calibration tone.

#### 2. Instrument required:

- (1) AC VTVM  
 (2) Frequency counter  
 (3) AF oscillator  
 (4) Attenuator

#### 3. The switches and controls should be set as follows unless otherwise specified.

Accu bias adjust control:	Center
Accu bias switch:	Off
Tape selector bias switch:	Normal
Tape selector equalizer switch:	Normal
Dolby NR switch:	Out
Input selector switch:	Line
Output level control:	Maximum
Input level control:	Maximum
FM de-emphasis switch:	25 μsec.

### 1. PLAYBACK MODE ADJUSTMENT

#### 1-1. Head azimuth adjustment

##### PROCEDURES:

- 1) Play the 10 kHz portion of the test tape VTT-658 back. Adjust the head azimuth adjusting screw for maximum V.T.V.M. read.
- 2) If the peak output reads of the right and left channels are different, set the screw to obtain the mechanical center between the peaks.
- 3) After adjustment, lock the screw with bond.

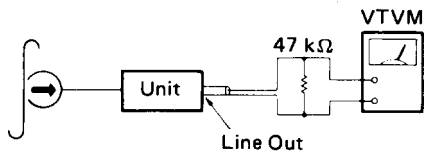

#### 1-2. Tape speed adjustment

##### PROCEDURES:

Play the 3 kHz portion of the test tape MTT-111 back. Adjust the tape speed adjusting semi-fixed resistor in the motor for 3,000 to 3,010 Hz counter indication.

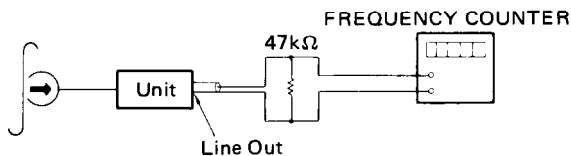

#### 1-3. Playback output adjustment

##### PROCEDURES:

- 1) Play the test tape MTT-150 back, adjust R 135 and R136 for 775 mV V.T.V. M. read.
- 2) Proceed both for the left and right channels in the same manner.

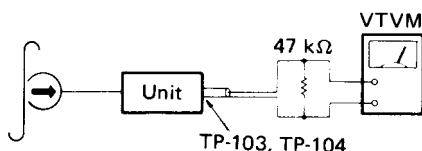

#### 1-4. VU meter adjustment

##### PROCEDURES:

- 1) Play the test tape MTT-150 back.
- 2) Adjust R 243 and R244 until the VU meter pointer deflects to the Dolby mark ( ∞, +3dB) on the meter.

#### 1-5. Playback frequency response adjustment

Connect the AC VTVM to the TP-103 and TP-104 test point. Play the test tape VTT-658 back. Adjust the voltage to 150 mV with R133 and R134.

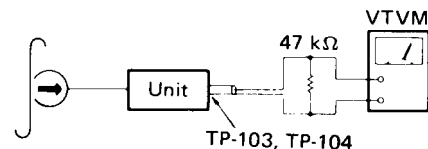

### 2. RECORDING MODE ADJUSTMENT

#### 2-1 Bias trap coil adjustment

- 1) Set the tape deck in the recording mode of operation.
- 2) Set the Bias selector switch to Metal position.
- 3) Connect the AC VTVM to TP-105 and TP-106 test point.
- 4) Adjust L111 and L112 for minimum VTVM read.

**2-2. 19 kHz filter adjustment**

**PROCEDURES:**

- 1) Connect the 19kHz, 1mV input signal to the line in terminal.
- 2) Turn the Dolby NR (MPX Filter) switch to the IN position.
- 3) Connect the VTVM to the MODE terminal.
- 4) Adjust L103, and L104 for minimum VTVM read.

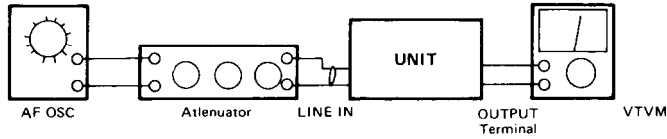

**2-3. Dolby circuit adjustment**

**PROCEDURES:**

- 1) Connect the 5kHz, 10mV input signal to the line in terminal.
- 2) Connect the VTVM to the TP-103 terminal.
- 3) Set the tape deck in the recording mode of operation.
- 4) Adjust the input level volume for 23.5mV VTVM read.
- 5) Turn the Dolby NR (MPX Filter) switch.
- 6) Adjust R167 for 60mV VTVM read.

**2-4. Record bias adjustment**

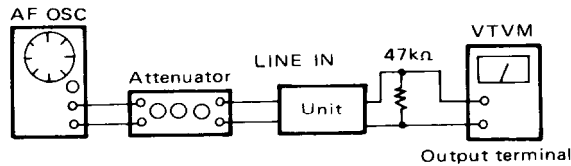

- 1) Press the pause key, and put the tape deck into recording mode. Apply a 400Hz signal to the Line input terminals, and adjust the AF oscillator output so that the VU meter reads 0VU.
- 2) Then set the input level to -20dB, and release the pause switch to record on the tape. Read the output level when this recording is played back again.
- 3) Next change the frequency of the oscillator to 8kHz, and record again as described above. During playback of this recording, obtain the same output level as with the 400Hz recording by readjusting R211 and R212.

**2-5. Record-playback output level adjustment**

**PROCEDURES:**

- 1) Connect the 1kHz input signal to the line in terminal.
- 2) Set the Tape Selector to Normal.
- 3) Connect the VTVM to the output terminal.
- 4) Set the tape deck in the recording mode of operation.
- 5) Adjust the attenuator for 775mV VTVM read.
- 6) Set the deck in the playback mode of operation.
- 7) Adjust the R191 and R192 for 775mV ± 0.5dB VTVM read.

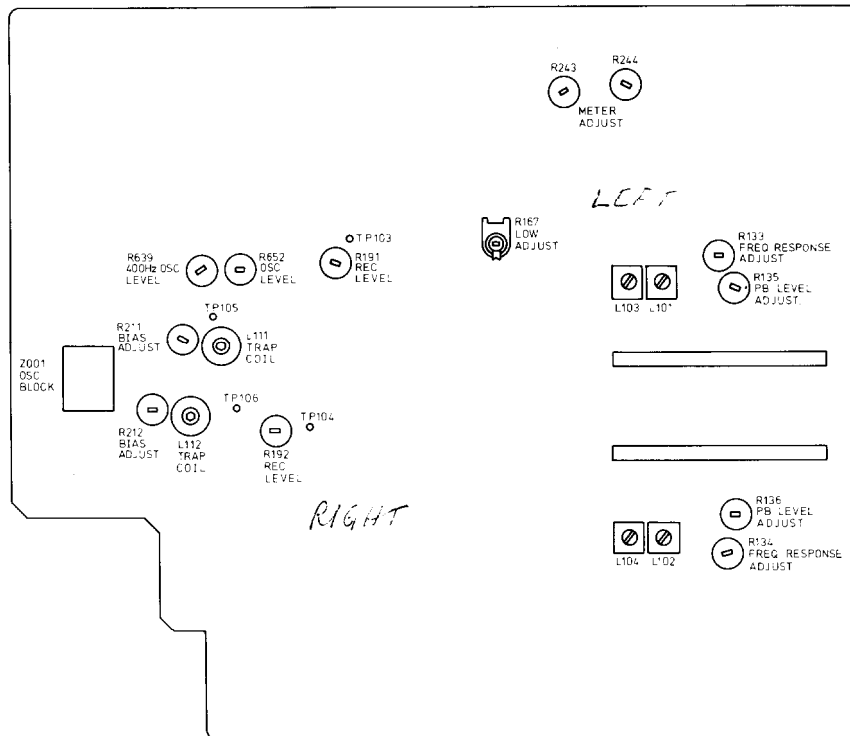
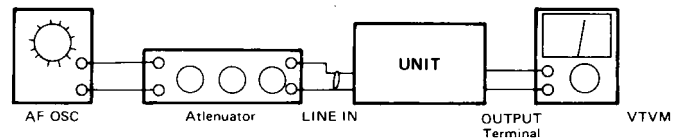

### 3. ACCU. BIAS CIRCUIT ADJUSTMENT

- 1) Set up the tape deck in the recording mode of operation and press the pause key to "ON" position.
- 2) Press the accu. bias switch to "ON" position, and turn the adjusting volume to the center position.
- 3) Connect the AC VTVM to the line output terminal (L channel).
- 4) Adjust the 400Hz and 10kHz oscillator signal to the same level with R639.
- 5) Adjust the line output voltage to 110mV with R652.
- 6) Adjust the VU meter calibration of 400Hz and 10kHz to same manner with R666.
- 7) Adjust the VU meter calibration to the 0 position with R666.

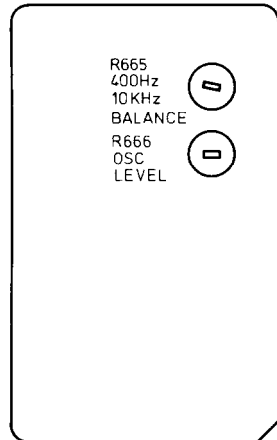

### 4. DOLBY FM LEVEL ADJUSTMENT

- 1) Set the input selector switch to the DOLBY FM.
- 2) Set the de-emphasis selector switch to 25 $\mu$ sec.
- 3) Connect the AF oscillator to the line input terminal and the AC VTVM to the line output terminal.
- 4) Set the AF oscillator to 400Hz, 250mV.
- 5) Adjust the output voltage to 1.1V with R803 and R804 on the back panel.

#### BACK PANEL

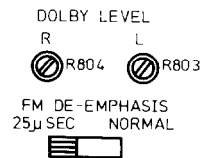

MECHANISM-EXPLODED VIEW

PARTS LIST

REF. NO.	PARTS NO.	DESCRIPTION
1	24610144	Cassette case
2	24603070	Door arm (R)
3	24603071	Door arm (L)
4	24603072	Callor
5	24601026	Pause callor B
6	24605111	Spring
7	24605112	Spring
8	24603073	Locked plate
9	24603074	Callor
10	24603075	Lever, stringing
11	24605089	Spring, tension
12	24610145	Cassette case plate
13	24610146	Holder, counter
14	24601017	Counter
15	24601017	Pulley
16	24610134	1.6 x 4 x 0.2, Mylar washer
17	24610182	Pulley
18	24605113	Spring, tension
19	24606074	NATA-483, Auto stop p.c.b.
20	24610148	Deck chassis
21	24602031	Spindle Reel
22	24605087	Spring, back tension
23	24610149	Holder
24	24610150	Ground terminal
25	24610104	Locked plate
26	24603076	Lever, recording
27	24603077	Lever, rewind
28	24603078	Lever, fast forward
29	24603079	Lever, playback
30	24603080	Lever, stop/eject
31	24605095	Spring
32	24610151	Operation plate
33	24605114	Spring
34	24603081	Operation lever
35	24610152	Brake plate
36	24610153	Stop plate
37	24610154	Stop plate (E)
38	24605105	Spring, stop plate
39		Tube
40	24603082	Lever, pause
41	24603083	Pause plate
42	24603084	Callor
43	24603085	Eject lever
44	24601027	Callor, pause lever
45	24610103	Pinch roller arm ass'y
46	24605115	Spring
47	24610105	Idler lever
48	24604029	Callor
49	24610106	Midle arm
50	24610155	Tension
51	24605097	Spring, tension
52	24610156	Pulley, tension
53	24610157	1.2 x 2.8 x 0.25, Washer
54	24610158	Pin
55	24610159	2.6 x 16, Spacer
56	24610160	Bracket (R)
57	24610161	Bracket (L)
58	24603086	Frame, button
59	24603087	Lever
60	24605116	Spring
61	24605102	Spring
62	24602042	Flywheel
63	24605100	Spring, tension
64	24605101	2.1 x 8 x 0.35, Poly washer
65	24602043	Motor belt (Motor-Flywheel)
66	24605117	Spring, tension
67	24605118	Spring, tension
68	24601025	Pause callor A
69	24605119	Spring
70	24603088	Locked plate
71	24610163	Bracket, motor
72	24603089	Solenoid
73	24605120	Spring, plunger
74	24610164	Operation plate
75	24610165	Terminal
76	24604028	Callor
77	24603090	Lever, timer
78	24603091	Lever, selector
79	24610166	Thru
80	24603092	Lever, recording
81	24605121	Recording plate
82	24601020	Motor with pulley
83	24610167	Plate, motor
84	24601019	Motor pulley
85	24610168	Plate, switch
86	24610169	2.6 x 10.5, Spacer
87	24606075	Slide switch
88	24610170	Switch p.c.b.
89	24610185	Bracket
90	24600009	Rec/Pb head

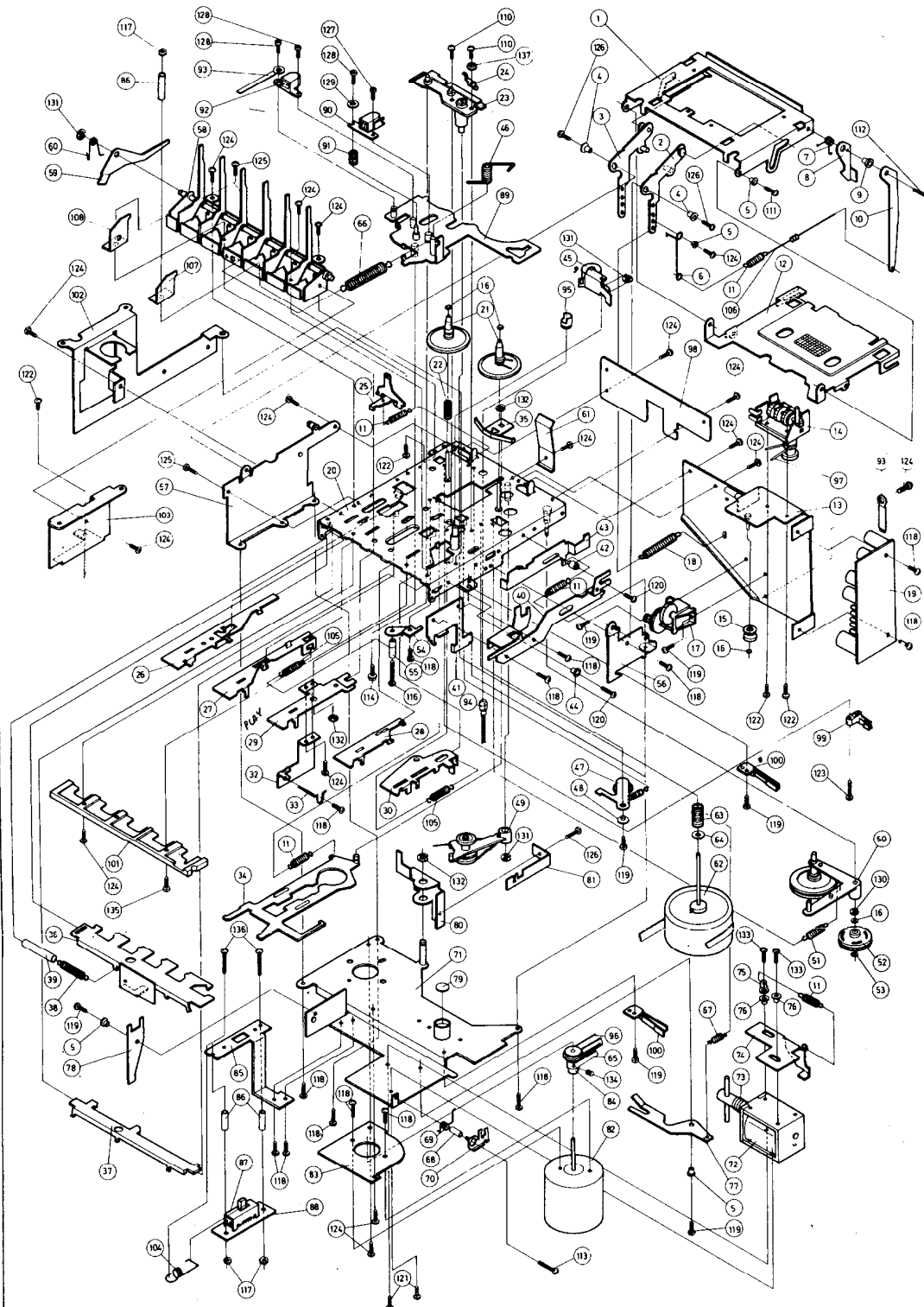

REF. NO.	PARTS NO.	DESCRIPTION
91	24605086	Spring, head azimuth
92	24600015	Erase head
93	24610172	Clamper
94	210043	Pilot lamp
95	24610136	Lamp cushion
96	24602044	Motor belt (Motor-pulley)
97	24602045	Counter belt
98	24610173	Bracket
99	24603093	Leaf switch
100	24603064	Leaf switch
101	24610174	Plate
102	24610175	Side bracket (L)
103	24610176	Side bracket (R)
104	24605122	Spring
105	24605092	Spring, recording lever
106	273903	Stringing
107	24610183	Plate
108	24610184	Plate
110	82142610	2.6 x 10, Pan head screw
111	82542606	2.6 x 6, Binding screw
112	82542608	2.6 x 8, Binding screw
113	801174	2.6 x 8, Pan head screw
114	831126062	2.6 x 6, Tapping screw
115	82112618	2.8 x 18, Pan head screw

REF. NO.	PARTS NO.	DESCRIPTION
116	801175	2.6 x 16, Pan head screw
117	863126	2.6, Hexagone nut
118	801176	2.6 x 4, Pan head screw
119	801177	2.6 x 5, Pan head screw
120	801178	2.6 x 8, Pan head screw
121	801179	3 x 4, Pan head screw
122	801180	3 x 6, Pan head screw
123	82112010	2 x 10, Pan head screw
124	83312605	2.6 x 5, Screw
125	83313005	3 x 5, Screw
126	801181	2.6 x 6, Pan head screw
127	82112004	2 x 4, Pan head screw
128	81112006	2 x 6, Pan head screw
129	8721204505	2Φ, Toothed lock washer
130	893025	E-2.5, Circlip
131	893030	E-3, Circlip
132	893040	E-4, Circlip
133	801182	3 x 5, Pan head screw
134	801183	2 x 4, Screw
135	82112620	M2.6 x 20, Pan head machine screw
136	82112618	M2.6 x 18, Pan head machine screw
137	8711264505	M2.6, Spring washer

TA-630DM1 TA-630DM1

SCHEMATIC DIAGRAM

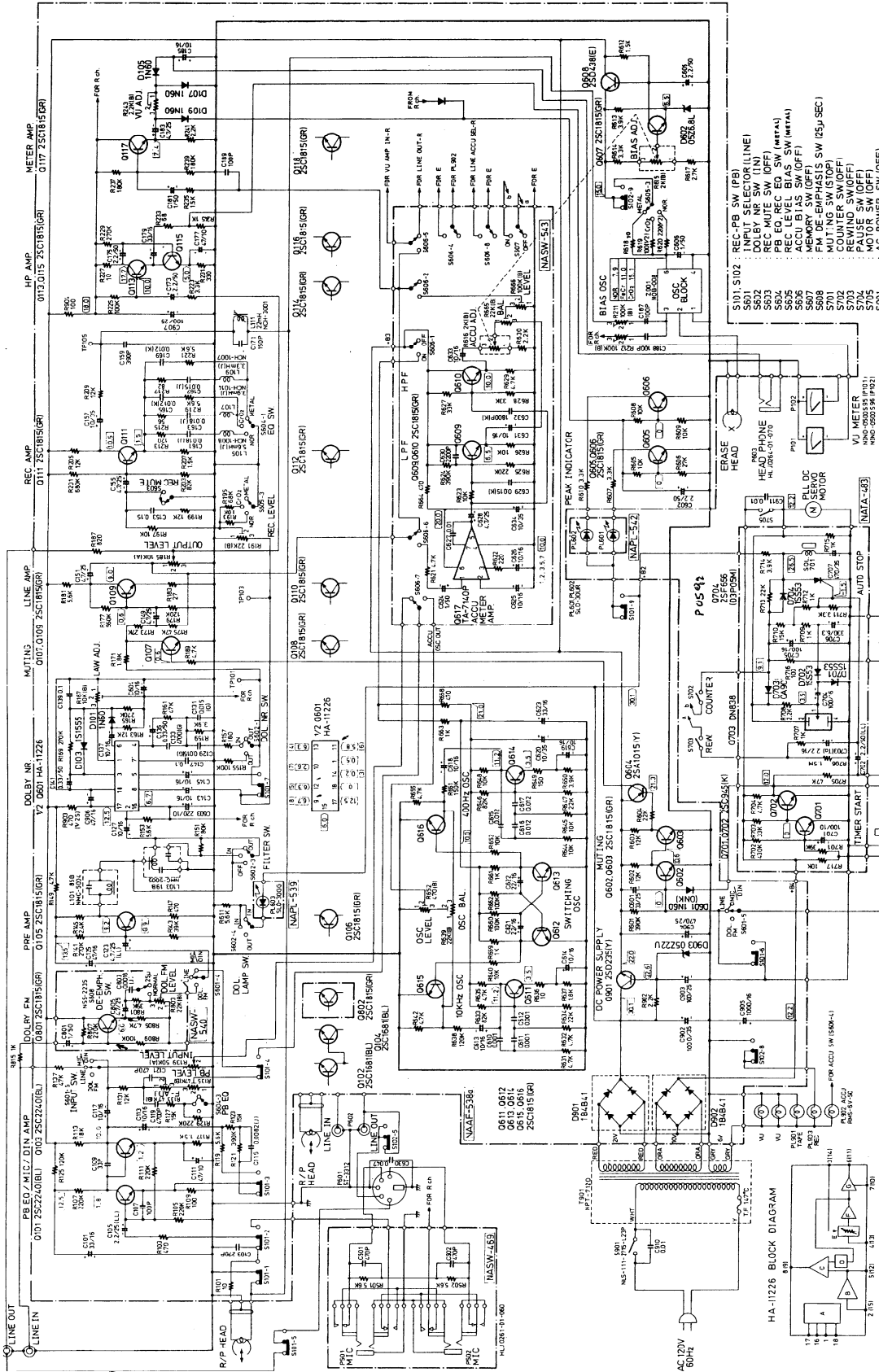

ONKYO CORPORATION

## PARTS LIST

## REC./PB. AMPLI. PC BOARD (NAAF-538a) — PARTS LIST

CIRCUIT NO.	PARTS NO.	DESCRIPTION
<b>TRANSISTORS</b>		
Q101-Q104	2211406	2SC2240 (BL)
Q105-Q118	2211255	2SC1815 (GR)
Q602, Q603	2211255	2SC1815 (GR)
Q604	2211454	2SA1015 (Y)
Q605-Q607	2211255	2SC1815 (GR)
Q608	2211105	2SD438 (E)
Q611-Q616	2211255	2SC1815 (GR)
Q901	2201074	2SD880 (Y)
<b>IC</b>		
Q601	222460	HA-11226, Dolby NR
<b>DIODES</b>		
D101, D102	223103	1N60
D103, D104	223105	1S1555
D105-D110	223103	1N60
D601	2231031	1N60 (N) FM
D602	224044	05Z6.8L
D901, D902	223847	1B4B41
D903	224069	05Z22-U
<b>COILS</b>		
L101, L102	233115	NMC-5004
L103, L104	233116	NMC-5005
L105, L106	24606070	NCH-1008
L107, L108	24606069	NCH-1007
L109, L110	24606080	NCH-1022
L111, L112	24606073	NCH-3011
<b>OSCILLATOR BLOCK</b>		
Z001	24606095	NOB-008
<b>RESISTORS</b>		
R133-R136	5225034	N10HR47KBD, Semi-fixed
R139, R140	5104054	N24RKL50KA30H, Input level
R167	5225017	N10HR10KBC, Semi-fixed
R185, R186	5148020	N16RGM10KA30, Output level
R191, R192	5225032	N10HR22KBD, Semi-fixed
R211, R212	5225016	N10HR100KBD, Semi-fixed
R243, R244	5225005	N10HR2.2KBD, Semi-fixed
R639	5225032	N10HR22KBD, Semi-fixed
R652	5225026	N10HR470BD, Semi-fixed
<b>CAPACITORS</b>		
C101, C102	352743309	33 $\mu$ F, 16V, Elect.
C105, C106	392880227	2.2 $\mu$ F, 50V, LL
C111, C112	352734709	47 $\mu$ F, 10V, Elect.
C113, C114	352741009	10 $\mu$ F, 16V, Elect.
C117, C118	352741009	10 $\mu$ F, 16V, Elect.
C123, C124	392850477	4.7 $\mu$ F, 25V, LL
C125, C126	352744709	47 $\mu$ F, 16V, Elect.
C127, C128	352741009	10 $\mu$ F, 16V, Elect.
C135, C136	392883397	0.33 $\mu$ F, 50V, LL
C137, C138	352741009	10 $\mu$ F, 16V, Elect.
C141, C142	392883397	0.33 $\mu$ F, 50V, LL
C143-C146	352741009	10 $\mu$ F, 16V, Elect.
C149-C152	352750479	4.7 $\mu$ F, 25V, Elect.
C153, C154	374121547	0.15 $\mu$ F $\pm$ 10%, 50V, DE
C155, C156	352750471	4.7 $\mu$ F, 25V, Elect.
C157, C158	352761009	10 $\mu$ F, 35V, Elect.
C173-C176	352780229	2.2 $\mu$ F, 50V, Elect.
C177, C178	352734709	47 $\mu$ F, 10V, Elect.
C179, C180	352743309	33 $\mu$ F, 16V, Elect.
C181, C182	352780109	1 $\mu$ F, 50V, Elect.
C183, C184	352750479	4.7 $\mu$ F, 25V, Elect.
C185, C186	352741009	10 $\mu$ F, 16V, Elect.
C601	352753309	33 $\mu$ F, 25V, Elect.
C602	352780229	2.2 $\mu$ F, 50V, Elect.
C603	352742219	220 $\mu$ F, 16V, Elect.
C604	352741009	10 $\mu$ F, 16V, Elect.
C605	352780229	2.2 $\mu$ F, 50V, Elect.
C606	352780109	1 $\mu$ F, 50V, Elect.
C613, C614	352741009	10 $\mu$ F, 16V, Elect.
C618, C619	352741009	10 $\mu$ F, 16V, Elect.
C620	352761009	10 $\mu$ F, 35V, Elect.

C621, C622	352742209	22 $\mu$ F, 16V, Elect.
C623	352743309	33 $\mu$ F, 16V, Elect.
C902	352761029	1000 $\mu$ F, 35V, Elect.
C903	352751019	100 $\mu$ F, 25V, Elect.
C904	352754711	470 $\mu$ F, 25V, Elect.
C905	352742229	2200 $\mu$ F, 16V, Elect.
C906	352744709	47 $\mu$ F, 16V, Elect.
C907	352751019	100 $\mu$ F, 25V, Elect.
<b>Switches</b>		
S101, S102	25065041	NSS-9234, Rec./Pb. slide
S601	25040043	NLS-163-2715-L19, Input selector lever
S602	25040045	NLS-163-2715-L21, Dolby NR selector lever
S603	25040044	NLS-142-2715-L20, Rec. mute. lever
S604	25040049	NLS-143-2715-L24, Equalizer selector lever
S605	25040049	NLS-143-2715-L24, Bias selector lever

## FM DOLBY PC BOARD (NASW-540)-PARTS LIST

CIRCUIT NO.	PARTS NO.	DESCRIPTION
<b>TRANSISTORS</b>		
Q801, Q802	2211255	2SC1815 (GR)
<b>RESISTORS</b>		
R803, R804	5225101	N10HR22KBD, Semi-fixed
<b>CAPACITORS</b>		
C801, C802	352780101	1 $\mu$ F, 50V, Elect.
C805, C806	352750471	4.7 $\mu$ F, 25V, Elect.
<b>SWITCH</b>		
S608	25065054	NSS-2235, De-emphasis selector

## ACCU INDICATOR PC BOARD (NAPL-539)-PARTS LIST

CIRCUIT NO.	PARTS NO.	DESCRIPTION
PL603	225022	SLD-30GG, L.E.D.

## MIC. CIRCUIT PC BOARD (NASW-469)-PARTS LIST

CIRCUIT NO.	PARTS NO.	DESCRIPTION
P501, P502	25045045	HLJ0261-01-060

## PEAK INDICATOR PC BOARD (NAPL-542)-PARTS LIST

CIRCUIT NO.	PARTS NO.	DESCRIPTION
PL601, PL602	225014	SLD-30UR, L.E.D.

## FILTER CIRCUIT PC BOARD (NASW-543)-PARTS LIST

CIRCUIT NO.	PARTS NO.	DESCRIPTION
<b>TRANSISTORS</b>		
Q609, Q610	2211255	2SC1815 (GR)
<b>IC</b>		
Q617	222454	TA-7140P
<b>RESISTORS</b>		
R665	5225032	N10HR22KBD
R666	5225016	N10HR100KBD
<b>CAPACITORS</b>		
C624	352780101	1 $\mu$ F, 50V, Elect.
C625, C626	352741001	10 $\mu$ F, 16V, Elect.
C628	352750471	4.7 $\mu$ F, 25V, Elect.
C631, C633	352741001	10 $\mu$ F, 16V, Elect.
C634	352761001	10 $\mu$ F, 35V, Elect.
<b>SWITCHES</b>		
S606, S607	25035088-1	NPS-122-182-I.53, Accu & Memory

## PACKING PROCEDURES

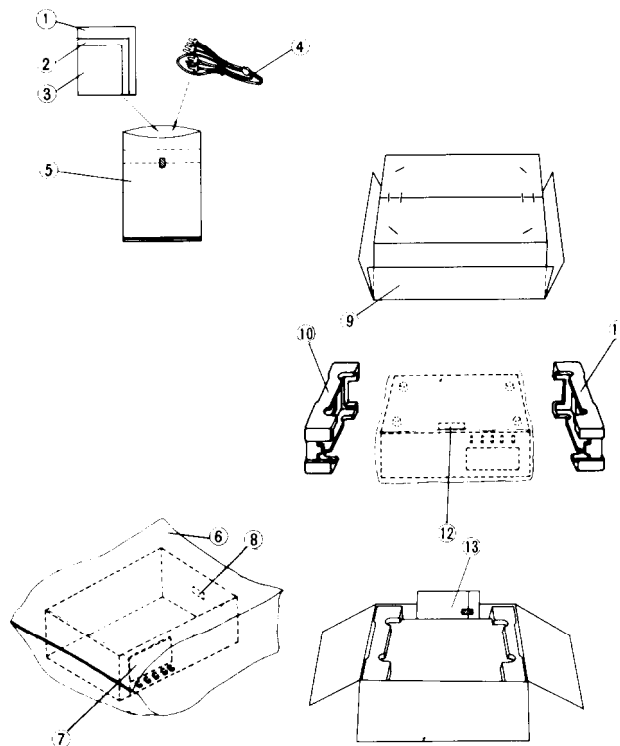

REF. NO.	PARTS NO.	DESCRIPTION
1	29340440	Instruction manual
2	29358002	Service station list
3	29365006	Warranty card
4	253074	Pin-pin connection cord
5	29100005	330 x 220 mm, Poly bag
6	29100037	650 x 500 mm, Poly bag
7	29095079	Protection sheet
8	29360298	Caution label (A)
9	29050184-1	Carton box
10	29090240A	Pad (R)
11	29090357	Pad (L)
12	293041	Caution label
13		Accessory bag complete

**ONKYO CORPORATION**

International Division: No. 24 Mori Bldg., 23-5, 3-chome, Nishi-Shinbashi, Minato-ku, Tokyo, Japan  
 Telex: 2423551 ONKYO J. Phone: 03-432-6981

**ONKYO U.S.A. CORPORATION**

Eastern Office  
 42-07 20th Avenue, Long Island City, New York 11105, U.S.A. Phone: (212) 728-4639  
 Midwest Office  
 935 Sivert Drive, Wooddale, Illinois 60191, U.S.A. Phone: (312) 595-2970