

ONKYO SERVICE MANUAL

STEREO CASSETTE TAPE DECK MODEL TA-R300

Black model

UD,UD [Ⓜ]	120V AC, 60Hz
UG	220V AC, 50Hz
UW	120 or 220V AC, 50/60Hz
UQA, UQB	240V AC, 50Hz

SAFETY-RELATED COMPONENT WARNING!!

COMPONENTS IDENTIFIED BY MARK Δ ON THE SCHEMATIC DIAGRAM AND IN THE PARTS LIST ARE CRITICAL FOR RISK OF FIRE AND ELECTRIC SHOCK. REPLACE THESE COMPONENTS WITH ONKYO PARTS WHOSE PARTS NUMBERS APPEAR AS SHOWN IN THIS MANUAL.

MAKE LEAKAGE-CURRENT OR RESISTANCE MEASUREMENTS TO DETERMINE THAT EXPOSED PARTS ARE ACCEPTABLY INSULATED FROM THE SUPPLY CIRCUIT BEFORE RETURNING THE APPLIANCE TO THE CUSTOMER.

SPECIFICATIONS

Track Format: 4-tracks, 2-channels
Erasing System: AC erase
Tape Speed: 4.8 cm/sec. (1-7/8 i.p.s.)
Wow and Flutter: 0.07% (WRMS)

Frequency Response: 20–17,000Hz (Normal)
(30–16,000Hz \pm 3dB)
20–18,000Hz (High)
(30–17,000Hz \pm 3dB)
20–19,000Hz (Metal)
(30–18,000Hz \pm 3dB)

S/N Ratio: 58dB (metal tape, Dolby NR off)
A noise reduction of 10dB above 5kHz and 5dB at 1kHz is possible with Dolby B NR. A noise reduction of 20dB at 5kHz is possible with Dolby C NR.

Input Jacks: Line IN: 2
Input sensitivity: 60mV
Input impedance: 50kohms

Outputs: Line OUT: 2
Standard output level: 500mV (0dB)
Optimum load impedance: over 50 kohms
Headphone jack: 1
Optimum load impedance: 8 to 200 ohms

Motors: DC servo motor: 1
DC motor: 1

Heads: REC/PB: Special Hard Permalloy x 1;
Erase head: Ferrite x 1

Power Supply Rating: European models:
AC 220V, 50Hz
Canadian models:
AC 120V, 60Hz
Worldwide models:
AC 120V and 220V switchable, 50/60Hz

Power Consumption: 19 watts

Dimensions: 435(W) x 122(H) x 262(D) mm
(17-1/8" x 4-13/16" x 10-15/16")

Weight: 4.5 kg. (9.9 lbs.)

RC-146T Remote Control Transmitter
Transmitter: Infrared
Signal Range: Approx. 5 meters (16 feet)
Power Supply: Two AAA batteries
Dimensions: 38(W) x 150(H) x 15.3(D) mm
(1-1/2" x 5-7/8" x 5/8")
Weight: 62 grams (2.2 oz.) (including batteries)

Specifications and external appearance are subject to change without notice because of product improvements.



SERVICE PROCEDURES

1. Replacement of power supply cord

There are two power supply cord outlets on the strainrelief. Insert them in prescribed direction to ensure safety. AS-UC-3 (UD<120V> model) should be inserted lengthwise and other types of cords should be inserted horizontally.

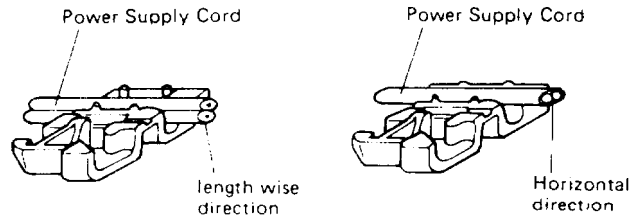

2. Insulating resistance measurement

Connect the insulating-resistance tester between the plug of power supply cord and chassis.

Specifications; 500V more than 10MΩ

HX PRO CIRCUIT OPERATION EXPLANATION

1. Regarding recording frequency characteristic and bias

Ordinarily, if the recording bias current is increased, REC/PB frequency response level in the high frequency region (about 10KHz and above) drops, and if the bias is decreased, the response rises.

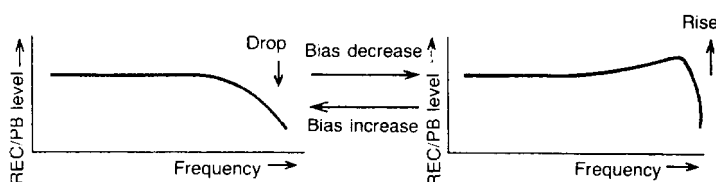

2. Regarding the basic operation of HX PRO (Refer to Fig. 1)

The HX PRO uses the μ PC1297CA IC. The operation is in accordance with the following.

- 1) At (a), the recording bias is added onto the audio signal, and the recording signal is detected. This is the same as the recording head recording the signal on the tape.
- 2) The signal of 1) preserves the frequency response with the integrated circuit of (b).

$$\text{Frequency} = \frac{R433 + R431}{2\pi \times C423 \times R433 \times R431} \quad (2.1)$$

By means of the frequency of Fig. 1, the frequency which is effective from the beginning is determined. In the ordinary situation, this is half the audio band (10KHz), (10KHz ~ 7.5KHz).

- 3) At (c), in order to use the affected waveform after-ward, absolute detection is carried out.

- 4) At (d), the waveform peak value is detected. The output becomes the peak DC voltage.

- 5) At (e), the standard voltage and the voltage of (4) are compared.

- 6) With the output of (e), the frequency generation level is controlled (voltage controlled amplifier). That is, the bias size is varied.

- 7) Summing up 1) ~ 6):

At (a), the time constant (frequency) that is detected in the recording signal is preserved, and above a certain frequency and above a certain level, the VCA controls the bias current by causing its reduction. When this is done, in the manner shown in the explanation of Item 1 above, the frequency high region is raised. With this control, the audio signal is instantaneously dealt with.

3. Regarding the operating conditions of the HX PRO

- 1) With equation (2. 1) noted above, the effect begins at the frequency thus determined.

- 2) Above a certain level the effect begins.

(Substantially 0 dB: In the vicinity of 500mV line out)
The audio signal component level is dependent upon the waveform after point (c).

BLOCK DIAGRAM

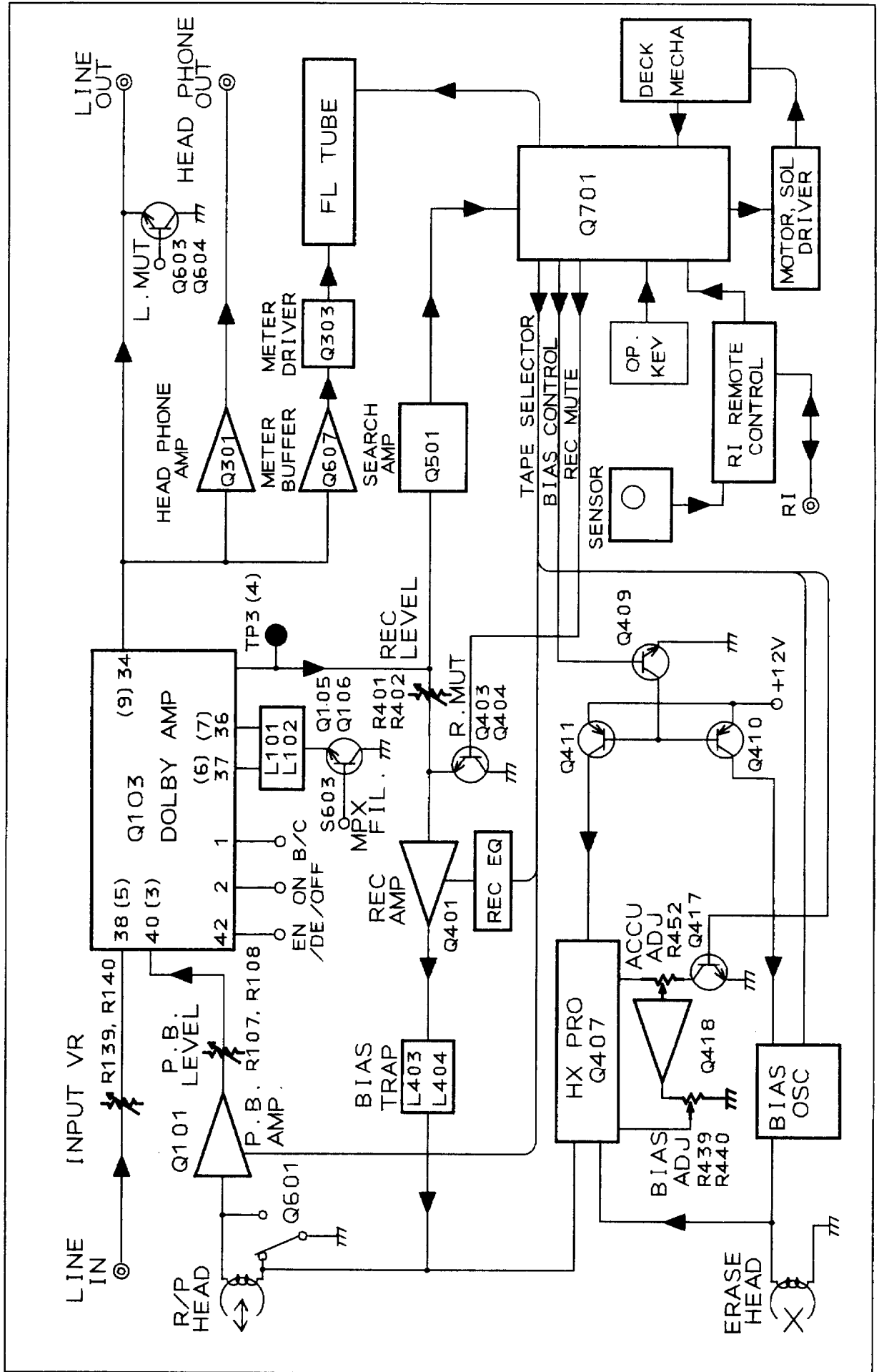

IC BLOCK DIAGRAM

NCHC-3205 (P.B AMP)

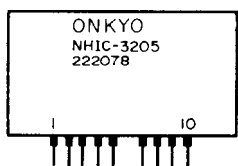
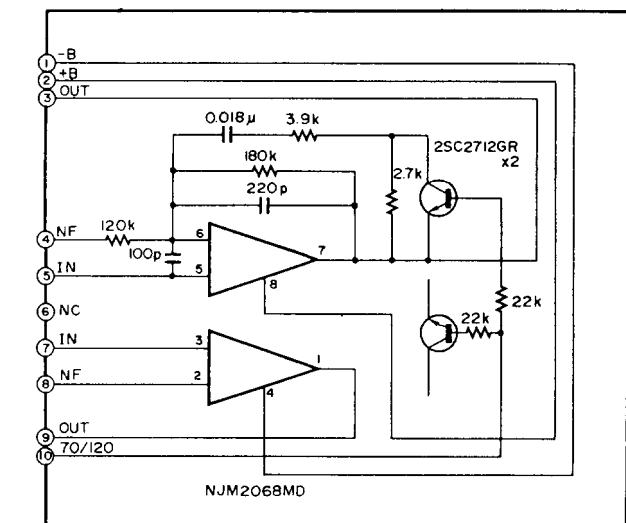

CX20187 (DOLBY N.R)

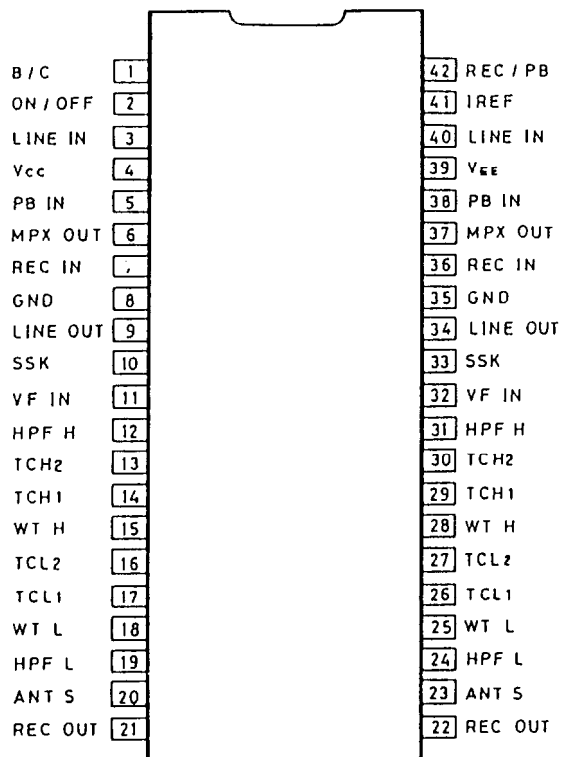

BA6810S (METER DRIVE)

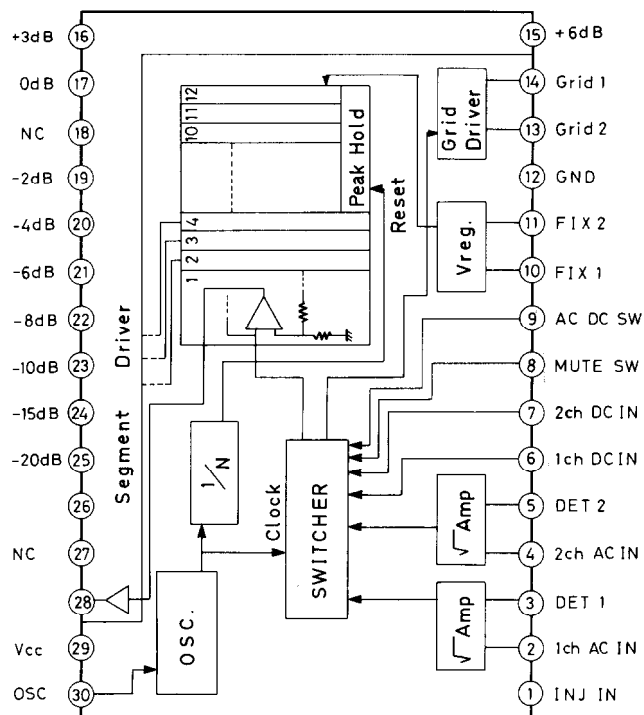

TA-7291S (MOTOR DRIVE)

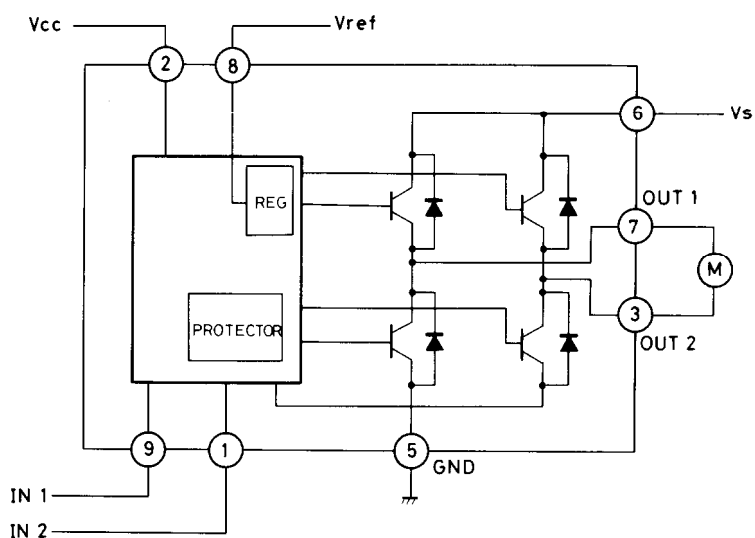



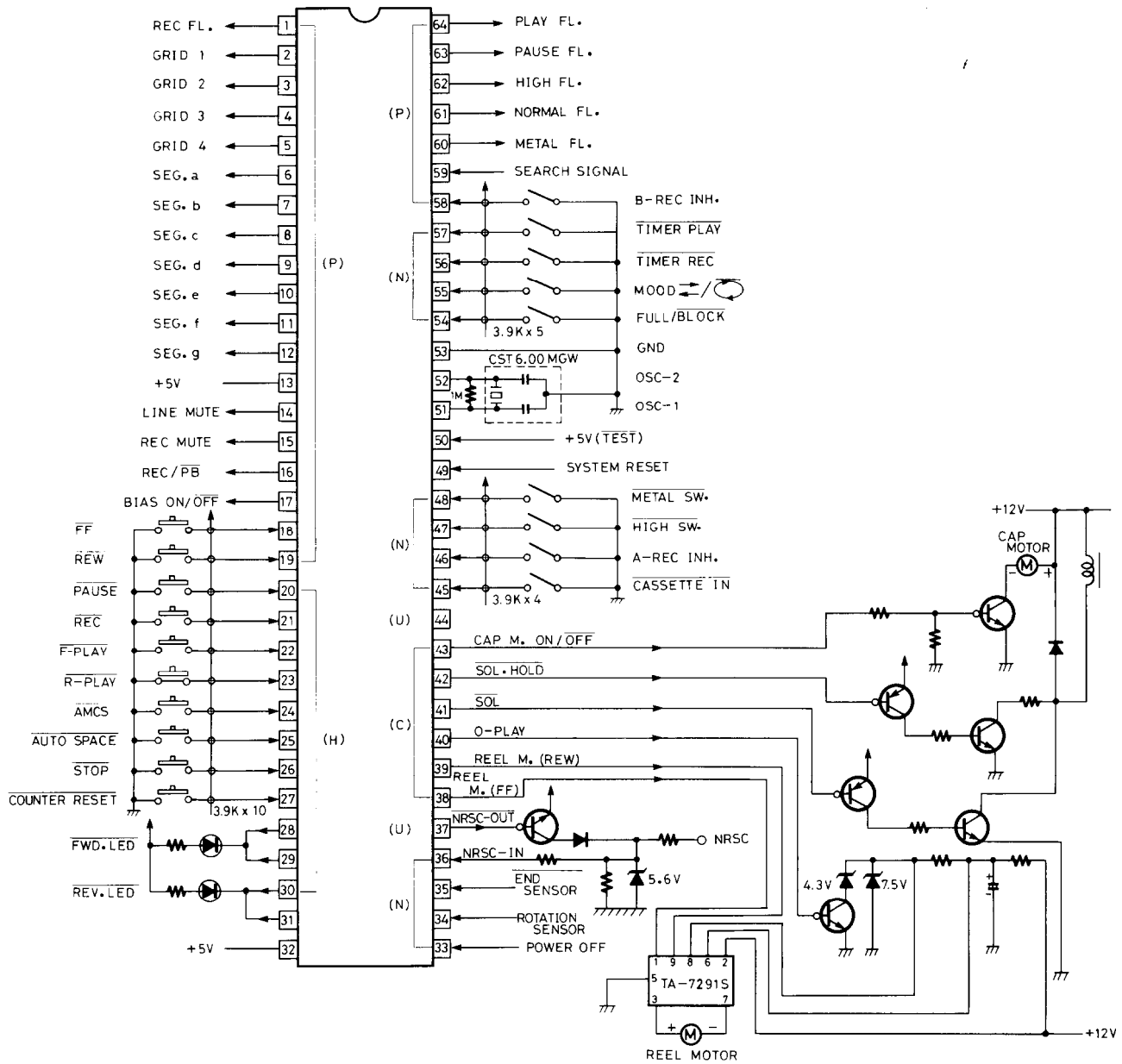

INPUT		OUTPUT		MODE
IN 1	IN 2	OUT 1	OUT 2	
0	0	∞	∞	STOP
1	0	H	L	CW/CCW
0	1	L	H	CCW/CW
1	1	L	L	BRAKE

MICRO COMPUTER (HD614048SJ49)



MICRO COMPUTER

Terminal Name and Function

Pin No.	Name	Function
1	REC FL	Lights up the FL tube REC display. HIGH = Light up.
2 ~ 5	GRID 1 ~ 4	Lights up the FL tube grid 1 ~ 4. HIGH = Light up.
6 ~ 12	SEG. a ~ g	Lights up the FL tube segments a ~ g. HIGH = Light up.
14	LINE MUTE	Line muting output: HIGH = Muting ON/LOW = Muting OFF.
15	REC MUTE	Record muting output: HIGH = Muting ON/LOW = Muting OFF.
16	REC/PB	Record/playback selector output: HIGH = Record/LOW = Playback.
17	BIAS ON/OFF	Recording bias oscillator control output: HIGH = Bias ON/LOW = Bias OFF.
18	FF	FF key input
19	REW	REW key input
20	PAUSE	PAUSE key input: input accepted in STOP, Recording, Playback and Autospace modes.
21	REC	REC key input: effected by simultaneously pressing both PAUSE KEY and PLAY KEY.
22	F-PLAY	F-PLAY key input
23	R-PLAY	R-PLAY key input
24	AMCS	AMCS key input (music selection)
25	AUTO SPACE	AUTOSPACE key input: input accepted from REC and REC/PAUSE modes.
26	STOP	STOP key input
27	COUNTER RESET	COUNTER RESET key input: sets electronic counter to '0000'.
28, 29	FWD.LED	Lights up LED to indicate that the tape is moving in a FORWARD direction. LOW = Light up.
30, 31	REV.LED	Lights up LED to indicate that the tape is moving in the REVERSE direction. LOW = Light up.
32	Vcc	PC power supply.
33	POWER OFF	POWER OFF signal input: HIGH = POWER OFF
34	ROTATION SENSOR	Pulse input for tape counter, tape end sensor and BLOCK REPEAT time.
35	END SENSOR	Input of signal from built-in optical end sensor. LOW = Tape end detected.
38	REEL M. (FF)	Reel motor output (FF direction). Set to HIGH to rotate in FF direction.
39	REEL M. (REW)	Reel motor output (REW direction). Set to HIGH to rotate in REW direction.
40	0-PLAY	Reel motor rotation speed selection output. HIGH = PLAY/LOW = FF/REW.
41	SOL	Triggers the solenoid. LOW = Trigger.
42	SOL.HOLD	Holds solenoid. LOW = Hold.
43	CAP M. ON/OFF	Capstan motor ON/OFF output. HIGH = ON/LOW = OFF.
46, 58	REC INH. (A)	Record inhibit tab (A side) detection input. HIGH = Record inhibit tab broken.
47	HIGH SW.	High position tape detection input. LOW = High position tape.
48	METAL SW.	Metal tape detection input. LOW = Metal tape.
49	RESET	PC system reset.
50	TEST	Link to + Vcc
51, 52	OSC1, OSC2	Internal oscillator input terminal.
53	GND	Grounding
54	BLOCK ON/OFF	BLOCK REPEAT ON/OFF switch input. HIGH = OFF/LOW = ON.
55	MODE  / 	Play tape mode selection switch input. HIGH =  / LOW =  .
56	TIMER REC	Tape selector output. HIGH = OFF/LOW = ON.

Pin No.	Name	Function
57	TIMER PLAY	TIMER PLAY switch. HIGH = OFF/LOW = ON.
59	SEARCH SIGNAL	Signal input for AMCS (music selection). HIGH = Signal detected.
60	METAL FL.	Tape selector input. HIGH output = Metal tape.
61	NORMAL FL.	Tape selector output. HIGH output = No tape or normal tape.
62	HIGH FL.	Tape selector output. HIGH output = High position tape.
63	PAUSE FL.	Lights up FL tube PAUSE display. HIGH = Light up.
64	PLAY FL.	Lights up FL tube PLAY display. HIGH = Light up.

BLOCK REPEAT and AMCS

The BLOCK REPEAT function enables five consecutive plays of the section between any two selected points. The starting point is the point at which the BLOCK REPEAT function is switched ON, or alternatively, if the BLOCK REPEAT function is already switched ON, it is the point during play at which the PLAY button is depressed. If the PLAY button is depressed more than once then the effective starting point will be the last point at which the button was depressed. The return point is the point during F-PLAY at which the REW button is depressed except that if the end of the tape is sensed before the return point has been set then the end of the tape itself will become the return point. The use of the PAUSE or its release during the course of a BLOCK REPEAT will not affect the continuation of the operation but if any other function is activated during the course of a BLOCK REPEAT then this will cause the BLOCK REPEAT function itself to be terminated at that point and the new operation to begin. When the return point is sensed for the fifth time then the BLOCK REPEAT

- * Where the full BLOCK REPEAT section is set to cover too short a period the return point should be moved out until sufficient length has been allowed.

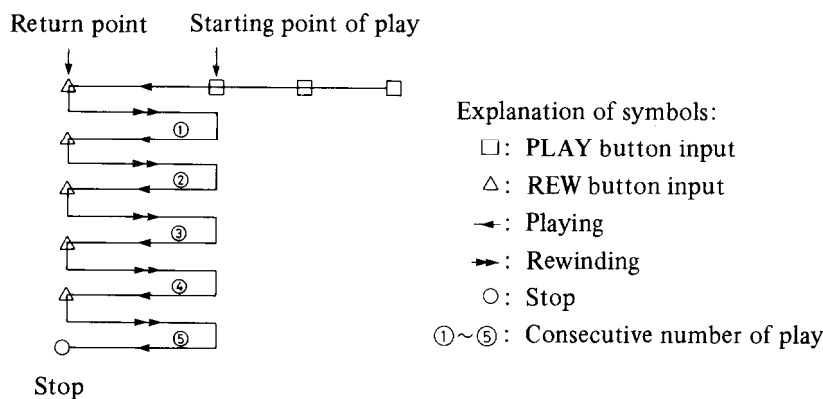

Fig. 2 Representation of BLOCK REPEAT operation

(The play start point and return point are detected by counting the revolution pulses of the reel capstan)

AMCS is a music selection function which operates by putting the mechanism into the CUE condition and then monitoring the signals entering the SEARCH SIGNAL terminal in order to detect the start of the music and then play it for a period of about ten seconds. (Whilst in this play condition the PLAY display flashes at about 1Hz). When the ten seconds is up the machine moves to the next music selection operation.

- * The gap between pieces of music is detected by converting to normal play time and taking a nominal 5 seconds or actual 2.5 seconds or more as the nonrecorded gap.

ADJUSTMENT PROCEDURES

PRECAUTIONS

1. Before adjustment, clean the following parts with an alcohol moistend swab.
 - * record/playback head
 - * pinch roller
 - * erase head
 - * capstan
2. Do not use magnetized screwdriver for adjustments.
3. Demagnetize record/playback head with a head demagnetizer.

TEST EQUIPMENT/TOOLS REQUIRED:

- Audio oscillator
- Digital frequency counter
- Oscilloscope
- Attenuator
- AC voltmeter
- Non-magnetic screw driver
- Test tapes
 - VTT-658 : 10 KHz, -15dB
 - MTT-111 : 3 kHz, -10dB
 - MTT-150 : Dolby level calibration
400Hz, tone 200nWb/m

Item	Connection of instrument	Line input	Test tape	Mode	Output indicator	Adjustment point	Adjust	Remarks	
1	Tape speed	Frequency counter to LINE output terminal	MTT-111	PB	Frequency counter	Semi-fixed on the moter	3000 ± 20Hz		
2	Head azimuth	AC voltmeter and oscilloscope to LINE output terminal	VTT-658	PB	AC voltmeter	Head azimuth screw	Maximum and same phase at channels L and R	Fig.-1	
3	Playback level	AC voltmeter to terminals TP-3 and TP-4	MTT-150	PB	AC voltmeter	R107(Ch.L) R108(Ch.R)	245mV		
4	OSC Block	Frequency counter to P401 read loose coupling	METAL TAPE MX-C60	REC	Frequency counter	L-407	85kHz ± 2kHz		
5	HX-PRO	AC voltmeter to terminals TP-1 and TP-2	METAL TAPE	REC	AC voltmeter	L-405(Ch.L) L-406(Ch.R)	Maximum	R-439 R-440 Max clock wise	
6	Bias current	Fig.-2	1KHz, 20dB and 12kHz, -20dB	XL-II C-90	REC/PB	AC voltmeter	R439(Ch.L) R440(Ch.R)	Same level at REC/PB	Input VR maximum.
7	Record level	Fig-2	1kHz	XL-II C-90	REC	AC voltmeter	Attenuator or AF OSC output	350mV	
					REC/PB	AC voltmeter	R401(Ch.L) R402(Ch.R)	Same level at REC/PB	

Blank tape

NORMAL UD-1 C-90
 HIGH XL-II C-90
 METAL MX C-90

PLAY torque 30 ~ 70 g/cm
 FF.REW torque 80 ~ 180 g/cm
 Back tension 2 ~ 7 g/cm

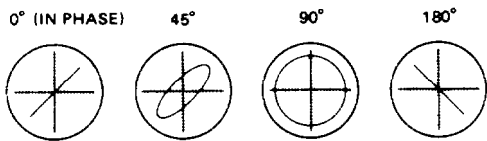
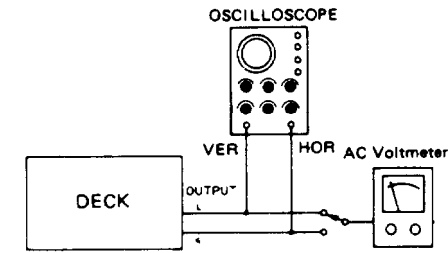
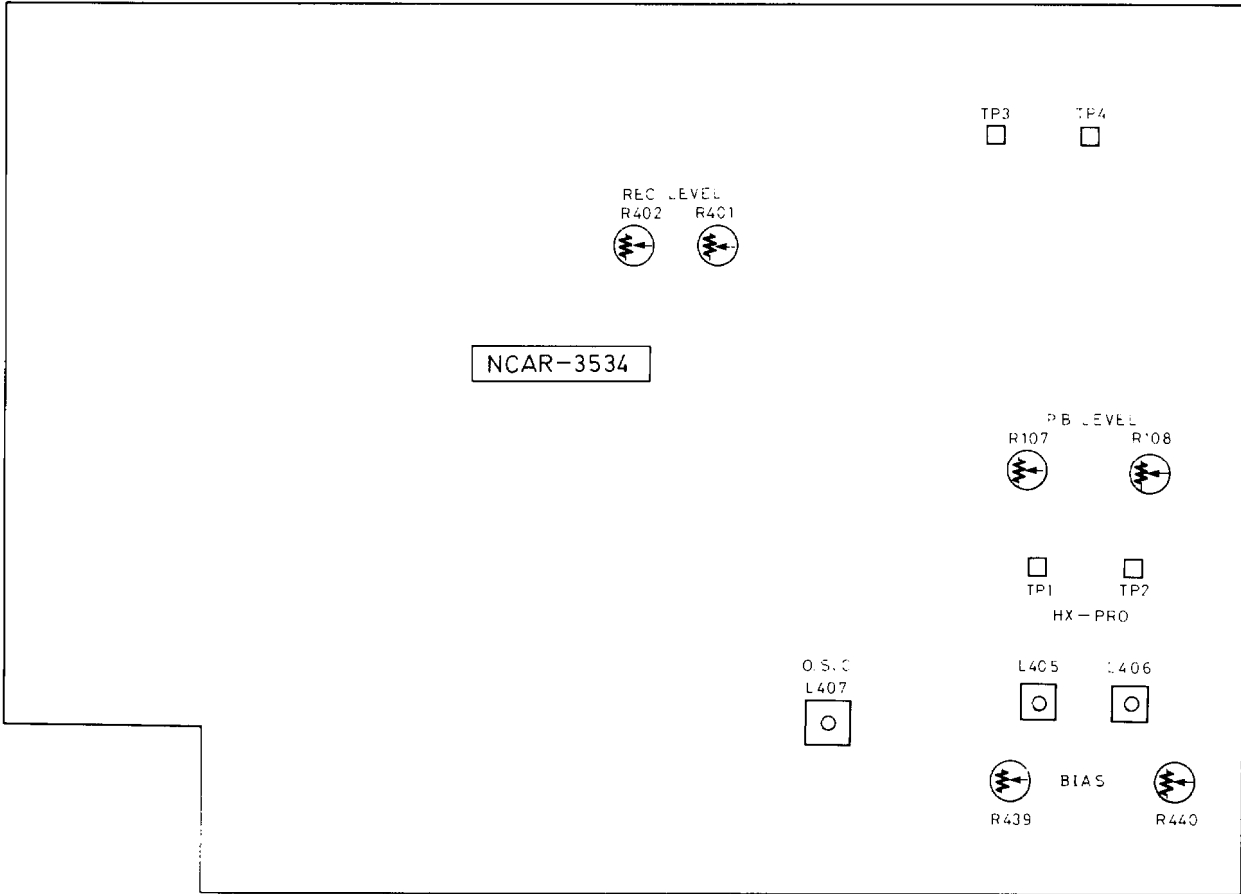

Confirming phase relationship

fig-1

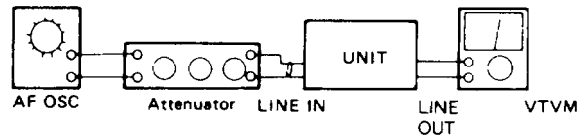

fig-2

CHASSIS-EXPLODED VIEW PARTS LIST

REF.NO.	PART NO.	DESCRIPTION	REF.NO.	PART NO.	DESCRIPTION
A1	27110488	FRONT BRACKET AS	L4	1N065538-2	AETC-3538-2
A3	27100184	CHASSIS	U5	1N065539-2	NASW-3539-2
A4	27190266	HOLDER	L6	1N065540-2	NASW-3540-2
A5	27121253	BACK PANEL (D)	U7	1N065541-2	NASW-3541-2
	27121253-3	BACK PANEL (G)	Z1	244125	CASSETTE DECK MACHANISM, NDM 117
	27121253-2	BACK PANEL (W)			
A6	27300750	BACK PANEL (QA/QB)			
A9	27273069A	BUSHING (CORD)			
A10	27270214A	JOINT (POW)			
A13	28400282	SPACER			
A14	27180315	DAMPER			
A17	28400473	SPRING (T2)			
A17b	27180272	FRAME AS (CASSETTE)			
A18	27130385	SPRING (CA)			
A20	27270142	BRACKET (PT)			
A21	834430088	SPACER			
A22	833430080	TAP-TIGHT SCREW 3TTS + 8B(BC)			
A23	831130088	TAP-TIGHT SCREW 3TTP + 8P(BC)			
A24	834440128	TAP TIGHT SCREW 3TTW + 8B			
A301	28184443Z	TAP TIGHT SCREW 4TTS + 12B(BC)			
A308	28191309A	TOP COVER			
A311	28400482A	CLEAR PLATE			
A311a	28400484	CASSETTE LID AS			
A311b	28400468	CASSETTE LID			
A312	27175152	WINDOW			
A316	834230108	I.F.G AS			
A501	1N065121	TAP-TIGHT SCREW 3TTS + 10B(Ni)			
A801	28323241-1	FRONT PANEL			
A802	28323686A	KNOB (POW)			
A803	28323686A	KNOB AS (EJ)			
A804	28323310	KNOB (PUSH)			
A805	28323696	KNOB (TONE)			
P901	253099C	KNOB (REPEAT)			
	253149	AC CORD, AS-UC 3 (D)			
	253104	AC CORD, AS-CEE (G/W)			
	253118	AC CORD, C2.5BS2 (QB)			
T901	2300424A	AC CORD, AS-SAA (QA)			
	2300425A	NPT-1032D (D)			
	2300426A	NPT-1032G (G)			
	2300427	NPT 1032DG (W)			
S902	25065123	NPT-1032Q (QA/QB)			
U1	1N065534-2	SWITCH NSS 1258P (W)			
U2	1N065535-2	NAAR 3534-2			
U3	1N065537-2	NADIS 3535-2			
		NADIS-3537-2			

NOTE (D) : Only 120V model
 (G) : Only 220V model
 (W) : Only Worldwide model
 (Q) : Only 240V model
 (QB) : Only U.K. model
 (PX) : Only P.X. model

NOTE: THE COMPONENTS IDENTIFIED BY MARK
 ▲ ARE CRITICAL FOR RISK OF FIRE AND
 ELECTRIC SHOCK. REPLACE ONLY WITH
 PARTS NUMBER SPECIFIED.

CHASSIS-EXPLODED VIEW

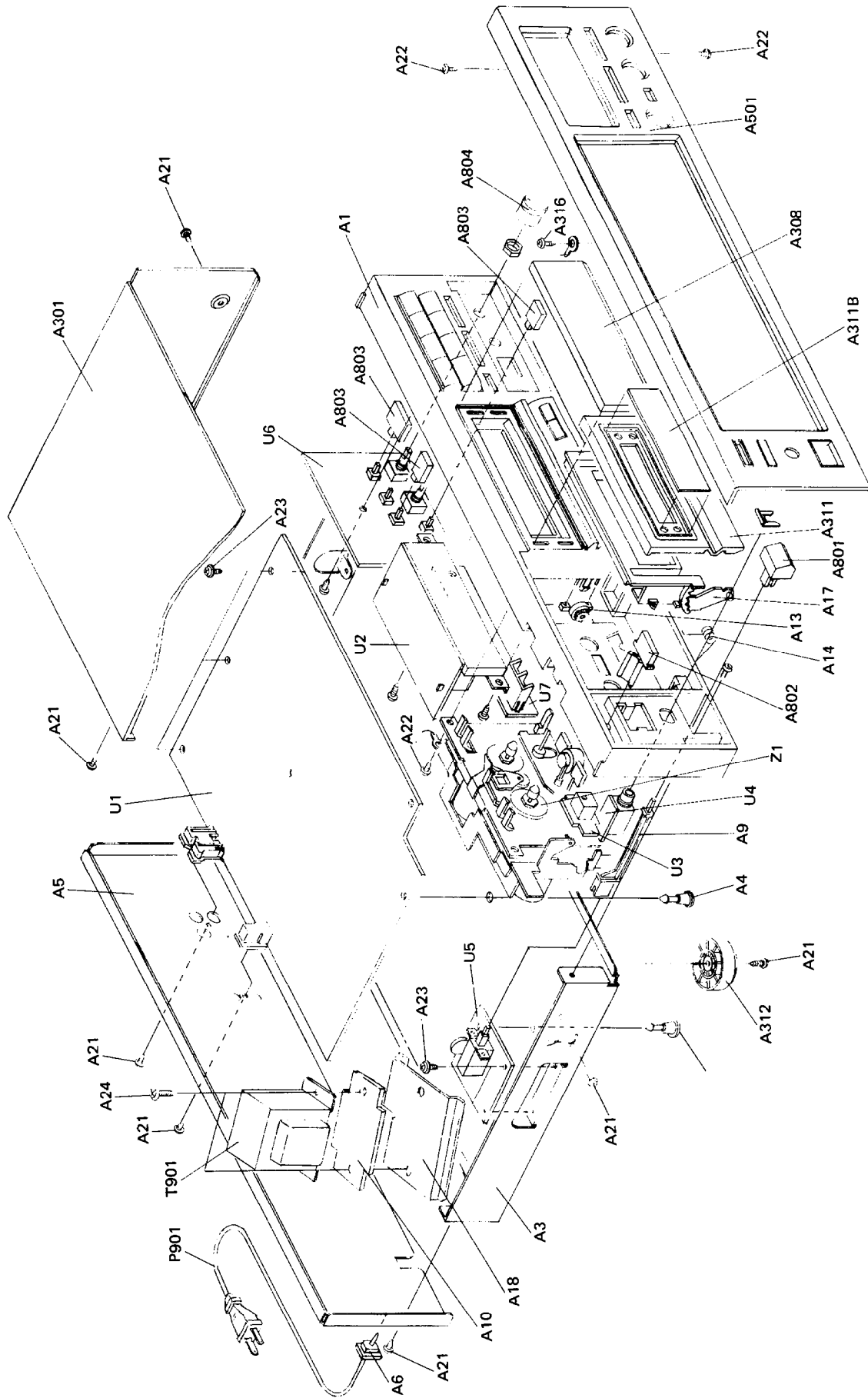

TAPE MECHANISM PARTS LIST

REF.NO.	PART NO.	DESCRIPTION
2	24611381	MECHANISM CHASSIS AS
2-1	24602482	IDLER AS
2-2	24601245	REEL MOTOR
2-3	24611382	BASE AS (CHASSIS)
2-4	24602483	BASE AS (REEL)
2-5	24602484	BASE AS (REEL)
2-6	24606333	SOLENOID COIL AS
2-7	82112606	PAN HEAD SCREW 2.6P - 6F
2-8	24611177	PLASTIC WASHER 1.7 × 3.2 × .25
2-9	24606331	PLANGER
2-11	24611175	PLASTIC WASHER 2.1 × 7 × .25
2-12	24606332	CORE
3-5	24611394	HEAD BASE
3-9	24605711	SPRING
3-10	24600086	R/P HEAD
3-11	833120059	TAPPING SCREW 2 × 5ZN
3-20	24606344	PHOTO REFLECTOR
3-21	24606348	LEAD WIRE
4	24601250	MOTOR AS
5	24606345	P.C.B. AS (CONTROL)
5-4	24606346	P.C.B. (CONTROL)
5-6	24606271	PUSH SWITCH
5-13	24606343	PHOTO REFLECTOR
7	24607041A	ARM (PROTECT) L
9	24611384	SLIDE PLATE
10	24611385	LEAD HOLDER
12	24607101	ARM (PLAY)
14	24602485	CAM GEAR (3R)
15	24603365	LEVER (REC)
16	24603368	LEVER (PACK) L
17	24603367	LEVER (METAL) L
18	24602490	MAIN BELT
20	24611041	PLASTIC WASHER 2.6 × 0.25
23	24610841	PLASTIC WASHER 2.6 × 4.7 × .5
25	24605714	SPRING
26	24605716	SPRING
29	24602487	FLYWHEEL AS
30	24602488	FLYWHEEL AS
31	24602414B	PINCH ROLLER AS
32	24602421B	PINCH ROLLER AS
33	24611387	LABEL
36	24609001	PAN HEAD SCREW SW 2.6 × 5ZN
37	24609006	SCREW
39	8930151	E WASHER 1.5S
61	24611388	HOLD PLATE AS
62	833126049	TAP TIGHT SCREW 2.6TTP + 4C
63	24611188A	WASHER (OIL SEAL)
64	24610844	WASHER 1.9 × 5 × 0.25
65	24611389	HOLD PLATE AS
66	24607103	ARM (EJECT)
67	24609002	PAN HEAD SCREW SW 2 × 4ZN
69	838126080	SCREW 2.6 × 8
71	24611323	LUG
84	24606347	WIRE CONNECTOR (R/P)
116	24611034	REFLECTER

A B C D E F G

TAPE MECHANISM-EXPLODED VIEW

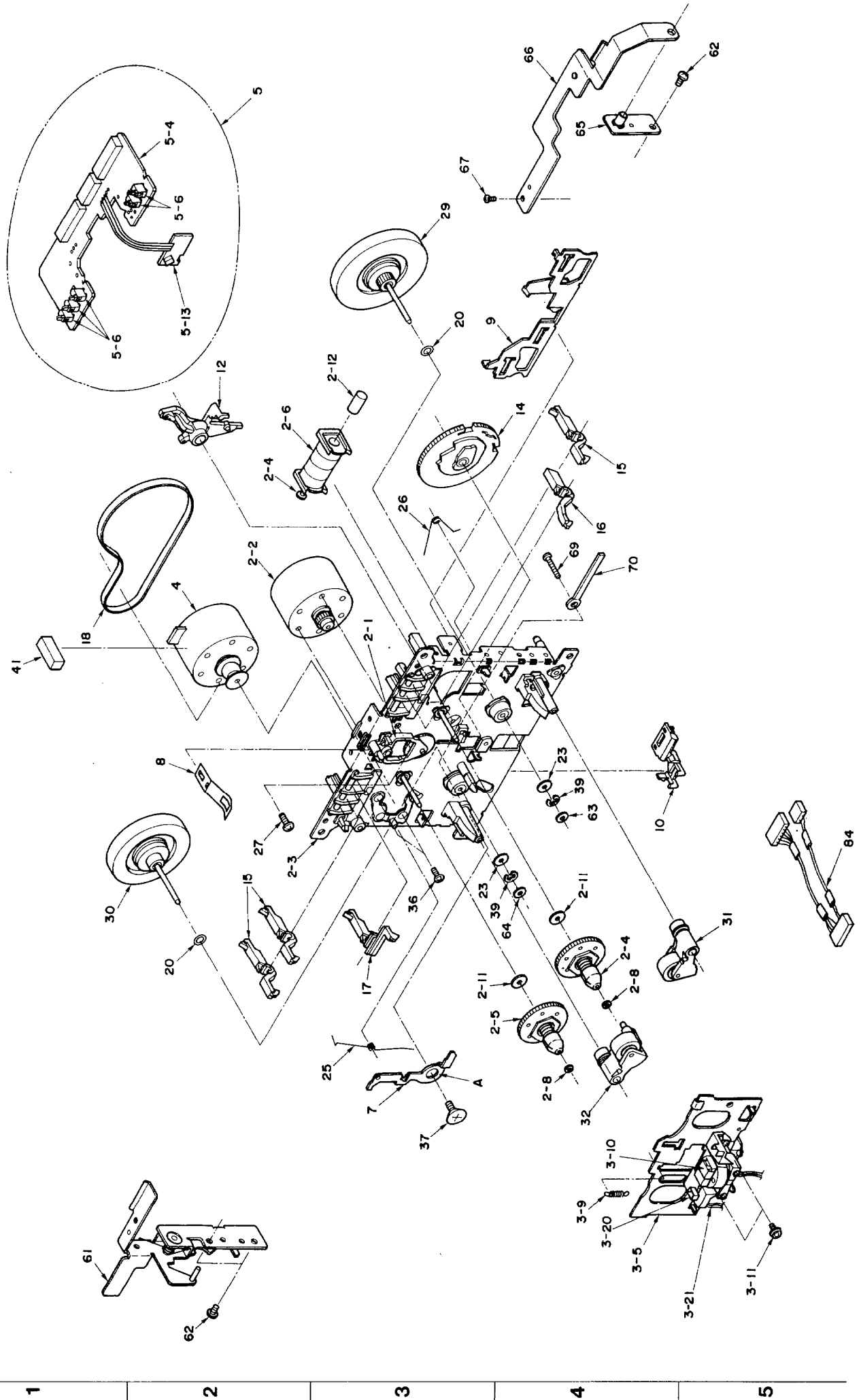

PC BOARD PART LIST

NAAR-3534-2					
CIRCUIT NO.	PART NO.	DESCRIPTION	CIRCUIT NO.	PART NO.	DESCRIPTION
	lcs				
Q101	222078	NHHC 3205	D701	223163	1SS133
Q103	222999	CX 20187	D702	224450433,	MTZ4.3C,
Q301	22240247 or	BA15218N or		224150433 or	05AZ4.3Z or
	222652	M5218L	D703	224650433	HZ4.3EB3
Q401	22240111 or	BA15218 or		224450752,	MTZ7.5B,
	222808	M5218P		224150752 or	05AZ7.5Y or
Q405	22240240	IR2C30	D704-D706	224650752	HZ7.5EB2
Q407	222959	μ PC1297CA	D707	223163	1SS133
Q501	222940	BA335H		224450562,	MTZ5.6B,
Q601	22240147	μ PC1330HA		224150562 or	05AZ5.6Y or
Q418	222465 or	NJM 4558D or	D708,D709	224650562	HZ-5.6E-B2
	222921	BA4558	D901-D906	223163	1SS133
Q607	22240247 or	BA15218N or	D907,D908	223894	1N4002F
	222652	M5218L	D909	223163	1SS133
Q701	22240245	HD614048SJ49		224452001,	MTZ20A,
Q708	22240239	TA-7291S		224152001 or	05AZ20X or
Q713	22240156	LC6527H-3659	D910	224652001	HZ20EB1
Q716	22240248	LC4969		224450511,	MTZ5.1A,
Q901,Q902	222780125 or	78M12 or		224150511 or	05AZ5.1X or
	222780122	78M12	D911	224650511	HZ5.1EB1
Q906	222780055 or	78M05HF or		224451501,	MTZ15C,
	222780052	78M05		224151501 or	05AZ15X or
				224651501	HZ15EB1
	Transistors			Coils	
Q105,Q106	2211255,	2SC1815 GR,	L101,L102	233313	NMC-6048
	2211183 or	2SC1740R or	L103,L104	233382	NMC 2069
	2212485	JC501Q	L401,L402	231084	NCH-2132
Q403,Q404	2211255,	2SC1815 GR,	L403,L404	233314	NCH-2097
	2211183 or	2SC1740R or	L405,L406	231127	NCH-4183
	2212485	JC501Q	L407	231063	NLO 2037
Q409	221281	DTC114YS	X701	3010149	CST6.00MGW
Q410,Q411	2211455	2SA1015 GR	X702	3010150	CST4.00MGW
Q412	2201540	2SD947			
Q413	221281	DTC114YS			
Q414,Q415	2211544	2SC1959-Y	C103,C104	354722219	220 μ F6.3V,ELECT.
Q416,Q417	221281	DTC114YS	C105,C106	354744719	470 μ F16V,ELECT.
Q602	221281	DTC114YS	C109,C110	354742219	220 μ F16V,ELECT.
Q603,Q604	2212794 or	2SD1468-R or	C111-C114	354780229	2.2 μ F50V,ELECT.
	2212795	2SD1468-S	C115,C116	354780479	4.7 μ F50V,ELECT.
Q605	2211455 or	2SA1015-GR or	C123,C124	354784799	0.47 μ F50V,ELECT.
	2212495	JA101Q	C125,C126	354781599	0.15 μ F50V,ELECT.
Q606	221281	DTC114YS	C129,C130	354782299	0.22 μ F50V,ELECT.
Q702	2213090	DTA114YS	C139-C142	354741009	10 μ F16V,ELECT.
Q703	2211455,	2SA1015-GR,	C401,C402	354742209	22 μ F16V,ELECT.
	2213074 or	2SA933 or	C403,C404	354781099	0.1 μ F50V,ELECT.
	2212495	JA101Q	C405,C406	354780479	4.7 μ F50V,ELECT.
Q704	2213090	DTA114YS	C419,C420	354741009	10 μ F16V,ELECT.
Q705,Q706	2211705 or	2SD655-E or	C429,C430	370133314S	330PF100V,APS
	2211706	2SD655-F	C431,C432	370131514S	150PF100V,APS
Q707	2201540	2SD947	C435	354780479	4.7 μ F50V,ELECT.
Q709	221281	DTC114YS	C437	370131234S	0.012 μ F100V,APS
Q710	2211255	2SC1815 GR	C440	3547444709	47 μ F16V,ELECT.
Q711	2211255	2CS1815GR	C441,C442	354721019	100 μ F6.3V,ELECT.
Q712	2213090	DTA114YS	C501	354780229	2.2 μ F50V,ELECT.
Q714,Q715	2213090	DTA114YS	C503	354783399	0.33 μ F50V,ELECT.
Q717	2211255	2SC1815GR	C504	354784799	0.47 μ F50V,ELECT.
Q903	2211455	2SA1015-GR	C505	354741009S	10 μ F16V,ELECT.
Q904	2201924 or	2SD1761 E or	C601	354780109	1 μ F50V,ELECT
	2201925	2SD1761-F	C602,C603	354741009	10 μ F16V,ELECT.
Q905	2211255	2SC1815-GR	C604,C605	354780479	4.7 μ F50V,ELECT.
			C606	354742219	220 μ F16V,ELECT.
			C607	354780479	4.7 μ F50V,ELECT.
D101,D102	224450753,	MTZ7.5C,	C608-C610	354722219	220 μ F6.3V,ELECT.
	224150753 or	05AZ7.5EB3 or	C611	354741009	10 μ F16V,ELECT.
	224650753	HZ7.5EB3	C612	354742219	220 μ F16V,ELECT.
D601-D608	223163	1SS133	C701	354741009	10 μ F16V,ELECT.

SCHEMATIC DIAGRAM(AUDIO SECTION) 1/2

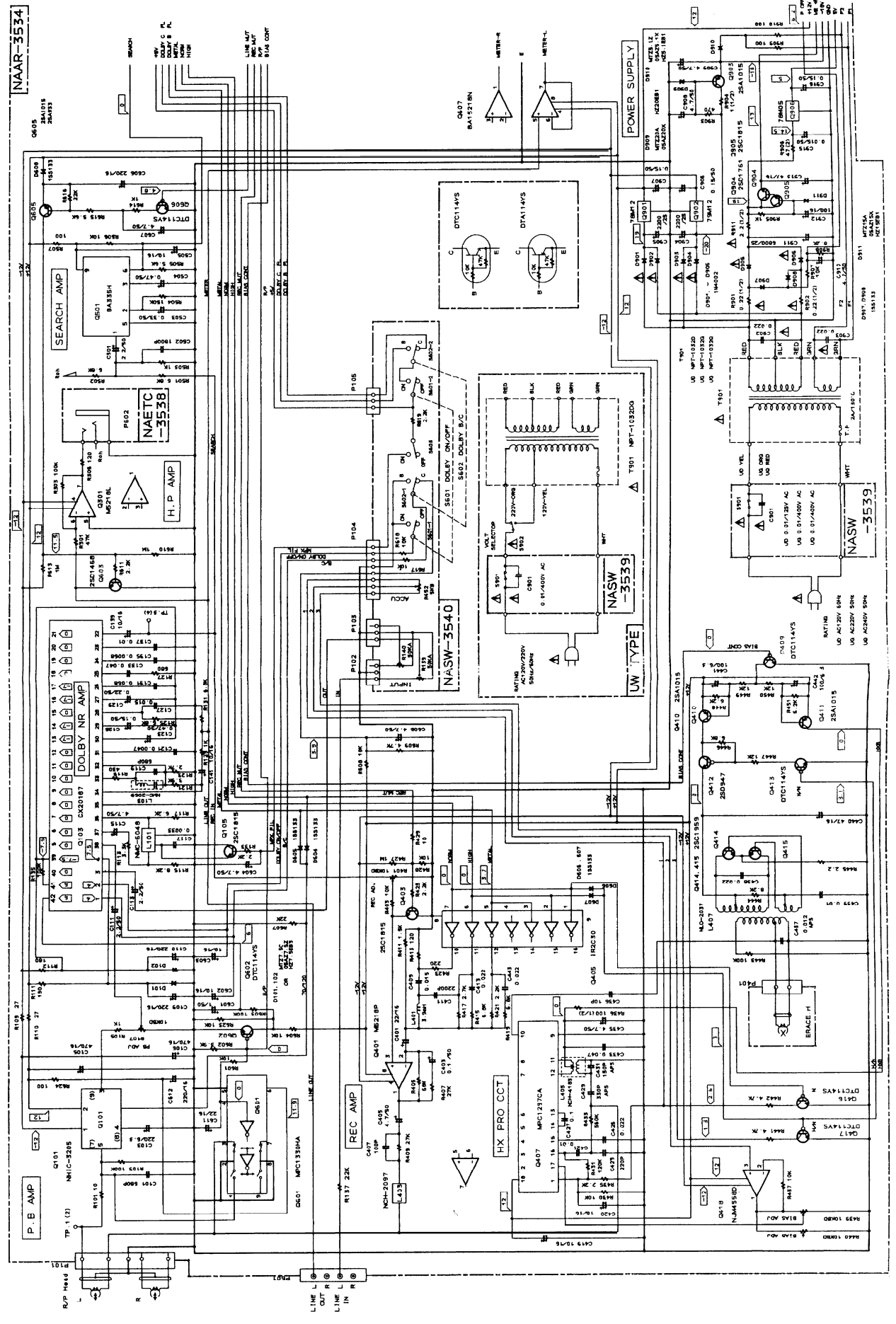

NAAR-3534

NASW-3539

NASW-3540

DTA114VS

DTA114VS

NAETC-3538

P.B. AMP

REC AMP

HX PRO CCT

NASW-3539

UW TYPE

POWER SUPPLY

NASW-3539

UW TYPE

POWER SUPPLY

