

# ONKYO® SERVICE MANUAL

## STEREO CASSETTE TAPE DECK MODEL TA-RW144 / TA-RW244



Black and Silver models

### SPECIFICATIONS

Track Format:	4-track, 2-channels
Erasing System:	AC erase
Tape Speed:	4.8 cm/sec. (1-7/8 i.p.s.) 9.6 cm/sec. (3-3/4 i.p.s.) (high speed dubbing)
Wow and Flutter:	0.08% (WRMS)
Frequency Response:	20 - 15,000 Hz (Normal) (30 - 14,000 Hz $\pm$ 3 dB) 20 - 16,000Hz (High) (30 - 15,000Hz $\pm$ 3 dB) 20 - 17,000Hz (Metal) (30 - 16,000Hz $\pm$ 3 dB)
S/N Ratio:	Dolby NR off: 58dB (metal position tape) A noise reduction of 10dB above 5kHz and 5dB at 1kHz is possible with Dolby B NR. A noise reduction of 20dB at 5kHz is possible with Dolby C NR.
Input Jacks:	Line IN: 2 Input sensitivity: 80mV Input impedance: 50 kohms
Outputs:	Line OUT: 2 Standard output level: 500mV (0dB) Optimum load impedance: over 50 kohms
Motors:	DC servo motor $\times$ 2
Heads:	REC/PB: 1 PB: 1 ERASE: 1
Power Consumption:	17 watts
Dimensions:	435(W) $\times$ 121(H) $\times$ 305(D) mm (17-1/8" $\times$ 4-3/4" $\times$ 12")
Mass:	5.1Kg.(11.2lbs.)

Specifications and external appearance are subject to change without notice because of product improvements.

BMD, BMDN	120V AC, 60HZ
BMP, SMP	230V AC, 50HZ
BMW	120V/220V AC, 50/60Hz

#### SAFETY-RELATED COMPONENT WARNING!!

COMPONENTS IDENTIFIED BY MARK  $\Delta$  ON THE SCHEMATIC DIAGRAM AND IN THE PARTS LIST ARE CRITICAL FOR RISK OF FIRE AND ELECTRIC SHOCK. REPLACE THESE COMPONENTS WITH ONKYO PARTS WHOSE PARTS NUMBERS APPEAR AS SHOWN IN THIS MANUAL.

MAKE LEAKAGE-CURRENT OR RESISTANCE MEASUREMENTS TO DETERMINE THAT EXPOSED PARTS ARE ACCEPTABLY INSULATED FROM THE SUPPLY CIRCUIT BEFORE RETURNING THE APPLIANCE TO THE CUSTOMER.

**ONKYO®**  
**AUDIO COMPONENTS**

# BLOCK DIAGRAM

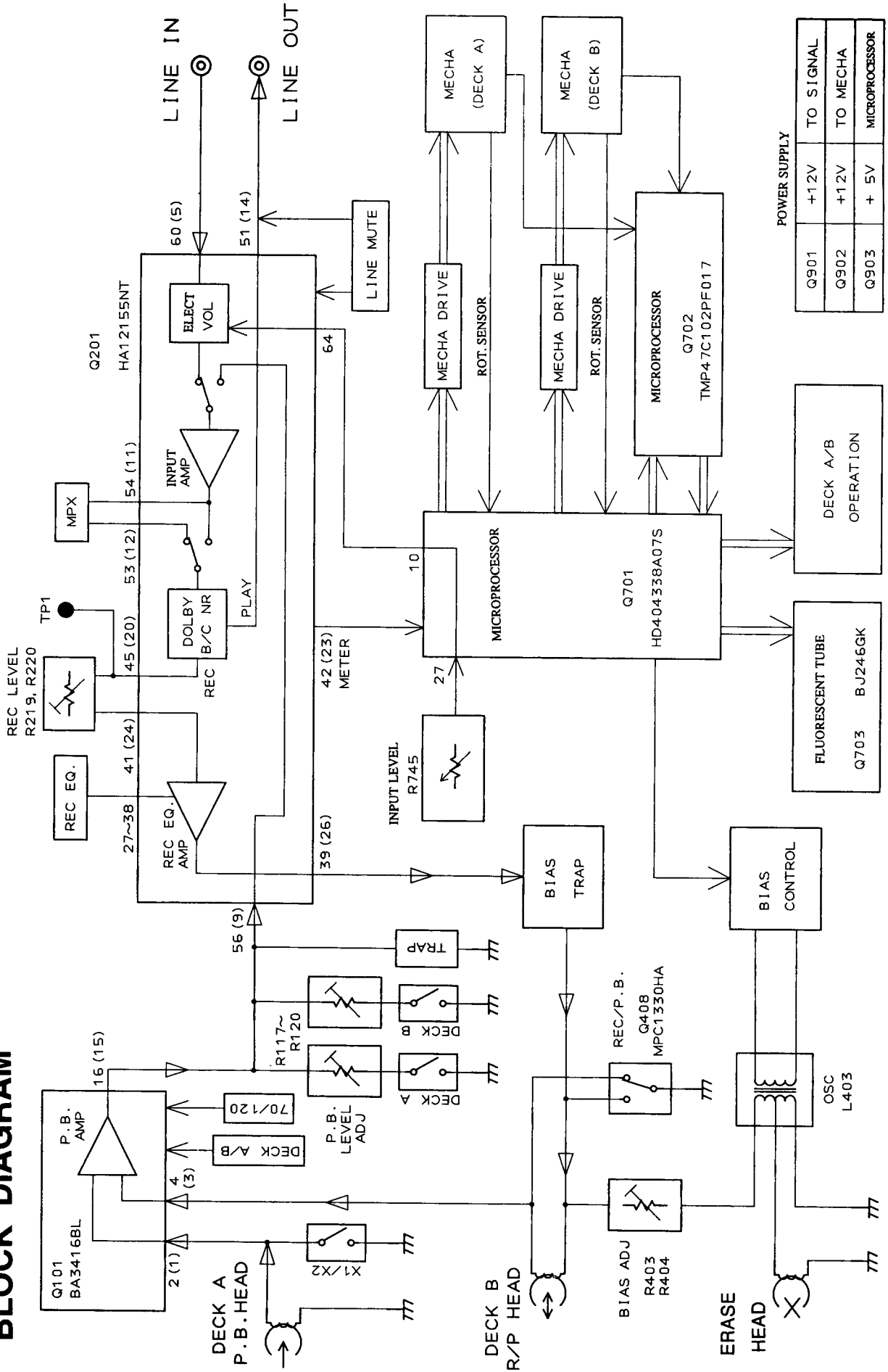

POWER SUPPLY	
Q901	+12V TO SIGNAL
Q902	+12V TO MECHA
Q903	+ 5V MICROPROCESSOR

TA-RW144  
TA-RW244

# CHASSIS - EXPLODED VIEW

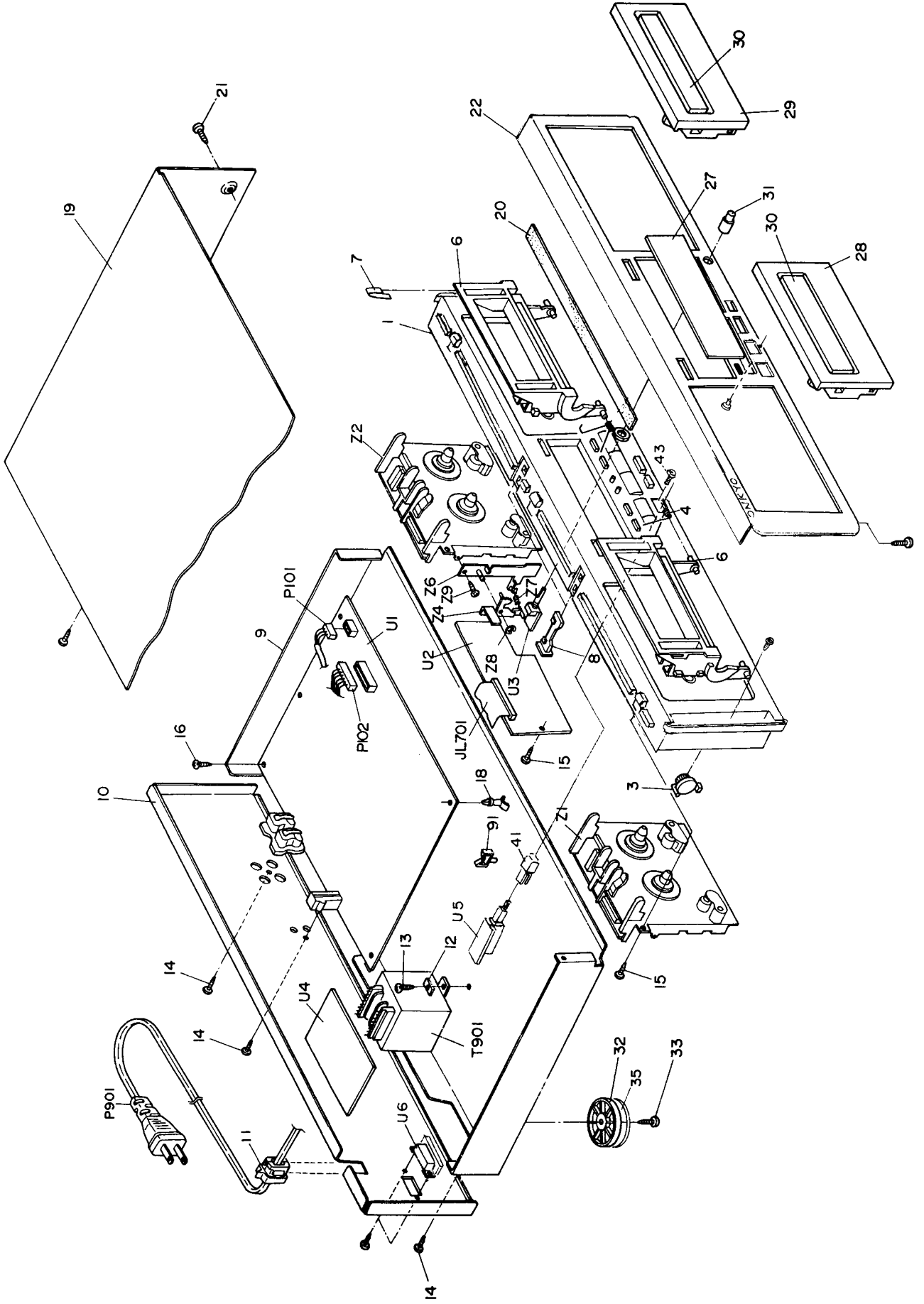

## PARTS LIST

REF. NO.	PART NO.	DESCRIPTION	REF. NO.	PART NO.	DESCRIPTION
1	27110984Y	Front bracket <B>	41	28325489Y	Knob, Power <P/W> <B>
	27110985Y	Front bracket <S>		28325490Y	Knob, Power <S>
3	24611627Y	Damper	42	27141674Y	Retainer, Power <P/W>
4	27180477A	Spring A	43	838430107	3TTB+10S(BC), Self-tapping screw
6	27301792AY	Cassette frame	91	27300833	WS-2NS,Clamp
7	27180435Y	Spring	JL701	2047292512Y	NCFC7-292512,Flexible flat cord
8	28324943Y	Knob, eject <B>	P101	2009990312Y	NSAS-6P0446,Socket
	28325061Y	Knob, eject <S>	P102	2009990313Y	NSAS-14P0447,Socket
9	27100322AY	Chassis	P901	253192HIT	▲ AS-UC-6 #18,Power supply cord <D>
10	27122306Y	Rear panel <D>		253193HIT	▲ AS-CEE,Power supply cord <P/W>
	27122307Y	Rear panel <P/A>		253197HIT	▲ AS-SAA,Power supply cord <A>
	27122309Y	Rear panel <W>	S901	25065123	▲ NSS-1258P,Voltage selector switch <W>
11	27300750	▲ Cord bushing	T901	2301008Y	▲ NPT-1206D,Power transformer <D>
12	870065	Flat washer		2301009Y	▲ NPT-1206P,Power transformer <P/A>
13	830440089	4TTC+8C(BC), Self-tapping screw		2301010Y	▲ NPT-1206DG,Power transformer <W/K>
14	838130088	3TTB+8B, Self-tapping screw	U1	1N266576-4AY	NAAR-4976-4A,Main circuit pc board ass'y <D>
15	838130088	3TTB+8B, Self-tapping screw		1N266576-4BY	NAAR-4976-4B,Main circuit pc board ass'y <P>
16	838130088	3TTB+8B, Self-tapping screw		1N266576-4CY	NAAR-4976-4C,Main circuit pc board ass'y <W>
17	835430068	3TTF+6B(BC), Self-tapping screw	U2	1N266577-4AY	NADIS-4977-4A,Display circuit pc board ass'y <D>
18	27190480-1Y	PCB-8L,Holder		1N266577-4BY	NADIS-4977-4B,Display circuit pc board ass'y <P>
19	28184664Y	Top cover <B>		1N266577-4CY	NADIS-4977-4C,Display circuit pc board ass'y <W>
	28184669Y	Top cover <S>	U3	1N266578-4AY	NAAF-4978-4A,Input volume pc board ass'y <D>
20	28141332	Cushion <244>		1N266578-4BY	NAAF-4978-4B,Input volume pc board ass'y <P>
21	838430088	3TTB+8B(BC), Self-tapping screw <B>		1N266578-4CY	NAAF-4978-4C,Input volume pc board ass'y <W>
	838230088	3TTB+8B(NI), Self-tapping screw <S>	U4	1N266580-4AY	NAPS-4980-4A,Power supply pc board ass'y <D>
22	27211893Y	Front panel <144>		1N266580-4BY	NAPS-4980-4B,Power supply pc board ass'y <P>
	27211894Y	Front panel <244B>		1N266580-4CY	NAPS-4980-4C,Power supply pc board ass'y <W>
	27211897Y	Front panel <244S>	U5	1N209504-4BY	NASW-6004-4B,Power switch pc board ass'y <P>
25	28198859Y	Facet		1N209504-4CY	NASW-6004-4C,Power switch pc board ass'y <W>
26	28135244Y	Badge <B>	U6	1N209505-4CY	NASW-6005-4C,Voltage selector switch pc board ass'y <W>
	28135245Y	Badge <S>	Z1	244186A	NDM-177,Deck mechanism A
27	28191771Y	Clear plate <B>	Z2	244187B	NDM-178,Deck mechanism B
	28191772Y	Clear plate <S>	Z3	24603402AY	Lever L, eject
28	27301853Y	Cassette lid A <B>	Z4	24603404AY	Lever R, eject
	27301857Y	Cassette lid A <S>	Z5	24611591AY	Retainer L
29	27301853-1Y	Cassette lid B <B>	Z6	24611593AY	Retainer R
	27301857-1Y	Cassette lid B <S>	Z7	24605798Y	Spring
30	28400625	Window <B>	Z8	8930301	Ring E
	27301858Y	Window <S>	Z9	833126047	2.6TTP+4S,Self-tapping screw
31	28323671A	Knob, volume <B>			
	28325060	Knob, volume <S>			
32	27175316B	Leg			
33	838130088	3TTB+8B, Self-tapping screw			
34	838130088	3TTB+8B, Self-tapping screw			
35	28141332Y	Cushion for leg			

NOTE: <D>:120 V model only  
<P>:230 V model only  
<W>:Worldwide model only  
<144>:Model TA-RW144 only  
<244>: Model TA-RW244 only  
<A>:Australian model only  
<B>:Black model only  
<S>:Silver model only

NOTE: THE COMPONENTS IDENTIFIED BY MARK ▲  
ARE CRITICAL FOR RISK OF FIRE AND  
ELECTRIC SHOCK. REPLACE ONLY WITH  
PART NUMBER SPECIFIED.

## ADJUSTMENT PROCEDURES

### PRECAUTIONS

1. Before adjustment, clean the following parts with an alcohol moistend swab.

- \* record/playback head
- \* erase head
- \* pinch roller
- \* capstan

2. Do not use magnetized screwdriver for adjustments.

3. Demagnetize record/playback head with a lead demagnetizer.

### TEST EQUIPMENT/TOOLS REQUIRED:

- Audio oscillator
- Digital frequency counter
- Oscilloscope
- Attenuator
- AC voltmeter
- Non-magnetic screwdriver
- Test tapes
  - TCC-153 :10kHz, -15dB
  - MTT-111 :3kHz, -10dB
  - MTT-150 :Dolby level calibration  
400Hz, tone 200nWb/m

### Tape speed adjustment

Connect the digital frequency counter to the line output terminal.

Load the test tape MTT-111 into the cassette holder.

Connect the test point TP-2 to the ground to be the unit to adjustment mode.

Press the forward play button. (The unit becomes the high speed.)

Adjust the trim resistors R802(Deck A) and R817(Deck B) so that the frequency counter reading becomes 6000Hz to 6020Hz

Press the forward play button. (The unit becomes the normal speed.)

Adjust the trim resistors R803(Deck A) and R818(Deck B) so that the frequency counter reading becomes 3000Hz to 3010Hz

Item	Connection of instrument	Line input	Test tape	Mode	Output indicator	Adjustment point	Adjust	Remarks	
1	Head azimuth		TCC-153	PB	AC voltmeter Oscilloscope	Head azimuth screw	Maximum and same phase at channels L and R	fig-1	
2	Playback level		MTT-150	PB	AC voltmeter	DECK A R117 (ch. L) R118 (ch. R) DECK B R119 (ch. L) R120 (ch. R)	300mV		
3	Bias frequency		METAL TAPE XS-C90	REC	Frequency counter	L403	85kHz±2kHz		
4	Bias current	fig-2	1kHz, -23dB and 12kHz, -23dB	UD-1 C-90	REC/PB	AC voltmeter	R403 (ch. L) R404 (ch. R)	Same level at 1kHz and 12kHz	Repeat the recording and play back until the 1kHz and 12kHz playback signals are same level.
5	Record level	fig-2	1kHz	UD-1 C-90	REC	AC voltmeter	Attenuator or AF OSC output	350mV	
					REC/PB	AC voltmeter	R219 (ch. L) R220 (ch. R)	Same level at REC/PB	

Blank tape NORMAL .....UD-1 C-90  
HIGH .....XL-II C-90  
METAL.....XS C-60

PLAY torque.....30~70g/cm  
FF. REW torque .....80~180g/cm  
Back tention .....6~12g/cm

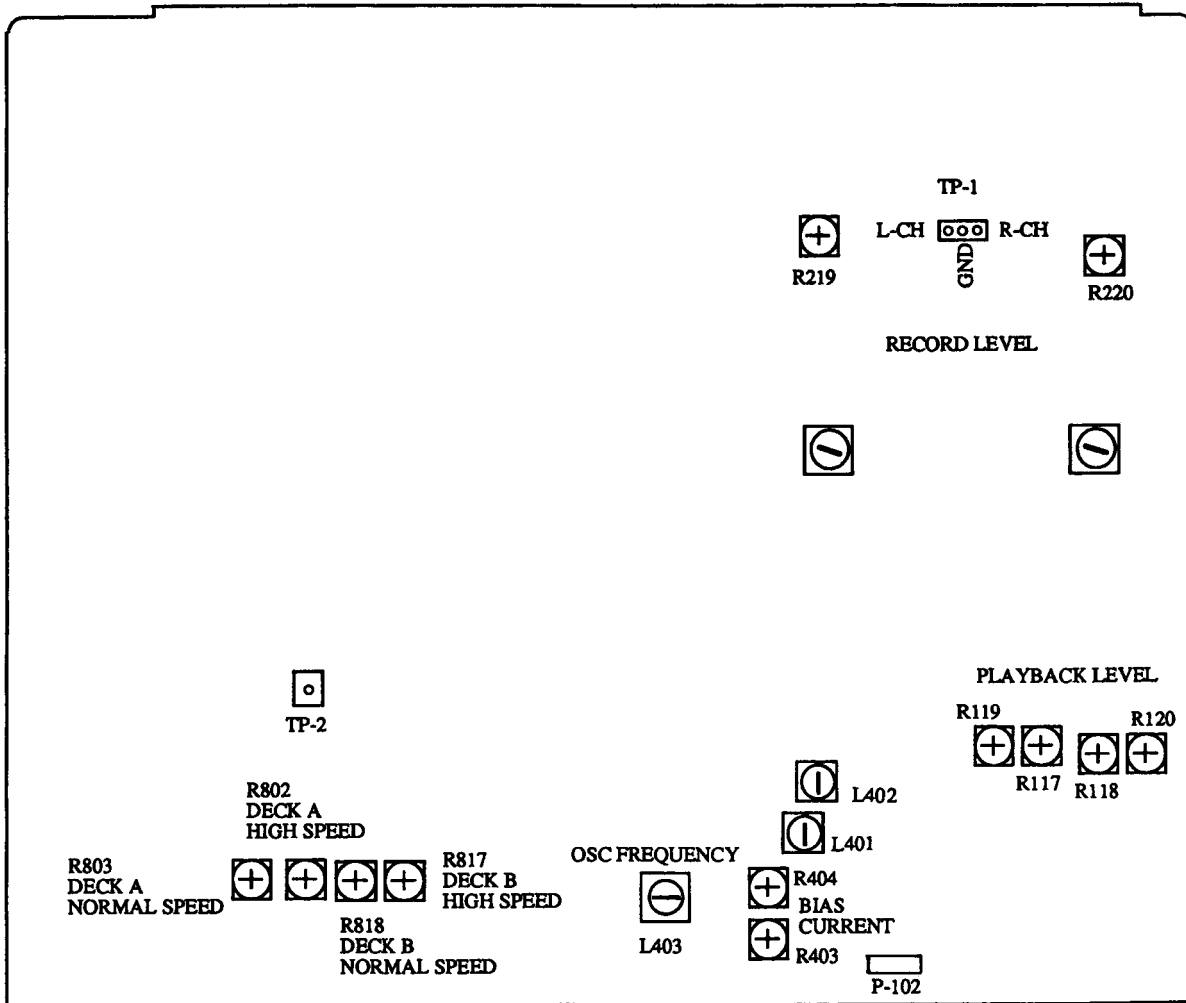

Adjustment point

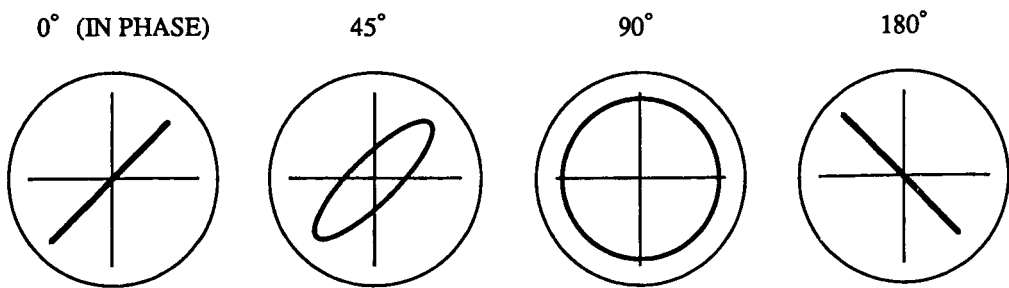

Confirming phase relationship

Fig. 1

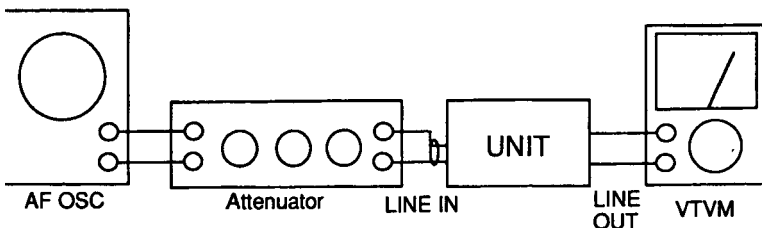

Fig. 2

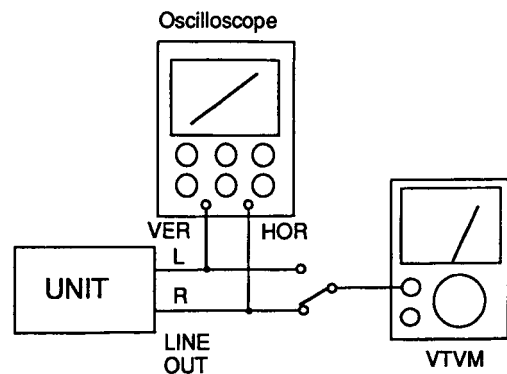
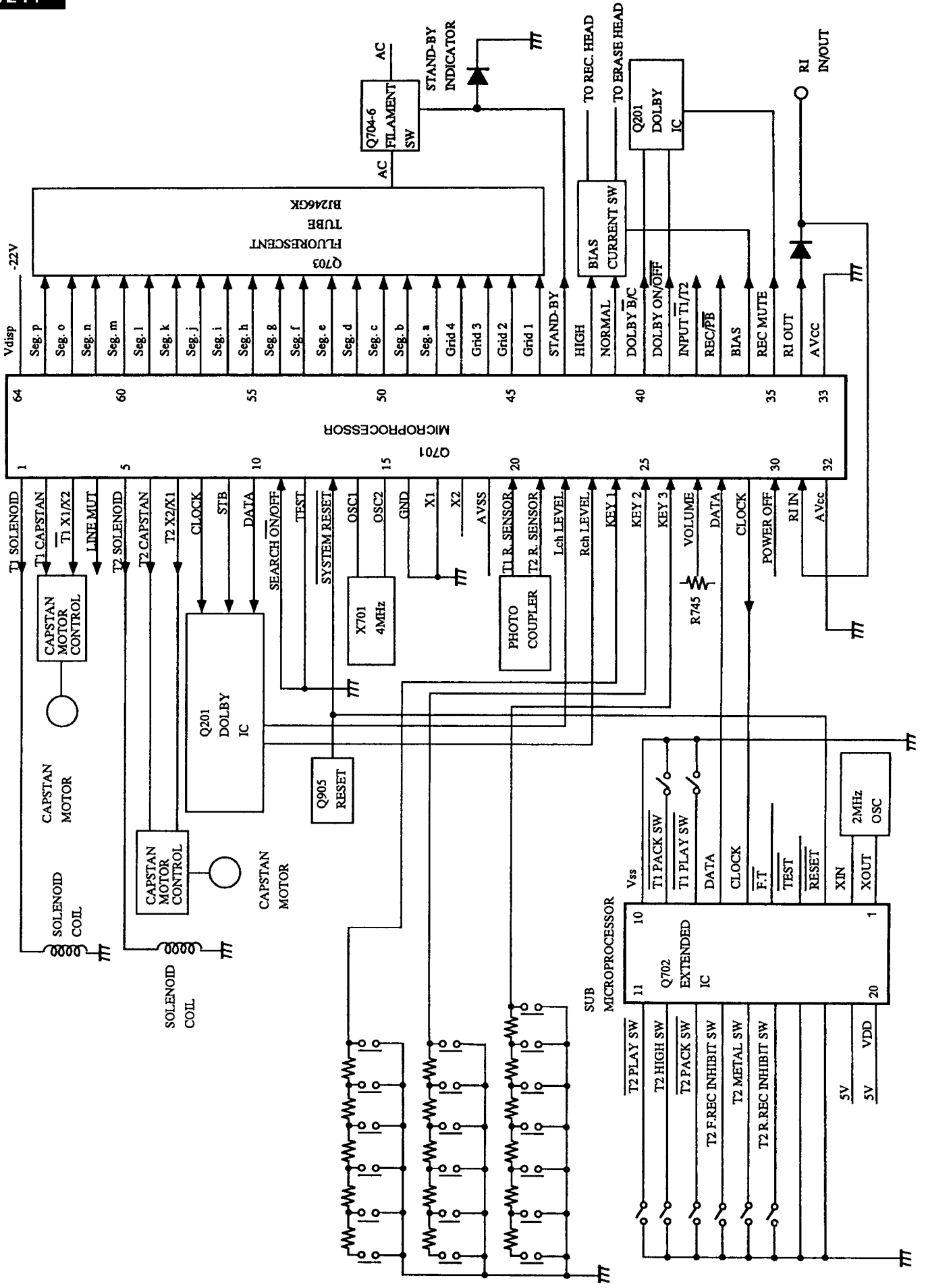

Fig. 1

Head azimuth adjustment

# MICROPROCESSOR - CONNECTION DIAGRAM



## MICROPROCESSOR - TERMINAL DESCRIPTIONS

Pin No.	Function	Description	Remarks
1	T1 SOLENOID	Solenoid control output terminal	H
2	T1 CAPSTAN	Capstan motor control output terminal	H
3	T1 X1/X2	Capstan motor rotation control output terminal	H:Normal speed L: Double speed
4	LINE MUTE	Muting control output terminal	H
5	T2 SOLENOID	Solenoid control output terminal	H
6	T2 CAPSTAN	Capstan motor control output terminal	H
7	T2 X1/X2	Capstan motor rotation control output terminal	H:Normal speed L: Double speed
8	CLOCK	Serial transfer data output terminals with Doably IC	Clock output
9	STB		Strobe output
10	DATA		Data output
11	SEARCH ON/OFF	Initializing terminal of skip operation	L
12	TEST	Test terminal	Connect to 5V.
13	RESET	System reset terminal	L
14	OSC1	Clock input/output terminal to internal oscillator	
15	OSC2	Connect the 4 MHz ceramic resonator.	
16	GND	Ground terminal	
17	X1	Clock input/output terminals for resonator for timer	
18	X2	Not used.	
19	AVss	Power source terminal for A/D converter	Connect the ground.
20	T1 R. SENSOR	Signal input terminal from rotation sensor	
21	T2 R. SENSOR	Signal input terminal from rotation sensor	
22	L ch LEVEL	A/D input terminal for level input	
23	R ch LEVEL	Use the skip and indicator of level meter	
24	KEY 1	Operation key connection terminals	
25	KEY 2		
26	KEY 3		
27	VOLUME	A/D input terminal for volume position detection	
28	DATA	Transfer terminal with input extended microprocessor	Data input
29	CLOCK		Clock output
30	POWER OFF	Power stoppage detection input terminal	H
31	RI IN	System code input terminal	
32	AVcc	Power source terminal for A/D converter	
33	Vcc	Power source terminal	
34	RI OUT	System code output terminal	H
35	REC MUTE	Recording muting control output terminal	H
36	BIAS	Bias control output terminal	H
37	REC/PB	Recording/playback head selection terminal	
38	INPUT T1/T2	Playback equalizer selection terminal	
39	DOLBY ON/OFF	Dolby mode selection terminal	
40	DOLBY B/C	Refer table 1.	
41	NORMAL	Playback equalizer and bias selector terminal	
42	HIGH	Refer table 2.	
43	STAND-BY LED	Stand-by indicator and filament control output terminal	H
44~47	Grid 4~Grid 1	Grid output terminals	H
48~63	Seg. a~Seg. p	Segment output terminals	H
64	Vdisp	Pull-down resistor connection terminals	

DOLBY ON/OFF	DOLBY B/C	DOLBY MODE
L	L	DOLBY OFF
L	H	DOLBY OFF
H	L	DOLBY B
H	H	DOLBY C

Table 1

TAPE	NORMAL	HIGH
NORMAL	H	L
HIGH	L	H
METAL	L	L

Table 2

## SUB MICROPROCESSOR

Pin No.	Function	Description
1	XOUT	Connect the 2 MHz ceramic resonator.
2	XIN	
3	RESET	Reset input
4	TEST	Test mode setting input of mechanism
5	F.T	Setting input of adjustment
6	CLOCK	Clock input
7	DATA	Data output
8	T1 PLAY SW	Play switch input
9	T1 PACK SW	Switch input for detection of tape loading
10	Vss	Ground terminal
11	T2 PLAY SW	Play switch input
12	T2 HIGH SW	Switch input for detection of type of cassette tape
13	T2 PACK SW	Switch input for detection of tape loading
14	T2 F.REC INH SW	Recording prevention detection switch input of forward direction
15	T2 METAL SW	Switch input for detection of type of cassette tape
16	T2 R.REC INH SW	Recording prevention detection switch input of reverse direction
17	NC	
18	NC	
19	NC	
20	VDD	Power source terminal





TA-RW144  
TA-RW244

G

F

E

D

C

B

A

# TA-RW144 SCHEMATIC DIAGRAM (1/2)

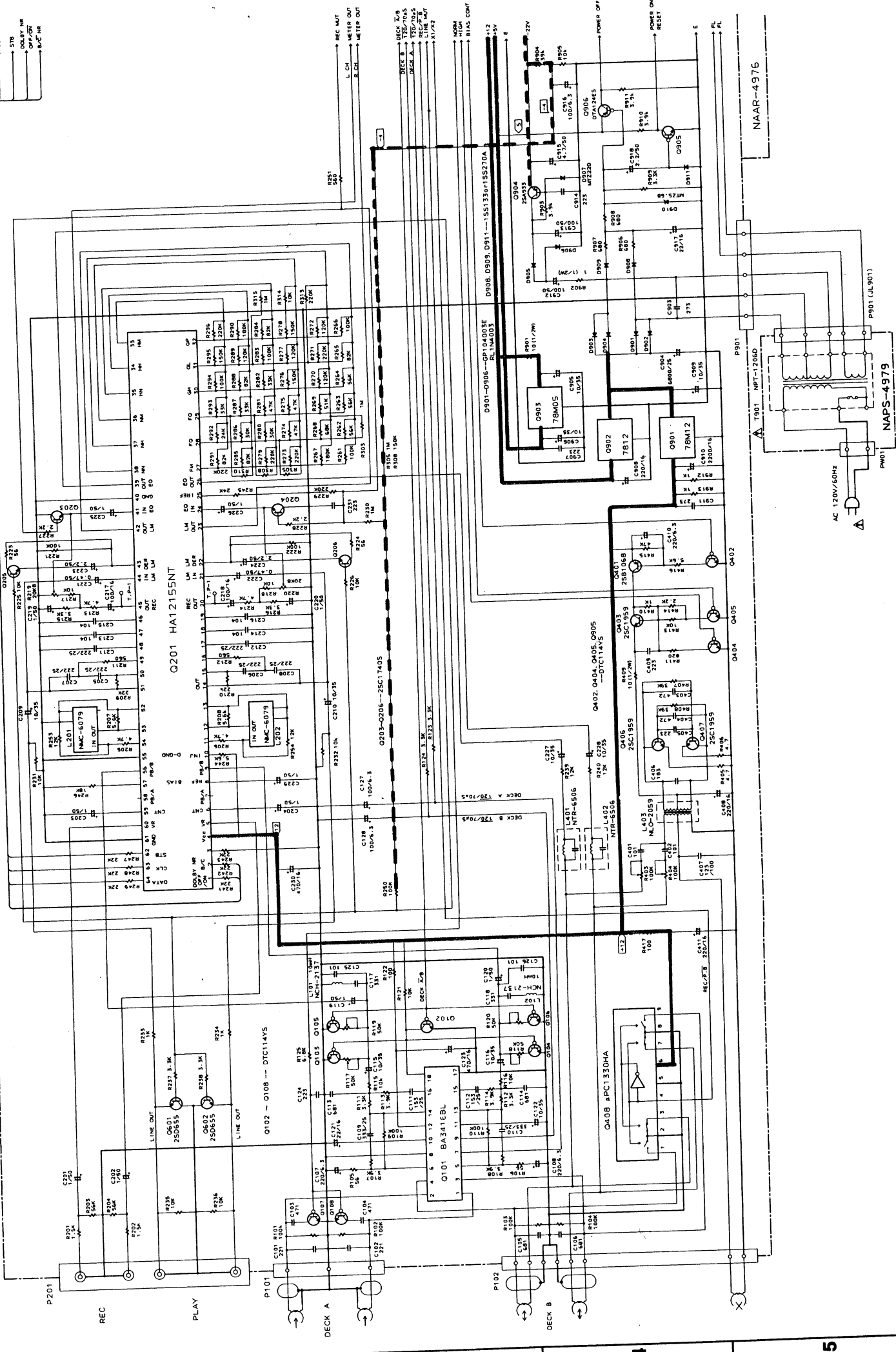

2

3

4

5

# PRINTED CIRCUIT BOARD - PARTS LIST

MAIN CIRCUIT PC BOARD (NAAR-4976-4A/4B/4C)			CIRCUIT NO.	PART NO.	DESCRIPTION
CIRCUIT NO.	PART NO.	DESCRIPTION		<b>Resonator</b>	
	<b>ICs</b>		X701	3010150	CST4.00MGW,Ceramic
				<b>Capacitors</b>	
Q101	22240767	BA3416BL			
Q201	22240544	HA12155NT	C107,C108	354722219	220 $\mu$ F,6.3V,Elect.
Q408	22240147	$\mu$ PC1330HA	C115,C116	354761009	10 $\mu$ F,35V,Elect.
Q701	22240765	HD404388A-07S	C119,C120	354780109	1 $\mu$ F,50V,Elect.
Q702	22240766	TMP47C102P-F017	C121,C917	354742209	22 $\mu$ F,16V,Elect.
Q901	222780125	78M12	C122	354761009	10 $\mu$ F,35V,Elect.
Q902	222780120 or 222780124	7812 or 7812HF	C123,C230 C127,C128	354744719 354721019	470 $\mu$ F,16V,Elect. 100 $\mu$ F,6.3V,Elect.
Q903	222780055	78M05	C201-C204 C209,C210	354780109 354761009	1 $\mu$ F,50V,Elect. 10 $\mu$ F,35V,Elect.
	<b>Transistors</b>		C213-C216	374721044	0.1 $\mu$ F $\pm$ 5%,50V,Plastic
Q102-Q108	221281	DTC114YS	C217,C218	354741019	100 $\mu$ F,16V,Elect.
Q203-Q206	2213285 or	2SC1740S-S or	C219,C220	354780109	1 $\mu$ F,50V,Elect.
Q604	2213284	2SC1740S-R	C221,C222	354784799	0.47 $\mu$ F,50V,Elect.
Q401,Q801	2212853 or	2SB1068-K or	C223,C224	354780229	2.2 $\mu$ F,50V,Elect.
Q805	2212855	2SB1068-U	C225,C226	354780109	1 $\mu$ F,50V,Elect.
Q402	221281	DTC114YS	C227,C228	354761009	10 $\mu$ F,35V,Elect.
Q403	2211544	2SC1959-Y	C229,C601	354780109	1 $\mu$ F,50V,Elect.
Q404,Q405	221281	DTC114YS	C403,C404	374724725	4700pF $\pm$ 10%,50V,Plastic
Q406,Q407	2211544	2SC1959-Y	C405	374722234	0.022 $\mu$ F $\pm$ 5%,50V,Plastic
Q601,Q602	2211705 or	2SD655-E or	C406	374721834	0.018 $\mu$ F $\pm$ 5%,50V,Plastic
Q705,Q706	2211706	2SD655-F	C407	370131234	0.012 $\mu$ F $\pm$ 5%,100V,Plastic
Q603,Q704	2213355 or	2SA933S-S or	C408,C411	354742219	220 $\mu$ F,16V,Elect.
Q804,Q807	2213354	2SA933S-R	C410	354722219	220 $\mu$ F,6.3V,Elect.
Q802,Q803	221281	DTC114YS	C702	374721044	0.1 $\mu$ F $\pm$ 5%,50V,Plastic
Q806,Q808	221281	DTC114YS	C711,C805	354761009	10 $\mu$ F,35V,Elect.
Q809,Q813	2212853 or 2212855	2SB1068-K or 2SB1068-U	C712	354744709	47 $\mu$ F,16V,Elect.
Q810,Q811	221281	DTC114YS	C903,C911	374722734	0.027 $\mu$ F $\pm$ 5%,50V,Plastic
Q812,Q815	2213355 or	2SA933S-S or	C904	3504168	13000 $\mu$ F,25V,Elect. <P/W>
Q904	2213354	2SA933S-R		3504210	6800 $\mu$ F,25V,Elect. <D>
Q814,Q816	221281	DTC114YS	C905,C906	354761009	10 $\mu$ F,35V,Elect.
Q905	221281	DTC114YS	C908	354742219	220 $\mu$ F,16V,Elect.
Q906	2212600	DTA124ES	C909	354761009	10 $\mu$ F,35V,Elect.
	<b>Diodes</b>		C910	393342227	2200 $\mu$ F,16V,Elect.
D701	223163 or	1SS133 or	C912,C913	354781019	100 $\mu$ F,50V,Elect.
D702,D703	223205	1SS270A	C915	354780479	4.7 $\mu$ F,50V,Elect.
D801,D802	224470562	MTZJ5.6B	C916	354721019	100 $\mu$ F,6.3V,Elect.
D901-D906	22380035	GP104003E	C918	354780229	2.2 $\mu$ F,50V,Elect.
D907	224472204	MTZJ22D			<b>Resistors</b>
D908,D909	223163 or	1SS133 or	R117-R120	5210265	N06HR50KBC,Trim
D911	223205	1SS270A	R219,R220	5210263	N06HR20KBC,Trim
D910	224470562	MTZJ5.6B	R403,R404	5210266	N06HR100KBC,Trim
	<b>Coils</b>		R409,R901	443521004	10 $\Omega$ ,1/2W,Metal oxide
L101,L102	231089	NCH-2137	R802,R817	5210259	N06HR2KBC,Trim
L201,L202	233407	NMC-6079	R803,R818	5210258	N06HR1KBC,Trim
L401,L402	231165	NTR-6506	R902	453530104	1 $\Omega$ ,1/2W,Metal
L403	231215	NLO-2059			

CIRCUIT NO.	PART NO.	DESCRIPTION
	<b>Plugs</b>	
P101,TP1	25055133	NPLG-3P117
P102	25055138	NPLG-8P122
	<b>Terminals</b>	
P201	25045329	NPJ-4PDBL183,Output
P502	25045330	NPJ-2PDBL184,RI
	<b>Socket</b>	
P701	25050861	NSCT-29P656
	<b>Wire traps</b>	
P702	25051087	NSCT-3P874
P801	25051104	NSCT-10P891
P802	25051129	NSCT-13P916
P901B	25050269	NSCT-5P97

**DISPLAY CIRCUIT PC BOARD (NADIS-4977-4A/4B/4C)**

CIRCUIT NO.	PART NO.	DESCRIPTION
Q703	212130	BJ246GK,FL tube
D704	225290	SEL4110R,LED
S701-S719	25035652	NPS-111-S604,Switches
P701A	25050893	NSCT-29P688,Socket
Q703a	27190939Y	Holder FL

**INPUT VOLUME PC BOARD (NAAF-4978-4A/4B/4C)**

CIRCUIT NO.	PART NO.	DESCRIPTION
R745	5104337Y	N09RL20KB15,Variable resistor
P702a	25051087	NSCT-3P874,Wire holder

**POWER SUPPLY PC BOARD (NAPS-4979-4A/4B)**

CIRCUIT NO.	PART NO.	DESCRIPTION
P901	25051109	NSCT-5P896,Wire holder <D/P>
PW01	25055676	NPLG-2P632,Plug <D/P>

**POWER SUPPLY PC BOARD (NAPS-4980-4C)**

CIRCUIT NO.	PART NO.	DESCRIPTION
P901A	25051109	NSCT-5P896,Wire holder <W>
PW01	25055676	NPLG-2P632,Plug <W>

**POWER SWITCH PC BOARD (NASW-6004-4B/4C)**

CIRCUIT NO.	PART NO.	DESCRIPTION
C901	3500191	△ DE7150F103M AC400/125V, IS capacitor <P/W>
S951	25065363	△ NPS-111-L590P, Power switch <P/W>
P952	2009990448ULY	NSAS-4P0599, Socket
C901a	27301216	△ Cover, capacitor <P/W>

**VOLTAGE SELECTOR SWITCH PC BOARD (NASW-6005-4C)**

CIRCUIT NO.	PART NO.	DESCRIPTION
S952	25065437	△ NSS-22157P, Push switch <W>

NOTE: <D>: 120V model only  
<P>: 230V model only  
<W>: Worldwide model only

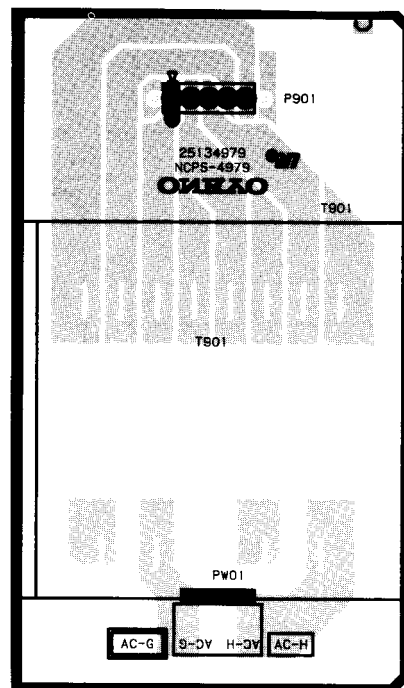

**POWER SUPPLY PC BOARD  
(Worldwide model)**

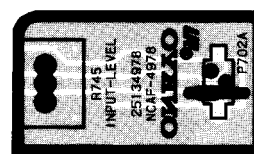

**INPUT VOLUME PC BOARD**

NOTE: THE COMPONENTS IDENTIFIED BY MARK △ ARE CRITICAL FOR RISK OF FIRE AND ELECTRIC SHOCK. REPLACE ONLY WITH PART NUMBER SPECIFIED.

**SCHEMATIC DIAGRAM (2/2)**

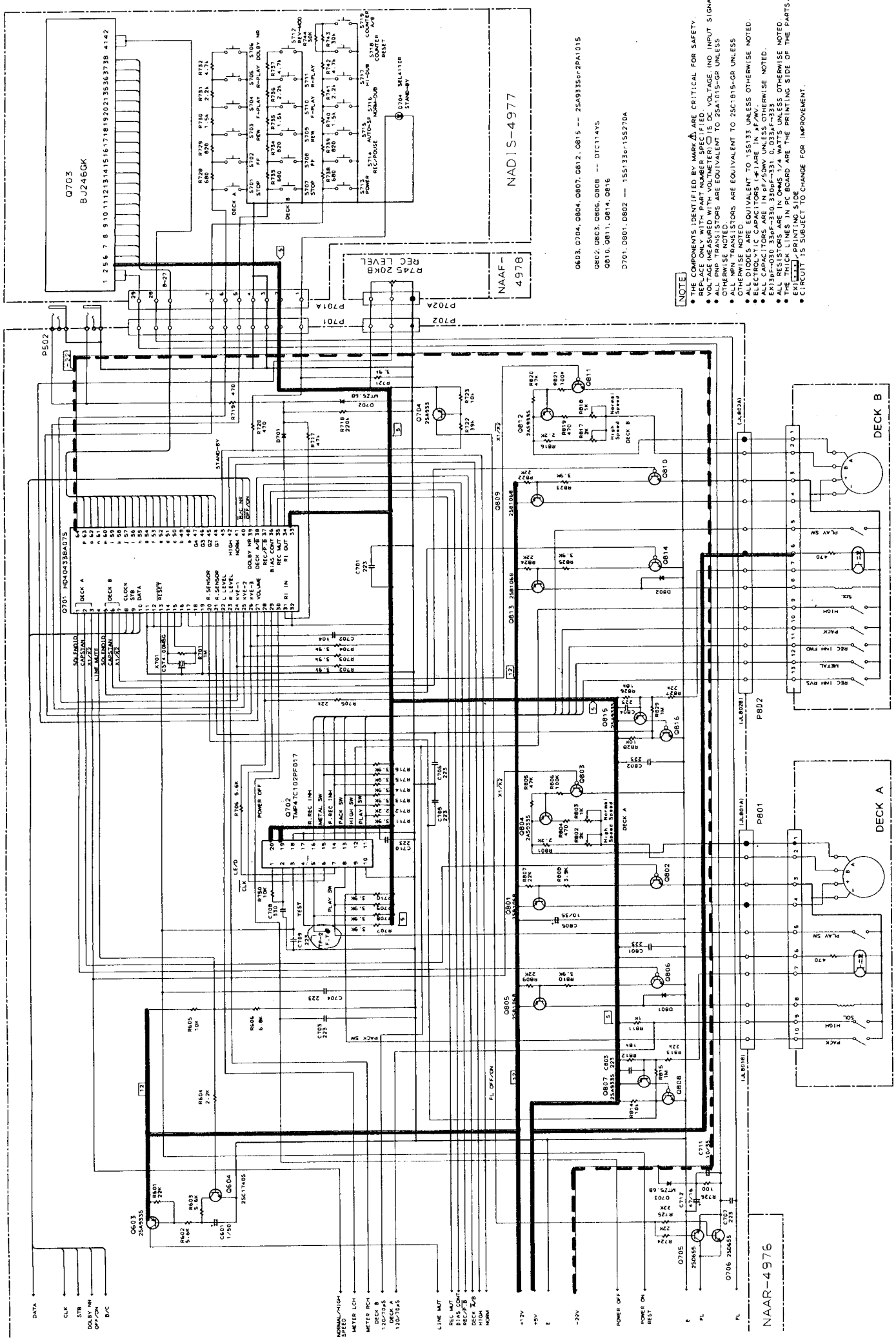

**NOTE**

- THE COMPONENTS IDENTIFIED BY MARK **(A)** ARE CRITICAL FOR SAFETY. REPLACE ONLY WITH PART NUMBER SPECIFIED.
- VOLTAGE MEASURED WITH VOLTMETER **(V)** IS DC VOLTAGE (NO INPUT SIGNAL) UNLESS OTHERWISE NOTED.
- OTHER SE NOTED OTHERWISE ARE EQUIVALENT TO 25A1015-GR UNLESS OTHERWISE NOTED.
- ALL NPN TRANSISTORS ARE EQUIVALENT TO 25C1815-GR UNLESS OTHERWISE NOTED.
- ELECTROLYTIC CAPACITORS **(E)** ARE IN  $\mu$ F/MV.
- ALL CAPACITORS ARE IN pF/50MV UNLESS OTHERWISE NOTED.
- EX138P-030 35pF-330 C. 0.033uF-333
- EX138P-030 35pF-330 C. 0.033uF-333
- THE THICK LINES IN PC BOARD ARE THE PRINTING SIDE OF THE PARTS. EXCEPT WHERE SHOWN OTHERWISE.
- CIRCUIT IS SUBJECT TO CHANGE FOR IMPROVEMENT.

Q603, Q704, Q804, Q807, Q812, Q815 -- 25A9335r2FA1015  
 Q802, Q803, Q806, Q808 -- D1C11AYS  
 Q810, Q811, Q814, Q816  
 Q701, D001, D802 -- 15S133r15S270A

MECHANISM - EXPLODED VIEW

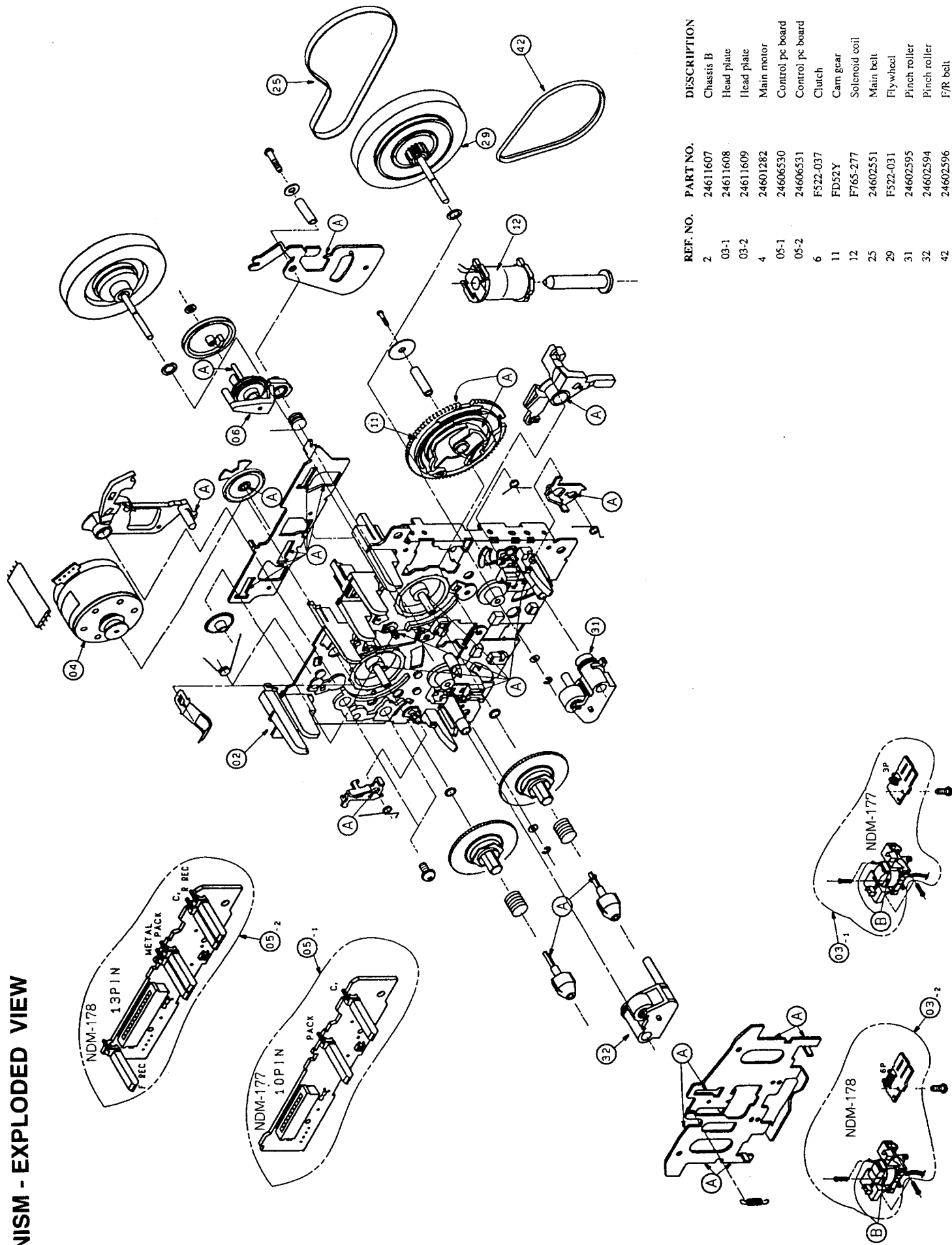

REF. NO.	PART NO.	DESCRIPTION
2	24611607	Chassis B
03-1	24611608	Head plate
03-2	24611609	Ilead plate
4	24601282	Main motor
05-1	24606530	Control pc board
05-2	24606531	Control pc board
6	F522-037	Clutch
11	FD52Y	Cam gear
12	F765-277	Solenoid coil
25	24602551	Main belt
29	F522-031	Flywheel
31	24602595	Pinch roller
32	24602594	Pinch roller
42	24602596	F/R belt

## PACKING VIEW

Model TA-RW244

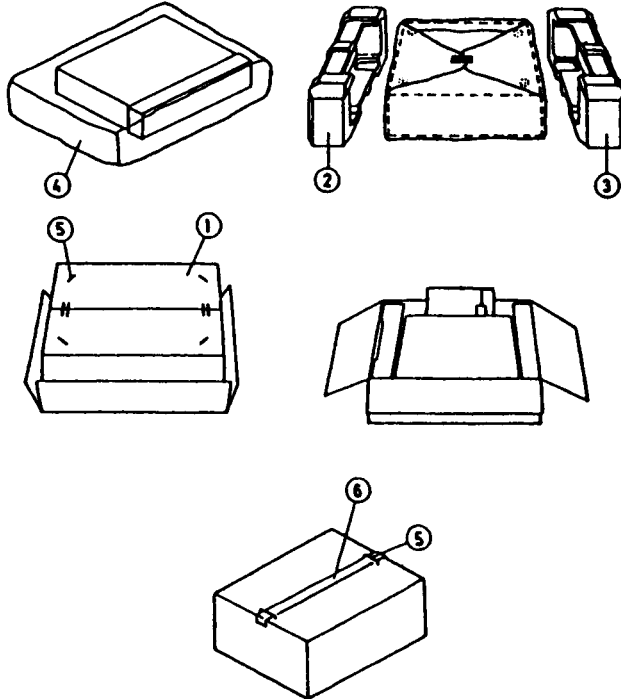

REF. NO.	PART NO.	DESCRIPTION
1	29053149Y	Carton box <B>
	29053150Y	Carton box <S>
2	29091637-1CY	Pad R
3	29091636-1CY	Pad L
4	29100034-1AY	650×850, Poly bag
5	282301	Staples
6	29110071	PP tape
	Accessory bag ass'y	
	2010244Y	Connection cord
	29342422Y	Instruction manual
	29342423Y	Instruction manual FSI <P>
	29342424Y	Instruction manual GSWD <P>
	29342425Y	Instruction manual T <W>
	25055018	CV-K-1, Conversion plug <W>
	29100097-1AY	320×250, Poly bag

NOTE: <P>:230 V model only  
<W>:Worldwide model only  
<B>:Black model only  
<S>:Silver model only

TA-RW144  
TA-RW244

## PACKING VIEW

Model TA-RW144

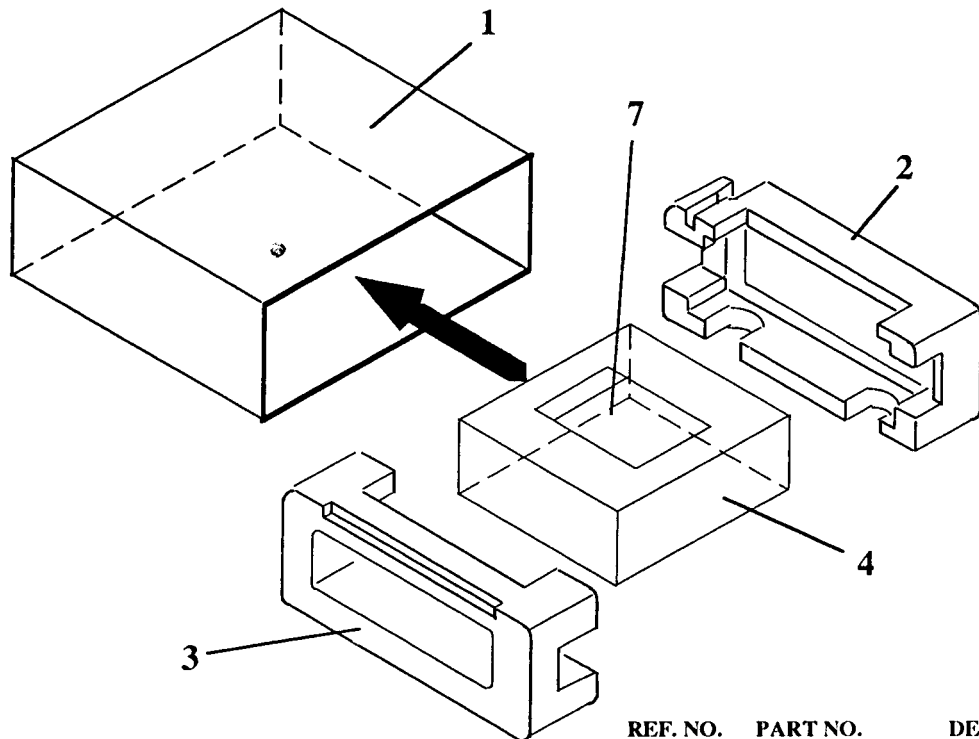

REF. NO.	PART NO.	DESCRIPTION
1	29053148Y	Carton box
2	29091637-1CY	Pad R
3	29091636-1CY	Pad L
4	29100034-1AY	650×850, Poly bag
7	Accessory bag ass'y	
	2010244Y	Connection cord
	2934242Y	Instruction manual
	29365019B	Warranty card
	29358002K	Service station list
	29100097-1AY	320×250, Poly bag

---

## ONKYO CORPORATION

International Sales Div. : 31 Sankyo-bld. 3-8-5, Asakusabashi, Taito-ku, TOKYO 111, JAPAN  
TEL : 03-5820-5865 FAX : 03-5820-5869

ONKYO U.S.A. CORPORATION  
200 Williams Drive, Ramsey, N.J. 07446, U.S.A.  
TEL : 201-825-7950 FAX : 201-825-8150