

ONKYO SERVICE MANUAL

Ref. No. 3446

STEREO CASSETTE TAPE DECK MODEL TA-RW313



Black model

UND, UDC, UD	120V AC, 60Hz
UP	230V AC, 50Hz
UW	120V or 220V AC, 50/60Hz
UQA	240V AC, 50Hz

SAFETY-RELATED COMPONENT WARNING!!

COMPONENTS IDENTIFIED BY MARK Δ ON THE SCHEMATIC DIAGRAM AND IN THE PARTS LIST ARE CRITICAL FOR RISK OF FIRE AND ELECTRIC SHOCK. REPLACE THESE COMPONENTS WITH ONKYO PARTS WHOSE PARTS NUMBERS APPEAR AS SHOWN IN THIS MANUAL.

MAKE LEAKAGE-CURRENT OR RESISTANCE MEASUREMENTS TO DETERMINE THAT EXPOSED PARTS ARE ACCEPTABLY INSULATED FROM THE SUPPLY CIRCUIT BEFORE RETURNING THE APPLIANCE TO THE CUSTOMER.

ONKYO.
AUDIO COMPONENTS

SPECIFICATIONS

Track System:	4-tracks, 2-channels
Erasing System:	AC erase
Tape Speed:	4.8 cm/sec. (1-7/8 i.p.s.) 9.6 cm/sec. (3-3/4 i.p.s.) (high speed dubbing)
Wow and Flutter:	0.07% (WRMS)
Frequency Response:	20 – 15,000Hz (Normal) (30 – 14,000Hz \pm 3dB) 20 – 16,000Hz (High) (30 – 15,000Hz \pm 3dB) 20 – 17,000Hz (Metal) (30 – 16,000Hz \pm 3dB)
S/N Ratio:	Dolby NR off: 58dB (metal position tape) A noise reduction of 10dB above 5kHz and 5dB at 1kHz is possible with Dolby B NR. A noise reduction of 20dB at 5kHz is possible with Dolby C NR.
Input Jacks:	Line IN: 2 Input sensitivity: 80mV Input impedance: 50 kohms
Outputs:	Headphone jack: 1 Optimum load impedance: 8 to 200 ohms Line OUT: 2 Standard output level: 500mV (0dB) Optimum load impedance: over 50 kohms
Motors:	DC servo motor x 2; DC motor x 2
Heads:	REC/PB: 1 PB: 1 ERASE: 1
Power Supply Rating:	European models: AC 230V, 50Hz Canadian models: AC 120V, 60Hz Worldwide models: AC 120V and 220V switchable, 50/60Hz
Power Consumption:	34 watts
Dimensions:	455(W) x 120(H) x 306(D)mm (17-15/16" x 4-3/4" x 12-1/16")
Weight:	5.5 kg. (12.1 lbs.)

Specifications and external appearance are subject to change without notice because of product improvements.

BLOCK DIAGRAM

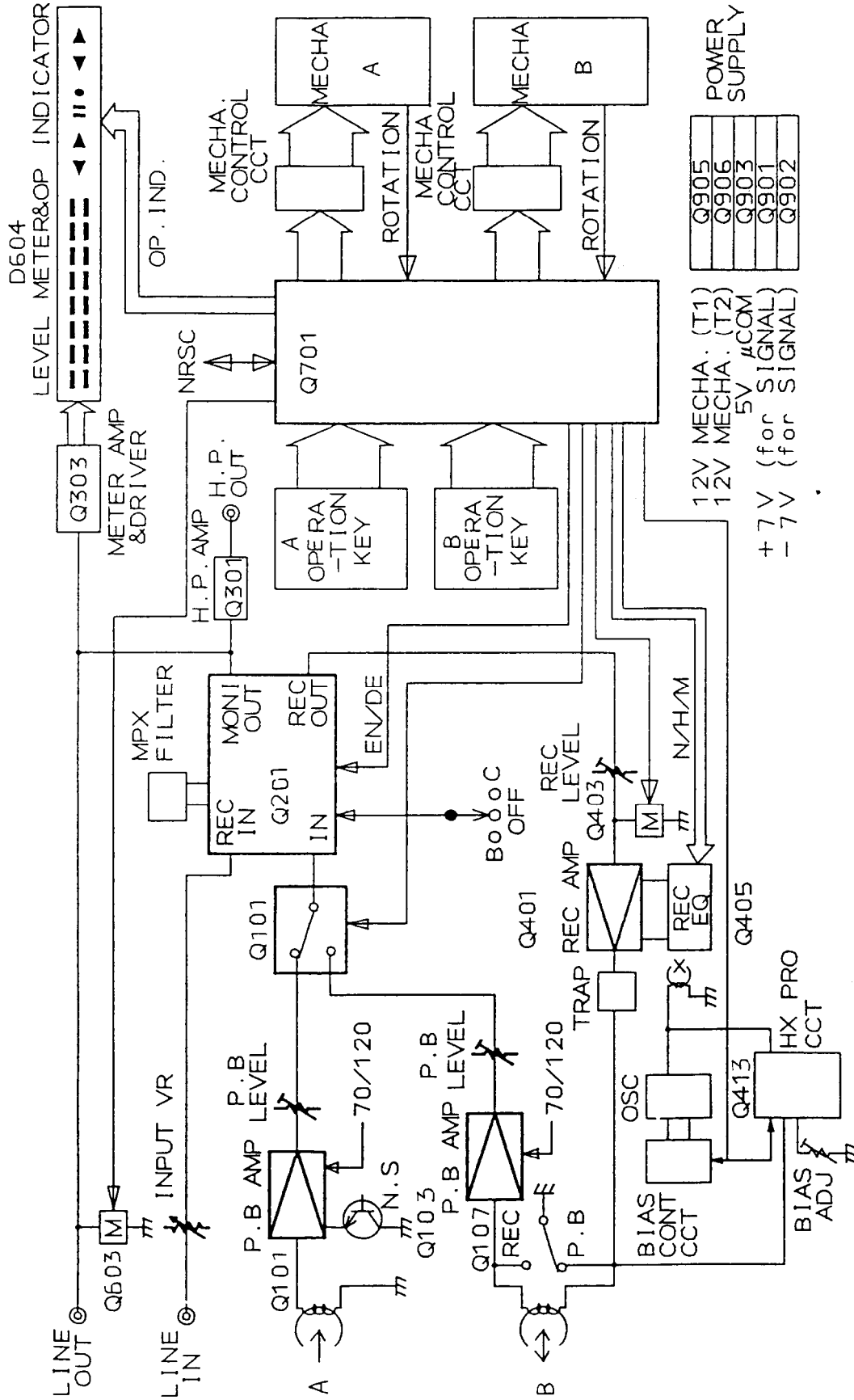

TAPE MECHANISM-EXPLODED VIEW (DECK-B)

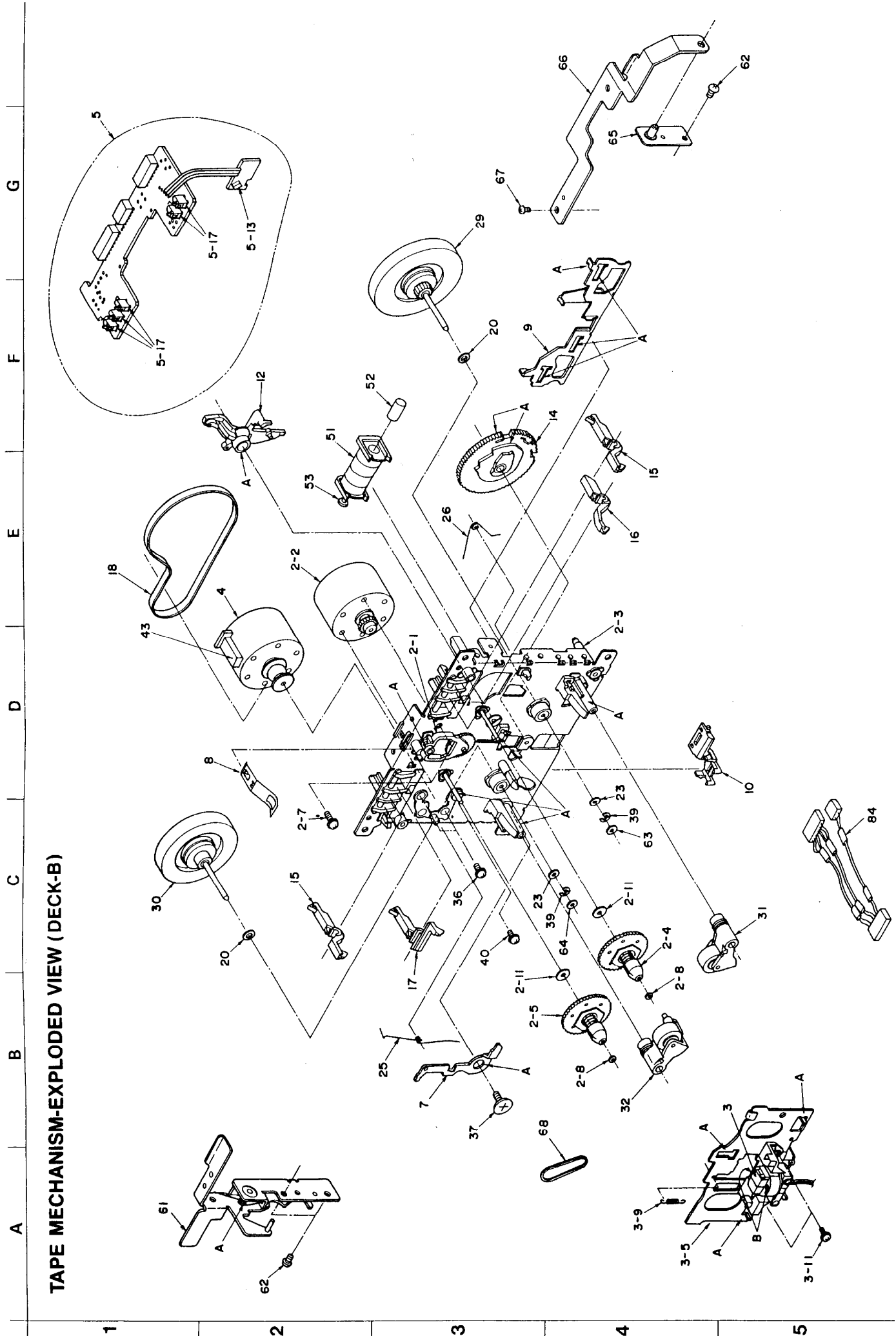

A B C D E F G

TAPE MECHANISM-EXPLODED VIEW (DECK-A)

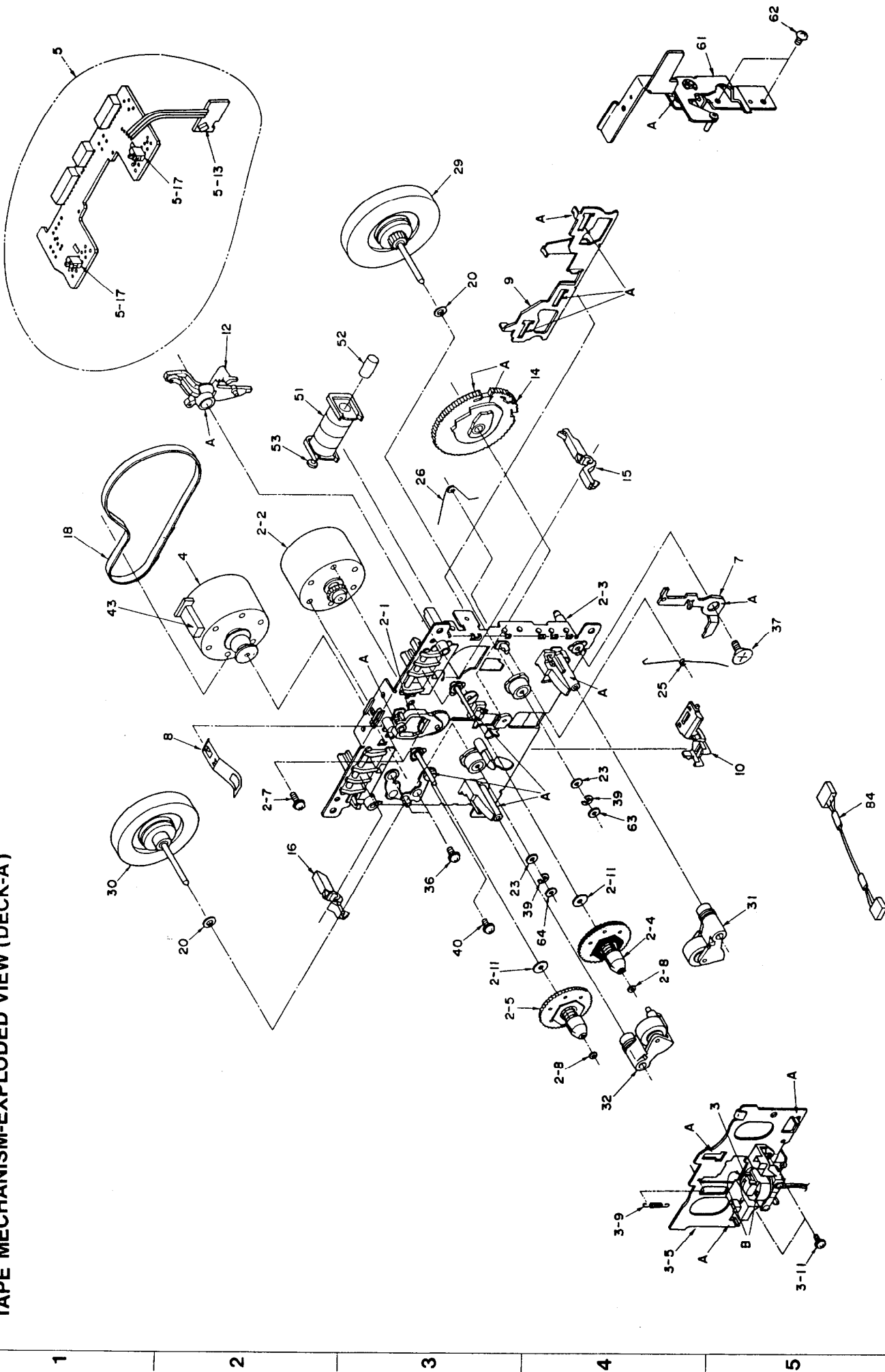

MICROCOMPUTER TERMINAL DESCRIPTION

No.	Name	IN/OUT	Function
1	X1 DUBBING LED	O	Dubbing indication, H:ON
2	X2 DUBBING LED	O	Dubbing indication, H:ON
3	T1 REV. LED	O	REV play indication, H:ON
4	T1 FWD. LED	O	FWD play indication, H:ON
5	REC. MUTE	O	Recording muting, H:ON
6	INPUT SEL. T2/T1	O	T1/T2 play back signal selection
7	BIAS CONTROL	O	Bias oscillation control, H:ON
8	REC/PB	O	REC/PB selection
9	SPEED X1/X2	O	Tape speed selection
10	T2 AUTO SPACE	I	Auto space operation
11	T2 REC/PAUSE	I	REC/PAUSE operation
12	T2 FWD-PALY	I	FWD-PLAY operation
13	T2 REV-PALY	I	REV-PLAY operation
14	T2 FF	I	Fast forward operation
15	T2 REW	I	Rewind operation
16	X2 DUBBING	I	Dubbing operation
17	X1 DUBBING	I	Dubbing operation
18	T1 ROTATION-SENSOR	I	Reel rotation sensor
19	T2 ROTATION-SENSOR	I	Reel rotation sensor
20	METAL SW.	I	Record equalizer selection (METAL)
21	T2 SIDE-A REC. INH.	I	Recording prevention
22	T2 CASSETTE IN	I	Cassette loading detection (SIDE-A)
23	CrO ₂ SW.	I	Record equalizer selection (HIGH)
24	T2 SIDE B REC. INH.	I	Recording prevention (SIDE-B)
25	T1 CASSETTE IN	I	Cassette loading detection
26	MODE \curvearrowright / \curvearrowleft	I	Reverse mode selection
27	P-OFF	I	Power OFF detection
28	T1 CAPSTAN ON/OFF	O	Capstn motor control
29	T2 CAPSTAN ON/OFF	O	Capstan motor control
30	T1 SPEED X2/X1	O	Tape speed control
31	T2 SPEED X2/X1	O	Tape speed control
32	V _{CC}		V _{CC} +5V
33	NRSC IN	I	Remote control signal
34	NRSC OUT	O	Remote control signal
35	LINE MUTE	O	Line muting
36	NOT USED		
37	T2 REEL-FF	O	Reel motor rotation fast forward
38	T2 REEL-REW	O	Reel motor rotation in rewind
39	T2 O-PLAY	O	Reel motor rotation PLAY with "H"
40	T2 SOLENOID	O	Solenoid drive
41	T1 REEL-FF	O	Reel motor rotation fast forward
42	T1 REEL-REW	O	Reel motor rotation in rewind
43	T1 O-PLAY	O	Reel motor rotation PLAY with "H"
44	T1 SOLENOID	O	Solenoid drive
45	T1 REW	I	Key input to cause rewind
46	T1 FF	I	Key input to cause fast forward
47	T1 REW-PALY	I	Key input to casue REV-PLAY
48	T1 FWD-PALY	I	Key input to cause FWD-PLAY
49	SYSTEM RESET		System reset for microcomputer
50	TEST		
51, 52	OSC1, OSC2		System clock OSC
53	GND		GND
54	NOT USED		
55	NOT USED		
56	F.T		
57	DOLBY ENC/DEC	O	Dolby ENC/DEC selector
58	TAPE SEL. METAL	O	Tape selector
59	TAPE SEL. HIGH	O	Tape selector
60	TAPE SEL. NORMAL	O	Tape selector
62	T2 FWD. LED	O	FWD indication, H:ON
61	T2 REV. LED	O	REV indication, H:ON
59	T2 REC. LED	O	REC indication, H:ON
60	T2 PAUSE LED	O	PAUSE indication

MICRO COMPUTER (HD614049SA83)

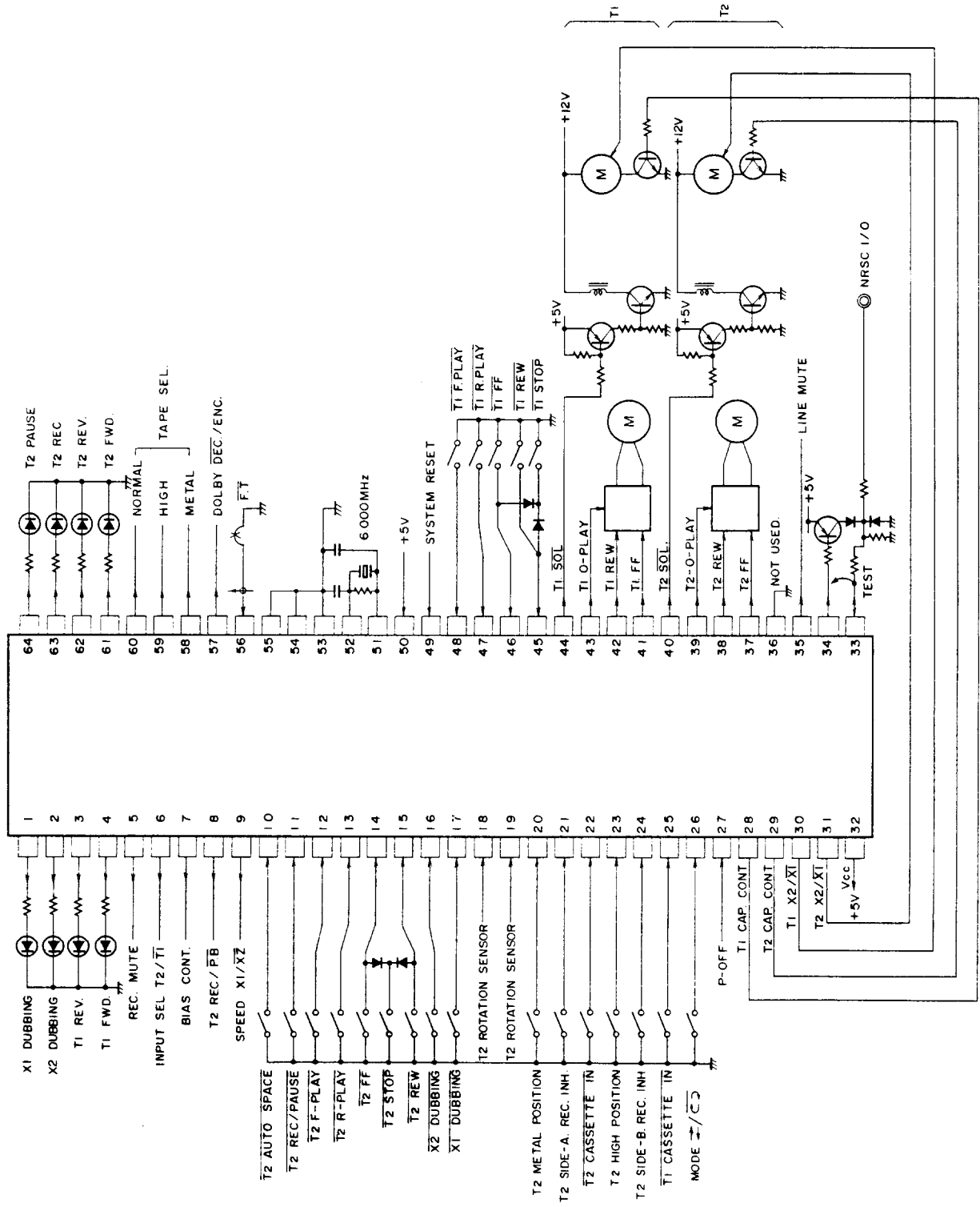

ADJUSTMENT PROCEDURES

PRECAUTIONS

- Before adjustment, clean the following parts with an alcohol moistend swab.
 - * record/playback head
 - * pinch roller
 - * erase head
 - * capstan
- Do not use magnetized screwdriver for adjustments.
- Demagnetize record/playback head with a head demagnetizer.

TEST EQUIPMENT/TOOLS REQUIRED:

- Audio oscillator
- Digital frequency counter
- Oscilloscope
- Attenuator
- AC voltmeter
- Non-magnetic screw driver
- Test tapes
 - TCC-153 : 10 KHz, - 5dB
 - MTT-111 : 3 kHz, - 0dB
 - MTT-150 : Dolby level calibration
400Hz, tone 200nWb/m

Item	Connection of instrument	Line input	Test tape	Mode	Output indicator	Adjustment point	Adjust	Remarks
1	Tape speed Frequency counter to LINE output terminal		MTT-111	PB	Frequency counter	T1 Normal R728 T1 High R731 T2 Normal R747 T2 High R750	3005±5Hz 6010±10Hz 3005±5Hz 6010±10Hz	High speed connect the TP5 (T1) to GND TP-6 (T2) to GND High speed first
2	Head azimuth AC voltmeter and oscilloscope to LINE output terminal		TCC-153	PB	AC voltmeter	Haed azimuth screw	Maximum and same phase at channels L and R	fig-1
3	Play-back level AC voltmeter to terminals TP-3 and TP-4		MTT-150	PB	AC voltmeter	T1 R113 (Ch.L) T1 R114 (Ch.R) T2 R131 (Ch.L) T2 R132 (Ch.R)	300mV	
4	OSC Block Frequency counter to P401 read loose coupling		T2 METAL TAPE MX-C90	T2 REC	Frequency counter	L403	85kHz±2kHz	
5	HX-PRO AC voltmeter to terminals TP-1 and TP-2		METAL TAPE	REC	AC voltmeter	L-405 (Ch.L) L-406 (Ch.R)	Maximum	R-473 R-474 clock wise (max)
6	Bias current fig-2	1kHz, -20dB and 12kHz, -20dB	XL-II C-90	REC/PB	AC voltmeter	R473 (Ch.L) R474 (Ch.R)	Same level at REC/PB	Input VR maximum.
7	Record level fig-2	1kHz	XL-II C-90	REC	AC voltmeter	Attenuator or AF OSC output	350mV	
				REC/PB	AC voltmeter	R405 (Ch.L) R406 (Ch.R)	Same level at REC/PB	

Blank tape

NORMAL UD-1 C-90

HIGH XL-II C-90

METAL XS C-60

PLAY torque..... 30~70g/cm

FF. REW torque..... 80~180g/cm

Back tention 2~7g/cm

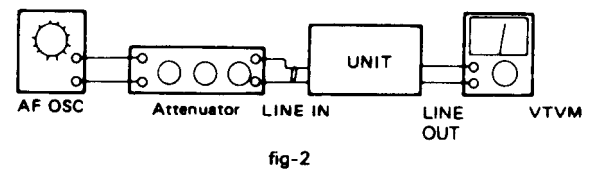
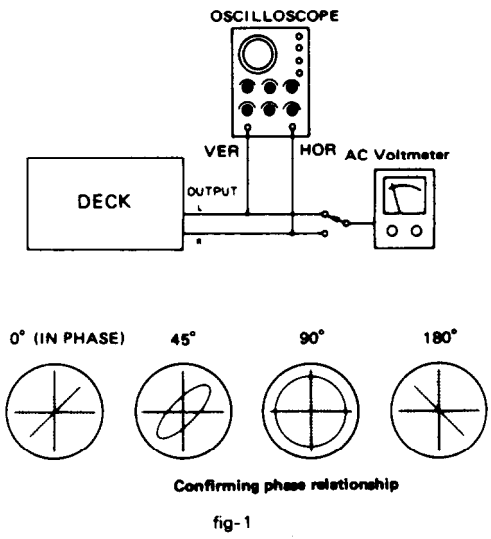
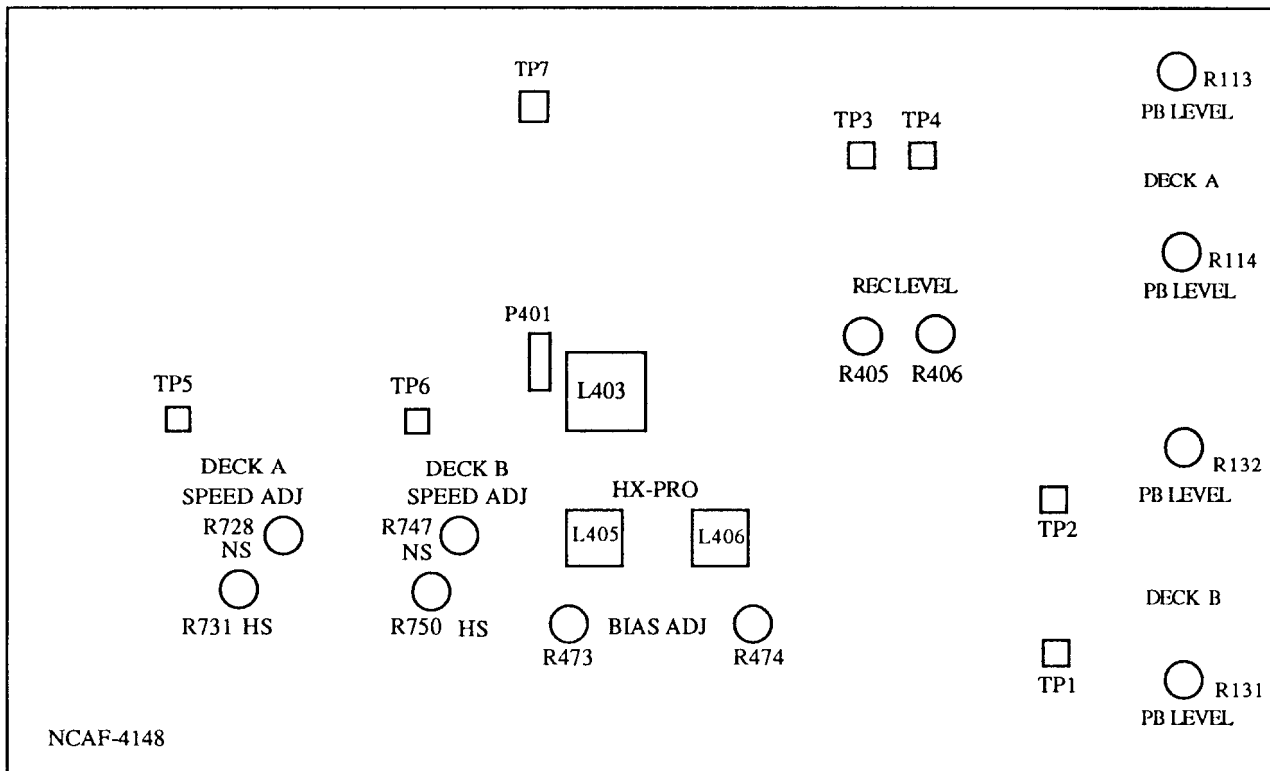

CHASSIS-EXPLODED VIEW

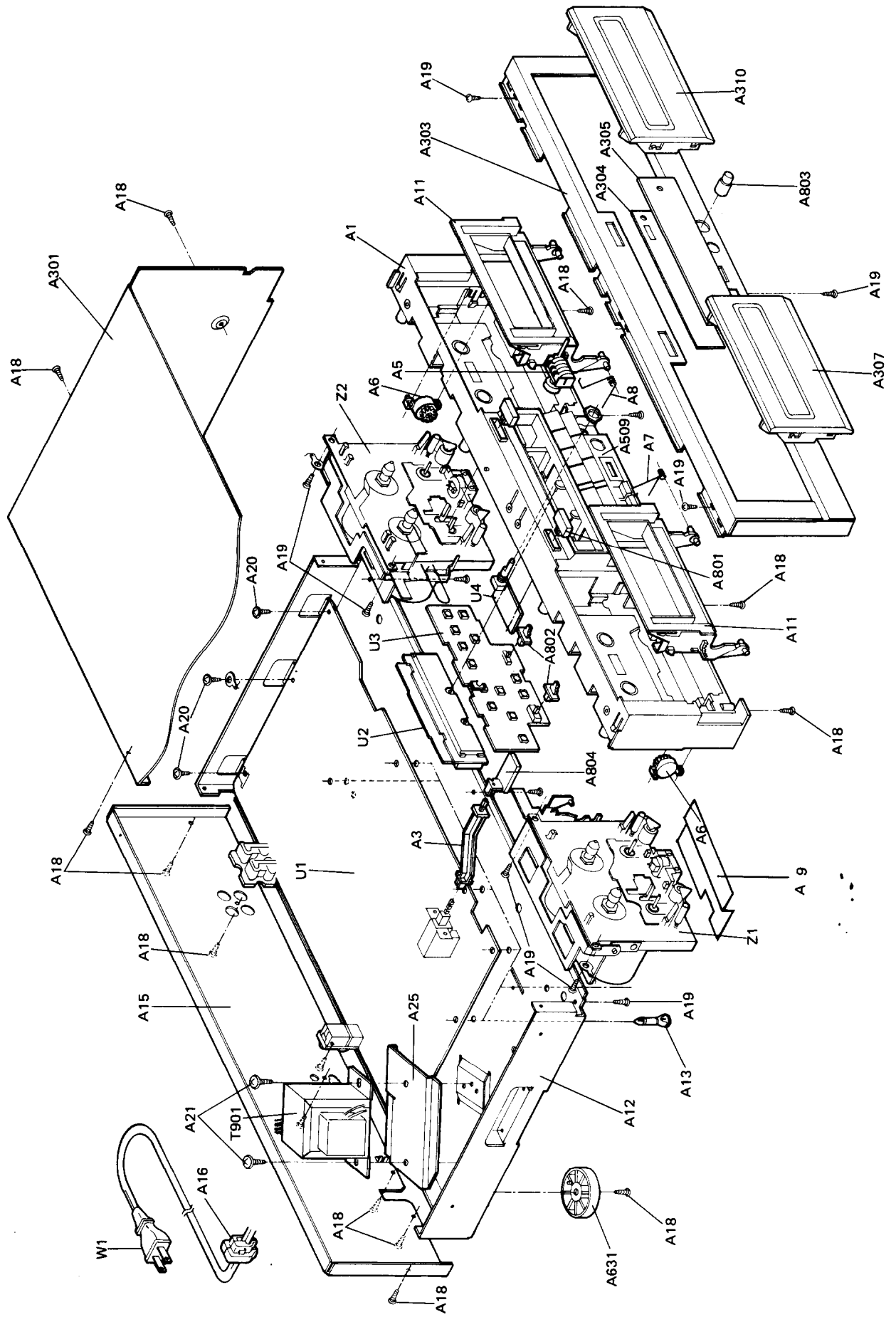

CHASSIS-EXPLODED VIEW PARTS LIST

REF. NO.	PART NO.	DESCRIPTION	REF. NO.	PART NO.	DESCRIPTION
A1	27110617BY•	FRONT BRACKET AS C X 003	T901	2300632	NPT-1100D (D)
A3	27273135BY	JOINT (POW)		2300633	NPT-1100P (G)
A5	24601220	TAPE COUNTER		2300634	NPT-1100DG (W)
A6	28400282	DAMPER		2300681	NPT-1100Q (Q)
A7	27180476A	SPRING (A)	U1	IN123548-4	NAAF-4148-4
A8	27180477B	SPRING (B)	U2	IN123549-4	NADIS-4149-4
A9	27130646DY	BRACKET (F)	U3	IN123550-4	NASW-4150-4
A11	28400473-1AY	FRAME AS (CASSETTE)	U4	IN123551-4	NAETC-4151-4
-a	28400463BY	FRAME (CASSETTE)	Z1	244176Y	CASSETTE DECK-A MECHANISM
-b	27180435Y	SPRING			NDM-167
-c	28141109Y	CUSHION			CASSETTE DECK-B MECHANISM
A12	27100233AY	CHASSIS	Z2	244177Y	NDM-168
A13	27190480	HOLDER			
A15	27121696AY	REAR PANEL (D)			
	27121697AY	REAR PANEL (G)			
	27121698AY	REAR PANEL (W)			
	27121764Y	REAR PANEL (Q)			
A16	27300750	BUSHING (CORD)			
A18	834430088	TAP-TIGHT SCREW 3TTS+8B(BC)			
A19	833430080	TAP-TIGHT SCREW 3TTP+8P(BC)			
A20	831130088	TAP-TIGHT SCREW 3TTW+8B			
A21	830440069	TAP-TIGHT SCREW 4x6			
A25	27130608DY	BRACKET (PT)			
A301	28184479Y	TOP COVER			
A302	28140837Y	CUSHION 250x10x.9t			
A303	1N148701K	FRONT PANEL			
A304	28133259Y	BACK PLATE			
A305	28191586Y	CLEAR PLATE			
A307•	27301652Y	CASSETTE LID (A)			
-a	27301654Y	WINDOW			
A310•	27301652-1Y	CASSETTE LID (B)			
-a	27301654Y	WINDOW			
A509	27215207Y	COSMETIC FRAME (D)			
A631	27175254AY	LEG AS			
A801	28324232Y	KNOB (EJ)			
A802	28324233Y	KNOB (DOL)			
A803	28324338	KNOB (VOL)			
A804	28324234Y	KNOB (POW)			
S902	25065123	NSS-1258P SWITCH (W)			
W1	253174Y	AC CORD AS-UC-6 #18 (D)			
	253164Y	AC CORD AS-CEE (G/W)			
	253170	AC CORD AS-SAA (Q)			

NOTE (D): Only 120V model
(G): Only 230V model
(W): Only worldwide model
(Q): Only 240V model

NOTE: THE COMPONENTS IDENTIFIED BY MARK  ARE CRITICAL FOR RISK OF FIRE AND ELECTRIC SHOCK. REPLACE ONLY WITH PART NUMBER SPECIFIED.

PRINTED CIRCUIT BOARD PARTS LIST

NAAF-4148-4

CIRCUIT NO.	PARTS NO.	DESCRIPTION	CIRCUIT NO.	PARTS NO.	DESCRIPTION
	ICs				
Q101, Q107	222956	NJM-2068D-D	Q904	2213285 or	2SC1740S-S or
Q111	222933 or	BU-4066B or		2213284	2SC1740S-R
	222840661	4066B	Q905, Q906	2202115 or	2SD2061-E or
Q201	22240388	HA12142NT		2202116	2SD2061-F
Q301	22240368 or	M5218AL or			
	222652	M5218L			Diodes
Q401	22240267	CXA1198AP	D601-D603	223163	1SS133
Q405	222840511	4051B	D701, D704	224450752	MTZ7.5B
Q413	222959	μ PC1297CA	D702, D705	224450433	MTZ4.3C
Q605	22240147	μ PC1330HA	D703	223163	1SS133
Q701	22240454	HD614049SA83	D706, D707	223163	1SS133
Q702	22240239	TA-7291S	D708	224150562	05AZ5.6Y
Q710	22240239	TA-7291S	D709	223163	1SS133
Q901	222780065MIT	78M06L	D901-D906	22380046	AM01Z
Q902	222790065MIT	79M06L	D907, D908	223163	1SS133
Q903	222780055MIT	78M05	D909	224150623	05AZ6.2Z
			D910	224151303	05AZ13Z
			D911, D914	223163	1SS133
	Transistors				Coils
Q103-Q106	2213285 or	2SC1740S-S or	L201, L202	233407	NMC-6079
	2213284	2SC1740S-R	L401, L402	231165	NTR-6506
Q109, Q110	2213285 or	2SC1740S-S or	L403	231063	NLO-2037
	2213284	2SC1740S-R	L405	231127	NCH-4183
Q113	221281 or	DTC114YS or			Crystal
	2213570	RN1207	X701	3010149	CST6.00MGW
Q203	221281 or	DTC114YS or			Capacitors
	2213570	RN1207	C111, C112	393142217	220 μ F16V. ELECT.
Q205	2212600 or	DTA124ES or	C123, C124	393142217	220 μ F16V. ELECT.
	2213580	RN2203	C203-C206	393184797	0.47 μ F50V. ELECT.
Q403, Q404	2213285 or	2SC1740S-S or	C207	393142207	22 μ F16V. ELECT.
	2213284	2SC1740S-R	C213, C214	393180227	2.2 μ F50V. ELECT.
Q407	221281 or	DTC114YS or	C217-C220	393181097	0.1 μ 50V. ELECT.
	2213570	RN1207	C221, C222	393180227	2.2 μ F50V. ELECT.
Q408	2212855 or	2SB1068-U or	C401, C402	393180107	1 μ F50V. ELECT.
	2212853	2SB1068-K	C404-C406	393180227	2.2 μ F50V. ELECT.
Q409	2211706	2SD655-F	C407	393122217	220 μ F6.3V. ELECT.
Q411, Q412	2211544	2SC1959-Y	C408	393144707	47 μ F16V. ELECT.
Q415, Q416	221281 or	DTC114YS or	C411	370131234	0.012 μ F100V. APS
	2213570	RN1207	C421	370131014	100PF100V. APS
Q601	221281 or	DTC114YS or	C427	393144707	47 μ F16V. ELECT.
	2213570	RN1207	C601	393180477	4.7 μ F50V. ELECT.
Q602	2213355 or	2SA933S-S or	C604	393184797	0.47 μ F50V. ELECT.
	2213354	2SA933S-R	C701	393142207	22 μ F16V. ELECT.
Q603, Q604	2211706	2SD655-F	C703	393141017	100 μ F16V. ELECT.
Q703, Q704	221281 or	DTC114YS or	C704	393184797	0.47 μ F50V. ELECT.
	2213570	RN1207	C707	393141017	100 μ F16V. ELECT.
Q705	2211945 or	2SK246-GR or	C708	393184797	0.47 μ F50V. ELECT.
	2212304	2SK381-D	C711	393180107	1 μ F50V. ELECT.
Q706	2212600 or	DTA124ES or	C714, C715	393184797	0.47 μ F50V. ELECT.
	2213580	RN2203	C901	3500065A	0.01 μ F AC400V. IS.
Q707, Q708	2211706	2SD655-F	C903	393152227S	2200 μ F25V. ELECT.
Q709	2211255	2SC1815-GR	C904	393142217	220 μ F16V. ELECT.
Q711, Q712	221281 or	DTC114YS or	C906	393152227S	2200 μ F25V. ELECT.
	2213570	RN1207	C907	393142217	220 μ F16V. ELECT.
Q713	2211945 or	2SK246-GR or	C909	393156827S	6800 μ F25V. ELECT.
	2212304	2SK381-D	C910	393180107	1 μ F50V. ELECT.
Q714	2212600 or	DTA124ES or	C911	393142217	220 μ F16V. ELECT.
	2213580	RN2203	C913-C915	393141017	100 μ F16V. ELECT.
Q715, Q716	2211706	2SD655-F	C916	393180477	4.7 μ F50V. ELECT.
Q717	2211255	2SC1815-GR	C917	393144717	470 μ F16V. ELECT.
Q718, Q719	2212600 or	DTA124ES or	C919	393144717	470 μ F16V. ELECT.
	2213580	RN2203	C921	393142217	220 μ F16V. ELECT.
Q720	2212600 or	DTA124ES or			
	2213580	RN2203			

PRINTED CIRCUIT BOARD PARTS LIST

CIRCUIT NO.	PARTS NO.	DESCRIPTION
C923	393142217	220 μ F16V, ELECT.
C925, C926	393141017	100 μ F16V, ELECT.
C927	393141017	100 μ F16V, ELECT.
C929, C933	393141017	100 μ F16V, ELECT.
C931, C932	393141007	10 μ F16V, ELECT.
Resistors		
R113, R114	5210220	N06HR50KBD
R131, R132	5210220	N06HR50KBD
R405, R406	5210064	N06HR 103BD
R458	442520104F	RS1/2WBJ 1 Ω
R459	442524704F	RS1/2WBJ 47 Ω
R461	442522214F	RS1/2WBJ 220 Ω
R472	442523304F	RS1/2WBJ 33 Ω
R473, R474	5210064	N06HR10KBD
R724	442524704F	RS1/2WBJ 47 Ω
R728	5210218	N06HR20KBD
R731	5210217	N06HR10KBD
R743	442524704F	RS1/2WBJ 47 Ω
R747	5210218	N06HR20KBD
R750	5210217	N06HR10KBD
R903	441622704F	RS1/2WBJ 27 Ω
R905, R906	442520224F	RS1/2WBJ 2.2 Ω
R911, R912	442522704F	RS1/2WBJ 27 Ω
Switch		
S901	25035558	NPS-111-L520P
Plug		
P101	25055133	NPLG-3P117
P102	25055136	NPLG-6P120
P201	25045329 or 25045338	NPLJ-4PDBL183 or NPJ-4PDBL189
P401	25055132	NPLG-2P116
P701	25045330	NPJ-2PDBL184
Socket		
P702A	2000991	NSAS-14P943
P703A	2000992	NSAS-6P944
P704A	2000990	NSAS-6P942
P705A	2000991	NSAS-14P943
P706A	2000992	NSAS-6P944
P707A	2002391210	NSAS-12P0235
Miscellaneous		
	27160211-1	RAD-68B, RADIATOR
	27160211	RAD-68, RADIATOR
	27141059	BRACKET
	25060092	NTM-1S33
	82143006	3P+6FN(BC), SCREW

NADIS-4149-4

CIRCUIT NO.	PARTS NO.	DESCRIPTION
lc		
Q303, Q304	222623	IR2E02
LED		
D604	225253A	LS-0241
Capacitors		
C301, C302	353750479S	4.7 μ F25V, ELECT.
C303, C304	353780109S	1 μ F50V, ELECT.
C305	353750479S	4.7 μ F25V, ELECT.
Socket		
P708A	2000985A	NSAS-18P937

NASW-4150-4

CIRCUIT NO.	PARTS NO.	DESCRIPTION
Diode		
D410-D713	223163	ISS133
Switchs		
S201	25065297	NSS-23119, DOLBY
S701-S705	25035548	NPS-111-S510
S706	25065364	NSS-12138, MODE
S707-S715	25035548	NPS-111-S510

NAETC-4151-4

CIRCUIT NO.	PARTS NO.	DESCRIPTION
Variable resistor		
R203, R204	5104214	N09R2L50kA15F
Plug		
P301	25045255	YKBZ1-5009

TAPE MECHNISM PARTS LIST (DECK-B)

REF. NO.	PART NO.	DESCRIPTION
2-1	24602482	IDLER AS
2-2	24601245	REEL MOTOR
2-3	24611565	BASE AS (CHASSIS)
2-4	24602483	BASE AS (REEL)
2-5	24602484	BASE AS (REEL)
2-7	24609032	PAN HEAD SCREW 2.6×6.4Z/N
2-8	24611177	PLASTIC WASHER 1.7×3.2×.25
2-11	24611175	PLASTIC WASHER 2.1×7×.25
3	24611428	R/P HEAD AS
3-5	24611493	BASE (HEAD)
3-9	24605711	SPRING
3-11	833120059	TAPPING SCREW 2×5Z/N
4	24601252	MAIN MOTOR AS
5	24606337	P.C.B. AS (CONTROL)
5-13	24606463	SPU-335-34-FG
5-17	24606271	PUSH SWITCH
7	24607041B	ARM (PROTECT) L
8	24605739	SPRING
9	24611566	SLIDE PLATE
10	24611385	LEAD HOLDER
12	24607116	ARM (PLAY)
14	24602550	CAM GEAR (3R)
15	24603365A	LEVER (REC)
16	24603366	LEVER (PACK)
17	24603367	LEVER (METAL)
18	24602551	MAIN BELT
20	24611041	PLASTIC WASHER 2.6×0.25
23	24610841	PLASTIC WASHER 2.6×4.7×.5
25	24605790	SPRING (L)
26	24605716	SPRING
29	24602487	FLYWHEEL AS
30	24602545	FLYWHEEL AS
31	24602541	PINCH ROLLER AS (R)
32	24602421C	PINCH ROLLER AS
36	24609001	PAN HEAD SCREW SW2.6×5Z/N
37	24609006A	SCREW
39	8930151	E WASHER 1.5S
40	24609055	WAVE SCREW 3×8
43	24611488	CUSHION (HOLDER)
51	24606333	SOLENOID COIL AS
52	24606332A	CORE
53	24606331	PLANGER
61	24611429	PLATE HOLDER AS
62	833126049	TAP TIGHT SCREW 2.6TTP+4C
63	24611888A	WASHER (OIL SEAL)
64	24610844	WASHER 1.9×5×0.25
65	24611389	PLATE HOLDER AS
66	24603395	EJECT ARM (A)
67	82212004	SCREW 2.0×4Z/N
68	24602404	COUNTER BELT
84	24606515	WIRE CONNECTOR (R/P)

TAPE MECHNISM PARTS LIST (DECK-A)

REF. NO.	PART NO.	DESCRIPTION
2-1	24602482	IDLER AS
2-2	24601245	REEL MOTOR
2-3	24611565	BASE AS (CHASSIS)
2-4	24602483	BASE AS (REEL)
2-5	24602484	BASE AS (REEL)
2-7	24609032	PAN HEAD SCREW 2.6x6.4ZN
2-8	24611177	PLASTIC WASHER 1.7x3.2x.25
2-11	24611175	PLASTIC WASHER 2.1x7x.25
3	24600118	P HEAD AS
3-5	24611493	BASE (HEAD)
3-9	24605711	SPRING
3-11	833120059	TAPPING SCREW 2x5ZN
4	24601252	MAIN MOTOR AS
5	24606334	P.C.B. AS (CONTROL)
5-13	24606463	SPU-335-34-FG
5-17	24606271	PUSH SWITCH
7	24607065B	ARM (PROTECT) R
8	24605739	SPRING
9	24611566	SLIDE PLATE
10	24611385	LEAD HOLDER
12	24607116	ARM (PLAY)
14	24602550	CAM GEAR (3R)
15	24603365A	LEVER (REC)
16	24603369	LEVER (PACK)
18	24602551	MAIN BELT
20	24611041	PLASTIC WASHER 2.6x0.25
23	24610841	PLASTIC WASHER 2.6x4.7x.5
25	24605791	SPRING (R)
26	24605716	SPRING
29	24602487	FLYWHEEL AS
30	24602545	FLYWHEEL AS
31	24602541	PINCH ROLLER AS (R)
32	24602421C	PINCH ROLLER AS
36	24609001	PAN HEAD SCREW SW2.6x5ZN
37	24609006A	SCREW
39	8930151	E WASHER 1.5S
40	24609055	WAVE SCREW 3x8
43	24611488	CUSHION (HOLDER)
51	24606333	SOLENOID COIL AS
52	24606332A	CORE
53	24606331	PLANGER
61	24611447	PLATE HOLDER AS
62	833126049	TAP-TIGHT SCREW 2.6TTP+4C
63	2461188A	WASHER (OIL SEAL)
64	24610844	WASHER 1.9x5x0.25
84	24606514	WIRE CONNECTOR (P/B)

A B C D E F G

SCHEMATIC DIAGRAM (1/2)

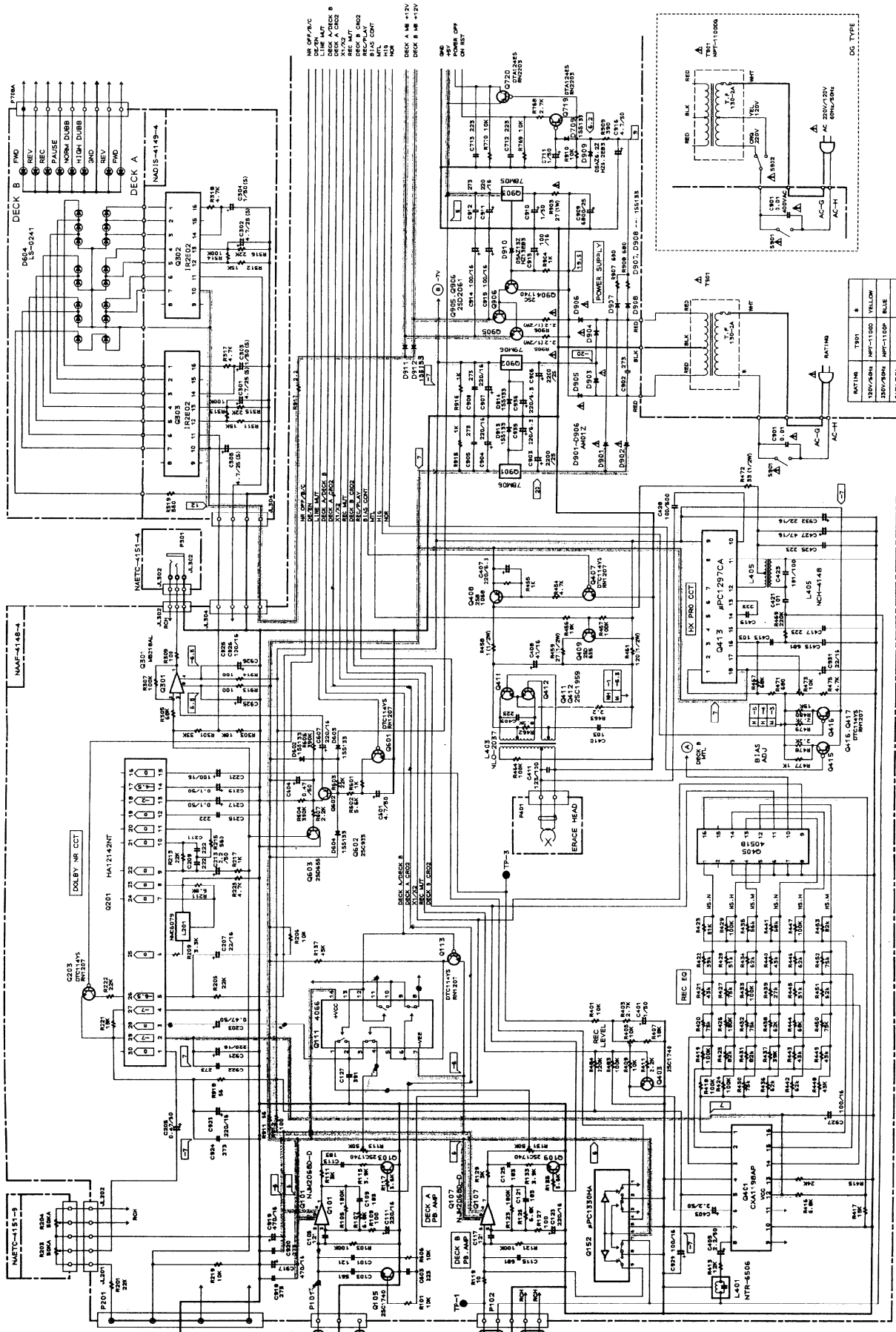

SCHEMATIC DIAGRAM (2/2)

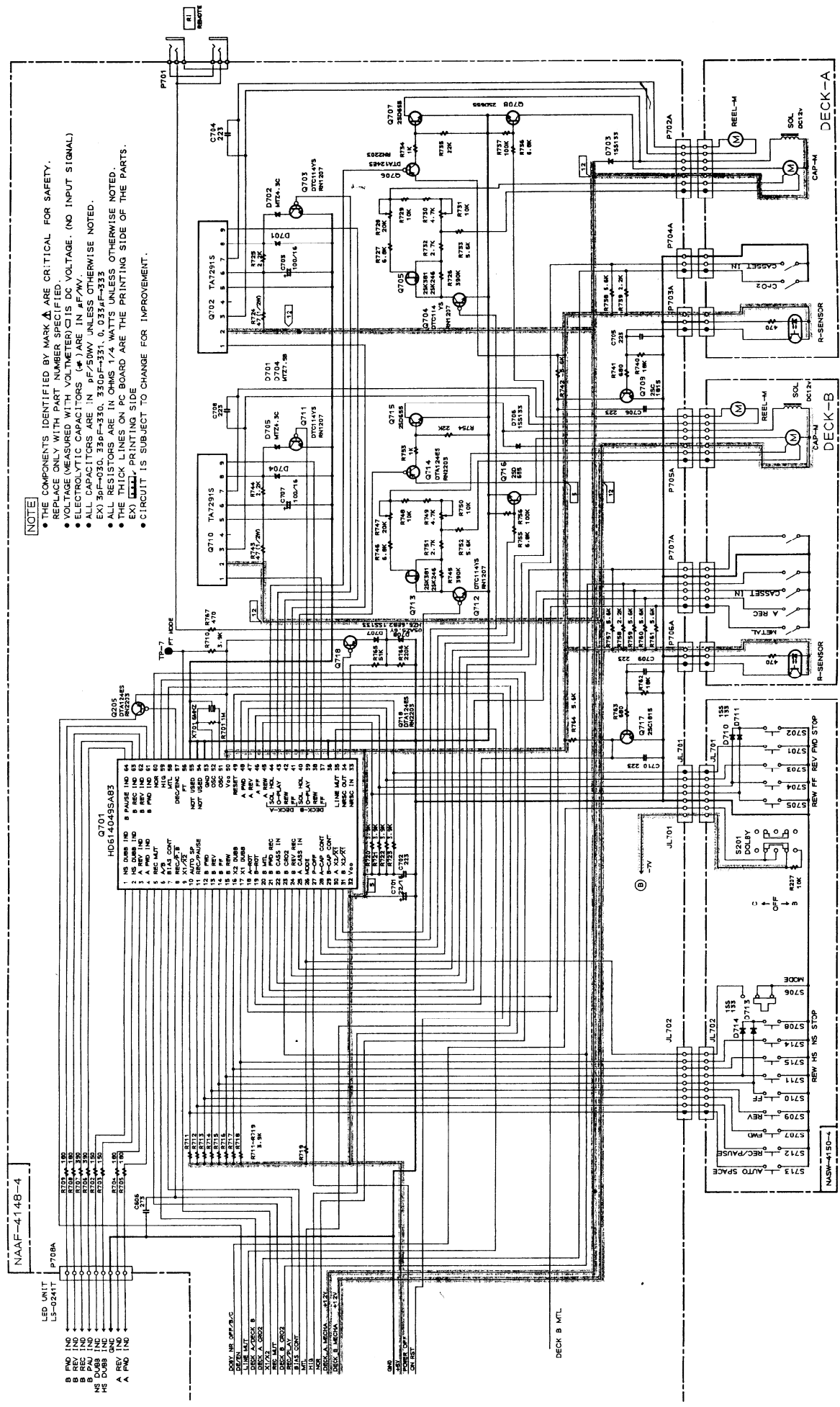

PACKING VIEW

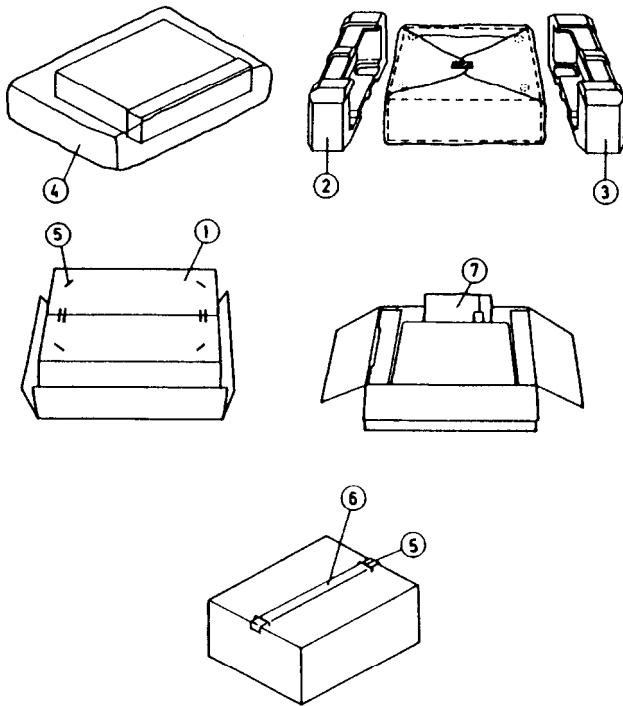

PART LIST

REF. NO.	PART NO.	DESCRIPTION
1	29052557AY	Carton box
2	29091452CY	Pad (L)
3	29091453CY	Pad (R)
4	29100034AY	650×850 Poly bag
5	282301	Sealing hook
6	29110071	Damplon tape
7	Accessory bag ass'y	
	29341801Y	Instruction manual [D]
	29341803Y	Instruction manual [P/W]
	29100097Y	350×250 Poly bag
	2010244Y	Connection cable
	29358002J	S.S. list
	29365019AY	Warranty card [N]
	29365024A	Warranty card [F]
	29100107	Poly bag [F]
	25055040	CV-K-2

NOTE [D]: Only 120V model
 [N]: Only U.S.A. model
 [P]: Only 230V model
 [W]: Only worldwide model
 [F]: Only France model

ONKYO CORPORATION

International Division: 2-1 Nisshin-cho, Neyagawashi, OSAKA, 572, JAPAN

Tel: 0720-31-8133 Fax: 0720-34-1340

ONKYO U.S.A. CORPORATION

200 Williams Drive, Ramsey, N.J. 07446, U.S.A. Tel: 201-825-7950 Fax: 201-825-8150

ONKYO EUROPE

Immeuble Le DIAMANT, Domaine Technologique De Saclay, 4 rue Rene Razel, 91892 SACLAY,

FRANCE Tel: (1)69 33 14 15 FAX: (1)69 41 29 66

ONKYO FRANCE

Immeuble Le DIAMANT, Domaine Technologique De Saclay, 4 rue Rene Razel, 91892 SACLAY,

FRANCE Tel: (1)69 33 14 00 FAX: (1)69 41 35 84