

ONKYO® SERVICE MANUAL

STEREO CASSETTE TAPE DECK

MODEL TA-RW344



Black model

BMD	120V AC, 60Hz
-----	---------------

SPECIFICATIONS

Track Format:	4-track, 2-channels
Erasure System:	AC erase
Tape Speed:	4.8 cm/sec. (1-7/8 i.p.s.) 9.6 cm/sec. (3-3/4 i.p.s.) (high-speed dubbing)
Wow and Flutter:	0.07 % (WRMS)
Frequency Response:	20 — 15,000 Hz (Normal) (30 — 14,000 Hz ± 3 dB) 20 — 16,000 Hz (High) (30 — 15,000 Hz ± 3 dB) 20 — 17,000 Hz (Metal) (30 — 16,000 Hz ± 3 dB)
S/N Ratio:	Dolby NR off: 58 dB (metal position tape) A noise reduction of 10 dB above 5 kHz and 5 dB at 1 kHz is possible with Dolby B NR. A noise reduction of 20 dB at 5 kHz is possible with Dolby C NR.
Input Jacks:	Line IN: 2 Input sensitivity: 80 mV Input impedance: 50 kohms
Outputs:	Line OUT: 2 Standard output level: 500 mV (0 dB) Optimum load impedance: over 50 kohms
Headphone jack:	1 Optimum load impedance: 8 to 200 ohms
Motors:	DC servo motor × 2, DC motor × 2
Heads:	REC/PB: 1 PB: 1 ERASE: 1
Power Supply:	European and Australian models: AC 230V, 50 Hz U.S.A. and Canadian models: AC 120V, 60 Hz Worldwide model: AC 120V and AC 220V, Switchable 50/60 Hz
Power Consumption:	29 watts
Dimensions:	435(W) × 121(H) × 305(D) mm (17-1/8" × 4-3/4" × 12")
Weight:	5.9 kg. (13.0 lbs.)

Specifications and external appearance are subject to change without notice because of product improvements.

SAFETY-RELATED COMPONENT WARNING!!

COMPONENTS IDENTIFIED BY MARK  ON THE SCHEMATIC DIAGRAM AND IN THE PARTS LIST ARE CRITICAL FOR RISK OF FIRE AND ELECTRIC SHOCK. REPLACE THESE COMPONENTS WITH ONKYO PARTS WHOSE PART NUMBERS APPEAR AS SHOWN IN THIS MANUAL.

MAKE LEAKAGE-CURRENT OR RESISTANCE MEASUREMENTS TO DETERMINE THAT EXPOSED PARTS ARE ACCEPTABLY INSULATED FROM THE SUPPLY CIRCUIT BEFORE RETURNING THE APPLIANCE TO THE CUSTOMER.

ONKYO®
AUDIO COMPONENTS

BLOCK DIAGRAM

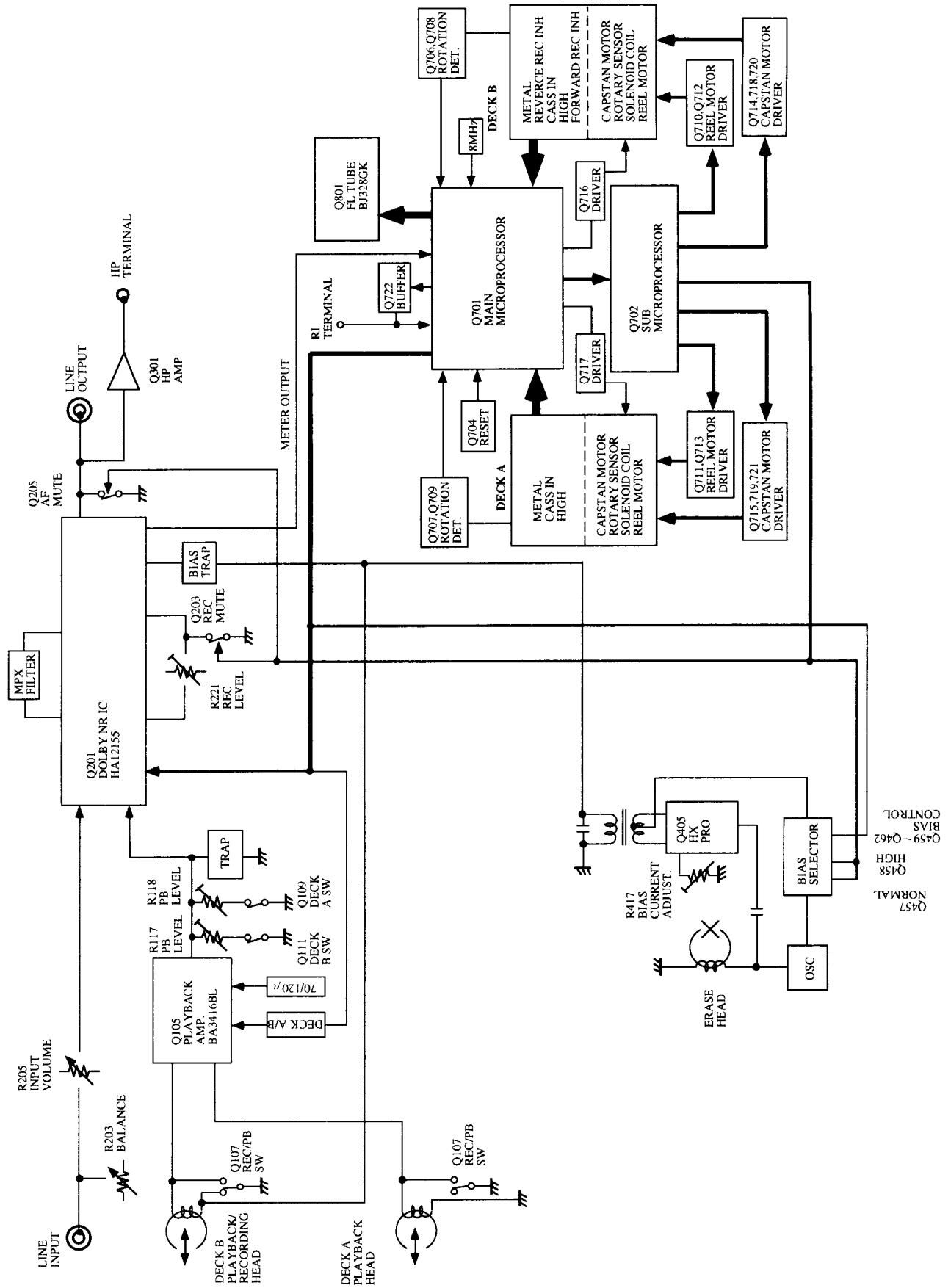

PARTS LIST

REF.NO.	PART NO.	DESCRIPTION	REF. NO.	PART NO.	DESCRIPTION
1	27110955Y	Front bracket ass'y	P101a	2009990350ULY	NSAS-6P0487,Socket for deck A
5	28400282	Damper	P102a	2009990315ULY	NSAS-14P0449,Socket for deck B
7	27180477A	Spring A	P902	253192HIT	AS-UC-6#18,Power supply cord
10	27130741Y	Bracket F	T901	2301049Y	NPT-1223D,Power transformer
13	27301792AY	Cassette frame	U1	1N262586-5Y	NAAR-5086-5,Main circuit pc board ass'y
14	27180435	Spring	U2	1N262587-5Y	NAPS-5087-5,Power supply pc board ass'y
16	28324943Y	Knob,eject	U3	1N262588-5Y	NAETC-5088-5,Input level volume pc board ass'y
18	27100322Y	Chassis	U4	1N262589-5Y	NAETC-5089-5,Headphone terminal pc board ass'y
21	27122273AY	Rear panel	U5	1N262593-5Y	NADIS-5093-5,Display circuit pc board ass'y
22	27300750	△ Cord bushing	W701	2047291512Y	NCFC-291512,Flat cable
25	830440089	4TTC+8C(BC),Self-tapping screw	Z1	244196Y	NDM-187,Deck mechanism ass'y
26	838130088	3TTB+8B,Self-tapping screw	Z2	244197Y	NDM-188,Deck mechanism ass'y
27	833430088	3TTB+8B(BC),Self-tapping screw			
29	838130088	3TTB+8B,Self-tapping screw			
31	27190480-1Y	PCB-8L,Holder			
36	28184664Y	Top cover			
38	838430088	3TTB+8B(BC),Self-tapping screw			
51	27211867Y	Front panel			
57	28135244Y	Badge			
61	28191754Y	Clear plate			
62	27301909Y	Cassette lid A			
63	27301910Y	Cassette lid B			
64	28400625Y	Window			
66	28323671A	Knob, Volume			
67	28325453Y	Knob, Power			
68	27273135BY	Joint			
71	27175316AY	Leg			
71a	28141332Y	Cushion,for leg			
72	838130088	3TTB+8B,Self-tapping screw			
73	835430068	3TTF+6B(BC),Self-tapping screw			
91	260208	Wire tie			

NOTE: THE COMPONENTS IDENTIFIED BY MARK △ ARE CRITICAL FOR RISK OF FIRE AND ELECTRIC SHOCK. REPLACE ONLY WITH PART NUMBER SPECIFIED.

ADJUSTMENT PROCEDURES

PRECAUTIONS

1. Before adjustment, clean the following parts with an alcohol moistend swab.

* record/playback head	* erase head
* pinch roller	* capstan
2. Do not use magnetized screwdriver for adjustments.
3. Demagnetize record/playback head with a liead demagnetizer.

TEST EQUIPMENT / TOOLS REQUIRED:

Audio oscillator
Digital frequency counter
Oscilloscope
Attenuator
AC voltmeter
Non-magnetic screwdriver
Test tapes
TCC-153 :10kHz, -15dB
MTT-111 :3kHz, -10dB
MTT-150 :Dolby level calibration
 400Hz, tone 200nWb/m

Tape speed adjustment

Connect the digital frequency counter to the line output terminal.

Load the test tape MTT-111 into the cassette holder.

Connect the test point J285 to the ground to be unit to the adjustment mode.

Press the forward play button twice to be unit to the high speed.

Adjust the trim resistors R755(Deck A) and R754(Deck B) so that the frequency counter reading becomes 6000Hz to 6020Hz.

Press the forward play button to be unit to the normal speed.

Adjust the trim resistors R751(Deck A) and R750(Deck B) so that the frequency counter reading becomes 3000Hz to 3010Hz.

Item	Connection of instrument	Line input	Test tape	Mode	Output indicator	Adjustment point	Adjust for	Remarks
Head azimuth	AC voltmeter and oscilloscope to output terminal		TCC-153	Playback	AC voltmeter and Oscilloscope	Head azimuth screw Foward:Left side Reverse:Right side	Maximum and same separation at left and right channels.	Figure 1
Playback level	AC voltmeter to test point P202		MTT-150	Playback	AC voltmeter	Deck A R119(Left channel) R120(Right channel) Deck B R117(Left channel) R118(Right channel)	300mV	
Oscillator block	Frequency counter to test point P401		Metal tape XS-C90	Stop	Frequency counter	L401	107 ± 2kHz	Test mode When you press the stop key, deck becomes recording mode of metal position. Test mode
Bias current	Figure 2	1kHz, -23dB and 12kHz, -23dB	UD-1 C-90	Recording/playback	AC voltmeter	R417(Left channel) R418(Right channel)	Difference of 1kHz and 12kHz become less than 1dB.	When you press the AUTO SPACE key, recording of deck starts. Next when you press the AUTO SPACE key, rewind to recording start point and starts to playback.
Recording level	Figure 2	1kHz 350mV	UD-1 C-90	Recording	AC voltmeter	Attenuator	350mV	When you press the AUTO SPACE key, recording of deck starts. Next when you press the AUTO SPACE key, rewind to recording start point and starts to playback.
				Recording/playback	AC voltmeter	R221(Left channel) R222(Right channel)	Signals of recording and playback become same level	

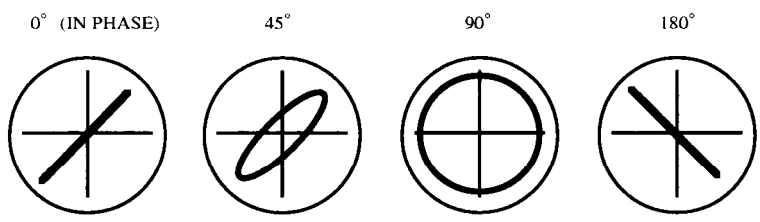
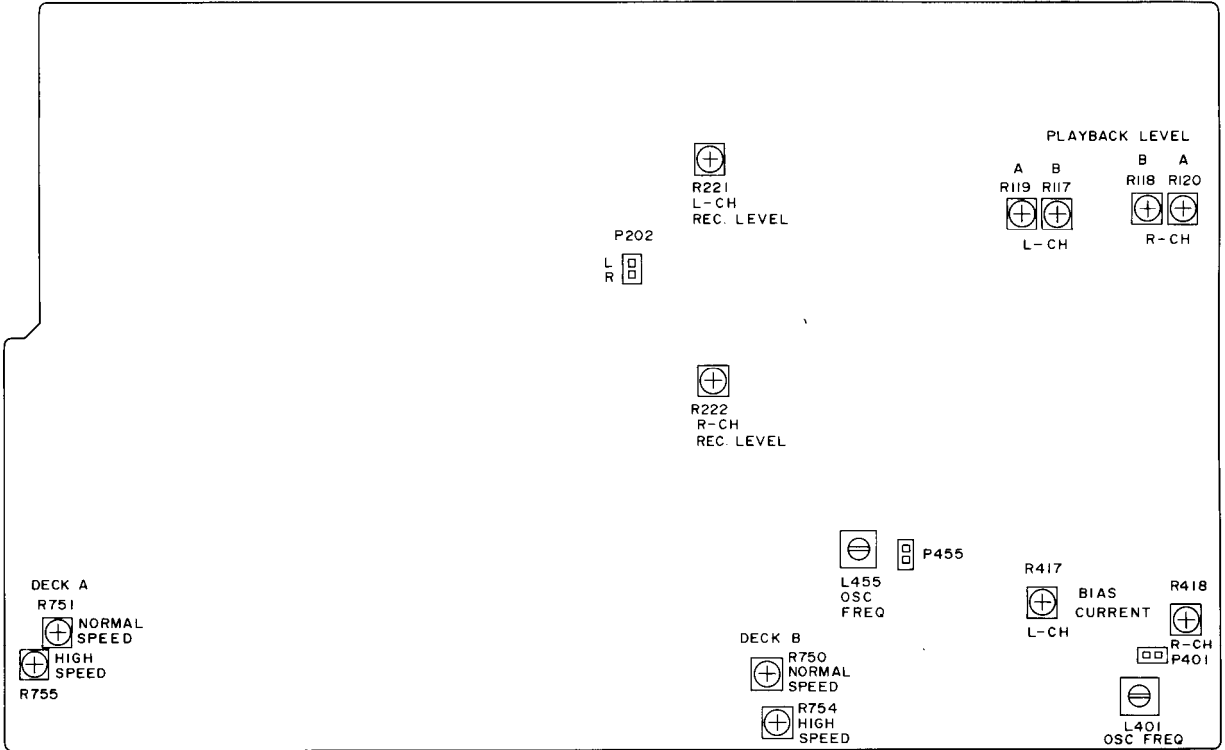

Confirming phase relationship
Fig.1

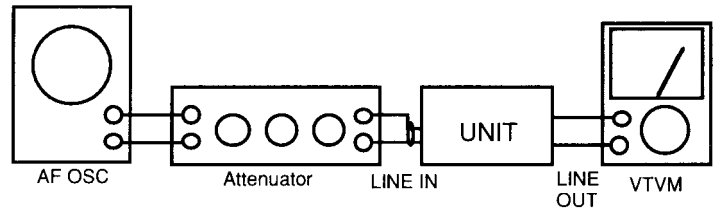

Fig. 2

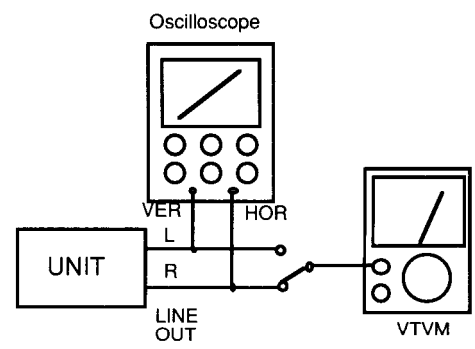
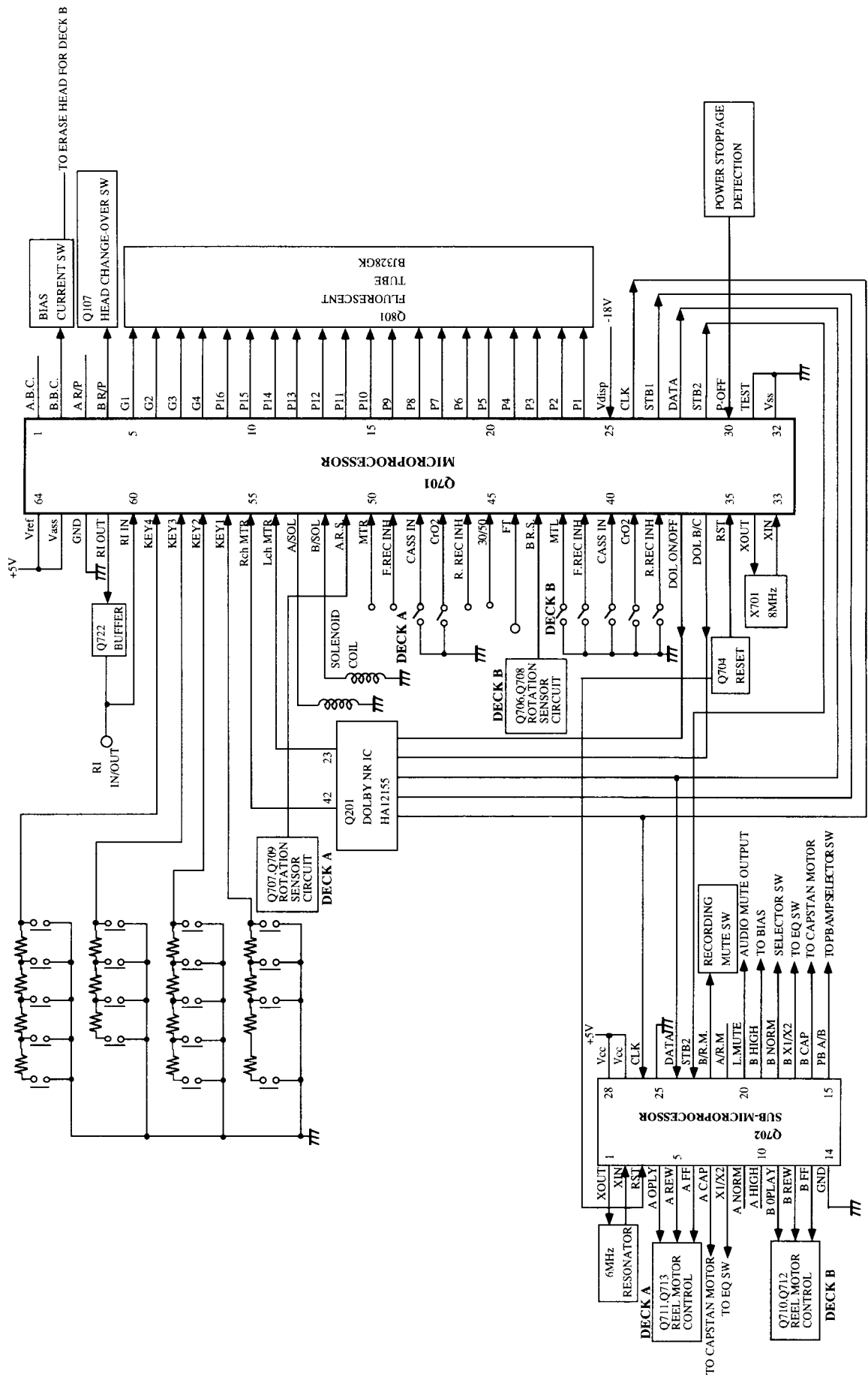

Fig.3

MICROPROCESSOR-CONNECTION DIAGRAM



MICROPROCESSOR-TERMINAL DESCRIPTIONS

MAIN MICROPROCESSOR

Pin No.	Terminal	Description
1	A B.C.	Bias current change-over control output pin for Deck A
2	B B.C.	Bias current change-over control output pin for Deck B
3	A R/P	Recording/playback head change-over output pin for Deck A
4	B R/P	Recording/playback head change-over output pin for Deck B
5	G1	Grid output pin
6	G2	Grid output pin
7	G3	Grid output pin
8	G4	Grid output pin
9	P16	Segment output pin
10	P15	Segment output pin
11	P14	Segment output pin
12	P13	Segment output pin
13	P12	Segment output pin
14	P11	Segment output pin
15	P10	Segment output pin
16	P9	Segment output pin
17	P8	Segment output pin
18	P7	Segment output pin
19	P6	Segment output pin
20	P5	Segment output pin
21	P4	Segment output pin
22	P3	Segment output pin
23	P2	Segment output pin
24	P1	Segment output pin
25	Vdisp	
26	CLK	Clock output pin
27	STB1	Strobe output pin
28	DATA	Data output pin
29	STB2	Strobe output pin.
30	P-OFF	Detection input pin for stoppage of electric current
31	TEST	Test pin
32	Vss	Power supply terminal

Pin No.	Terminal	Description
33	XIN	Ceramic resonator connection pin
34	XOUT	Ceramic resonator connection pin
35	RST	Reset input
36	DOL B/C	Dolby B/C change-over output pin
37	DOL ON/OFF	Dolby change-over output pin
38	R.REC INH	Recording inhibiting detection input pin for reverse side of Deck B.
39	CrO2	High position detection input pin for reverse side of Deck B.
40	CASS IN	Cassette tape detection input pin for reverse side of Deck B.
41	F.REC INH	Recording inhibiting detection input pin for forward side of Deck B.
42	MTL	Metal position detection input pin for reverse side of Deck B.
43	B R.S.	Rotation detection input pin for reel stand of Deck B.
44	FT	Adjustment mode input pin
45	30/50	Initializing input
46	R.REC INH	Recording inhibiting detection input pin for reverse side of Deck A.
47	CrO2	High position detection input pin for reverse side of Deck A.
48	CASS IN	Cassette tape detection input pin for reverse side of Deck A.
49	F.REC INH	Recording inhibiting detection input pin for forward side of Deck A.
50	MTL	Metal position detection input pin for reverse side of Deck A.
51	A. R.S.	Rotation detection input pin for reel stand of Deck A.
52	B/SOL	Solenoid coil drive output pin of Deck B
53	A/SOL	Solenoid coil drive output pin of Deck A
54	Lch mot	Input pin for level meter of left channel
55	Rch mot	Input pin for level meter of right channel
56	KEY1	Operation key connection pin
57	KEY2	Operation key connection pin
58	KEY3	Operation key connection pin
59	KEY4	Operation key connection pin
60	RI IN	Bus signal input pin
61	RI OUT	Bus signal output pin
62	GND	Ground terminal
63	Vass	Power supply pin
64	Vref	Power supply pin

SUB-MICROPROCESSOR

Pin No.	Function	Description
1	XOUT	Ceramic resonator connection pins
2	XIN	Connect the 6.0MHz ceramic resonator.
3	RST	System reset input pin
4	A OPLY	Reel motor control output pin for Deck A
5	A REW	Rewind control output pin for Deck A
6	A FF	Fast forward control output pin for Deck A
7	A CAP	Capstan motor control output pin for Deck A
8	A X1/X2	Capstan motor rotation speed control output for deck A
9	A NORM	Recording equalizer and bias current selector output pin for deck A
10	A HIGH	Recording equalizer and bias current selector output pin for deck A
11	B OPLY	Reel motor control output pin for Deck B
12	B REW	Rewind control output pin for Deck B
13	B FF	Fast forward control output pin for Deck B
14	GND	Ground pin
15	PB A/B	Playback amplifier selector pin
16	B CAP	Capstan motor control output pin for Deck B
17	B X1/X2	Capstan motor rotation speed control output for deck B
18	B NORM	Recording equalizer and bias current selector output pin for deck B
19	B HIGH	Recording equalizer and bias current selector output pin for deck B
20	L.MUTE	Audio muting control output pin
21	A/R.M.A.	Recording muting control pin for deck A
22	B/R.M.	Recording muting control pin for deck B
23	STB2	Strobe input pin
24	DATA	Data input pin
25		
26	CLK	Clock input pin
27	Vcc	Power supply pin
28	Vcc	Power supply pin

TA-7291S (MOTOR DRIVE)

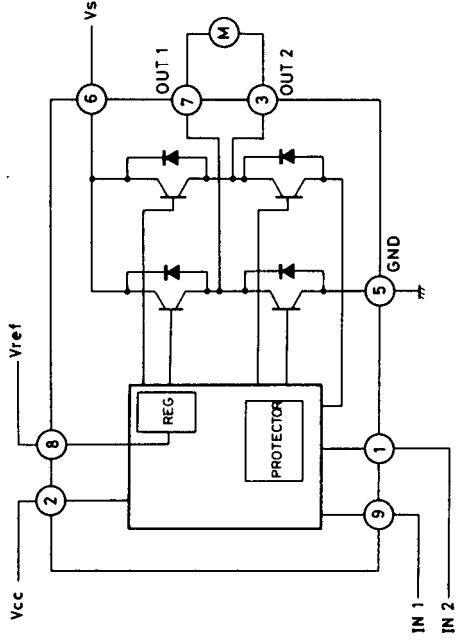

INPUT	OUTPUT		MODE		
	IN 1	IN 2		OUT 1	OUT 2
0	0	∞	∞	∞	STOP
1	0	H	L	L	CW/CCW
0	1	L	H	H	CCW/CW
1	1	L	L	L	BRAKE

A B C D E F G

SCHEMATIC DIAGRAM

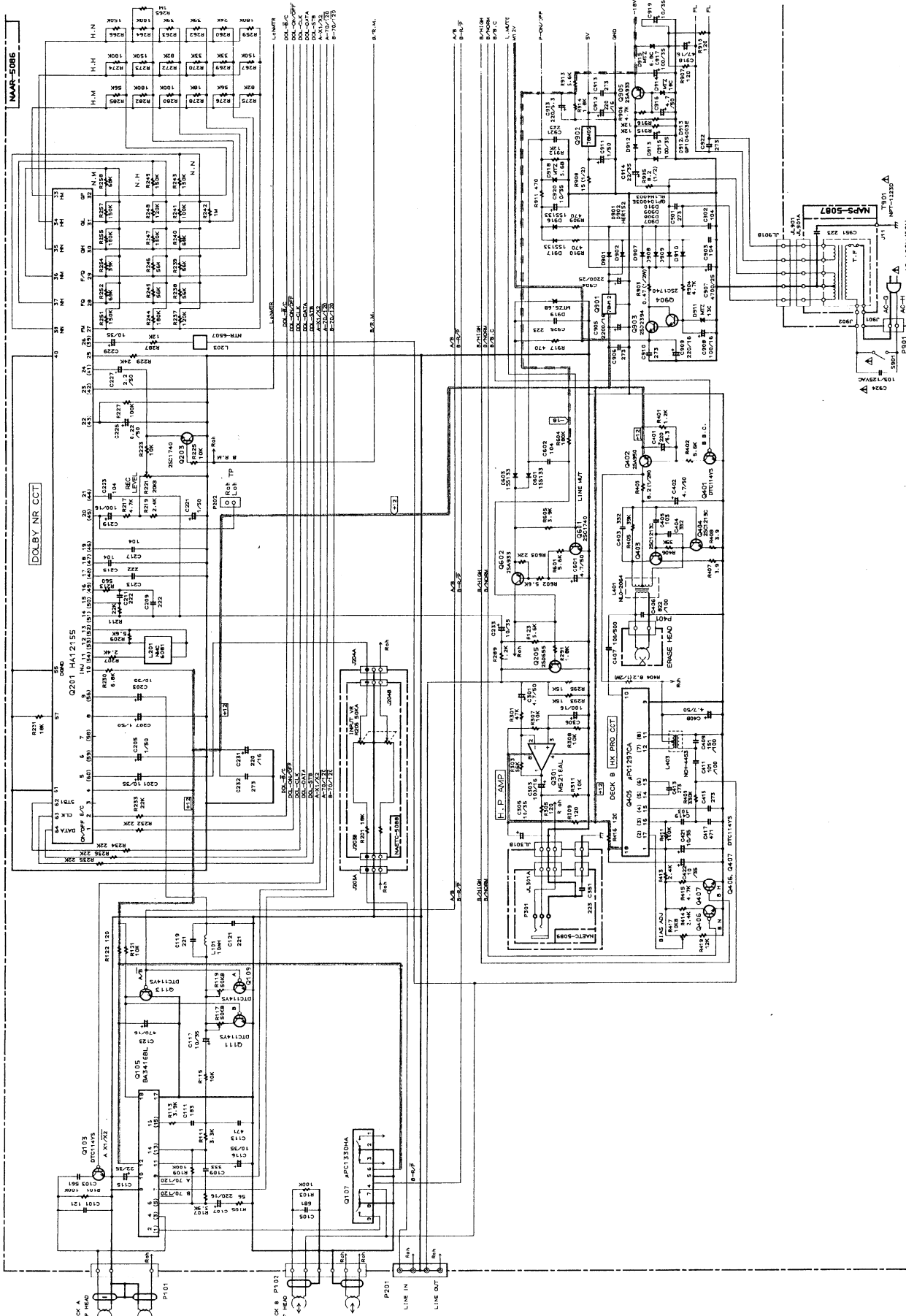

SCHEMATIC DIAGRAM

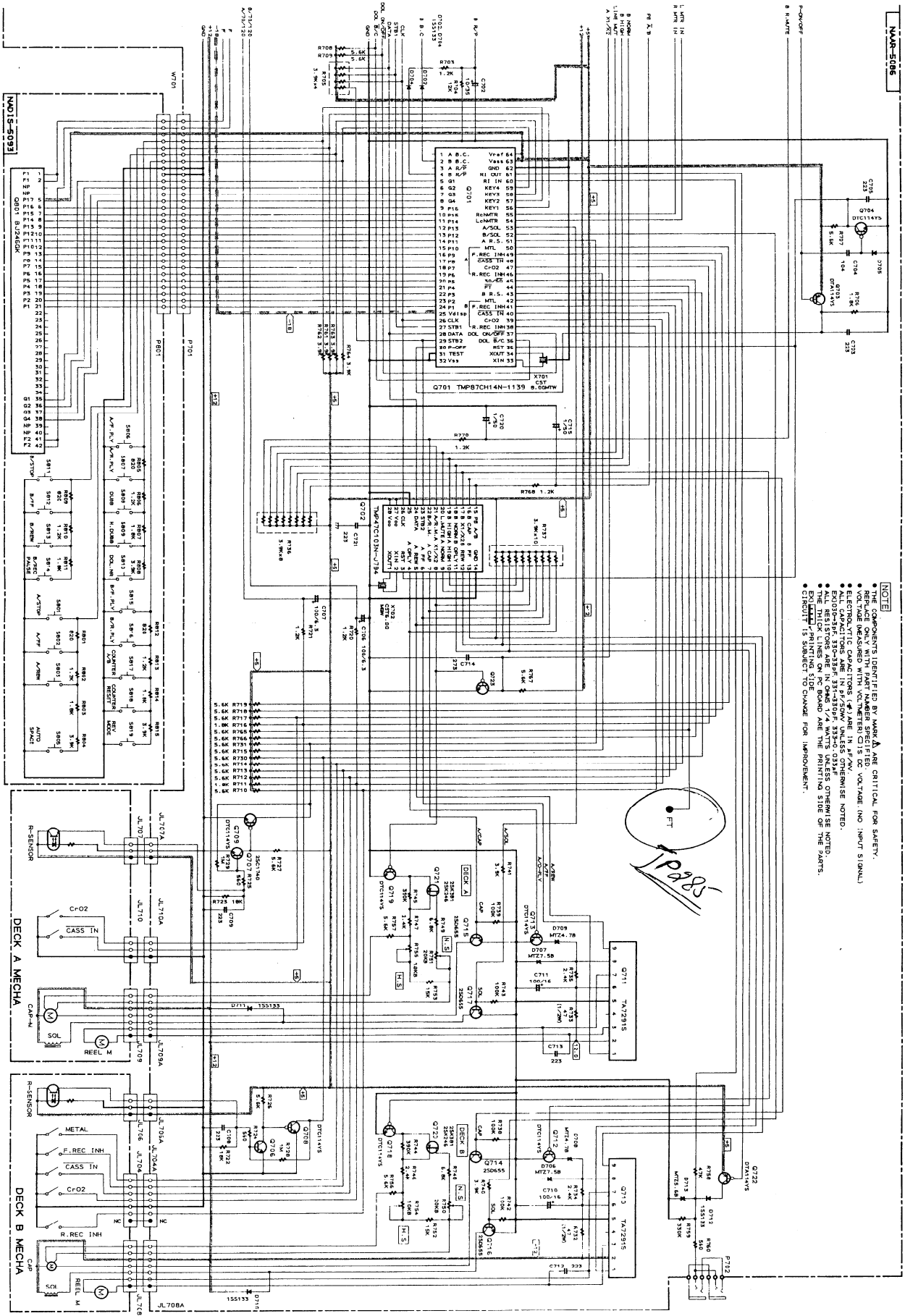

NOTE

- THE COMPONENTS IDENTIFIED BY MARK A ARE CRITICAL FOR SAFETY.
- VOLTAGE MEASURED WITH VOLTMETER @ 15 DC VOLTAGE (NO INPUT SIGNAL).
- ELECTROLYTIC CAPACITORS (E) ARE IN μF/V.
- ALL CAPACITORS ARE IN P.P.S.W. UNLESS OTHERWISE NOTED.
- ALL RESISTORS ARE IN OHMS 1/4 WATT UNLESS OTHERWISE NOTED.
- THE FOLLOWING DIMENSIONS ON PCB BOARD ARE THE PRINTING SIDE OF THE PARTS.
- CIRCUIT IS SUBJECT TO CHANGE FOR IMPROVEMENT.

PRINTED CIRCUIT BOARD-PARTS LIST

MAIN CIRCUIT PC BOARD (NAAR-5086-5)

CIRCUIT NO.	PART NO.	DESCRIPTION	CIRCUIT NO.	PART NO.	DESCRIPTION
			D706,D707	224450752	MTZ7.5B, Zener
			D708,D709	224450472	MTZ4.7B, Zener
		ICs	D710-D712	223163	1SS133
Q105	22240767	BA3416BL	D713	224450562	MTZ5.6B, Zener
Q107	22240147	É PC1330HA	D901,D902	22380031	HER152
Q201	22240544	HA12155NT	D907-D910	22380035	GP104003E
Q301	22240369	M5218AP	D911	224451303	MTZ13C, Zener
Q405	222959	É PC1297CA	D912,D913	22380035	GP104003E
Q701	22240822	TMP87CH14N-1139			
Q702	22240823	TMP47C103N-J794			Diodes
Q710,Q711	22240239	TA7291S	D914	224451803	MTZ18C, Zener
Q901	222780125MIT	78M12	D915	224470683	MTZJ6.8C, Zener
Q902	222780055NEC	78M05HF	D916,D917	223163	1SS133
		Transistors	D918,D919	224450562	MTZ5.6B, Zener
Q103,Q104	221281	DTC114YS			Coils
Q109-Q113	221281	DTC114YS	L101,L102	231089	NCH-2137, CHOKE
Q203,Q204	2213284 or	2SC1740S-R or	L201,L202	233436	NMC-6081, MPX
	2213285	2SC1740S-S	L203,L204	231221	NTR-6507, TRAP
Q205,Q206	2211705 or	2SD655-E or	L401	231223Y	NLO-2064, OSC
	2211706	2SD655-F	L403,L404	231218	NCH-4453, CHOKE
Q401	221281	DTC114YS			Resonators
Q402	2211504	2SA950-Y	X701	3010190	CST8.00MTW, Ceramic
Q403,Q404	2201883	2SC1213-C	X702	3010149	CST6.00MGW, Ceramic
Q406,Q407	221281	DTC114YS			Capacitors
Q601	2213284 or	2SC1740S-R or	C103,C104	374725614	560pF±5%,50V,Plastic
Q706,Q707	2213285	2SC1740S-S	C105,C106	374726814	680pF±5%,50V,Plastic
Q602,Q905	2213354 or	2SA933S-R or	C107,C108	354742219	220µ F,16V,Elect.
	2213355	2SA933S-S	C109,C110	374723334	0.033µ F±5%,50V,Plastic
Q703,Q722	2213090	DTA114YS	C111,C112	374721834	0.018µ F±5%,50V,Plastic
Q704	221281	DTC114YS	C115	354762209	22µ F,35V,Elect.
Q708,Q709	221281	DTC114YS	C116-C118	354761009	10µ F,35V,Elect.
Q712,Q713	221281	DTC114YS	C123	354744719	470µ F,16V,Elect.
Q714-Q717	2211705 or	2SD655-E or	C201-C204	354761009	10µ F,35V,Elect.
	2211706	2SD655-F	C205-C207	354780109	1µ F,50V,Elect.
Q718,Q719	221281	DTC114YS	C209-C214	374722224	2200pF±5%,50V,Plastic
Q720,Q721	2211945 or	2SK246-GR or	C215-C218	374721044	0.1µ F±5%,50V,Plastic
	2212304	2SK381-D	C219,C220	354741019	100µ F,16V,Elect.
Q723	221281	DTC114YS	C221,C222	354780109	1µ F,50V,Elect.
Q903	2202705 or	2SD2394-E	C223,C224	374721044	0.1µ F±5%,50V,Plastic
	2202706	2SD2394-F	C225,C226	354782299	0.22µ F,50V,Elect.
Q904	2213285 or	2SC1740S-S or	C227,C228	354780229	2.2µ F,50V,Elect.
	2213284	2SC1740S-R	C229,C230	354761009	10µ F,35V,Elect.
		Diodes	C231	354742219	220µ F,16V,Elect.
D601,D603	223163	1SS133	C232	374722734	0.027µ F±5%,50V,Plastic
D701	223163	1SS133	C233,C234	354761009	10µ F,35V,Elect.
D704,D705	223163	1SS133	C301,C302	354780479	4.7µ F,50V,Elect.

CIRCUIT NO.	PART NO.	DESCRIPTION
C303,C304	354741019	100 μ F,16V,Elect.
C305	354761009	10 μ F,35V,Elect.
C306	354741019	100 μ F,16V,Elect.
C401	354722219	220 μ F,6.3V,Elect.
C402	354780479	4.7 μ F,50V,Elect.
C403,C404	374723324	3300pF \pm 5%,50V,Plastic
C405	374721034	0.01 μ F \pm 5%,50V,Plastic
C406,C478	370138224	8200pF \pm 5%,100V,Plastic
C408	354780479	4.7 μ F,50V,Elect.
C409,C410	370131514	150pF \pm 5%,100V,Plastic
C411,C412	370131014	100pF \pm 5%,100V,Plastic
C413-C416	374722734	0.027 μ F \pm 5%,50V,Plastic
C417,C418	374724714	470pF \pm 5%,50V,Plastic
C419,C420	374721034	0.01 μ F \pm 5%,50V,Plastic
C421,C422	354761009	10 μ F,35V,Elect.

NOTE: THE COMPONENTS IDENTIFIED BY MARK Δ ARE CRITICAL FOR RISK OF FIRE AND ELECTRIC SHOCK. REPLACE ONLY WITH PART NUMBER SPECIFIED.

MECHANISM-EXPLODED VIEW

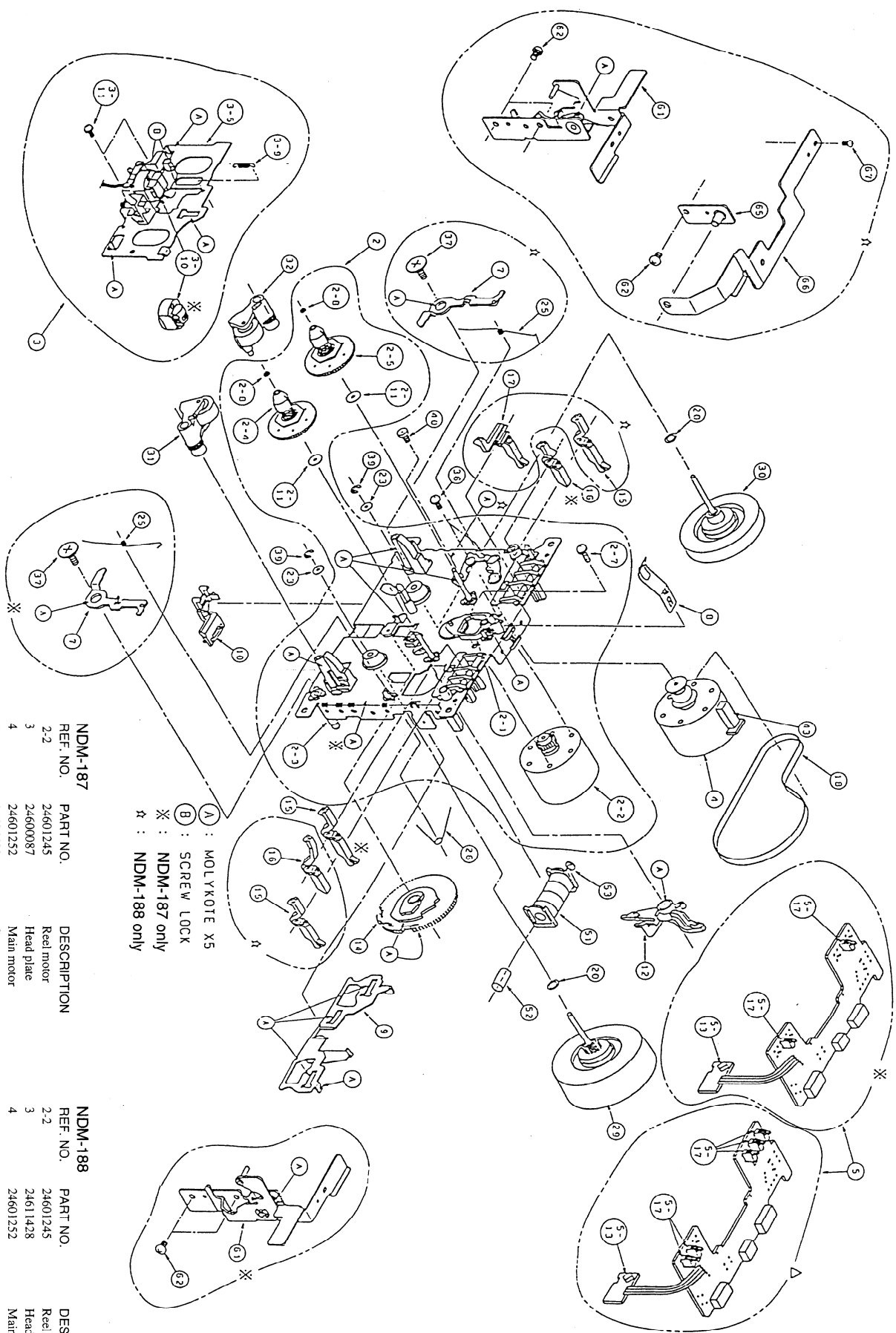

NDM-187
 REF. NO. PART NO. DESCRIPTION

2-2	24601245	Reel motor
3	24600087	Head plate
4	24601252	Main motor
5	24606533	Control pcb
18	24602551	Main belt
31	24602541	Pinch roller R
32	24602589	Pinch roller L

(A) : MOLYKOTE X5
 (B) : SCREW LOCK
 * : NDM-187 only
 † : NDM-188 only

NDM-188
 REF. NO. PART NO. DESCRIPTION

2-2	24601245	Reel motor
3	24611428	Head plate
4	24601252	Main motor
5	24606534	Control pcb
18	24602551	Main belt
31	24602541	Pinch roller R
32	24602589	Pinch roller L

PRINTED CIRCUIT BOARD-PARTS LIST

CIRCUIT NO.	PART NO.	DESCRIPTION	CIRCUIT NO.	PART NO.	DESCRIPTION
	Capacitors				
C482,C601	354780479	4.7μ F,50V,Elect.			Wire traps
C702	354761009	10μ F,35V,Elect.	JL301b	25055624	NPLG-3P586
C704,C602	374721044	0.1μ F±5%,50V,Plastic	JL901b	25050269	NSCT-5P97
C706,C707	354721019	100μ F,6.3V,Elect.			Wire holders
C710,C711	354741019	100μ F,16V,Elect.	JL704a,JL705a	25051101	NSCT-7P888
C715,C720	354780109	1μ F,50V,Elect.	JL706a,JL707a	25051097	NSCT-3P884
C901,C906	374722734	0.027μ F±5%,50V,Plastic.	JL708a,JL709a	25051101	NSCT-7P888
C902,C903	374721044	0.1μ F±5%,50V,Plastic	JL710a	25051097	NSCT-3P884
C904	393352227	2200μ F,25V,Elect.			Terminals
C905	393342227	2200μ F,16V,Elect.	P201	25045329	NPJ-4PDBL183
C907	393354727	4700μ F,25V,Elect.	P702	25045330	NPJ-2PDBL184, RI"
C908,C912	354741019	100μ F,16V,Elect.			Switch
C909	354742219	220μ F,16V,Elect.	S901	25035636	NPS-111-L590P
C910,C913	374722734	0.027μ F±5%,50V,Plastic			
C911	354780109	1μ F,50V,Elect.	POWER SUPPLY CIRCUIT PC BOARD (NAPS-5087-5)		
C914	354762209	22μ F,35V,Elect.	CIRCUIT NO.	PART NO.	DESCRIPTION
C915,C917	354761019	100μ F,35V,Elect.	JL901a	25051109	NSCT-5P896, Wire holder
C916	354780479	4.7μ F,50V,Elect.			
C918,C923	354744709	47μ F,16V,Elect.	INPUT LEVEL VOLUME PC BOARD (NAETC-5088-5)		
C919,C920	354761009	10μ F,35V,Elect.	CIRCUIT NO.	PART NO.	DESCRIPTION
C922	374722734	0.027μ F±5%,50V,Plastic			Resistor
C924	3500191	DE7150FZ103M, AC400V/125V, IS	R205,R206	5104346Y	N09RGL50KA15F, Variable
	Resistors				
R117-R120	5210265	N06HR50KBC, Trimming	HEADPHONE TERMINAL PC BOARD (NAETC-5089-5)		
R221,R222	5210263	N06HR20KBC, Trimming	CIRCUIT NO.	PART NO.	DESCRIPTION
R403,R404	453530824	8.2Ω±5%,1/2W,Metal	P301	25045255	YKB21-5009, Jack
R417,R418	5210262	N06HR10KBC, Trimming	JL301a	25051087	NSCT-3P874, Wire holder
R705	49163392404	RM1/10IJ, 3.9K×4, Array			
R732,R733	443524704	4Ω±5%,1/2W,Metal oxide	DISPLAY CIRCUIT PC BOARD (NADIS-5093-5)		
R736	49163392408	RM1/10IJ, 3.9K×8, Array	CIRCUIT NO.	PART NO.	DESCRIPTION
R737	49163392410	RM1/10IJ, 3.9K×10, Array			FL tube
R750,R751	5210263	N06HR20KBC, Trimming	Q801	212137	BJ328GK
R754,R755	5210262	N06HR10KBC, Trimming			Switches
R903	453534794	0.47Ω±5%,1/2W,Metal	S801-S803	25035652	NPS-111-S604, P SW
R905	453530824	8.2Ω±5%,1/2W,Metal	S804-S819	25035652	NPS-111-S604, P SW
R908	443521504	15Ω±5%,1/2W,Metal oxide			Socket
	Plugs		P801	25050893	NSCT-29P688
P102	25055136	NPLG-6P120			Holder
P103	25055133	NPLG-3P117			27190939Y
P202	25055038	NPLG-2P29			FL
P401	25055132	NPLG-2P116			
P901	25055675	NPLG-2P631			
	Socket				
P701	25050861	NSCT-29P656			

PACKING VIEW

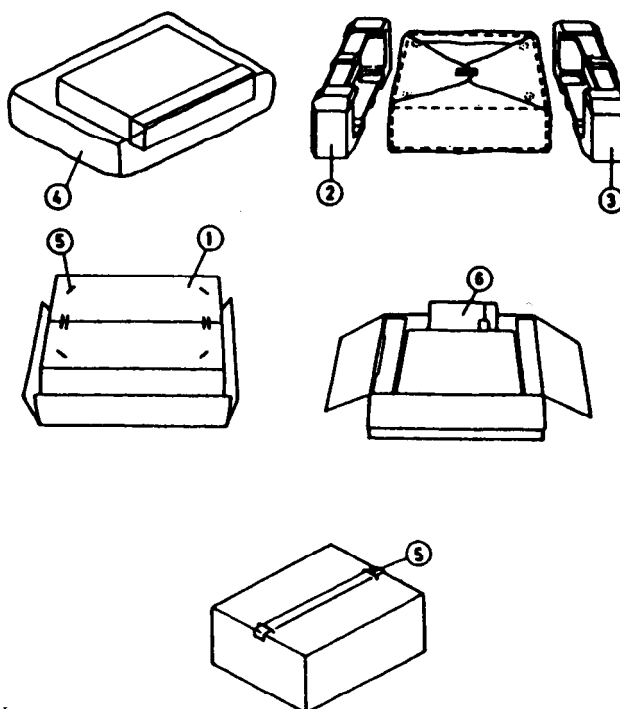

REF.NO.	PART NO.	DESCRIPTION
1	29053106Y	Carton box
2	29091636-1CY	Pad L
3	29091637-1CY	Pad R
4	29100034-1AY	650×850mm, Styren bag
5	282301	Staple
6	Accessory bag ass'y	
	29342382Y	Instruction manual, English
	2010244Y	Connection cord
	29100097-1AY	350×250mm, Styren bag
	29365019B	Warranty card
	29358002K	Service station list
	29362002Y	Label UPC

ONKYO CORPORATION

International Sales Div.: 31 Sankyo-bld. 3-8-5, Asakusabashi, Taito-ku, TOKYO 111, JAPAN
 TEL : 03-5820-5865 FAX : 03-5820-5869

ONKYO U.S.A. CORPORATION
 200 Williams Drive, Ramsey, N.J. 07446, U.S.A.
 TEL : 201-825-7950 FAX : 201-825-8150

ONKYO EUROPE ELECTRONICS GmbH
 Industriestrasse 18-20, 82110 Germering, GERMANY
 TEL : 089 84 93 20 FAX : 089 84 93 226

ONKYO FRANCE
 Immeuble Le Diamant, Domaine Technologique de Saclay, 4 Rue Rene Razel, 91892 SACLAY, FRANCE
 TEL : (1) 69 33 1400 FAX : (1) 69 41 35 84