

ONKYO SERVICE MANUAL

STEREO CASSETTE TAPE DECK MODEL TA-RW414

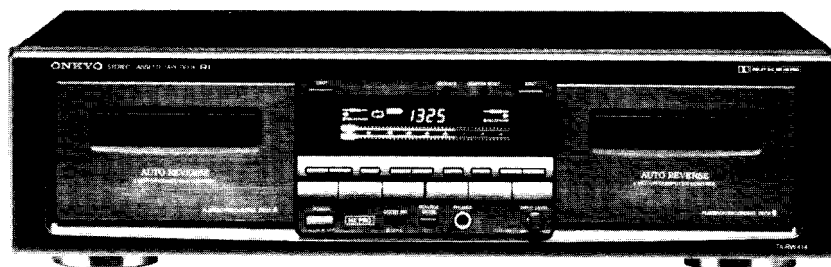

Black and Silver model

UD, UD (N)	120V AC, 60Hz
UP	230V AC, 50Hz
UW	120 or 220V AC, 50/60Hz
UQ	240V AC, 50Hz

SAFETY-RELATED COMPONENT WARNING!!

COMPONENTS IDENTIFIED BY MARK Δ ON THE SCHEMATIC DIAGRAM AND IN THE PARTS LIST ARE CRITICAL FOR RISK OF FIRE AND ELECTRIC SHOCK. REPLACE THESE COMPONENTS WITH ONKYO PARTS WHOSE PART NUMBERS APPEAR AS SHOWN IN THIS MANUAL.

MAKE LEAKAGE-CURRENT OR RESISTANCE MEASUREMENTS TO DETERMINE THAT EXPOSED PARTS ARE ACCEPTABLY INSULATED FROM THE SUPPLY CIRCUIT BEFORE RETURNING THE APPLIANCE TO THE CUSTOMER.

SPECIFICATIONS

Track System:	4-track, 2-channel
Erasing System:	AC erase
Tape Speed:	4.8 cm/sec. (1-7/8 i.p.s.) 9.6 cm/sec. (3-3/4 i.p.s.) (high-speed dubbing)
Wow and Flutter:	0.07% (WRMS)
Frequency Response:	20 – 15,000Hz (Normal) (30 – 14,000Hz \pm 3dB) 20 – 16,000Hz (High) (30 – 15,000Hz \pm 3dB) 20 – 17,000Hz (Metal) (30 – 16,000Hz \pm 3dB)
S/N Ratio:	Dolby NR off: 58dB (metal position tape) A noise reduction of 10dB above 5kHz and 5dB at 1kHz is possible with Dolby B NR. A noise reduction of 20dB at 5kHz is possible with Dolby C NR.
Input Jacks:	Line IN: 2 Input sensitivity: 80mV Input impedance: 50 kohms
Outputs:	Headphone jack: 1 Optimum load impedance: 8 to 200 ohms Line OUT: 2 Standard output level: 500mV (0dB) Optimum load impedance: over 50 kohms
Motors:	DC servo motor x 2; DC motor x 2
Heads:	REC/PB head: 2; Erase head: 2
Power Supply:	<ul style="list-style-type: none"> • European models: AC 230V, 50 Hz • USA and Canadian models: AC 120 V, 60 Hz • Worldwide models: AC 120 and 220 V switchable, 50/60 Hz
Power Consumption:	35 watts
Dimensions:	455(W) x 120(H) x 306(D)mm (17-15/16" x 4-3/4" x 12-1/16")
Weight:	6.0 kg. (13.2 lbs.)

Specifications and external appearance are subject to change without notice because of product improvements.

ONKYO.
AUDIO COMPONENTS

BLOCK DIAGRAM

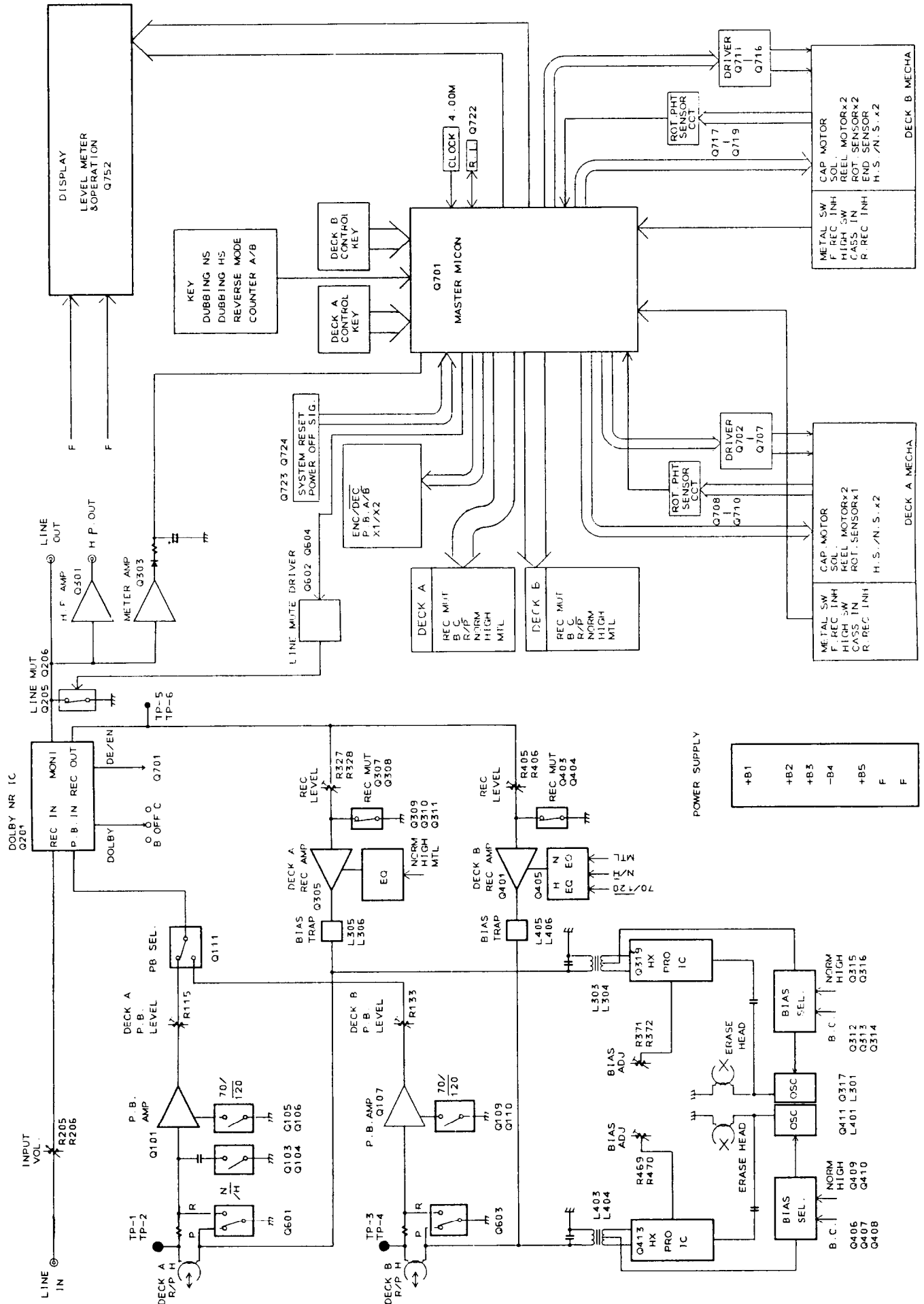

IC BLOCK DIAGRAM

HA12142NT (DOLBY NR)

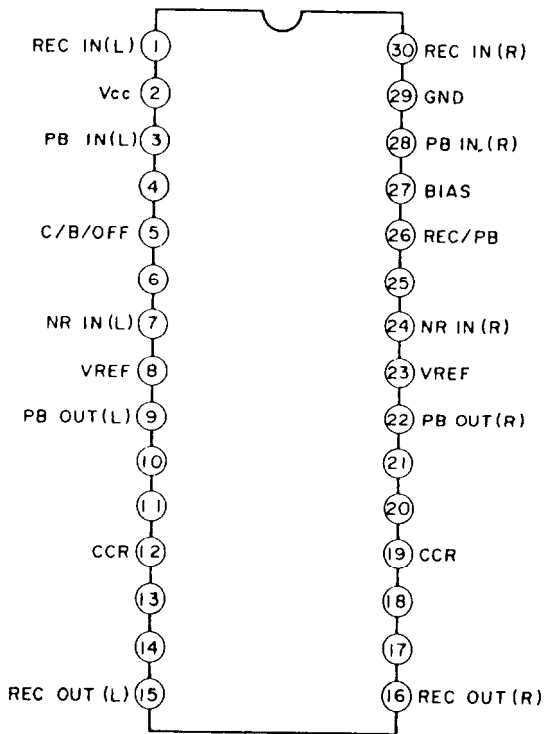

μPC 1330HA (REC/PB SW)

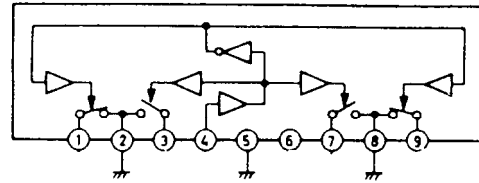

μPC1330HA

Pin No.	Function
1, 9	PB. signal
2	GND
3, 7	REC signal
4	REC/PB SW control
5	GND
6	+B
8	GND

4051B (ANALOG SW)

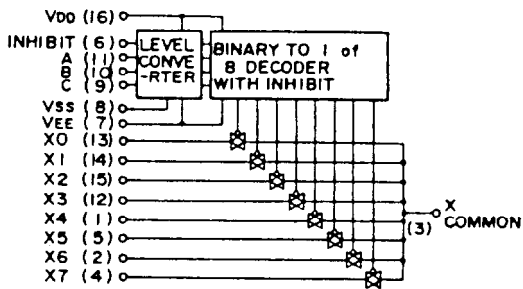

INHIBIT	A(11)	B(10)	C(9)	ON SWITCH
L	L	L	L	X0 (13)
L	H	L	L	X1 (14)
L	L	H	L	X2 (15)
L	H	H	L	X3 (12)
L	L	L	H	X4 (1)
L	H	L	H	X5 (5)
L	L	H	H	X6 (2)
L	H	H	H	X7 (4)
H	X	X	X	NONE

X: Don't Care

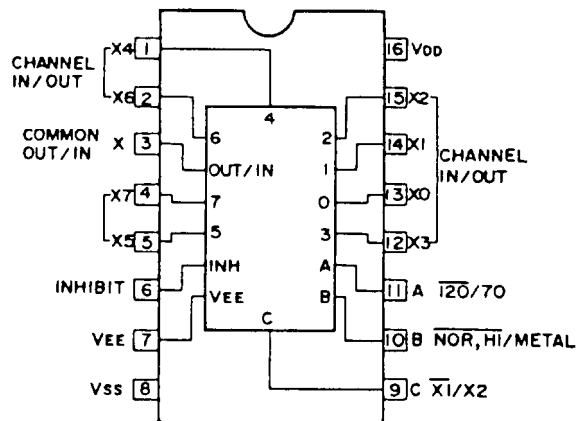

MICROCOMPUTER TERMINAL DESCRIPTION (HD404719A20FS)

Port No.	Name	IN/OUT	Function	Port No.	Name	IN/OUT	Function
1	SEARCH SIG.	IN	Search signal in put	57	T2 SOLENOID	OUT	Solenoid drive
2	P-OFF	IN	Power off detection	58	T2 REEL-REW	OUT	Reel motor rotation control: REW
3	\overline{FT}		Test terminal	59	T2 REEL-FF	OUT	Reel motor rotation control: FF
4	A GND		Analog grand	60	T2 O-PLAY	OUT	Reel motor rotation torque control
5	RESET	IN	System micon reset	61	T1 REV.REC-INH	IN	Recording prevention
6	OSC1		Clock oscillator	62	T1 HIGH IN	IN	High tape deteciton
7	OSC2		Clock oscillator	63	$\overline{T1}$ CASS-IN	IN	Tape lording detection
8	GND			64	T1 FWD.REC-INH	IN	Recording prevention
9			Not use	65	T1 METAL IN	IN	High tape detection
10			Not use	66	T1 ROTATION SEN.	IN	Reel rotation sensor
11	\overline{TEST}			67	T1 CAPSTAN X2/ $\overline{X1}$	IN	Capstan motor high/normal speed control
12	Vcc		+5V	68	T1 CAPSTAN CONT.	OUT	Capstan motor drvie control
13	LINE MUT	OUT	Lime muting, active high	69	T1 SOLENOID	OUT	Solenoid drive
14	DOLBY DEC/ \overline{END}	OUT	Dolby encord/decord selection	70	T1 REEL-REW	OUT	Reel motor rotation control: REW
15	T2 REC. MUTE	OUT	Recording muting, active high	71	T1 REEL-FF	OUT	Reel motor rotation control: FF
16	T1 REC. MUTE	OUT	Recording muting, active high	72	T1 O-PLAY	OUT	Reel motor rotation torque control
17	PB SEL T2/ $\overline{T1}$	OUT	Play back signal selection	73	\overline{NRSC} OUT	OUT	R1 cord out put
18	T2 BIAS CONTROL	OUT	Bias oscillator control	74	NRSC IN	IN	R1 cord in put
19	T1 BIAS CONTROL	OUT	Bias oscillator control	75	A Vcc		
20	TAPE SPEED X1/ $\overline{X2}$	OUT	Tape speed normal/high selection	76 ~ 78	OPERATION KEY IN	IN	Key in put
21	T2 NORMAL	OUT	Normal tape: H	79	L-METER IN	IN	Level meter signal
22	T2 HIGH	OUT	High tape: H	80	R-METER IN	IN	Level meter signal
23	T2 REC/ \overline{PB}	OUT	Recording/play back selection				
24		NC					
25 ~ 28	1G ~ 4G	OUT	Display tube grid drive				
29 ~ 44	P1 ~ P16	OUT	Dispaly tube segement drive				
45	T1 NORMAL	OUT	Normal tape: H				
46	T1 HIGH	OUT	High tape: H				
47	T1 REC/ \overline{PB}	OUT	Recording/play back selection				
48		NC					
49	T2 REV.REC-INH	IN	Recroding prevention				
50	T2 HIGH IN	IN	High tape detection				
51	$\overline{T2}$ CASS-IN	IN	Cassette tape lording detection				
52	T2 FWD.REC-INH	IN	Recording prevention				
53	T2 METAL IN	IN	Metal tape detection				
54	T2 ROTATION SEN.	IN	Reel rotation sensor				
55	T2 CAPSTAN X2/ $\overline{X1}$	OUT	Capstan motor speed control				
56	T2 CAPSTAN CONT.	OUT	Capstan motor drive control				

MICROCOMPUTER

HD404719A20FS

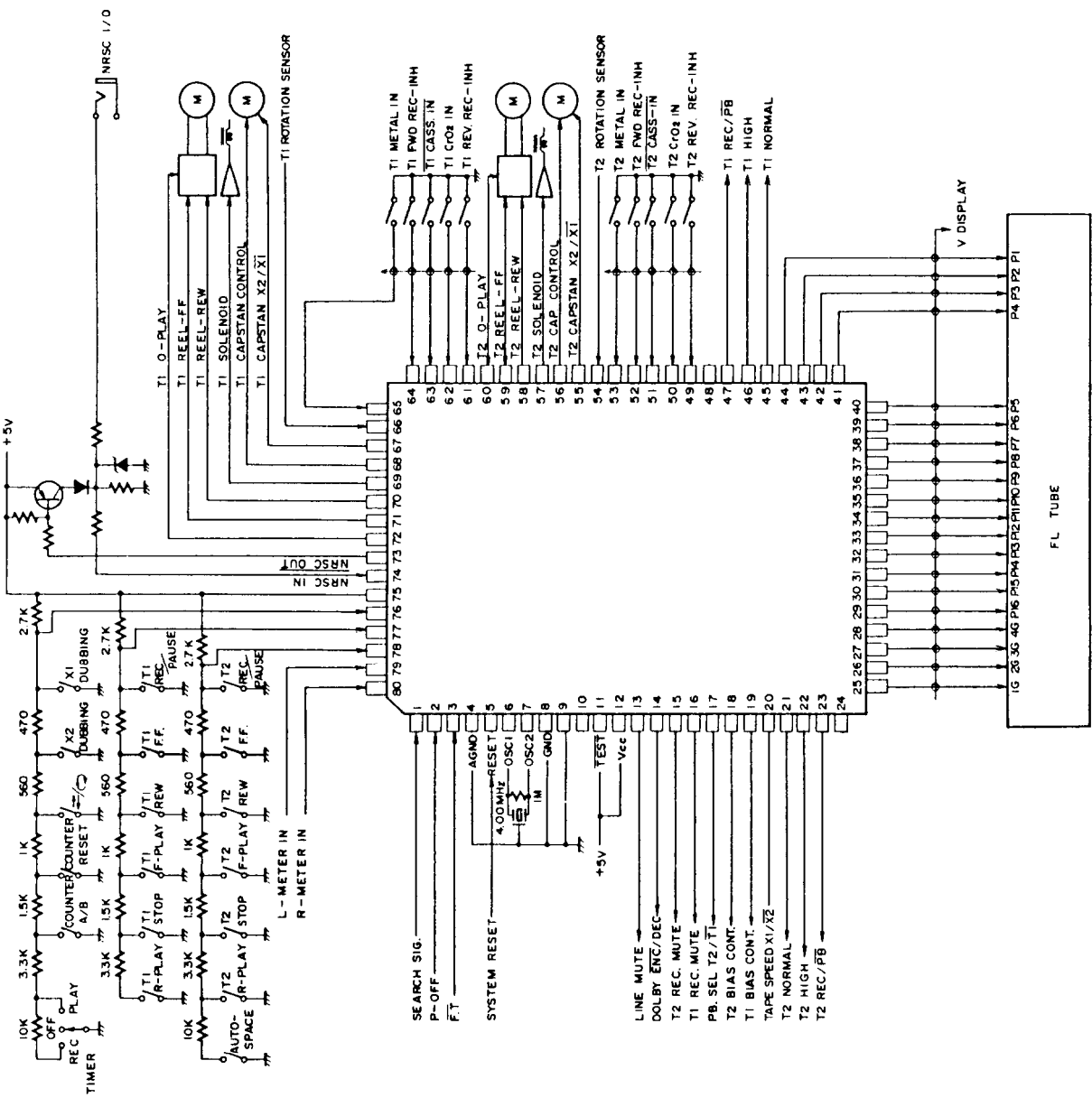

ADJUSTMENT PROCEDURES

PRECAUTIONS

- Before adjustment, clean the following parts with an alcohol moistend swab.
 - * record/playback head
 - * pinch roller
 - * erase head
 - * capstan
- Do not use magnetized screwdriver for adjustments.
- Demagnetize record/playback head with a head de-magnetizer.

TEST EQUIPMENT/TOOLS REQUIRED:

- Audio oscillator
- Digital frequency counter
- Oscilloscope
- Attenuator
- AC voltmeter
- Non-magnetic screw driver
- Test tapes
 - TCC-153 : 10 KHz, - 5dB
 - MTT-111 : 3 kHz, - 0dB
 - MTT-150 : Dolby level calibration
400Hz, tone 200nWb/m

Item	Connection of instrument	Line input	Test tape	Mode	Output indicator	Adjustment point	Adjust	Remarks	
1	Tape speed	Frequency counter to LINE output terminal	MTT-111	PB	Frequency counter	DECK-A High R714 Normal R711 DECK-B High R740 Normal R737	6010±10Hz 3005±5Hz 6010±10Hz 3005±5Hz	High speed connect the TP-7 to GND. push the FWD button twice continuously. High speed first	
2	Head azimuth	AC voltmeter and oscilloscope to LINE output terminal	TCC-153	PB	AC voltmeter	Head azimuth screw	Maximum and same phase at channels L and R	fig-1	
3	Playback level	AC voltmeter to terminals TP5, TP6	MTT-150	PB	AC voltmeter	T1 R115(Ch.L) T1 R116(Ch.R) T2 R133(Ch.L) T2 R134(Ch.R)	300mV		
4	OSC Block	AC voltmeter to P303(T1) and P402(T2) E head read loose coupling	T1, T2 METAL TAPE XS-C60	T1, T2 REC	AC voltmeter	T1 L301 T2 L401	85kHz ±2kHz		
5	HX-PRO	AC voltmeter to TP1,TP2(T1) TP3,TP4(T2)	T1, T2 METAL TAPE XS-C60	T1, T2 REC	AC voltmeter	DECK-A L303.L304 DECK-B L403.L404	Maximum	R371.R372 R469.R470 Maximum	
6	Bias current	fig-2	1kHz -20dB and 12kHz, -20dB	XL-II C-90	REC/PB	AC voltmeter	T1 R371(Ch.L) T1 R372(Ch.R) T2 R469(Ch.L) T2 R470(Ch.R)	Same level at REC/PB	Input VR maximum.
7	Record level	fig-2	1kHz	XL-II C-90	REC	AC voltmeter	Attenuator or AF OSC output	350mV	
					REC/PB	AC voltmeter	T1 R327(Ch.L) T1 R328(Ch.R) T2 R405(Ch.L) T2 R406(Ch.R)	Same level at REC/PB	

Blank tape
 NORAML UD-1 C-90 PLAY torque 30 ~ 70g/cm
 HIGH XL-II C-90 FF. REW torque 90 ~ 180g/cm
 METAL XS C-60 Back tention 2 ~ 5g/cm

ADJUSTMENT POINT

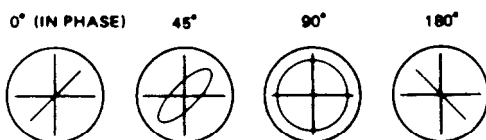
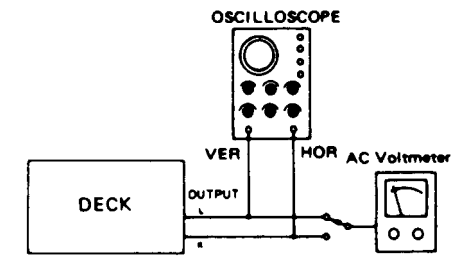
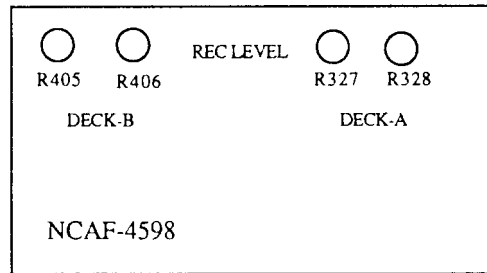
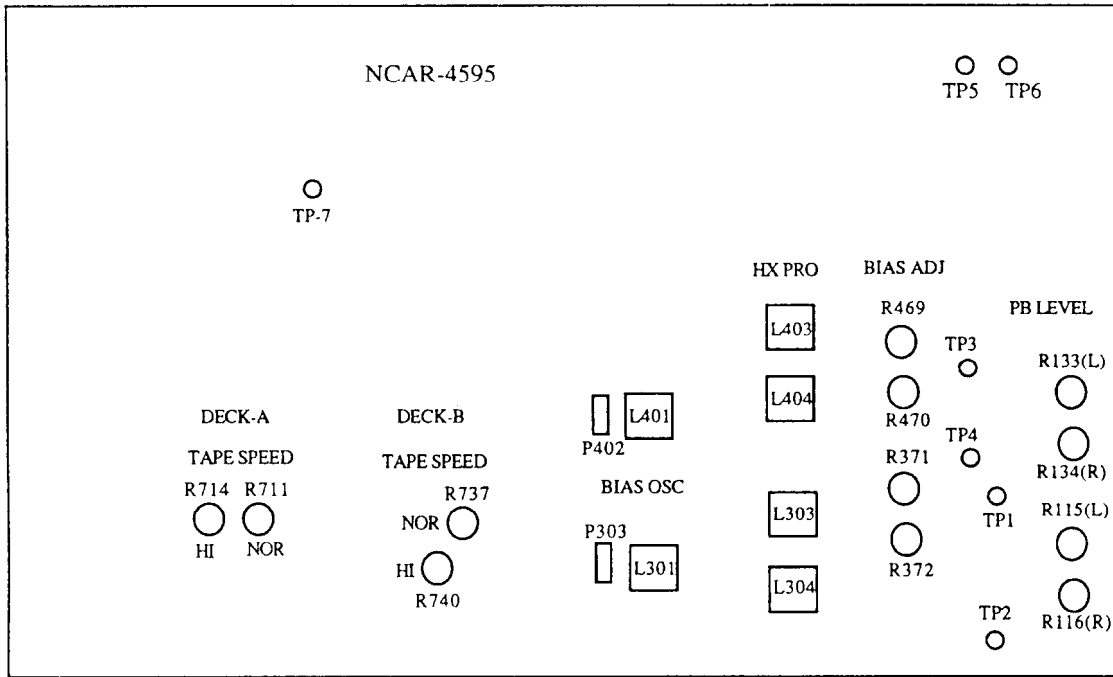

Confirming phase relationship

fig-1

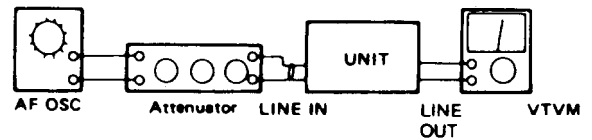
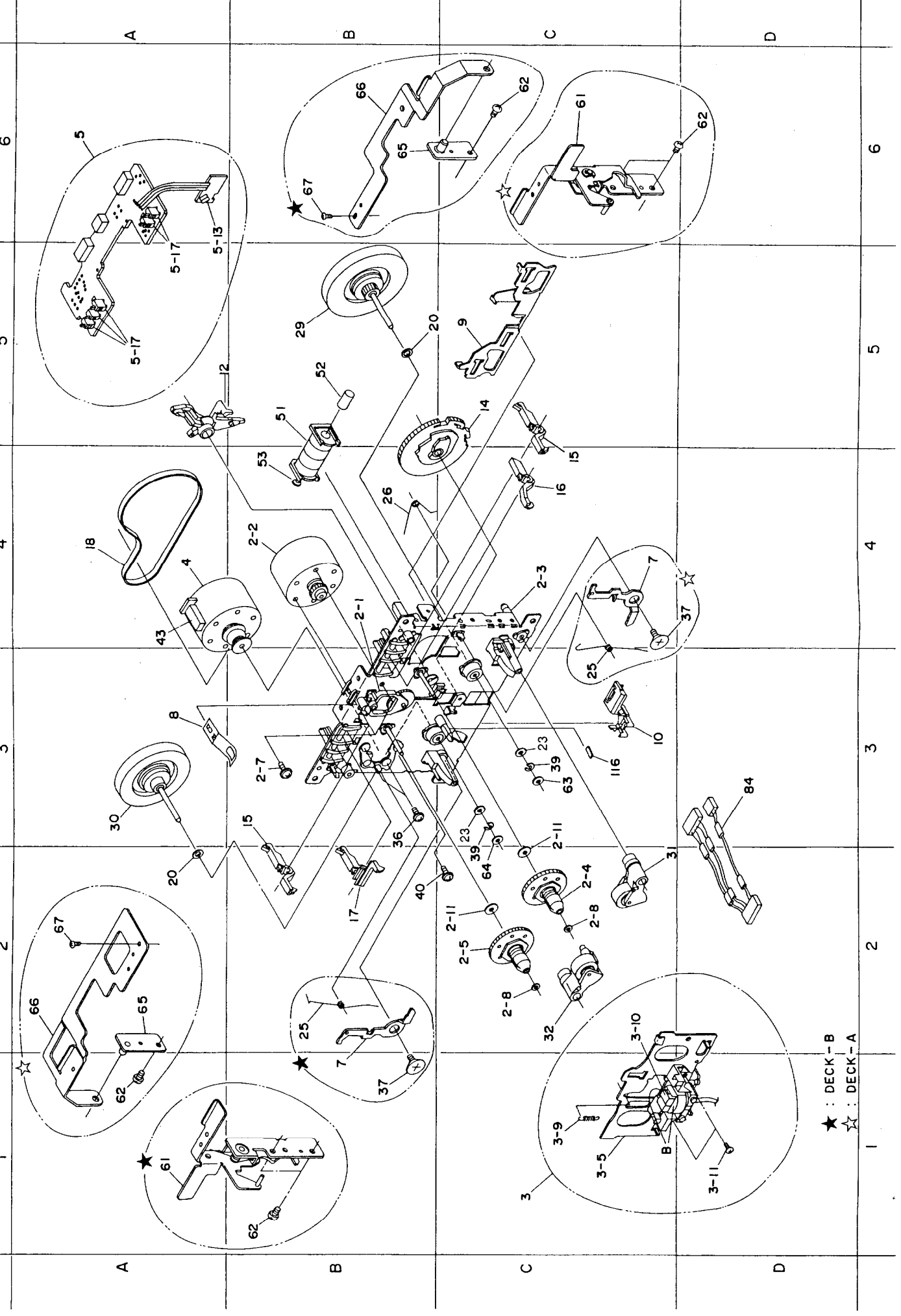

fig-2

TAPE MECHANISM-EXPLODED VIEW



★ : DECK - B
☆ : DECK - A

CHASSIS-EXPLODED VIEW

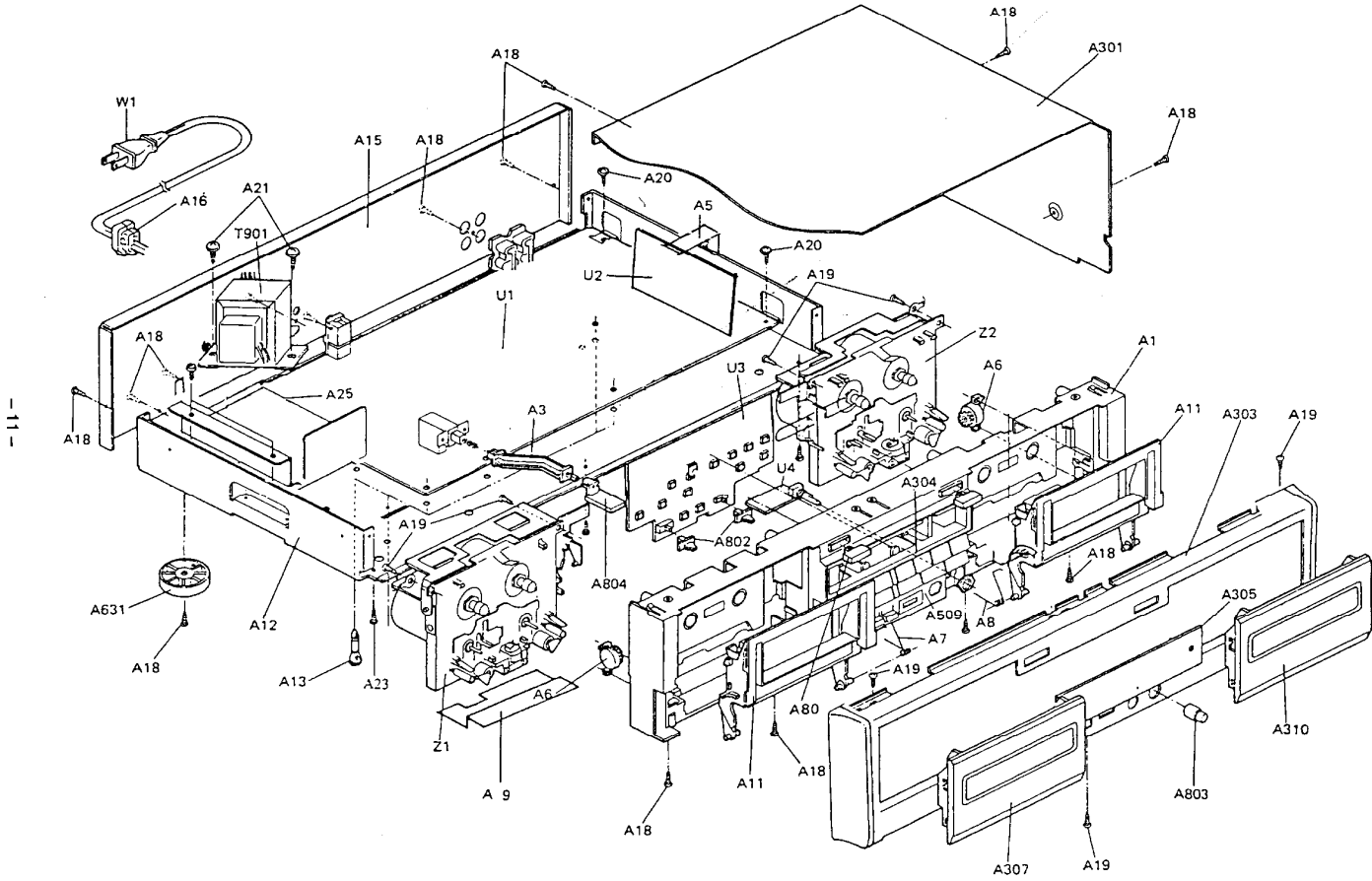

CHASSIS-EXPLODED VIEW PART LIST

REF. NO.	PART NO.	DESCRIPTION	REF. NO.	PART NO.	DESCRIPTION
A1	27110757AY	FRONT BRACKET AS [B]	A801	28324232Y	KNOB (EJ) [B]
	27110758AY	FRONT BRACKET AS [S]		28324720Y	KNOB (EJ) [S]
A3	27273135B	JOINT (POW)	A802	28324799Y	KNOB (DOL) [B]
A5	27141571Y	BRACKET (P)		28324800Y	KNOB (DOL) [S]
A6	28400282	DAMPER	A803	28324338	KNOB (VOL) [B]
A7	27180476A	SPRING (B)		28324722	KNOB (VOL) [S]
A8	27180477A	SPRING (A)	A804	28324234Y	KNOB (POW) [B]
A9	27130646DY	BRACKET (F)		28324721Y	KNOB (POW) [S]
A11	28400473-1AY	FRAME AS (CASSETTE)	P701	2041292510A	FLAT CABLE NCFC1-292510
A12	27100233BY	CHASSIS	△ T901	2300887Y	NPT-1167D [D]
A13	27190480	HOLDER		2300888Y	NPT-1167P [P]
A15	27121718Y	REAR PANEL [D]		2300889Y	NPT-1167DG [W]
	27121719Y	REAR PANEL [P]		2300890Y	NPT-1167Q [Q]
	27121721Y	REAR PANEL [W]	△ S902	25065437Y	NSS-22157P [W]
	27121723Y	REAR PANEL [Q]	△ W1	253174Y	AC CORD AS-UC6-#18 [D]
	27121722Y	REAR PANEL [PX]		253175Y	AC CORD AS-CEE [P/W]
A16	27300750	BUSHING (CORD)		253170	AC CORD AS-SAA [Q]
A18	834430088	TAP-TIGHT SCREW 3TTS+8BBC	U1	1N150595-2	NAAR-4595-2
A19	833430080	TAP-TIGHT SCREW 3TTP+8PBC	U2	1N150598-2	NAAF-4598-2
A20	831130088	TAP-TIGHT SCREW 3TTW+8B	U3	1N150597-2	NADIS-4597-2
A21	830440069	TAP-TIGHT SCREW 4x6	U4	1N150549-2	NAETC-4649-2
A25	27130608GY	BRACKET (PT)	U5	1N150550-2	NAETC-4650-2
A301	28184479Y	TOP COVER	Z1	244174	CASSETTE DECK MECHANISM, NDM-165
	28140837Y	CUSHION 250x10x.9t	Z2	244175	CASSETTE DECK MECHANISM, NDM-166
A303	1N150701K	FRONT PANEL [B]			
	1N151701K	FRONT PANEL [S]			
A304	27215243Y	COSMETIC FRAME (F) [B]			
	27215244Y	COSMETIC FRAME (F) [S]			
A305	28191652Y	CLEAR PLATE			
A307	27301658Y	CASSETTE LID AS (A) [B]			
	27301660Y	CASSETTE LID AS (A) [S]			
	27301654Y	WINDOW [B]			
	27301664Y	WINDOW [S]			
A310	27301652-1Y	CASSETTE LID AS (B) [B]			
	27301662Y	CASSETTE LID AS (B) [S]			
A509	27215245Y	COSMETIC FRAME (P) [B]			
	27215246Y	COSMETIC FRAME (P) [S]			
A631	27175254AY	LEG AS			

NOTE [D]: Only 120V model
 [P]: Only 230V model
 [W]: Only World wide model
 [Q]: Only 240V model
 [PX]: Only PX model
 [S]: Only Silver model
 [B]: Only Black model

NOTE: THE COMPONENTS IDENTIFIED BY MARK △ ARE CRITICAL FOR RISK OF FIRE AND ELECTRIC SHOCK. REPLACE ONLY WITH PART NUMBER SPECIFIED.

PRINTED CIRCUIT BOARD-PARTS LIST

CIRCUIT NO.	PARTS NO.	DESCRIPTION		
C503	354781099	0.1 μ F50V, ELECT.	Miscellaneous 27160211-1 RAD-68B, RADIATOR 27160211 RAD-68, RADIATOR 27141059 E PLATE 82143006 3P+6FN(BC), SCREW 25060092 NTM-1S33, TERMINAL	
C504	354784799	0.47 μ F50V, ELECT.		
C601	354780479	4.7 μ F50V, ELECT.		
C602	354780109	1 μ F50V, ELECT.		
C704	354741019	100 μ F16V, ELECT		
C710	354741019	100 μ F16V, ELECT		
C716	354780229	2.2 μ F50V, ELECT.		
CIRCUIT NO.	PARTS NO.	DESCRIPTION		
C720, C721	354780109	1 μ F50V, ELECT.		
C723	354761009	10 μ F35V, ELECT.		
C901	3500065A	0.01 μ F AC400V, IS.		
C904	354744719	470 μ F16V, ELECT.		
C906	3504168	1300 μ F25V, ELECT.		
C908	354742219	220 μ F16V, ELECT.		
C910, C911	354741019	100 μ F16V, ELECT		
C913	354741019	100 μ F16V, ELECT		
C915	354761019	100 μ F35V, ELECT.		
C916, C917	354780479	4.7 μ F50V, ELECT.		
C918	354762209	22 μ F35V, ELECT.		
C919	354741009	10 μ F16V, ELECT.		
C922	354742219	220 μ F16V, ELECT.		
C923	354741019	100 μ F16V, ELECT		
C924	354741009	10 μ F16V, ELECT.		
C925, C926	354744709	47 μ F16V, ELECT.		
C927	393141027S	1000 μ F16V, FM		
C928	354761009	10 μ F35V, ELECT.		
	Resistors			
R115, R116	5210218	N06HR20KBD		
R133, R134	5210218	N06HR20KBD		
R371, R372	5210217	N06HR10KBD		
R469, R470	5210217	N06HR10KBD		
R704	442524704F	RS1/2WBJ 47 Ω		
R711	5210218	N06HR20KBD		
R714	5210217	N06HR10KBD		
R730	442524704F	RS1/2WBJ 47 Ω		
R737	5210218	N06HR20KBD		
R740	5210217	N06HR10KBD		
R762, R763	49163104415	RM1/10I100K \times 15		
R763	49163104405	RM1/10I100K \times 5		
R901	441723904F	RS2WBJ39 Ω		
R903, R904	452530224F	RNU1/2WCJ2.2 Ω		
R907	442524714F	RS1/2WBJ 470 Ω		
	Switch			
S901	25035636	NPS-111-L590P		
	Plug, Socket			
P101, P102	25055136	NPLG-6P120		
P201	25045338	NPJ-4PDBL189		
P301	25055105	NPLG-8P89		
P303	25055132	NPLG-2P116		
P401	25055106	NPLG-9P90		
P402	25055132	NPLG-2P116		
P701A	25050861	NSCT-29P656		
P702A	2000991	NSAS-14P943		
P703A	2002391210	NSAS-12P0235		
P704A	2000992	NSAS-6P0944		
P705A	2000991	NSAS-14P943		
P706A	2002391210	NSAS-12P0235		
P707A	2000992	NSAS-6P0944		
P708	25045330	NPJ-2PDBL184		
P951, P952	25055133	NPLG-3P117		

SCHEMATIC DIAGRAM (1/2)

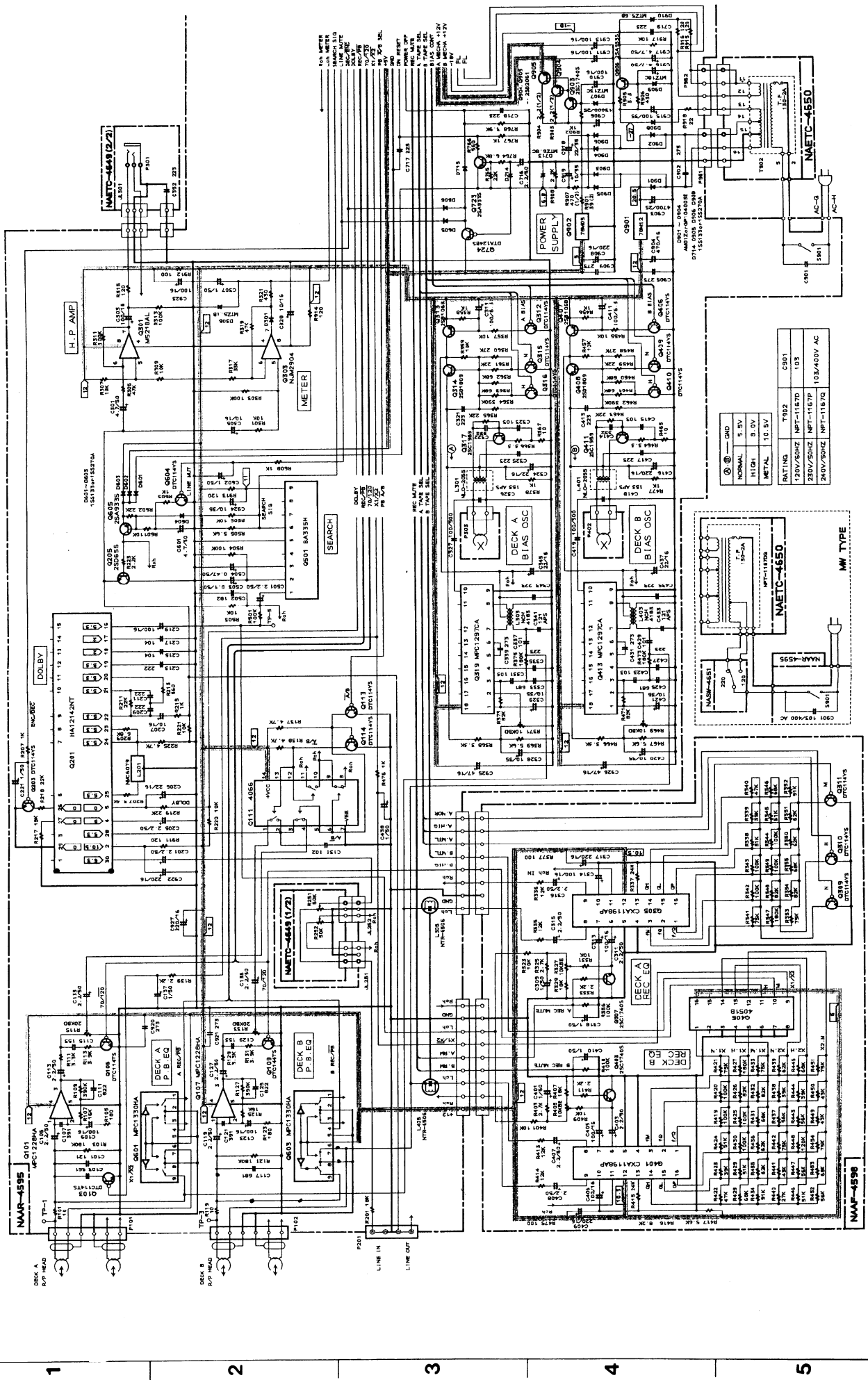

①	②	③	④
⑤	⑥	⑦	⑧
⑨	⑩	⑪	⑫
⑬	⑭	⑮	⑯
⑰	⑱	⑲	⑳
㉑	㉒	㉓	㉔
㉕	㉖	㉗	㉘
㉙	㉚	㉛	㉜
㉝	㉞	㉟	㊱
㊲	㊳	㊴	㊵
㊶	㊷	㊸	㊹
㊺	㊻	㊼	㊽
㊾	㊿		

RAITING	T902	C901
120V/50HZ	NPT-1157D	103
230V/50HZ	NPT-1157P	103A40V AC
240V/50HZ	NPT-1157Q	

NAAR-4596

MW TYPE

NAETC-4650

NAETC-4649 (2/2)

A B C D E F G

SCHEMATIC DIAGRAM (2/2)

NAAR-4595

- NOTE**
- THE COMPONENTS IDENTIFIED BY MARK Δ ARE CRITICAL FOR SAFETY.
 - REPLACE ONLY WITH PART NUMBER SPECIFIED.
 - ALL PNP TRANSISTORS ARE EQUIVALENT TO 2N4101A-OR UNLESS OTHERWISE NOTED.
 - ALL DIODES ARE EQUIVALENT TO 2SC1915-OR UNLESS OTHERWISE NOTED.
 - ALL CAPACITORS ARE 10% TOLERANCE UNLESS OTHERWISE NOTED.
 - ALL RESISTORS ARE IN OHMS Ω UNLESS OTHERWISE NOTED.
 - ALL RESISTORS IN BOARD ARE THE PRINTING SIZE OF THE PARTS EXCEPT PRINTING SIZE OF BOARD.
 - CIRCUIT IS SUBJECT TO CHANGE FOR IMPROVEMENT.

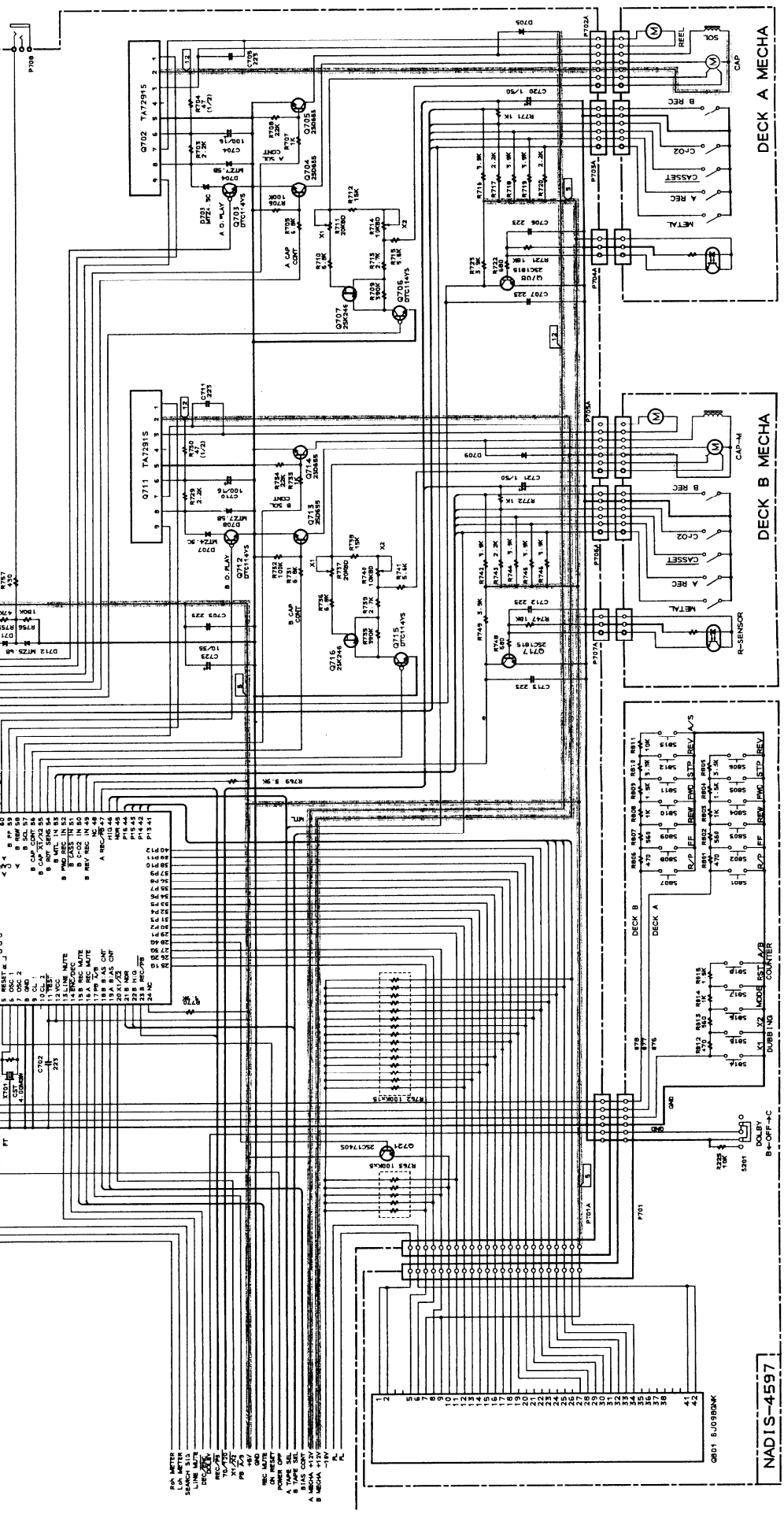

NAD IS-4597

FLUORESCENT TUBU (BJ-098GNK)

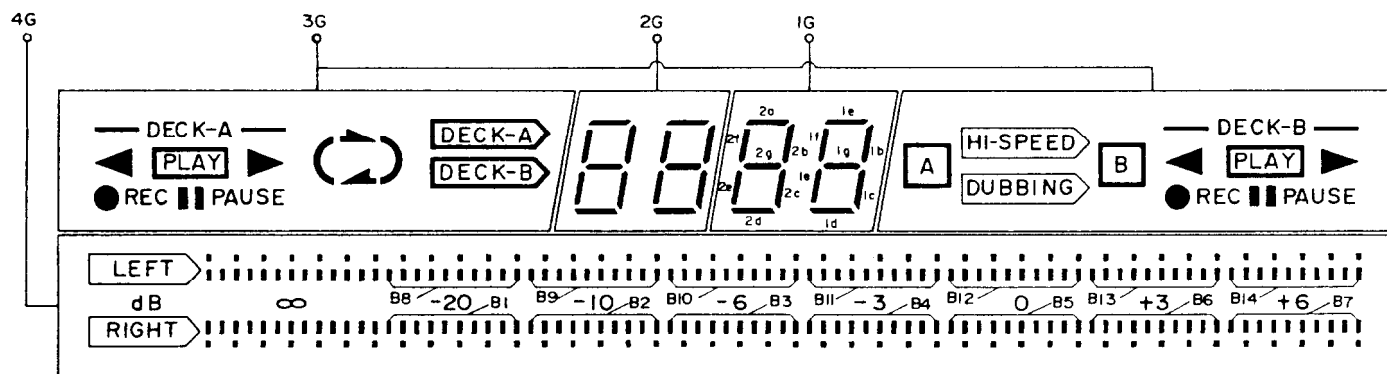

PIN CONNECTION

PIN NO.	1	2	3	4	5	6	7	8	9	10	11	12	13	14	15	16	17	18	19	20	21	22	23	24	25	26	27	28	29	30	31	32	33	34	35	36	37	38	39	40	41	42	
CONNECTION	F	F	N	N	N	N	N	N	N	P	P	P	P	P	P	P	N	N	N	N	N	P	P	P	P	P	P	P	P	P	P	P	P	G	G	G	G	G	G	P	P	F	F

NOTE 1) F1, F2 --- Filament
 2) NP ----- No pin
 3) NC ----- No connection

ANODE CONNECTION

	4G	3G	2G	1G
P1	B 1	▶ PLAY (DECK-A)	1 a	1 a
P2	B 2	● REC (DECK-A)	1 b	1 b
P3	B 3	▬ PAUSE (DECK-A)	1 c	1 c
P4	B 4	-	1 d	1 d
P5	B 5	◀ (DECK-A)	1 e	1 e
P6	B 6	▶ (DECK-A)	1 f	1 f
P7	B 7	▶ HI-SPEED	1 g	1 g
P8	-	A DUBBING B	-	-
P9	B 8	▶ PLAY (DECK-B)	2 a	2 a
P10	B 9	● REC (DECK-B)	2 b	2 b

	4G	3G	2G	1G
P11	B 10	▬ PAUSE (DECK-B)	2 c	2 c
P12	B 11	()	2 d	2 d
P13	B 12	◀ (DECK-B)	2 e	2 e
P14	B 13	▶ (DECK-B)	2 f	2 f
P15	B 14	▶ DECK-A	2 g	2 g
P16	-	▶ DECK-B	-	-
P17	-	◀ DECK-A ◀ DECK-B	-	-
P18	SC	-	-	-

ONKYO CORPORATION

International Division: 2-1 Nisshin-cho, Neyagawashi, OSAKA, 572, JAPAN

Tel: 0720-31-8133 Fax: 0720-34-1340

ONKYO U.S.A. CORPORATION

200 Williams Drive, Ramsey, N.J. 07446, U.S.A. Tel: 201-825-7950 Fax: 201-825-8150

ONKYO EUROPE

Immeuble Le DIAMANT, Domaine Technologique De Saclay, 4 rue Rene Razel, 91892 SACLAY,

FRANCE Tel: (1)69 33 14 15 FAX: (1)69 41 29 66

ONKYO FRANCE

Immeuble Le DIAMANT, Domaine Technologique De Saclay, 4 rue Rene Razel, 91892 SACLAY,

FRANCE Tel: (1)69 33 14 00 FAX: (1)69 41 35 84

PACKING VIEW

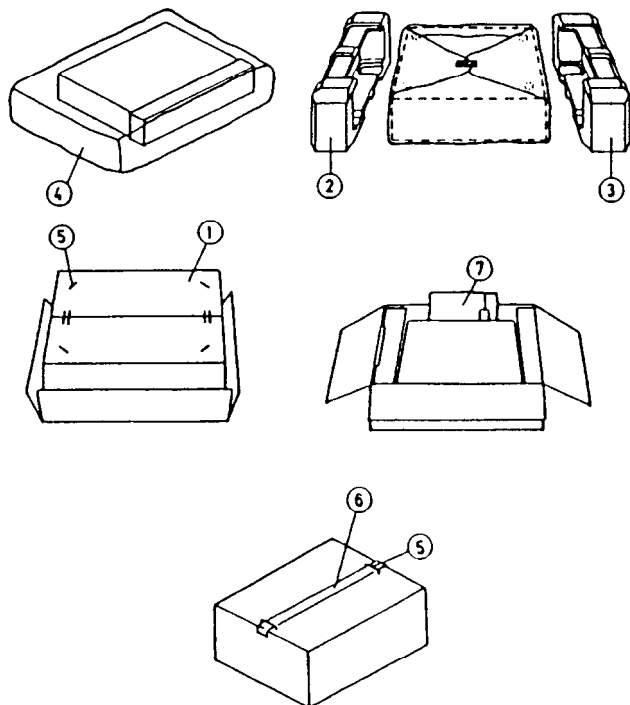

PART LIST

REF. NO.	PART NO.	DESCRIPTION
1	29052579Y	Carton box [B]
	29052581Y	Carton box [S]
	29052583Y	Carton box [X]
	29091452CY	Pad (L)
	29091453CY	Pad (R)
	29100034AY	620×850 Poly bag
	282301	Sealing hook
6	29110071	Dampion tape
	29091633Y	Pad (CA)
	29095704Y	130×130 Sheet
	Accessory bag ass'y	
7	29341807Y	Instruction manual [D]
	29341809Y	Instruction manual [P/W]
	29100097AY	350×250 Poly bag
	2010244Y	Connection cable
	29358002J	S.S.list
	29365019A	Warranty card [N]
	29365024A	Warranty card [F]
	29365021	Warranty card [X]
	29100107	Poly bag [F]
	25055040	CV-K-2, Conversion plug [W]
	25055251	CV-CP, Conversion plug [X]

NOTE [D]: Only 120V model
 [N]: Only U.S.A. model
 [P]: Only 230V model
 [W]: Only worldwide model
 [F]: Only France model
 [B]: Black model
 [S]: Silver model
 [X]: PX model

4066 (ANALOG SW)

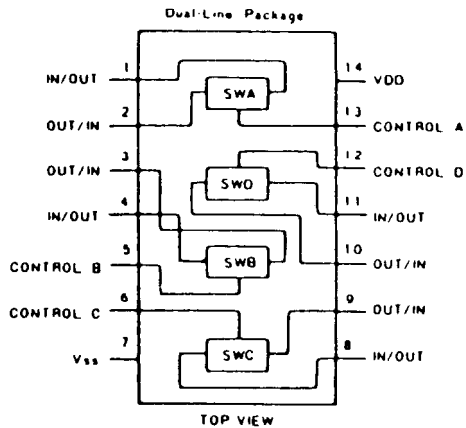

CXA1198A (REC EQ)

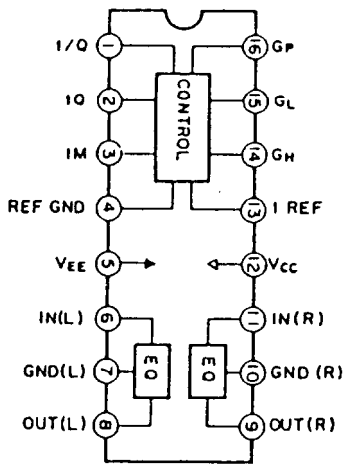

TA7291S (MOTOR DRIVE)

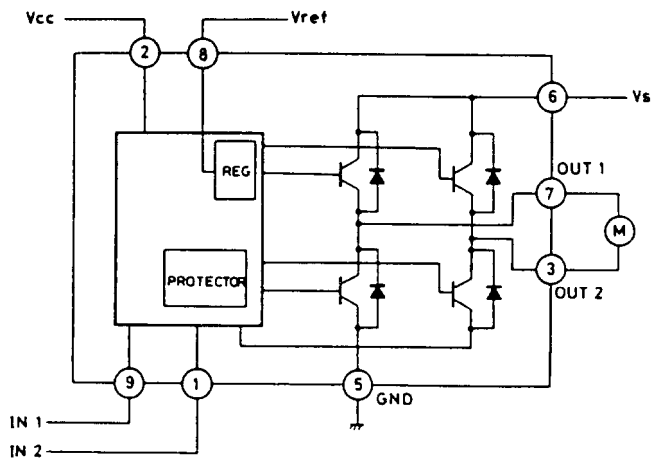

INPUT		OUTPUT		MODE
IN 1	IN 2	OUT 1	OUT 2	
0	0	∞	∞	STOP
1	0	H	L	CW/CCW
0	1	L	H	CCW/CW
1	1	L	L	BRAKE