

# ONKYO SERVICE MANUAL

## STEREO CASSETTE TAPE DECK MODEL TA-RW44

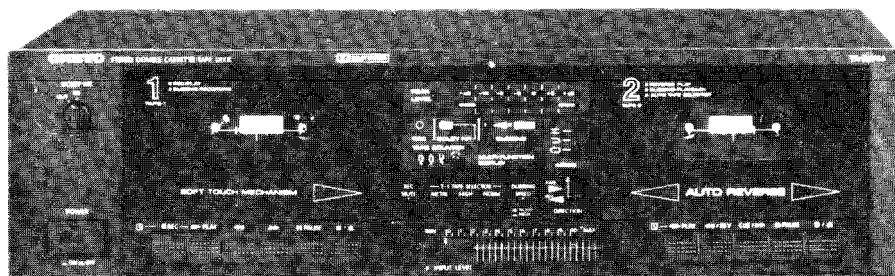

### Black model

UDN, UDC, UD

120V AC, 60Hz

### SAFETY-RELATED COMPONENT WARNING!!

COMPONENTS IDENTIFIED BY MARK  $\Delta$  ON THE SCHEMATIC DIAGRAM AND IN THE PARTS LIST ARE CRITICAL FOR RISK OF FIRE AND ELECTRIC SHOCK. REPLACE THESE COMPONENTS WITH ONKYO PARTS WHOSE PART NUMBERS APPEAR AS SHOWN IN THIS MANUAL.

MAKE LEAKAGE-CURRENT OR RESISTANCE MEASUREMENTS TO DETERMINE THAT EXPOSED PARTS ARE ACCEPTABLY INSULATED FROM THE SUPPLY CIRCUIT BEFORE RETURNING THE APPLIANCE TO THE CUSTOMER.

## SPECIFICATIONS

Track System:	4-tracks, 2-channels
Recording System:	AC bias
Erasing System:	AC erase
Tape Speed:	4.8 cm/sec (1-7/8 i.p.s.)
Wow and Flutter:	0.07% (WRMS)
Frequency Response:	20 - 15,000 Hz (Normal) (30 - 14,000 Hz $\pm$ 3dB) 20 - 16,000 Hz (High) (30 - 15,000 Hz $\pm$ 3dB) 20 - 17,000 Hz (Metal) (30 - 16,000 Hz $\pm$ 3dB)
S/N Ratio:	Dolby NR out: 56 dB (metal position tape) A noise reduction of 10 dB above 5 kHz and 5 dB at 1 kHz is possible with Dolby NR.
Input Jacks:	Line IN: 2 Input sensitivity: 60 mV Input impedance: 50 kohms
Outputs:	Line OUT: 2 Standard output level: 500mV (0 dB) Optimum load impedance: over 50 kohms
Motors:	DC servo motor: 2
Heads:	REC/PB: Special Hard Permalloy $\times$ 2 Erase head: Ferrite $\times$ 1
Power Supply:	AC 120V/60Hz
Power Consumption:	15 watts
Dimensions:	435(W) $\times$ 122(H) $\times$ 259(D) mm (17-1/8" $\times$ 4-7/8" $\times$ 10-3/16")
Weight:	4.4 kg. (9.7 lbs.)

Specifications and external appearance are subject to change without notice because of product improvements.

# ONKYO

## AUDIO COMPONENTS

# SCHEMATIC DIAGRAM

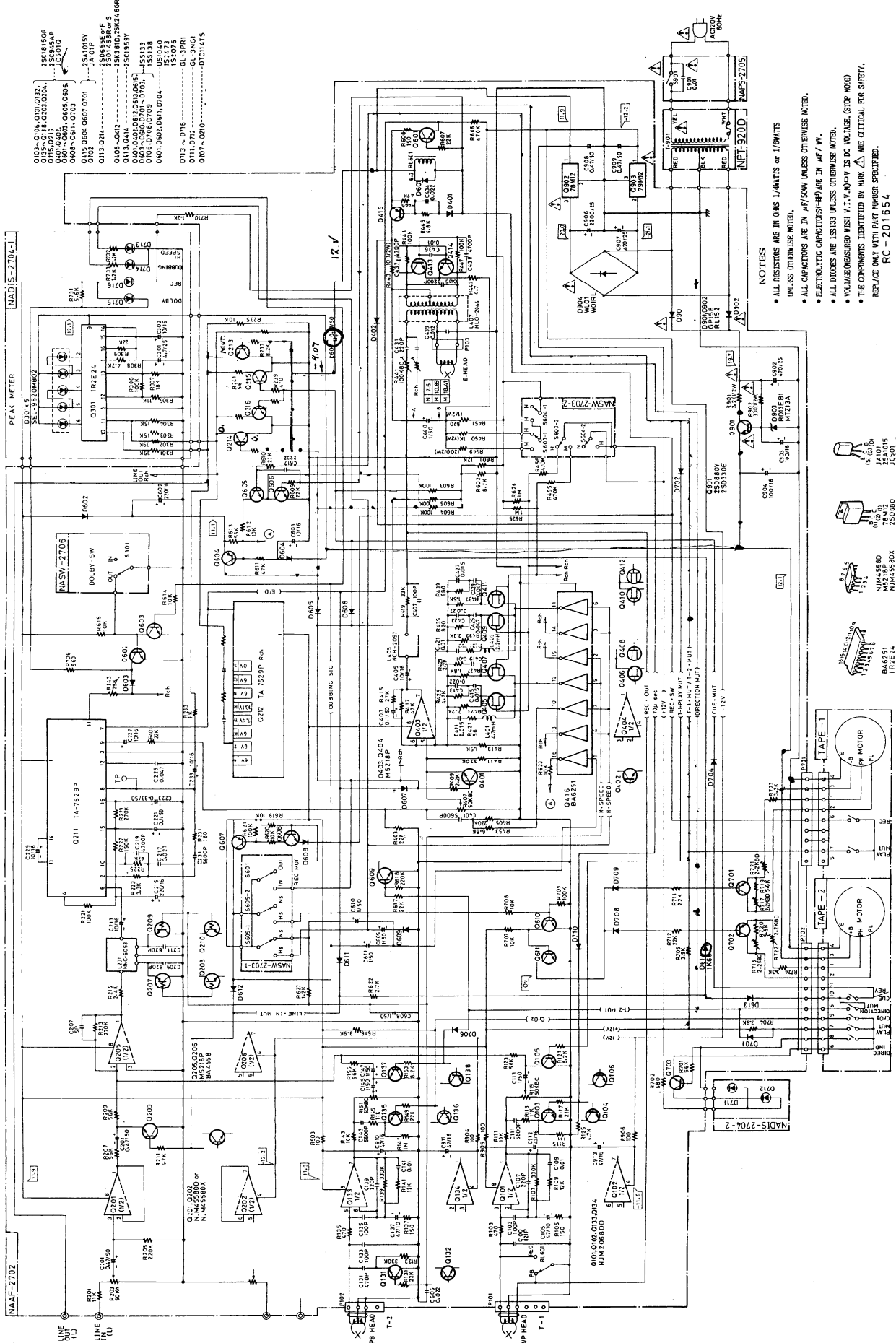

- O03-O16 O11-O12
- O15-O18 O20-O22
- O19-O21
- O23-O25
- O26-O28
- O29-O31
- O32-O34
- O35-O37
- O38-O40
- O41-O43
- O44-O46
- O47-O49
- O50-O52
- O53-O55
- O56-O58
- O59-O61
- O62-O64
- O65-O67
- O68-O70
- O71-O73
- O74-O76
- O77-O79
- O80-O82
- O83-O85
- O86-O88
- O89-O91
- O92-O94
- O95-O97
- O98-O100

- NOTES
- ALL RESISTORS ARE IN OHMS / KWTS or / MWTS UNLESS OTHERWISE NOTED.
  - ALL CAPACITORS ARE IN  $\mu$ F/5MV UNLESS OTHERWISE NOTED.
  - ELECTROLYTIC CAPACITORS (HEP) ARE IN  $\mu$ F / W.
  - ALL DIODES ARE 1N513 UNLESS OTHERWISE NOTED.
  - VOLTAGE MEASURED WITH 1 V.T.H. (V) IS DC VOLTAGE (STOP MODE)
  - THE COMPONENTS IDENTIFIED BY MARK  $\Delta$  ARE CRITICAL FOR SAFETY. REPLACE ONLY WITH PART NUMBER SPECIFIED.

- 250R15GP
- 250R16GP
- 250R17GP
- 250R18GP
- 250R19GP
- 250R20GP
- 250R21GP
- 250R22GP
- 250R23GP
- 250R24GP
- 250R25GP
- 250R26GP
- 250R27GP
- 250R28GP
- 250R29GP
- 250R30GP
- 250R31GP
- 250R32GP
- 250R33GP
- 250R34GP
- 250R35GP
- 250R36GP
- 250R37GP
- 250R38GP
- 250R39GP
- 250R40GP
- 250R41GP
- 250R42GP
- 250R43GP
- 250R44GP
- 250R45GP
- 250R46GP
- 250R47GP
- 250R48GP
- 250R49GP
- 250R50GP
- 250R51GP
- 250R52GP
- 250R53GP
- 250R54GP
- 250R55GP
- 250R56GP
- 250R57GP
- 250R58GP
- 250R59GP
- 250R60GP
- 250R61GP
- 250R62GP
- 250R63GP
- 250R64GP
- 250R65GP
- 250R66GP
- 250R67GP
- 250R68GP
- 250R69GP
- 250R70GP
- 250R71GP
- 250R72GP
- 250R73GP
- 250R74GP
- 250R75GP
- 250R76GP
- 250R77GP
- 250R78GP
- 250R79GP
- 250R80GP
- 250R81GP
- 250R82GP
- 250R83GP
- 250R84GP
- 250R85GP
- 250R86GP
- 250R87GP
- 250R88GP
- 250R89GP
- 250R90GP
- 250R91GP
- 250R92GP
- 250R93GP
- 250R94GP
- 250R95GP
- 250R96GP
- 250R97GP
- 250R98GP
- 250R99GP
- 250R100GP

ONKYO CORPORATION

TAPE MECHANISM-EXPLODED VIEW (TAPE-1)

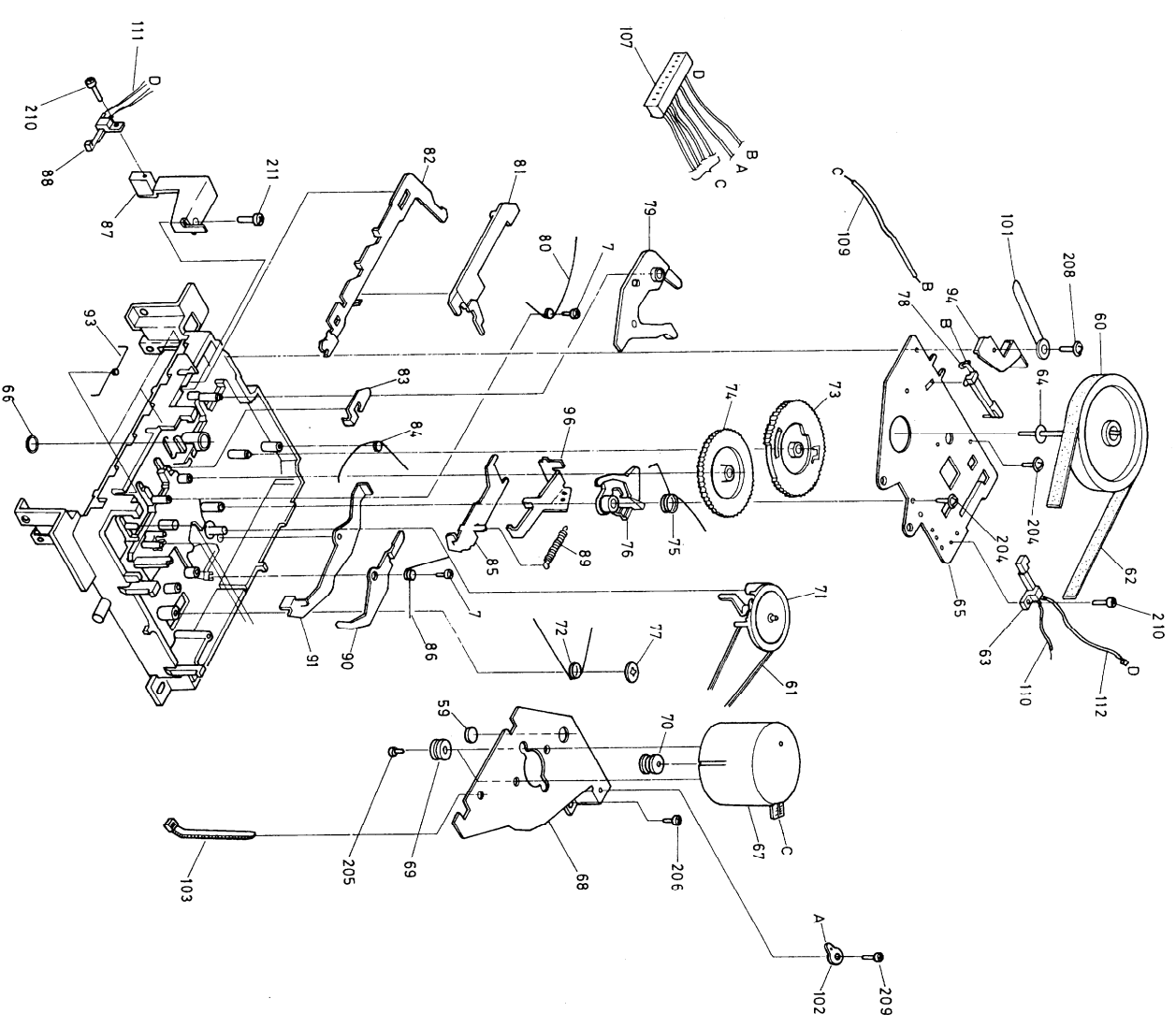
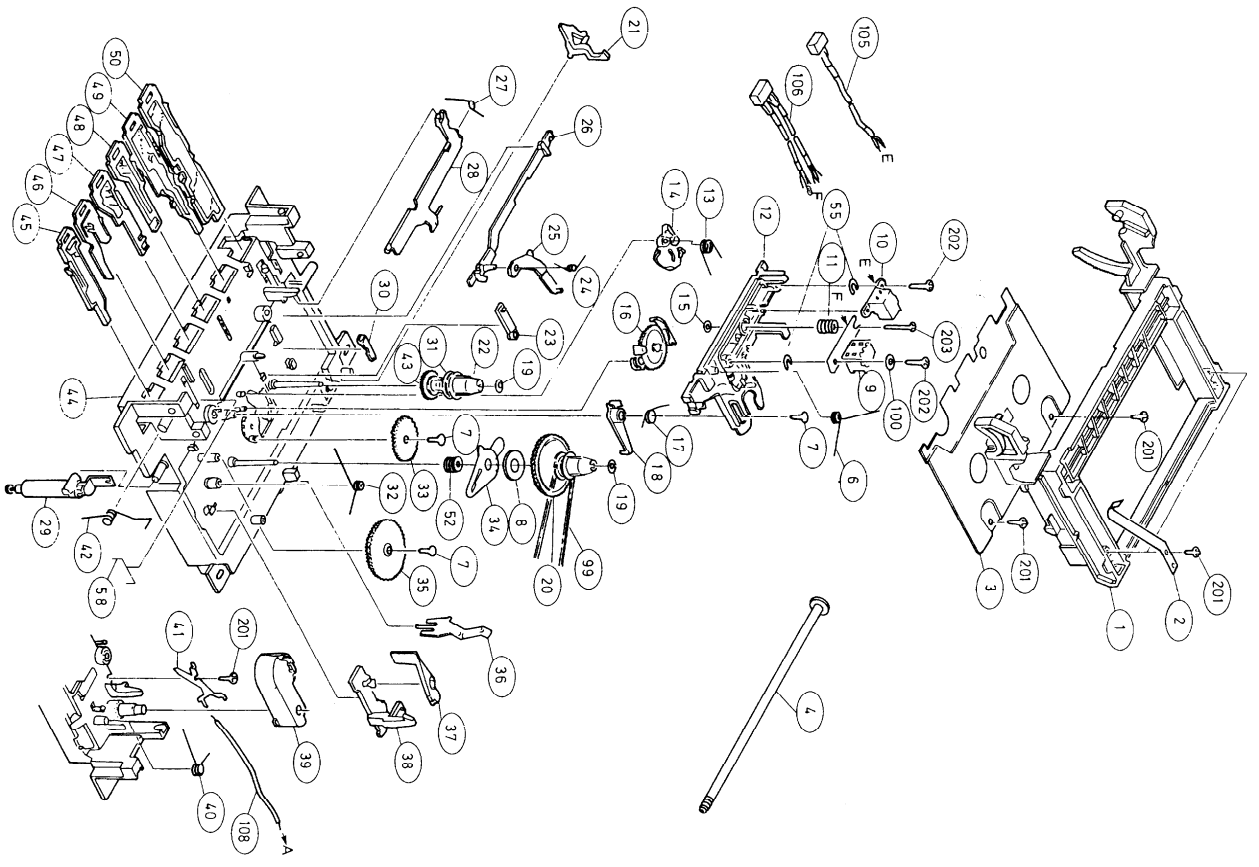

1 2 3 4 5 6 7

TAPE MECHANISM-EXPLODED VIEW (TAPE-2)

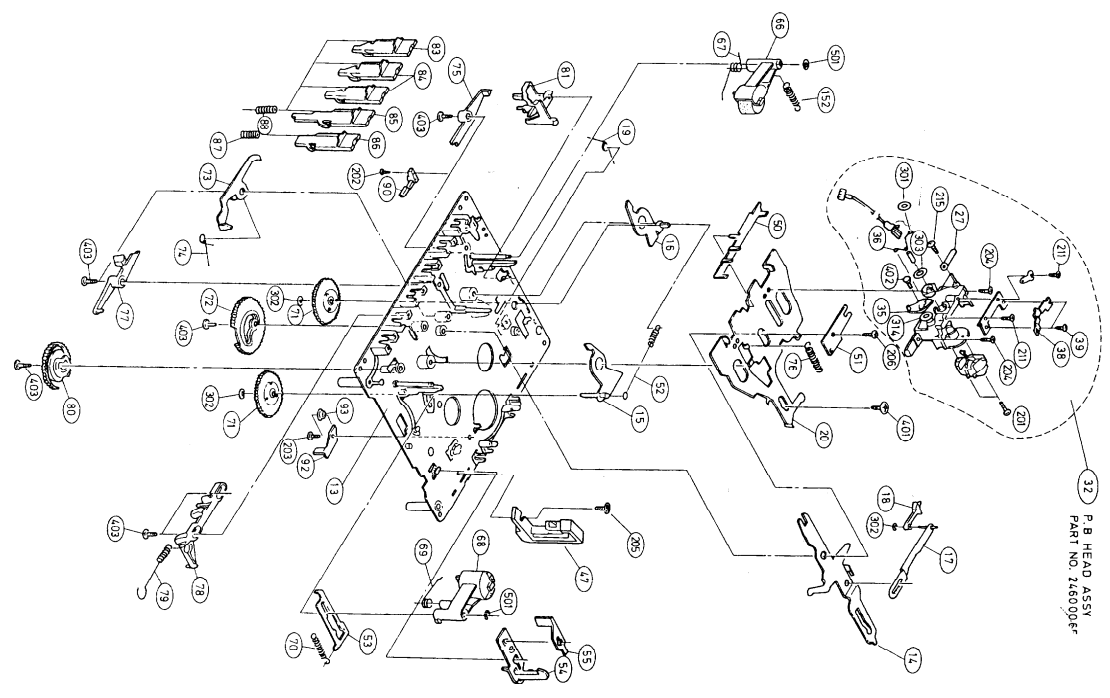
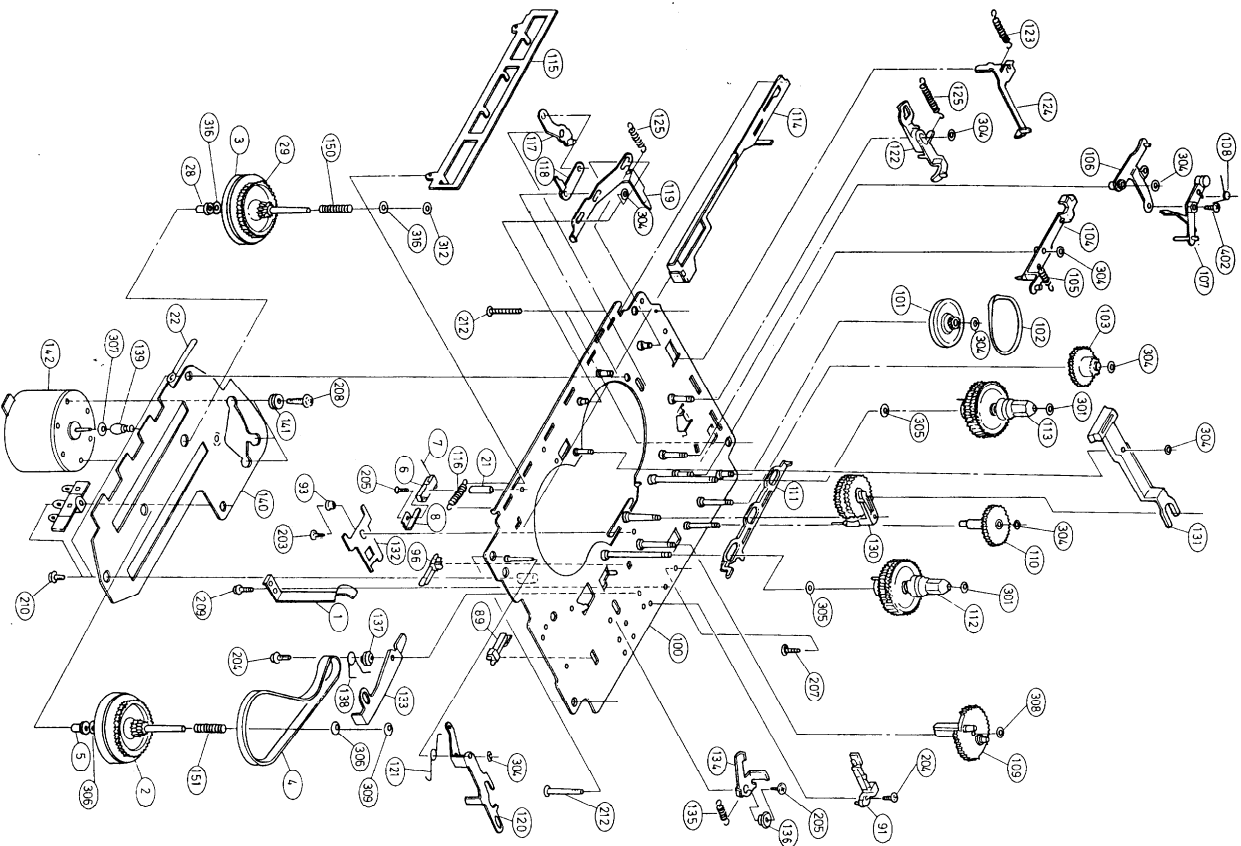

32 P.B. HEAD ASSY  
PART NO. 2460006F

ONKYO CORPORATION

International Division: No. 24 Mori Bldg., 23-5, 3-chome, Nsh-Sinbashi, Minato-ku, Tokyo, Japan  
Telex: 2423551 ONKYO J Tel. 03-432-6981

ONKYO U.S.A. CORPORATION  
200 Williams Drive, Ramsey, N.J. 07446 Telex: 25-710988-1033 Tel. 201-825-7950

# SERVICE PROCEDURES

## 1. Replacement of power supply cord

There are two power supply cord outlets on the strainrelief. Insert them in prescribed direction to ensure safety. AS-UC-3 (UD<120V> model) should be inserted lengthwise and other types of cords should be inserted horizontally.

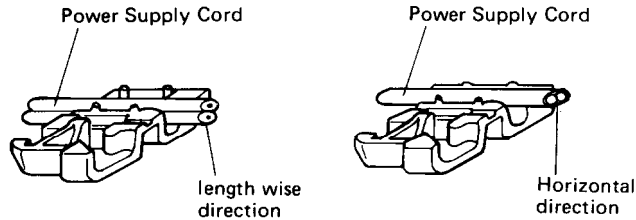

## 2. Instruction resistance measurement

Connect the insulating-resistance tester between the plug of power supply cord and chassis.

Specifications; 500V more than 10MΩ

## IR-2E24 (LEVEL METER)

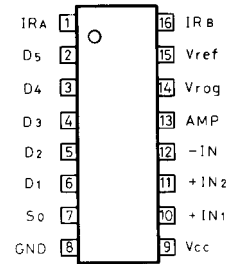
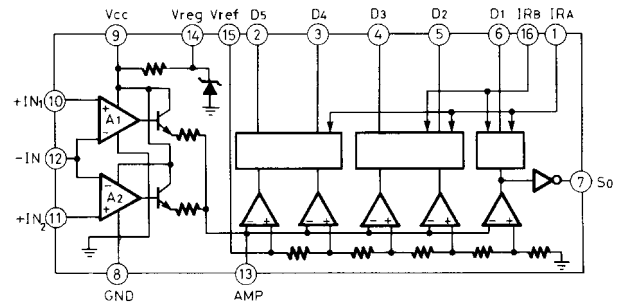

TOP VIEW

# IC BLOCK DIAGRAM

## BA6251 (REC AMP. EQ. SW)

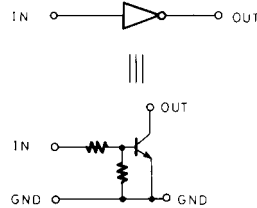
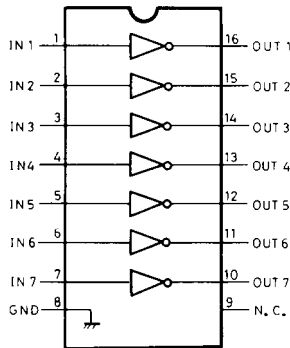

## NJM-2068D-D

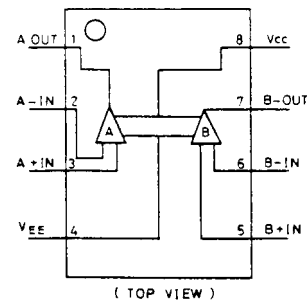

( TOP VIEW )

## TA7629P (Dolby)

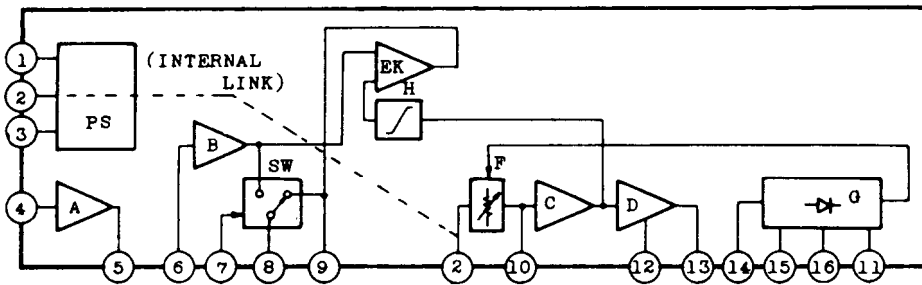

- 4. Input
- 7. Encode/Decode switch
- 8. Decode output
- 9. Encode output



# TAPE MECHANISM OPERATION (TAPE-1)

## 1. FF and REW Auto-Stop Mechanism

When the S or T reel is stopped during REW or FF, the drive gear, which is still trying to rotate, moves upward for REW and downward for FF.

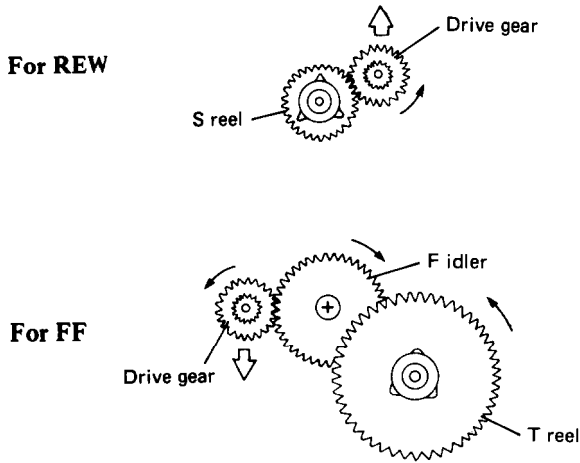

When the FR idler (drive gear) moves up and down 1, the FR unlock lever also moves up and down 2 causing the FR lock plate to rotate (move upward) 3. As the FR lock plate moves upward (flot S), the lever locking hook is released to switch to the stop mode.

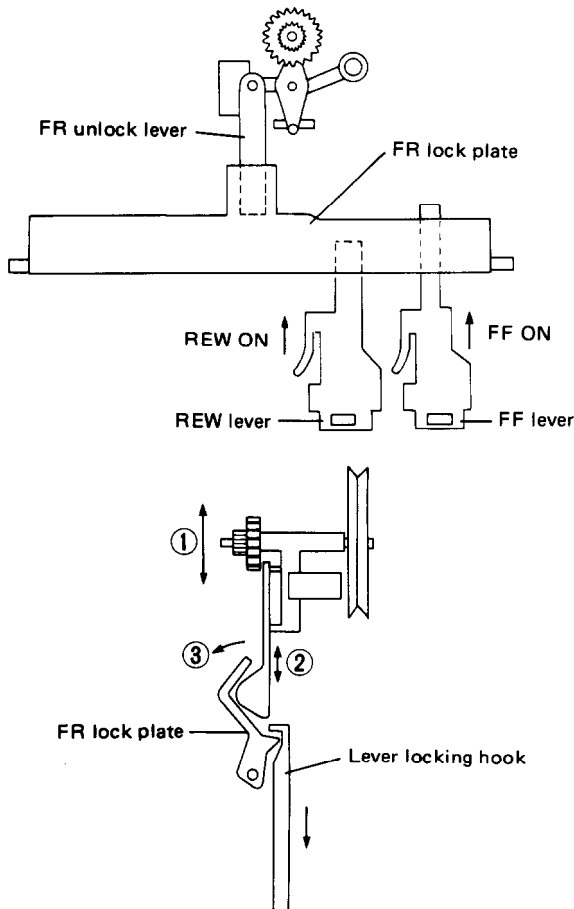

## 2. PLAY Auto-Stop Mechanism

### 2-1 Tape Transport During the play Mode

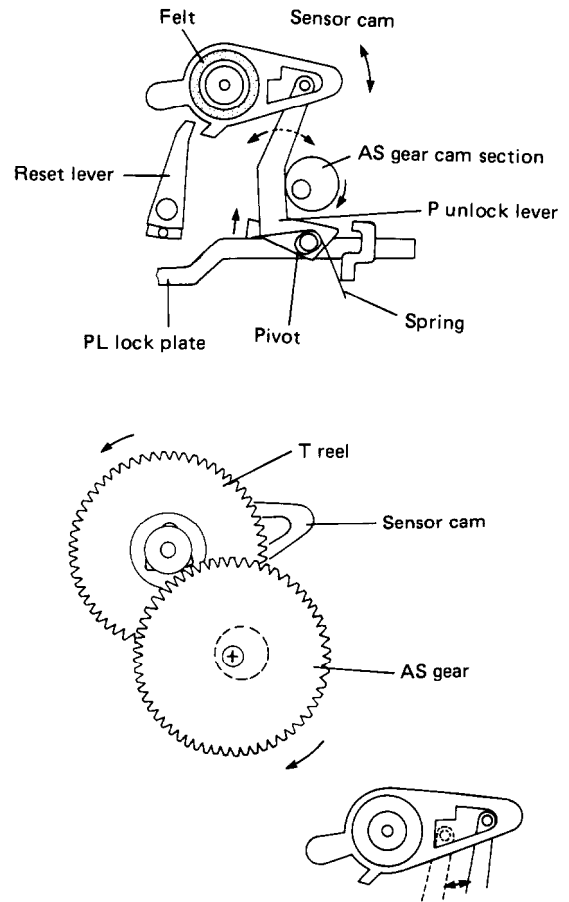

When the T reel rotates, friction with the felt causes the sensor cam to rotate to the left. However, the rotations of the AS gear (from the cam) cause the P unlock lever to back and forth. The sensor arm also moves back forth because the boss of the P unlock lever is in the sensor cam. The boss therefore moves back and forth a long the underside of the inside of the sensor cam.

### 2-2 Auto-Stop

If the T reel is stopped during play mode transport, the force generated by the sensor arm rotating to the left no longer exists, but the AS gear does not stop rotating. As a result, the P unlock lever boss, which was moving back and forth on the underside of the inside of the sensor cam, now moves to the top of the cam. However, since the top is shorter, the back and forth movement of the P unlock lever is stopped it can be completed. This causes the lever to pivot at the point where it has stopped, so the PL lock plate is moved to the left and PLAY lever is unlocked.

## TAPE MECHANISM OPERATION (TAPE-2)

**PLAY operation** (refer to Fig. 1 and Mechanism Dis-assembly dwg.)

Push play button (83) → Trigger (ASSIST) (77) lock shifts → Cam (ASSIST) (72) meshes with Flywheel AS(C) (2) → Cam (ASSIST) (72) turns, Base AS (HEAD) (20) raises. For FWD, by means of arm (REVERSE) (14), Flywheel AS(C) (2), Gear A (71) (right side) and Reel AS (F) (112) mesh, and tape reels.

### F.F. operation

If FF button (84) is pushed, by means of Arm (FR) (131), Arm (DRIVE) (130) gear, Flywheel AS (C) (2), and Reel AS (F) (112) mesh, and tape reels.

### REW operation

If REW button (84) is pushed, by means of Arm (FR) (131), Arm (DRIVE) (130) gear, Flywheel (3), and Reel AS (R) (113) mesh, and tape reels.

**AUTO STOP operation** (refer to Mechanism Exploded View for No. following part name)

At the end of the tape, the reel stops.

Actuating plate (CLUTCH) (111) → Sensor (107) operates, Sensor (107) is pulled by the Arm (SENSOR) (106) at Gear (STOP) (110) → Arm (RELEASE) (122) → Lever AS (RELEASE) (117) → Release (18) operates, Release plate (115) releases.

### Head reverse rotation

With the Change arm (MODE) (81) at the Reverse mode position, when the tape end is reached, and when the mechanism enters the auto stop operation, Trigger (104) operates, Cam AS (109) lock opens, Cam AS (109) makes a half turn, and by means of Arm (REVERSE) (14), the head is caused to rotate in reverse direction.

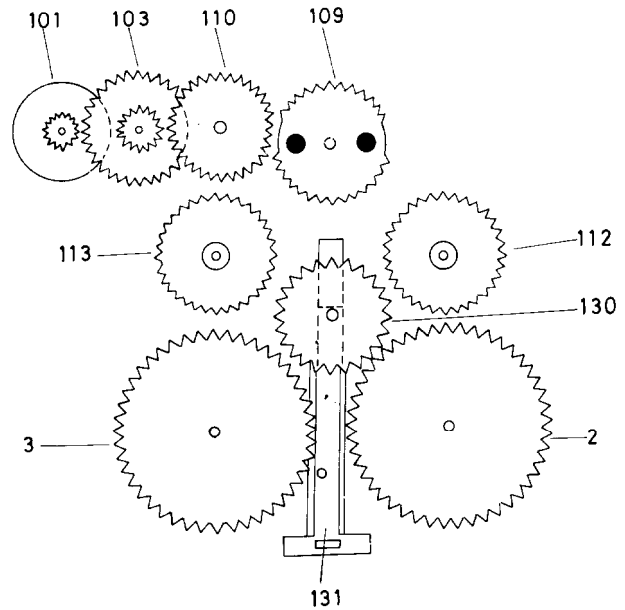
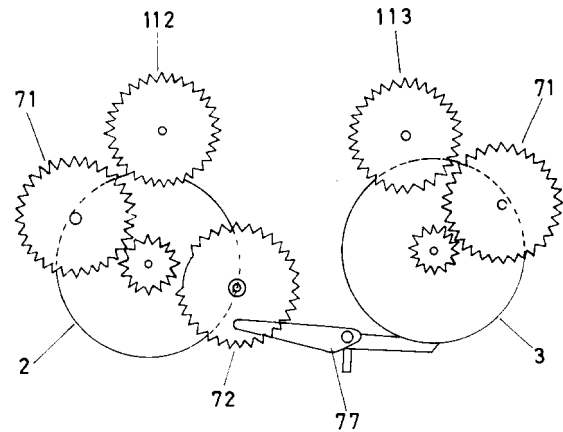
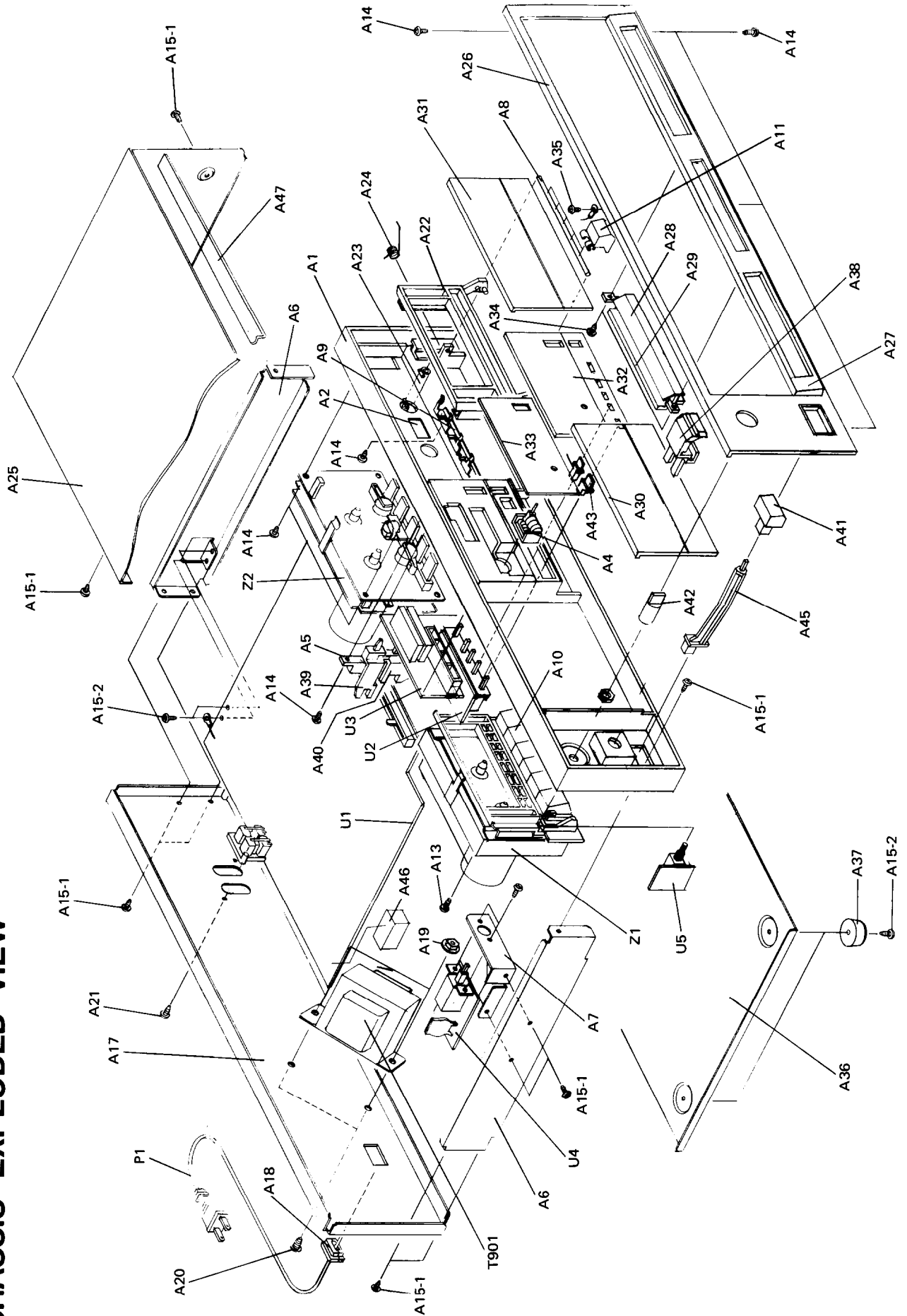

Fig-1



# CHASSIS-EXPLODED VIEW



# CHASSIS-EXPLODED VIEW-PARTS LIST

REF. NO.	PART NO.	DESCRIPTION	REF. NO.	PART NO.	DESCRIPTION
A1	27110287C	FRONT BRACKET	A28	27262293-1	PLATE (VR)
A2	27262412	PLATE (T2)	A29	27300831	RAIL (VR)
A3	27141086	BRACKET	A30	28400270A	CASSETTE LID ASS'Y (T1)
A4	24601203	TAPE COUNTER	A31	28400273A	CASSETTE LID ASS'Y (T2)
A5	27300830A	RAIL (T2)	A32	28191353A	CLEAR PLATE (C)
A6	27115168C	SIDE BRACKET (L)	A33	28133171A	BACK PLATE
A7	27140990A	BRACKET (POW)	A34	833430080	TAP-TIGHT SCREW 3TTP+8PBC
A8	27260219	SHAFT	A35	834230108	TAP-TIGHT SCREW 3TTS+10BN
A9	27180306B	SPRING (KNOB)	A36	27170229	BOTTOM BOARD
A10	28322545	KNOB (T1)	A37	27175003A	LEG
A11	28322544C	KNOB (T2)	A38	28322547	KNOB ASSY (VR)
A12	82143006	PAN-HEAD SCREW 3P+6FN BC	A39	28322548A	KNOB ASSY (MODE)
A13	831430100	TAP-TIGHT SCREW 3TTW+10P(BC)	A40	28322550A	KNOB ASSY (DIR)
A14	831430100	TAP-TIGHT SCREW 3TTW+10P(BC)	A41	28321905A	KNOB (POW)
A15-1	834430068	TAP-TIGHT SCREW 3TTS+6BBC	A42	28322028	KNOB (TONE)
A15-2	831130088	TAP-TIGHT SCREW 3TTW+8B	A43	28322552	KNOB (REC)
A16	833426060	TAP-TIGHT SCREW 2.6TTP+6P	A44	28322553	KNOB (SEL)
A17	27120888A	BACK PANEL	A45	27273030C	JOINT (L)
A18	27300750	BUSHING (CORD)	A46	28140397	CUSHION
A19	86414010	FLANGE NUT FWN4X10FN	A47	28140699	CUSHION
A20	830440109	TAP-TIGHT SCREW 4TTC+10CE	T901	A 2300110A	NPT-920D POWER TRANSFORMER
A21	834430108	TAP-TIGHT SCREW 3TTS+10BB	P1	A 253099C	AS-UC-3,POWER SUPPLY CORD
A22	27300834A	FRAME ASSY(CASSETTE)	Z1	244093	CASSETTE DECK MECHANISM,NDM-85(T1)
-1	24605334	SPRING (CASSETTE)	Z2	244094	CASSETTE DECK MECHANISM,NDM-86(T2)
-2	833420068	TAP-TIGHT SCREW 2TTP+6BBC	U1	15118502-1	NAAF-2702-1 MAIN PC BOARD ASSY
A23	24610994	DAMPER UNIT	U2	15118503-1	NASW-2703-1 TAPE SELECTOR SWITCH PC BOARD ASSY
A24	27180307	SPRING (FRAME)	U3	15118504-1	NADIS-2704-1 DISPLAY PC BOARD ASSY
A25	28184274B	TOP COVER	U4	15118505-1	NAPS-2705-1 POWER SWITCH PC BOARD ASSY
A26	15118121	FRONT PANEL ASS'Y	U5	15118506-1	NASW-2706-1 DOLBY SWITCH PC BOARD ASSY
A27	27215116B	COSMETIC FRAME			

NOTE: THE COMPONENTS IDENTIFIED BY MARK **A** ARE CRITICAL FOR RISK OF FIRE AND ELECTRIC SHOCK. REPLACE ONLY WITH PARTS NUMBER SPECIFIED.

# ADJUSTMENT PROCEDURES

## PRECAUTIONS

- Before adjustment, clean the following parts with an alcohol moistend swab.
  - \* record/playback head
  - \* pinch roller
  - \* erase head
  - \* capstan
- Do not use magnetized screwdriver for adjustments.
- Demagnetize record/playback head with a head demagnetizer.

## TEST EQUIPMENT/TOOLS REQUIRED:

Audio oscillator  
Digital frequency counter

Oscilloscope

Attenuator

AC voltmeter

Non-magnetic screw driver

Blank tapes (completely erased)

NORMAL . . . . . NEW UD90  
HIGH . . . . . NEW XL-II90  
METAL . . . . . NEW MX60

Test tapes

VTT-658 : 10 KHz, -15dB  
MTT-111 : 3 kHz, -10dB  
MTT-150 : Dolby level calibration  
400Hz, tone 200nWb/m

Item	Connection of instrument	Line input	Test tape	Mode	Output indicator	Adjustment point	Adjust	Remarks	
1	Frequency counter to LINE output terminal		MTT-111	T-1 H.speed	Frequency counter	<del>R647</del>	6.010 ± 10Hz	High speed connect the TP-3 to GND	
				N.speed		R643	3.005 ± 5Hz		
				T-2 H.speed		<del>R648</del>	6.020 ± 10Hz -		
				N.speed		R644	3.015 ± 5Hz		
2	Head azimuth	AC voltmeter and oscilloscope to LINE output terminal	VTT-658	PB	AC voltmeter	Haed azimuth screw	Maximum and same phase at channels L and R	See fig.1	
3	Playback level	AC voltmeter to terminals TP-1 and TP-2	MTT-150	PB	AC voltmeter	T-1 R-119.R-120 T-2 R-151.R-152	580mV		
4	Bias current	Fig.2	1KHz,-20dB and 12khz,-20dB	NEW XL-II90	T-1 REC/PB	AC voltmeter	R-441 (Ch.L) R-442 (Ch.R)	Same level at REC/PB	Input VR maximum
5	Record level	Fig.2	1 KHz	REC PAUSE	AC voltmeter	Attenuator or AF OSC output	350mV	Input VR maximum	
				REC/PB	AC voltmeter	R-407 (Ch.L) R-408 (Ch.R)	Same level at REC/PB		
6	Bias OSC frequency	Frequency counter to C-431 fig-3		T-1 REC		L-407	85kHz±2kHz	10:1 Cable	

PLAY torque . . . . .30~70g/cmm  
FF. REW torque . . . . .70~160g/cm  
Back tention . . . . .1.5~5g/cm

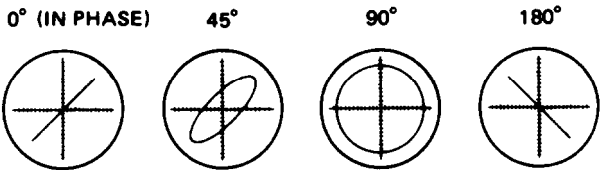
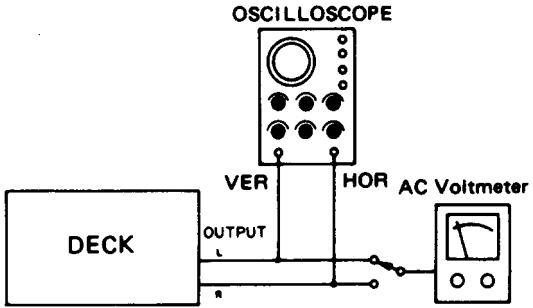
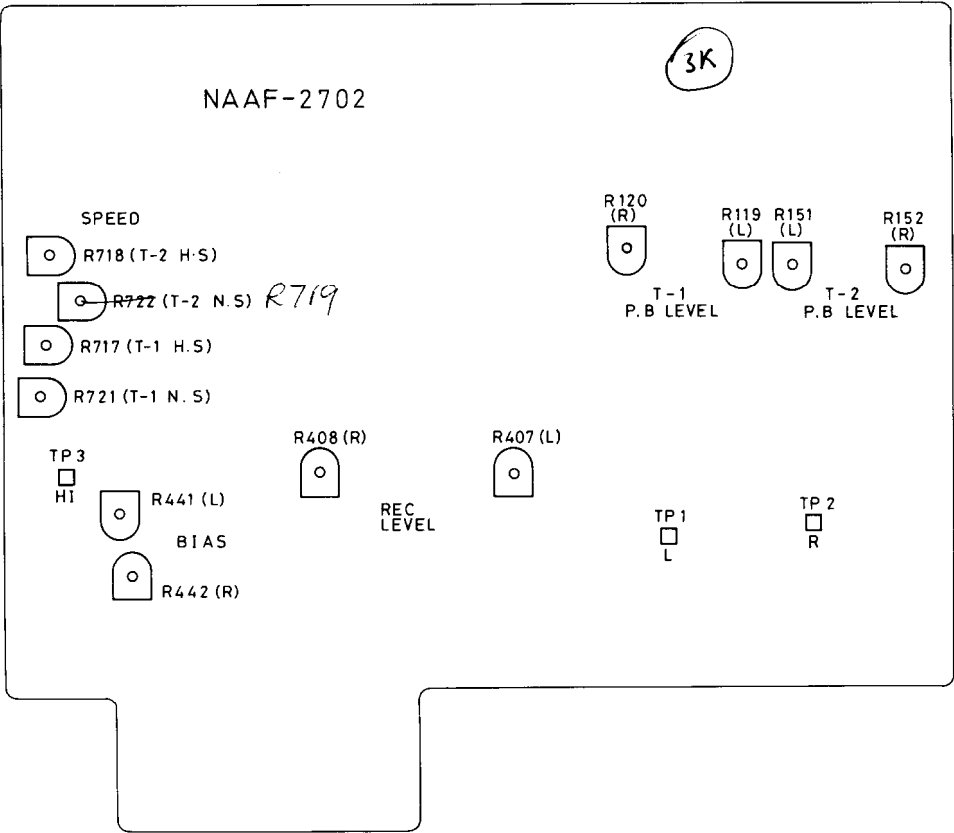

Confirming phase relationship  
fig-1

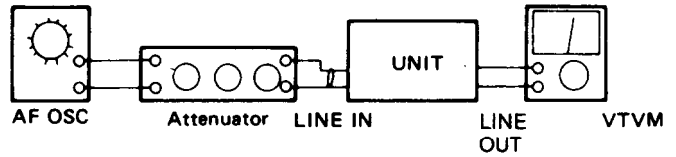

fig-2

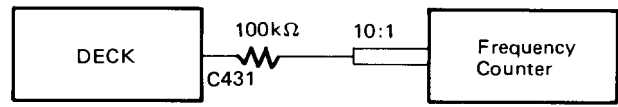
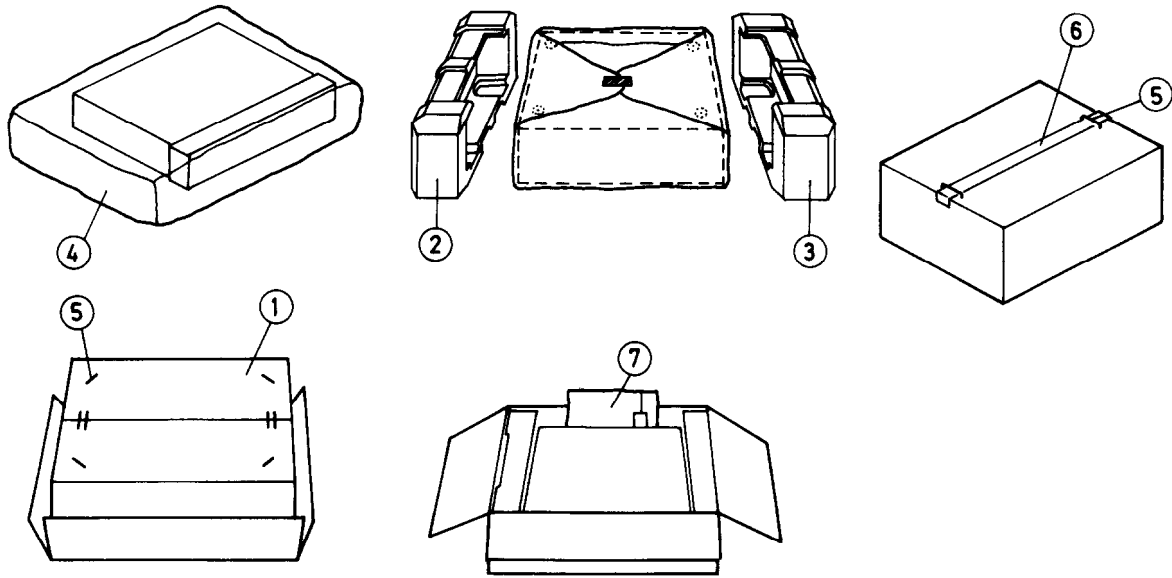

fig. 3

# PACKING VIEW



REF NO.	PART NO.	DESCRIPTION
1	29051335A	Master carton box
2	29090947A	Pad (L)
3	29090946A	Pad (R)
4	29100037A	650 X 500 Poly bag
5	282301	Sealing hook
6	260012	Damplon tape
7	Accessory bag ass'y	
	29341025	Instruction manual
	2010095	Connection cable
	29365006-7	Waranty card (N)
	29358002D	Service station list (N)
	29100006A	350 X 250 Poly bag

NOTE  
(N): USA Model

# PC BOARD PARTS LIST

## MAIN CIRCUIT PC BOARD (NAAF-2702-1)

CIRCUIT NO.	PARTS NO.	DESCRIPTION	CIRCUIT NO.	PARTS NO.	DESCRIPTION
	ICS		D611	223150,	US1040,
Q101,Q102	222956	NJM2068DD		223124 or	1S2473 or
Q133,Q134	222956	NJM2068DD		223145	1S2076TD
Q201,Q202	222811 or	NJM4558DD or	D612,D613	223163 or	1SS133 or
	222502	NJM4558DX		223155	1SS138
Q205,Q206	222808 or	M5218P or	D614	223132	1K60
	222921	BA4558	D701,D702	223163 or	1SS133 or
Q211,Q212	222635	TA7629P		223155	1SS138
Q403,Q404	222808	M5218P	D706,	223163 or	1SS133 or
Q416	222918	BA6251	D708,D709	223155	1SS138
Q902	222780122	78M12	D710	223150,	US1040,
Q903	222790122	79M12		223124 or	1S2473 or
				223145	1S2076TD
	TRANSISTORS		D901,D902	223842 or	GP15B or
Q103-Q106,	2211255 ,	2SC1815GR,		223891	RL152
Q131,Q132,	2210746 or	2SC945AP or	D903	2239651 or	RD13EB1 or
Q135,Q136	2212485	JC501Q		2243241	MTZ13A
Q137,Q138	2211705 or	2SD655E or	D904	223862 or	WL01 or
	2211706	2SD655F		223890	W01RL
Q203,Q204	2211255 ,	2SC1815GR,			
	2210746 or	2SC945AP or		COILS	
	2212485	JC501Q	L201,L202	233340	NMC-6053
Q207-Q210	221299	DTC114TS	L401,L402	231040,	NCH-2080,
Q213,Q214	2211705,	2SD655E,		24606072 or	NCH-1010 or
	2211706,	2SD655F,		231085	NCH-2133
	2211794 or	2SD1468R or	L403,L404	231036,	NCH-2076,
	2212795	2SD1468S		24606068 or	NCH-1006 or
Q215,Q216	2211255 or	2SC1815GR or	L405,L406	231081	NCH-2129
	2210746	2SC945AP		233283 or	NCH-4060 or
Q401,Q402	2211255 ,	2SC1815GR,		233314	NCH-2097
	2210746 or	2SC945AP or			
	2212485	JC501Q		OSC BLOCK	
Q405-Q412	2212304 or	2SK381D or	L407	231104	NLO-2044
	2211945	2SK246GR			
Q413,Q414	2211544	2SC1959Y		CAPACITORS	
Q415	2211454 or	2SA1015Y or	C105,C106	354734709	47 $\mu$ F,10V,Elect.
	2212494	JA101P	C113-C116	354780109	1 $\mu$ F,50V,Elect.
Q601-Q603	2211255,	2SC1815GR,	C137,C138	354734709	47 $\mu$ F,10V,Elect.
	2210746 or	2SC945AP or	C145-C148	354780109	1 $\mu$ F,50V,Elect.
	2212485	JC501Q	C201-C204	354784799	0.47 $\mu$ F,50V,Elect.
Q604	2212454 or	2SA1015Y or	C213-C214	354741009	10 $\mu$ F,16V,Elect.
	2212494	JA101P	C215,C216	354742219	220 $\mu$ F,16V,Elect.
Q605-Q611	2211255,	2SC1815GR,	C221,C222	354781099	0.1 $\mu$ F,50V,Elect.
	2210746 or	2SC945AP or	C223,C224	354783399	0.33 $\mu$ F,50V,Elect.
	2212485	JC501Q	C227-C230	354741009	10 $\mu$ F,16V,Elect.
Q701,Q702	2211454 or	2SA1015Y or	C233,C234	354741009	10 $\mu$ F,16V,Elect.
	2212494	JA101P	C403,C404	354781099	0.1 $\mu$ F,50V,Elect.
Q703	2211255,	2SC1815GR,	C405,C406	354741009	10 $\mu$ F,16V,Elect.
	2210746 or	2SC945AP or	C439	370131234	0.012 $\mu$ F,100V,APS.
	2212485	JC501Q	C440	354780109	1 $\mu$ F,50V,Elect.
Q901	2201074 or	2SD880Y or	C602	354742219	220 $\mu$ F,16V,Elect.
	2201385	2SD330E	C603	354741009	10 $\mu$ F,16V,Elect.
	DIODES		C605	354780109	1 $\mu$ F,50V,Elect.
D401,D402	223163 or	1SS133 or	C608	354780109	1 $\mu$ F,50V,Elect.
	223155	2SS138	C510,C511	354780109	1 $\mu$ F,50V,Elect.
D601,D602	223150,	US1040,	C902	354754719	470 $\mu$ F,25V,Elect.
	223124 or	1S2473 or	C903,C904	370141019	100 $\mu$ F,16V,Elect.
	223145	1S2076TD	C906	354752229	2200 $\mu$ F,25V,Elect.
D603-D609	223163 or	1SS133 or	C907	354754719	470 $\mu$ F,25V,Elect.
	223155	1SS138	C908,C909	354784799	0.47 $\mu$ F,50V,Elect.
			C910-C914	354744709	47 $\mu$ F,16V,Elect.

**POWER SWITCH PC BOARD (NAPS-2705-1)**

CIRCUIT NO.	PARTS NO.	DESCRIPTION
RESISTORS		
R119,R120, R151,R152	5215046 or 5215023	N08HR50kBC,Semi-fixed
R407,R408	5215046 or 5215023	N08HR50kBC,Semi-fixed
R441,R442	5215024 or 5215047	N08HR100kBC,Semi-fixed
R717,R718, R721,R722	5210060	N06HR2.2kBC,Semi-fixed
R202,R204	6142034	N60LGL50kA,Variable
R443	441521004	10 $\Omega$ ,1/2W,Oxidefilm
R449	441521214	120 $\Omega$ ,1/2W,Oxidefilm
R450	441521024	1k $\Omega$ ,1/2W,Oxidefilm
R451	441528214	820 $\Omega$ ,1/2W,Oxidefilm
R901	441520224	2.2k $\Omega$ ,1/2W,Oxidefilm
R902	441523314	330 $\Omega$ ,1/2W,Oxidefilm
R723,R724	4000103	LT3600V4S,1.2k,LPTC-R

## MISCELLANEOUS

RL601	25065174	NRL-2P1A DC12-09,Relay
P101	25055136	NPLG-6P-120,Plug
P102	25055134	NPLG-4P-118,Plug
P103	25055132	NPLG-2P-116,Plug
P701	25055139	NPLG-9P-123,Plug
P702	25055141	NPLG-11P-125,Plug
P601	25045084	NPJ-4PDBL-42,Pin jack
	27150189	Shield plate
	27160029	RD-07,Radiator
	27160029-1	RD-07B,Radiator
	82143006	3P+6FN(BC),Screw

**TAPE SELECTOR SWITCH PC BOARD (NASW-2703-1)**

CIRCUIT NO.	PARTS NO.	DESCRIPTION
SWITCH		
S601-S605	25035527	NPS-332-122-122-L489,Push

**DISPLAY PC BOARD (NADIS-2704-1)**

CIRCUIT NO.	PARTS NO.	DESCRIPTION
ICS		
Q301	222965	IR2E24
LEDS		
D301	225165	SEL-9520MB02
D711,D712	225134	GL-3NG1
D713-D716	225126	GL-3PR1
CAPACITORS		
C301	353750479	4.7 $\mu$ F,25V (S),Elect.
C302	353741009	10 $\mu$ F,16V (S),Elect.
HOLDER		
	27190460	HOLDER(LED-5)
	27190461A	HOLDER(LED-2)

CIRCUIT NO.	PARTS NO.	DESCRIPTION
CAPACITOR		
C901	3500065A	0.01 $\mu$ F,400,IS.
SWITCH		
S901	25035375	NPS-111-L339P,PUSH

**DOLBY SWITCH PC BOARD (NASW-2706-1)**

CIRCUIT NO.	PARTS NO.	DESCRIPTION
S301	25030283	NPS-122-25SBM,SWITCH

# TAPE MECHANISM PARTS LIST (TAPE-1)

REF.NO.	PARTS NO.	DESCRIPTION	REF.NO.	PARTS NO.	DESCRIPTION
1	24611151	CASSETTE CASE	65	24611164	HOLDER (GEAR)
2	24605334	SPRING (CASSETTE)	66	24611274	OIL SEAL
3	24611236	BACK PLATE (CASSETTE)	67	24601206	MOTOR AS (67+70)
4	24604073	SHAFT (BUTTON)	68	24611165	PLATE (MOTOR)
6	24605566	SPRING	69	24610723	CUSHION
7	24611087	BUSHING	70	24602394	PULLEY
8	24611152	FELT WASHER	71	24602334	ARM (F.R. IDLER)
9	24600060	R/P HEAD	72	24605576	SPRING
10	24600041	E HEAD	73	24602335	ASSIST GEAR (A)
11	24605136	SPRING	74	24602336	ASSIST GEAR (B)
12	24611153	HEAD BASE	75	24605577	SPRING
13	24605567	SPRING	76	24603318	LEVER (P CAM)
14	24603307	LEVER (F.R.)	77	891035	STOP RING 3.5
15	863120	NUT M2	78	24606253	LEAF SWITCH
16	24602322	IDLER AS (P)	79	24603319	LEVER (CR CAM)
17	24605568	SPRING	80	24605578	SPRING
18	24603308	LEVER (RESET)	81	24603320 <sup>4</sup>	LEVER (FR START)
19	24611170	WASHER	82	24603343	LEVER (FRS)
20	24602323	TAKE UP REEL AS	83	24611166	PLATE (PROTECT)
21	24611154	INTER LOCK PLATE	84	24605579	SPRING
22	24602390	CAP (REEL)	85	24611167	PLATE (REC JOINT)
23	24603309	LEVER (FR UNLOCK)	86	24605580	SPRING
24	24605569	SPRING	87	24611273	SWITCH PLATE
25	24603310	LEVER (P.UNLOCK)	88	24606254	LEAF SWITCH
26	24611155	LOCK PLATE (PL)	89	24605581	SPRING
27	24605570	SPRING	90	24611168	PLATE (REC CHANGE)
28	24611156	LOCK PLATE (FR)	91	24603322	LEVER (PL START)
29	24611272	DAMPER AS	93	24605582	SPRING
30	24611158	PLATE (REC COVER)	94	24611169	HOLDER (DAMPER)
31	24605644	SPRING	96	24603324	LEVER (RSW)
32	24605572	SPRING	99	24602371	BELT (COUNTER)
33	24602325	GEAR (F IDLER)	100	873120	WASHER
34	24602326	CAM (SENSOR)	101	24611118	LUG
35	24602327	GEAR (A.S.)	102	24606255	LUG TERMINAL
36	24611159	HOLDER (CASSETTE)	103		NYLON BAND
37	24602328	CAM (EJECT)	105		CONNECTOR AS
38	24603311	LATCH LEVER	106		CONNECTOR AS
39	24602329	PINCH ROLLER AS	107		CONNECTOR AS
40	24605573	SPRING	108		WIRE
41	24606226	LUG	109		WIRE
42	24605574	SPRING	110		WIRE
43	24602391	GEAR (SUPPLY REEL)	111		WIRE
44	24611163	MECHANISM CHASSIS	201	838120055	TAPPING SCREW,M2X5
45	24603312	LEVER (SE)	202	838120085	TAPPING SCREW,M2X8
46	24603313	LEVER (PAUSE)	203	82512010	SCREW,M2X10
47	24603314	LEVER (FF)	204	831126062	TAPPING SCREW,2.6STW+6 BQ
48	24603315	LEVER (REW)	205	801353	SCREW (MOTOR)
49	24603342	LEVER (PL) B	206	82112604	PAN-HEAD SCREW,2.6P+4F
50	24603317	LEVER (REC)	208	831126085	TAPPING SCREW,M2.6X8
52	24605575	SPRING	209	82112605	PAN-HEAD SCREW
55	24604074	SPACER	210	82111706	SCREW,M1.7X6
58	24611161	LOCK PIN	211	838126065	TAPPING SCREW,M2.6X6
59	24611162	CAPSTAN SUPPORT			
60	24602332	FLY WHEEL AS			
61	24602392	BELT			
62	24602393	BELT			
63	24606252	LEAF SWITCH			
64	24611171	WASHER			



# TAPE MECHANISM PARTS LIST (TAPE-2)

REF.NO.	PARTS NO.	DESCRIPTION	REF.NO.	PARTS NO.	DESCRIPTION
1	24605619	SPRING	107	24611264	SENSOR
2	24602373	FLYWHEEL AS (C)	108	24605634	SPRING
3	24602374	FLYWHEEL	109	24602383	CAM AS
4	24602375	BELT	110	24602384	GEAR (STOP)
5	24611238	METAL	111	24611265	ACTUATING PLATE (CLUTCH)
6	24611239	HOLDER (PAUSE)	112	24602385	REEL AS (F)
7	24611240	LOCK PIN	113	24602386	REEL AS (R)
8	24605620	SPRING	114	24611266	PLATE (SWITCH)
13	24611241	BASE AS (MECHANISM)	115	24611267	RELEASE PLATE
14	24607052	ARM (REVERSE)	116	24605635	SPRING
15	24607053	ARM AS (A) R	117	24603337	LEVER AS (RELEASE)
16	24607054	ARM AS (A) L	118	24611268	RELEASE PLATE (BUTTON)
17	24611242	SLIDE PLATE AS	119	24603338	LEVER AS (RELEASE) FR
18	24611243	ROCKING ARM	120	24611269	CONNECTING PLATE (EJECT)
19	24605621	SPRING	121	24605636	SPRING
20	24611244	BASE AS (HEAD)	122	24607061	ARM (RELEASE)
21	24604081	COLLAR	123	24605637	SPRING
22	24611245	LEAD CLAMPER	124	24603339	LEVER (DIR)
27	24611246	LEAD CLAMPER	125	24605638	SPRING
28	24611247	METAL	130	24607062	ARM (DRIVE)
29	24602376	GEAR (FW)	131	24607063	ARM (FR)
32	24600065	PB HEAD AS	132	24611270	SLIDE PLATE (FR)
35	24602388	GEAR (HEAD)	133	24603340	LEVER (MS SW)
36	24605622	SPRING	134	24603341	LEVER (B)
38	24605623	SPRING	135	24605639	SPRING
39	24611251	STOPPER	136	24604084	COLLAR
47	24606251	LEAF SWITCH	137	24604085	COLLAR
50	24611253	SLIDER (H)	138	24605640	SPRING
51	24605624	SPRING	140	24611271	BRACKET (FLYWHEEL)
52	24605625	SPRING	141	24610723	CUSHION
53	24603334	LEVER (SE)	142	24601207	MOTOR AS (139+142+307)
54	24603335	LEVER (EJECT)	150	24605641	SPRING
55	24611254	CAM (EJECT)	151	24605642	SPRING
66	24607055	P ARM AS (L)	152	24605643	SPRING
67	24605626	SPRING	201	833114067	PAN HEAD SCREW, M14×6
68	24607056	P ARM AS (R)	202	833117073	PAN HEAD SCREW, M17×3
69	24605627	SPRING	203	833117047	PAN HEAD SCREW, M3 × 5
70	24605628	SPRING	204	838120057	BIND SCREW,M2×5
71	24602378	GEAR (A)	205	833120057	PAN HEAD SCREW,M2×5
72	24602379	CAM (ASSIST)	206	831120067	PAN HEAD SCREW,M2×6
73	24607057	ASSIST ARM AS	207	838120085	BIND SCREW,M2×8
74	24605629	SPRING	208	801377	SCREW (MOTOR)
75	24607058	CHANGE ARM (REC)	209	833126047	PAN HEAD SCREW,M2.6×4
76	24605630	SPRING	210	838126057	BIND SCREW,M2.6×5
77	24611255	TRIGGER (ASSIST)	211	801378	TAPPING SCREW, M2×6
78	24611256	TRIGGER (PAUSE)	212	838126207	BIND SCREW,M2.6×20
79	24605631	SPRING	215	838120057	TAPPING SCREW,M2 × 5
80	24602380	CAM (PAUSE)	217	82112016	PAN HEAD SCREW,M2×16
81	24607059	CHANGE ARM (MODE)	301	24611278	WASHER,φ1.5 × φ4 × t0.2
83	24611258	BUTTON (PLAY)	302	24611279	WASHER,φ1.5 × φ4 × t0.2
84	24611259	BUTTON (F/R)	303	24611280	WASHER,φ3.5 × φ5 × t0.25
85	24611260	BUTTON (PAUSE)	304	24611281	WASHER,φ1.6 × φ4 × t0.2
86	24611261	BUTTON (S/E)	305	24611282	WASHER,φ2.0 × φ4 × t0.2
87	24605632	SPRING	306	24611283	WASHER,φ2.6 × φ4 × t0.25
88	24605633	SPRING	307	24611284	WASHER,φ1.9 × φ4 × t0.2
89	24606248	LEAF SWITCH	308	24611285	WASHER,φ2.0 × φ4 × t0.2
90	24606249	LEAF SWITCH	309	24611286	WASHER,φ2.4 × φ4 × t0.3
91	24606250	LEAF SWITCH	312	24611287	WASHER,φ2.2 × φ4 × t0.3
92	24603336	LEVER (PROTECT) A	314	24611288	WASHER
93	24604083	COLLAR	316	24611289	WASHER,φ2.4 × φ4 × t0.25
100	24611262	SUB CHASSIS	401	24611290	BUSHING
101	24602389	PULLEY AS (IDLER)	402	24611291	BUSHING
102	24602381	BELT	403	24611084	BUSHING
103	24602382	GEAR (IDLER)	501	893025	E2.5 CIRCLIP
104	24611263	TRIGGER			
105	24605531	SPRING (T)			
106	24607060	ARM (SENSOR)			