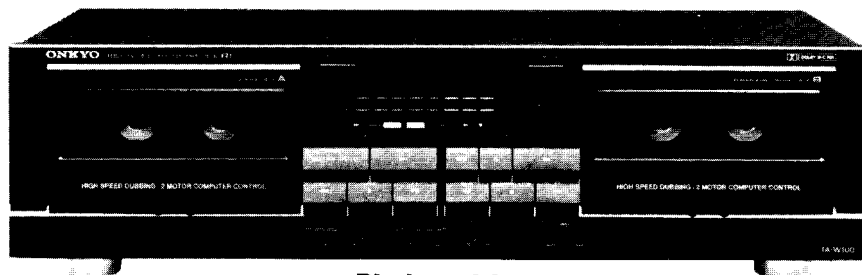

ONKYO SERVICE MANUAL**STEREO CASSETTE
TAPE DECK
MODEL TA-W100****Black model**

UD, UDN, UDC	120V AC, 60Hz
UW	120/220V AC, 50/60Hz

SAFETY-RELATED COMPONENT WARNING!!

COMPONENTS IDENTIFIED BY MARK \triangle ON THE SCHEMATIC DIAGRAM AND IN THE PARTS LIST ARE CRITICAL FOR RISK OF FIRE AND ELECTRIC SHOCK. REPLACE THESE COMPONENTS WITH ONKYO PARTS WHOSE PART NUMBERS APPEAR AS SHOWN IN THIS MANUAL.

MAKE LEAKAGE-CURRENT OR RESISTANCE MEASUREMENTS TO DETERMINE THAT EXPOSED PARTS ARE ACCEPTABLY INSULATED FROM THE SUPPLY CIRCUIT BEFORE RETURNING THE APPLIANCE TO THE CUSTOMER.

ONKYO.
AUDIO COMPONENTS

SPECIFICATIONS

Track System:	4-tracks, 2-channels
Erasing System:	AC erase
Tape Speed:	4.8 cm/sec. (1-7/8 i.p.s.) 9.6 cm/sec. (3-3/4 i.p.s.) (high speed dubbing)
Wow and Flutter:	0.07% (WRMS)
Frequency Response:	20-15,000Hz (Normal) (30-14,000Hz \pm 3dB) 20-16,000Hz (High) (30-15,000Hz \pm 3dB) 20-17,000Hz (Metal) (30-16,000Hz \pm 3dB)
S/N Ratio:	Dolby NR off: 58dB (metal position tape) A noise reduction of 10dB above 5kHz and 5dB at 1kHz is possible with Dolby B NR. A noise reduction of 20dB at 5kHz is possible with Dolby C NR.
Input Jacks:	Line IN: 2 Input sensitivity: 60mV Input impedance: 50 kohms
Outputs:	Line OUT: 2 Standard output level: 500mV (0dB) Optimum load impedance: over 50 kohms
Motors:	DC servo motor \times 2; DC motor \times 2
Heads:	REC/PB: special hard permalloy \times 2; Erase head: ferrite \times 1
Power Supply Rating:	U.K. and Australian models: AC 240V, 50Hz U.S.A. and Canadian models: AC 120V, 60Hz Worldwide models: AC 120V and 220V switchable, 50/60Hz
Power Consumption:	29 watts
Dimensions:	435(W) \times 122(H) \times 258(D)mm (17-1/8" \times 4-13/16" \times 10-3/16")
Weight:	4.8kg (10.6 lbs.)

Specifications and external appearance are subject to change without notice because of product improvements.

SERVICE PROCEDURES

1. Replacement of power supply cord

There are two power supply cord outlets on the strainrelief. Insert them in prescribed direction to ensure safety. AS-UC-3 (UD<120V> model) should be inserted lengthwise and other types of cords should be inserted horizontally.

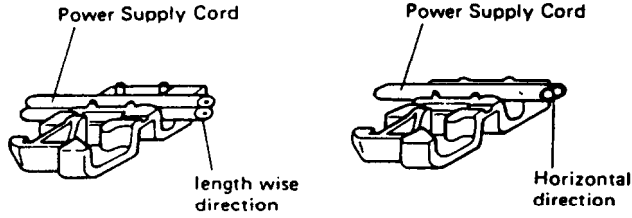

2. Insulating resistance measurement

Connect the insulating-resistance tester between the plug of power supply cord and chassis. Specifications: 500V more than 10MΩ

IC BLOCK DIAGRAM

NHIC-3205 (P.B. AMP)

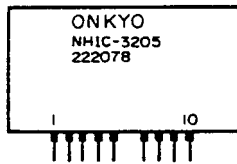
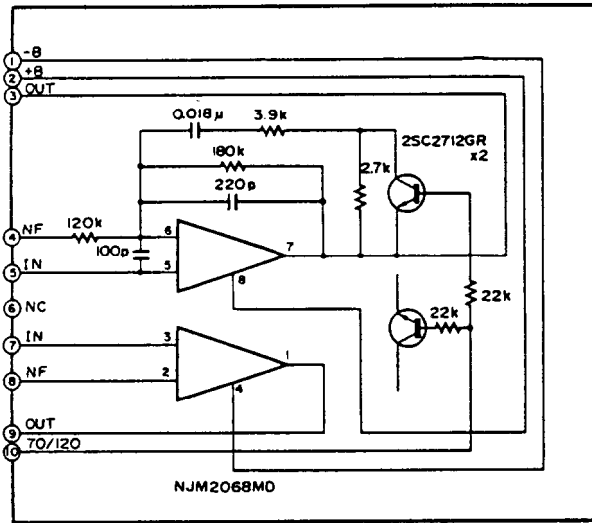

IR2E02 (LEVEL METER DRIVE)

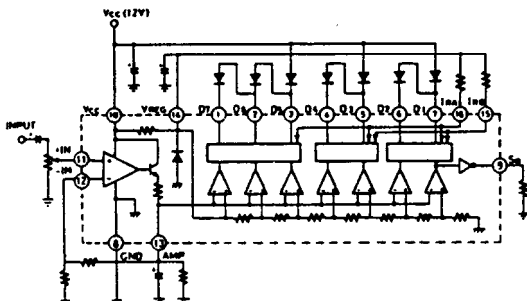

CXA1331S (DOLBY NR)

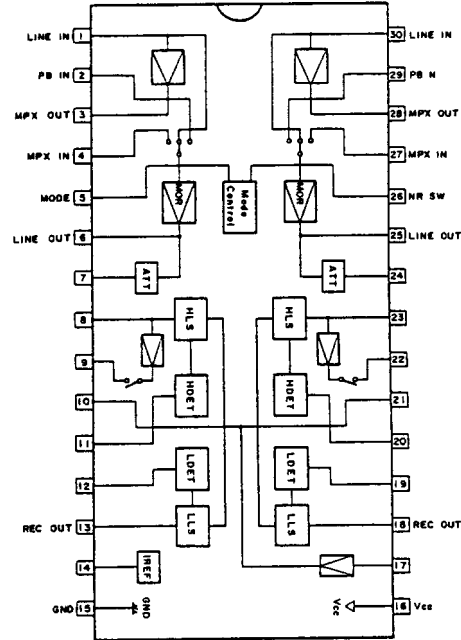

TA7291S (MOTOR DRIVE)

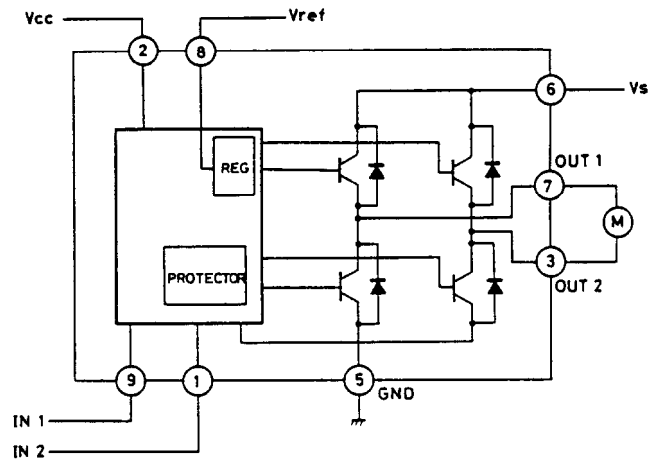

INPUT		OUTPUT		MODE
IN 1	IN 2	OUT 1	OUT 2	
0	0	∞	∞	STOP
1	0	H	L	CW/CCW
0	1	L	H	CCW/CW
1	1	L	L	BRAKE

BLOCK DIAGRAM

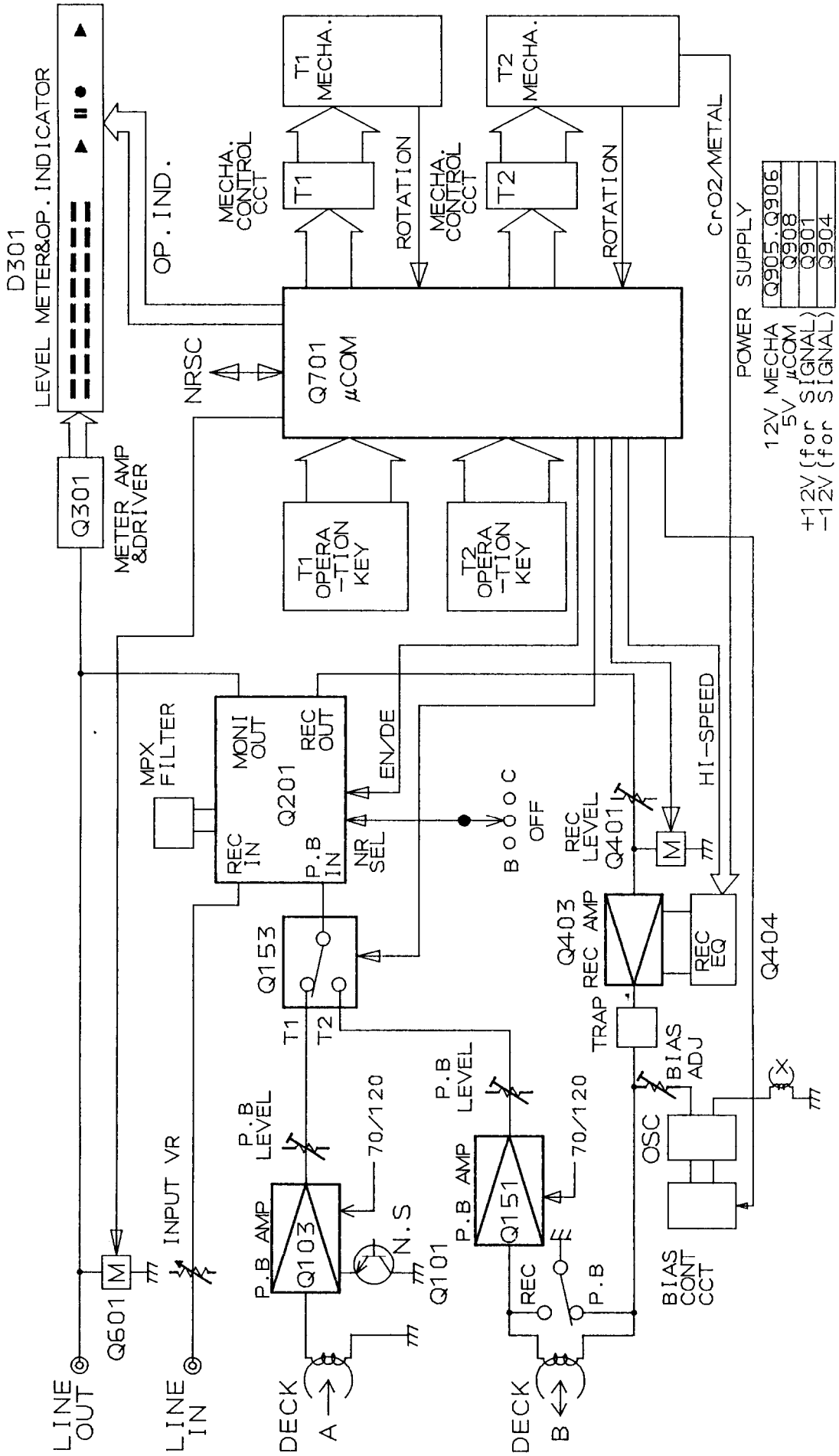

12V MECHA	Q905, Q906
5V μCOM	Q908
+12V (for SIGNAL)	Q901
-12V (for SIGNAL)	Q904

LS-0241 (DISPLAY TUBE)

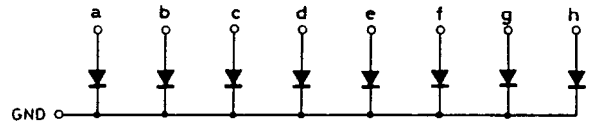
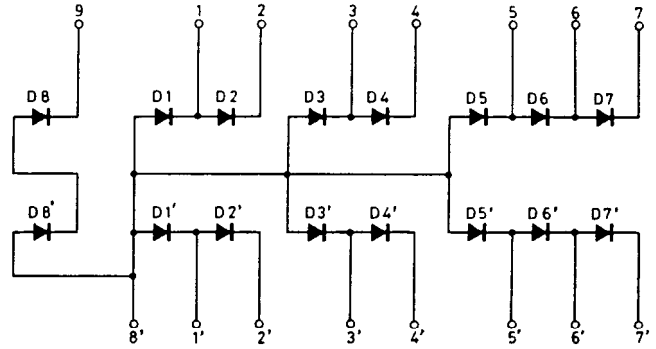
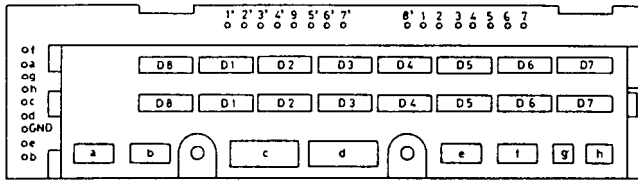

D1 ~ D4, D8, D1' ~ D4', D8'; a, b, e, f, ----- GRN
 D5 ~ D7, D5' ~ D7'; c, d, g, h, ----- RED

PACKING VIEW

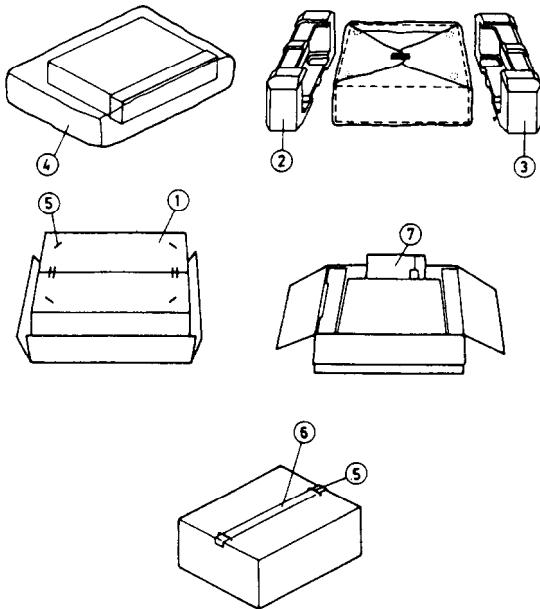

REF NO.	PART NO.	DESCRIPTION
1	29052036	Master carton box
2	29091235A	Pad (L)
3	29091236A	Pad (R)
4	29100037A	650×650 Poly bag
	29095378	Protection sheet
5	282301	Sealing hook
6	260012	Damplon tape
7	Accessory bag ass'y	
	29341500B	Instruction manual
	2010098A	Connection cable
	29365019	Waranty card (N)
	29358002G	Service station list (N)
	29100006A	350×250 Poly bag
	25055018	Conversion plug (CV-K-2) (W)

NOTE (N) : Only U.S.A. Model
 (W) : Only 120V/220V models

MECHANISM OPERATION

The mechanism in this set uses the power of a capstan motor to move the head up and down. It has one capstan motor, one reel motor and one solenoid.

The mechanism has three operating modes FWD PLAY, REV PLAY and STOP. The operating mode is selected by the solenoid timing. Typical timings are shown in fig. 2.

This mechanism is designed so that the solenoid is continuously held back in PLAY mode, so there is no longer any need to fit a PLAY switch for detecting head rise. When the solenoid stops being held back, the mechanism stops. This allows the mechanism to be initialized when the power is switched on by turning the capstan motor without holding back the solenoid. This allows that the mechanism to be returned to STOP mode, regardless of what state it was in when it was stopped.

FF and REW are handled by rotating the reel motor at high speed in STOP mode. Holding back the solenoid when moving from STOP to PLAY takes some time, and the mechanism is structured to allow this. This is done because the capstan motor is designed to rotate at a constant speed. For double speed dubbing the capstan motor speed is switched when PLAY finishes.

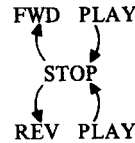
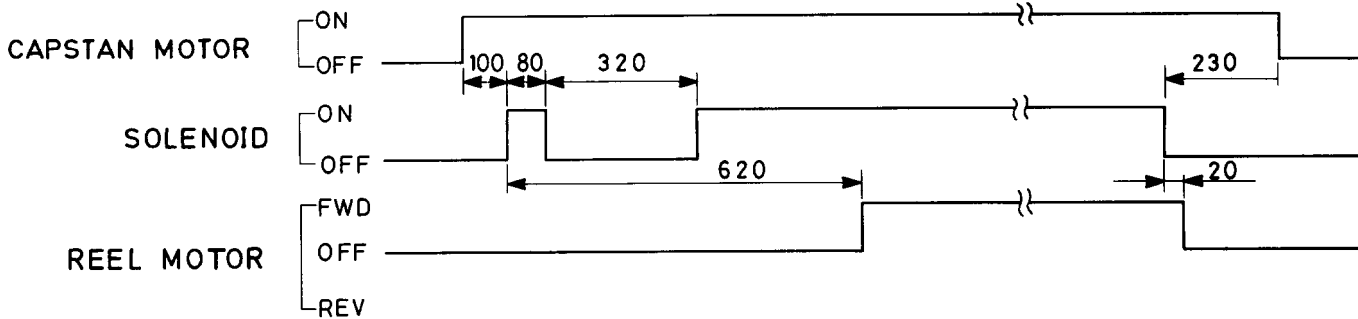

Fig. 1 mechanism operating modes

STOP → FWD · PLAY → STOP



STOP → REV · PLAY → STOP

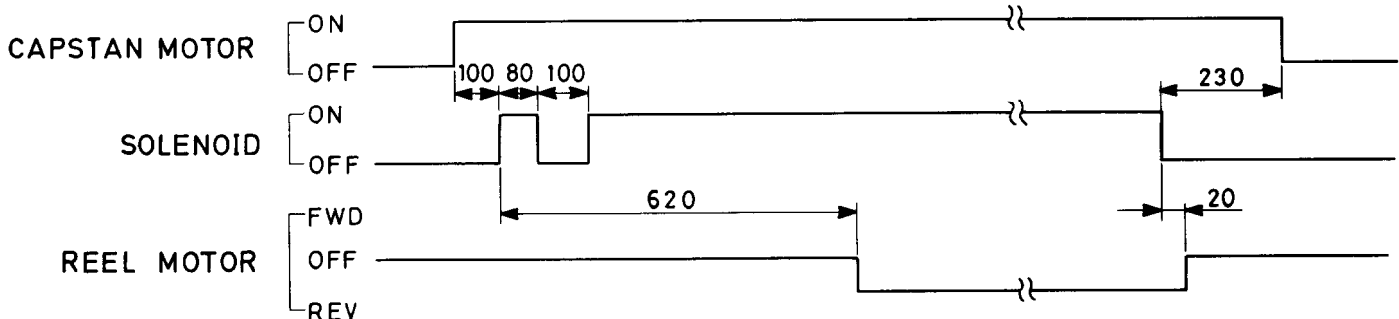

Fig. 2 Typical timings for PLAY modes

MICRO COMPUTER PORT NAMES AND FUNCTION

(HD614049SA26)

Pin No.	Pin	Function	Port
1	×2 DUBB	Double speed dubbing display output	D
3	T1.PLAY	T1 direction display output	D
4	REC. MUTE	Record muting output	D
5		Not used (dropped to earth by resistance)	D
6	INPUT SEL. T2/T1	Input signal select output T2 selected by logical 1, T1 selected by logical 0	D
7	BIAS CONT.	Bias oscillator control output (Service documentation)	D
8	T2 REC/PB	Audio record/playback output	D
9	SPEED ×1/×2	Capstan motor speed signal output. (for selecting audio line)	D
10~17		Control key switch inputs	D
18	T1 ROTATION SENSOR	T1 rotation signal input (for tape end sensing)	D
19	T2 ROTATION SENSOR	T2 rotation signal input (for tape end sensing)	D
20	T2 METAL POSITION	T2 Tape type sensor switch input (for detecting metal tape)	B
21	T2 SIDE-A REC. INH	T2 Side A record inhibit pit sensor switch input	B
22	T2 CASSETTE IN	T2 cassette tape sensor switch input	B
23	T2 HIGH POSITION	T2 Tape type sensor switch input (for detecting chrome tape)	B
25	T1 CASSETTE IN	T1 cassette tape sensor switch input	B
26	CONTINUOUS ON/OFF	Continuous play ON/OFF switch input	B
27	P-OFF	Power off detection input	A
28, 29	CAP CONT ON/OFF	T1, T2 capstan rotation control output	C
30, 31	×2/×T	T1, T2 capstan speed control output (Service documentation)	C
32	VCC	Power terminal (+5V)	
33	NRSC IN	Serial code reciprocal control signal input	A
34	NRSC OUT	Serial code reciprocal control signal output	B
35	LINE MUTE	Line muting output Not used	B
36		(Connected to GND)	A
37, 41	FF.	T1, T2 reel motor FF rotation control output	C
38, 42	REW	T1, T2 reel motor REW rotation control output	C
39, 43	O-PLAY	T1, T2 reel motor rotation torque control output	C
40, 44	SOL.HOLD	T1, T2 solenoid hold output	B
45~48		Control key switch inputs	B
49	SYSTEM RESET	Microprocessor reset input	
50	TEST	Microprocessor internal test terminal (connected to VCC)	
51, 52	OSC	Clock oscillator pin	
53	GND	Power terminal	
54~56	TAPE.SEL	Tape type select output (for selecting audio line)	
57	DOLBY DEC/ENC	Dolby circuit encode/decode select output (Service documentation)	
58, 59	SOLENOID ON/OFF	T1, T2 solenoid hold time power up output	
60	T2 PLAY	T2 direction display output	
62	T2 REC	T2 recording display output	
63	T2 PAUSE	T2 recording pause display output	
64	DUBBING	Constant speed dubbing display output	

① Ports:

A: NMOS open drain. No pull-up MOS

B: NMOS open drain. With pull-up MOS

C: CMOS output

D: PMOS open drain. No pull-down MOS

MICRO COMPUTER (HD614049SA26)

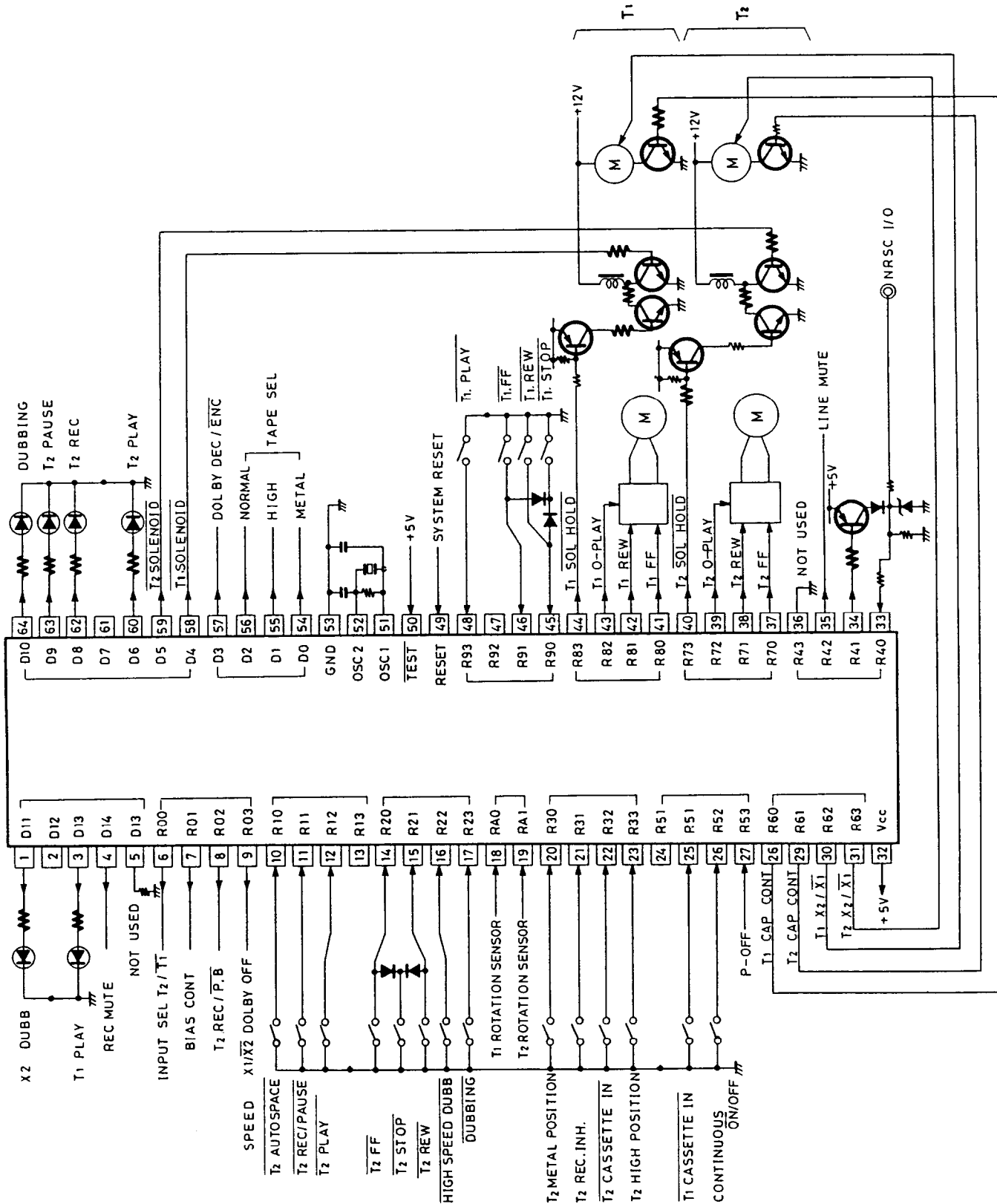

CHASSIS-EXPLODED VIEW

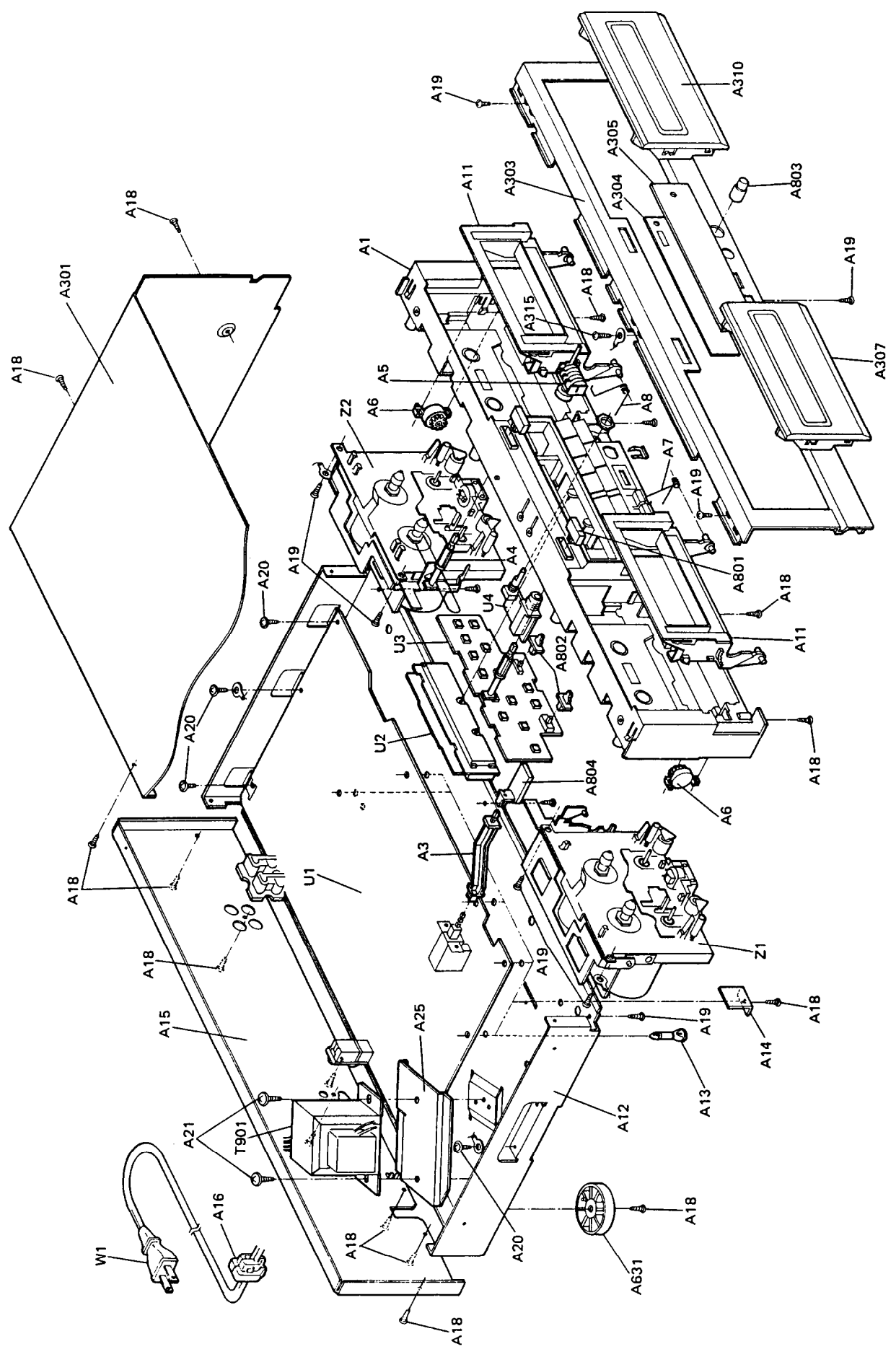

CHASSIS-EXPLODED VIEW PARTS LIST

REF. N ^o .	PART NO.	DESCRIPTION
A1	27110548B	FRONT BRACKET AS
A3	27273117	JOINT (POW)
A4	27273042B	JOINT (EJ)
A5	24601220	TAPE COUNTER
A6	28400282	DAMPER
A7	27180332-1	SPRING (T1)
A8	27180333-1	SPRING (T2)
A11	28400473B	FRAME AS (CASSETTE)
-a	28400463A	FRAME
-b	27180272A	SPRING (CA)
A12	27100184C	CHASSIS
A13	27190266	HOLDER
A15	27121327	BACK PANEL (D)
	27121327-1	BACK PANL (W)
A16	27300750	BUSHING (CORD)
A18	834430088	TAP-TIGHT SCREW 3TTS+8B (BC)
A19	833430080	TAP-TIGHT SCREW 3TTP+8P (BC)
A20	831130088	TAP-TIGHT SCREW 3TTW+8B
A21	830440089	TAP-TIGHT SCREW 4TTC+8C (BC)
A25	27130585B	BRACKET (PT)
A301	28184433	TOP COVER
A303	27211168	FRONT PANEL
A304	28133242	BACK PLATE
A305	28191505	CLEAR PLATE
A307	28400551	CASSETTE LID AS (BA)
-a	28400549	CASSETTE LID (BA)
-b	28400468	WINDOW
A310	28400552	CASSETTE LID AS (BB)
-a	28400550	CASSETTE LID (BB)
-b	28400468	WINDOW
A315	838130108	TAP-TIGHT SCREW 3TTS+10B
A631	27175219C	LEG
A801	28322838A	KNOB (EJECT)
A802	28323669	KNOB (TIM)
A803	28323671A	KNOB (VOL)
A804	28323639	KNOB (POW)
T901	△ 2300403A	NPT-1026D (D)
	△ 2300405A	NPT-1026DG (W)
S902	△ 25065123	NSS-1258P (W)
U1	1N082505-2	NAAR-3805-2
U2	1N082507-2	NADIS-3807-2
U3	1N082506-2	NASW-3806-2
U4	1N082508-2	NAETC-3808-2
W1	△ 253099C	AC CORD(AS-UC3) (D)
	△ 253149	AC CORD(AS-CEE) (W)
Z1	244136	CASSETTE DECK MECHANISM (NDM-128)
Z2	244137	CASSETTE DECK MECHANISM (NDM-129)

NOTE: [D]: Only 120V models

[W]: Only 120V/220V models

NOTE: THE COMPONENTS IDENTIFIED BY MARK △ ARE CRITICAL FOR RISK OF FIRE AND ELECTRIC SHOCK. REPLACE ONLY WITH PARTS NUMBER SPECIFIED.

ADJUSTMENT PROCEDURES

PRECAUTIONS

- Before adjustment, clean the following parts with an alcohol moistened swab.
 - * record/playback head
 - * erase head
 - * pinch roller
 - * capstan
- Do not use magnetized screwdriver for adjustments.
- Demagnetize record/playback head with a head demagnetizer.

TEST EQUIPMENT/TOOLS REQUIRED:

Audio oscillator
 Digital frequency counter
 Oscilloscope
 Attenuator
 AC voltmeter
 Non-magnetic screw driver
 Test tapes
 VTT-658 : 10 KHz, -15dB
 MTT-111 : 3 kHz, -10dB
 MTT-150 : Dolby level calibration
 400Hz, tone 200nWb/m

Item	Connection of instrument	Line input	Test tape	Mode	Output indicator	Adjustment point	Adjust	Remarks
1	Tape speed	Frequency counter to LINE output terminal	MTT-111	PB	Frequency counter	T1 Normal R868 T1 High R865 T2 Normal R820 T2 High R817	3010±10Hz 6020±10Hz 3010±10Hz 6020±20Hz	High speed connect the TP-6(T1)to GND TP-5(T2)to GND High speed first
2	Head azimuth	AC voltmeter and oscilloscope to LINE output terminal	VTT-703L	PB	AC voltmeter	Head azimuth screw	Maximum and same phase at channels L and R	fig-1
3	Playback level	AC voltmeter to terminals TP-1 and TP-2	MTT-150	PB	AC voltmeter	T1 R105 (Ch. L) T1 R106 (Ch. R) T2 R155 (Ch. L) T2 R156 (Ch. R)	388mV	
4	OSC Block	Frequency counter to P401 read loose coupling	T2 METAL TAPE MX-C90	T2 REC	Frequency counter	L-463	85kHz±2kHz	
5	Bias current	fig-2	1kHz, -20dB and 12kHz, -20dB	XL-II C-90	REC/PB	AC voltmeter R463 (Ch. L) R464 (Ch. R)	Same level at REC/PB	Input VR maximum.
6	Record level	fig-2	1kHz	XL-II C-90	REC	AC voltmeter Attenuator or AF OSC output	350mV	
					REC/PB	AC voltmeter R405 (Ch. L) R406 (Ch. R)	Same level at REC/PB	

Blank tape

NORMAL UD-1 C-90

HIGH XL-II C-90

METAL MX C-90

PLAY torque 30~70g/cm

FF. REW torque 80~180g/cm

Back tension 2~7g/cm

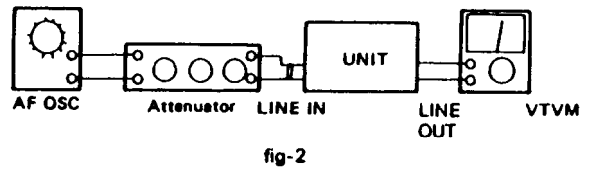
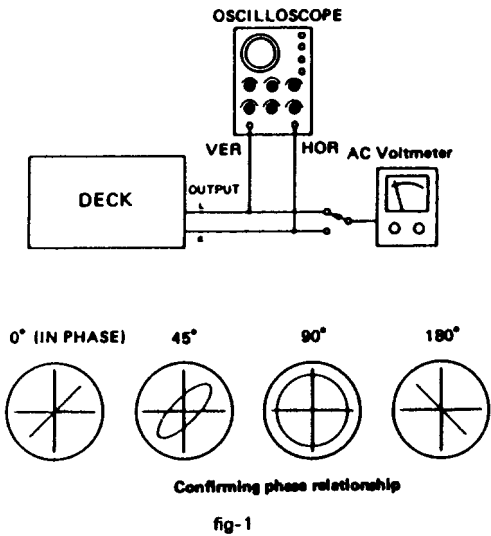
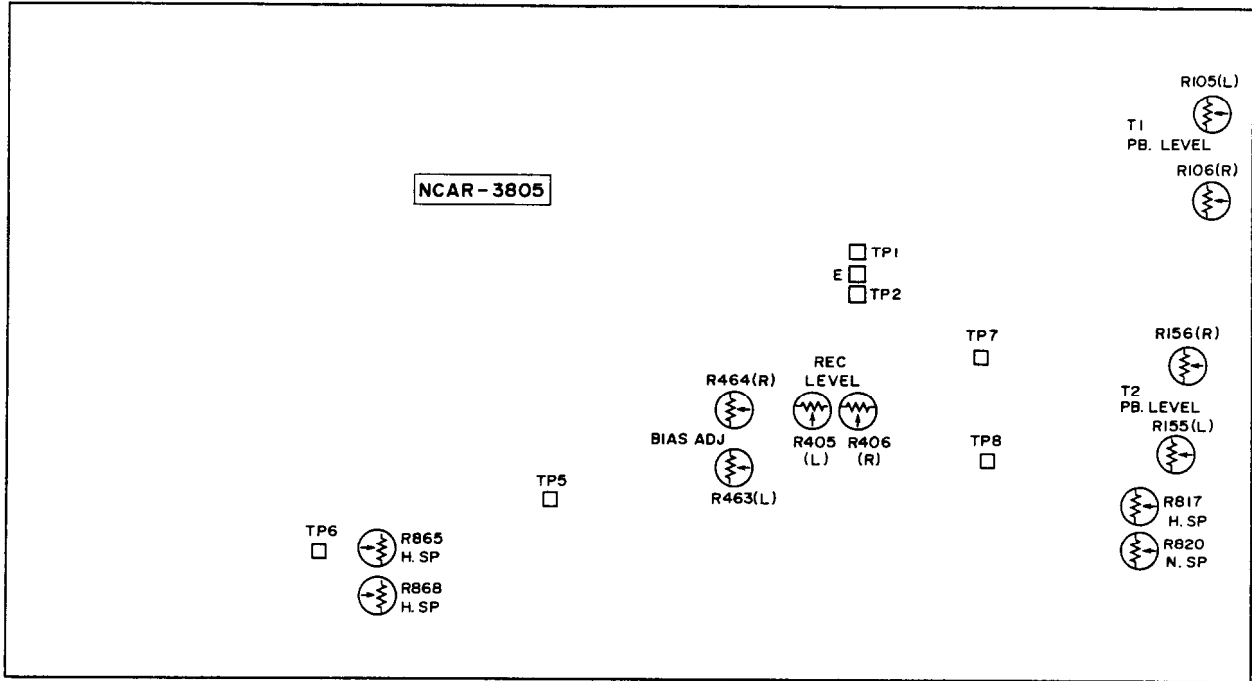

TAPE MECHANISM PARTS LIST

DECK-A

REF.NO.	PARTS NO.	DISCRIPTION
2-1	24602482	IDLER AS
2-2	24601245	REEL MOTOR
2-3	24611382B	BASE AS (CHASSIS)
2-4	24602483	BASE AS (REEL)
2-5	24602484	BASE AS (REEL)
2-7	24609032	PAN HEAD SCREW 2.6×6.4ZN
2-8	24611177	PLASTIC WASHER 1.7×0.25t
2-11	24611175	PLASTIC WASHER 2.1×0.25t
3-3	24611392	HEAD BASE
3-8	24605711	SPRING
3-9	24600066	P/B HEAD
3-10	24600048	E HEAD (DUMMY)
4	24601252	MAIN MOTOR AS
5	24606430	P.C.B. AS (CONTROL)
5-13	24606343	PHOTO REFLECTOR
5-17	24606271	PUSH SWITCH
7	24607102	ARM (EJECT) L
8	24605739	SPRING
12	24607101	ARM (PLAY)
14	24602485	CAM GEAR (3R)
15	24603365	LEVER (REC)
16	24603369	LEVER (PACK)
18	24602489	MAIN BELT
20	24611041	PLASTIC WASHER 2.6×0.25t
23	24610841	PLASTIC WASHER 2.6×0.5t
25	24605714	SPRING
26	24605716	SPRING
29	24602487	FLYWHEEL AS
31	24602414C	PINCH ROLLER AS (R)
36	24609001	PAN HEAD SCREW SW2.6×5ZN
37	24609006A	SCREW
39	8930151	E WASHER 1.5S
40	838130080	WAVE SCREW 3×8ZN
51	24606333	SOLENOID COIL AS
52	24606332A	CORE
53	24606331	PLANGER
61	24611447	PLATE HOLDER AS
62	833126049	TAP-TIGHT SCREW 2.6TTP+4C
63	24611188A	WASHER (OIL SEAL)

DECK-B

REF.NO.	PARTS NO.	DISCRIPTION
2-1	24602482	IDLER AS
2-2	24601245	REEL MOTOR
2-3	24611382B	BASE AS (CHASSIS)
2-4	24602483	BASE AS (REEL)
2-5	24602484	BASE AS (REEL)
2-7	24609032	PAN HEAD SCREW 2.6×6.4ZN
2-8	24611177	PLASTIC WASHER 1.7×0.25t
2-11	24611175	PLASTIC WASHER 2.1×0.25t
3-3	24611392	HEAD BASE
3-8	24605711	SPRING
3-9	24600067	R/P HEAD
3-10	24600032	E HEAD
4	24601252	MAIN MOTOR AS
5	24606428	P.C.B. AS (CONTROL)
5-13	24606343	PHOTO REFLECTOR
5-17	24606271	PUSH SWITCH
7	24607102	ARM (EJECT) L
8	24605739	SPRING
12	24607101	ARM (PLAY)
14	24602485	CAM GEAR (3R)
15	24603365	LEVER (REC)
16	24603366	LEVER (PACK)(L)
17	24603367	LEVER (METAL)(L)
18	24602489	MAIN BELT
20	24611041	PLASTIC WASHER 2.6×0.25t
23	24610841	PLASTIC WASHER 2.6×0.5t
25	24605714	SPRING
26	24605716	SPRING
29	24602487	FLYWHEEL AS
31	24602414C	PINCH ROLLER AS (R)
36	24609001	PAN HEAD SCREW SW2.6×5ZN
37	24609006A	SCREW
39	8930151	E WASHER 1.5S
40	838130080	WAVE SCREW 3×8ZN
51	24606333	SOLENOID COIL AS
52	24606332A	CORE
53	24606331	PLANGER
61	24611449	PLATE HOLDER AS
62	833126049	TAP-TIGHT SCREW 2.6TTP+4C
63	24611188A	WASHER (OIL SEAL)
68	24602404	COUNTER BELTE

A B C D E F G

TAPE MECHANISM-EXPLODED VIEW (DECK-A)

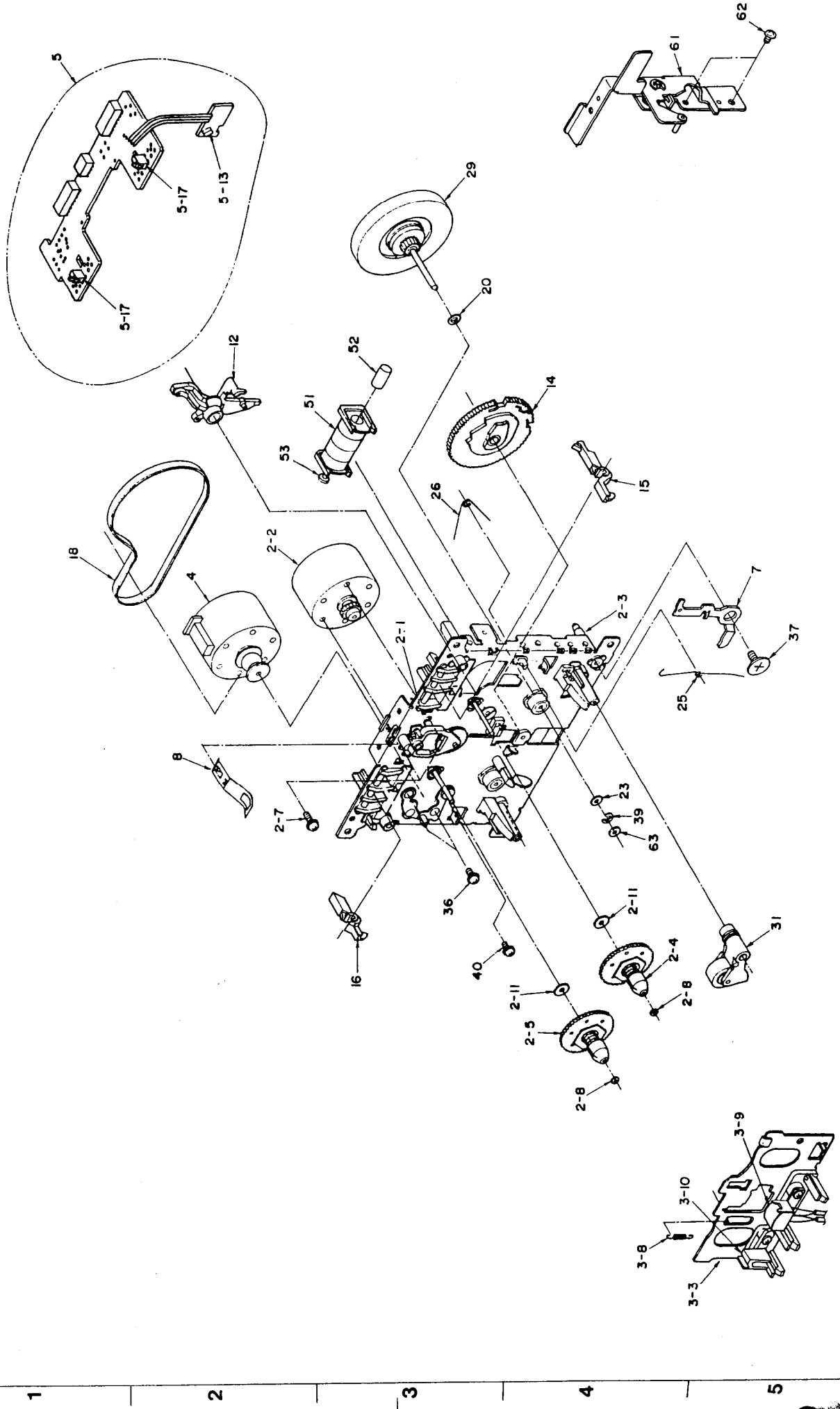

TA-W100 TA-W100

A B C D E F G

TAPE MECHANISM-EXPLODED VIEW (DECK-B)

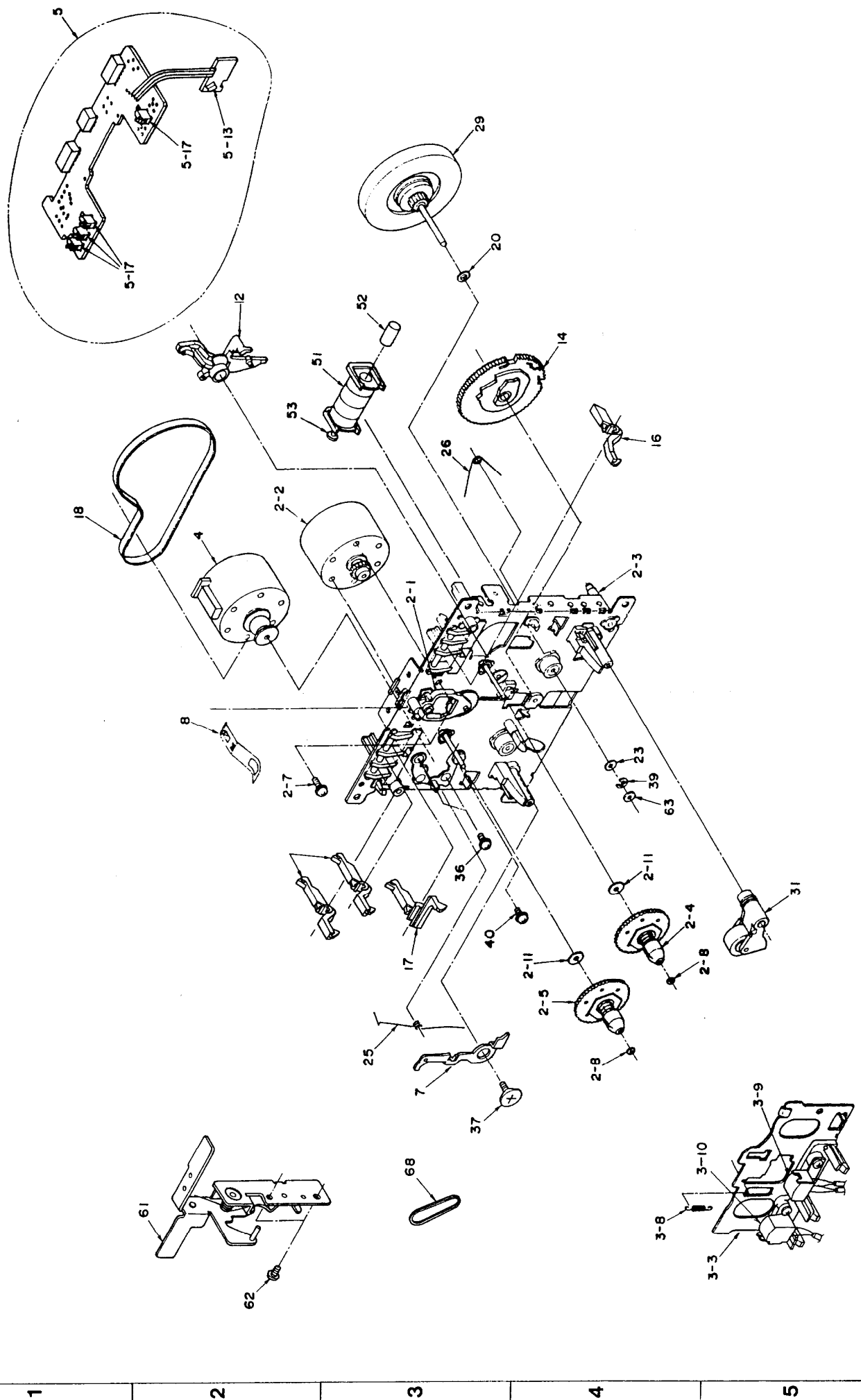

A B C D E F G

SCHEMATIC DIAGRAM (AUDIO SECTION) 1/2

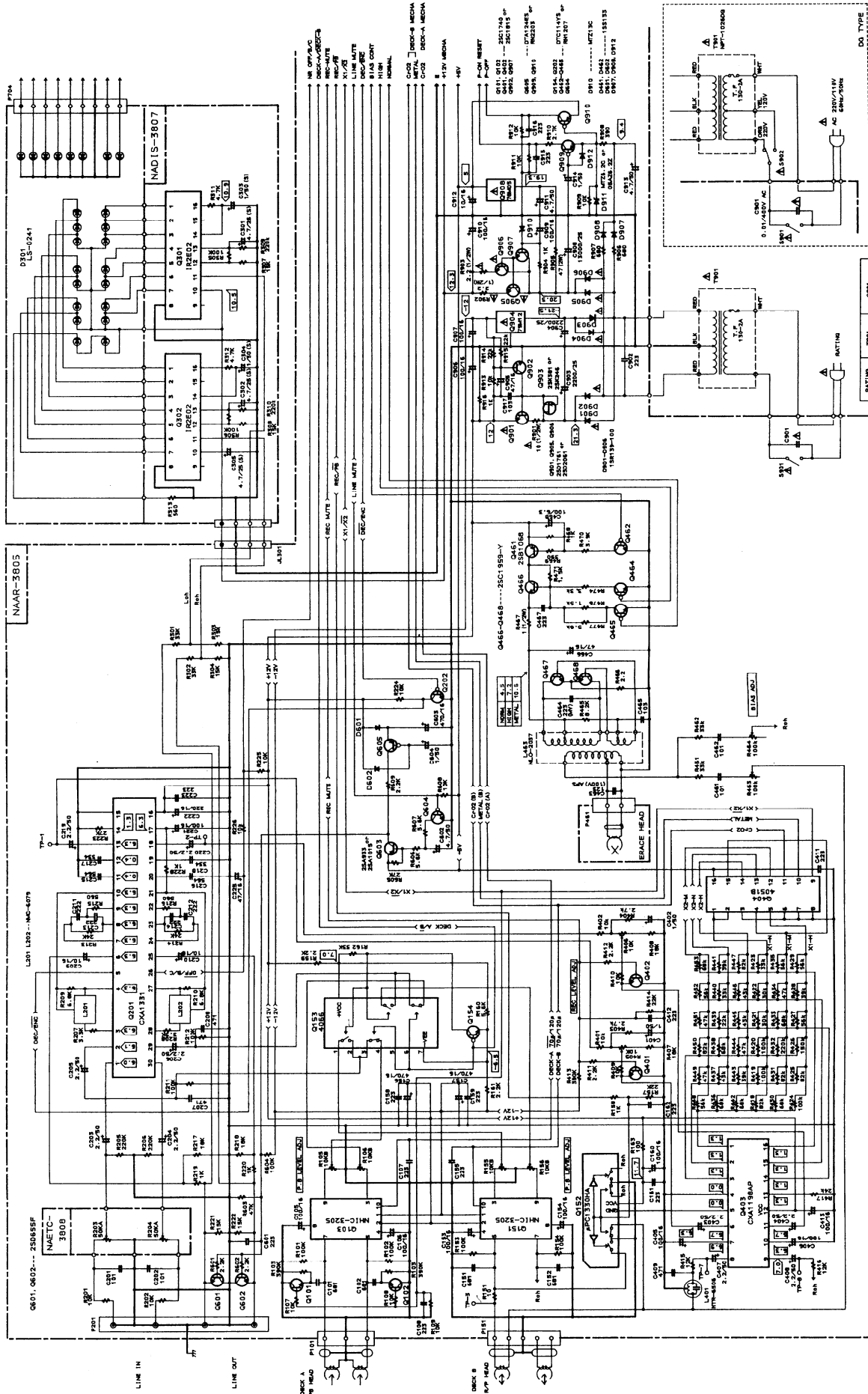

BATTING	TUBE	CR1	DO TYPE
120V/50Hz	6X4-6AR5	0.1/125V AC	
230V/50Hz	6X4-6AR5	0.1/100V AC	
240V/50Hz	6X4-6AR5	0.1/100V AC	

SCHEMATIC DIAGRAM (CONTROL SECTION) 2/2

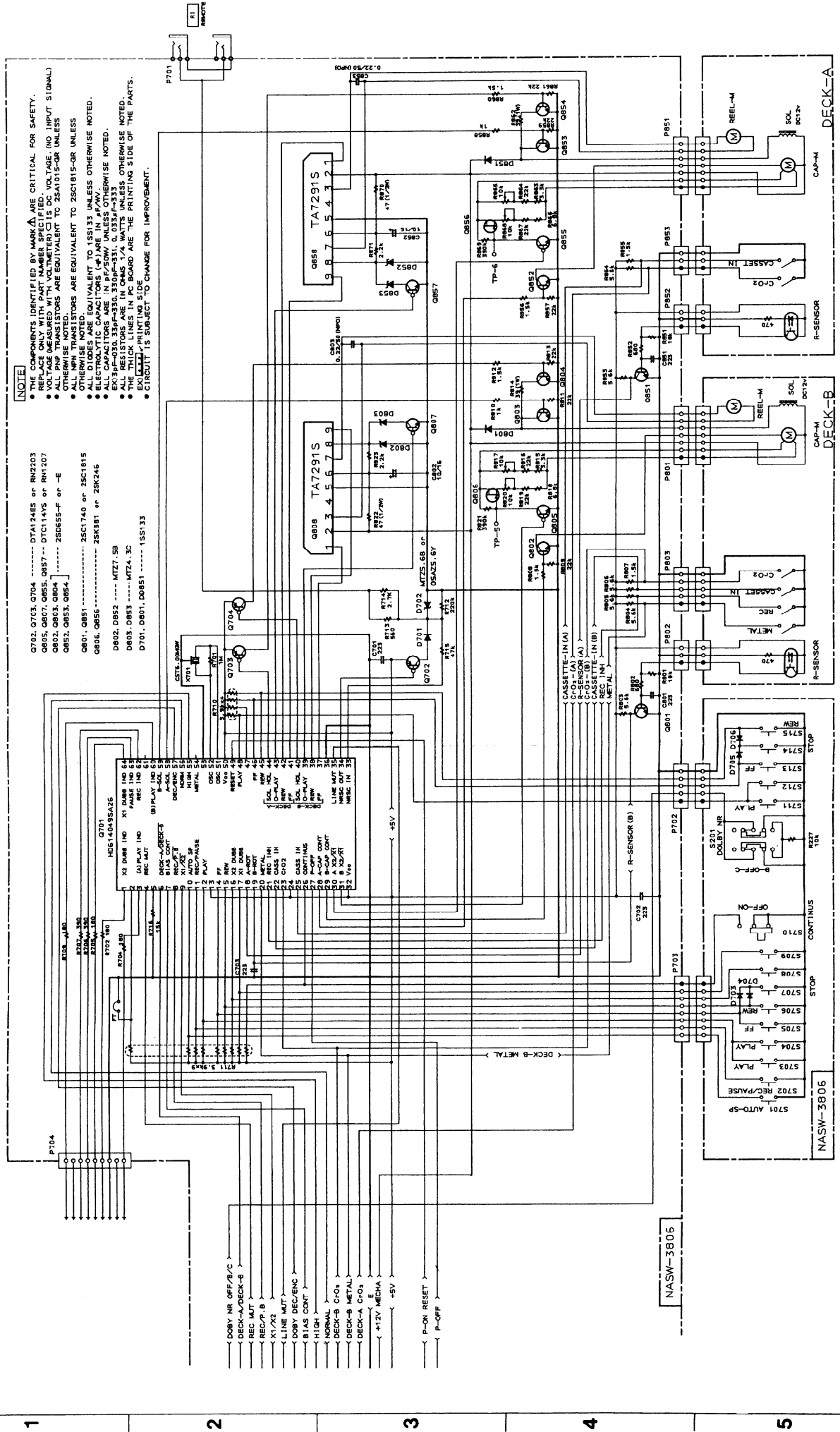

PC BOARD PARTS LIST

NAAR-3805-2

CIRCUIT NO.	PART NO.	DESCRIPTION	CIRCUIT NO.	PART NO.	DESCRIPTION
	ics				
Q103, Q151	222078	NHIC-3205	Q905	2201924,	2SD1761-E,
Q152	22240147	μ PC1330HA		2201925,	2SD1761-F,
Q153	222840661	4066B		2202115 or	2SD2061-E or
Q201	22240316	CXA1331S	Q906	2202116	2SD2061-F
Q351	222652	M5218L		2201924,	2SD1761-E,
Q403	22240267	CXA1198AP		2201925,	2SD1761-F,
Q404	222840511	4051B		2202115 or	2SD2061-E or
Q701	22240317	HD614049SA26	Q907	2202116	2SD2061-F
Q808	22240239	TA-7291S		2211183 or	2SC1740R or
Q858	22240239	TA-7291S		2211255	2SC1815-GR
Q904	222790125	79M12	Q909, Q910	2212600 or	DTA124ES or
Q908	222780055	78M05HF		2213580	RN2203
	Transistors			Diodes	
Q101, Q102	2211183 or	2SC1740R or	D601, D602	223163	1SS133
	2211255	2SC1815-GR	D701	223163	1SS133
Q154	221281 or	DTC114YS or	D702	224450562	MTZ5.6B
	2213570	RN1207	D801	223163	1SS133
Q202	221281 or	DTC114YS or	D802	224450752	MTZ7.5B
	2213570	RN1207	D803	224450433	MTZ4.3C
Q401, Q402	2211183 or	2SC1740R or	D851	223163	1SS133
	2211255	2SC1815-GR	D852	224450752	MTZ7.5B
Q461	2212855 or	2SB1068-U or	D853	224450433	MTZ4.3C
	2212853	2SB1068-K	D901-D906	22380032	1SR139-100
Q462	221281 or	DTC114YS or	D907, D908	223163	1SS133
	2213570	RN1207	D910	224451303	MTZ13C
Q464, Q465	221281 or	DTC114YS or	D911	224450623	MTZ6.2C
	2213570	RN1207	D912	223163	1SS133
Q466-Q468	2211544	2SC1959-Y		Coils	
Q601, Q602	2211705 or	2SD655-E or	L201, L202	233407	NMC-6079
	2211706	2SD655-F	L401, L402	231165	NTR-6506
Q603	2213074 or	2SA933R or	L463	231063	NLO-2037
	2211455	2SA1015-GR	X701	3010149	CST6.00MGW
Q604	221281 or	DTC114YS or		Capacitors	
	2213570	RN1207	C105, C106	391941017	100 μ F16V, ELECT.
Q605	2212600 or	DTA124ES or	C153, C154	391941017	100 μ F16V, ELECT.
	2213580	RN2203	C156, C157	391944717	470 μ F16V, ELECT.
Q702-Q704	2212600 or	DTA124ES or	C160	354741019	100 μ F16V, ELECT.
	2213580	RN2203	C203-C206	391780229	2.2 μ F50V, ELECT.
Q801	2211183 or	2SC1740R or	C209, C210	391741009	10 μ F16V, ELECT.
	2211255	2SC1815-GR	C219, C220	391780229	2.2 μ F50V, ELECT.
Q802-Q804	2211705 or	2SD655-E or	C221	354741019	100 μ F16V, ELECT.
	2211706	2SD655-F	C222	354742219	220 μ F16V, ELECT.
Q805	221281 or	DTC114YS or	C225	354744709	47 μ F16V, ELECT.
	2213570	RN1207	C401, C402	354780109	1 μ F50V, ELECT.
Q806	2212304 or	2SK381-D or	C403, C404	391780229	2.2 μ F50V, ELECT.
	2211945	2SK246-GR	C405, C406	354741019	100 μ F16V, ELECT.
Q807	221281 or	DTC114YS or	C407, C408	391780229	2.2 μ F50V, ELECT.
	2213570	RN1207	C413	354741019	100 μ F16V, ELECT.
Q851	2211183 or	2SC1740R or	C463	370131234	0.012 μ F100V, APS
	2211255	2SC1815-GR	C466	354744709	47 μ F16V, ELECT.
Q852-Q854	2211705 or	2SD655-E or	C468	354721019	100 μ F6.3V, ELECT.
	2211706	2SD655-F	C470	354744709	47 μ F16V, ELECT.
Q855	221281 or	DTC114YS or	C602	354780479	4.7 μ F50V, ELECT.
	2213570	RN1207	C603	354744719	470 μ F16V, ELECT.
Q856	2212304 or	2SK381-D or	C604	354780109	1 μ F50V, ELECT.
	2211945	2SK246-GR	C802	391741009	10 μ F16V, ELECT.
Q857	221281 or	DTC114YS or	C803	352982296	0.22 μ F50V, NP.
	2213570	RN1207	C852	391741009	10 μ F16V, ELECT.
Q901	2201924,	2SD1761-E,	C853	352982296	0.22 μ F50V, NP.
	2201925,	2SD1761-F,	C901	3500065A	0.01 μ F AC400V, IS.
	2202115 or	2SD2061-E or	C903, C904	391952227	2200 μ F25V, ELECT.
	2202116	2SD2061-F	C905	354744709	47 μ F16V, ELECT.
Q902	2211183 or	2SC1740R or	C906, C907	354741019	100 μ F16V, ELECT.
	2211255	2SC1815-GR	C908	3504168	13000 μ F25V, ELECT.
Q903	2212304 or	2SK381-D or	C909, C910	354741019	100 μ F16V, ELECT.
	2211945	2SK246-GR	C911	354780479	4.7 μ F50V, ELECT.

CIRCUIT NO.	PART NO.	DESCRIPTION
C912	391741009	10 μ F16V, ELECT.
C913	354780479	4.7 μ F50V, ELECT.
C914	354780109	1 μ F50V, ELECT.

Resistors

R105, R106	5210217	N06HR10KBD
R155, R156	5210217	N06HR10KBD
R405, R406	5210217	N06HR10KBD
R463, R464	5215047 or 5215024	N08HR100KBC
R467	442520104F	RS1/2WBJ 1 Ω
R710	49163392404	3.9K Ω ×4, 1/10W
R711	49163392409	3.9K Ω ×9, 1/10W
R814	442623904F	RS1WBJ 39 Ω
R817	5210217	N06HR10KBD
R820	5210218	N06HR20KBD
R822	442524704F	RS1/2WBJ 47 Ω
R862	442623904F	RS1WBJ 39 Ω
R865	5210217	N06HR10KBD
R868	5210218	N06HR20KBD
R870	442524704F	RS1/2WBJ 47 Ω
R901	442521004F	RS1/2WBJ 10 Ω
R902, R903	442520224F	RS1/2WBJ 2.2 Ω

Switch

S901	25035558	NPS-111-L520P
------	----------	---------------

Jack

P201	25045165	NPJ-4PD3L59
P701	25045172	HSJ1003-01-020

Plugs

P101	25055133	NPLG-3P117
P151	25055135	NPLG-5P119
P461	25055132	NPLG-2P116

Socket

P851	2000966	NSAS-14P918
P852	2000962	NSAS-6P914
P853	2000972	NSAS-6P924
P801	2000991	NSAS-14P943
P802	2000990	NSAS-6P942
P803	2000989	NSAS-10P941

CIRCUIT NO.	PART NO.	DESCRIPTION
		Miscellaneous
	25060092	NTM-1S33
	27141059	BRACKET
	27150189	SHILD PLATE
	27160211	RAD-68, RADIATOR
	27160211-1	RAD-68B, RADIATOR
	82143006	3P+6FN(BC)
	27301186	CLAMP

NASW-3806-2

CIRCUIT NO.	PART NO.	DESCRIPTION
		Diodes
D703-D706	223163	1SS133
		Switchs
S201	25065297	NSS-23119, SLIDE
S701-S709	25035548	NPS-111-S510, PUSH
S710	25065364	NSS-12138, SLIDE
S711-S715	25035548	NPS-111-S510, PUSH
		Sockets
P701	2009990071	NSAS-16P0108
P702	2000983 or 2000980	NSAS-10P935 or NSAS-10P932

NADIS-3807-2

CIRCUIT NO.	PART NO.	DESCRIPTION
		lc
Q301, Q302	222623	IR2E02
		LED
D301	225253A	LS-0241
		Capacitors
C301, C302	353750479	4.7 μ F25V, ELECT.
C303, C304	353780109	1 μ F50V, ELECT.
C305	353750479	4.7 μ F25V, ELECT.
		Socket
P703	2000984	NSAS-18P936

NAETC-3808-2

CIRCUIT NO.	PART NO.	DESCRIPTION
		Resistor
R203, R204	5104214	N09R2L50KA, VARIABLE

ONKYO CORPORATION

International Division: Onarimon Yusen Bldg., 23-5, Nishi-Shimbashi 3-chome, Minato-ku,
TOKYO 105. JAPAN Tel. 03-432-6981

ONKYO U.S.A CORPORATION

200 Williams Drive, Ramsey, N.J. 07446 Telex: 25-710-988-1033 Tel. 201-825-7950