

ONKYO SERVICE MANUAL

STEREO CASSETTE TAPE DECK MODEL TA-W111

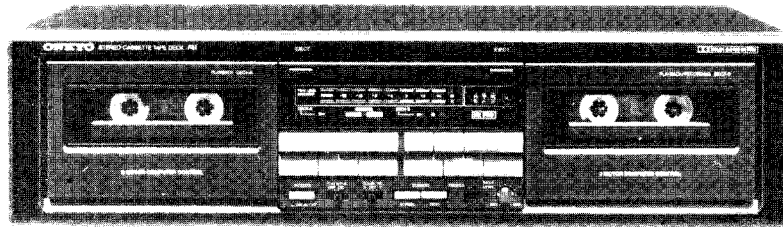

UDN, UDC, UD	120V AC, 60Hz
UP	230V AC, 50Hz
UW	120 or 220V AC, 50/60Hz
UQA	240V AC, 50Hz

SAFETY-RELATED COMPONENT WARNING!!

COMPONENTS IDENTIFIED BY MARK Δ ON THE SCHEMATIC DIAGRAM AND IN THE PARTS LIST ARE CRITICAL FOR RISK OF FIRE AND ELECTRIC SHOCK. REPLACE THESE COMPONENTS WITH ONKYO PARTS WHOSE PARTS NUMBERS APPEAR AS SHOWN IN THIS MANUAL.

MAKE LEAKAGE-CURRENT OR RESISTANCE MEASUREMENTS TO DETERMINE THAT EXPOSED PARTS ARE ACCEPTABLY INSULATED FROM THE SUPPLY CIRCUIT BEFORE RETURNING THE APPLIANCE TO THE CUSTOMER.

SPECIFICATIONS

Track System:	4-tracks, 2-channels
Erasing System:	AC erase
Tape Speed:	4.8 cm/sec. (1-7/8 i.p.s.) 9.6 cm/sec. (3-3/4 i.p.s.) (high speed dubbing)
Wow and Flutter:	0.07% (WRMS)
Frequency Response:	20 - 15,000Hz (Normal) (30 - 14,000Hz \pm 3dB) 20 - 16,000Hz (High) (30 - 15,000Hz \pm 3dB) 20 - 17,000Hz (Metal) (30 - 16,000Hz \pm 3dB)

S/N Ratio:	Dolby NR off: 58dB (metal position tape) A noise reduction of 10dB above 5kHz and 5dB at 1kHz is possible with Dolby B NR. A noise reduction of 20dB at 5kHz is possible with Dolby C NR.
Input Jacks:	Line IN: 2 Input sensitivity: 80mV Input impedance: 50 kohms
Outputs:	Line OUT: 2 Standard output level: 500mV (0dB) Optimum load impedance: over 1 kohms
Motors:	DC servo motor x 2; DC motor x 2
Heads:	REC/PB: 1 PB: 1 ERASE: 1
Power Supply Rating:	U.K. and Australian models: AC 240V, 50Hz U.S.A. and Canadian models: AC 120V, 60Hz Worldwide models: AC 120V and 220V switchable, 50/60Hz
Power Consumption:	33 watts
Dimensions:	455(W) x 120(H) x 306(D)mm (17-15/16" x 4-3/4" x 12-1/16")
Weight:	5.6 kg. (12.3 lbs.)

Specifications and external appearance are subject to change without notice because of product improvements

ONKYO[®]
AUDIO COMPONENTS

BLOCK DIAGRAM

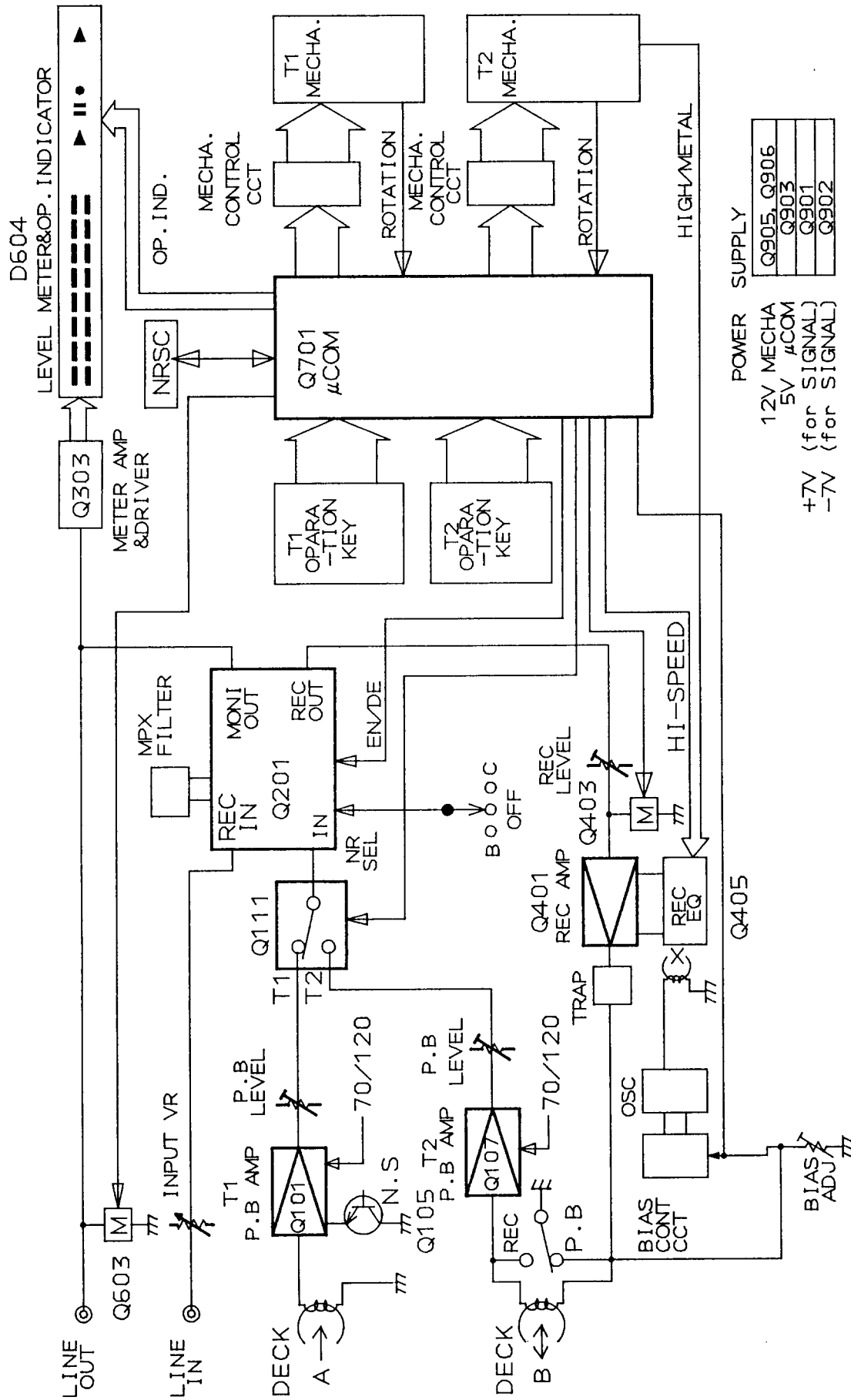

POWER SUPPLY	
Q905, Q906	12V MECHA
Q903	5V μCOM
Q901	+7V (for SIGNAL)
Q902	-7V (for SIGNAL)

IC BLOCK DIAGRAM

HA12142NT (DOLBY NR)

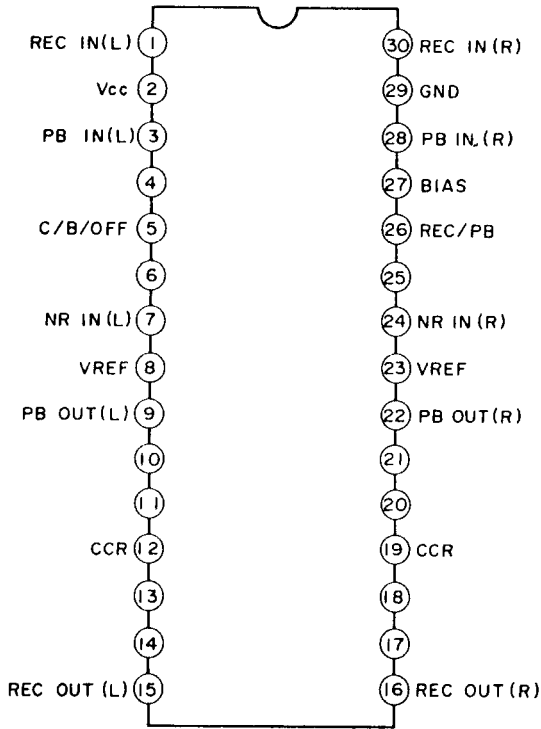

μPC 1330HA (REC/PB SW)

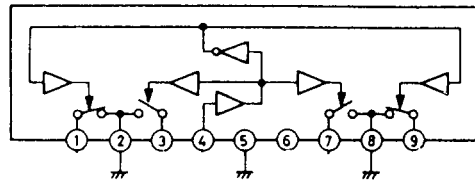

μPC1330HA

Pin No.	Function
1, 9	PB. signal
2	GND
3, 7	REC signal
4	REC/PB SW control
5	GND
6	+B
8	GND

4051B (ANALOG SW)

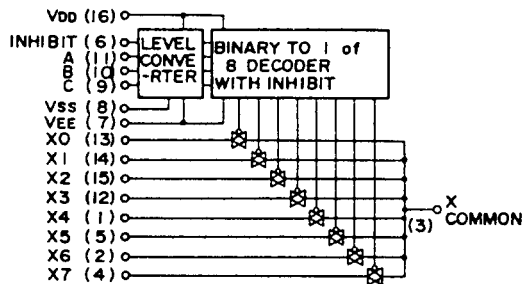

INHIBIT	A (11)	B (10)	C (9)	ON SWITCH
L	L	L	L	X0 (13)
L	H	L	L	X1 (14)
L	L	H	L	X2 (15)
L	H	H	L	X3 (12)
L	L	L	H	X4 (1)
L	H	L	H	X5 (5)
L	L	H	H	X6 (2)
L	H	H	H	X7 (4)
H	X	X	X	NONE

X: Don't Care

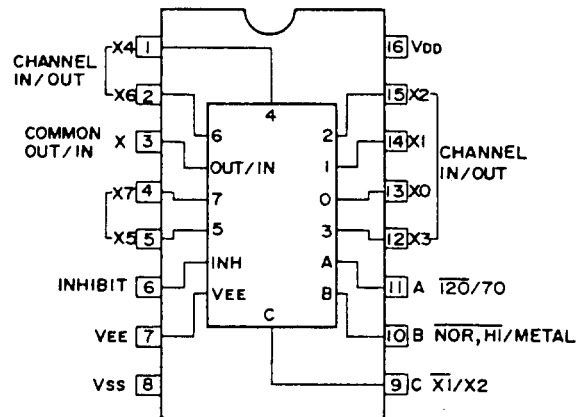

MICRO COMPUTER PORT NAMES AND FUNCTION (HD614049 SA-B05)

No.	Name	IN/OUT	Function
1	X1 DUBBING LED	O	Dubbing indication, H:ON
2	X2 DUBBING LED	O	Dubbing indication, H:ON
3	NC		
4	T1 FWD. LED	O	FWD play indication, H:ON
5	REC. MUTE	O	Recording muting, H:ON
6	INPUT SEL. T2/T1	O	T1/T2 play back signal selection
7	BIAS CONTROL	O	Bias oscillation control, H:ON
8	REC/PB	O	REC/PB selection
9	SPEED X1/X2	O	Tape speed selection
10	T2 AUTO SPACE	I	Auto space operation
11	T2 REC/PAUSE	I	REC/PAUSE operation
12	T2 FF	I	Fast forward operation
13	T2 REW	I	Rewind operation
14	T2 PALY	I	FWD-PLAY operation
15	T2 STOP	I	STOP operation
16	X2 DUBBING	I	Dubbing operation
17	X1 DUBBING	I	Dubbing operation
18	T1 ROTATION-SENSOR	I	Reel rotation sensor
19	T2 ROTATION-SENSOR	I	Reel rotation sensor
20	METAL SW.	I	Record equalizer selection (METAL)
21	T2 REC. INH.	I	Recording prevention
22	T2 CASSETTE IN	I	Cassette loading detection
23	CrO ₂ SW.	I	Record equalizer selection (HIGH)
24	NC		
25	T1 CASSETTE IN	I	Cassette loading detection
26	CONTINUOUS	I	CONTINUOUS OFF/ON
27	P-OFF	I	Power OFF detection
28	T1 CAPSTAN ON/OFF	O	Capstan motor control
29	T2 CAPSTAN ON/OFF	O	Capstan motor control
30	T1 SPEED X2/X1	O	Tape speed control
31	T2 SPEED X2/X1	O	Tape speed control
32	V _{cc}		V _{CC} +5V
33	NRSC IN	I	Remote control signal
34	NRSC OUT	O	Remote control signal
35	LINE MUTE	O	Line muting
36	NOT USED		
37	T2 REEL-FF	O	Reel motor rotation fast forward
38	T2 REEL-REW	O	Reel motor rotation in rewind
39	T2 O-PLAY	O	Reel motor rotation PLAY with "H"
40	T2 SOLENOID	O	Solenoid drive
41	T1 REEL-FF	O	Reel motor rotation fast forward
42	T1 REEL-REW	O	Reel motor rotation in rewind
43	T1 O-PLAY	O	Reel motor rotation PLAY with "H"
44	T1 SOLENOID	O	Solenoid drive
45	T1 STOP	I	STOP operation
46	T1 PALY	I	FWD-PLAY operation
47	T1 REW	I	Rewind operation
48	T1 FF	I	Fast forward operation
49	SYSTEM RESET		System reset for microcomputer
50	TEST		
51, 52	OSC1, OSC2		System clock OSC
53	GND		GND
54	NOT USED		
55	NOT USED		
56	\overline{FT}		
57	DOLBY ENC/DEC	O	Dolby ENC/DEC selector
58	TAPE SEL. METAL	O	Tape selector
59	TAPE SEL. HIGH	O	Tape selector
60	TAPE SEL. NORMAL	O	Tape selector
61	T2 PLAY LED	O	PLAY indication, H:ON
62	NC		
63	T2 REC. LED	O	REC indication, H:ON
64	T2 PAUSE LED	O	PAUSE indication

MICRO COMPUTER (HD614049SA-B05)

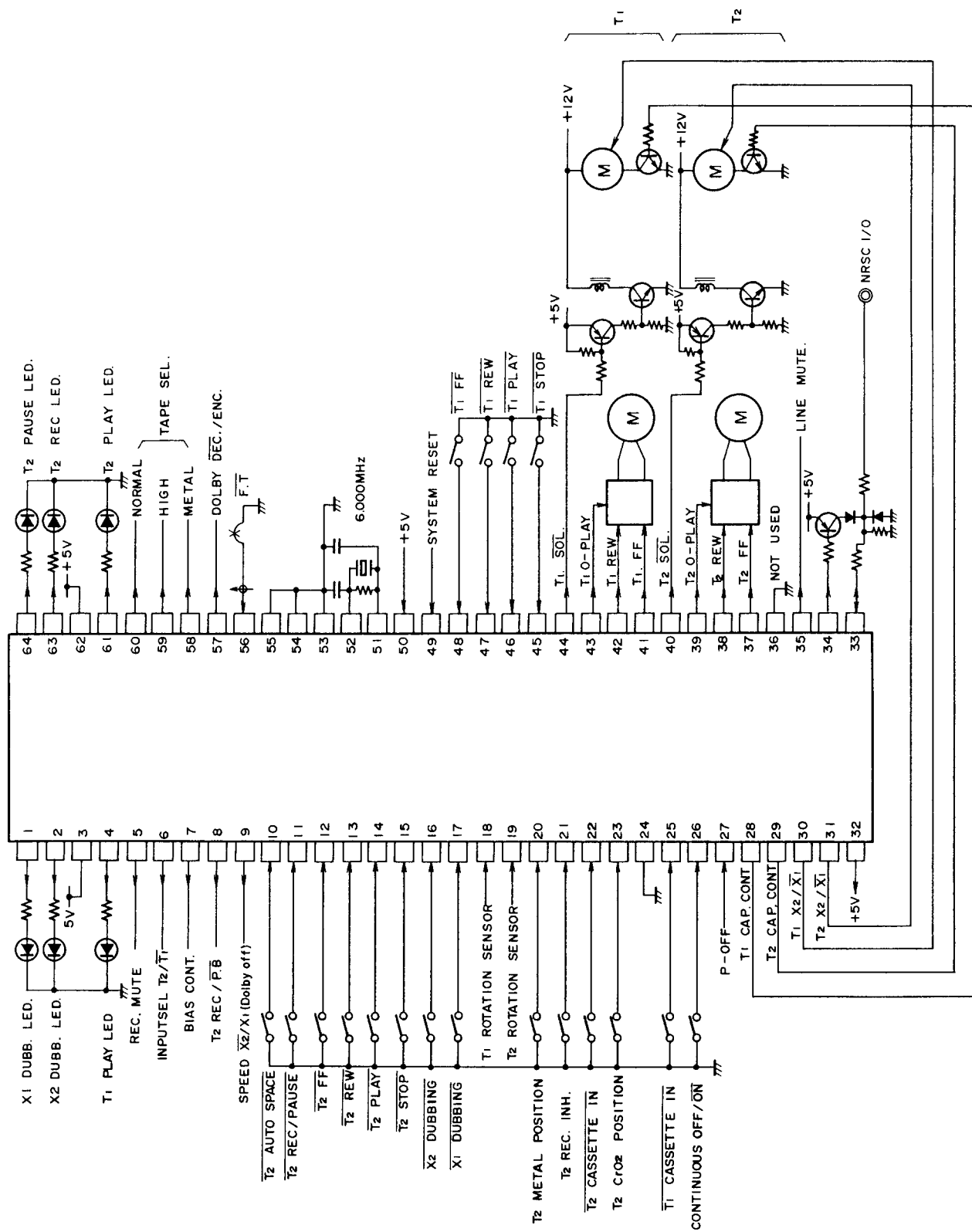

ADJUSTMENT PROCEDURES

PRECAUTIONS

- Before adjustment, clean the following parts with an alcohol moistend swab.
 - * record/playback head
 - * pinch roller
 - * erase head
 - * capstan
- Do not use magnetized screwdriver for adjustments.
- Demagnetize record/playback head with a head demagnetizer.

TEST EQUIPMENT/TOOLS REQUIRED:

- Audio oscillator
- Digital frequency counter
- Oscilloscope
- Attenuator
- AC voltmeter
- Non-magnetic screw driver
- Test tapes
 - TCC-153 : 10 KHz, - 5dB
 - MTT-111 : 3 kHz, - 0dB
 - MTT-150 : Dolby level calibration
400Hz, tone 200nWb/m

Item	Connection of instrument	Line input	Test tape	Mode	Output indicator	Adjustment point	Adjust	Remarks
1	Tape speed Frequency counter to LINE output terminal		MTT-111	PB	Frequency counter	T1 Normal R728 T1 High R731 T2 Normal R747 T2 High R750	3005±5Hz 6010±10Hz 3005±5Hz 6010±10Hz	High speed connect the TP5 (T1) to GND TP-6 (T2) to GND High speed first
2	Head azimuth AC voltmeter and oscilloscope to LINE output terminal		TCC-153	PB	AC voltmeter	Haed azimuth screw	Maximum and same phase at channels L and R	fig-1
3	Play-back level AC voltmeter to terminals TP-3 and TP-4		MTT-150	PB	AC voltmeter	T1 R113 (Ch.L) T1 R114 (Ch.R) T2 R131 (Ch.L) T2 R132 (Ch.R)	300mV	
4	OSC Block Frequency counter to P401 read loose coupling		T2 METAL TAPE MX-C90	T2 REC	Frequency counter	L403	85kHz±2kHz	
5	Bias current fig-2	1kHz, -20dB and 12kHz, -20dB	UD-1 C-90	REC/PB	AC voltmeter	R473 (Ch.L) R474 (Ch.R)	Same level at REC/PB	Input VR maximum.
6	Record level fig-2	1kHz	UD-1 C-90	REC	AC voltmeter	Attenuator or AF OSC output	350mV	
				REC/PB	AC voltmeter	R405 (Ch.L) R406 (Ch.R)	Same level at REC/PB	

Blank tape
 NORMALUD-1 C-90
 HIGH..... XL-II C-90
 METALMX C-90
 PLAY torque.....30~70g/cm
 FF. REW torque.....80~180g/cm
 Back tention 2~7g/cm

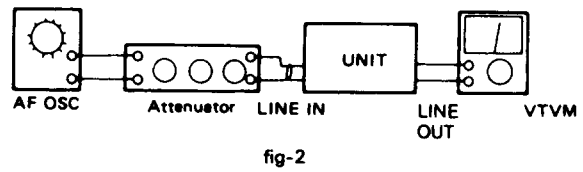
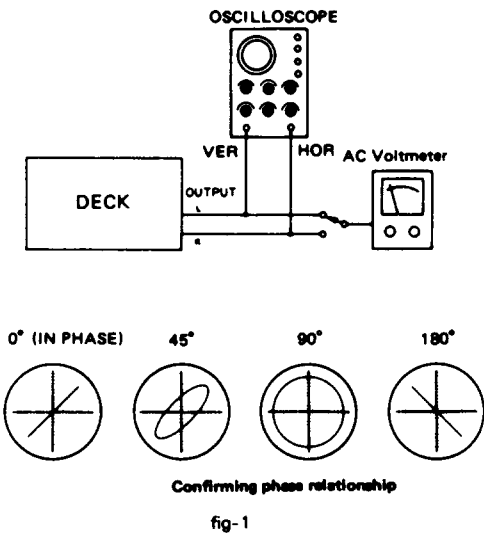
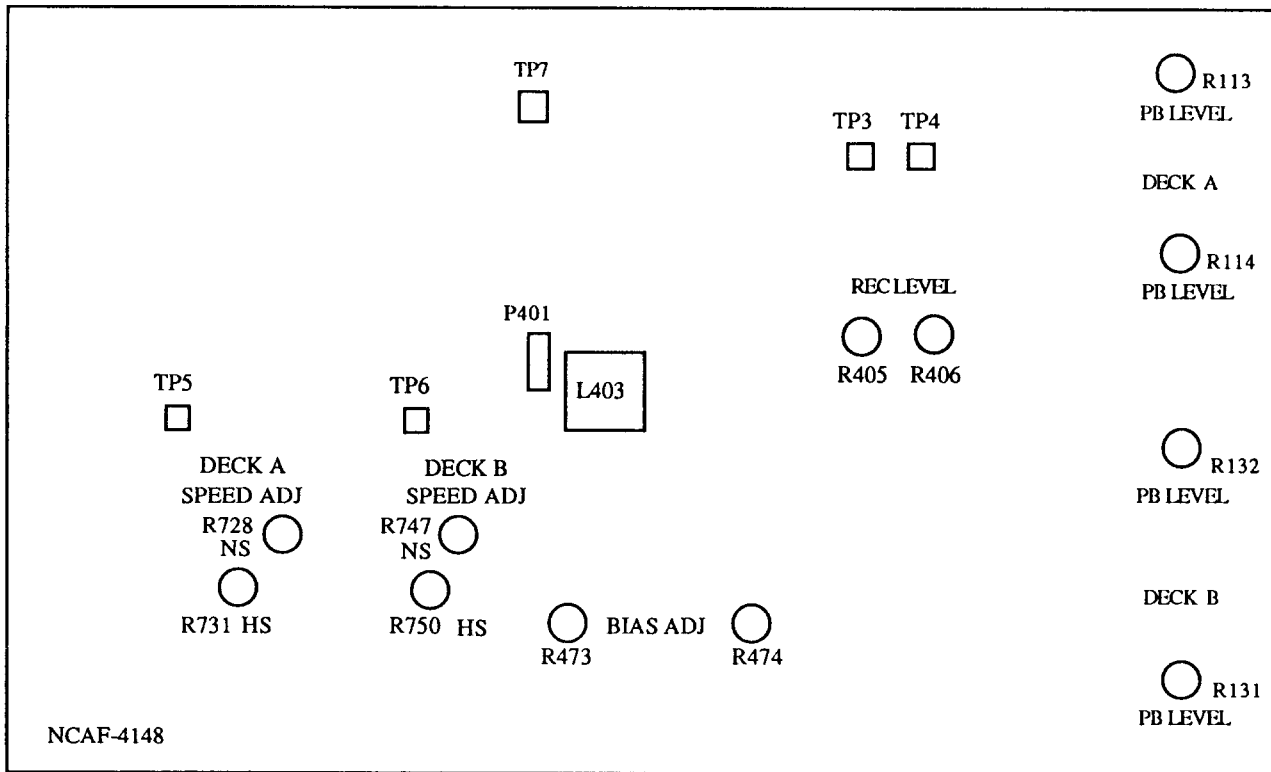

CHASSIS-EXPLODED VIEW

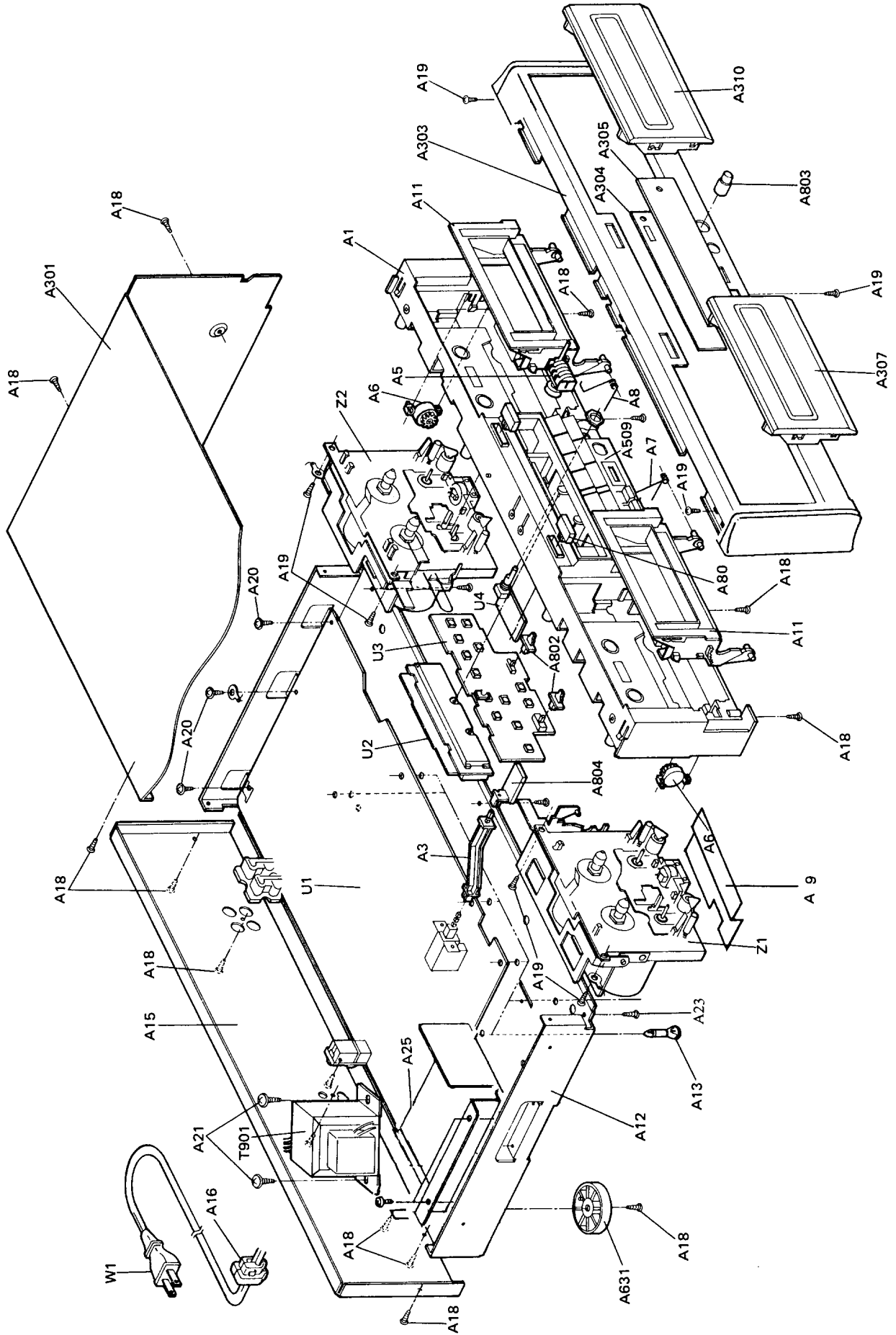

CHASSIS-EXPLODED VIEW PART LIST

REF.NO.	PARTS' NO.	DESCRIPTION	REF. NO.	PART NO.	DESCRIPTION
A1	27110646Y	FRONT BRACKET AS	A802	28324233Y	KNOB (DOL)
A3	27273135A	JOINT (POW)	A803	28324338	KNOB (VOL)
A5	24601220	TAPE COUNTER	A804	28324234Y	KNOB (POW)
A6	28400282	DAMPER	△ S902	25065123	NSS-1258P (W)
A7	27180477A	SPRING (A)	△ T901	23006632	NPT-1100D (D)
A8	27180476A	SPRING (B)	△	23006633	NPT-1100P (P)
A9	27130646DY	BRACKET (F)	△	23006634	NPT-1100DG (W)
A11	28400473-1A	FRAME AS (CASSETTE)	U1	1N109548-7	NAAF-4148-7
-a	28400463B	FRAME (CASSETTE)	U2	1N109549-7	NADIS-4149-7
-b	27180435	SPRING	U3	1N109550-7	NASW-4150-7
-c	28141109	CUSHION	U4	1N109551-7	NAETC-4151-7
A12	27100233	CHASSIS	W1	253112A	AC CORD AS-UC-4 #18 (D)
A13	27190480	HOLDER	△	253164	AC CORD AS-CEE (P/W)
A15	27121546Y	BACK PANEL (D)	△ Z1	244153	CASSETTE DECK MECHANISM NDM-143
	27121546-1Y	BACK PANEL (P)			
	27121546-2Y	BACK PANEL (W)	Z2	244154	CASSETTE DECK MECHANISM NDM-144
A16	27300750	BUSHING (CORD)			
A18	834430088	TAP-TIGHT SCREW 3TTS+8B(BC)			
A19	833430080	TAP-TIGHT SCREW 3TTP+8P(BC)			
A20	831130088	TAP-TIGHT SCREW 3TTW+8B			
A21	830440069	TAP-TIGHT SCREW 4x6			
A23	835430068	TAP-TIGHT SCREW 3TTF+6B(BC)			
A25	27130608D	BRACKET (PT)			
A301	28184479	TOP COVER			
A302	28140837	CUSHION 250x10x91			
A303	1N129701K	FRONT PANEL			
-a	28125226BY	END CAP (L)			
-b	28125227BY	END CAP (R)			
-c	27215205Y	COSMETIC FRAME			
-d	28135199	BADGE			
A304	28133277Y	BACK PLATE			
A305	28191586Y	CLEAR PLATE			
A307	28400710Y	CASSETTE LID AS (A)			
-a	28400711Y	CASSETTE LID (A)			
-b	28400625	WINDOW			
A310	28400710-1Y	CASSETTE LID AS (B)			
-a	28400711-1Y	CASSETTE LID (B)			
-b	28400625	WINDOW			
A509	27215221	COSMETIC FRAME			
A631	27175254	LEG AS			
A801	28324232Y	KNOB (EJ)			

NOTE (D): Only 120V model
(P): Only 230V model
(W): Only worldwide model

**NOTE: THE COMPONENTS IDENTIFIED BY MARK
△ ARE CRITICAL FOR RISK OF FIRE AND
ELECTRIC SHOCK. REPLACE ONLY WITH
PART NUMBER SPECIFIED.**

CIRCUIT NO. PART NO. DESCRIPTION**Resistors**

R113, R114	5210220	N06HR50KBD
R131, R132	5210220	N06HR50KBD
R405, R406	5210064	N06HR 10KBD
R458	442520104F	RS1/2WBJ 1Ω
R459	442523304F	RS1/2WBJ 3.3Ω
R460	442521514F	RS1/2WBJ 150Ω
R461	442522714F	RS1/2WBJ 270Ω
R465, R466	5210070	N06HR100KBD
R724	442524704F	RS1/2WBJ 47Ω
R728	5210218	N06HR20KBD
R731	5210217	N06HR10KBD
R743	442524704F	RS1/2WBJ 47Ω
R747	5210218	N06HR20KBD
R750	5210217	N06HR10KBD
R903	441622704F	RS1/2WBJ 27Ω
R905, R906	442520224F	RS1/2WBJ 2.2Ω

Switch

S901	25035558	NPS-111-L520P
------	----------	---------------

Plug, socket

P101	25055133	NPLG-3P117
P102	25055136	NPLG-6P120
P201	25045329	NPS-4PDBL183
P401	25055132	NPLG-2P-116
P701	25045330	NPJ-2PDBL184
P702A	2000991	NSAS-14P943
P703A	2000992	NSAS-6P944
P704A	2000990	NSAS-6P942
P705A	2000991	NSAS-14P943
P706A	2000992	NSAS-6P944
P707A	2002391010	NSAS-10P0035

Miscellaneous

27160211-1	RAD-68B, RADIATOR
27160211	RAD-68, RADIATOR
27141059	BRACKET
25050092	NTM-1S33, TERMINAL
82143006	3P+6FN(BC)

NADIS-4149-7**CIRCUIT NO. PART NO. DESCRIPTION**

IC		
Q303, Q304	222623	IR2E02
LED		
D604	225253	LS-0241
Capacitors		
C301, C302	353750479S	4.7μF25V, ELECT.
C303, C304	353780109S	1μF50V, ELECT.
C305	353750479S	4.7μF25V, ELECT.
Socket		
P708A	2000985A or 200098A	NSAS-18P937 or NSAS-18P934

NASW-4150-7**CIRCUIT NO. PART NO. DESCRIPTION**

Switch		
S201	25065297	NSS-23119
S701-S704	25035548	NPS-111-S510
S706	25065364	NSS-12138
S707-S710	25035548	NPS-111S510
S712-S715	25035548	NPS-111S510

NAETC-4151-7**CIRCUIT NO. PART NO. DESCRIPTION**

Resistors		
R203, R204	5104214	N09R2L50KA15F

IC BLOCK DIAGRAM

IR-2E02 (LEVEL METER DRIVE)

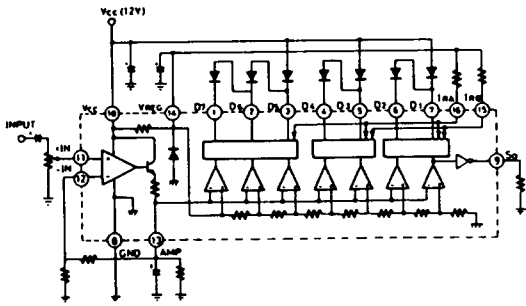

4066B (ANALOG SW)

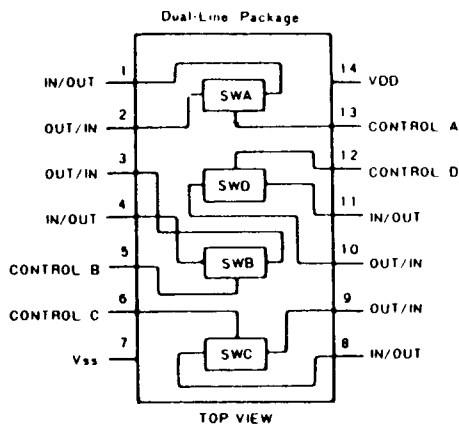

CXA1198A (REC EQ)

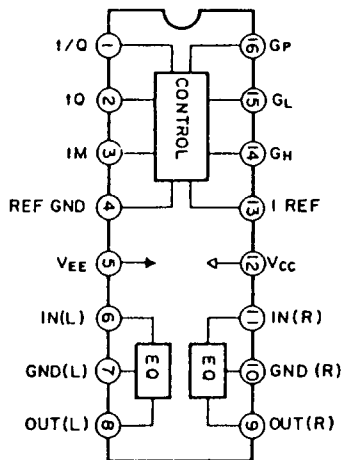

TA7291S (MOTOR DRIVE)

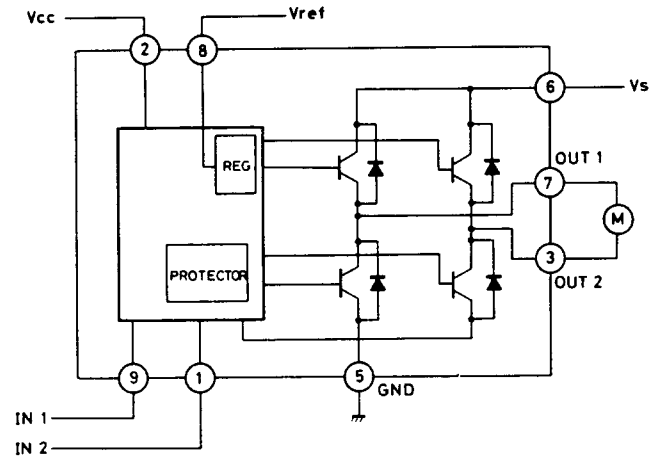

INPUT		OUTPUT		MODE
IN 1	IN 2	OUT 1	OUT 2	
0	0	∞	∞	STOP
1	0	H	L	CW/CCW
0	1	L	H	CCW/CW
1	1	L	L	BRAKE

LS0241 (DISPLAY TUBE)

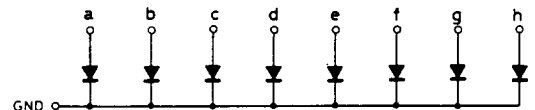
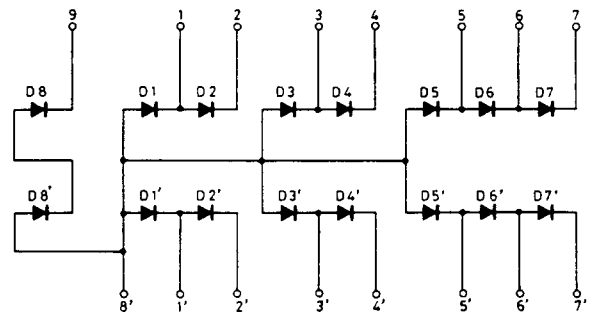
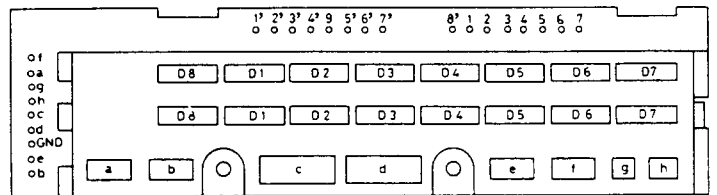

D1 ~ D4, D8, D1' ~ D4' D8; a, b, e, f, --- GRN
 D5 ~ D7, D5' ~ D7'; c, d, g, h ----- RED

TAPE MECHANISM PARTS LIST (DECK-B)

REF.NO.	PART NO.	DESCRIPTION
2-1	24602482	IDLER AS
2-2	24601245	REEL MOTOR
2-3	24611382B	BASE AS (CHASSIS)
2-4	24602483	BASE AS (REEL)
2-5	24602484	BASE AS (REEL)
2-7	24609032	PAN HEAD SCREW 2.6×6.4ZN
2-8	24611177	PLASTIC WASHER 1.7×0.25t
2-11	24611175	PLASTIC WASHER 2.1×0.25t
3-3	24611501	HEAD BASE
3-8	24605711	SPRING
3-9	24600067	R/P HEAD
3-10	24600032	E HEAD
3-11	24606472	LEAD WIRE (R/P)
3-12	24606473	LEAD WIRE (E)
4	24601252	MAIN MOTOR AS
5	24606428	P.C.B. AS (CONTROL)
5-13	24606463	PHOTO REFLECTOR
5-17	24606271	PUSH SWITCH
7	24607102	ARM (EJECT) L
8	24605739	SPRING
12	24607116	ARM (PLAY)
14	24602485A	CAM GEAR (3R)
15	24603365A	LEVER (REC)
16	24603366	LEVER (PACK) (L)
17	24603367	LEVER (METAL) (L)
18	24602539	MAIN BELT
20	24611041	PLASTIC WASHER 2.6×0.25t
23	24610841	PLASTIC WASHER 2.6×0.55t
25	24605741	SPRING
26	24605716	SPRING
29	24602487	FLYWHEEL AS
31	24602541	PINCH ROLLER AS (R)
36	24609001	PAN HEAD SCREW SW2.6×5ZN
37	24609006A	SCREW
39	8930151	E WASHER 1.5S
40	838130080	WAVE SCREW 3×8ZN
43	24611488	CUSHION (HOLDER)
51	24606333	SOLENOID COIL AS
52	24606332A	CORE
53	24606331	PLANGER
61	24611449	PLATE HOLDER AS
62	833126049	TAP-TIGHT SCREW 2.6TTP+4C
63	24611188A	WASHER (OIL SEAL)
68	24602404	COUNTER BELTE

TAPE MECHANISM PARTS LIST (DECK-A)

REF.NO.	PART NO.	DESCRIPTION
2-1	24602482	IDLER AS
2-2	24601245	REEL MOTOR
2-3	24611382B	BASE AS (CHASSIS)
2-4	24602483	BASE AS (REEL)
2-5	24602484	BASE AS (REEL)
2-7	24609032	PAN HEAD SCREW 2.6×6.4ZN
2-8	24611177	PLASTIC WASHER 1.7×0.25t
2-11	24611175	PLASTIC WASHER 2.1×0.25t
3-3	24611501	HEAD BASE
3-8	24605711	SPRING
3-9	24600066	P HEAD
3-10	24600048	E HEAD (DUMMY)
3-12	24606474	LEAD WIRE (R/P)
4	24601252	MAIN MOTOR AS
5	24606430	P.C.B. AS (CONTROL)
5-13	24606463	PHOTO REFLECTOR
5-17	24606271	PUSH SWITCH
7	24607065B	ARM (EJECT) L
8	24605739	SPRING
12	24607116	ARM (PLAY)
14	24602485A	CAM GEAR (3R)
15	24603365A	LEVER (REC)
16	24603369	LEVER (PACK)
18	24602539	MAIN BELT
20	24611041	PLASTIC WASHER 2.6×0.25t
23	24610841	PLASTIC WASHER 2.6×0.55t
25	24605762	SPRING
26	24605716	SPRING
29	24602487	FLYWHEEL AS
31	24602541	PINCH ROLLER AS (R)
36	24609001	PAN HEAD SCREW SW2.6×5ZN
37	24609006A	SCREW
39	8930151	E WASHER 1.5S
40	838130080	WAVE SCREW 3×8ZN
43	24611488	CUSHION (HOLDER)
51	24606333	SOLENOID COIL AS
52	24606332A	CORE
53	24606331	PLANGER
61	24611447	PLATE HOLDER AS
62	833126049	TAP-TIGHT SCREW 2.6TTP+4C
63	24611188A	WASHER (OIL SEAL)

TAPE MECHANISM-EXPLODED VIEW (DECK-A)

A B C D E F G

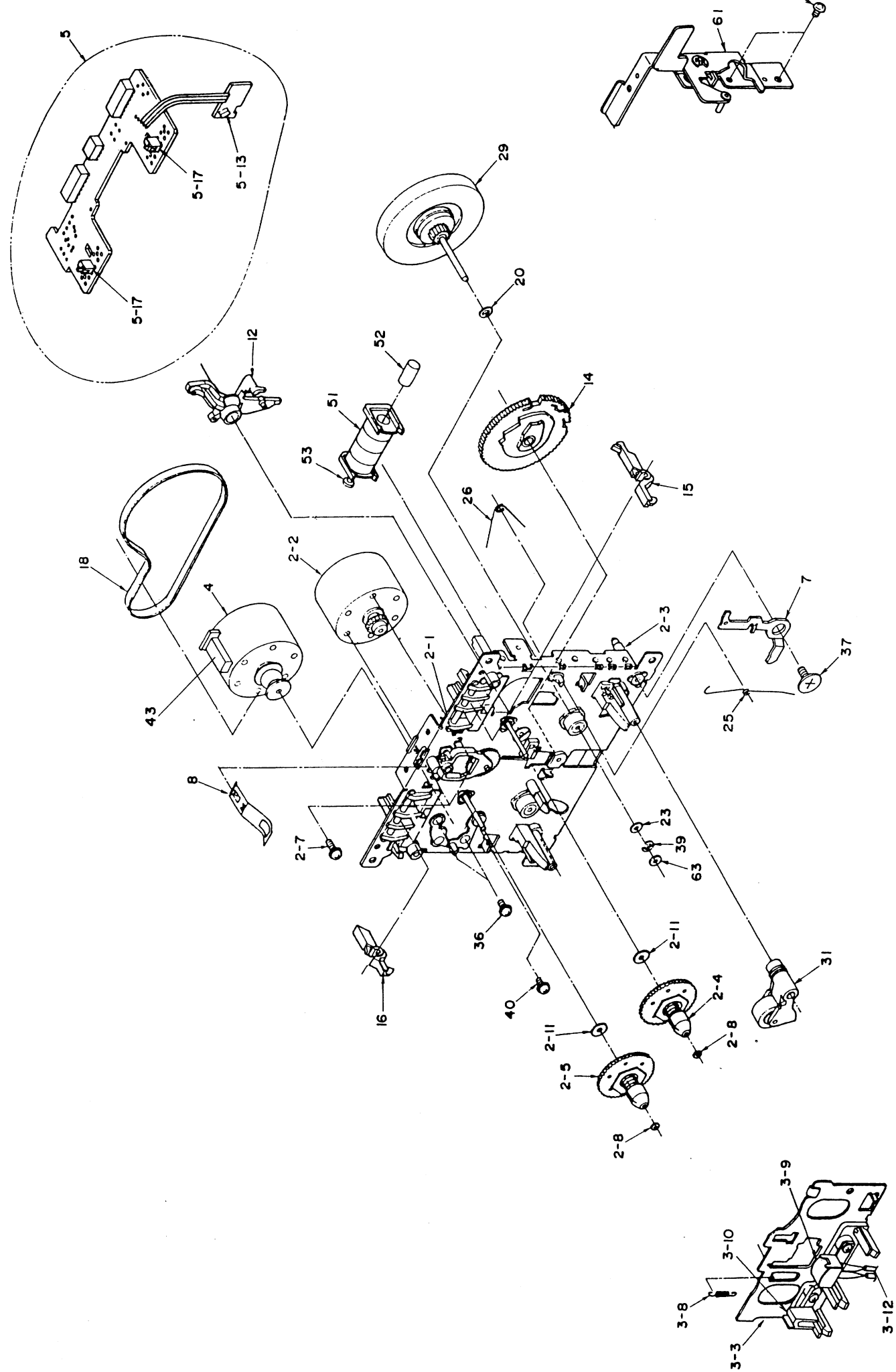

TYPE MECHANISM-EXPLODED VIEW (DECK-B)

A B C D E F G

1A-W111 1A-W111

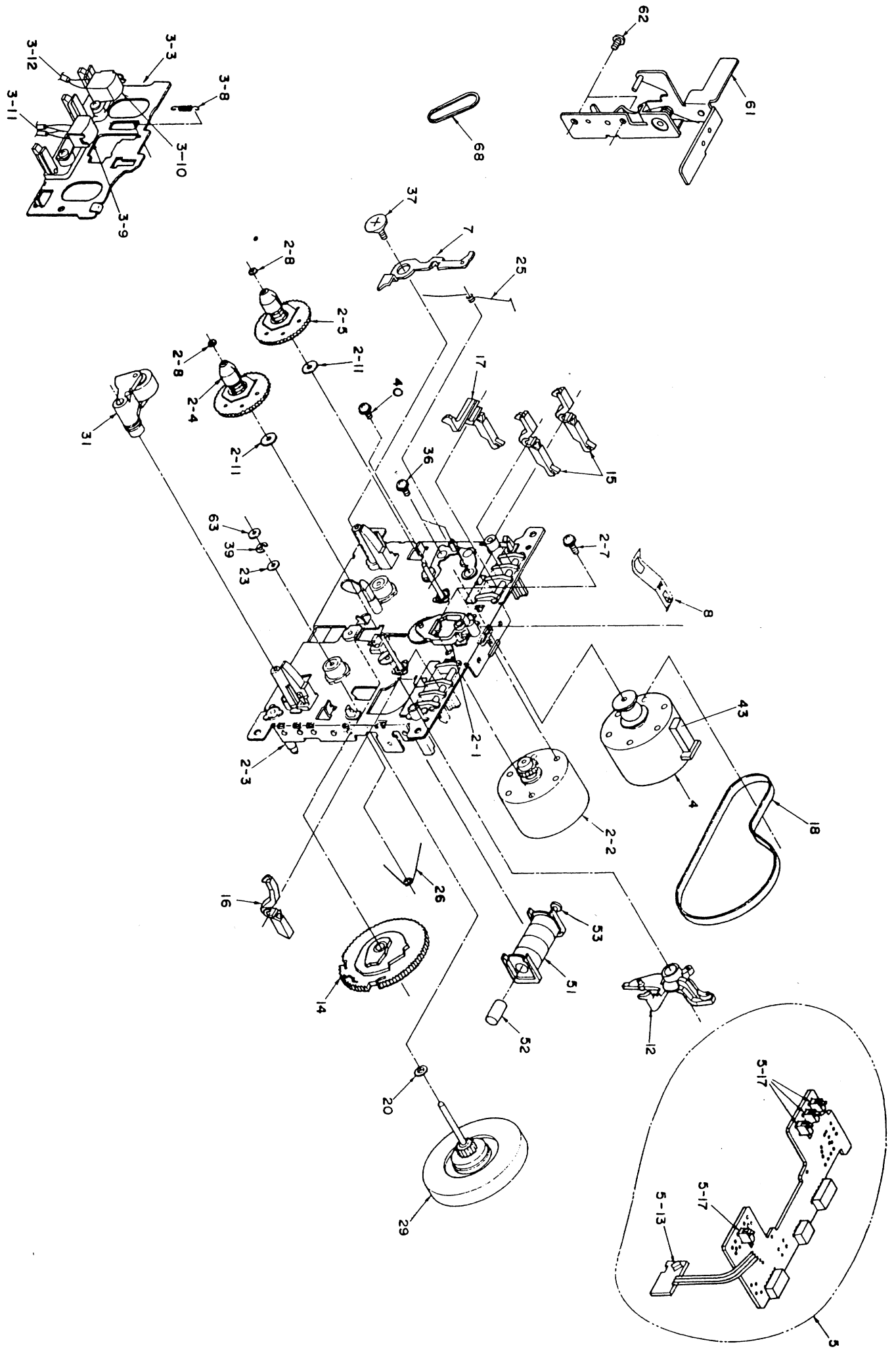

SCHEMATIC DIAGRAM (AUDIO SECTION) 1/2

A

B

C

D

E

F

G

1A-W111

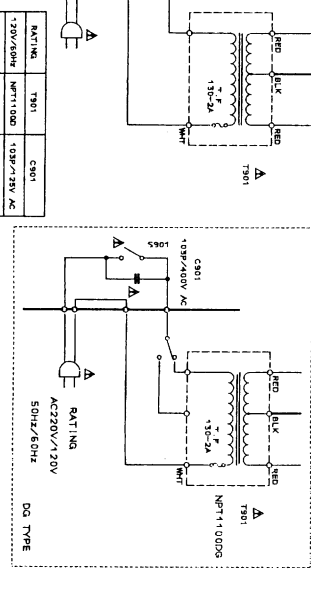
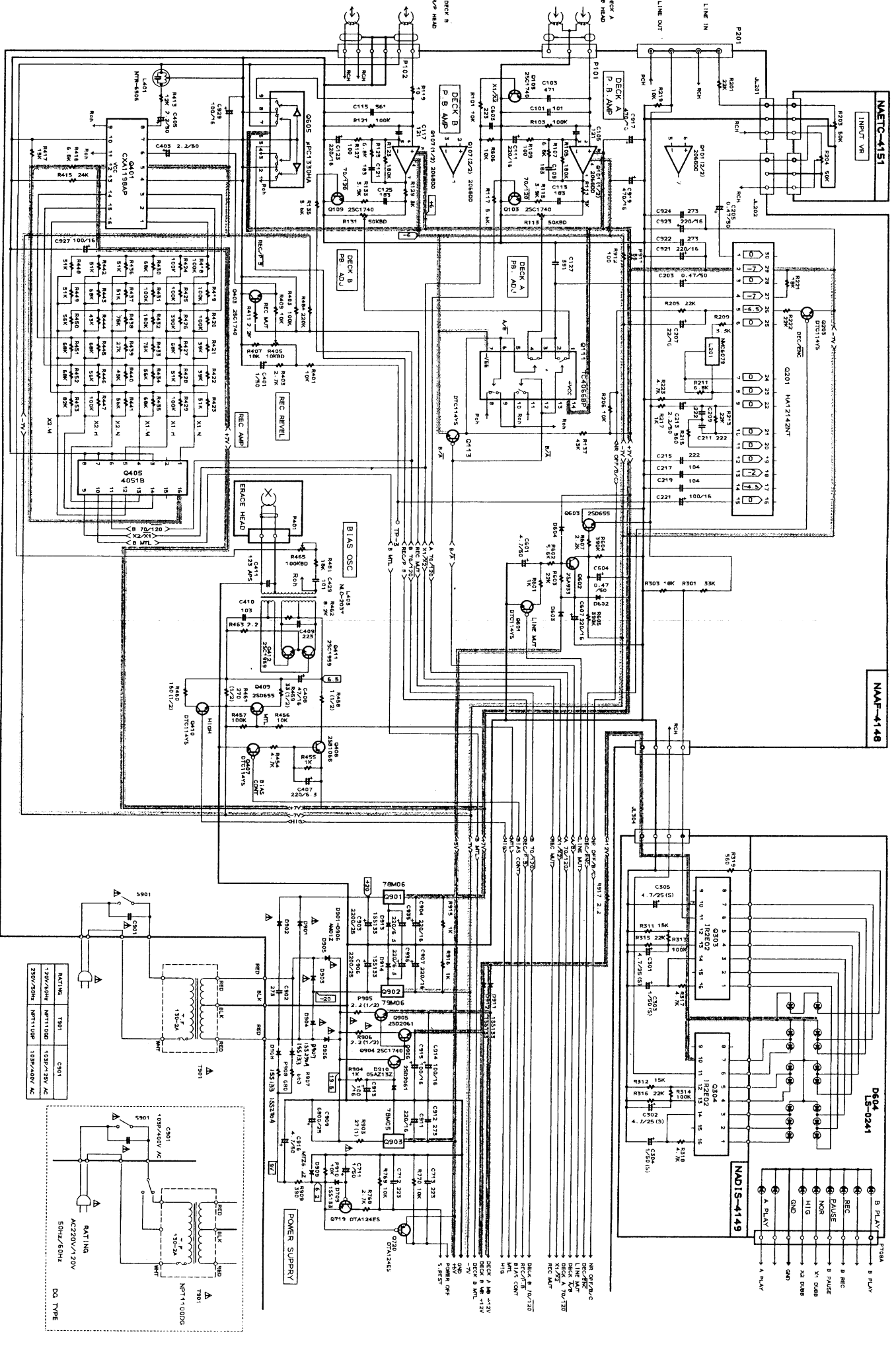

ONKYO CORPORATION

A

B

C

D

E

F

G

SCHEMATIC DIAGRAM (CONTROL SECTION) 2/2

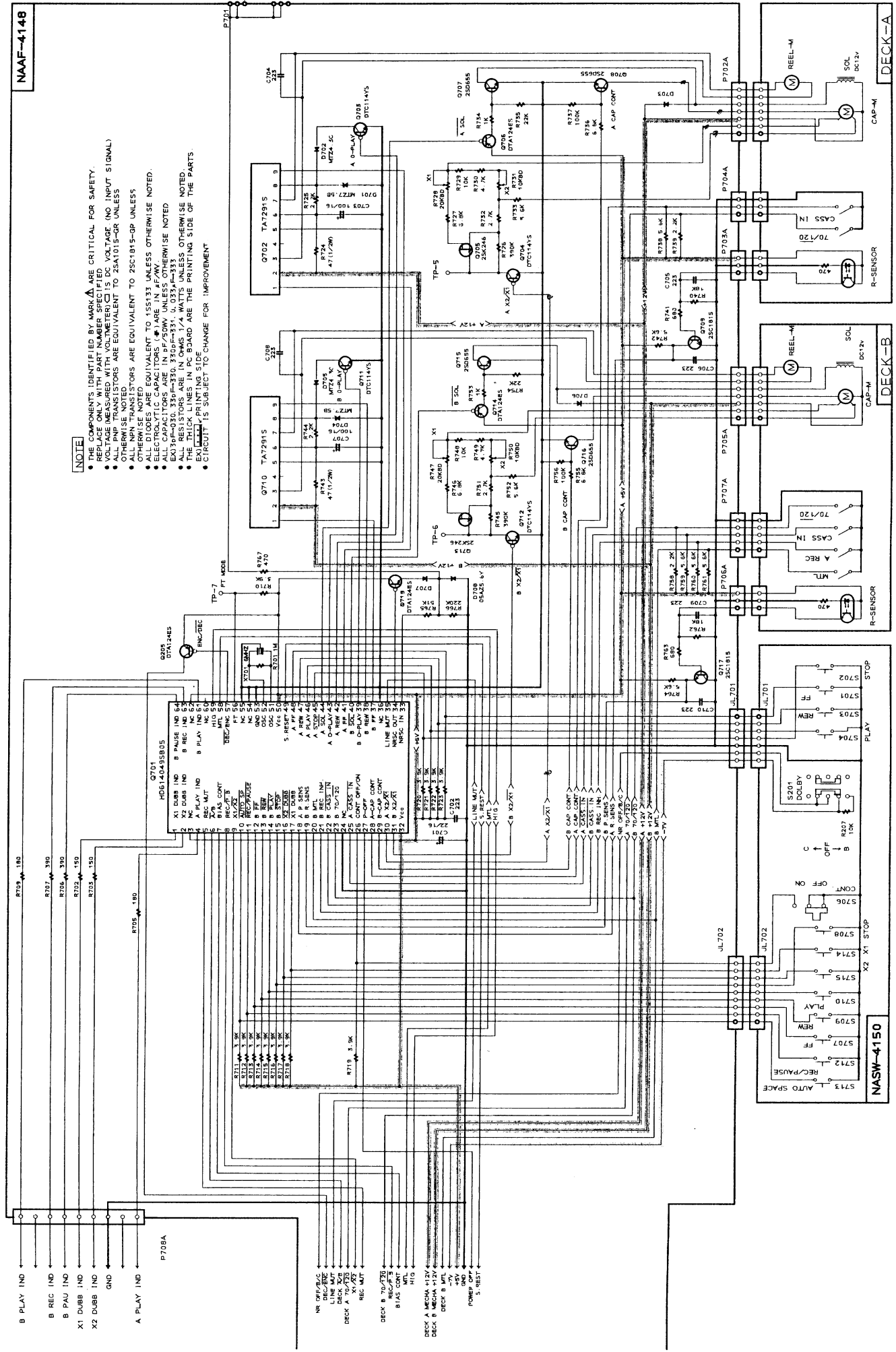

NASW-4150

DECK-B

DECK-A

PACKING VIEW

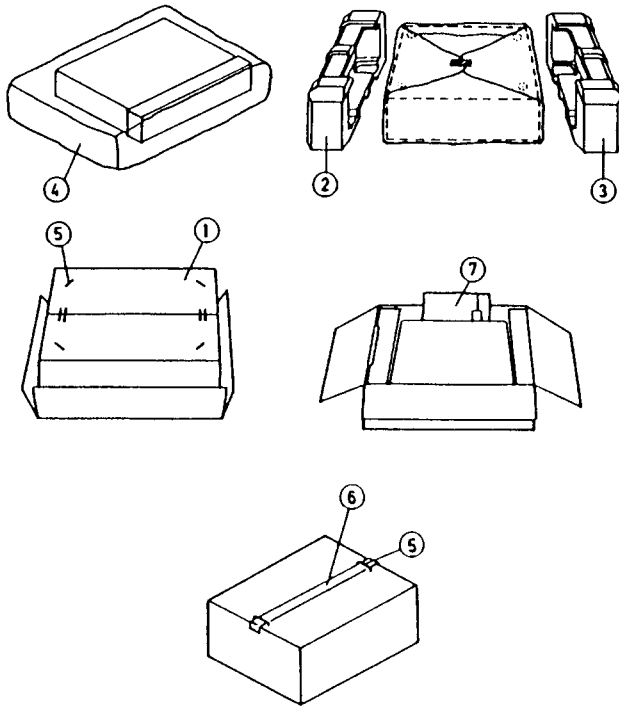

PACKING PART LIST

REF.NO.	PART NO.	DESCRIPTION
1	29052344AY	Master carton box
2	29091452B	Pad (L)
3	29091453B	Pad (R)
4	29100105	620×550 Poly bag
5	282301	Sealing hook
6	29110071	Damplon tape
7		
	Accessory bag ass'y	
	29341690	Instruction manual (D)
	29341717Y	Instruction manual (G/W/C)
	2010098A	Connection cable
	29100006A	350×250 Poly bag
	29365019A	Warranty card (N)
	25055040	CV plug CV-K-2 (W)
	29358002J	Service station list (N)

NOTE (D): Only 120V model
 (N): Only U.S.A. model
 (W): Only worldwide model
 (C): Only Canadian model

ONKYO CORPORATION

International Division: Onarimon Yusen Bldg., 23-5, Nishi-Shimbashi 3-chome, Minato-ku,
 TOKYO 105, JAPAN Tel: 03-3432-6987 Fax: 03-3436-6979

ONKYO U.S.A. CORPORATION

200 Williams Drive, Ramsey, N.J. 07446, U.S.A.
 Tel: 201-825-7950 Fax: 201-825-8150

ONKYO Europe GmbH

Hellersbergstrasse 4, W-4040 Neuss GERMANY
 Tel: 02101 12 00 75 Fax: 02101 10 33 06 TLX: 85 17 916 ONDU D

ONKYO FRANCE S.A.R.L.

Immeuble Le DIAMANT, Domaine Technologique De Saclay, 4 rue Rene Razel,
 91892 SACLAY, FRANCE Tel: (1)69 41 35 10 Fax: (1)69 41 35 84