

ONKYO® SERVICE MANUAL

PCS-D1

CASSETTE /CD PLAYER

TU-D1

Black and Silver models

UDN, UDC, UD	120V AC, 60Hz
UP	230V AC, 50Hz
UW	120 / 220V AC, 50 / 60Hz
UQA	240V AC, 50Hz

SAFETY-RELATED COMPONENT WARNING!!

COMPONENTS IDENTIFIED BY MARK Δ ON THE SCHEMATIC DIAGRAM AND IN THE PARTS LIST ARE CRITICAL FOR RISK OF FIRE AND ELECTRIC SHOCK. REPLACE THESE COMPONENTS WITH ONKYO PARTS WHOSE PARTS NUMBERS APPEAR AS SHOWN IN THIS MANUAL.

MAKE LEAKAGE-CURRENT OR RESISTANCE MEASUREMENTS TO DETERMINE THAT EXPOSED PARTS ARE ACCEPTABLY INSULATED FROM THE SUPPLY CIRCUIT BEFORE RETURNING THE APPLIANCE TO THE CUSTOMER.

SPECIFICATIONS

CD Player Section

Signal readout system:	Optional non-contact
Reading rotation:	About 500 ~ 200 r.p.m. (constant linear velocity)
Linear velocity:	1.2 ~ 1.4 m/s
Error correction system:	Cross Interleave Reed-Solomon code
D/A converter:	1 BIT D/A Converter

Sampling frequency:	176.4kHz (4 times oversampling)
Number of channels:	2 (stereo)
Frequency response:	20 Hz ~ 20 kHz
Total harmonic distortion:	0.03% (at 1 kHz)
Dynamic range:	75dB
Signal to noise ratio:	90dB
Channel separation:	70dB (at 1 kHz)
Wow and Flutter:	Below threshold of measurability

Cassette Player Section

Track System:	4-tracks, 2-channels
Erasing System:	AC erase
Tape Speed:	4.8 cm/sec. (1-7/8 i.p.s.)
Wow and Flutter:	0.07% (WRMS) 0.15% W PEAK
Frequency Response:	20 ~ 15,000Hz (Normal) (30 ~ 14,000Hz \pm 3dB) 20 ~ 16,000Hz (High) (30 ~ 15,000Hz \pm 3dB) 20 ~ 17,000Hz (Metal) (30 ~ 16,000Hz \pm 3dB)
S/N Ratio:	Dolby NR off: 58dB (metal position tape) A noise reduction of 10dB above 5kHz and 5dB at 1kHz is possible with Dolby B NR. A noise reduction of 20dB at 5kHz is possible with Dolby C NR.



ONKYO
AUDIO COMPONENTS

Input Jacks: AUX IN: 2
 Input sensitivity: 280/500mV
 Input impedance: 50 kohms

Outputs: Monitor Jack: 1
 Optimum load impedance:
 8-200Ohms

Motors: DC servo motor × 1; DC motor × 1

Heads: REC/PB: 1
 ERASE: 1

Power Supply Rating: (AC Adaptor)
 European models: AC 230V, 50Hz
 3 pin Attachment plug
 U.S.A. and Canadian models:
 AC 120V, 60Hz
 3 pin Attachment plug

U.K. and Australian models:
 AC 240V, 50Hz
 3 pin Attachment plug

Worldwide models: AC 120V ~ 220V variable,
 50/60Hz 3 pin Attachment plug

Battery Pack (BT-D1)...Option
 Used Battery Small sealed lead battery
 Normal voltage 6V DC) Requires 2
 Nominal capacity 1800 mA) battery packs

Dimensions: 295 (W) × 80 (H) × 256 (D) mm
 (11-5/8" × 3-1/8" × 10-1/8")

Weight: 2.6kg. (5.7lbs.)

Design and specifications are subject to change without prior notice.

SERVICE GUIDE

RESET AND POWER CIRCUIT

By connecting AC Adapter, Q917OUT is to set at 5V resetting Main Microcomputer Q804 and Key Microcomputer Q806 by Q918. Q804 "44 is to set at "H" and then reset Servo Microcomputer Q801 by Q919 "8 that is to set for Q919 "2 "H".

Next, when input through KEY of the Operation Buttons, Q804"44"58 is to be set at "H", turning ON Q908, Q909, Q910, Q911, and Q912 respectively; then, supply +B into the mechanism and the circuit. The power supply of the Transmitter Section detects wired connection or not for the system by means of Microcomputer Q804 setting Q804"56 at "H", in case of un-wired, while Q701" 2E turns in "H" and outputs 5V toward Q701"3V0.

While charging battery, its voltage increases up to around 14.6V, however, when completed charging, it decreases down to 13.6 V or so.

BATTERY CHARGING CIRCUIT

The changing current is to be applied to the battery by way of R903 and Q903 from AC Adapter. While charging, the current is detected by R909 and the base voltage of R905 is controlled (Charge Indicator is turned ON by the live Q905 while charging). At the end of charging, due to the R909 not charged, base voltage of Q905 increases to turn OFF Q905 and then Charge Indicator.

OVERDISCHARGE PREVENTION OF BATTERY

Microcomputer Q804"63 detects the poor capacity of the battery when its voltage falls down to approx. 10.6V turning Warning Light ON on the other hand. In case of lowere voltage, Microcomputer Q804"44 and "58 turn in "L" to start Q912 and Q919 to prevent +B from passing.

Although you take out AC Adapter with battery connection under POWER OFF, the back-up current (abt. 8 mA) to Microcomputer is still alive, and the battery is to be exhaussted (completely in a week or so).

CABINET DISASSEMBLY

1. Turn over the set.
2. Loosen out setscrews of the battery cover and then take the cover off.
3. Loosen out the 6 (siz) screws fixing Cabinet (TOP) and Cabinet (BASE).
4. Turn down the set.
5. Set up ANT and take off the cabinet (TOP).

BT-D1 (BATTERY)

1. CHARGING

Put two batteries into the Control Center (TU-D1) to connect to AC Adapter and then plug in for power supply to start charging (the Charge Indicator of Control Center will be turned ON). When completed charging, the said Light is to goes out. (Charging takes about four hours. Play back for two hours, while recording is not available)

NOTE: Charging for SU-X1 requires series arrangement of two batteries and therefore, if not discharge equally, (to be normal generally, when used for TU-D1, and so, when just one of the two batteries was used separately) the used one may not be charged. In such a case, charge one by one at the rated voltage of supply DC 7 V 800 mA.

After stored for a long time (12 months or more) or overcharged, it will be difficult to charge. This is because of the sulfate film caused on the electrode. In this case, charge for 12 to 24 hours and more to remove the sulfate film in order to be as new as a virgin battery.

2. DISPLAY

At shop, for first-in-first-out method, the display consists of 10-digit Serial NO., the four inferior of which are to show the Date of Manufacture:

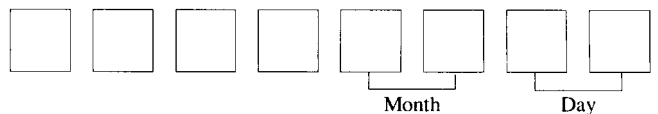

therefore, there can be some NO's with the same inferior four digits. Number of products and cartons (containing two products) is also displayed on the color label to be stuck to a larger package every six months.

November	91 to April	92	: Color label not stuck
May	92 to October	92	: Red label stuck
November	92 to April	93	: Yellow label to be stuck
May	93 to October	93	: Blue lable to be stuck
November	93 to April	94	: Orange label to be stuck
May	94 to October	94	: Green label to be stuck

3. LIFE OF CYCLE

Varies based on the discharge ondition.
 The more discharged, the less in cycle numbers.
 100% discharge – 200 times of charge/discharge
 50% discharge – 400 times of charge/discharge
 30% discharge – 1200 times of charge/discharge

PROTECTION OF EYES FROM LASER BEAM DURING SERVICING

This set employs a laser. Therefore, be sure to follow carefully the instructions below when servicing.

WARNING!!

WHEN SERVICING, DO NOT APPROACH THE LASER EXIT WITH THE EYE TOO CLOSELY. IN CASE IT IS NECESSARY TO CONFIRM LASER BEAM EMISSION, BE SURE TO OBSERVE FROM A DISTANCE OF MORE THAN 30cm FROM THE SURFACE OF THE OBJECTIVE LENS ON THE OPTICAL PICK-UP BLOCK.

LASER WARNING LABEL

The label shown below are affixed.

1. Warning labels

These labels are located on the back of the cabinet or the lid of the battery case.

- A**
- DANGER** —INVISIBLE LASER RADIATION WHEN OPEN AND INTERLOCK FAILED OR DEFEATED. AVOID DIRECT EXPOSURE TO BEAM
- CAUTION** —HAZARDOUS LASER AND ELECTROMAGNETIC RADIATION WHEN OPEN AND INTERLOCK DEFEATED
- ATTENTION** —RAYONNEMENT LASER ET ELECTROMAGNETIQUE DANGEREUX SI OUVERT AVEC L'ECLenchement DE SECURITE ANNULE.

Laser Diode Properties

- Material: GaAS/GaAlAs
- Wavelength: 780nm
- Emission Duration: continuous
- Laser output: max. 0.5mW*
 - *This output is the value measured at a distance about 1.8mm from the objective lens surface on the Optical Pick-up Block.

2. Certification label (120V model)

This label is located on the back panel.

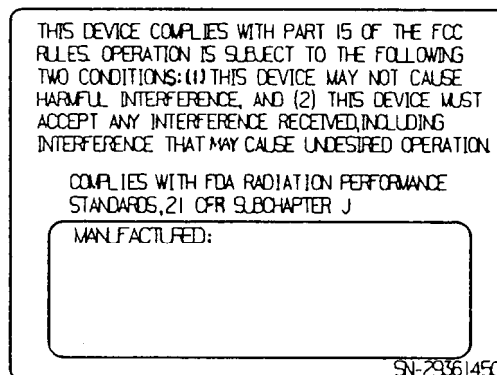

3. Class 1 label (Except 120V model)

This label is located on the back panel.

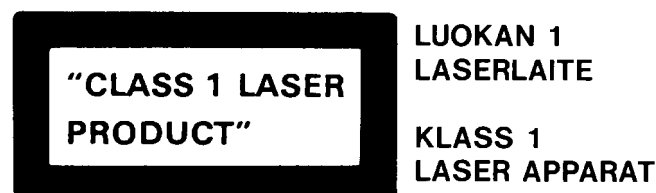

ADVARSEL

Denna mærkning er anbragt på apparatets højre side og indikerer, at apparatet arbejder med laserstråler af klasse 1, hvilket betyder, at der anvendes laserstråler af svageste klasse, og at man ikke på apparatets yderside kan blive udsat for utilsigelig kraftig stråling.

APPARATET BØ/R KUN ÅBNES AF FAGFOLK MED SÆRLIGT KENDSKAB TIL APPARATER MED LASERSTRÅLER!

Indvendigt i apparatet er anbragt den her gengivne advarselmærkning, som advarer imod at foretage sådanne indgreb i apparatet, at man kan komme til at udsætte sig for laserstråling.

VAROITUS! LAITTEEN KÄYTTÄMINEN MUULLA KUIN TASSA KAYTTOOHJEESSA MAINTULLA TAVALLA SAATTAÄ ALTISTAA KÄYTTÄJÄN TURVALLISUUSLUOKAN 1 YLITÄAVALLA NÄKYMÄTTÖMÄLLE LASERSÄTEILYLLE.

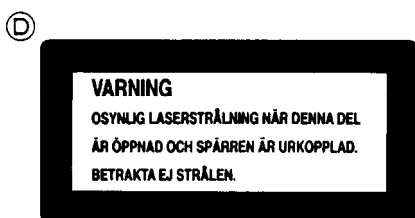
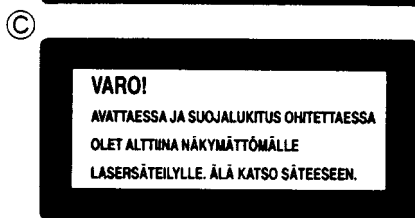
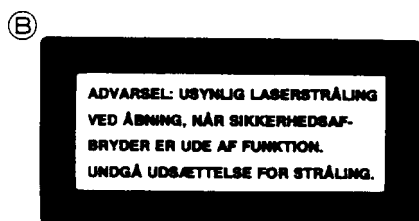

B C D 230V model only (Except Germany model)

BLOCK DIAGRAM

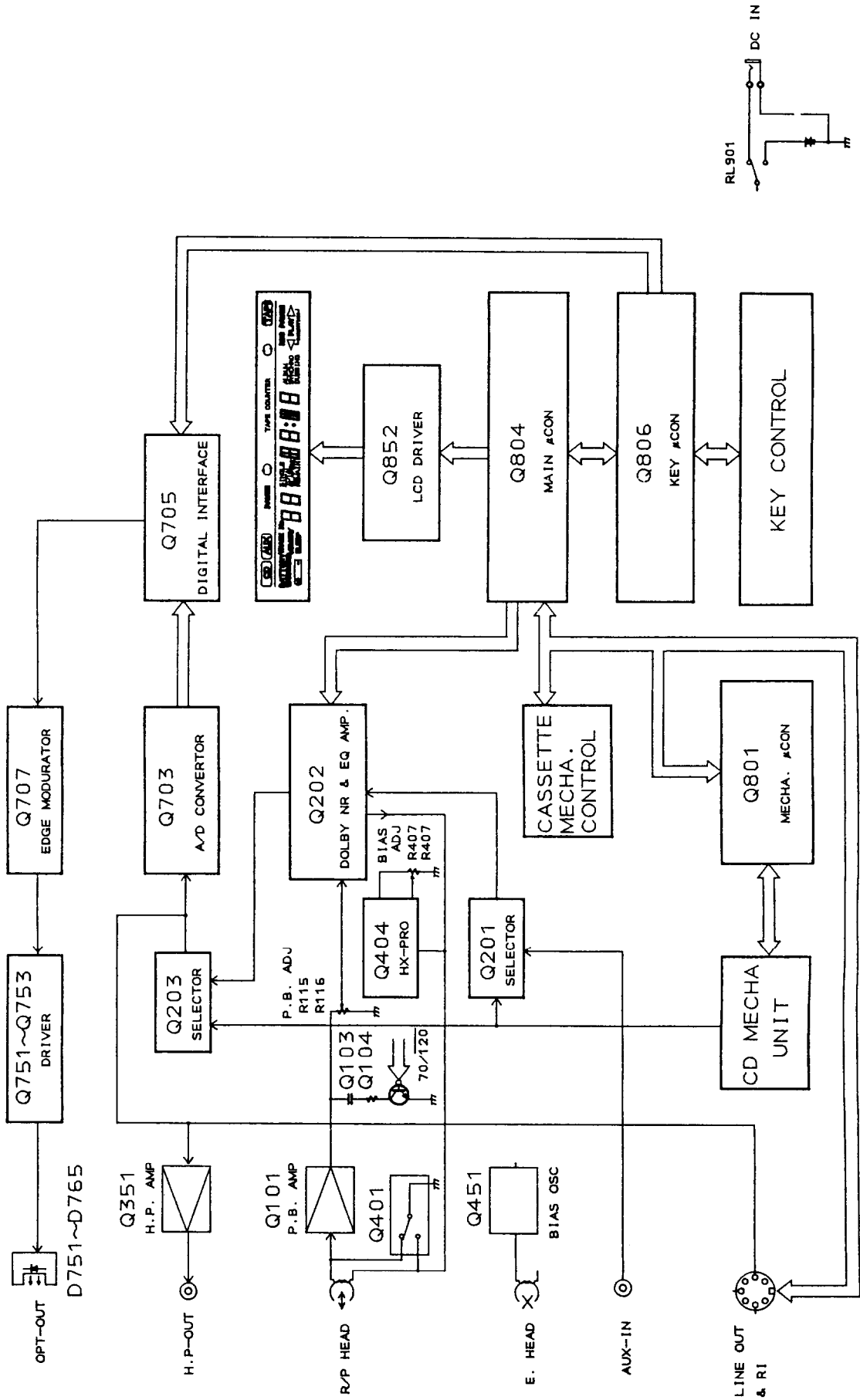

IC BLOCK DIAGRAM

TC4052BF (ANALOG SW)

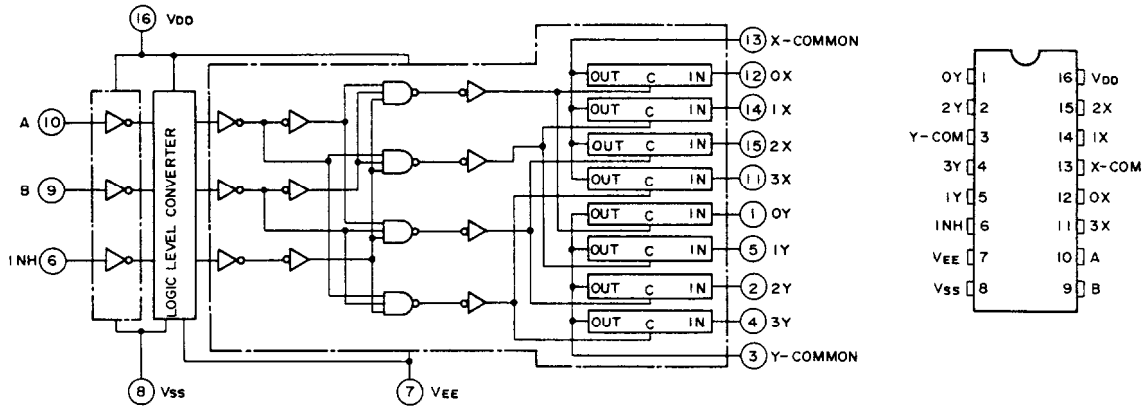

CONTROL INPUT			"ON" CHANNEL
INH	B	A	
L	L	L	0 X, 0 Y
L	L	H	1 X, 1 Y
L	H	L	2 X, 2 Y
L	H	H	3 X, 3 Y

HA12155NT (DOLBY-NR)

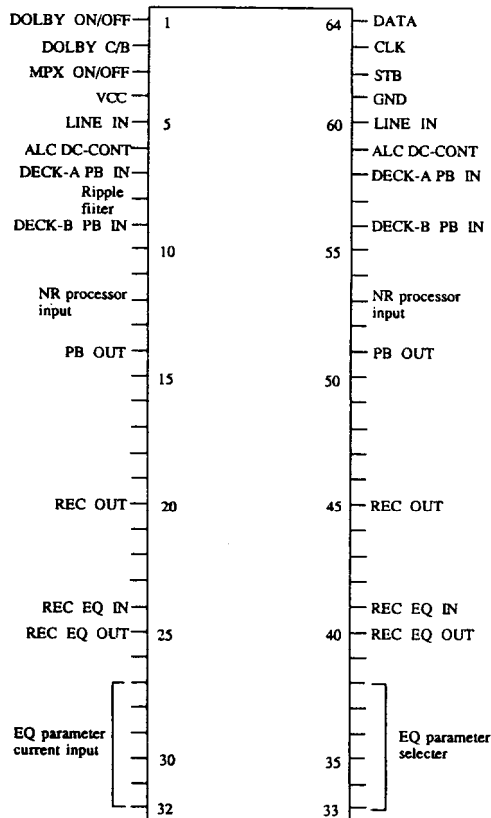

TA78DL05S (5V POWER SUPPLY)

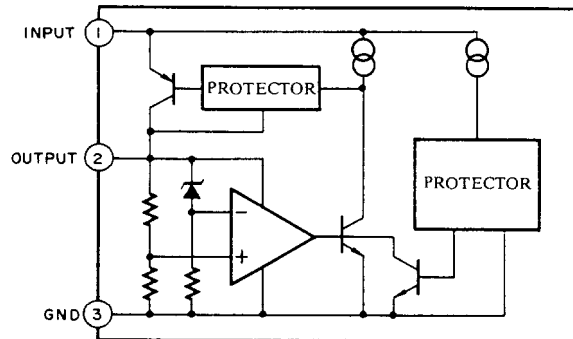

TC74HC74AP

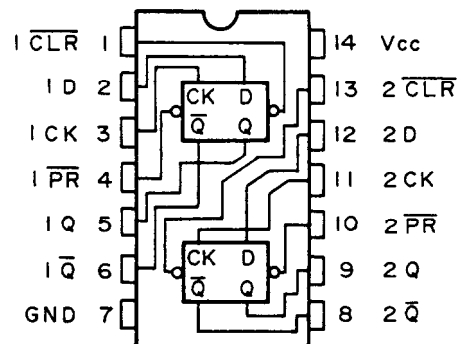

(TOP VIEW)

MICRO COMPUTER TERMINAL DESCRIPTION

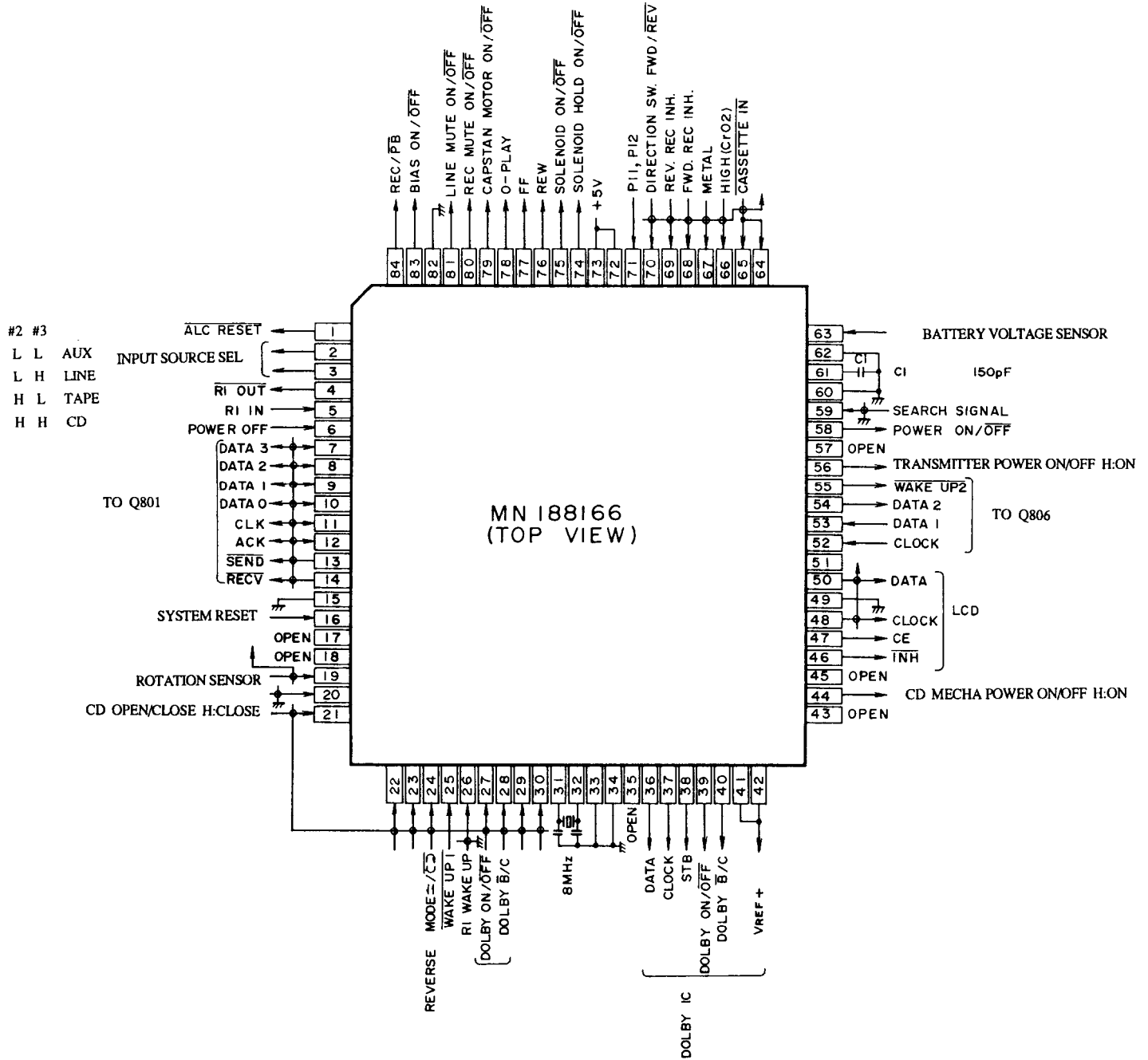

CIRCUIT NO.	PART NO.	DESCRIPTION
C403, C404	391980477	4.7 μ F50V
C417	391980107	1 μ F50V
C418, C419	391941007	10 μ F16V
C421	391924717	470 μ F16.3V
C455	391941007	10 μ F16V
C502	391941007	10 μ F16V
C901	391941017	100 μ F16V
C903	391941007	10 μ F16V
C905	391980477	4.7 μ F50V
C905	391941007	10 μ F16V
C907	391944717	470 μ F16V
C908	391980227	2.2 μ F50V
C911, C912	391941007	10 μ F16V

Resistors

R115, R116	5210218	N06HR20KBD
R229, R230	5210218	N06HR20KBD
R407, R408	5210217	N06HR10KBD
R453	442522204F	RS1/2WBJ 22 Ω
R503	442524704F	RS1/2WBJ 47 Ω
R513	442623904F	RS1WBJ 39 Ω
R833	49163472406	RM1/101J4.7k \times 6
R909	442528294F	RS1/2WBJ 0.82 Ω
R925	5210217	N06HR10KBD
R943	442521204F	RS1/2WBJ 12 Ω

Plug, socket

P101	25050730	NSCT-8P534
P102	25055136	NPLG-6P120
P201	25045360	NPJ-2PDWH206
P202	25065414	NSS-22155
P251A	2000665	NSAS-8P621
-P301	25050525	NSCT-3P348
P401	25055132	NPLG-2P116
P302A	2009990251	NSAS-3P0364
P701	2009990257	NSAS-20P0373
P303	25050525	NSCT-3P348
P801A	25050732	NSCT-23P536
P802	25050525	NSCT-3P348
P803A	25050731	NSCT-15P535
P804	25055146	NPLG-2P130
P805	25055146	NPLG-2P130
P851	2006323015	NSAS-30P0358
P852A	25055150	NPLG-6P134
P901	25050729	NSCT-3P533

Miscellaneous

25050065	YSH403T, FESE HOLDER
27160179	RAD-57, RADIATOR
27160145	RAD-51, RADIATOR
82143006	3P+6FNBC, SCREW

NADG-4423-2

CIRCUIT NO.	PART NO.	DESCRIPTION
ics		
Q701	22240534	LA5601
Q702	22240608R1	NJM2100M
Q703	22240579R2	CS5349KS
Q704	222740045R1TO	TC74HCU04AF
Q705	22240580R2	YM3437C-F
Q706	222740745R1TO	TC74HC74AF
Q707	222740865R1TO	TC74HC86AF
Transistors		
Q708	2214363 or 2214363	2SC4455R or 2SC4455Q
Diode		
D705	223205	1SS270A
Coil		

CIRCUIT NO.	PART NO.	DESCRIPTION
L701	230913R2	BLM31A02PT
Ceramic OSC		
X701	3010193	CST11.2MTW040
Capacitors		
C705-C710	391980477	4.7 μ F50V
C716	391944707	47 μ F16V
C718	391982297	0.22 μ F50V
C719	391980477	4.7 μ F50V
C720, C721	391944707	47 μ F16V
C722	391981097	0.1 μ F50V
C724	391980477	4.7 μ F50V
C727	391941007	10 μ F16V
C729	391980477	4.7 μ F50V
C733	391941007	10 μ F16V
C734	391981097	0.1 μ F50V
C738	391941007	10 μ F16V
C750	352982296S	0.22 μ F50V

Plug

P701	25055154	NPLG-10P138
P702	25055147	NPLG-3P131

NAAF-4424-2

CIRCUIT NO.	PART NO.	DESCRIPTION
Resistor		
R351, R352	5104302	N08RGL5KA01Z, VARIABLE
Jack		
P351	25045310	LGS6517-0206

NASW-4425-2

CIRCUIT NO.	PART NO.	DESCRIPTION
S802	25065297	NSS-23119, SWITCH
S803	25065364	NSS-12138, SWITCH
P251	25055226	NPLG-4P210, PLUG

NASW-4426-2

CIRCUIT NO.	PART NO.	DESCRIPTION
S801	25035640	NPS-111-S594, SWITCH

NAPS-4427-2

CIRCUIT NO.	PART NO.	DESCRIPTION
P950A	25055133	NPLG-3P117, PLUG

NAPS-4428-2

CIRCUIT NO.	PART NO.	DESCRIPTION
P951A	25055133	NPLG-3P117, PLUG

NADIS-4429-2

CIRCUIT NO.	PART NO.	DESCRIPTION
ics		
Q852	22240675R3	LC7582E
LCD		
Q851	24190032	LCD8207PR
LED		
D451	225141	SEL2213C
Switch		
S851-S880	25035639R2	NPS-111-S593
Plug, socket		
P851	25055159	NPLG-15P143

CIRCUIT NO.	PART NO.	DESCRIPTION
P852	2006321215	NSAS-12P0359

NAETC-4430-2

CIRCUIT NO.	PART NO.	DESCRIPTION
Q751-Q753	Transistor	
	2214364 or 2214363	2SC455R or 2SC455Q
D751-D765	LED	
	225277	SID1H10CXM
C751	Capasitor	
	354742219S	220 μ F16V
	Holder	
	27190878	HOLDER (LED)

NAAF-4537-2

CIRCUIT NO.	PART NO.	DESCRIPTION
R351, R352	5104302	N08RGL5KA, VARIABLE
P351	25045310	LGS6517-0206

NAETC-4562-2

CIRCUIT NO.	PART NO.	DESCRIPTION
Q721, Q722	Transistor	
	2211705 or 2211706	2SD655E or 2SD655F
Q723, Q724		
	2212600 or 2213580	DTA124ES or RN2203
C322	Capasitor	
	391980477	4.7 μ F50V
P302	Plug	
	25055367	NPLG-3P350

ADJUSTMENT PROCEDURES (CASSETTE DECK)

PRECAUTIONS

- Before adjustment, clean the following parts with an alcohol moistened swab.
 - * record/playback head
 - * pinch roller
 - * erase head
 - * capstan
- Do not use magnetized screwdriver for adjustments.
- Demagnetize record/playback head with a head demagnetizer.

TEST EQUIPMENT/TOOLS REQUIRED:

Audio oscillator
 Digital frequency counter
 Oscilloscope
 Attenuator
 AC voltmeter
 Non-magnetic screw driver
 Test tapes
 TCC-153 : 10 KHz, - 5dB
 MTT-111 : 3 kHz, - 0dB
 MTT-150 : Dolby level calibration
 400Hz, tone 200nWb/m

Item	Connection of instrument	Line input	Test tape	Mode	Output indicator	Adjustment point	Adjust	Remarks
1	Tape speed	Frequency counter to LINE output terminal	MTT-111	PB	Frequency counter	Semi-fixed on the motor	3,000 to 3,010Hz	
2	Head azimuth	AC voltmeter and oscilloscope to LINE output terminal	TCC-153	PB	AC voltmeter	Head azimuth screw FWD ... left REV ... right	Maximum and same phase at channels L and R	See fig.1
3	Playback level	AC voltmeter to terminals TP-1 and TP-2	MTT-150	PB	AC voltmeter	R-115 (Ch. L) R-116 (Ch. R)	300mV	
4	Bias current	Fig. 2	1KHz, -20dB and 12kHz, -20dB	UD-1 C-90	REC/PB	AC voltmeter	R-407 (Ch. L) R-408 (Ch. R)	Same level at REC/PB
5	Record level	Fig. 2	2	1 KHz	REC PAUSE	AC voltmeter	Attenuator or AF OSC output	P101 LINEOUT 160mV
					REC/PB	AC voltmeter	R-229 (Ch. L) R-230 (Ch. R)	
6	Battery charge voltage	Fig.3			DC voltmeter	R-925	13.65V ± 0.05V	

Blank tape

NORMAL NEW UD-1 C-90
 HIGH XL-II C-90
 METAL XS C-60
 FF.REW torque 90~180g/cm
 PLAY torque 30~70g/cm
 Back tension 2~6g/cm

ADJUSTMENT POINT

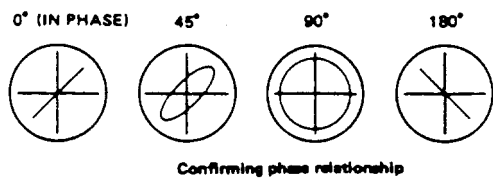
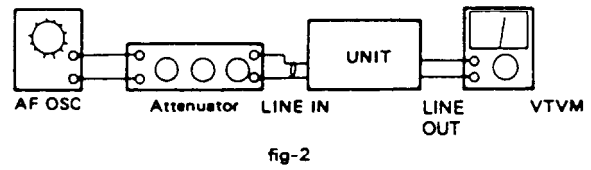
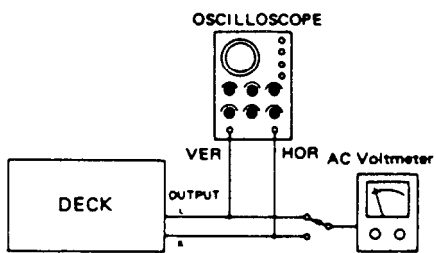
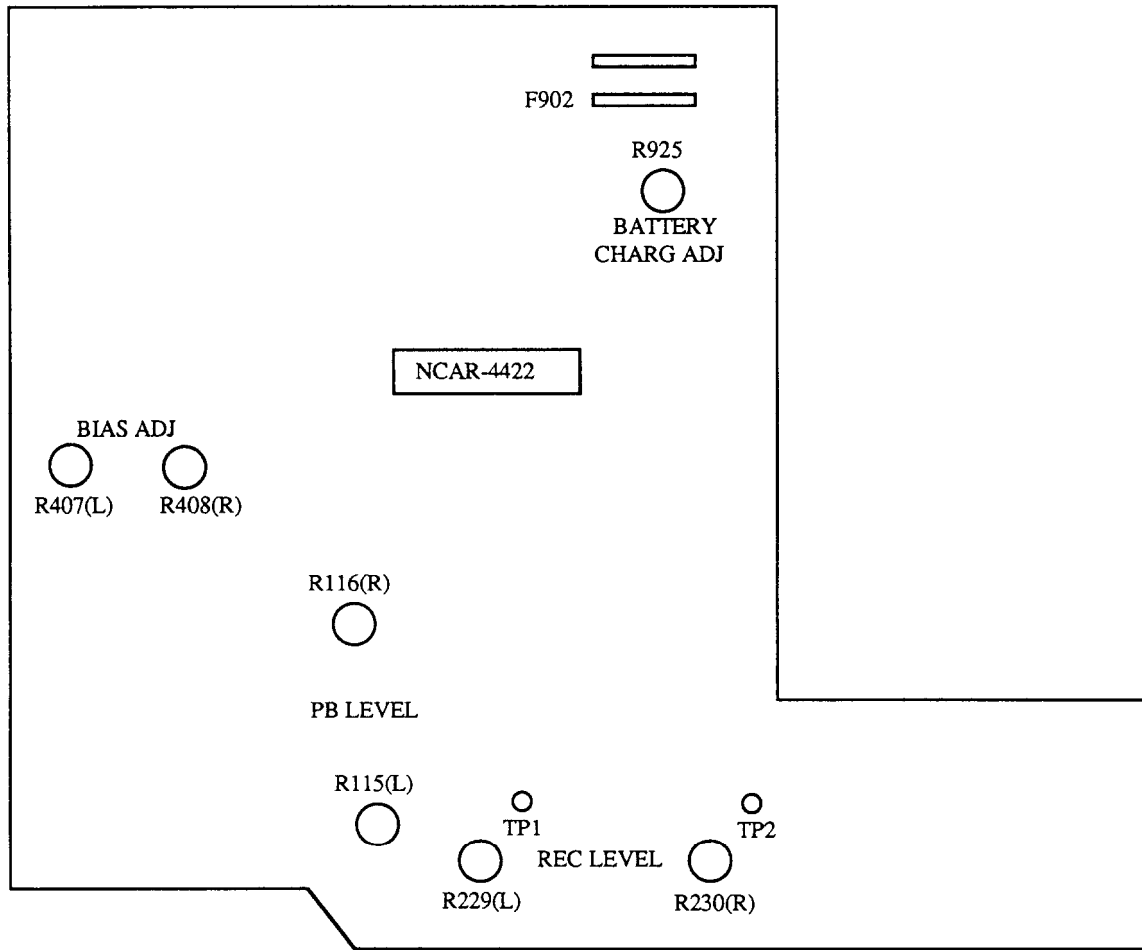

fig-1

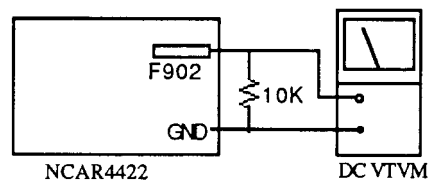
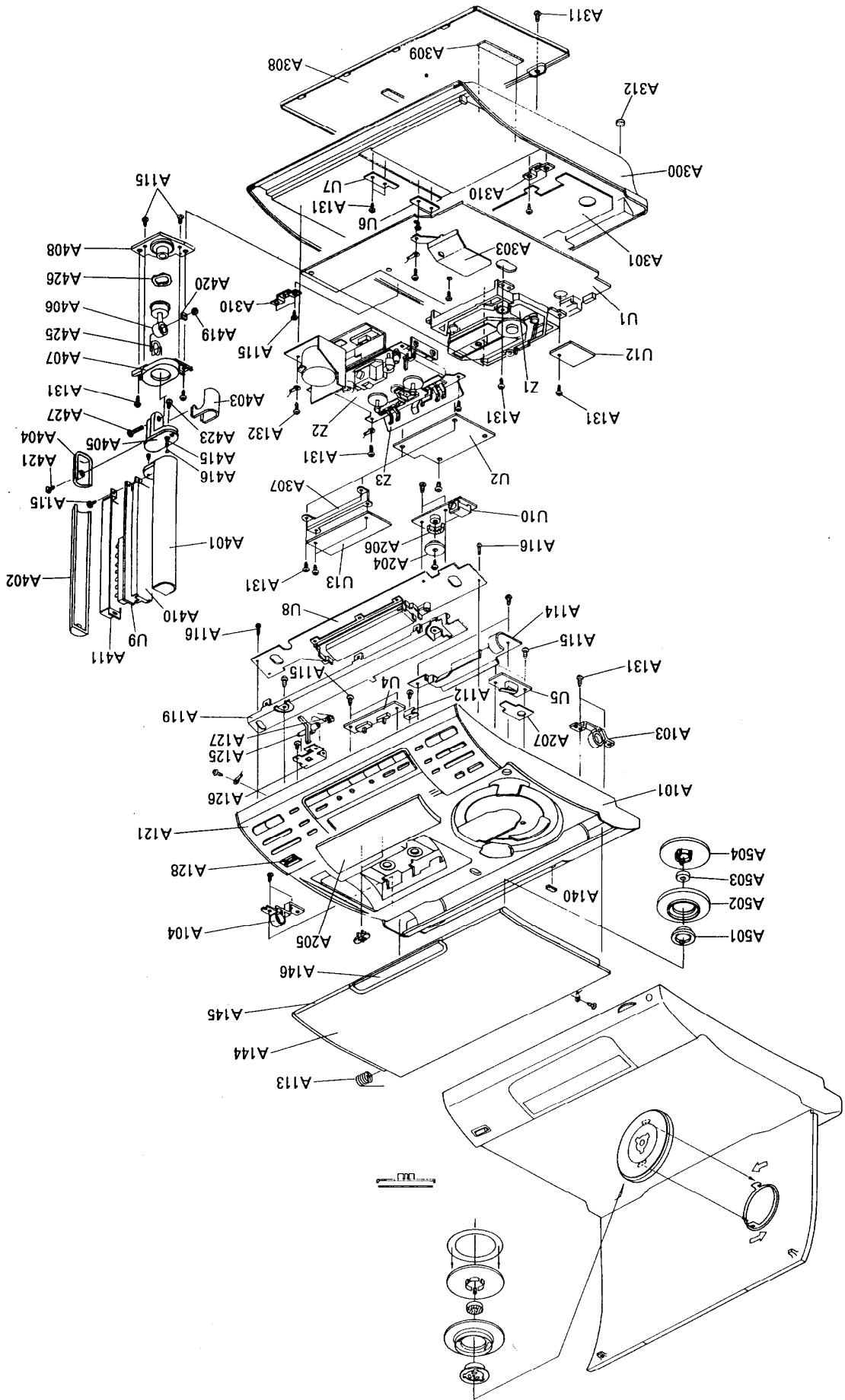

fig-3



CHASSIS-EXPLODED VIEW

A B C D E

1 2 3 4 5 6 7 8

11

11

CD MECHANISM-EXPLODED VIEW

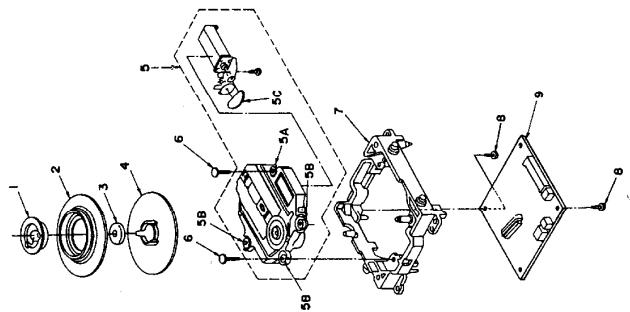

REF. NO.	PARTS NO.	DESCRIPTION
1	24824001	clammer
2	24826003	holder
3	24832002	magnet
4	24826005	disc holder
5	24800003	traverse AS
5a	24818002	floating cushion (A)
5b	24818003	floating cushion (B)
5c	24816002	belt
6	24840006	pin
7	24802002	chassis
8	801499	screw
9	24505342	printed circuit board AS

TAPE MECHANISM PARTS LIST

REF. NO.	PARTS NO.	DESCRIPTION
2-1	24602482	IDLER AS
2-2	24601245	REEL MOTOR
2-3	24611519	CHASSIS BASE AS
2-4	24602483	BASE AS (REEL)
2-5	24602484	BASE AS (REEL)
2-7	24609032	PAN HEAD SCREW 2.6 x 6.4ZN
2-8	24611177	PLASTIC WASHER 1.7 x 3.2 x .25
2-11	24611175	PLASTIC WASHER 2.1 x 7 x .25
3	24611520	HEAD PLATE AS
3-3	24605766	SPRING
3-3-9	24609053	SCREW 1.7 x 5.2NT
3-3-10	24611521	HOUSING AS (HEAD)
3-5	24611493	BASE (HEAD)
3-7	24609054	SCREW 1.4 x 5.4NT
3-8	24605765	SPRING (DOOR)
3-9	24605711	SPRING
3-11	833120059	TAPPING SCREW 2 x 5ZN
3-17	24606499	SOLENOID COIL
3-19	25055146	NPLG-2P130
4	24601270	MAIN MOTOR AS
5	24606490	P.C.B. (CONTROL)
5-12	24606491	LEAD WIRE (2P)
5-13	24606494	SG-107F3
5-14	24606492	JUMPER WIRE (2P)
5-15	24606493	JUMPER WIRE (15P)
5-17	24606271	PUSH SWITCH
8	24605717	SPRING
9	24611384A	SLIDE PLATE
12	24607116	ARM (PLAY)
14	24602550	CAM GEAR
15	24603365A	LEVER (REC)
16	24603387	LEVER (PAC) P
17	24603367	LEVER (METAL) L
18	24602551	MAIN BELT
20	24611041	PLASTIC WASHER 2.6 x 0.25
23	24610841	PLASTIC WASHER 2.6 x 4.7 x .5
26	24605716	SPRING
29	24602552	FLYWHEEL AS
30	24602545	FLYWHEEL AS
31	24602414C	PINCH ROLLER AS (R)
32	24602421C	PINCH ROLLER AS
39	8930151	E WASHER 1.5S
40	24609055	SCREW
51	24606333	SOLENOID COIL AS
52	24606332A	CORE
53	24606331	PLANGER
61	24607121	MOTOR BRACKET
62	833130059	TAPPING SCREW CT3 x 5
63	833126049	TAP-TIGHT SCREW 2.6TTP+4C
64	24609056	SCREW (MOTOR)
65	24611523	CUSHION (MOTOR)
66	24602553	MAIN BELT
67	2461188A	WASHER (OIL SEAL)
68	24610844	WASHER 1.9 x 5 x 0.25
71	24611524	PLASTIC WASHER 2.1 x 0.13
72	24611525	PLASTIC WASHER 2.1 x 0.25
73	24604100	LOCK WASHER
74	24604100	SHAFT
76	24609057	TP SCREW
77	24602554	MOTOR PULLEY
84	24606495	WIRE CONNECTOR (R/P/E)

TAPE MECHANISM CONNECTION DIAGRAM

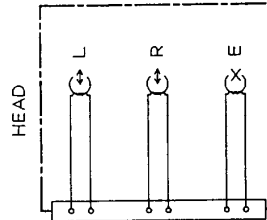
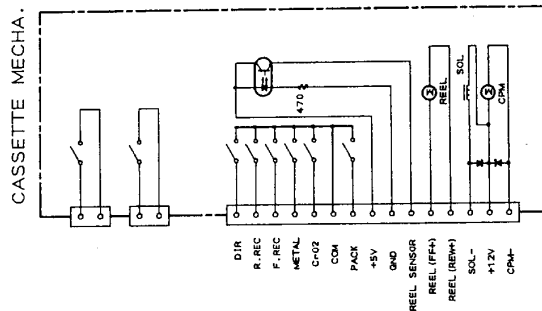

TAPE MECHANISM-EXPLODED VIEW

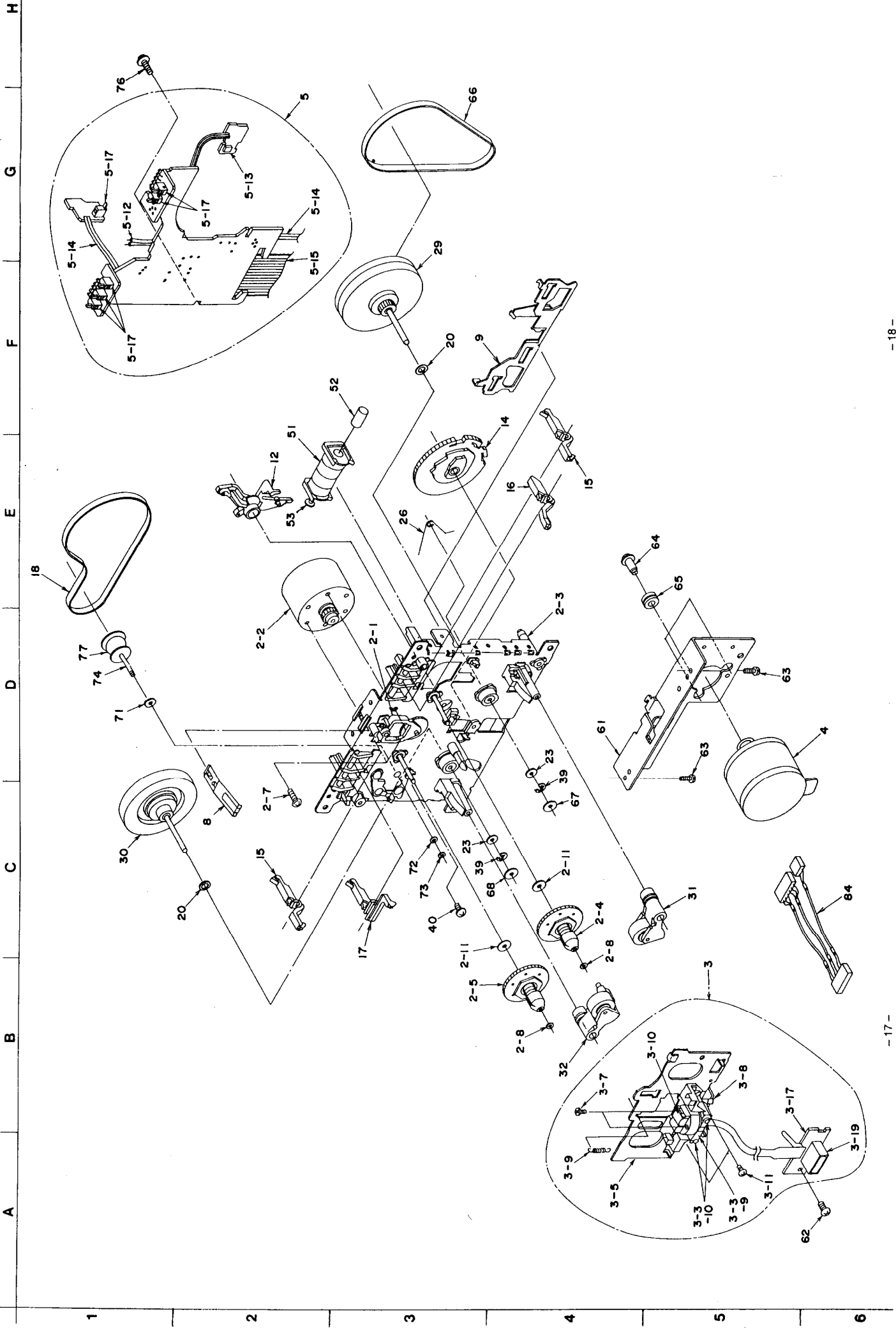

SCHEMATIC DIAGRAM 1/4

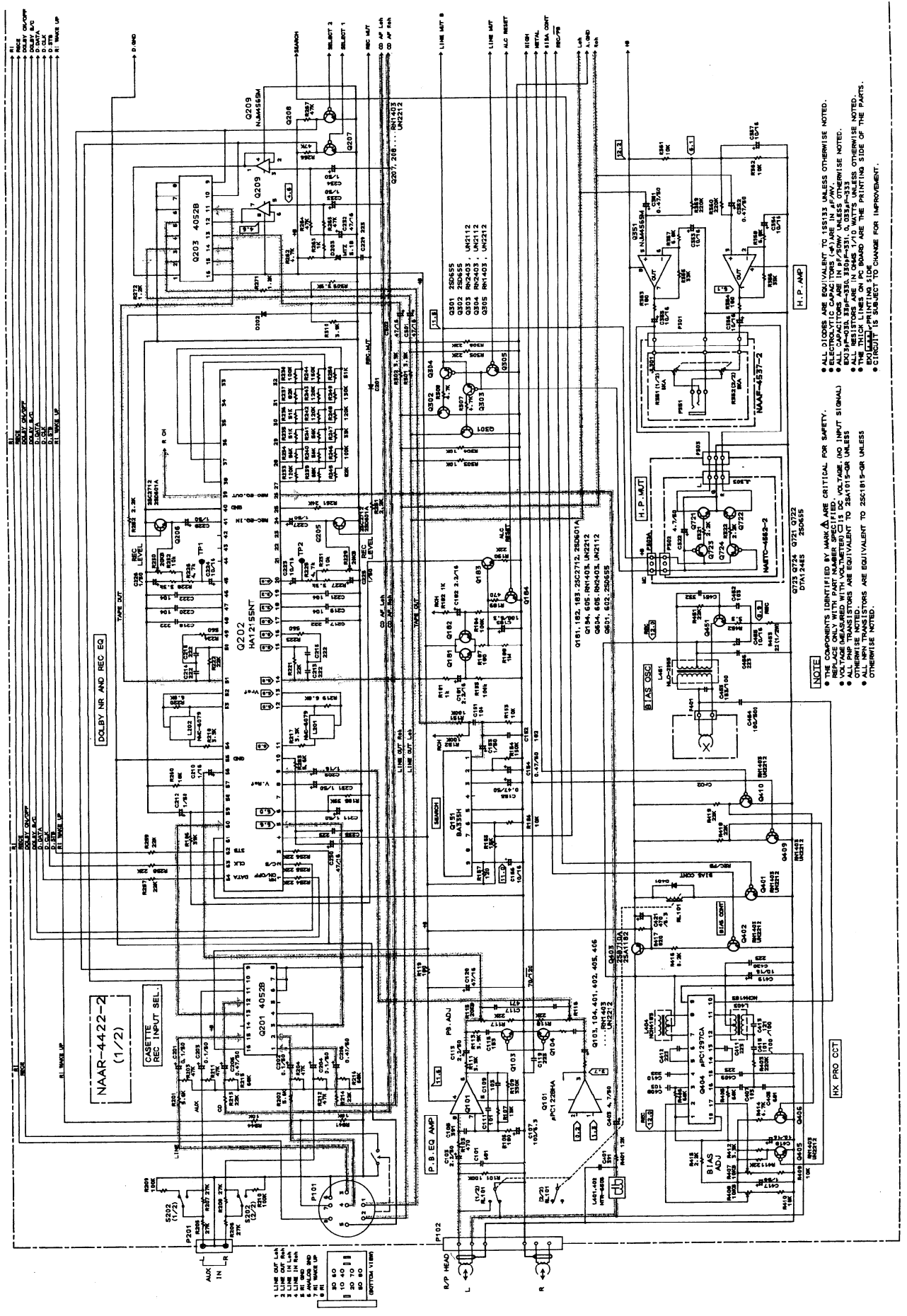

NOTE

- THE COMPONENTS IDENTIFIED BY MARK Δ ARE CRITICAL FOR SAFETY.
- REPLACE ONLY WITH PART NUMBER SPECIFIED. VOLTAGE (NO INPUT SIGNAL).
- ALL PNP TRANSISTORS ARE EQUIVALENT TO 2N4101-5 OR UNLESS OTHERWISE NOTED.
- ALL MOSFETS ARE EQUIVALENT TO 2SC1815-OR UNLESS OTHERWISE NOTED.
- ALL DIODES ARE EQUIVALENT TO 1N4148 UNLESS OTHERWISE NOTED.
- ELECTROLYTIC CAPACITORS IN THIS CIRCUIT ARE 50% TOLERANCE UNLESS OTHERWISE NOTED.
- ELECTROLYTIC CAPACITORS IN THE POWER SUPPLY ARE 20% TOLERANCE UNLESS OTHERWISE NOTED.
- THE TRAILING LINE ON PC BOARD ARE THE PRINTING SIDE OF THE PARTS.
- BOLD PRINTING IS USED FOR THE PRINTING SIDE OF THE PARTS.
- CIRCUIT IS SUBJECT TO CHANGE FOR IMPROVEMENT.

SCHEMATIC DIAGRAM 2/4

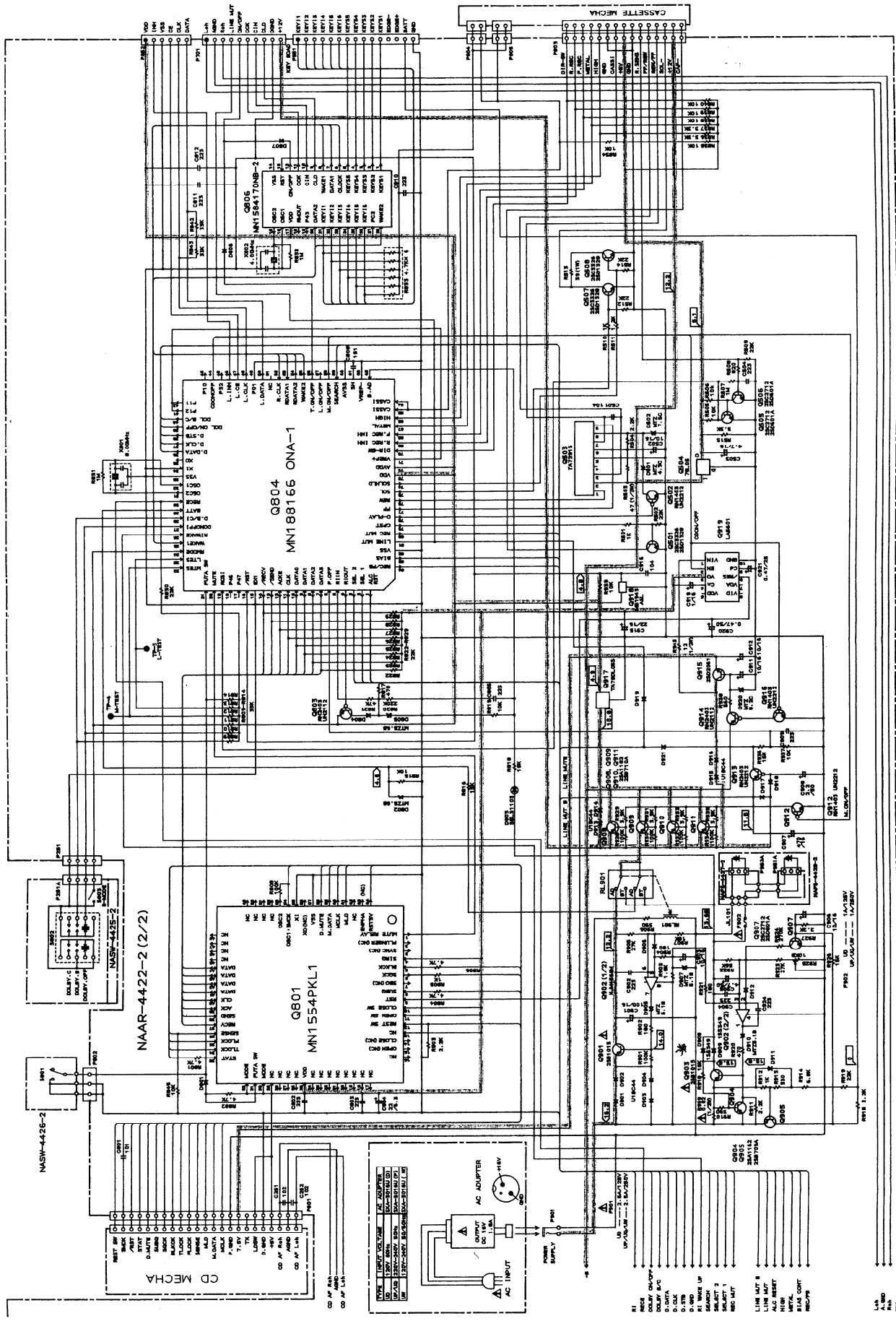

SCHEMATIC DIAGRAM 3/4

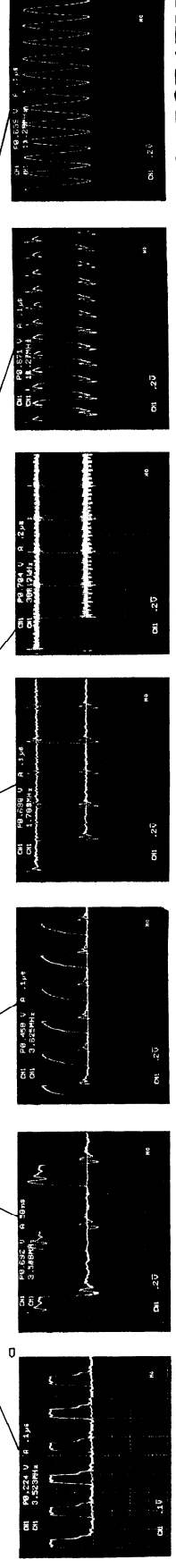
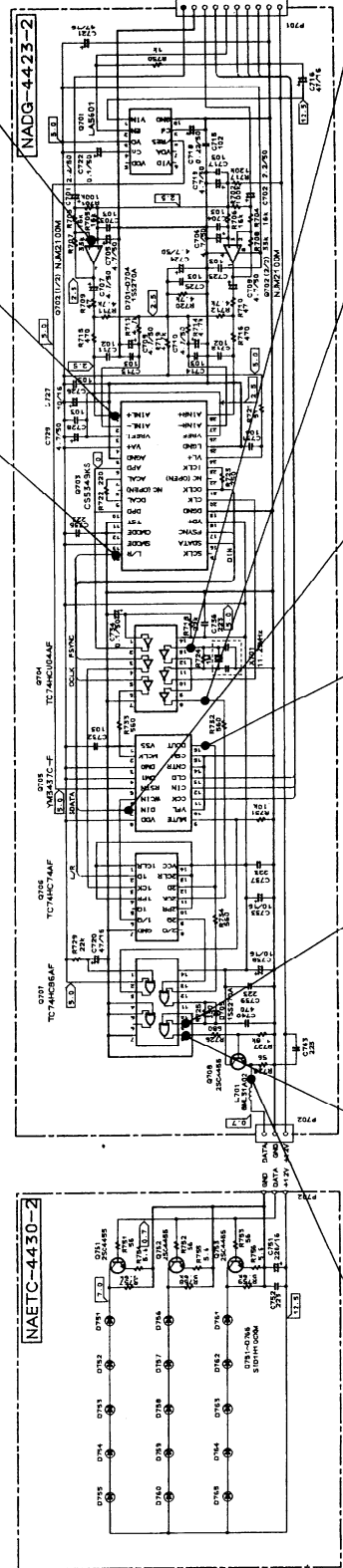
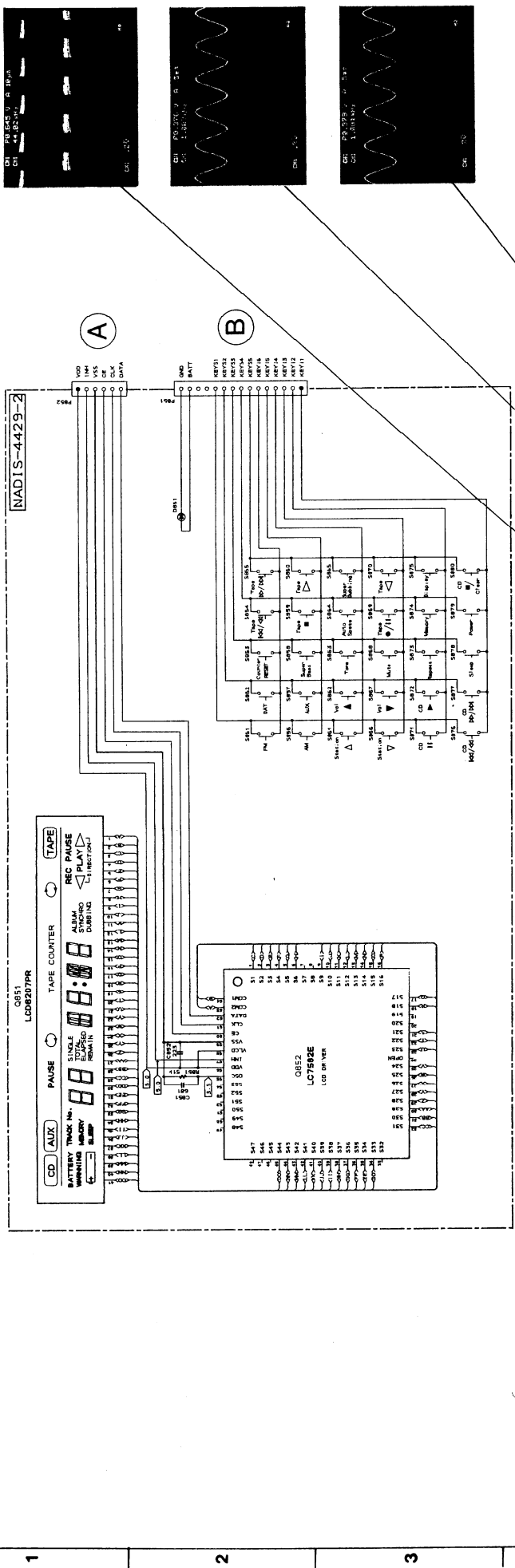

SCHEMATIC DIAGRAM 4/4

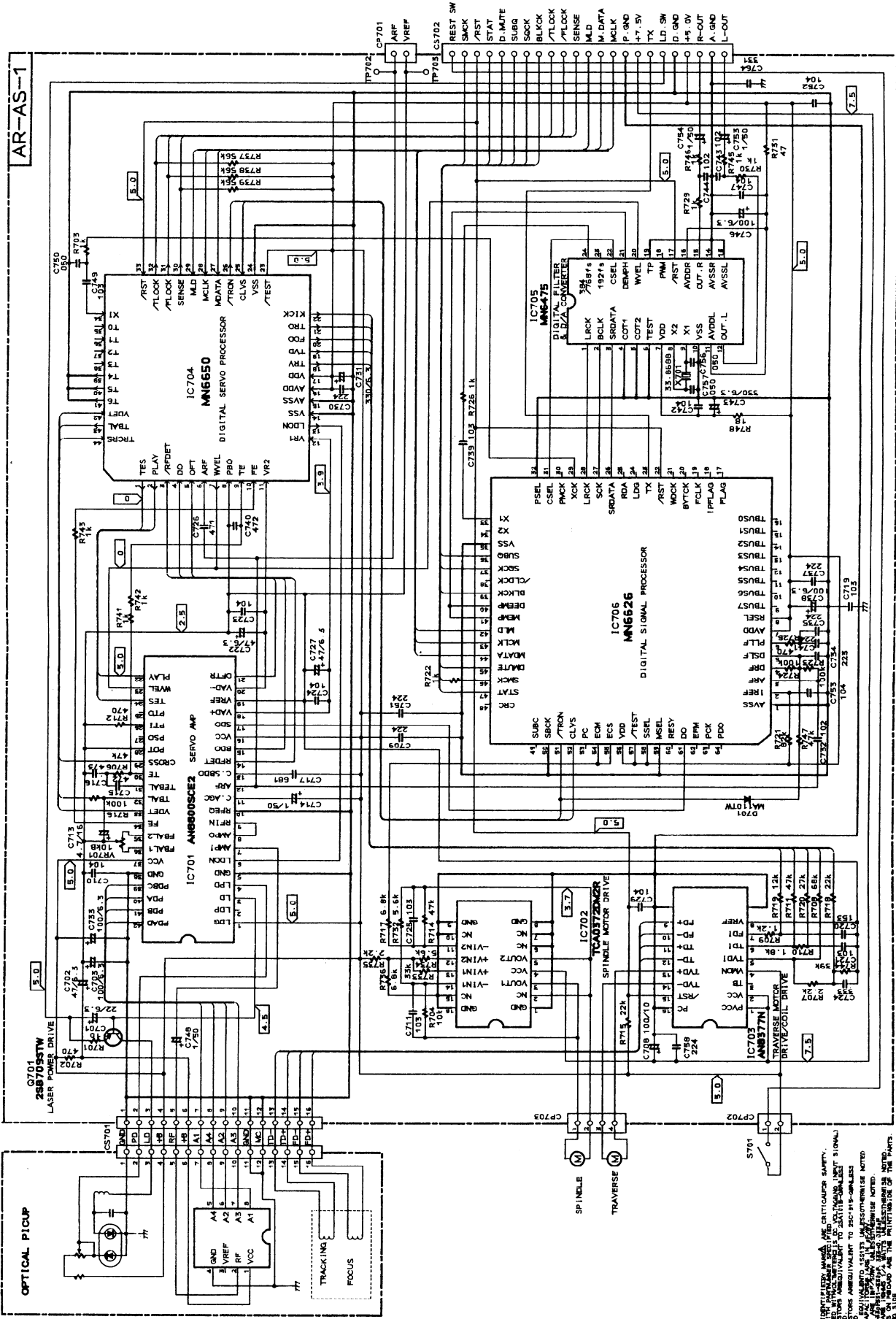

NOTE: THE COMPONENTS WITHIN THIS BOARD ARE CRITICAL TO SAFETY. ALL COMPONENTS MUST BE REPLACED WITH IDENTICAL PARTS. THE PARTS LISTED IN THIS SCHEMATIC ARE THE ONLY PARTS WHICH SHOULD BE USED. THE PARTS LISTED IN THIS SCHEMATIC ARE THE ONLY PARTS WHICH SHOULD BE USED. THE PARTS LISTED IN THIS SCHEMATIC ARE THE ONLY PARTS WHICH SHOULD BE USED.

IC BLOCK DIAGRAM

CS539-KS (A/D Converter)

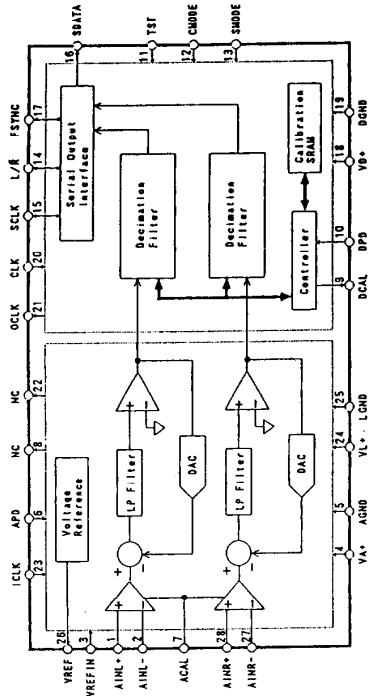

YM 3437C-F (Digital interphase)

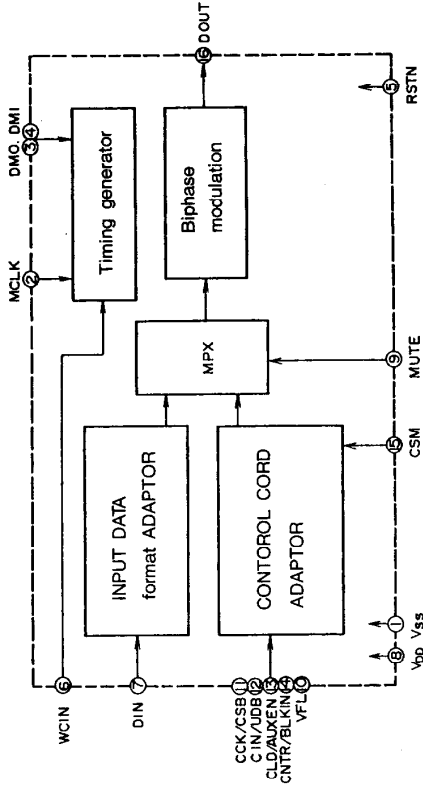

ONKYO CORPORATION

International Division
 Onkyo France S.A.R.L.
 Immeuble Le DIAMANT, Domaine Technologique De
 Sacylay 4 rue Rene Raziol, 91892 SACLAY, FRANCE
 Tel: (1) 69 41 35 10 Fax: (1) 69 41 35 84
 ONKYO U.S.A. CORPORATION
 200 Williams Drive, Ramsey, N.J. 07446, U.S.A.
 Tel: 201-825-7950 Fax: 201-825-8150
 ONKYO DEUTSCHLAND GMBH ELECTRONICS
 Industriestraße 20, 8034 Gerning, GERMANY
 Tel: 089 84 93 20 Fax: 089 84 93 226

