

ONKYO® SERVICE MANUAL

SERVO LOCKED TUNER AMPLIFIER MODEL TX-20

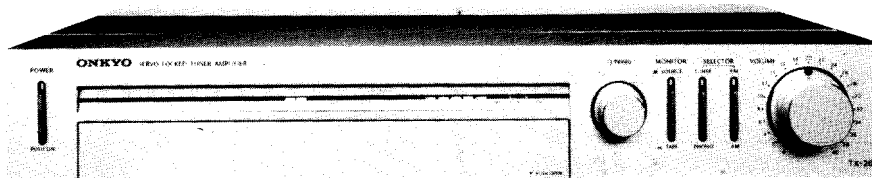

TABLE OF CONTENTS

Item	Page
Specifications	2
Service procedures	3
Exploded view	4
Block diagram	5
Circuit description	5
Component location	7
Alignment procedures	8
Stringing diagram	9
Pc board-parts list (220V model)	10
Schematic diagram (220V model)	11
Pc board view 220V model)	13
Pc board view (120V model)	15
Schematic diagram (120V model)	17
Pc board-parts list (120V model)	19
Packing procedures	20



SPECIFICATIONS

AMPLIFIER SECTION

Output Power:	30 watts per channel, min. RMS, at 8 ohms both channels driven, from 20 Hz to 20,000 Hz, with no more than 0.08% total harmonic distortion.
Dynamic:	84 watts total at 8 ohms 0.08% T.H.D.
Continuous:	33W + 33W (8 Ω , 1 kHz, 0.08% T.H.D.)
Total Harmonic Distortion:	0.08% at rated power 0.04% at 1 watt output
IM Distortion:	0.08% at rated power 0.04% at 1 watt output
Damping Factor:	40 at 8 ohms
Frequency Response:	20 Hz — 20,000 Hz (\pm 1 dB)
RIAA Deviation:	20 Hz — 20,000 Hz (\pm 0.8 dB)
Sensitivity & Impedance:	Phono: 3 mV, 50 kohms Tape Play: 150 mV, 50 kohms Tape Rec: 150 mV, 2.2 kohms (PH)
Phono Overload:	200 mV r.m.s. at 1 kHz, 0.08% T.H.D.
Signal-to-Noise Ratio:	Phono: 82 dB (at 10 mV input IHF A weighted) 65 dB (IHF C weighted) Tape: 95 dB (IHF A weighted) 90 dB (IHF C weighted)
Tone Controls:	Bass: \pm 9 dB at 100 Hz Treble: \pm 9 dB at 10 kHz
High Filter:	6 kHz (6 dB/oct)
Loudness:	+6 dB at 70 Hz +5 dB at 10 kHz

TUNER SECTION

FM:	
Tuning Range:	88 — 108 MHz (120V model)
Tuning Range:	87.5 — 108 MHz (220V model)
Usable Sensitivity:	Mono: 1.9 μ V (10.8 dBf) 1.4 μ V (S/N 26 dB, 40 kHz Devi.) DIN Stereo: 4 μ V (17.2 dBf) 45 μ V (S/N 46 dB, 40 kHz Devi.) DIN
50 dB Quieting Sensitivity:	Mono: 3.5 μ V (16.0 dBf) Stereo: 35 μ V (36.0 dBf)
Intermediate Frequency:	10.7 MHz
Capture Ratio:	1.5 dB
Image Rejection Ratio:	70 dB
IF Rejection Ratio:	85 dB
Spurious Rejection Ratio:	90 dB
Single-to-Noise Ratio:	Mono: 72 dB Stereo: 66 dB
Alternate Channel Att.:	55 dB 75 dB (IHF) (\pm 400 kHz)
Selectivity:	55 dB (DIN) (\pm 300 kHz, 40 kHz Devi)
AM Suppression Ratio:	50 dB
Harmonic Distortion:	Mono: 0.12% (120V model) Stereo: 0.3%
Harmonic Distortion:	Mono: 0.15% (220V model) Stereo: 0.4%

Frequency Response:	30 Hz — 15,000 Hz (\pm 1.5 dB)
Stereo Separation:	40 dB at 1 kHz 30 dB at 100 Hz — 10,000 Hz
Muting Level:	3 μ V (14.7 dBf)
Stereo Threshold:	3 μ V (14.7 dBf)
Servo Lock Level:	3 μ V (14.7 dBf)

AM:

Tuning Range:	525 — 1,605 kHz
Usable Sensitivity:	25 μ V
Intermediate Frequency:	455 kHz
Image Rejection Ratio:	45 dB
IF Rejection Ratio:	30 dB
Signal-to-Noise Ratio:	40 dB
Harmonic Distortion:	0.8%

GENERAL (120V model)

Power Supply:	AC 120 volts, 60 Hz
Outputs:	Speaker A & B, Phones, Tape Rec, AC Outlet
Inputs:	Phono, Aux, Tape Play, FM and AM Antennas
Antennas:	FM: 300 ohms balanced AM: built-in ferrite core antenna and external terminal
Semiconductors:	3 FETs, 19 transistors, 8 ICs, 25 diodes
Dimensions (WxHxD):	418 x 75 x 340 mm 16-9/16" x 2-61/64" x 13-7/16"
Weight:	7.2 kg, 15.8 lbs

GENERAL (220V model)

Power Supply:	AC 220 volts, 50 Hz
Outputs:	Speaker A & B, Phones, Tape Rec
Inputs:	Phono, Aux, Tape Play, FM and AM Antennas
Antennas:	FM: 300 ohms balanced AM: built-in ferrite core antenna and external terminal
Semiconductors:	3FETs, 21 transistors, 8 ICs, 29 diodes
Dimensions (WxHxD):	418 x 75 x 340 mm 16-9/16" x 2-61/64" x 13-7/16"
Weight:	7.2 kg, 15.8 lbs

Specifications and features are subject to change without notice.

SERVICE PROCEDURES

1. Front Panel (S) Replacement

- Turn the set over and remove the bond on the bottom of the (L) and (R) bearings with a knife.
- Return the set to the upright position and open the front panel (S). Then, following the central rib on the center of the front panel (S), slide the bearings from which the glue was removed toward the inner side. The front panel (S) will disengage from the front panel ass'y.
- Insert bearings (L) and (R) in the front panel (S) and attach so that bearing (R) is even with the front panel (S). Next, insert in the side panel (SR), then insert bearing (L) in side panel (SL) and attach so that it is even with the front panel (S). Finally, affix the bearings with bond (575).
- Attach the cushions to bearings (L) and (R).

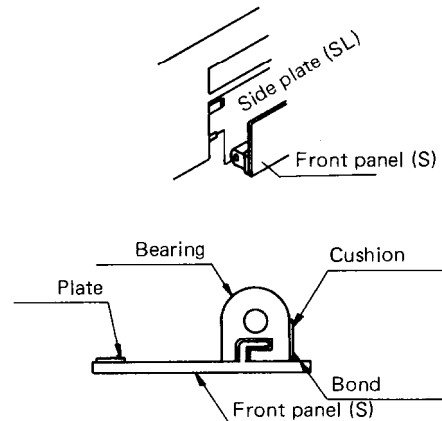

(fig. 1)

2. Top Panel and Side Panel Replacement

Always be sure to install the top panel before the side decorations. Also, when installing the top panel, attach (hook) the top panel to the heat sink as shown in the exploded view. When installing the side panel perform the operations in the order shown on the exploded view.

3. L.E.D. Replacement

- Remove the top cover and front panel.
- Remove the BASS, TREBLE, and BALANCE knobs. If they can not be removed easily, wrap a piece of flannel or other cloth around the knob and pull it out with radio pliers or other suitable tool.
- Remove the back plate and holder.

4. Replacing the Fuses

- AC fuse
Remove two screws holding the top cover and back panel, and remove the top cover.
- Speaker fuse
Remove a screw holding the fuse cover and back panel.

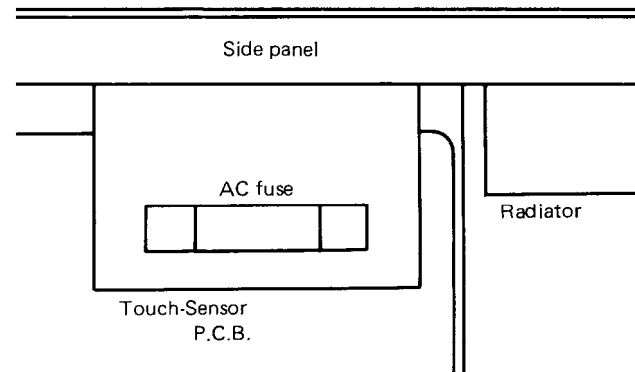

(fig. 2)

Precautions

- For continued protection against fire hazard, replace only with same type and same rating fuse.

		Parts No.	
AC fuse	2A-T	252002	220V model
	4A (ST-6)	252049	120V model
Speaker fuse	4A-T	252014	

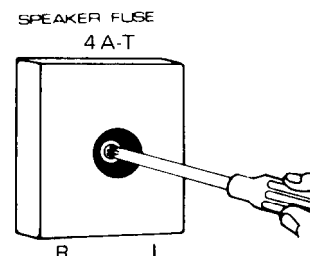

(fig. 3)

5. Touch-sensor Circuit

If the TUNED lamp does not turn off when you touch the tuning knob, this may be due to strong signals generated by a nearby MW or SW broadcasting station. In this case, adjust the frequency of oscillator coil with L301 until the TUNED lamp turn off.

EXPLODED VIEW

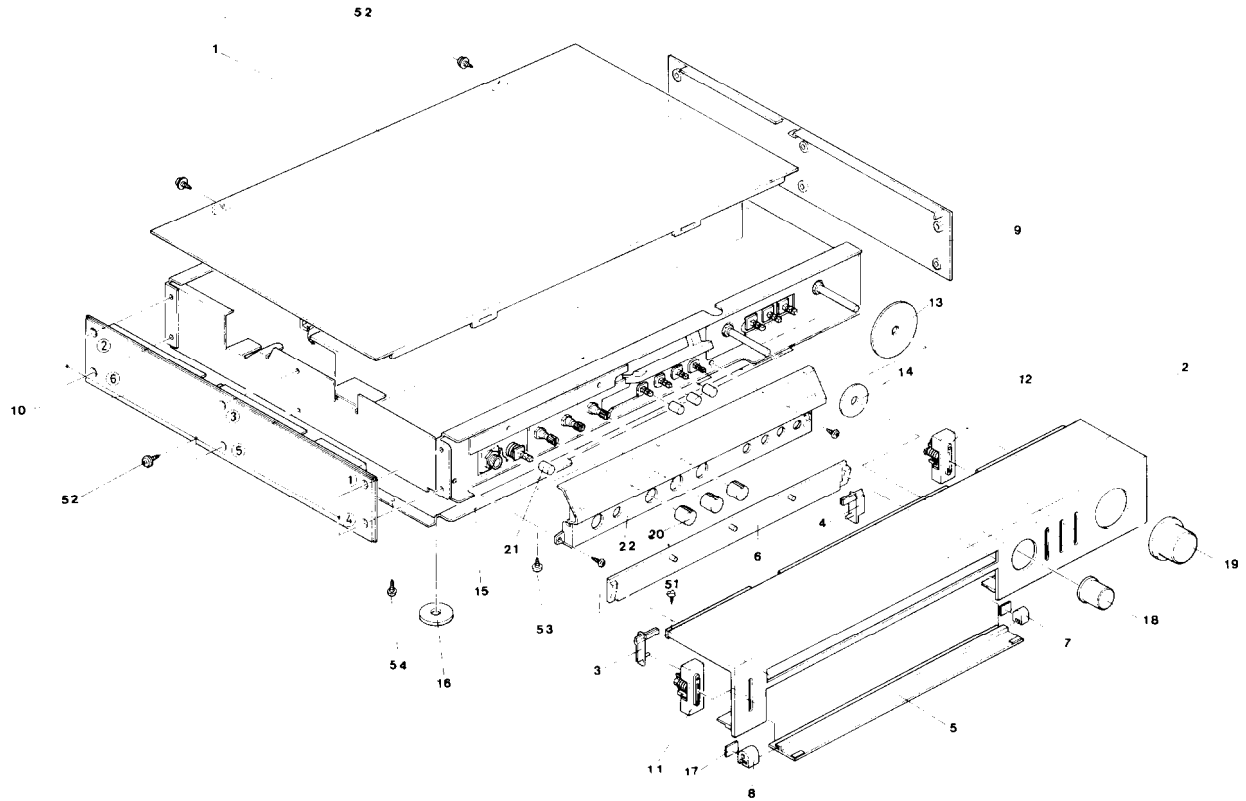

EXPLODED VIEW – PARTS LIST

REF. NO.	PARTS NO.	DESCRIPTION	REF. NO.	PARTS NO.	DESCRIPTION
1	28184058A	Top cover		27267051	Guide
2	27210138	Front panel		27180037	Spring
	13609121	Front panel ass'y		28320341	Knob
3	13918129	Side plate (SL)	13	28140126	Cushion
4	13918128	Side plate (SR)	14	28140127	Cushion
5		Front panel (S) ass'y	15	27170061C	Bottom board
	27210135	Front panel (S)	16	27175015	Leg
	27262050	Magnet plate	17	28140189	Cushion
6	28191041	Dial plate	18	28320339	Tuning knob
7	27300194	Bearing (R)	19	28320338	Volume knob
8	27300195	Bearing (L)	20	28320340	Mode knob
9	28125065	End cap (R)	21	28320343	Push knob
10	28125066	End cap (L)	22	28133018A	Back plate
11	13918125	Power switch knob ass'y		27262047	Plate
	27267050	Guide		27262049A	Plate (dial)
	28198522	Facet	51	834130062	3STS+6BQ, Tapping screw
	27180037	Spring	52	838230082	3STB+8BQ(Ni), Tapping screw
	28320341	Knob	53	838130062	3STB+6BQ, Tapping screw
12	13918126	Push switch knob ass'y	54	831130082	3STW+8BQ, Tapping screw
	28198522	Facet			

BLOCK DIAGRAM

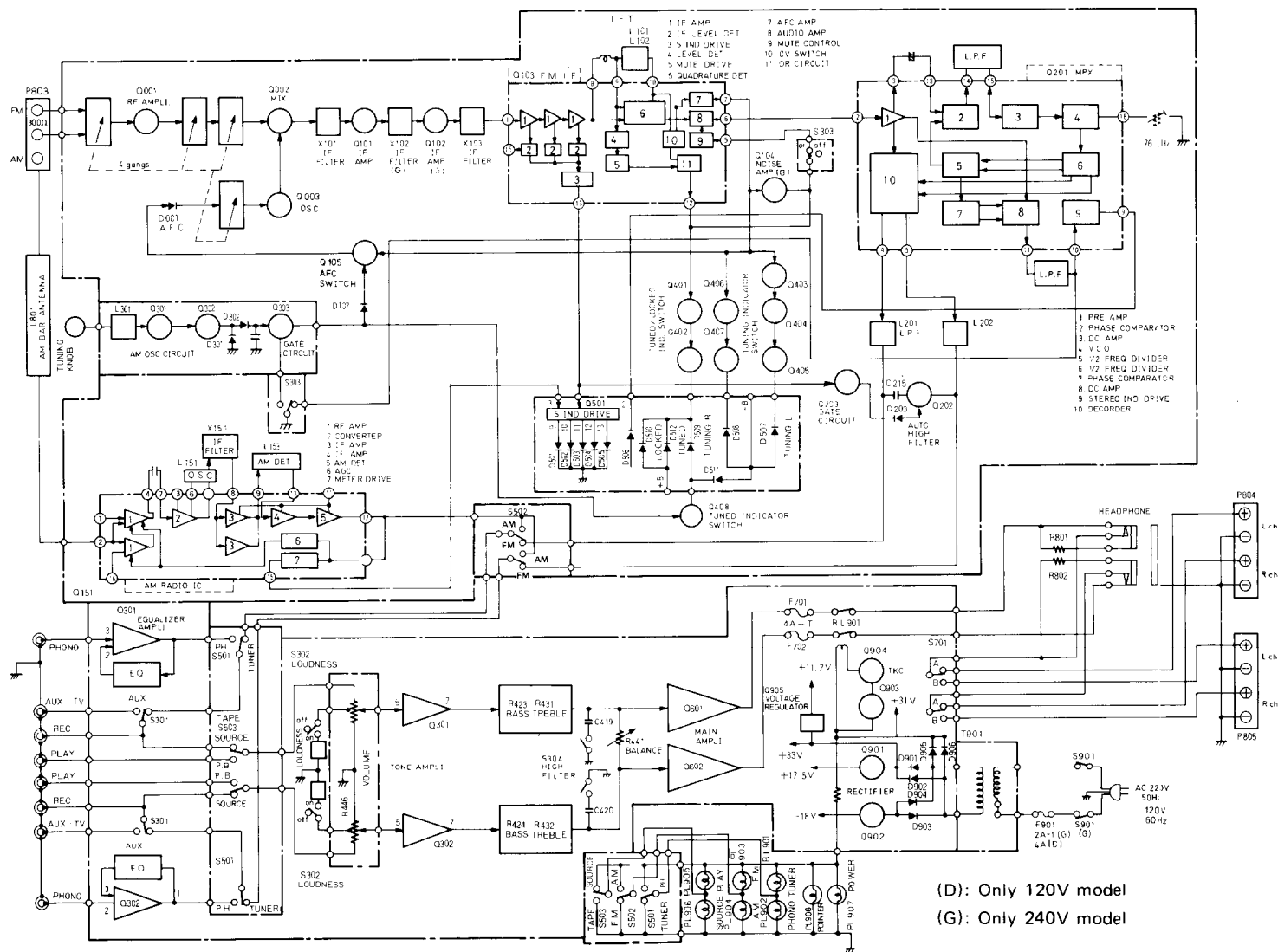

CIRCUIT DESCRIPTION

1. Auto High Blend/Meter Display Circuits

In the Q103 IF system IC, a 3 step IF level detection circuit is built in as illustrated in the block diagram. Its output is pin 13. The relationship between the antenna input and pin 13 is shown in figure 8. This voltage is applied to pin 2 of Q510 lighting up D510–D506 (connected to the output) in response to the antenna input. When the antenna input is within about 45dB, Q203 is cut off so Q202 turns on. C215 is then connected between the left and right channels; high range noise components whose phase is reversed left-right are mixed, and at the expense of high range separation, noise is substantially reduced. At levels below 45dB, Q203 turns on and Q202 is cut off turning off the noise filter.

2. LOCKED/TUNED Indicator Circuits

When a station is tuned from the lower frequencies upward, first, the Q103 AFC output pin 7 (fig. 8) changes as shown in fig. 2, Q406 turns on in the range of A, Q407 also turns on, and D508 lights up. Next, the locked range B is entered whereupon the Q103 pin 12 muting output goes from about 4.1V to 0V. Q401 turns off, Q402 turns on, and the D510, D512 LOCKED L.E.D. comes on and D508 turns off. In this status, when the tuning knob is released, the Q301, L301 oscillation circuit begins oscillating, the signal is amplified by Q302, both waves are rectified by D301 and D302, Q303 turns on, Q408 turns off, and the TUNED L.E.D. lights up. Also, Q105 turns off and the servo lock circuit (AFC circuit) operates. Note that when the C range is entered, Q403 turns on, Q404 and Q405 both turn off and only D507 lights up.

3. Muting Circuit (Only 220V model)

The muting circuit is built in Q103. It detects noise components above 200kHz in the AFC output audio signal, mixes them, activates the muting switch transistor in Q103 and turns off the output (pin 6).

EQUIVALENT CIRCUIT

NJM-4559DX

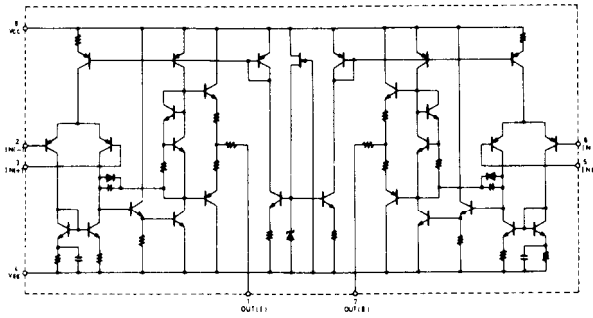

(fig. 6)

LB-1416

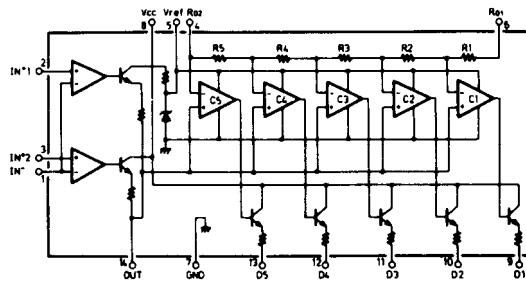

(fig. 7)

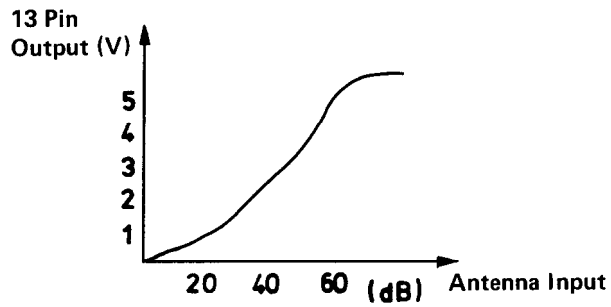

(fig. 8)

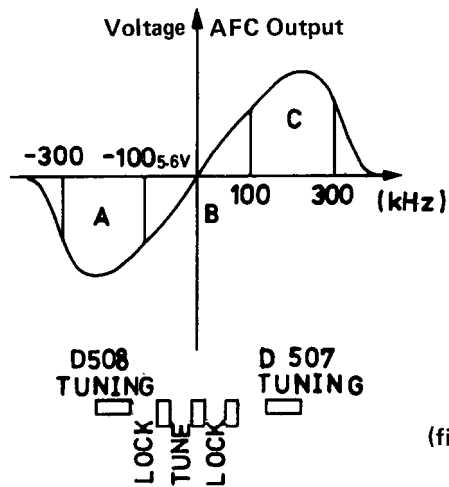

(fig. 9)

COMPONENT LOCATION

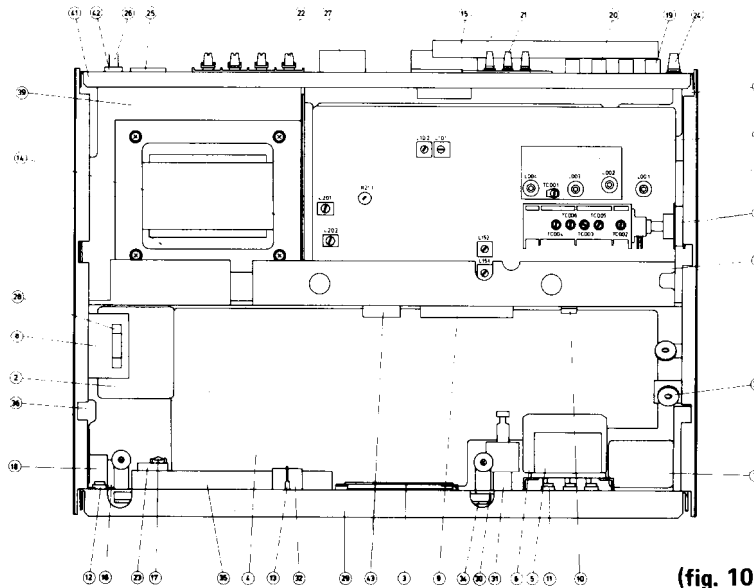

(fig. 10)

COMPONENT LOCATION – PARTS LIST

120V model

REF. NO.	CIRCUIT NO.	PARTS NO.	DESCRIPTION
1	U1	13609571A	NARF-671a, AM/FM tuner p.c.b.
2	U2	13609572A	NAOT-672a, Touch-sensor p.c.b.
3	U3	13918573	NADIS-673, Indicator p.c.b.
4	U4	13609583A	NAAF-683a, Pre./main amplifier p.c.b.
5	U5	13609584A	NASW-684a, Switch p.c.b.
6	U6	13918585	NASW-685, Switch p.c.b.
7	U7	13918586	NAVR-686, Volume control p.c.b.
8	U8	13918587	NAFU-687, Fuse p.c.b.
9	Q601,Q602	222020	STK-463, Power ampli. IC
10	Q905	222549	FS-7812, Regulator IC
11	PL901-PL906	210061	PL12V30mA W-0.6, Pilot lamp
12	PL907	210051	PL12V30mA W-1.5, Pilot lamp
13	PL908	210062	PL12V30mA W-1.8, Pilot lamp
14	T901	230311	NPT-676D, Power transformer
15	L801	232066	NMA-3012, AM bar antenna
16	C901	3504012	UL92-125V103M, UL capacitor
17	R801,R802	441622714	270Ω, 1W, Metal oxide film resistor
18	S901	25035047	NPS-111-L12P, Power switch
19	P801	25045025	NPJ-4PRBL03, Phono/Aux. input terminal
20	P802	25045028	NPJ-4PRBL06, Tape input/output terminal
21	P803	25060020	NTM-3WPUN1, Antenna terminal
22	P804,P805	25060038	NTM-4PRMN09, Speaker terminal
23	P806	250004	HJ-628-H5, Headphone jack
24	P807	25060008	Ground terminal
25		25050032	SI-6444-01, AC outlet
26		253099A	AS-UC-3, Power supply cord
27	F701,F702	252014	4A-T, Speaker protection fuse
	F701a	25050004	Holder for fuse
28	F901	252049	4A(ST-6), Power fuse
29	A001	27110088	Front bracket
30	A003	28175022A	Empire plate
31	A004	27205019A	Drive shaft
32	A005	28165049C	Pointer ass'y
33	A006	27185002A	DP-16, Dial pulley
34	A007	27190048A	Holder
35	A011	27130158	Pointer rail
36	A029	27115047A	Side bracket
37	A030	27115048A	Side bracket
38	A034	27160056A	Radiator
39	A035	27130157B	Bracket for power transformer
40	A036	27200021A	Dial drum
		27180044	Spring for dial drum
		273903	Stringing
41		27120175	Back panel
42		270025	SR-3P-4, Strainrelief

COMPONENT LOCATION – PARTS LIST

220V model

REF. NO.	CIRCUIT NO.	PARTS NO.	DESCRIPTION
1	U1	13609571B	NARF-671b, AM/FM tuner p.c.b.
2	U2	13609572A	NAOT-672a, Touch-sensor p.c.b.
3	U3	13918573	NADIS-673, Indicator p.c.b.
4	U4	13609583A	NAAF-683a, Pre./main amplifier p.c.b.
5	U5	13609584A	NASW-684a, Switch p.c.b.
6	U6	13918585	NASW-685, Switch p.c.b.
7	U7	13918586	NAVR-686, Volume control p.c.b.
8	U8	13918587A	NAFU-687a, Fuse p.c.b.
9	Q601,Q602	222020	STK-463, Power ampli. IC
10	Q905	222549	FS-7812, Regulator IC
11	PL901-PL906	210061	PL12V30mA W-0.6, Pilot lamp
12	PL907	210051	PL12V30mA W-1.5, Pilot lamp
13	PL908	210062	PL12V30mA W-1.8, Pilot lamp
14	T901	230312	NPT-676G Power transformer
15	L801	232066	NMA-3012, AM bar antenna
16	C901,C902	3500052	PME271Y510CEE, IS capacitor
17	R801,R802	441622714	270Ω, 1W, Metal oxide film resistor
18	S901	25035034	NPS-121-L, Power switch
19	P801	25045025	NPJ-4PRBL03, Phono/Aux. input terminal
20	P802	25045028	NPJ-4PRBL06, Tape input/output terminal
21	P803	25060020	NTM-3WPUN1, Antenna terminal
22	P804,P805	25060038	NTM-4PRMN09, Speaker terminal
23	P806	250004	HJ-628-H5, Headphone jack
24	P807	25060008	Ground terminal
25		25050032	SI-6444-01, AC outlet
26		253088	AS-VDE-1, Power supply cord
27	F701,F702	252014	4A-T, Speaker protection fuse
	F701a	25050004	Holder for fuse
28	F901	252002	2A-T, Power fuse
29	A001	27110088	Front bracket
30	A003	28175022A	Empire plate
31	A004	27205019A	Drive shaft
32	A005	28165049C	Pointer ass'y
33	A006	27185002A	DP-16, Dial pulley
34	A007	27190048A	Holder
35	A011	27130158	Pointer rail
36	A029	27115047A	Side bracket
37	A030	27115048A	Side bracket
38	A034	27160056A	Radiator
39	A035	27130157B	Bracket for power transformer
40	A036	27200021A	Dial drum
		27180044	Spring for dial drum
		273903	Stringing
41		27120176	Back panel
42		25065018	SR-3P-4, Strainrelief

ALIGNMENT PROCEDURES

INSTRUMENTS REQUIRED

1. AM and FM Signal Generator
2. Vacume Tube Voltage Meter (VTVM) AC, DC
3. Oscilloscope
4. Distortion Analyzer
5. Stereo Modulator
6. Frequency Counter

GENERAL ALIGNMENT CONDITIONS

1. Signal input should be kept as low as possible.
2. Standard modulation is 400Hz 30% (AM), 1 kHz 100% (FM MONO) pilot 9% sub and main 91% (FM STEREO).
3. Standard knob position
 SPEAKERS A
 BASS, TREBLE & BALANCE..... Center
 HI-FILTER, LOUDNESS,
 MUTING LOCK OFF
 TAPE OFF (source)

(1) FM FRONT END ALIGNMENT

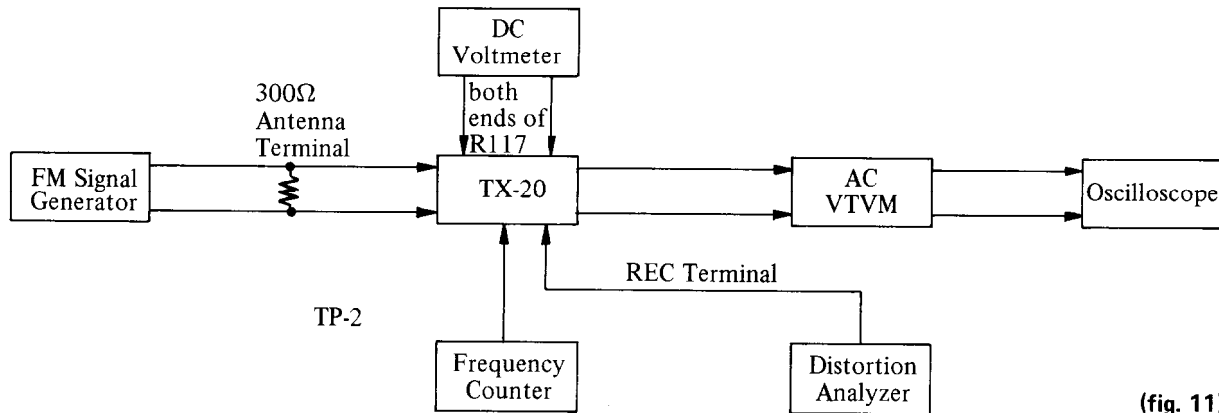

(fig. 11)

Step	FM Signal Generator	Dial to set	Adjust	Output Indicator	Adjust for	Remarks
1	No signal	Quiet Point	L101	DC Voltmeter	0V	Repeat Steps 1 and 2 as necessary
2	98MHz 65dBf(60dB) 1kHz 75kHz devi.	98MHz	L102	Distortion Analyzer	Minimum	
3	90MHz 65dBf(60dB) 1kHz 75kHz devi.	90MHz	L004	DC Voltmeter	0V	Repeat Steps 3 and 4 as necessary
4	106MHz 65dBf(60dB) 1kHz 75kHz devi.	106MHz	TC001			
5	90MHz 20dBf(15dB) 1kHz 75kHz devi.	90MHz	L001 L003	AC VTVM or Oscilloscope	Maximum	Repeat Steps 5 and 6 as necessary
6	106MHz 20dBf(15dB) 1kHz 75kHz devi.	106MHz	TC002 TC004		Maximum	
7	98MHz 65dBf(60dB) no mod.	98MHz	R212 ^{or} R213	Frequency Counter	76kHz	

(2) AM RF ALIGNMENT

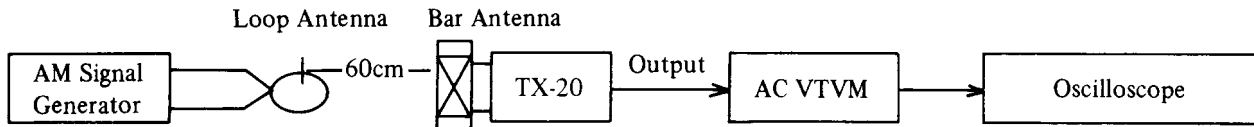

Step	Set Signal	Set Radio Dial	Adjust	VTVM reading	Remarks
1	515 kHz 400 Hz 30 %	Lower end (515 kHz)	L151	Maximum	Repeat steps 1 and 2 as necessary
2	1680 kHz 400 Hz 30%	Upper end (1680 kHz)	TC006	Maximum	
3	600 kHz 400 Hz 30%	600 kHz	L801	Maximum	Adjust with L105 when Repeat steps 3 and 4 as necessary
4	1400 kHz 400 Hz 30 %	1400 kHz	TC005	Maximum	

STRINGING DIAGRAM

1. Close the variable capacitor complete and tie the dial cord to the spring of the drum.
2. Thread the dial cord in the direction of arrow from ① to ④ and wind the dial cord three turns around the tuning shaft clockwise.
3. Wind the dial cord 1½ turns around the dial drum.
4. Thread the dial cord to the dial pulley 4.

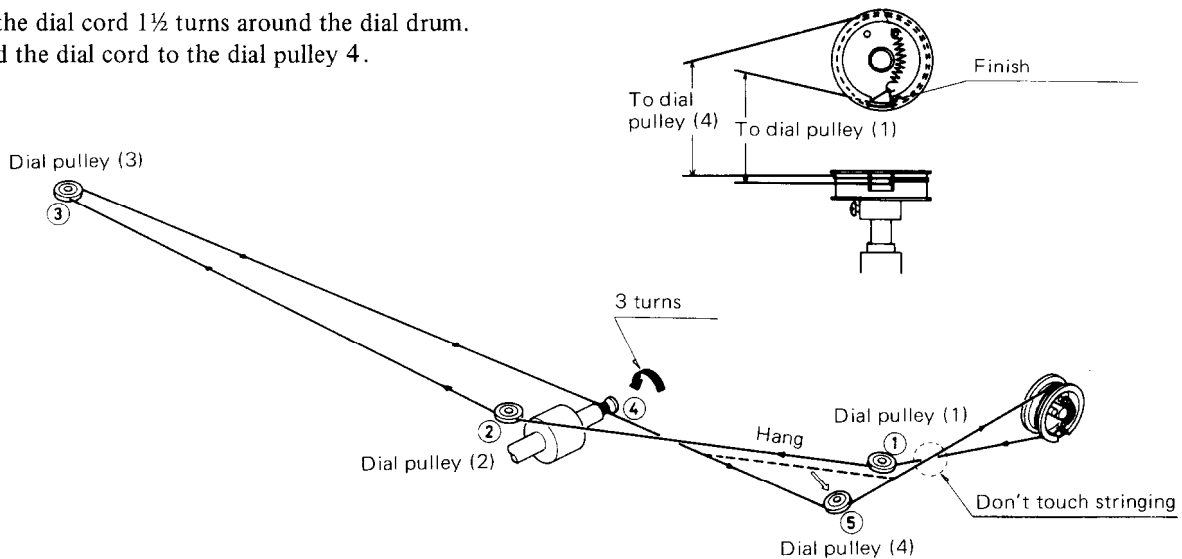

TOUCH-SENSOR PC BOARD (NAOT-672a) – PARTS LIST

CIRCUIT NO.	PARTS NO.	DESCRIPTION
Q301, Q302 Q303	Transistors	
	2211623	2SC941(TM)(O)
	2211255	2SC1815(GR)
PL301	211002	Neon lamp NE-2HW
D301, D302 D304	Diodes	
	223103 223105	1N60 1S1555
L301	232042	Coil NMO-2504
C306	352741001	Capacitor 10μF, 16V, Elect.

INDICATOR PC BOARD (NADIS-673) – PARTS LIST

CIRCUIT NO.	PARTS NO.	DESCRIPTION
Q501	IC	
	222541	LB1426
D501–D505 D506–D508 D509 D510, D512 D511	L.E.Ds	
	225035	LN324GP
	225034	LN224RP
	225035	LN324GP
	225034	LN224RP
	223105	1S1555
C501 C502, C503	Capacitors	
	352741001	10μF, 16V, Elect.
	352750471	4.7μF, 25V, Elect.

AM/FM TUNER PC BOARD (NARF-671b) – PARTS LIST

CIRCUIT NO.	PARTS NO.	DESCRIPTION
	ICs	
Q103	222421	HA-1137W
Q151	222497	LA-1240
Q201	222453	HA-1196
	Transistors	
Q001, Q002	2211713	3SK73(GR), F.E.T.
Q003, Q101, Q102	2211722	2SC1923(R)
Q104, Q105, Q203, Q401–Q403, Q405, Q407, Q408	2211255	2SC1815 (GR)
Q202	2211293	2SK68(M), F.E.T.
Q404, Q406	2211454	2SA1015(Y)
	Diodes	
D001	233110	1S2687F
D101, D104–D107, D109, D111, D113, D151, D201, D203	223105	1S1555
D102, D103	223103	1N60
D108, D110	223106	1S1554
D152	4000022	VD-1212
	Coils	
L001	233088-1 or 2330106	NFA-3001 or NFA-3009, Antenna
L002	233178	NFRF-3015, RF
L003	233093	NFRF-3004, RF
L004	233180	NFO-3014, Oscillator
L103	233031	NMC-9-1, 2.2mH, MPX
L151	232073	NMO-2008, AM oscillator
L201, L202	233181	NMC-5018
	Transformers	
L101	233148	NFIF-6010P
L102	233149	NFIF-6010S
L152	232077	NMIF-6009
L153	232041	NIT-0509
	Ceramic filters	
X101–X103	3010035	SFE-10.7MM
X151	3010034	SFZ-455A
	Capacitors	
VC001	3050006	NVC20FQ327WD02, Variable
TC001	3060003	NTC-10P02, Trimmer
C105, C107	352741001	10 μ F, 16V, Elect.
C112	352780331	3.3 μ F, 50V, Elect.
C114	352784791	0.47 μ F, 50V, Elect.
C117	352780101	1 μ F, 50V, Elect.
C122	352742201	22 μ F, 16V, Elect.
C123	352741001	10 μ F, 16V, Elect.
C124–C126	352780101	1 μ F, 50V, Elect.
C128	352780221	2.2 μ F, 50V, Elect.
C156	372323614	360pF \pm 5%, 50V, ST
C159	352741001	10 μ F, 16V, Elect.
C162	352780471	4.7 μ F, 50V, Elect.
C165	352780331	3.3 μ F, 50V, Elect.
C166	352721011	100 μ F, 6.3V, Elect.
C169	352744701	47 μ F, 16V, Elect.
C201	352750471	4.7 μ F, 25V, Elect.
C204, C205	352741001	10 μ F, 16V, Elect.
C208	352780221	2.2 μ F, 50V, Elect.
C209	352784791	0.47 μ F, 50V, Elect.
C210	352780331	3.3 μ F, 50V, Elect.
C211	372325114	510pF \pm 5%, 50V, ST
C212, C213	352780101	1 μ F, 50V, Elect.
C214	352744711	470 μ F, 16V, Elect.
	Resistors	
R213	5225015	N10HR10KBD, Semi-fixed

PRE., AND MAIN AMPLIFIER PC BOARD (NAAF-683a) – PARTS LIST

CIRCUIT NO.	PARTS NO.	DESCRIPTION
	ICs	
Q301, Q302	222534	MJM-4559DX
Q401, Q402	222020	STK-463
Q601, Q602	222549	FS-7812
Q905		
	Transistors	
Q901, Q904	2211254	2SC1815 (Y)
Q902	2211454	2SA1015 (Y)
Q903	2211255	2SC1815(GR)
	Diodes	
D901–D904	223845	GP-20D
D905, D906, D908	223848	GP-08B
D907	223106	1S1554
D910	224089	BZ-110
	Coil	
L601, L602	231001	S-1.3B
	Capacitors	
C301, C302	352780101	1 μ F, 50V, Elect.
C307, C308	352734701	47 μ F, 10V, Elect.
C313, C314	392884797	0.47 μ F, 50V, LL
C405, C406	392884797	0.47 μ F, 50V, LL
C407, C488	352780101	1 μ F, 50V, Elect.
C409, C410	352742201	22 μ F, 16V, Elect.
C601, C602	352750471	4.7 μ F, 25V, Elect.
C607, C608	352734701	47 μ F, 10V, Elect.
C609, C610	352784701	47 μ F, 50V, Elect.
C908	352782211	220 μ F, 50V, Elect.
C909, C910	3504124	6,800 μ F, 40V, Elect.
C911, C912	352784701	47 μ F, 50V, Elect.
C915, C916	352752211	220 μ F, 25V, Elect.
C918	352741011	100 μ F, 16V, Elect.
C919	352782201	22 μ F, 50V, Elect.
C920	352743301	33 μ F, 16V, Elect.
C923–C925	352781001	10 μ F, 50V, Elect.
C929	352781011	100 μ F, 50V, Elect.
C930	352741001	10 μ F, 16V, Elect.
	Resistors	
R423, R424	5148036	N16RGL250KC15, Bass control variable
R431, R432	5148036	N16RGL250KC15, Treble control variable
R441	5104086	N16RL50KWTP15, Balance control variable
R605, R606	441521024	1k Ω , 1/2W, Metal oxide film
R607, R608	441523324	3.3k Ω , 1/2W, Metal oxide film
R611, R612	451633394	0.33 Ω , 1W, Metal
R613, R614	451530474	4.7 Ω , 1/2W, Metal
R615, R616	451530684	6.8 Ω , 1/2W, Metal
R905	48114704	47 Ω , 5W, Cement
R906	48151114	110 Ω , 7W, Cement
R911	441521014	100 Ω , 1/2W, Metal oxide film
R915	441623314	330 Ω , 1W, Metal oxide film
	Switches	
S301–S304	25035134	NPS-422-L99
	25035125	NPS-122-L90
	Relay	
RL901	25065052	NRL-2P-5A-DC24-04
	Plate	
	27300130	
	Thermo switch	
S903	25065091	1P-105A-95

SWITCH PC BOARD (NASW-684a) – PARTS LIST

CIRCUIT NO.	PARTS NO.	DESCRIPTION
S501–S503	25035127	NPS-342-L92

VOLUME CONTROL PC BOARD (NAVR-686) – PARTS LIST

CIRCUIT NO.	PARTS NO.	DESCRIPTION
R445, R446	5172045	N24RGL41C250KBTP35

SCHEMATIC DIAGRAM
MODEL TX-20 120V model

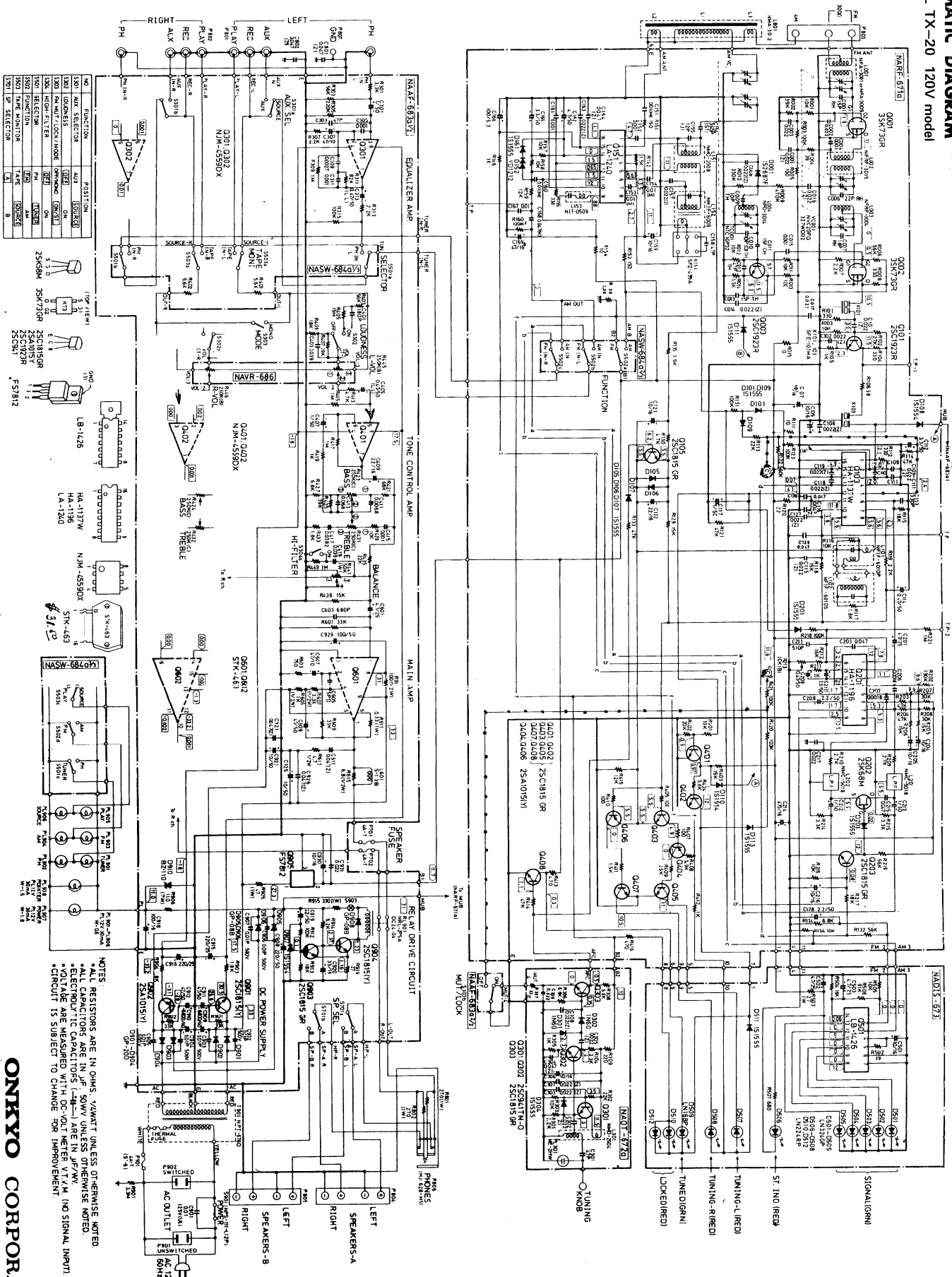

SCHEMATIC DIAGRAM
MODEL TX-20 220V model

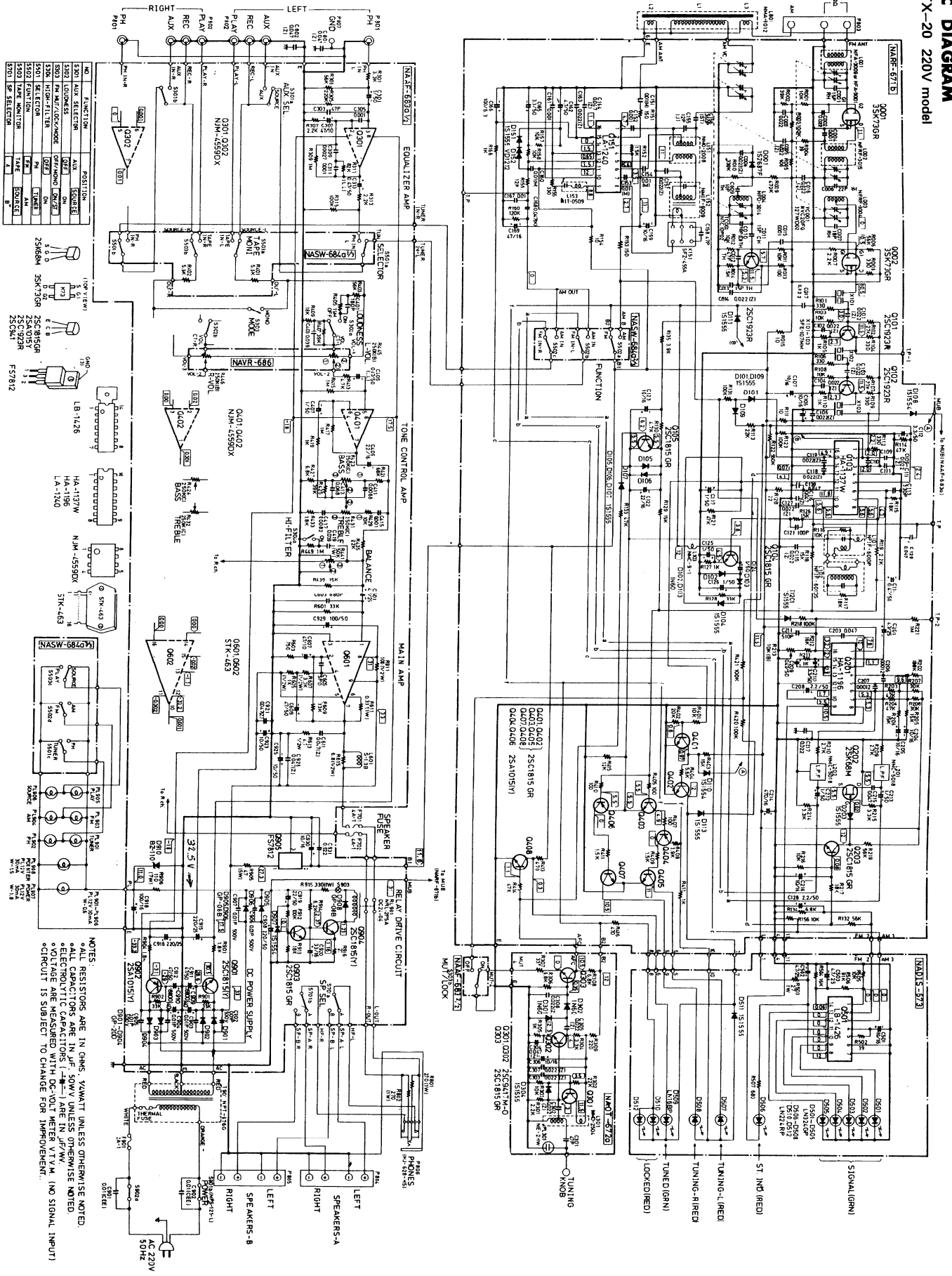

NO.	FUNCTION	POSITION
3001	AUX. SELECTION	ON/OFF
3002	LOUDNESS	ON/OFF
3003	FM A/T/LOC/MODE	ON/OFF
3004	HIGH-FILTER	ON/OFF
3005	TUNING	TUNER
3006	TAPE MONITOR	TAPE
3007	SELECTION	ON/OFF

NOTES:
 ALL RESISTORS ARE IN OHMS, UNLESS OTHERWISE NOTED.
 ALL CAPACITORS ARE IN P.F., UNLESS OTHERWISE NOTED.
 ELECTROLYTIC CAPACITORS (ELECT.) ARE IN MICROFARADS.
 VOLTAGE ARE MEASURED WITH DC-VOLT METER V.T.M. (NO SIGNAL INPUT)
 CIRCUIT IS SUBJECT TO CHANGE FOR IMPROVEMENT.

ONKYO CORPORATION

PRINTED CIRCUIT BOARD-PARTS LIST

AM/FM TUNER PC BOARD (NARF-671a) – PARTS LIST

CIRCUIT NO.	PARTS NO.	DESCRIPTION
	ICs	
Q103	222421	HA-1137W
Q151	222497	LA-1240
Q201	222453	HA-1196
	Transistors	
Q001, Q002	2211713	3SK73(GR), F.E.T.
Q003, Q101	2211722	2SC1923(R)
Q105, Q203, Q401–Q403, Q405, Q407, Q408	2211255	2SC1815(GR)
Q202	2211293	2SK68(M), F.E.T.
Q404, Q406	2211454	2SA1015(Y)
	Diodes	
D001	233110	1S2687F
D101, D105–D107, D109, D111, D113, D151, D201, D203 D108, D110 D152	223105	1S1555
	223106	1S1554
	4000022	VD-1212
	Coils	
L001	233088-1 or 233106	NFA-3001 or NFA-3009, Antenna
L002	233178	NFRF-3015, RF
L003	233093	NFRF-3004, RF
L004	233180	NFO-3014, Oscillator
L151	232073	NMO-2008, AM oscillator
L201, L202	233181	NMC-5018
	Transformers	
L101	233148	NFIF-6010P
L102	233149	NFIF-6010S
L152	232077	NMIF-6009
L153	232041	NIT-0509
	Ceramic filters	
X101, X103	3010003	SFE-10.7MA
X151	3010034	SFZ-455A
	Capacitors	
VC001	3050006	NVC20FQ327WD02, Variable
TC001	3060003	NTC-10P02, Trimmer
C105, C107	352741001	10 μ F, 16V, Elect.
C112	352780331	3.3 μ F, 50V, Elect.
C114	352784791	0.47 μ F, 50V, Elect.
C117	352780101	1 μ F, 50V, Elect.
C122	352742201	22 μ F, 16V, Elect.
C123	352741001	10 μ F, 16V, Elect.
C128	352780221	2.2 μ F, 50V, Elect.
C156	372323614	360pF \pm 5%, 50V, ST
C159	352741001	10 μ F, 16V, Elect.
C162	352780471	4.7 μ F, 50V, Elect.
C165	352780331	3.3 μ F, 50V, Elect.
C166	352721011	100 μ F, 6.3V, Elect.
C169	352744701	47 μ F, 16V, Elect.
C201	352750471	4.7 μ F, 25V, Elect.
C204, C205	352741001	10 μ F, 16V, Elect.
C208	352780221	2.2 μ F, 50V, Elect.
C209	352784791	0.47 μ F, 50V, Elect.
C210	352780331	3.3 μ F, 50V, Elect.
C211	372325114	510pF \pm 5%, 50V, ST
C212, C213	352780101	1 μ F, 50V, Elect.
C214	352744711	470 μ F, 16V, Elect.
	Resistor	
R213	5225015	N10HR10KBD, Semi-fixed

PRE., AND MAIN AMPLIFIER PC BOARD (NAAF-683a) – PARTS LIST

CIRCUIT NO.	PARTS NO.	DESCRIPTION
	ICs	
Q301, Q302, Q401, Q402, Q601, Q602 Q905	222534	NJM-4559DX
	222020	STK-463
	222549	FS-7812
	Transistors	
Q901, Q904	2211254	2SC1815(Y)
Q902	2211454	2SA1015(Y)
Q903	2211255	2SC1815(GR)
	Diodes	
D901–D904	223845	GP-20D
D905, D906, D908	223848	GP-08B
D907	223106	1S1554
D910	224089	BZ-110
	Coil	
L601, L602	231001	S-1.3B
	Capacitors	
C301, C302	352780101	1 μ F, 50V, Elect.
C307, C308	352734701	47 μ F, 10V, Elect.
C313, C314	392884797	0.47 μ F, 50V, LL
C405, C406	392884797	0.47 μ F, 50V, LL
C407, C408	352780101	1 μ F, 50V, Elect.
C409, C410	352742201	22 μ F, 16V, Elect.
C601, C602	352750471	4.7 μ F, 25V, Elect.
C607, C608	352734701	47 μ F, 10V, Elect.
C609, C610	352784701	47 μ F, 50V, Elect.
C908	352782211	220 μ F, 50V, Elect.
C909, C910	3504124	6,800 μ F, 40V, Elect.
C911, C912	352784701	47 μ F, 50V, Elect.
C915, C916	352752211	220 μ F, 25V, Elect.
C918	352741011	100 μ F, 16V, Elect.
C919	352782201	22 μ F, 50V, Elect.
C920	352743301	33 μ F, 16V, Elect.
C923–C925	352781001	10 μ F, 50V, Elect.
C929	352781011	100 μ F, 50V, Elect.
C930	352741001	10 μ F, 16V, Elect.
	Resistors	
R423, R424	5148036	N16RGL250KC15, Bass control variable
R431, R432	5148036	N16RGL250KC15, Treble control variable
R441	5104086	N16RL50KWTP15, Balance control variable
R605, R606	441521024	1k Ω , 1/2W, Metal oxide film
R607, R708	441523324	3.3k Ω , 1/2W, Metal oxide film
R611, R612	451633394	0.33 Ω , 1W, Metal
R613, R614	451530474	4.7 Ω , 1/2W, Metal
R615, R616	451530684	6.8 Ω , 1/2W, Metal
R905	48114704	47 Ω , 5W, Cement
R906	48151114	110 Ω , 7W, Cement
R911	441521014	100 Ω , 1/2W, Metal oxide film
R915	441623314	330 Ω , 1W, Metal oxide film
	Switches	
S301–S304	25035134	NPS-422-L99
	25035125	NPS-122-L90
	Relay	
RL901	25065052	NRL-2P-5A-DC24-04
	Plate	
	27300130	
	Thermo switch	
S903	25065091	1P-105A-95

PACKING PROCEDURES

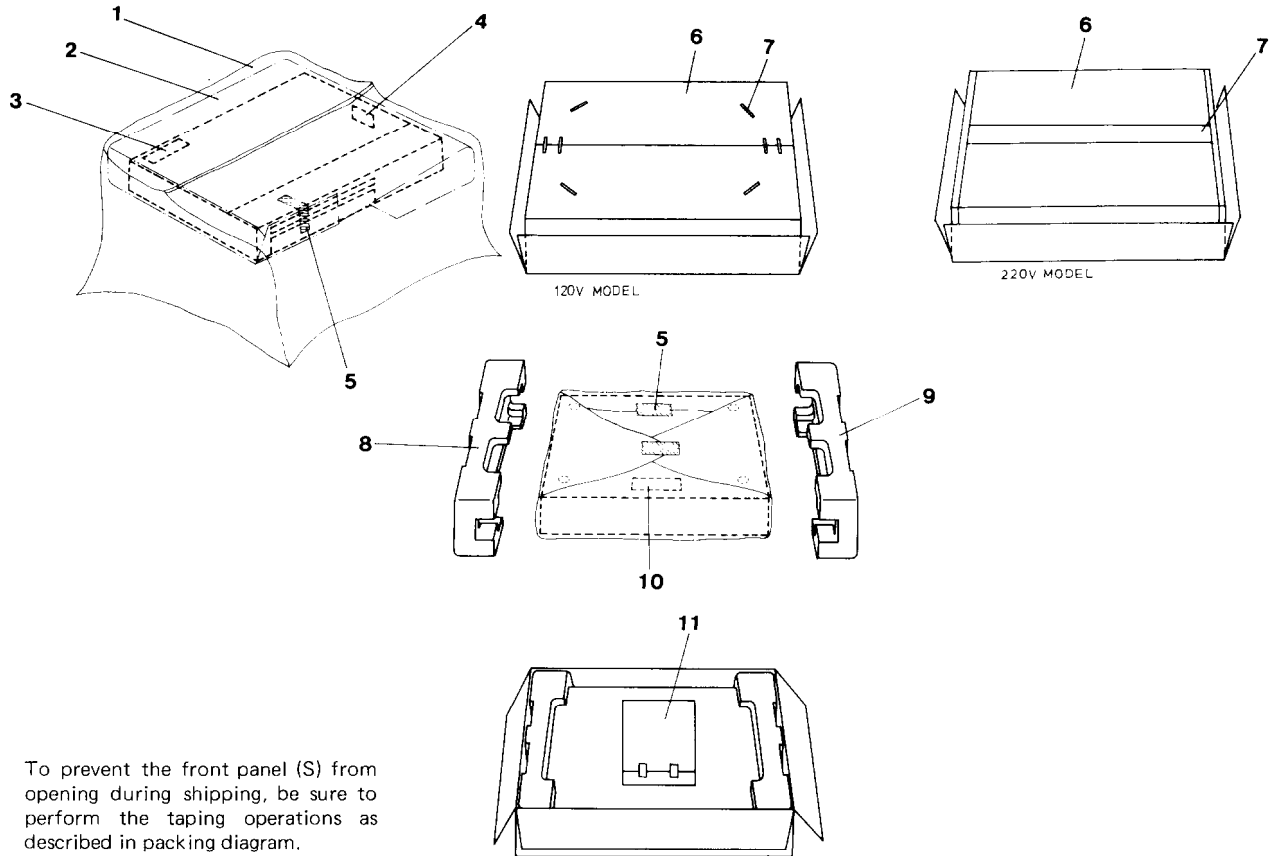

To prevent the front panel (S) from opening during shipping, be sure to perform the taping operations as described in packing diagram.

PACKING PROCEDURES – PARTS LIST 120V model

REF. NO.	PARTS NO.	DESCRIPTION
1	29100033	650 × 750mm, Poly bag
2	29095064	900 × 400mm, Protection sheet
3	29360295	Label for heatsink
4	282969	Caution label A (USA)
5	261504	Tape
6	29050292A	Carton box
7	282301	Sealing hook
8	29090404A	Pad (R)
9	29090403A	Pad (L)
10	293041	Caution label (USA)
11	13609119	Accessory bag complete
	29365006	Warranty card (USA)
	29358002	Service station list (USA)
	252049	4A-T(ST-6), Fuse
	292064	FM antenna
	29340357	Instruction manual
	29100006	350 × 250mm, Poly bag
	29100002	150 × 80mm, Poly bag

(USA) : Only U.S.A. model

PACKING PROCEDURES – PARTS LIST 220V model

REF. NO.	PARTS NO.	DESCRIPTION
1	29100033	650 × 750mm, Poly bag
2	29095064	900 × 400mm, Protection sheet
3	29360317	Label for heatsink
5	261504	Tape
6	29050292A	Carton box
7	260012	Tape
8	29090404A	Pad (R)
9	29090403A	Pad (L)
11	13609119	Accessory bag complete
	29365005-2	Warranty card (G)
	252002	2A-T, Fuse
	292064	FM antenna
	29340358	Instruction manual
	29100006	350 × 250mm, Poly bag
	29100002	150 × 80mm, Poly bag

(G) : Only Germany model

ONKYO CORPORATION

International Division: No. 24 Mori Bldg., 23-5, 3-chome, Nishi-Shinbashi, Minato-ku, Tokyo, Japan
Telex: 2423551 ONKYO J. Phone: 03-432-6981

ONKYO U.S.A. CORPORATION

Eastern Office
42-07 20th Avenue, Long Island City, New York 11105, U.S.A. Phone: (212) 728-4639
Midwest Office
935 Sivert Drive, Wooddale, Illinois 60191, U.S.A. Phone: (312) 595-2970

ONKYO DEUTSCHLAND GMBH, ELECTRONICS

8034 München-Germering, Industriestrasse 18, West Germany. Telex: 521726 Telefon: (089)-84-5041