

# ONKYO SERVICE MANUAL

## SERVO LOCKED FM/AM STEREO RECEIVER MODEL TX-2000

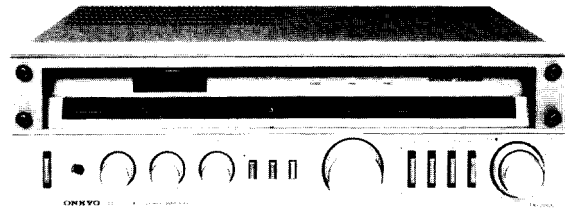

D model



G/W model

### TABLE OF CONTENTS

Item	Page
Specifications	2
Component location	3
Exploded view	4
Exploded view-parts list	4
Disassembly	5
Service procedures	5
Precautions	5
Block diagram	6
Printed circuit board-parts list (G model)	8
Alignment procedures	9
Stringing diagram	10
Printed circuit board view (G model)	11
Schematic diagram (G model)	13
Printed circuit board view (W model)	15
Schematic diagram (W model)	17
Printed circuit board view (D model)	19
Schematic diagram (D model)	21
Printed circuit board-parts list (D model)	23
Packing procedures	24

**ONKYO**  
**AUDIO COMPONENTS**

## SPECIFICATIONS

### AMPLIFIER SECTION

Output Power:	27 watts per channel, min. RMS, at 8 ohms both channels driven, from 20 Hz to 20,000 Hz, with no more than 0.06% total harmonic distortion. 30W + 30W (8Ω, 1kHz, 0.06% T.H.D.)
Dynamic:	75 watts total at 8 ohms 0.06% T.H.D.
Total Harmonic Distortion:	0.06% at rated power 0.05% at 1 watt output
IM Distortion:	0.1% at rated power 0.05% at 1 watt output
Damping Factor:	35 at 8 ohms
Frequency Response:	20 Hz — 30,000 Hz (±1dB)
RIAA Deviation:	20 Hz — 20,000 Hz (±0.8dB)
Sensitivity & Impedance:	Phono : 2.5 mV, 50 kohms Tape Play : 150 mV, 50 kohms Tape Rec : 150 mV, 3.5 kohms (PH) DIN PLAY : 150 mV, 50 kohms DIN REC : 30 mV, 50 kohms
Phono Overload:	110 mV R.M.S. at 1 kHz, 0.06% T.H.D.
Signal-to-Noise Ratio:	Phono: 85 dB (at 10 mV input A weighted) 75 dB (at 5 mV input, 1 watt output, IHF A weighted) Tape: 95 dB (A weighted) 80 dB (at 0.5 V input, 1 watt output, IHF A weighted)
Tone Controls:	Bass: ±12 dB at 100 Hz Treble: ±12 dB at 10 kHz
Loudness (−30 dB):	+9 dB at 40 Hz +5 dB at 20 kHz

### TUNER SECTION

#### FM :

Tuning Range :	87.5 — 108 MHz
Usable Sensitivity :	Mono : 2.2 μV (12.0 dBf) IHF 1.8 μV (S/N 26 dB, 40 kHz Devi.) DIN Stereo : 5 μV (19.2 dBf) IHF 50 μV (S/N 46 dB, 40 kHz Devi.) DIN

#### 50 dB Quieting

Sensitivity:	Mono : 4.5 μV (18.3 dBf) IHF Stereo : 50 μV (39.2 dBf) IHF
Capture Ratio :	1.5 dB
Image Rejection Ratio :	45 dB
IF Rejection Ratio :	80 dB

Spurious Rejection Ratio :	80 dB
Signal-to-Noise Ratio:	Mono : 68 dB Stereo : 63 dB
Alternate Channel Att.:	60 dB (IHF)
Selectivity :	42 dB (DIN) (±300 kHz, 40 kHz Devi.)
AM Suppression Ratio :	50 dB
Harmonic Distortion :	Mono : 0.2% Stereo : 0.4%
Frequency Response :	30 Hz — 15,000 Hz (±1.5 dB)
Stereo Separation :	40 dB at 1 kHz 30 dB at 100 Hz — 10,000 Hz
Muting Level :	3 μV (14.7 dBf)
Stereo Threshold :	3 μV (14.7 dBf)
Servo Lock Level :	3 μV (14.7 dBf)

#### AM

Tuning Range :	525 — 1,620 kHz
Usable Sensitivity :	25 μV
Image Rejection Ratio :	45 dB
IF Rejection Ratio :	30 dB
Signal-to-Noise Ratio :	40 dB
Harmonic Distortion :	0.8%

#### GENERAL

Power Supply :	AC 120 V, 60 Hz (D model) AC 220 V, 50 Hz (G model) AC 120 V/220 V, 50 Hz/60 Hz (W model) AC 240 V, 50 Hz (Q model)
Outputs :	Speaker A & B, Phones, Tape Rec Out 1 & 2, AC Outlet (unswitchedx1) (Only D model) DIN Rec Out (Only G/Q model) Phono, Tape Play 1 & 2, FM and AM Antennas DIN Play (Only G/Q model)
Antennas :	FM : 300 ohms balanced and 75 ohms unbalanced AM : built-in ferrite core antenna and external terminal
Semiconductors :	1 FET, 12 transistors, 8 ICs, 22 diodes
Dimensions (W x H x D) :	418 x 131 x 328 mm 16-1/2" x 5-3/16" x 12-15/16"
Weight :	8.1 kg, 17.8 lbs

Specifications and features are subject to change without notice.

# COMPONENT LOCATION

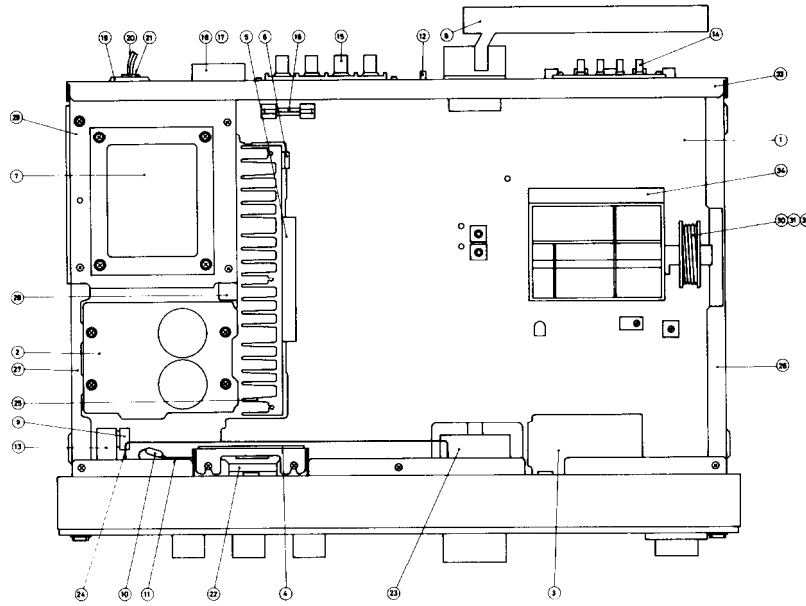

## COMPONENT LOCATION - PARTS LIST

### D/W model

Ref. No.	Circuit No.	Part No.	Description
1	U1	13529562	NAAR-862, Tuner and amplifier pc board (D)
		13530562B	NAAR-862b, Tuner and amplifier pc board (W)
2	U2	13529563	NAPS-863, Rectifier pc board
3	U3	13529564	NASW-864, Switch pc board
4	U5	13529566	NAPL-866, Meter illumination lamp pc board
5	Q501, Q601	222020	STK-463, Power amplifier IC
6	Q901	2201073 or 2201074	2SD880(O) or 2SD880(Y) Voltage regulator transistor
7	T901	230367	NPT-704D, Power transformer (D)
		230369	NPT-704DG Power transformer (W)
8	L801	232066	NMA-3012, AM bar antenna
9	C921	3500054	0.01 $\mu$ F, 125 V, CS capacitor (D)
	C921, C922	3500058	PME265MB510CEE, IS capacitor
10	R801, R802	441623314	330 $\Omega$ , 1 W, Metal oxide film resistor
11	S801	25030150	NRS-144-40Y, Speaker selector switch
12	S802	25065016	NSS-2327, Hum sensor switch
13	S901	25035047	NPS-111L-12P, Power switch (D)
		25035034	NPS-121-L, Power switch(W)
14	P804	25060035	NTM-4PRMC06, Antenna terminal
15	P805, P806	25060038	NTM-4PRMN09, Speaker terminal
16	P807	25050004	Fuseholder
17	F501, F601	252003	3A-T, Speaker protection fuse
18	F903	252048	3A(ST-6), AC fuse (D)
	F904	252002	2A-T, AC fuse (W)
19	P901	25050032	S-I6444-01, AC outlet (D)
20	W901	253099A	AS-UC-3, Power supply cord (D)
		253083	AS-CEE, Power supply cord (W)
21	W901a	270025	SR-3P-4, Strainrelief (D)
		270280	SR-4K-4, Strainrelief (W)
22	M101	243127	MIND-0500S127, Signal strength meter
23	A002	27205021	Drive shaft
24		27300297A	Support for lead wire
25		27160069A	Radiator
26		27115069	Side bracket (R)
27		27115070	Side bracket (L)
28		27130209	Bracket for radiator
29		27130210A	Bracket for power transformer
30		27200019A	Dial drum
31		273803	SP-14A, Spring for stringing
32		273904	150 mm, Stringing
33		27120218	Back panel (D)
		27120220	Back panel (W)
	S902	25065109	NSS-2255P, Voltage selector switch (W)
	S803	250142	NSS-2225, De-emphasis selector switch (W)
	F903	252003	3A-T, AC fuse (W)
	F903a	250143	FF-1S4, Fuseholder (W)

### G/Q model

Ref. No.	Circuit No.	Part No.	Description
1	U1	13532562A	NAAR-862a, Tuner and amplifier pc board
2	U2	13532563A	NAPS-863a, Rectifier pc board
3	U3	13529564	NASW-864, Switch pc board
4	U5	13529566	NAPL-866, Meter illumination lamp pc board
5	Q501, Q601	222020	STK-463, Power amplifier IC
6	Q901	2201073 or 2201074	2SD880(O) or 2SD880(Y) Voltage regulator transistor
7	T901	230368	NPT-704G, Power transformer (G)
		230382	NPT-704Q, Power transformer (Q)
8	L801	232066	NMA-3012, AM bar antenna
9	C921	3500058	PME265MB510CEE, IS capacitor
10	R801, R802	441623314	330 $\Omega$ , 1 W, Metal oxide film resistor
11	S801	25030150	NRS-144-40Y, Speaker selector switch
12	S802	25065016	NSS-2327, Hum sensor switch
13	S901	25035176	NPS-111-L 140, Power switch
14	P804	25060035	NTM-4PRMC06, Antenna terminal
15	P805, P806	25060038	NTM-4PRMN09, Speaker terminal
16	P807	25050004	Fuseholder
17	F501, F601	252003	3A-T, Speaker protection fuse
18	F904	252074	2A-SE-EAK, AC fuse
20	W901	253083	AS-CEE, Power supply cord (G)
	W901	728328	2-0.75BS16 GR Y, Power supply cord (Q)
21	W901a	270280	SR-4K-4, Strainrelief (W)
22	M101	243127	MIND-0500S127, Signal strength meter
23	A002	27205021	Drive shaft
24		27300297A	Support for lead wire
25		27160069A	Radiator
26		27115069	Side bracket (R)
27		27115070	Side bracket (L)
28		27130209	Bracket for radiator
29		27130210A	Bracket for power transformer
30		27200019A	Dial drum
31		273803	SP-14A, Spring for stringing
32		273904	150 mm, Stringing
33		27120219	Back panel

D : 120V model

W : 120/220V model

G : 220V model

Q : 240V model

# EXPLODED VIEW

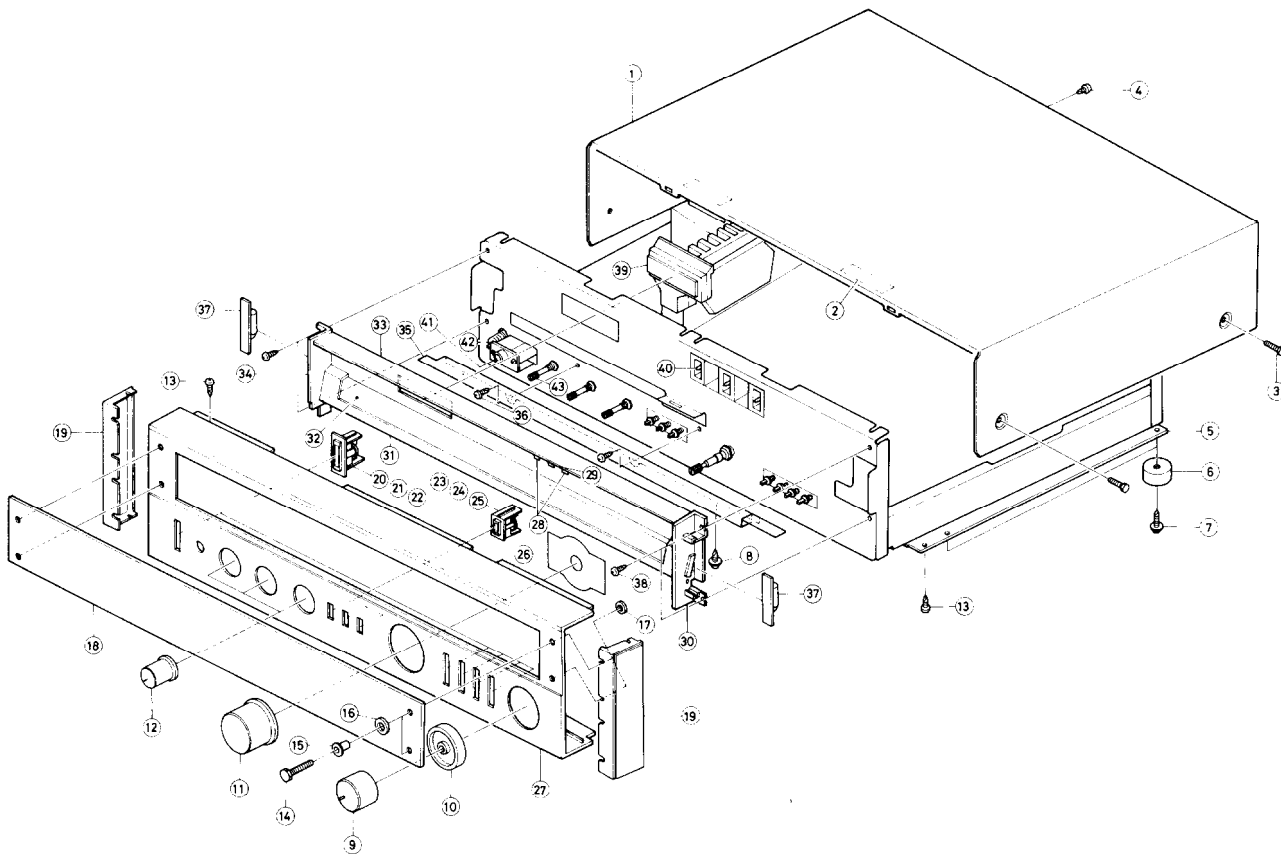

## EXPLODED VIEW – PARTS LIST

Ref. No.	Part No.	Description
1	28184084A	Top cover (D)
	28184085	Top cover (G, W/Q)
2	28140020	4 x 10 x 40 mm, Cushion
3	83844089	4TTB + 8C (BC), Tap screw
4	834430062	3STS + 6BQ (BC), Tapping screw
5	27170077A	Bottom board
6	27175009	Leg
7	831130162	3STW + 16BQ, Tapping screw
8	831130082	3STW + 8BQ, Tapping screw
9	28320433	Knob (VOL)
10	28320431	Knob (BAL)
11	28320408	Knob (TUN)
12	28320397	Knob (TONE)
13	834130062	3STS + 6BQ, Tapping screw
14	84334015	M4 x 15 (Cr), Hexagone bolt
15	27270017A	Spacer
16	870052	10 x 5 x 1.5mm, Washer
17	863140	N-4F-N, Nut
18	28191057	Dial glass
19	28125076A	End cap
20	27267063	Guide for power switch knob
21	27180049	Spring
22	28320398	Power switch knob
23	27267064	Guide for push switch knob
24	27180049	Spring
25	28320399	Push switch knob
	210093	Pointer Lamp
26	28140248A	Cushion
27	13529121	Front panel ass'y
28	28198527	Facet
	261014	Tape (Red)
29	28198527	Facet
	261013	Tape (Green)
30	27250040A	Lamp case (R)
31	27190077	Holder for dial plate
32	28130094	Dial plate
33	28133028	Back plate
34	27250039A	Lamp case (L)
35	27130208	Bracket for dial pointer rail
36	834130062	3STS + 6BQ, Tapping screw
37	13529565	NAPL-865, Dial illumination lamp p.c.b.
38	831130082	3STW + 8BQ, Tapping screw
39	243127	NIND-0500S127, Signal strength meter
40	210083A	PL14VO. 06AW-3, Locked/Tuned/Stereo indicator lamp
41	25045018	LJ-100-J, Stereo headphone jack
42	25035047	NPS-111-L12P, Power switch (D)
	25035176	NPS-111-L140P, (G & Q)
	25035034	NPS-121-L, (W)
43	25030150	NRS-144-40Y, Speaker selector switch
	13549131	Pointer ass'y
	27185006	Dial pulley

## DISASSEMBLY

### Top Cover

Remove the four screws (3) holding the top cover and side bracket.

Remove a screws (4) holding the top cover and back panel.

### Front Panel

Remove the top cover.

Remove the TUNING knob.

Remove the five screws holding the front panel and front bracket.

### Bottom Board

Remove the four screws (8) holding the bottom board and chassis.

Remove the four screws (7) holding the bottom board and legs.

### Meters

Remove the top panel.

Remove the two screws holding the lamp bracket and front bracket.

### Dial Glass

Remove the four screws holding the dial glass and front panel.

Notes: The dial glass has been mounted by applying an 800 gr torque to the screws.

If the dial glass is removed during repairs, and a torque driver is available, apply 800 gr torque to the screws when replacing. If however, a torque driver is not available, simply tighten the screws by hand.

When replacing the dial glass, insert all relevant component parts (14-17) in accordance with the exploded view.

### Pointer Lamp

Remove the top cover and front panel.

Replace the pointer ass'y.

## PRECAUTIONS

For continued protection against fire hazard, replace only with same type and same rating fuse.

### 1. AC fuse

Remove the top cover.

F901, F902 5A-SE-EAK (Parts No. : 252078)  
(Only G/Q model)

F903 3A-(ST-6) (Parts No. : 252048)  
(Only D model)

F904 2A-SE-EAK (Parts No. : 252074)  
(Only G/Q model)

F903 3A-T (Parts No. : 252003)  
(Only W model)

F904 2A-T (Parts No. : 252002)  
(Only W model)

### 2. Speaker fuse

Remove the fuse cover on the back panel with the screwdriver. F501, F601 3A-T (Parts No.: 252003)

## SERVICE PROCEDURES

### 1. Front End

This front end can not be adjusted the FM section. When the front end is replaced, set Tuning dial pointer to zero (0) calibration mark on the logging scale.

### 2. Sensor Switch (SENSOR)

This switch enables the servo lock system for automatic FM tuning to be matched with the various operating conditions. Set it at LOW initially. Switch to NORM or HIGH if the TUNED lamp does not instantly turn off when you touch the tuning knob.

### 3. De-emphasis switch (Only W model)

The 50  $\mu$ sec/75  $\mu$ sec selector switch employed in the W (120/220V) model is located on the bottom board. When shipped from the factory, this switch is set to the 50  $\mu$ sec position. For use in 75  $\mu$ sec regions, switch over to the 75  $\mu$ sec position.

### 4. Voltage Selector (Rear Panel)

Some models are equipped with a voltage selector to conform with local power supplies.

Be sure to set this switch to match the voltage of the power supply in your area before turning the power switch on.

When changing the voltage setting, remove the lock plate covering the switch, then set the voltage to the correct value.

Voltage is changed by sliding the groove in the switch with a screwdriver to the right or left. Confirm that the switch has been moved all the way to the right or left before turning the power switch on.

If there is no voltage selector switch on the unit you have purchased, it can only be used in areas where the power supply voltage is the same as that of the unit.

Voltage Selector Lock Plate

Remove these two screws to take off the voltage selector lock plate.

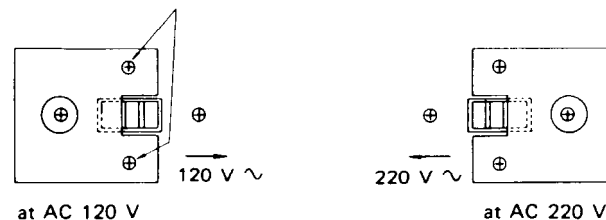

BLOCK DIAGRAM

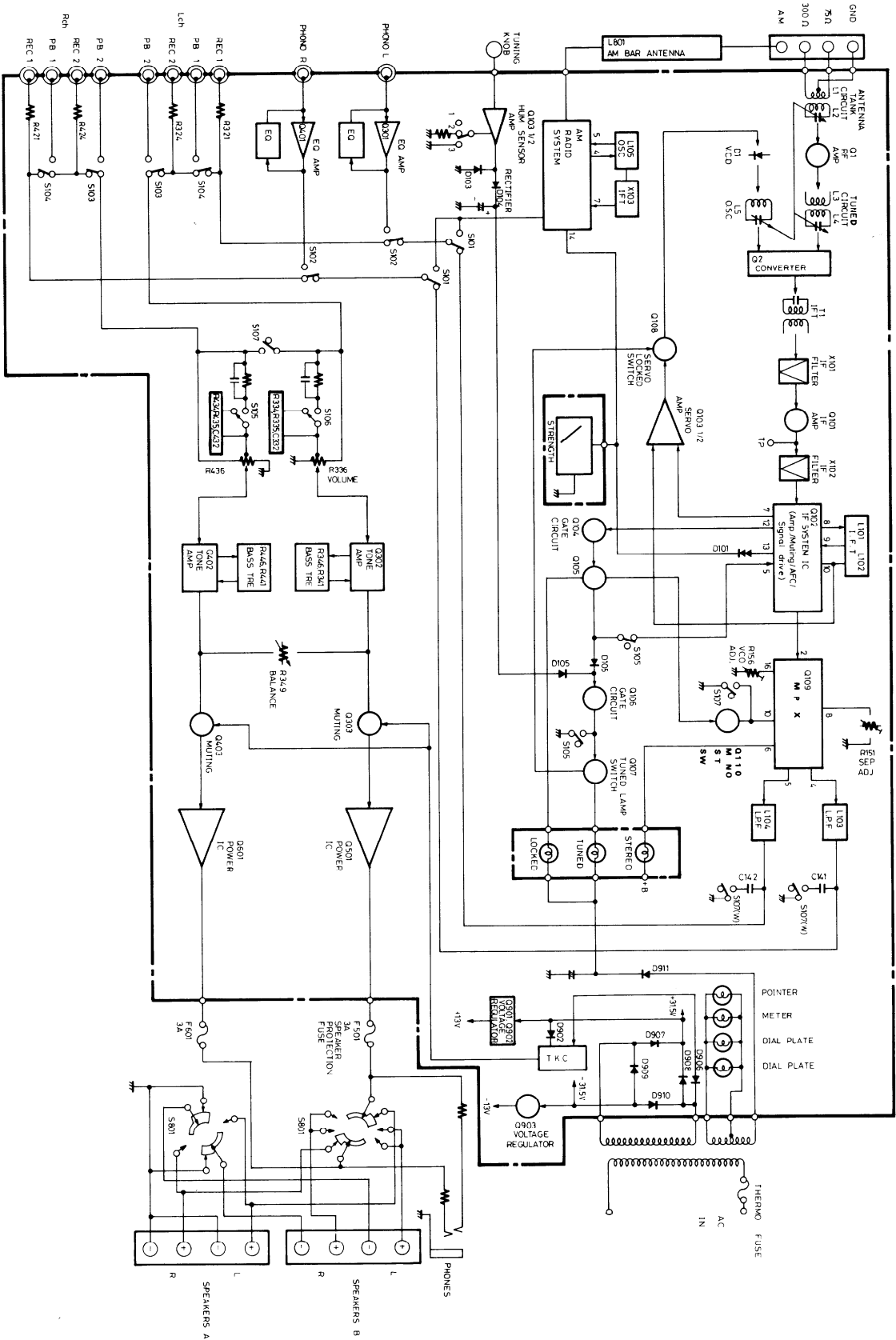

### IC BLOCK DIAGRAM LA 1230 BLOCK DIAGRAM

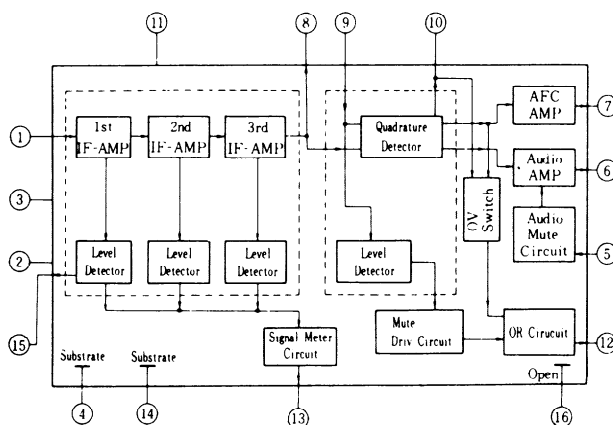

### LA3350 BLOCK DIAGRAM

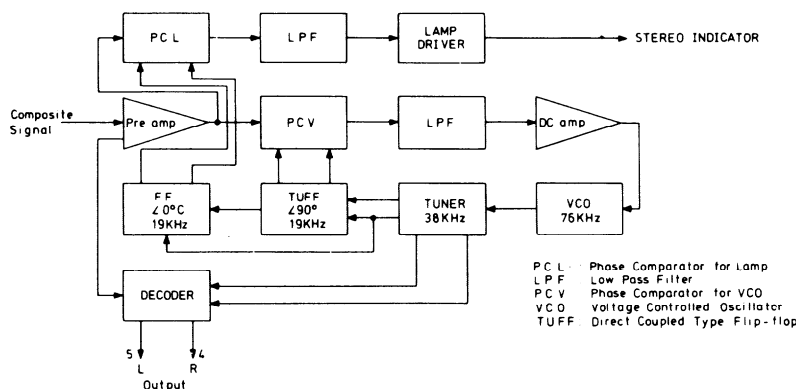

### HA-1151 EQUIVALENT CIRCUIT

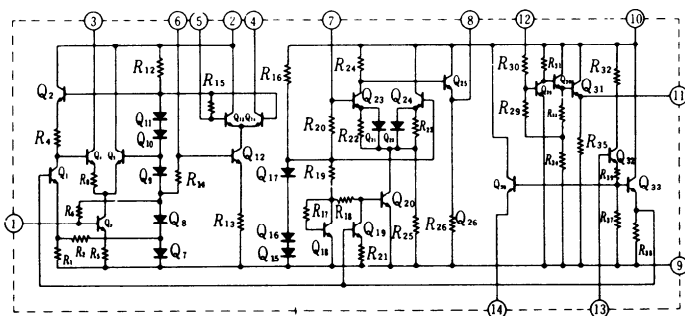

### NJM4558D, 4559DX EQUIVALENT CIRCUIT

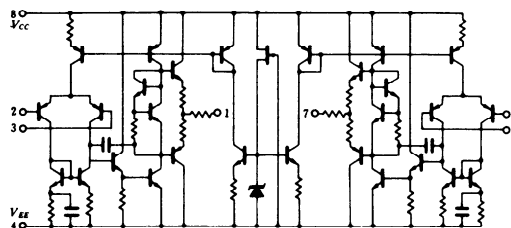

### STK-463 EQUIVALENT CIRCUIT

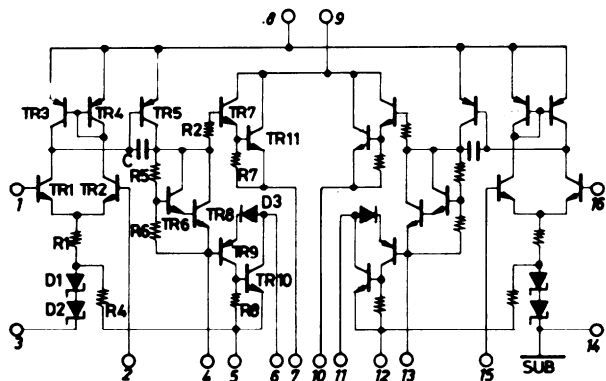

## PRINTED CIRCUIT BOARD-PARTS LIST

Circuit No.	Part No.	Description			
			C304, C404	352721019T	100 $\mu$ F, 6.3V, Elect.
			C305, C405	352742219	220 $\mu$ F, 16V, Elect.
			C306, C406		
			C309, C409	352780229T	2.2 $\mu$ F, 50V, Elect.
			C333, C433	352780229T	2.2 $\mu$ F, 50V, Elect.
			C336, C436	352780109T	1 $\mu$ F, 50V, Elect.
			C337, C437	352742209T	22 $\mu$ F, 16V, Elect.
			C343, C344	352780339T	3.3 $\mu$ F, 50V, Elect.
			C501, C601	352750479T	4.7 $\mu$ F, 25V, Elect.
			C503, C603	352781019T	100 $\mu$ F, 50V, Elect.
			C504, C604	352734709T	47 $\mu$ F, 10V, Elect.
			C506, C606	352784709T	47 $\mu$ F, 50V, Elect.
			C509, C609	352781009T	10 $\mu$ F, 50V, Elect.
			C511, C611	352781009T	10 $\mu$ F, 50V, Elect.
			C901	352741019T	100 $\mu$ F, 16V, Elect.
			C902	352781019	100 $\mu$ F, 50V, Elect.
			C903	352741019T	100 $\mu$ F, 16V, Elect.
			C904	352761019	100 $\mu$ F, 35V, Elect.
			C905	352783319	330 $\mu$ F, 50V, Elect.
			C907	352752219	220 $\mu$ F, 25V, Elect.
			C908	352784709T	47 $\mu$ F, 50V, Elect.
			C909	352781019	100 $\mu$ F, 50V, Elect.
			C910	352741019T	100 $\mu$ F, 16V, Elect.
			C911	352742219	220 $\mu$ F, 16V, Elect.
			C912	352781019	100 $\mu$ F, 50V, Elect.
			C920	352744719	470 $\mu$ F, 16V, Elect.
			C923, C924	352780339T	3.3 $\mu$ F, 50V, Elect.
				<b>Resistors</b>	
			R151	5215018	N08HR1KBC, Semi-fixed
			R156	5215020	N08HR5KBC, Semi-fixed
			R336, R436	5104101	N16RDTL100KW100KB40, Volume control variable
			R341, R441	5148047	N16RGL250KC40, Treble control variable
			R346, R446	5148047	N16RGL250KC40, Bass control variable
			R502, R602	441521014	100 $\Omega$ , 1/2W, Metal oxide film
			R504, R604	441521024	3.3 k $\Omega$ , 1/2W, Metal oxide film
			R505, R605	441521024	1 k $\Omega$ , 1/2W, Metal oxide film
			R507, R607	451633394	0.33 $\Omega$ , 1W, Metal
			R902	441622704	27 $\Omega$ , 1W, Metal oxide film
			R903	441523324	3.3 k $\Omega$ , 1/2W, Metal oxide film
			R908	441622224	2.2 k $\Omega$ , 1W, Metal oxide film
			R910	441523324	3.3 k $\Omega$ , 1/2W, Metal oxide film
			R911	441523914	390 $\Omega$ , 1/2W, Metal oxide film
				<b>Switches</b>	
			S101-S104	25035186	NPS-242-222-L150, Selector/Tape monitor
			S105-S107	25035196	NPS-322-L160, Muting/Loudness/Mode
				<b>Terminals</b>	
			P801	25045041	NPJ-6PDBL18, Phono/ Tape 2
			P802	25045020	NPJ-4PDBL11, Tape 1
			P803	250199	S-13316, DIN
				<b>Fuseholder</b>	
			F904a	25050052	S-N5053
			F904	252074	2A-SE-EAK
				<b>Front end</b>	
				240042	FF127U13
			<b>Rectifier pc board (NAPS-863 a) — Parts list</b>		
Circuit No.	Part No.	Description			
				<b>Diodes</b>	
			D906	223848	GP08B or
				223804	SR1K-2
			D907-D910	223845	GP20D



Circuit No.	Part No.	Description
C913, C914	<b>Capacitors</b>	
	3504123	4,700 $\mu$ F, 40 V, Elect.
	<b>Fuseholders</b>	
F901, F902	25050052	S-N5053
	<b>Fuse</b>	
	252078	5A-SE-EAK

**Dial illumination lamp pc board (NAPL-865) – Parts list**  
210054A PL6.3V 0.25A, Lamp

**Meter illumination lamp pc board (NAPL-866) – Parts list**  
210032B PL6.3V 0.25A, Lamp

## ALIGNMENT PROCEDURES

### INSTRUMENTS REQUIRED

- DC Voltmeter
- AM Sweep Generator
- AM/FM Signal Generator
- AC VTVM
- Oscilloscope
- Monitorscope
- Distortion Analyzer
- Stereo Modulator
- Frequency Counter

#### (1) AM IF ALIGNMENT

- Set SELECTOR switch to AM.
- Set radio dial to quiet point.

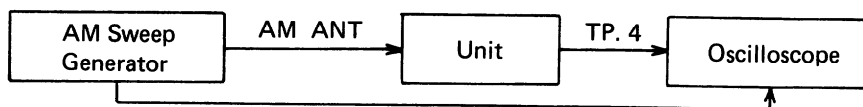

Set signal	Adjust	Oscilloscope	Remarks
455 kHz	X103	Maximum Symmetrical Response	Usually not necessary to adjust

#### (2) AM RF ALIGNMENT

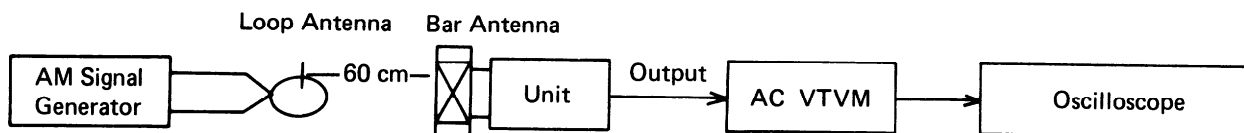

Step	Set Signal	Set Radio Dial	Adjust	VTVM reading	Remarks
1	515 kHz 400 Hz 30%	Lower end (515 kHz)	L105	Maximum	Repeat steps 1 and 2 as necessary
2	1680 kHz 400 Hz 30%	Upper end (1680 kHz)	TC152	Maximum	
3	600 kHz 400 Hz 30%	600 kHz	L801	Maximum	Repeat steps 3 and 4 as necessary
4	1400 kHz 400 Hz 30%	1400 kHz	TC151	Maximum	

#### (3) FM ALIGNMENT

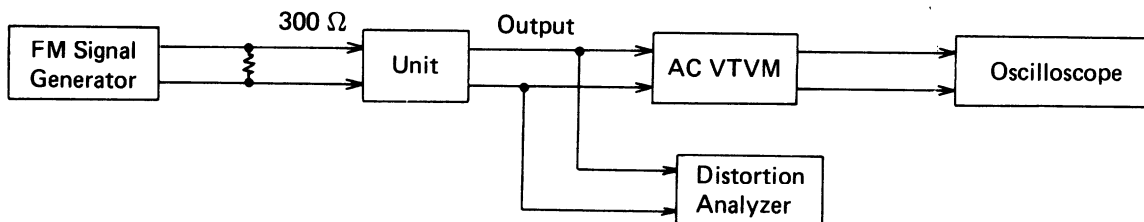

Step	FM Signal Generator	Dial to set	Adjust	Output Indicator	Adjust for	Remarks
1	No signal	Quiet Point	L101	Tuning Indicator	Center	Repeat Steps 1 and 2 as necessary
2	98 MHz 65 dBf 1 kHz 75 kHz devi.	98 MHz	L102	Distortion Analyzer	Minimum	
3	98 MHz, 65 dBf 1 kHz 75 kHz devi.	98 MHz	T1	Distortion Analyzer	Minimum	

#### (4) MULTIPLEX ALIGNMENT

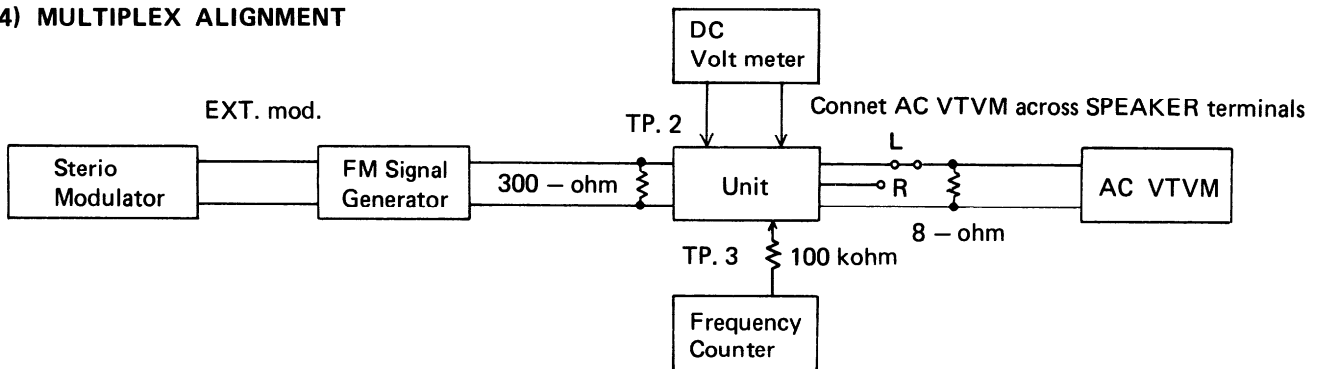

Step	FM Signal Generator	Stereo Modulator	Dial to set	Adjust	Output Indicator	Adjust for	Remarks
1	98 MHz no mod. 65 dBf	—	98 MHz	R156	Frequency Counter	19,000±19Hz	
2	STEREO INDICATOR should light up when stereo program is being received.						
3	98 MHz EXT. Mod. 65 dBf	Pilot Sig. 9% Main & Sub Sig. 1kHz Lch 91%	98 MHz	R151	AC VTVM Right ch.	Minimum	Repeat Steps 3 & 4 as necessary same separation
4	Same as above	Pilot Sig. 9% Main & Sub Sig. 1 kHz Rch 91%	98 MHz		AC VTVM Left ch.	Minimum	

## STRINGING DIAGRAM

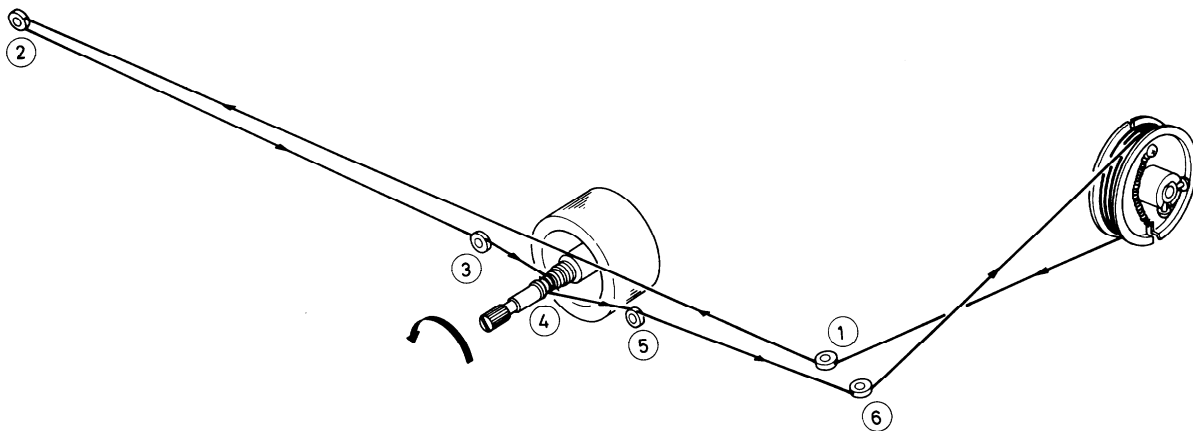

1. Close the variable capacitor complete and tie the dial cord to the spring of the drum.
2. Thread the dial cord in the direction of arrow from ① to ③ and wind the dial cord three turns around the tuning shaft counter clockwise.
3. Thread the dial cord ⑤ and ⑥.
4. Wind the dial cord 1½ turns around the dial drum.

# PRINTED CIRCUIT BOARD-PARTS LIST

## D/W model

### Tuner and amplifier pc board — Parts list

Circuit No.	Part No.	Description
<b>ICs</b>		
Q102	222455	LA-1230
Q103	222465	NJM-4558D
Q109	222449	LA3350
Q111	222418	HA-1151
Q301, Q302	222534	NJM-4559DX
Q401, Q402		
Q501, Q601	222020	STK-463
<b>Transistors</b>		
Q101	2210746	2SC945A (P)
Q104-108	2210746 or	2SC945A (P) or
Q110	2211255	2SC1815 (GR)
Q901	2201073 or	2SD880 (O) or
	2201074	2SD880 (Y)
Q303, Q403	2211255 or	2SC1815 (GR) or
Q902	2211256	2SC1815 (BL)
Q903	2211423 or	2SA817 (O) or
	2211424	2SA817 (Y)
<b>Diodes</b>		
D101, D110	4000022	VD1212
D102-D106	223105	1S1555
D109, D111		
D112	223943 or	RD4.7EB or
	224011	YZ047
D901	223915	WZ-150
D902, D911	223804 or	SR1K-2 or
	223848	GP-08B
D903, D904	223105	1S1555
D905	224060	05Z15L
<b>Transformer &amp; coils</b>		
L101	233148	NFIF6010P
L102	233149	NFIF6010S
L103, L104	233107	NMC5002
L105	232065	NMO2002
L106	232041	NIT0509
L501, L601	231001	S-1.3B
<b>Ceramic filters</b>		
X101, X102	3010003	SFE10.7MA
X103	3010004	CFZ-455C
<b>Capacitors</b>		
C105	352741009T	10 $\mu$ F, 16V, Elect.
C106	352780339T	3.3 $\mu$ F, 50V, Elect.
C116	352780109T	1 $\mu$ F, 50V, Elect.
C117	352742209T	22 $\mu$ F, 16V, Elect.
C119	352744709T	47 $\mu$ F, 16V, Elect.
C120	352741009T	10 $\mu$ F, 16V, Elect.
C121	352784799T	0.47 $\mu$ F, 50V, Elect.
C122	352750479T	4.7 $\mu$ F, 25V, Elect.
C123	352784799T	0.47 $\mu$ F, 50V, Elect.
C124	352721019T	100 $\mu$ F, 6.3V, Elect.
C127	352741019T	100 $\mu$ F, 16V, Elect.
C128	352741009T	10 $\mu$ F, 16V, Elect.
C129	352780109T	1 $\mu$ F, 50V, Elect.
C130	392883397T	0.33 $\mu$ F, 50V, LL
C131	392884797T	0.47 $\mu$ F, 50V, LL
C132	392882297T	0.22 $\mu$ F, 50V, LL
C133	372521525	1,500pF, 50V, ST
C137, C138	352782299T	0.22 $\mu$ F, 50V Elect.
C150	352741009T	10 $\mu$ F, 16V, Elect.
C151	372523614	360pF $\pm$ 5%, 50V, ST
C156	352780109T	1 $\mu$ F, 50V, Elect.
C155	352780339T	3.3 $\mu$ F, 50V, Elect.
C158	352741019T	100 $\mu$ F, 16V, Elect.
C161	352722219T	220 $\mu$ F, 6.3V, Elect.

C301, C401	352780229T	2.2 $\mu$ F, 50V, Elect.
C304, C404	352721019T	100 $\mu$ F, 6.3V, Elect.
C305, C405	352742219	220 $\mu$ F, 16V, Elect.
C306, C406		
C309, C409	352780229T	2.2 $\mu$ F, 50V, Elect.
C333, C433	352780229T	2.2 $\mu$ F, 50V, Elect.
C336, C436	352780109T	1 $\mu$ F, 50V, Elect.
C337, C437	352742209T	22 $\mu$ F, 16V, Elect.
C343, C344	352780339T	3.3 $\mu$ F, 50V, Elect.
C501, C601	352750479T	4.7 $\mu$ F, 25V, Elect.
C503, C603	352781019T	100 $\mu$ F, 50V, Elect.
C504, C604	352734709T	47 $\mu$ F, 10V, Elect.
C506, C606	352784709T	47 $\mu$ F, 50V, Elect.
C509, C609	352781009T	10 $\mu$ F, 50V, Elect.
C511, C611	352781009T	10 $\mu$ F, 50V, Elect.
C901	352741019T	100 $\mu$ F, 16V, Elect.
C902	352781019	100 $\mu$ F, 50V, Elect.
C903	352741019T	100 $\mu$ F, 16V, Elect.
C904	352761019	100 $\mu$ F, 35V, Elect.
C905	352783319	330 $\mu$ F, 50V, Elec.
C907	352752219	220 $\mu$ F, 25V, Elect.
C908	352784709T	47 $\mu$ F, 50V, Elect.
C909	352781019	100 $\mu$ F, 50V, Elect.
C910	352741019T	100 $\mu$ F, 16V, Elect.
C911	352742219	220 $\mu$ F, 16V, Elect.
C912	352781019	100 $\mu$ F, 50V, Elect.
C920	352742219	470 $\mu$ F, 16V, Elect.
C923, C924	352780339T	3.3 $\mu$ F, 50V, Elect.

### Resistors

R151	5215018	N08HR1KBC, Semi-fixed
R156	5215020	N08HR5KBC, Semi-fixed
R336, R436	5104101	N16RDTL100KW100KB40, Volume control variable
R341, R441	5148047	N16RGL250KC40, Treble control variable
R346, R446	5148047	N16RGL250KC40, Bass control variable
R502, R602	441521014	100 $\Omega$ , 1/2W, Metal oxide film
R504, R604	441521024	3.3 k $\Omega$ , 1/2W, Metal oxide film
R505, R605	441521024	1 k $\Omega$ , 1/2W, Metal oxide film
R507, R607	451633394	0.33 $\Omega$ , 1W, Metal
R902	441622704	27 $\Omega$ , 1W, Metal oxide film
R903	441523324	3.3 k $\Omega$ , 1/2W, Metal oxide film
R908	441622224	2.2 k $\Omega$ , 1W, Metal oxide film
R910	441523324	3.3 k $\Omega$ , 1/2W, Metal oxide film
R911	441523914	390 $\Omega$ , 1/2W, Metal oxide film

### Switches

S101-S104	25035186	NPS-242-222-L150, Selector/Tape monitor
S105-S107	25035196	NPS-322-L160, Muting/Loudness/Mode

### Terminals

P801	25045041	NPJ-6PDBL18, Phono/Tape 2
P802	25045020	NPJ-4PDBL11, Tape 1

### Fuseholder

F903a	250113	S-N5051 (D model)
F904a	250113	S-N5051 (W model)

### Fuse

F903	252048	3A (ST-6), AC (D model)
F904	252003	3A-T, AC (W model)

### Front end

240042	FF127U13
--------	----------

### Rectifier circuit pc board (NAPS-863) — Parts list

Circuit No.	Parts No.	Description
D906	233848 or	GP08B or
	223804	SR-1K2
D907-D910	223845	GP20D

Circuit No.	Part No.	Description
	<b>Capacitors</b>	
C913, C914	3504123	4.700 $\mu$ F, 40V, Elect.

**Dial illumination lamp pc board (NAPL-865) – Parts list**

210054A PL6.3V 0.25A, Lamp

**Meter illumination lamp pc board (NAPL-866) – Parts list**

PL806 210032B PL6.3V 0.25A, Lamp

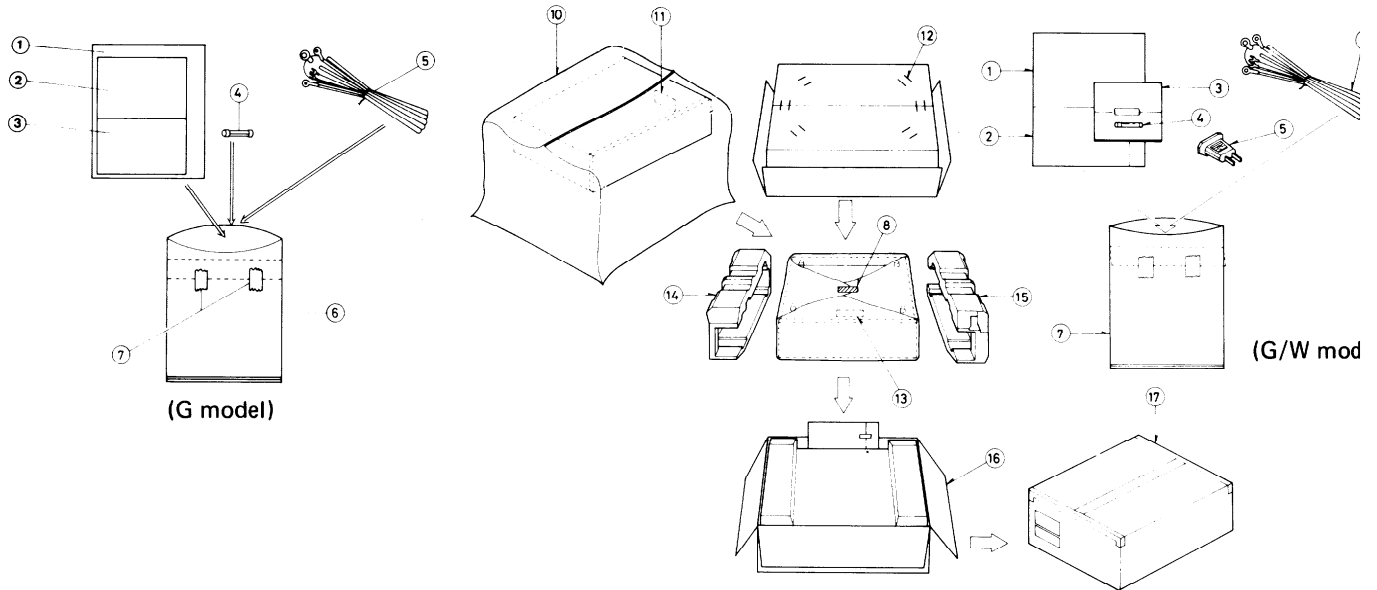
**PACKING PROCEDURES****PACKING PROCEDURES – PARTS LIST****(D model)**

Ref. No.	Parts No.	Description
1	29340416	Instruction manual
2	29358002	Service station list (N)
3	29365006	Warranty card (N)
4	252014	4A-T, Fuse
5	292064	FM antenna
6	29100006	Poly bag
7	261504	Tape
8	261504	Tape
10	29100033A	750 x 650 mm, Poly bag
11	29360362	Label (N)
12	282301	Sealing hook
13	29360363	Caution label (N)
14	29090493	Pad (R)
15	29090494	Pad (L)
16	29050350	Carton box
17	260012	Tape
	29355045	Sensor tag

(N) : Only U.S.A. model

**(W/G model)**

Ref. No.	Parts No.	Description
1	29340417	Instruction manual
2	29365005-2	Warranty card (V)
3	29100002	Poly bag (W)
4	252014	4A-T, Fuse
5	25055018	CV-K-1, Conversion plug (W)
6	292064	FM antenna
7	29100006	Poly bag
8	261504	Tape
10	29100033A	750 x 650 mm, Poly bag
12	282301	Sealing hook
14	29090493	Pad (R)
15	29090494	Pad (L)
16	29050350	Carton box
17	260012	Tape
	29355045	Sensor tag

(V): Only Germany model

(W): Only W model

**ONKYO CORPORATION**International Division: No. 24 Mori Bldg., 23-5, 3-chome, Nishi-Shinbashi, Minato-ku, Tokyo, Japan  
Telex: 2423551 ONKYO J. Phone: 03-432-6981**ONKYO U.S.A. CORPORATION**Eastern Office  
42-07 20th Avenue, Long Island City, New York 11105, U.S.A. Phone: (212) 728-4639  
Midwest Office  
935 Sivert Drive, Wooddale, Illinois 60191, U.S.A. Phone: (312) 595-2970**ONKYO DEUTSCHLAND GMBH, ELECTRONICS**

8034 München-Germering, Industriestrasse 18, West Germany. Telex: 521726 Telefon: (089)-84-5041

# SCHEMATIC DIAGRAM

MODEL TX-2000D (120V model)

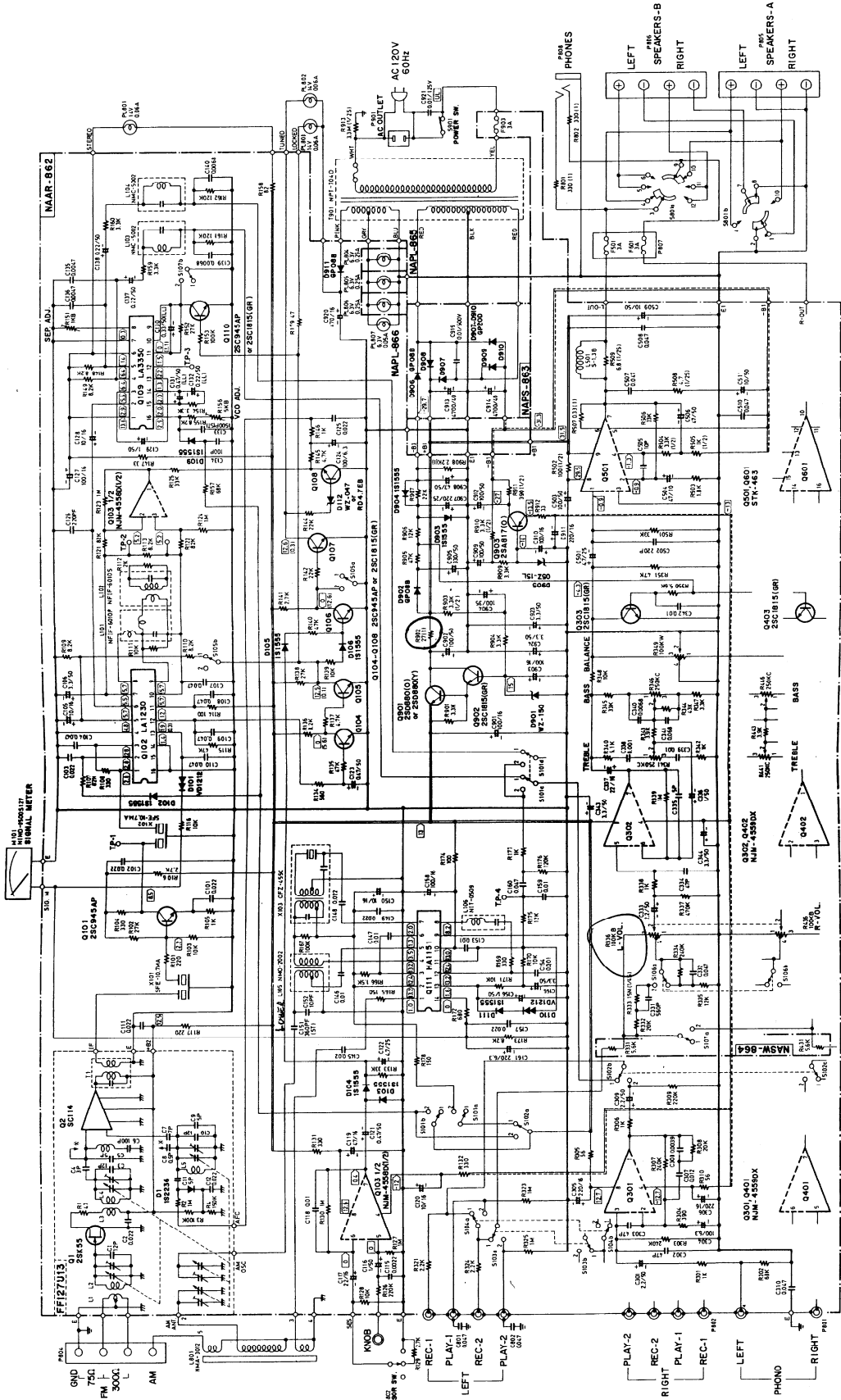

NOTES

- \*ALL RESISTORS ARE IN OHMS 1/4 WATT UNLESS OTHERWISE NOTED.
- \*CAPACITORS ARE IN MICROFARADS UNLESS OTHERWISE NOTED.
- \*ELECTRONIC COMPONENTS ONLY ARE IN J.P.N.Y.
- \*VOLTAGE (MEASURED WITH A.T.V.M.)
- \*V DC VOLTAGE (NO INPUT SIGNAL).
- \*V DC VOLTAGE (FM STEREO)

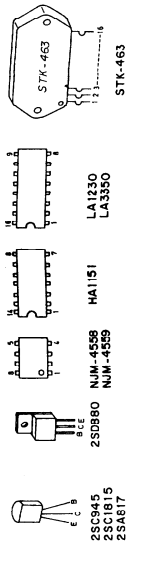

- S801 POWER 2-OFF
- S102-3 SELECTOR 2-AM PHONO
- S103-5 3-MONO 2-TAPE-2
- S104-6 3-MONO-2 2-TAPE-1
- S105-5 5-MONO-1 2-OFF
- S106-5 5-MUTE/LOCK 2-ON
- S107-5 5-LOUDNESS 2-ON
- S107-5 5-MODE 1-OFF 2-3 3-4 4-A-B
- S108-4 5-SPEAKER 1-HIGH 2-NORMAL 3-LOW
- S802 SENSOR

**SCHEMATIC DIAGRAM**  
MODEL TX-2000W (120/220 V model)

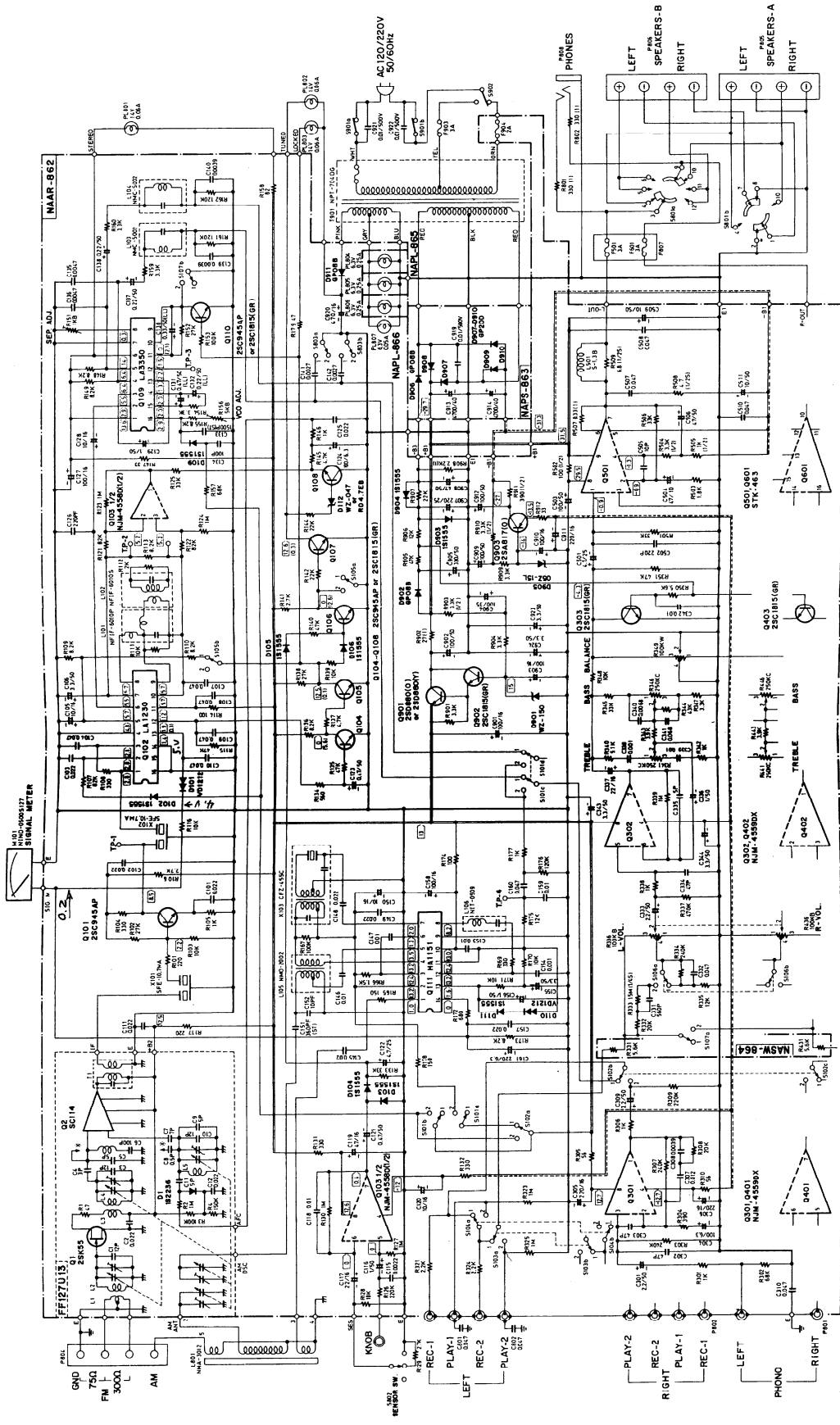

- 5901 POWER 2-OFF  
 S101 a-c SELECTOR 2-AM  
 S102 a-c SELECTOR 2-AM  
 S103 a-b T-MON-1 2-PHONO  
 S104 a-b T-MON-1 2-TAPE-2  
 S105 a-b T-MON-1 2-TAPE-1  
 S106 a-b T-MON-1 2-AM  
 S107 a-b T-MON-1 2-AM  
 S108 a-b T-MON-1 2-AM  
 S109 a-b T-MON-1 2-AM  
 S110 a-b T-MON-1 2-AM  
 S111 a-b T-MON-1 2-AM  
 S112 a-b T-MON-1 2-AM  
 S113 a-b T-MON-1 2-AM  
 S114 a-b T-MON-1 2-AM  
 S115 a-b T-MON-1 2-AM  
 S116 a-b T-MON-1 2-AM  
 S117 a-b T-MON-1 2-AM  
 S118 a-b T-MON-1 2-AM  
 S119 a-b T-MON-1 2-AM  
 S120 a-b T-MON-1 2-AM  
 S121 a-b T-MON-1 2-AM  
 S122 a-b T-MON-1 2-AM  
 S123 a-b T-MON-1 2-AM  
 S124 a-b T-MON-1 2-AM  
 S125 a-b T-MON-1 2-AM  
 S126 a-b T-MON-1 2-AM  
 S127 a-b T-MON-1 2-AM  
 S128 a-b T-MON-1 2-AM  
 S129 a-b T-MON-1 2-AM  
 S130 a-b T-MON-1 2-AM  
 S131 a-b T-MON-1 2-AM  
 S132 a-b T-MON-1 2-AM  
 S133 a-b T-MON-1 2-AM  
 S134 a-b T-MON-1 2-AM  
 S135 a-b T-MON-1 2-AM  
 S136 a-b T-MON-1 2-AM  
 S137 a-b T-MON-1 2-AM  
 S138 a-b T-MON-1 2-AM  
 S139 a-b T-MON-1 2-AM  
 S140 a-b T-MON-1 2-AM  
 S141 a-b T-MON-1 2-AM  
 S142 a-b T-MON-1 2-AM  
 S143 a-b T-MON-1 2-AM  
 S144 a-b T-MON-1 2-AM  
 S145 a-b T-MON-1 2-AM  
 S146 a-b T-MON-1 2-AM  
 S147 a-b T-MON-1 2-AM  
 S148 a-b T-MON-1 2-AM  
 S149 a-b T-MON-1 2-AM  
 S150 a-b T-MON-1 2-AM  
 S151 a-b T-MON-1 2-AM  
 S152 a-b T-MON-1 2-AM  
 S153 a-b T-MON-1 2-AM  
 S154 a-b T-MON-1 2-AM  
 S155 a-b T-MON-1 2-AM  
 S156 a-b T-MON-1 2-AM  
 S157 a-b T-MON-1 2-AM  
 S158 a-b T-MON-1 2-AM  
 S159 a-b T-MON-1 2-AM  
 S160 a-b T-MON-1 2-AM  
 S161 a-b T-MON-1 2-AM  
 S162 a-b T-MON-1 2-AM  
 S163 a-b T-MON-1 2-AM  
 S164 a-b T-MON-1 2-AM  
 S165 a-b T-MON-1 2-AM  
 S166 a-b T-MON-1 2-AM  
 S167 a-b T-MON-1 2-AM  
 S168 a-b T-MON-1 2-AM  
 S169 a-b T-MON-1 2-AM  
 S170 a-b T-MON-1 2-AM  
 S171 a-b T-MON-1 2-AM  
 S172 a-b T-MON-1 2-AM  
 S173 a-b T-MON-1 2-AM  
 S174 a-b T-MON-1 2-AM  
 S175 a-b T-MON-1 2-AM  
 S176 a-b T-MON-1 2-AM  
 S177 a-b T-MON-1 2-AM  
 S178 a-b T-MON-1 2-AM  
 S179 a-b T-MON-1 2-AM  
 S180 a-b T-MON-1 2-AM  
 S181 a-b T-MON-1 2-AM  
 S182 a-b T-MON-1 2-AM  
 S183 a-b T-MON-1 2-AM  
 S184 a-b T-MON-1 2-AM  
 S185 a-b T-MON-1 2-AM  
 S186 a-b T-MON-1 2-AM  
 S187 a-b T-MON-1 2-AM  
 S188 a-b T-MON-1 2-AM  
 S189 a-b T-MON-1 2-AM  
 S190 a-b T-MON-1 2-AM  
 S191 a-b T-MON-1 2-AM  
 S192 a-b T-MON-1 2-AM  
 S193 a-b T-MON-1 2-AM  
 S194 a-b T-MON-1 2-AM  
 S195 a-b T-MON-1 2-AM  
 S196 a-b T-MON-1 2-AM  
 S197 a-b T-MON-1 2-AM  
 S198 a-b T-MON-1 2-AM  
 S199 a-b T-MON-1 2-AM  
 S200 a-b T-MON-1 2-AM

**ONKYO CORPORATION**

- NOTES**  
 \*ALL RESISTORS ARE IN OHMS, 1/4 WATT UNLESS OTHERWISE NOTED.  
 \*ALL CAPACITORS ARE IN  $\mu$ F, 50V UNLESS OTHERWISE NOTED.  
 \*ELECTROLYTIC CAPACITORS (48-) ARE IN JF/W/V.  
 \*VOLTAGE (MEASURED WITH V.T.M.M.) ARE IN JF/W/V.  
 \*DC VOLTAGE (PH STEREO)
- STK-463  
 LA1330  
 LA3350  
 HA1151  
 NJM-4558  
 NJM-4559  
 2SC945  
 2SC1815  
 2SA617

**SCHEMATIC DIAGRAM**  
MODEL TX-2000G (220V model)

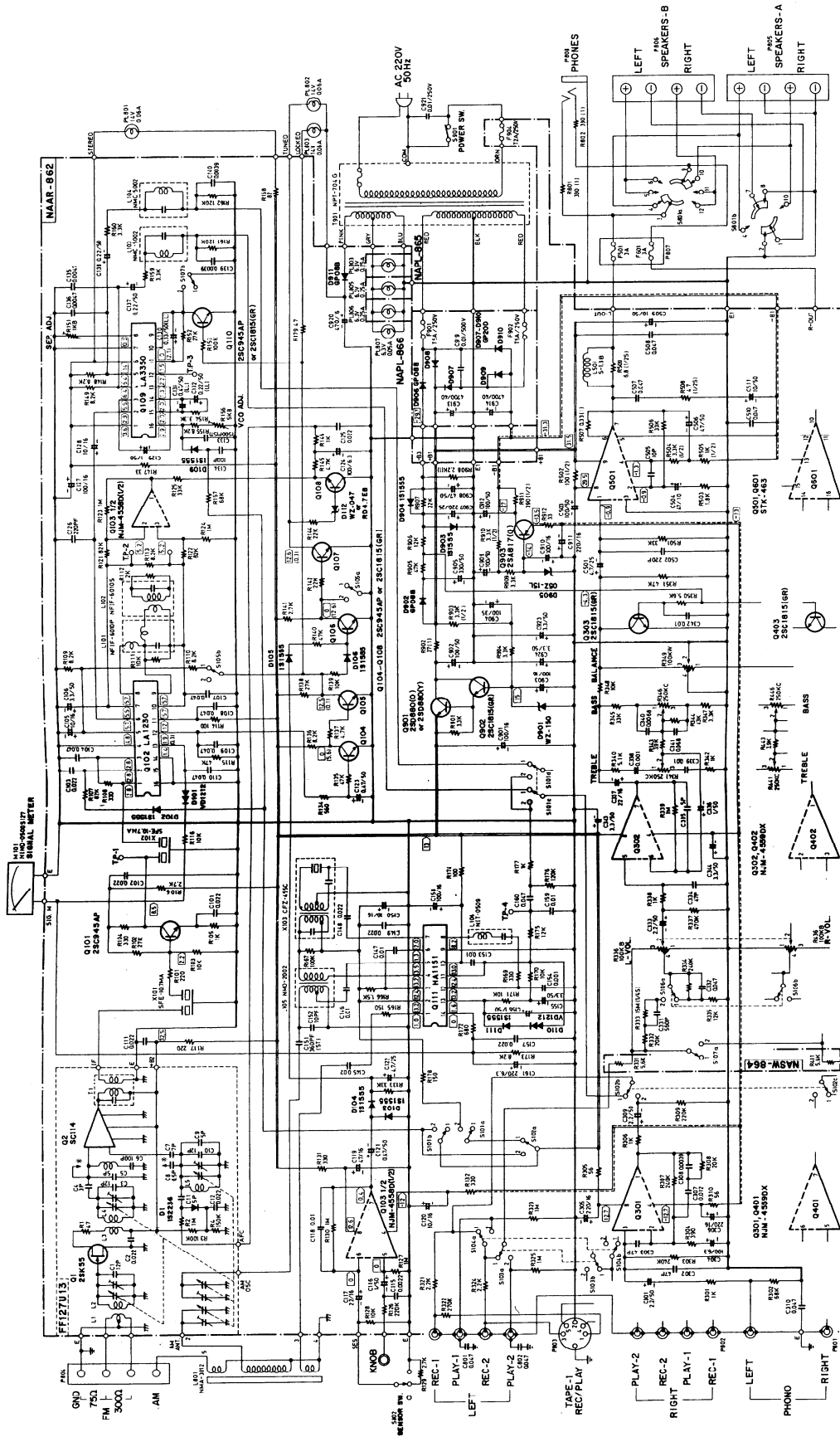

**NOTES**  
 \* ALL RESISTORS ARE IN OHMS, 1/4 WATT UNLESS OTHERWISE NOTED.  
 \* ALL CAPACITORS ARE IN JF 50V UNLESS OTHERWISE NOTED.  
 \* VOLTAGE MEASURED WITH Y.T.V.M. ARE IN JF.F.W.V.  
 \* V DC VOLTAGE (NO INPUT SIGNAL).  
 \* 1 V DC VOLTAGE (FM STEREO).

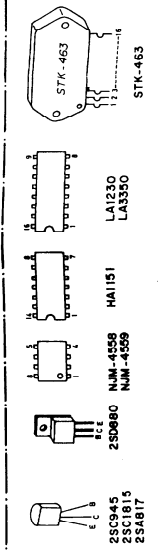

- S901 POWER
- S101a-d SELECTOR
- S102a-c SELECTOR
- S103a-b TUNER
- S104a-b TUNER
- S105a-b TUNER
- S106a-b MUTE/LOCK
- S106c-b LOUDNESS
- S107a-b MODE
- S108a-b SPEAKER
- S802 SENSOR

**ONKYO CORPORATION**