

ONKYO SERVICE MANUAL

QUARTZ SYNTHESIZED TUNER AMPLIFIER MODEL TX-26

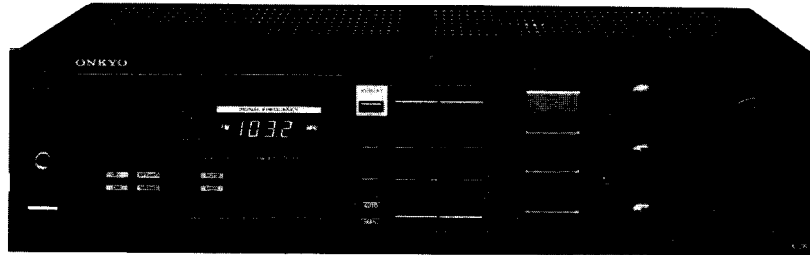

UD, UDN, BUD, BUDN	120V AC, 60Hz
UG, UGV, BUG, BUGV	220V AC, 50Hz
UW	120 or 220V AC, 50/60Hz
UQB	240V AC, 50Hz

Silver and black models

SAFETY-RELATED COMPONENT WARNING!!

COMPONENTS IDENTIFIED BY MARK \triangle ON THE SCHEMATIC DIAGRAM AND IN THE PARTS LIST ARE CRITICAL FOR RISK OF FIRE AND ELECTRIC SHOCK. REPLACE THESE COMPONENTS WITH ONKYO PARTS WHOSE PARTS NUMBERS APPEAR AS SHOWN IN THIS MANUAL.

MAKE LEAKAGE-CURRENT OR RESISTANCE MEASUREMENTS TO DETERMINE THAT EXPOSED PARTS ARE ACCEPTABLY INSULATED FROM THE SUPPLY CIRCUIT BEFORE RETURNING THE APPLIANCE TO THE CUSTOMER.

SPECIFICATIONS

AMPLIFIER SECTION

Power Output:	38 watts per channel, min. RMS, at 8 ohms, both channels driven, from 20 Hz to 20 kHz, with no more than 0.08% THD.
Music Power Output:	2 x 80 watts at 4 ohms, 1 kHz (DIN) 2 x 53 watts at 8 ohms, 1 kHz (DIN)
Continuous Power Output:	2 x 50 watts at 4 ohms, 1 kHz (DIN) 2 x 40 watts at 8 ohms, 1 kHz (DIN)
Total Harmonic Distortion:	0.08% at rated power 0.08% at 1 watt output
IM Distortion:	0.08% at rated power 0.08% at 1 watt output
Damping Factor:	35 at 8 ohms
Frequency Response:	20 - 30,000 Hz ± 1 dB
RIAA Deviation:	20 - 20,000 Hz ± 0.8 dB
Sensitivity and Impedance:	Phono: 2.5 mV/50 kohms Tape Play: 150 mV/50 kohms Tape Rec: 150 mV/3.5 kohms (phono)
Phono Overload:	180 mV RMS at 1kHz, 0.08% THD
Signal-to-Noise Ratio:	Phono: 85 dB (at 10 mV input, A weighted) 75 dB (IHF A-202) Tape: 95 dB (A weighted) 80 dB (IHF A-202)
Tone Controls:	Bass: ± 8 dB at 100 Hz Treble: ± 8 dB at 10 kHz
Loudness (-30 dB):	+7 dB at 70Hz, +5 dB at 10 kHz

ONKYO
AUDIO COMPONENTS

TUNER SECTION**FM:**

	120V model	220/240V model
Tuning Range:	87.5 – 108.0 MHz (100 kHz steps)	87.5 – 108.0 MHz (50 kHz steps)
Usable sensitivity:	Mono: 11.2 dBf, 2.0 μ V Stereo: 17.2 dBf, 4.0 μ V	Mono: 12.8 dBf, 1.2 μ V Stereo: 18.0 dBf, 2.2 μ V
50 dB Quieting Sensitivity:	Mono: 17.2 dBf, 4.0 μ V Stereo: 37.2 dBf, 40 μ V	Mono: 18.0 dBf, 2.2 μ V Stereo: 37.2 dBf, 20 μ V
Capture Ratio:	1.5 dB	1.5dB
Image Rejection Ratio:	40 dB	85 dB
IF Rejection Ratio:	90 dB	90 dB
Signal-to Noise Ratio:	Mono: 71 dB Stereo: 66 dB	Mono: 71 dB Stereo: 66 dB
Selectivity:	55 dB	50 dB DIN (\pm 300 kHz 40 kHz dev.)
AM Suppression Ratio:	50 dB	50 dB
Harmonic Distortion:	Mono: 0.15% Stereo: 0.3%	Mono: 0.15% Stereo: 0.3%
Frequency Response:	30 – 15,000 Hz \pm 1.5 dB	30 – 15,000 Hz \pm 1.5 dB
Stereo Separation:	40 dB at 1 kHz 30 dB at 100 – 10,000 Hz	40 dB at 1 kHz 30 dB at 100 – 10,000 Hz
Tuning Level (Hi/Lo):	—	—
Muting Level:	17.2 dBf, 4.0 μ V	17.2 dBf, 2.0 μ V
Stereo Threshold:	17.2 dBf, 4.0 μ V	17.2 dBf, 2.0 μ V

AM:

Tuning Range:	520 – 1,710 kHz (10 kHz steps)	522 – 1,611 kHz (9 kHz steps)
Usable Sensitivity:	30 μ V	30 μ V
Image Rejection Ratio:	40 dB	40 dB
IF Rejection Ratio:	30 dB	30 dB
Signal-to-Noise Ratio:	40 dB	40 dB
Harmonic Distortion:	0.8%	0.8%

GENERAL:

Semiconductors:	EETs: 6 TR: 30 ICs: 10 Diodes: 76	EETs: 6 TR: 34 ICs: 10 Diodes: 81
Dimensions (WxHxD):	418 x 112 x 340 mm (16 1/2" x 4 1/2" x 13 3/8")	418 x 112 x 340 mm (16 1/2" x 4 1/2" x 13 3/8")
Weight:	7.1 kg., 15.6 lbs.	7.1 kg., 15.6 lbs.

TABLE OF CONTENTS

Specifications	1	Pc board parts list and view from component side	
Service procedures	3	FM/AM tuner pc board	19
Block diagram – Amplifier section –	4	Digital circuit pc board	23
Block diagram – D (120V) model –	5	Fluorescent indicator tube pc board	23
Block diagram – G (220V) and Q (240V) models –	6	Tuner switch pc board	24
Block diagram – W (120 or 220V) model –	7	Power supply and amplifier pc board	27
Exploded view	8	Speaker switch pc board	27
Parts list	9	Fuse terminal pc board	27
Circuit description	10	Equalizer amplifier pc board	31
Adjustment procedures	15	Tone control/Switch pc boards	32
Schematic diagram of tuner section		Block diagram of IC	35
– W model –	17	Packing view	36
– D model –	21		
– G/Q models –	25		
Schematic diagram of amplifier section			
– D/W models –	29		
– G/Q models –	33		

SERVICE PROCEDURES

1. Replacing the fuses

For continued protection against fire hazard, replace only with same type and same rating fuse.

D (120V) model

Circuit no.	Parts no.	Description
F501, F601	252059	4A (SS-2), Speaker
F901	252049	4A (ST-6), Primary

G (220V) and Q (240V) models

Circuit no.	Parts no.	Description
F501, F601	252076	3. 15A-SE-EAK, Speaker
F902	252074	2A-SE-EAK, Primary
F903, F904	252078	5A-SE-EAK, Secondary
F905, F906	252070	1A-SE-EAK, Secondary
F907	252088	250mA-SE-EAK, Secondary

W(120 or 220V) model

Circuit no.	Parts no.	Description
F501, F601	252059	4A(SS-2), Speaker
F901	252049	4A(ST-6), Primary
F902	252074	2A-SE-EAK, Primary

2. Replacing the lamps

This unit uses the lamps listed below.

Circuit no.	Parts no.	Description
PL901, PL902	210162	PL 6.3V, 250mA, Dial plate illumination

Remove the top cover.

Remove the front panel.

Remove the holder.

(See fig. 2)

3. Insulation resistance measurement (Only U.S.A. model)

Connect the insulating-resistance tester between the plug of power supply cable and terminal GND.

Specifications: $3.3 \pm 0.3M$ ohm

4. Disassembling procedures

Selector switch pc board

Remove the top cover.

Remove the all screws on the back panel.

Remove a screw holding the radiator and bracket, pcb.

5. Change of AM scan step

W models are equipped with a switch to change the AM scan step frequency from 9kHz to 10kHz. The switch is located on the back panel. This switch is set to 9kHz at the factory; change to 10kHz if gives better results in your locality.

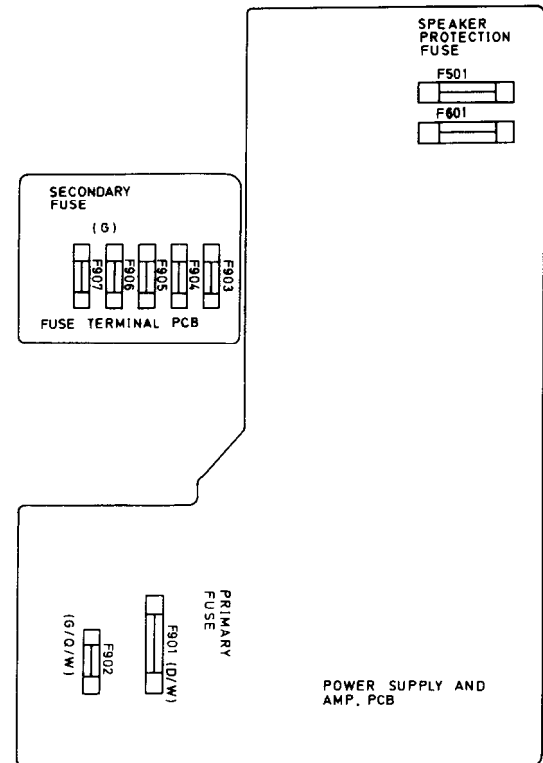

(fig. 1)

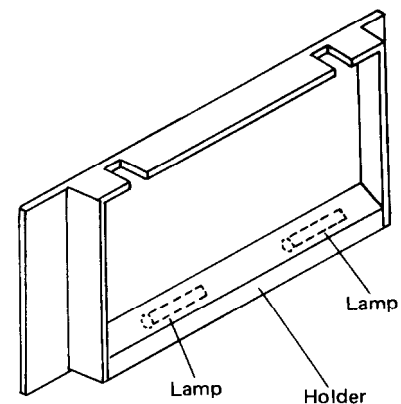

(fig. 2)

6. Change of De-emphasis

W models are equipped with a $50\mu\text{sec}$ - $75\mu\text{sec}$ selector switch. This switch is located on the back panel. This switch is set to $50\mu\text{sec}$ at the factory, but may have to be reset to $75\mu\text{sec}$ depending on the area where the unit is used.

Europe: $50\mu\text{sec}$

U.S.A.: $75\mu\text{sec}$

7. Change of voltage

W models are equipped with a voltage selector to conform with local power supplies. This switch is located on the back panel. Be sure to set this switch to match the voltage of the power supply in your area before turning the power switch on.

This switch is set to 220V at the factory. Voltage is changed by sliding the groove in the switch with the screwdriver to the right or left. Confirm that the switch has been moved all the way to the right or left before turning the power switch on.

8. Memory Preservation

This unit does not require memory preservation batteries. A built-in memory power back-up system preserves contents of the memory during power failures and even when the unit is unplugged. The unit must be plugged in and the power switch turned on and off once in order to charge the back-up system. Note that since this is not a permanent memory, the power switch must be turned on and off a few times each month to keep the back-up system operable. The period of time during which memory contents are preserved after power has last been turned off varies depending on climate and the location and placement of the unit. On the average, memory contents are protected over a period of 3 to 4 weeks (a minimum of 2 weeks) after the last time power has been turned off. This period is shorter when the unit is exposed to very high humidity or used in an area with an extremely humid climate.

BLOCK DIAGRAM

Amplifier section

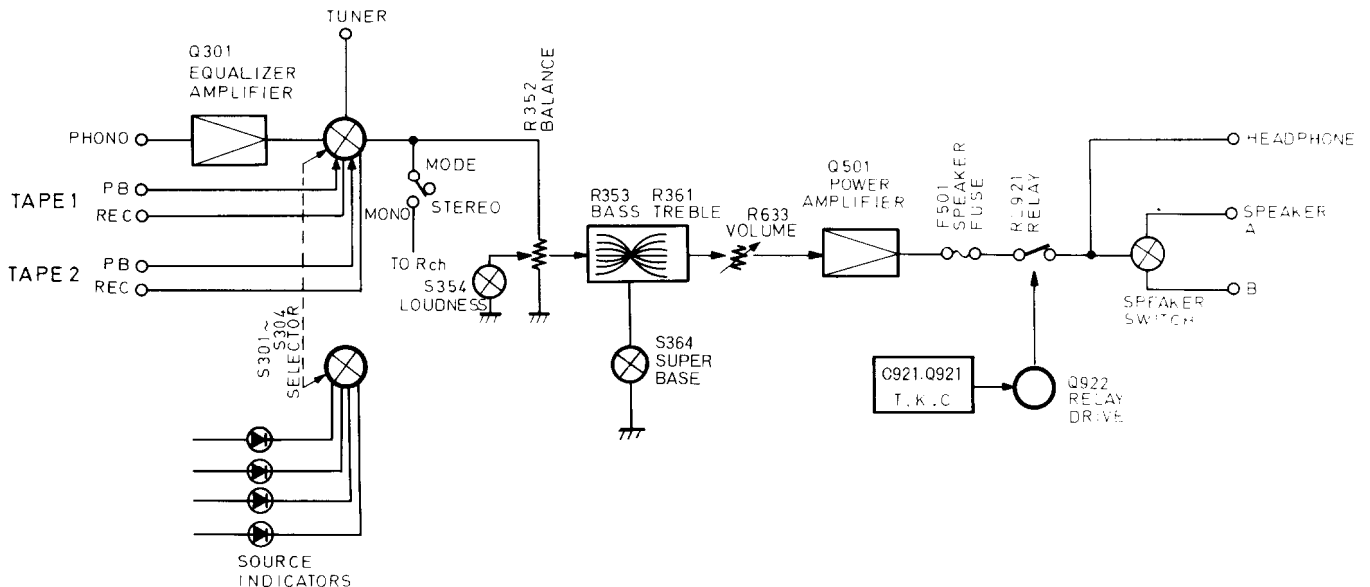

BLOCK DIAGRAM

—D model—

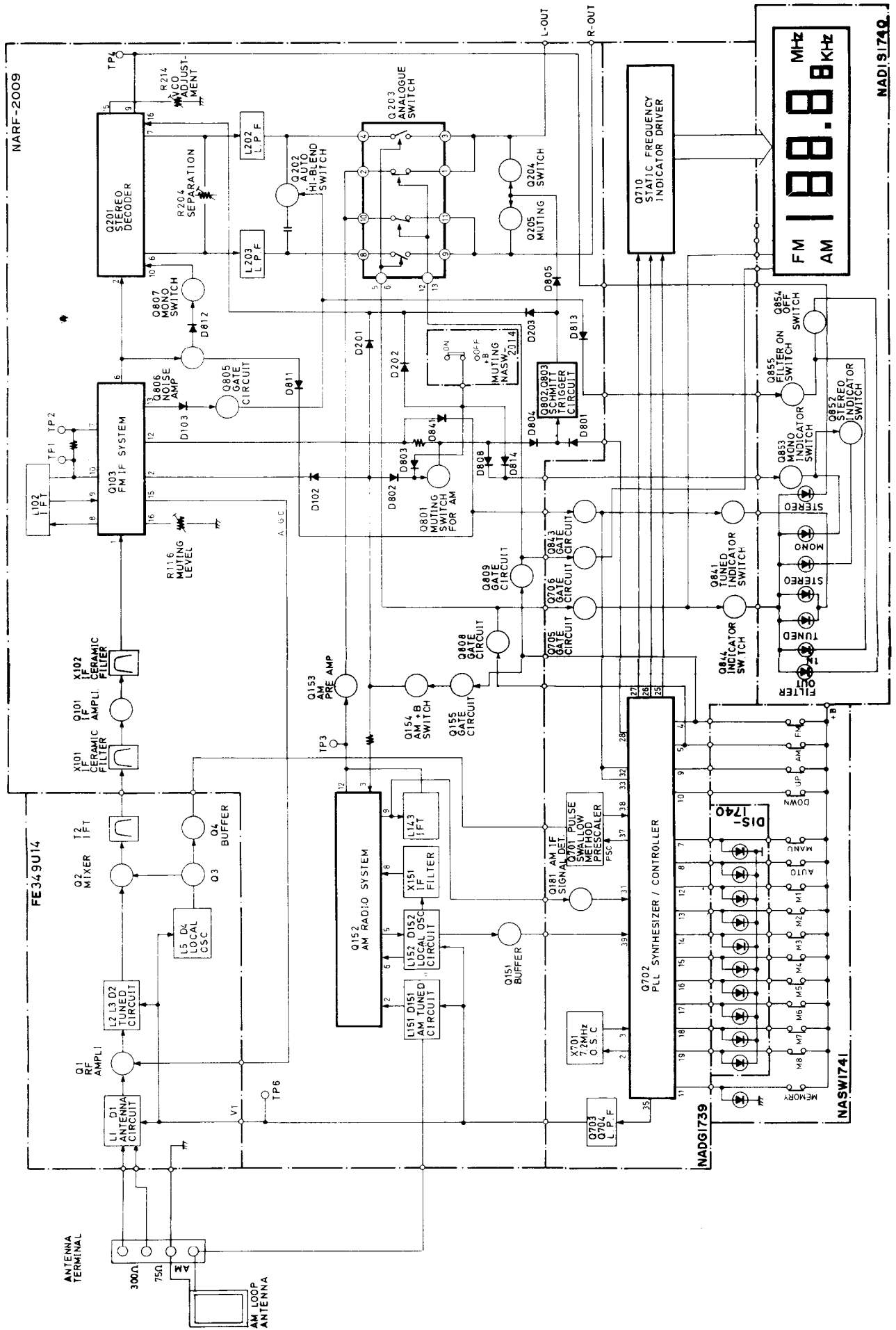

BLOCK DIAGRAM

-G model-

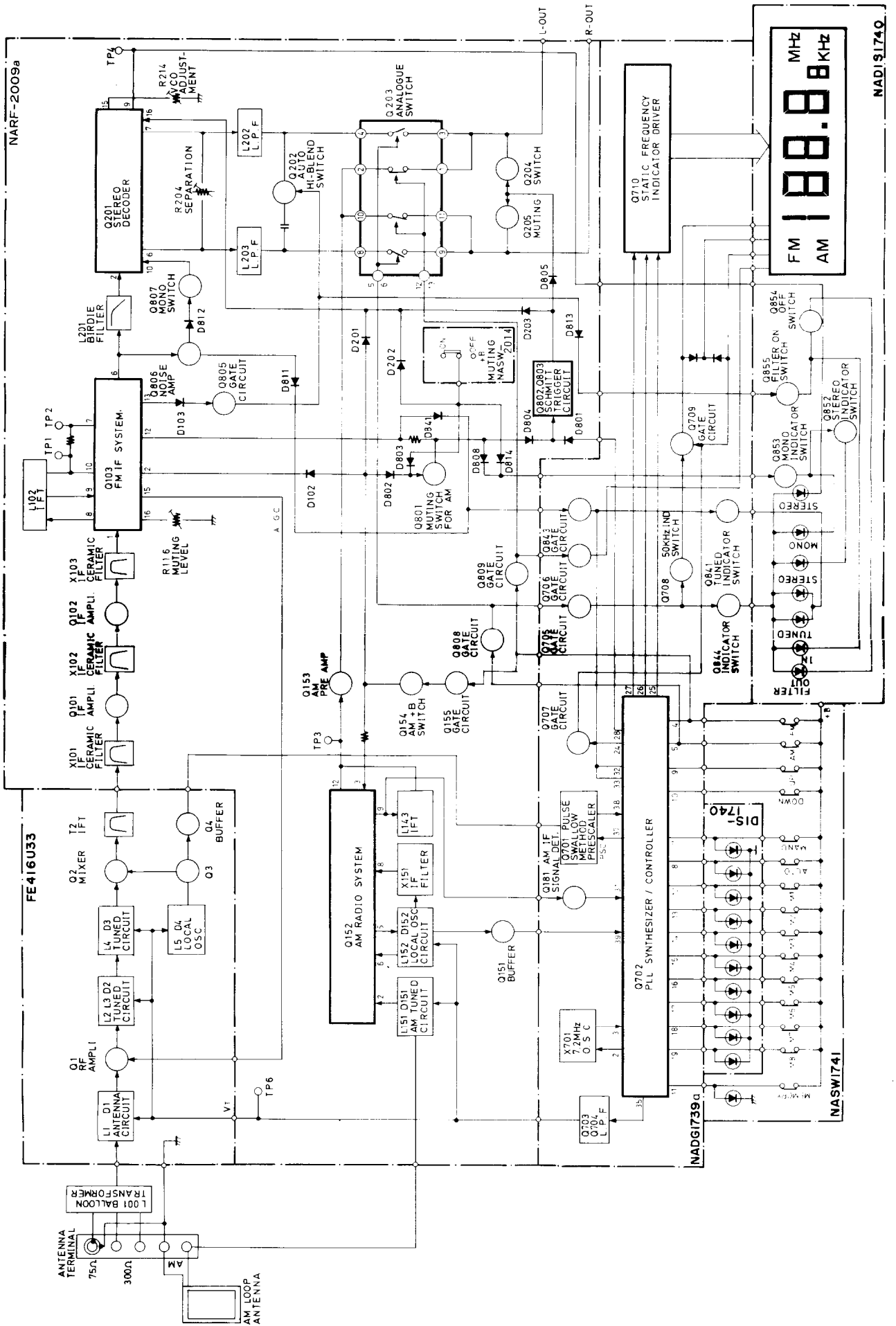

BLOCK DIAGRAM

-W model-

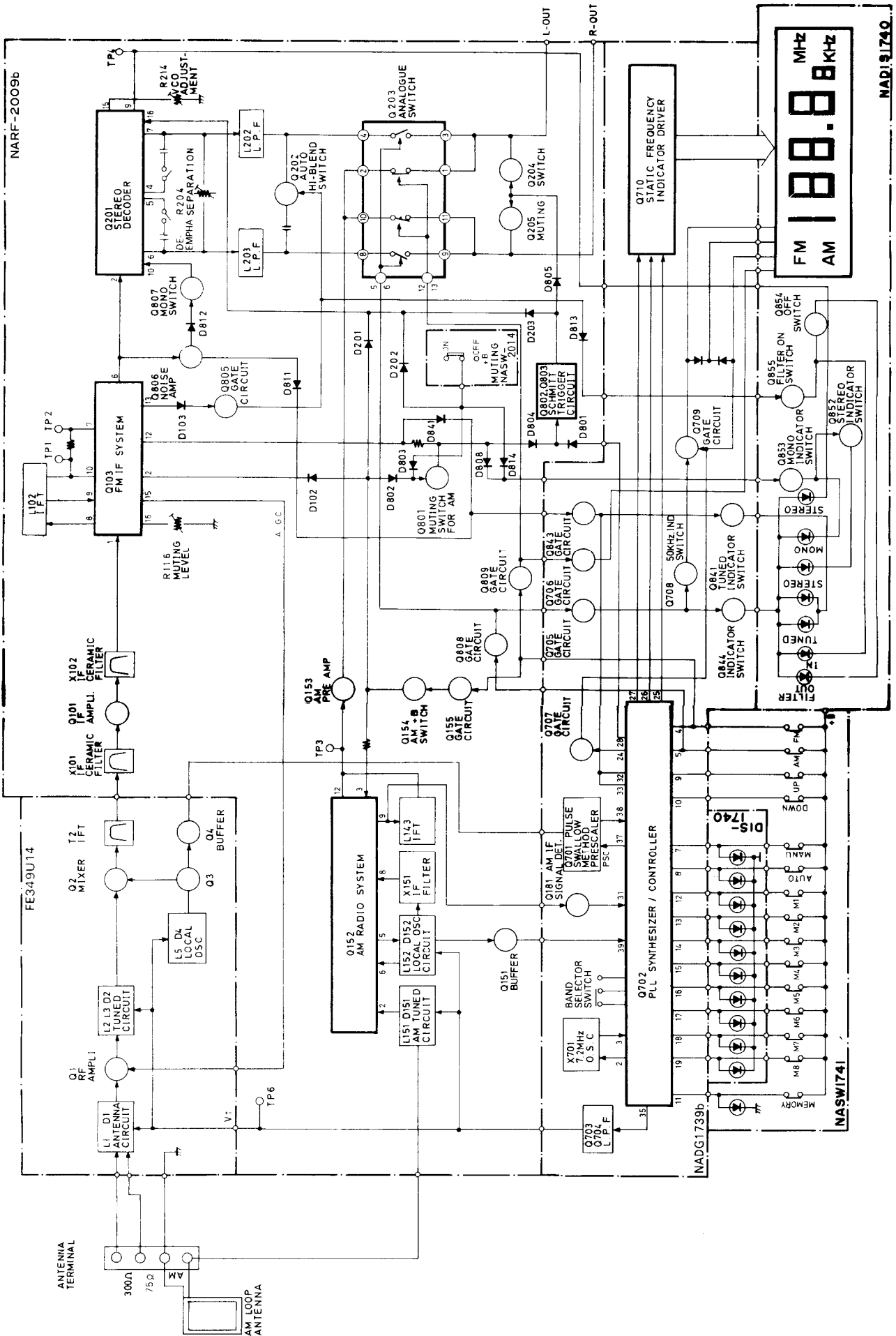

EXPLODED VIEW

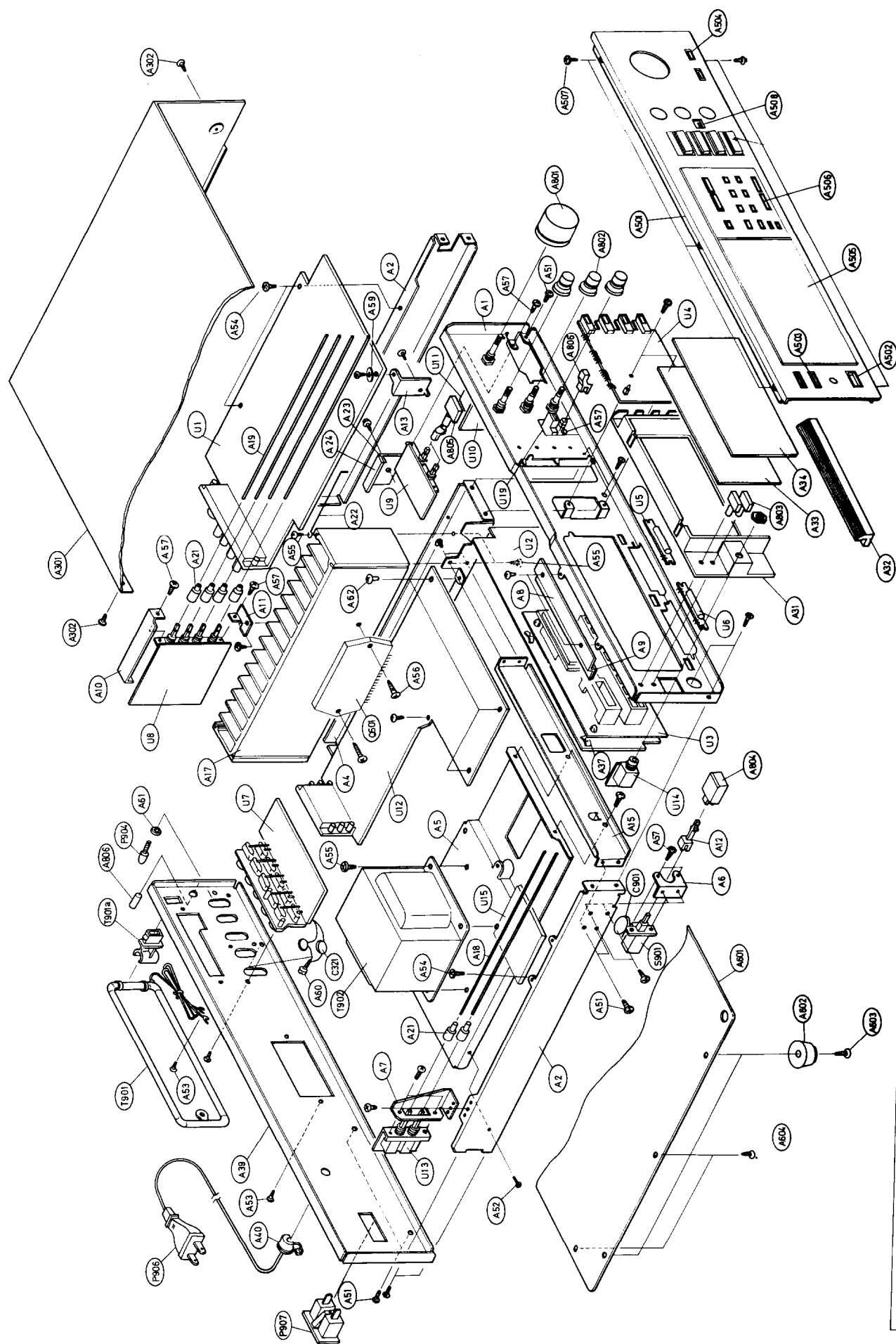

Notes: (D): Only 120V model (S): Only silver model
 (G): Only 220V model (B): Only black model
 (W): Only 120/220V model

NOTE: THE COMPONENTS IDENTIFIED BY MARK  ARE CRITICAL FOR RISK OF FIRE AND ELECTRIC SHOCK. REPLACE ONLY WITH PARTS NUMBER SPECIFIED.

PART LIST

REF. NO.	PART NO.	DESCRIPTION	REF. NO.	PART NO.	DESCRIPTION	REF. NO.	PART NO.	DESCRIPTION
A1	27110202-1A	Front bracket	A505	28198607	Clear plate	U1	18148509	NARF-2009,FM/AM
A2	27115145A	Side bracket	A506	28321584	Knob ass'y	U1	18154509A	NARF-2009a,FM/AM
A4	27130339B	Bracket,radiator	A508	27267333	Guide S	U1	18150509B	tuner pc board ass'y(G)
A5	27130340A	Bracket,power transformer	A507	834430068	3TTS+6B(BC),Tapping screw	U2	18008539	tuner pc board ass'y(W)
A6	27140805	Bracket,power	A509	29110050	Aluminium tape on the front panel	U2	18034539A	NADG-1739,Digital circuit pc board ass'y(D)
A7	27140806	Bracket,spaker	A601	27170160	Bottom board	U3	18034539A	NADG-1739a,Digital circuit pc board ass'y(G)
A8	27140807	Bracket,holder	A602	27175009A	Leg	U3	18008540	NADG-1739b,Digital circuit pc board ass'y(W)
A9	28140260	1.5×10×100mm,Cushion	A603	834430128	3TTS+12B(BC),Tapping screw	U4	18008541	NADIS-1740,Fluorescent indicator pc board ass'y
A10	27140808	Bracket,selector	A604	831430088	3TTW+8B(BC),Flapping screw	U4	18008543	NAPL-1743,Dial plate illumination lamp pc board ass'y
A11	27140809A	Bracket S	A801	28320543-1	Knob,volume (S)	U5	18008544	NAPL-1744,Dial plate illumination lamp pc board ass'y
A12	27260062	Shaft,switch	A802	28320892	Knob,volume (B)	U7	18148512	NAEQ-2012,Equalizer amplifier pc board ass'y(D/W)
A13	27140810A	Bracket,PCB	A803	28321205	Knob,balance (S)	U8	18154512A	NAEQ-2012a,Equalizer amplifier pc board ass'y(G)
A15	27130341	Bracket F	A804	28321206	Knob,balance (B)	U8	18148513	NASW-2013,Selector switch pc board ass'y
A17	27160132	Radiator	A805	28321207	Knob,push (S)	U9	18148514	NASW-2014,Mode/ loudness switch pc board ass'y
A18	27260123	Shaft	A806	28321215	Knob,push (B)	U10	18148515	NATC-2015,Tone control circuit pc board ass'y
A19	27260124	Shaft	A806	28321216	Knob,push (S)	U11	18148516	NAVR-2016,Volume control pc board ass'y
A21	28320135	Connector	A806	28321522	Knob,push (B)	U12	18148531	NAAF-2031,Power supply and power amplifier pc board ass'y(D)
A22	27300656	Spring	A806	28321523	Knob,push (S)	U12	18154531A	NAAF-2031a,Power supply and power amplifier pc board ass'y(G)
A23	27140928	Bracket PCS	△C901	3500065A	0.01μF,AC400V/125V,Capacitor IS	U13	18150531B	NAAF-2031b,Power supply and power amplifier pc board ass'y(W)
A24	28175100	Insulating plate	△C901a	27300601	Cover for C901	U14	18148533	NAHP-2033,Headphone terminal pc board ass'y
A31	27190220	Holder,pcb	C321,C322	330924730	0.047μF,50V,Ceramic capacitor (D)	U15	18154534	NAFU-2034,Fuse terminal pc board ass'y
A32	27190221	Holder,lamp	C990	335622230	0.022μF,50V,Ceramic capacitor	U16	18154510	NASW-2010,De-emphasis switch pc board ass'y(W)
A33	28133102	Back plate	△F501,F601	252059	4A(SS-2),Speaker protection fuse (D/W)	U17	18010542	NASW-1742,Band selector switch pc board ass'y(W)
A34	28130216	Dial plate	△	252076	3.15A-SE-EAK,Speaker protection fuse(G)	U19	18148517	NATS-2017,Super base switch pc board ass'y
A37	27190011	Holder	△	252076	3.15A-SE-EAK,Speaker protection fuse(G)			
A39	27120591	Back panel (D)	△C901a	27300601	Cover for C901			
	27120592	Back panel (G)	C321,C322	330924730	0.047μF,50V,Ceramic capacitor (D)			
	27120593	Back panel (W)	C990	335622230	0.022μF,50V,Ceramic capacitor			
△A40	270280	SR4K-4,Strainrelief	△F501,F601	252059	4A(SS-2),Speaker protection fuse (D/W)			
A51	834430068	3TTS+6B(BC),Tapping screw	△	252076	3.15A-SE-EAK,Speaker protection fuse(G)			
A52	838430068	3TTB+6B(BC),Tapping screw	△F901	252049	4A(ST-6),Primary fuse(D/W)			
A53	834430108	3TTS+10B(BC),Tapping screw	△F902	252074	2A-SE-EAK,Primary fuse(G/W)			
A54	831130088	3TTW+8B,Tapping screw	△F903,F904	252078	5A-SE-EAK,Secondary fuse(G)			
A55	838440089	4TTB+8C(BC),Tapping screw	△F905,F906	252070	1A-SE-EAK,Secondary fuse (G)			
A56	834430168	3TTS+16B(BC),Tapping screw	△F907	252088	250mA-SE-EAK,Secondary fuse (G)			
A57	82143006	3P+6FN(BC),Pan head screw	P904	25060044	Terminal,ground			
A61	87613010	W3×10F,Washer	△P906	253112	AS-UC-4#18,Power supply cable(D)			
A62	831430088	3TTW+8B(BC),Tapping screw	△	253083-1	AS-CEE,Power supply cord (G)			
A301	28184201	Top cover(S)	△P907	25050046	NSCT-2P15,AC outlet(D)			
A301	28184202	Top cover (B)	S908	223004-1	Terminal			
A302	834430068	3TTS+6B(BC),Tapping screw	Q501,Q601	222041	STK-4843,Power amplifier IC			
A501	18148121	Front panel ass'y (S)	△S901	25035398	NPS-111-L362P,Power switch			
A502	27267215	Guide,power	△S902	25065123	NPS-1258P,Voltage selector switch(W)			
A503	27267280	Guide,spaker	T901	232085	AM loop antenna			
A504	27267282	Guide,push	T901a	27190105	Holder,antenna			
A505	28198607	Clear plate	△T902	230787	NPT-837D,Power transformer(D)			
A506	28321583	Knob ass'y						
A508	27267333	Guide S						
A501	18168121	Front panel ass'y (B)						
A502	27267215	Guide,power						
A503	27267280	Guide,spaker						
A504	27267282	Guide,push						
A505	28198607	Clear plate						
A506	28321583	Knob ass'y						
A508	27267333	Guide S						
A501	18168121	Front panel ass'y (B)						
A502	27267215	Guide,power						
A503	27267280	Guide,spaker						
A504	27267282	Guide,push						
A505	28198607	Clear plate						
A506	28321583	Knob ass'y						
A508	27267333	Guide S						
A501	18168121	Front panel ass'y (B)						
A502	27267215	Guide,power						
A503	27267280	Guide,spaker						
A504	27267282	Guide,push						

CIRCUIT DESCRIPTIONS

1. Synthesizer and controller operation

Pin No.	Symbol	Terminal	Description
1	GND	Ground	
2	XT	X'tal	Connected to the 7.2MHz crystal oscillator for the reference frequency.
3	XT		
4	FM	FM band specification input	Mutual reset type, performs switching of each band. FM/MW/LW.
5	MW	MW band specification input	
6	LW	LW band specification input	
7	MANUAL	Manual tuning mode specification input	Mutual reset type, performs auto search and manual operation mode switching during UP/DOWN tuning.
8	AUTO	Auto search tuning mode specification input	
9	UP	UP tuning key input	Connect the push key and perform UP/DOWN tuning.
10	DOWN	DOWN tuning key input	
11	STO	Memory store command input	The preset memory is set to the write mode when the key is pressed.
12-19	M1-M8	Preset memory channel specification input	Controls the write and read out of the internal 16-station preset memory along with the MC1 and MC2 input.
20	MC-1	Memory control input	Set the 16-station preset memory to the 8 FM/8 AM station mode or the FM/MW/LW 3-band 16-station random mode. The 8 FM/8 AM mode is used in this unit.
21	MC-2		
22	OSC2	AM oscillator terminal	CR connection terminal for the oscillator that determines the scan speed during the AM search mode.
23	OSC1	FM oscillator terminal	CR connection terminal for the oscillator that determines the scan speed during the FM search mode.
24	O/5	FM 50 kHz output	Output that represents the 50kHz FM band tuning step for European models. Goes to the high level for the 50 kHz setting.
25	CK2	Tuned frequency data output	Outputs the serial data and timing clock to the tuned frequency display driver.
26	CK1		
27	DATA		
28	MUTE	Muting signal output	Goes to the high level during muting output.
29	E2	Regin specification input	See table 1.
30	E1		
31	STOP 3	AM IF signal input	During AM reception, this counts the IF signal and stops auto search.
32	STOP 2	Auto search stop signal input	When the stop 1 input (pin 33) is at the high level and this terminal goes to the high level, auto search is stopped.
33	STOP 1	Scan speed slow input	When the high level is input at this terminal, the auto search speed is cut in half.

Pin No.	Symbol	Terminal	Description
34	DO1	Error output	Charge pump output of the phase detector which constitutes the PLL. High level is output when the divided oscillation frequency is high than the reference frequency. In the opposite case, low level is output. Floating occurs when the frequencies match. The output is applied to the variable capacitor diode in the front end through low pass filter Q703 and Q704. The output from both terminals is the same, but only DO1 is used.
35	DO2		
36	TEST	Test terminal	Test mode at the high level.
37	FM IN	FM programmable counter input	Connect to the prescaler output (Pin3 of Q701)
38	PSC	Pulse swallow control output	Output to the control the division ratio of the prescaler.
39	AM IN	AM local oscillator signal input	Terminal for input of AM broadcast signal.
40	$\overline{\text{INH}}$	Inhibit input	Operates normally at the high level. Inhibit status at the low level.
41	$\overline{\text{INT}}$	Initialize input	Operates normally at the high level. At the low level, the internal status is initialized.
42	V _{DD}	Power supply	Device power terminal; supplies 5V during the normal operation and 2.5V from the super capacitor (C715) for memory preservation.

table 1.

E1 (Pin 30)	E2 (Pin 29)	Regin	Band	Frequency range	Intermediate frequency	Scan step	Reference frequency
0	1	U.S.A	FM	87.5 ~ 108.0 MHz	+10.7 MHz	100 kHz	25 kHz
			AM1	520 ~ 1 710 kHz	+450 kHz	10kHz	10 kHz
1	1	Europe	AM2	522 ~ 1 710 kHz	+450 kHz	9kHz	9kHz
1	0		FM	87.50 ~ 108.00 MHz	+10.7 MHz	50 kHz	25 kHz
			MW	522 ~ 1611 kHz	+450 kHz	9 kHz	9 kHz
0	0	Japan	LM	153 ~ 360 kHz	+450 kHz	1 kHz	1 kHz
			FM	76.0 ~ 90.0 MHz	-10.7 MHz	100 kHz	25 kHz
0	0	Japan	AM	522 ~ 1611 kHz	+450 kHz	9 kHz	9 kHz

2. Auto-Hi-blend circuit

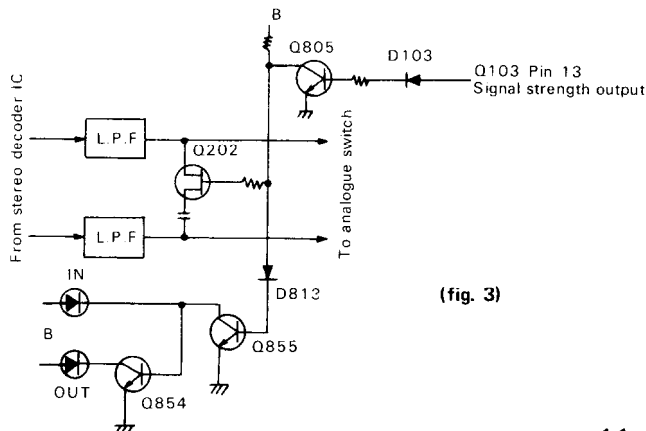

(fig. 3)

There is a 3-stage IF level detection circuit in the IC of Q103. A direct current voltage approximately proportional to the electrical field intensity is output from output pin 13. This is used to turn off Q805 and turn on Q202 when the electrical field is weak and, making use of the fact that the phase of noise components in the high range of stereo broadcasts is reversed left-right, the left and right channels are mixed in the high range to reduce noise. At the same time, Q855 is turned on and Q854 is turned off, and the IN LED of filter lights on.

3. Auto-search tuning circuit

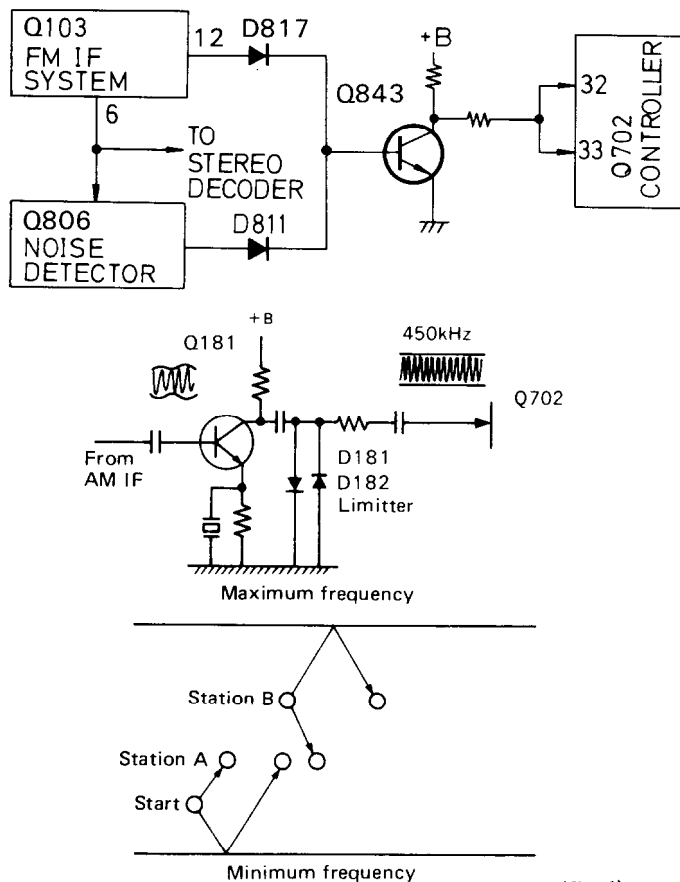

(fig. 4)

4. FM/AM selector circuit

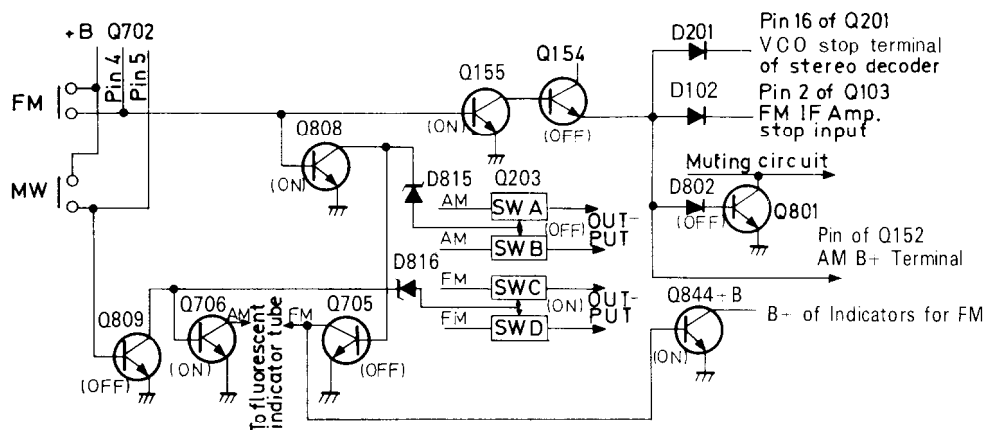

(fig. 5)

The FM/AM selector circuit is shown in the diagram, fig. 5. Pins 4 and 5 of Q702 are of the mutual reset type. For FM, pin 4 is high and pin 5 is low; for AM, pin 4 is low and pin 5 is high. Because pin 5 is high and pin 4 is low during AM reception, Q809 is on and Q808 is off, the analogue switches SW1 and SW2 of Q203 are on while SW3 and SW4 are off, so an AM signal is output. Also, since Q706 goes to on and Q705 to off, the AM, kHz segments of the fluorescent display are turned on. Q844 goes to off so the FM indicators is turned off. At the same time, Q155 is turned

During FM reception, this is operated by the IF level detection and zero point detection circuits included in the FM IF system IC of Q103 and by the noise component detection circuit of Q806. When a station is tuned, the output of all outputs go to the low level so Q843 goes from on to off, causing pins 32 and 33 of the controller IC to go to the high level to complete auto search tuning.

During AM reception, the AM IF signal is taken, amplified by Q181, limited to a certain amplitude by the D181 D182 limiter circuits and auto search tuning is completed when the IF signal becomes 450 ± 3 kHz.

- **Manual Tuning**

When the UP or DOWN key is pressed, the frequency goes up or down by one step. When either key is held down, the frequency rapidly increases or decreases (scans) and stops when the key is released. When either end of the tuning range is reached, key input will no longer be received and the frequency will stop at the highest or lowest frequency.

- **Auto Tuning**

When the UP or DOWN key is pressed, scanning begins in the up or down direction, stopping where there is a radio station. Since auto scan is operated by a triangular wave, scanning is begun in the opposite direction the instant either end of the tuning range is reached. Also, if the UP or DOWN key is pressed when the tuned frequency is not at either end of the range, up or down scanning will begin.

off and Q154 turned on, so +B is supplied to the power source terminal of the radio system pin 3 of Q152.

Pin 16 of Q201 goes to the high level, the VCO oscillator stops, and pin 2 of Q103 goes to the high level so the FM IF amp is also switched off. Also, during AM reception, Q801 is turned on so the muting circuit is off. During FM reception, all of the switching transistors mentioned above perform the opposite operations to switch to the FM mode. Figures in parentheses indicate transistor operation during FM reception.

5. PLL tuned circuit

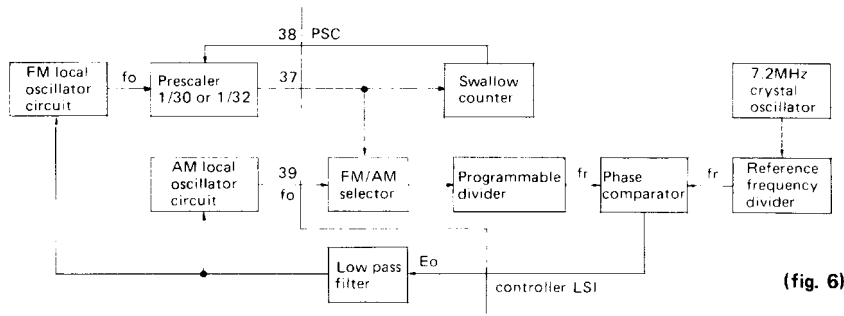

(fig. 6)

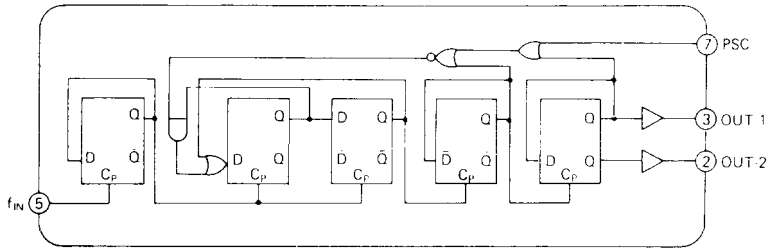

(fig 7) TD6104P (Prescaler)

A block diagram of the tuned circuit of the PLL is shown in figer 6.

Operation during AM reception

The reception frequency is applied to the programmable divider where it is divided to $1/N$ and output as f_v . This is applied to the phase comparator where it is compared with frequency reference f_r (9kHz for G/W model and 10kHz for D model). If f_r and f_v differ, E_o equal to the difference in frequency is output. Since error output E_o is a pulse waveform, it is passed through the low pass filter to change it into DC voltage V_{σ} , which is applied to the variable capacitor diode in the front end to change the reception frequency. This continues until f_v and f_r are the same and $E_o = 0$.

Operation during FM reception

The pulse swallow method is used in the prescaler of this unit. In this type of prescaler, a supplementary number

(changed according to the program code input) and the divided reception frequency from the prescaler are combined in the control counter and the prescaler's division factor is switched $1/30$ or $1/32$ according to external control ($1/32$ when the PSC terminal is "H" and $1/30$ when it is "L").

The station oscillator frequency is applied of the programmable divider, but the programmable divider has an upper frequency limit of only 30MHz, so the pulse swallow-type prescaler, which can be used up to 150 MHz, is inserted for division to $1/N_p$:

The signal is applied to the programmable divider and divided to $1/N$. The result is compared with a 25kHz frequency reference in the phase detector and the error is output as E_o until a match is obtained as in AM operation.

6. Frequency indicator circuit

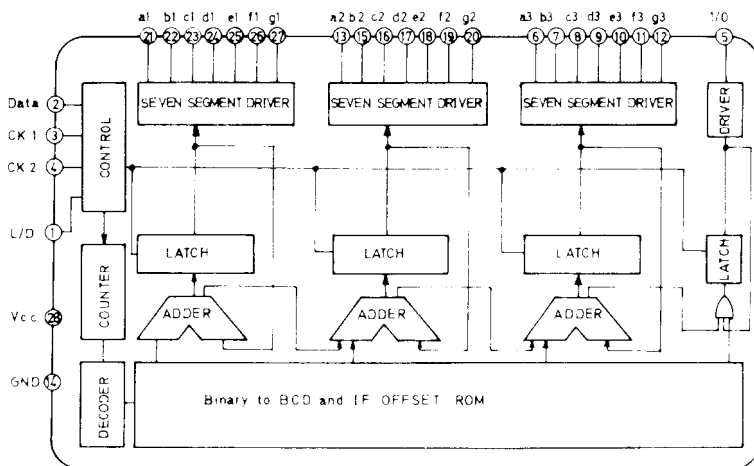

(fig. 8) TD6301AP block diagram

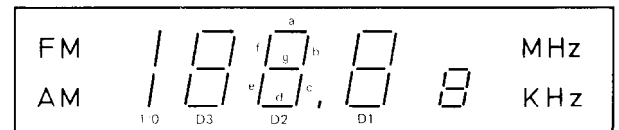

Pin No.	Terminal	Description
1	L/D	Output indication switching input terminal: Fluorescent display at the low level, and LED display at the high level.
2	Data	Tuned frequency data input terminal: Input from the system controller LSI to the serial.
3,4	CK1, CK2	Tuned frequency data input control timing input terminal: Transferred simultaneously with data from the system controller LSI.
5	1/0	Segment drive output terminal: Sets the number of display digit for FM (100MHz) and AM (1,000kHz) reception.
6-12	a3-g3	Seven segment drive output terminals: Sets the number of display digit for FM(10MHz) and AM (100kHz) reception.
13, 15-20	a2-g2	Seven segment drive output terminals: Sets the number of display digit for FM (1MHz) and AM (10kHz) reception
21-27	a1-g1	Seven segment drive output terminals; set the number of display digit for FM (100kHz) and AM (1kHz) reception
14	Vcc	Power source terminal
28	Gnd	Ground

7. Muting circuit

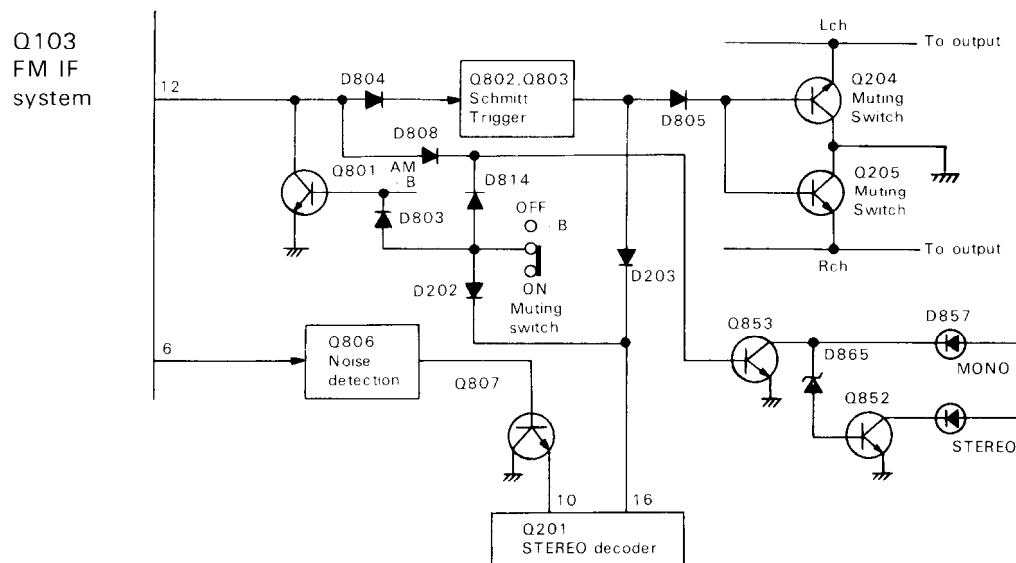

The muting circuit operates in the following cases.

1. While pin 28 of the controller IC outputs the high level, Q204 and Q205 are turned on and muting is closed in the following cases: (1) While the manual UP/DOWN switch is being held down, (2) When a station in the memory is recalled, and (3) While a radio station is being received using auto search tuning.
2. When an FM station is not being received (and the muting switch is on).

The IF level in the FM IF system (set at R116 so muting is opened at 17 dBf) and zero point detection circuit (tuning point $35 \pm 15\text{kHz}$) are output at pin 12 through

the AND circuit. When a station is tuned, the output goes to the low level.

When output goes to the low level, Q802 is turned off, Q803 is turned on and Q203 and Q204 are turned off, so muting is opened. At the same time, pin 16 of stereo decoder Q201 goes to the low level, so the VCO oscillator starts.

ADJUSTMENT PROCEDURES

FM section

Item	Step	Connection of instrument	FM SG output	Stereo modulator output	Turning dial setting	Output indicator	Adjustment	Adjust for	Remarks
FM RF	1	Fig. 1	—	—	88.0 MHz	Digital DC voltmeter	T1	1.4V	
	2	Fig. 1	107.9 MHz 1 kHz, 75 kHz devi.	—	107.9 MHz	AC voltmeter	C7, C9 (G)	Maximum output	
FM IF	1	Fig. 2	98.1 MHz 1 kHz, 75 kHz devi. 65 dBf (60 dB)	—	98.1 MHz	DC voltmeter	L101 Primary coil	0V	Repeat the steps 1 and 2 until no further adjustment is necessary
	2	Fig. 2	—	—	98.1 MHz	Distortion analyzer	L101 Secondary coil	Minimum	
VCO	1	Fig. 3	98.1 MHz No modulation 65 dBf (60 dB)	—	98.1 MHz	Frequency counter	R214	19 kHz ± 19 Hz	Remove the frequency counter after adjustment
	2	Fig. 3	98.1 MHz 65 dBf (60 dB) Ext. modulation	L ch. 1 kHz R ch. 1 kHz	98.1 MHz	R ch. AC voltmeter L ch. AC voltmeter	R204	Minimum Minimum	Maximum and same separation
Distortion	1	Fig. 3	98.1 MHz 65 dBf (60 dB) Ext. modulation	L+R 1 kHz	98.1 MHz	Distortion analyzer	T2	Minimum	
	2	Fig. 2	98.1 MHz 17.2 dBf (12 dB) 1 kHz, 75 kHz devi. 98.1 MHz 16.2 dBf (11 dB) 1 kHz, 75 kHz devi.	—	98.1 MHz	Oscilloscope	R116	Signal output No output	Muting switch to on.

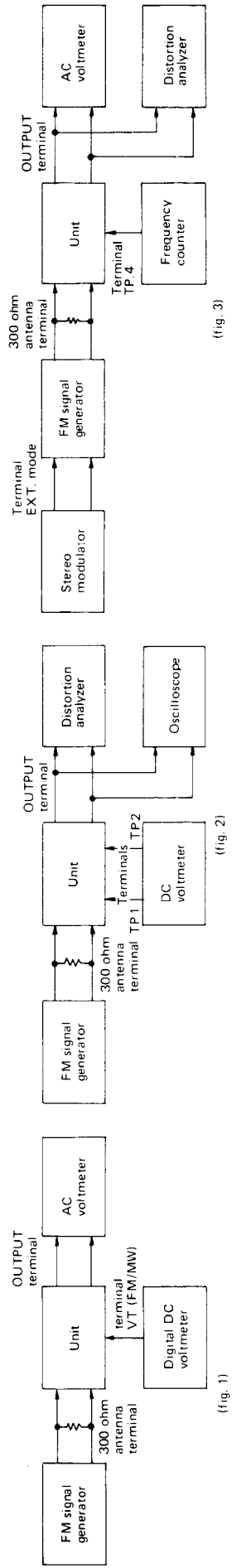

AM section

Step	AM SG output	Tuned frequency	Output indicator	Adjustment point	Adjust for	Remarks
1	999kHz (1000kHz) 400Hz 30% mod.	999kHz (1000kHz)	AC voltmeter	X151 L153	Maximum	
2		522kHz (520kHz)	Digital DC voltmeter	L152	1.2V	Repeat the steps 2 and 3 until no further adjustment is necessary.
3		1611kHz (1710kHz)	Digital DC voltmeter	C157	9.5V (10.5V)	
4	603kHz (600kHz) 400Hz 30% mod.	603kHz (600kHz)	AC voltmeter	L151	Maximum	Repeat the steps 4 and 5 until no further adjustment is necessary.
5	1404kHz (1400kHz) 400Hz 30% mod.	1404kHz (1400kHz)	AC voltmeter	C151	Maximum	

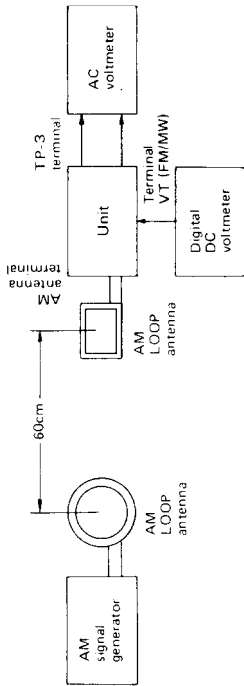

() : 120V model

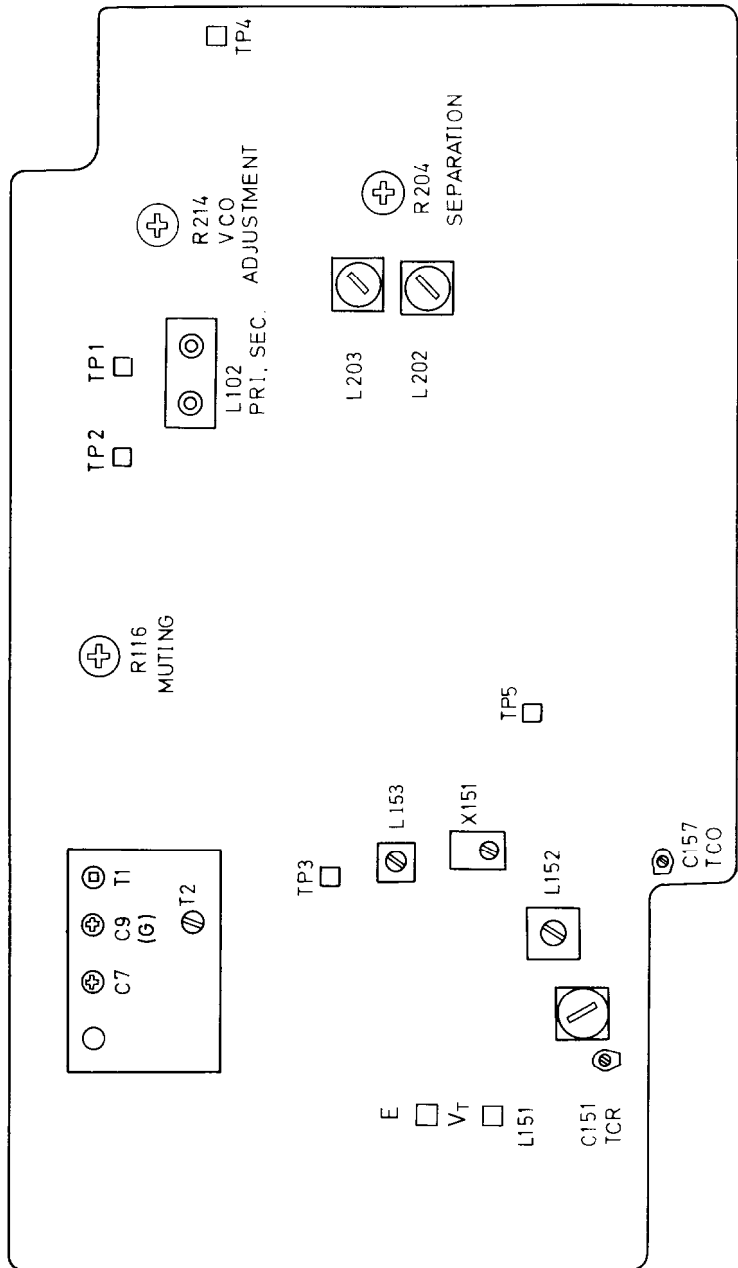

A B C D E F G

SCHEMATIC DIAGRAM

- G/Q MODELS -

- NOTES**
- * ALL RESISTORS ARE IN OHMS UNLESS OTHERWISE NOTED.
 - * ALL CAPACITORS ARE IN μ F UNLESS OTHERWISE NOTED.
 - * ELECTROLYTIC CAPACITORS ARE IN μ F/MV.
 - * VOLTAGE (MEASURED WITH V.T.V.M. INTO INPUT SIGNAL) CIRCUIT IS SUBJECT TO CHANGE FOR IMPROVEMENT.
 - * THE COMPONENTS IDENTIFIED BY MARK Δ ARE CRITICAL FOR SAFETY.

NO.	FUNCTION	POSITION
S501	POWER	ON/OFF
S101	SELECTOR	PHONO/TUNER
S102	MONITOR	SOURCE/PA
S103	MONITOR	SOURCE/PA
S104	MODE	MONITOR/STEREO
S105	LOUDNESS	ON/OFF
S106	SELECTOR	ON/OFF
S107	SPEAKERS	DIFF. B

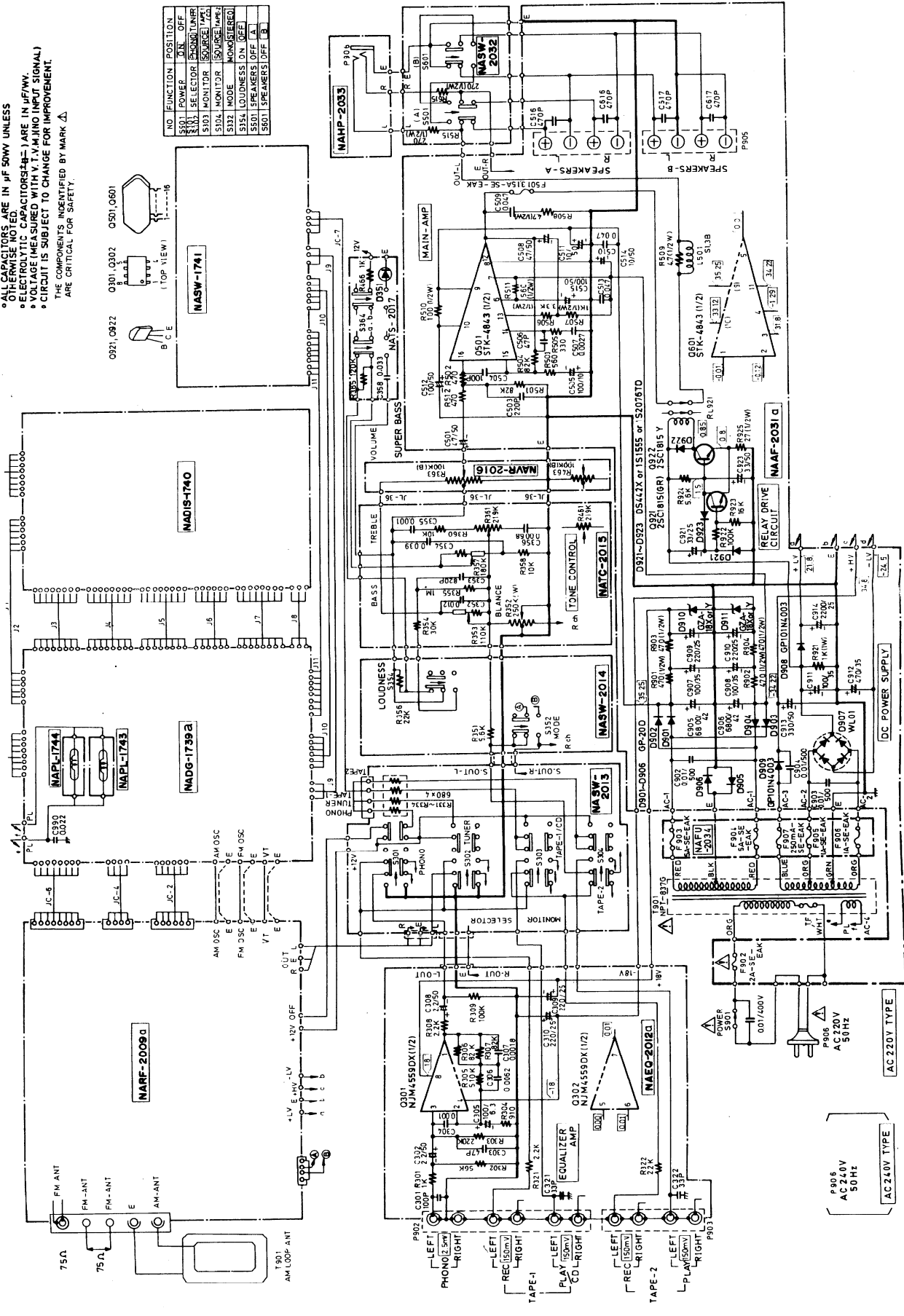

SCHEMATIC DIAGRAM

- D/W MODELS -

- NOTES
- ALL RESISTORS ARE IN OHMS UNLESS OTHERWISE NOTED
 - ALL CAPACITORS ARE IN μ F UNLESS OTHERWISE NOTED
 - ELECTROLYTIC CAPACITORS ARE IN μ F/WV
 - VOLTAGE MEASURED WITH V.T.M. (NO INPUT SIGNAL)
 - CIRCUIT IS SUBJECT TO CHANGE FOR IMPROVEMENT
- THE COMPONENTS IDENTIFIED BY MARK Δ ARE CRITICAL FOR SAFETY

NO.	FUNCTION	POSITION
3101	POWER	ON
3102	SELECTOR	FM/AM
3103	MONITOR	SOURCE
3104	MONITOR	SOURCE
3105	MODE	MONOSTEREO
3106	LOUDNESS	ON/OFF
3107	SPEAKERS	OFF/A
3108	SPEAKERS	OFF/B

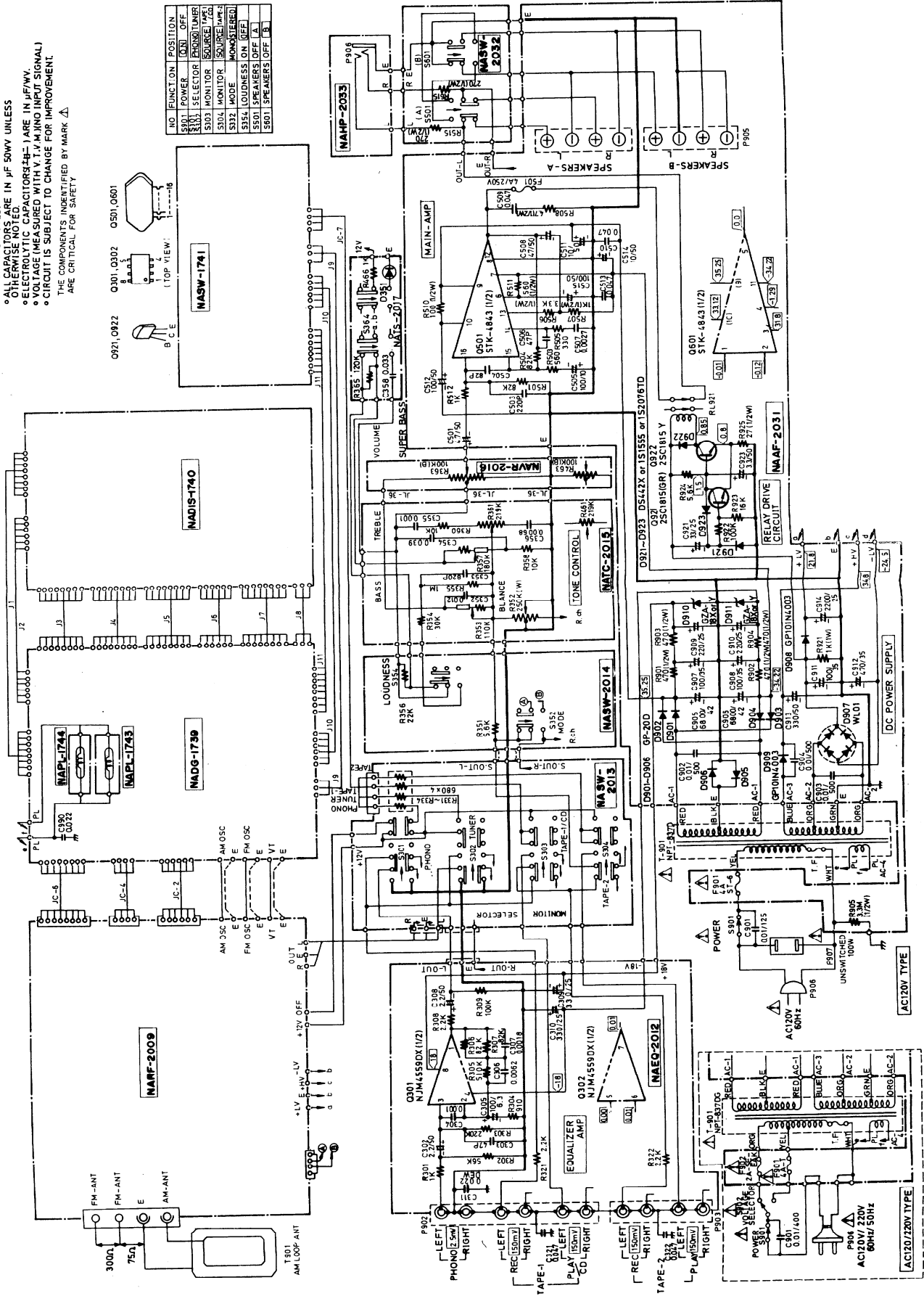

PCB PARTS LIST / VIEW FROM COMPONENT SIDE

FM/AM TUNER PCB VIEW

FM/AM TUNER PC BOARD ASS'Y (NARF-2009/a/b)

CIRCUIT NO.	PART NO.	DESCRIPTION	CIRCUIT NO.	PART NO.	DESCRIPTION
	Front end				
TU001	240061	FE349U14 (D/W)	Q153-Q155	2211254,	2SC1815(Y),
	240059	FE416U33 (G)	Q801-Q804	2211255,	2SC1815(GR),
	ICs		Q807-Q809	2210746,	2SC945A(P),
Q103	222803	μ PC1267C2 (D/ W)		2212484 or	JC501P or
	222608	μ PC1167C (G)		2212485	JC501Q
Q152	222804 or	μ PC1168C or	Q204,Q205	2211705	2SD655(E)
	222629	μ PC1243C	Q805, Q806	2211255	2SC1815(GR)
Q201	2222678	μ PC1161C3	Q951,Q953	2211255	2SC1815(GR)
Q203	222575 or	TC4066BP or		Diodes	
	222840661	40066B	D001	2243192,	MTZ8.2B,
Q952	222780122	78M12		2242866 or	EQA02-08C or
	Transistors			2239552	RD8.2EB2(G)
Q101	2211723	2SC1923(O)	D102	223105,	1S1555,
Q102	2211723	2SC1923(O) (G)	D201-D203	223133,	DS442X,
Q151,Q202	2211945 or	2SK 246(GR) or	D801-D805	223145 or	1S2076TD or
	2212304	2SK 381(D)	D808-D812	223150	US1040
			D814,D817		
			D103,D153	4000068	VD1222
			D151,D152	223140	KV1236

CIRCUIT NO.	PART NO.	DESCRIPTION
D815,D816	2241291	RD3.3EB1
D951	2239792, 2243012 or 2242741	RD27EB2, EQA02-25B or GZA27X
D952	2239433, 2243133 or 2242835	RD4.7EB3, MTZ-4.7C or EQA02-05B
D953	2239433, 2243163 or 2242848	RD6.2EB3, MTZ6.2C or EQA02-06E
Transformers		
L102	233270	NF1F-6040
L153	232095	NM1F-6025
Coils		
L001	233312	NFA-3051 (G)
L101	233105 or 233024	NCH-1005 or NCCH-1501
L151	232113	NMA-3049
L152	232084	NMO-2018
L201	233236	NMC-6027 (G)
L202,L203	233291	NMC-5039
L801	231042	NCH-2082
L802	233031	NMC-9-1
Ceramic filters		
X101,X102	3010071	SFE10.7MA5 (D/W)
X101-X103	3010043	SFE10.7MM (G)
X151	3010075	SFL450B3
Capacitors		
C108, C110	352780109	1 μ F, 50V, Elect.
C111	352784799	0.47 μ F, 50V, Elect.
C117	352741009	10 μ F, 16V, Elect.
C151, C157	3060010	NTC20P09, Trimmer
C155	370135114	510pF \pm 5%, 100V, APS
C163	352741019	100 μ F, 16V, Elect.
C167	352741009	10 μ F, 16V, Elect.
C168	352750479	4.7 μ F, 25V, Elect.
C169	352741009	10 μ F, 16V, Elect.
C174	352784799	0.47 μ F, 50V, Elect.
C202	352750479	4.7 μ F, 25V, Elect.
C208	352744719	470 μ F, 16V, Elect.
C209, C210	352741009	10 μ F, 16V, Elect.
C213	370134714	470pF \pm 5%, 100V, APS
C214	352780109	1 μ F, 50V, Elect.
C215	352780339	3.3 μ F, 50V, Elect.
C216	352782299	0.22 μ F, 50V, Elect.
C218, C219	352780109	1 μ F, 50V, Elect.
C220	352724719	470 μ F, 6.3V, Elect.
C801	352780109	1 μ F, 50V, Elect.
C802	352780229	2.2 μ F, 50V, Elect.
C806	352783399	0.33 μ F, 50V, Elect.
C809	352780229	2.2 μ F, 50V, Elect.
C951	352780109	1 μ F, 50V, Elect.
C954	352751019	100 μ F, 25V, Elect.
C956	352724719	470 μ F, 6.3V, Elect.
C958	352780109	1 μ F, 50V, Elect.
Resistors		
R116	5215003	N08HR20KBC, Semi-fixed
R204	5215048	N08HR200KBC, Semi-fixed
R214	5215044	N08HR5KBC, Semi-fixed
R952	441721204	12ohm, 2W, Metal oxide film
R955	441523904	39ohm, 1/2W, Metal oxide film
Terminal		
P901	25060082	NTM-4PDMN26, Antenna (D/W)
	25060083	NTM-5PDMN27, Antenna (G)

Note: (D): Only 120V model
(G): Only 220V model
(W): Only 120/220V model

CHANGE OF PARTS

10-24-84

MODEL TX-26

ONKYO CORPORATION
SERVICE DIVISION

TYPE	CIRCUIT NO.	DESCRIPTION	AFTER CHANGE SPECIFICATIONS		BEFORE CHANGE SPECIFICATIONS		APPLI- CATION	CHANGE DESCRIPTION
				PART NO.		PART NO.		
NARF-2009	Q103 R116 R815 R149	IC Semi-fixed Carbon Carbon	μ PC1167C N08H50KBC R25J 330K Abolition	222608 5215046	μ PC1267C N08H20KBC R25J 75K R25J 1K	222803 5215003	7536-	The supply of part is insufficiency.
NAAF-2031	C508, C608	Elect.	47 μ F, 63V	3500081	47 μ F, 50V	352784709	12136-	To flame-proof type (UL)
	PL901 PL902	Lamp pcb ass'y Lamp pcb ass'y Pilot lamp Pilot lamp Insulator plate	Abolition Abolition PL6.3V0.25A PL6.3V0.25A (Pc board)	210162 210162 28175110	NAPL-1743 NAPL-1744 Add Add Add		12136- (UL)	Change of material of pc board
NARF-2009	C801 C802	Elect. Elect.	1 μ F, 50V 0,22 μ F, 50V	352780109 352782299	0.22 μ F, 50V Add	352782299	2436-	Improvement of muting hysteresis.
	A805	Knob ass'y Knob ass'y	(Silver) (Black)	28321583A 28321584A		28321583 28321584	10841-	

DAIGAE
TX-26 UD

日付: 85/04/17

ページ: 1
EFFECTIVE
Between SN

Subs. Tute

Regular

発行日	回路番号	部品名	代替部品	正規部品	適用台数
590622	Q805, 806, 951, 953	TRANSISTOR	2SC1815BL	2SC1815GR	2436-3735
590725	Q703	TRANSISTOR	2SC1815BL	2SC1815GR	5036-6035
590712	Q704	FET	2SK68AM	2SK68M	3736-5035
590713	Q805, 806, 951, 953	TRANSISTOR	2SC1815BL	2SC1815GR	3736-5035
590924	Q103	IC	MPC1267C	MPC1167C2	10136-11635
591015	Q101	TRANSISTOR	2SC1923R	2SC19230	12136-12935
591031	D760, 854, 855, 859	LED	SEL2310G	SEL2413E	12936-14735
591031	D865, 866	LED	SEL2310G	SEL2413E	12936-14735
591113	Q703	TRANSISTOR	2SC1815BL	2SC1815GR	14736-16255
591113	Q705, 706, 841	TRANSISTOR	2SC945AQ1	JC501Q	14736-16255
591113	Q843, 853, 855	TRANSISTOR	2SC945AQ1	JC501Q	14736-16255
591112	D854, 760, 855, 859	LED	SEL2310G	SEL2413E	14736-16255
591112	D865, 866	LED	SEL2310G	SEL2413E	14736-16255
591112	Q153-155, 801-803	TRANSISTOR	2SC945AQ1	JC501Q	14736-16255
591112	Q807-Q809	TRANSISTOR	2SC945AQ1	JC501Q	14736-16255
591112	Q805, 806, 951, 953	TRANSISTOR	2SC1815BL	2SC1815GR	14736-16235
600131	D910, D911	DIODE	EQA02-17B	GZA18X/Y	20336-21135

4

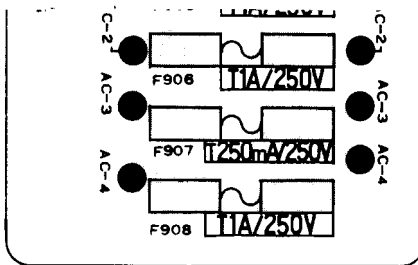
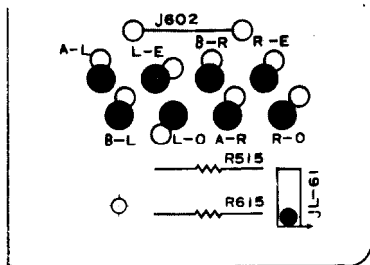

5

SPEAKER SELECTOR SWITCH PC BOARD ASS'Y (NASW-2032)

CIRCUIT NO.	PART NO.	DESCRIPTION
	Resistors	
R515, R615	441522714	270ohm, 1/2W, Metal oxide film
	Switches	
S501, S601	25035397	NPS-222-L361

HEADPHONE TERMINAL PC BOARD ASS'Y (NAHP-2033)

CIRCUIT NO.	PART NO.	DESCRIPTION
P906	25045138	HLJ0520-01-010

FUSE TERMINAL PC BOARD ASS'Y (NAFU-2034)

CIRCUIT NO.	PART NO.	DESCRIPTION
	Fuseholders	
	25050065	YSH403T
	Fuses	
△ F903, F904	252078	5A-SE-EAK
△ F905, F906	252070	1A-SE-EAK
△ F907	252088	250mA-SE-EAWK

(Only 220/240V models)

PCB PARTS LIST / VIEW FROM COMPONENT SIDE

DIGITAL CIRCUIT PCB VIEW

1

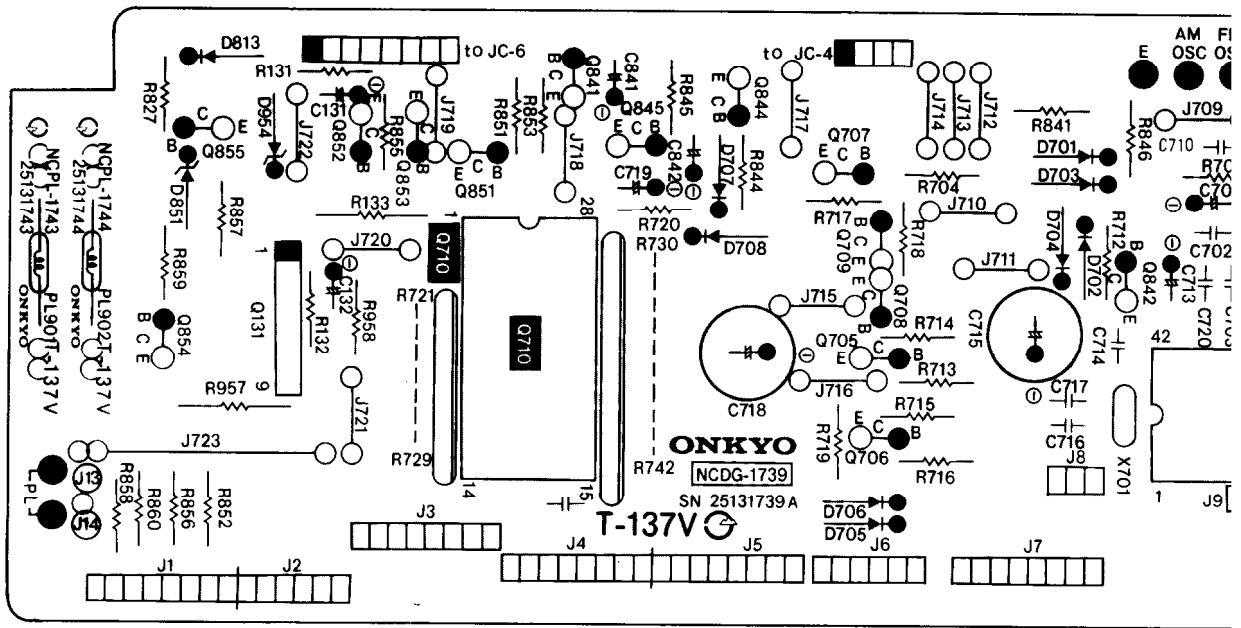

2

TUNER SWITCH PC BOARD ASS'Y (NASW-1741)

CIRCUIT NO.	PARTS NO.	DESCRIPTION
	LEDs	
D759	225126	GL3PR1
D865, D866	225137	SEL2413E
D867, D868	225142	SEL2913K
	Switches	
S751-S765	25035275	NPS-111-S239
	Spacer	
	27270103	
	Holders	
	27190224	LED

3

DE-EMPHASIS SWITCH PC BOARD ASS'Y (NASW-1737) (Only W model)

CIRCUIT NO.	PARTS NO.	DESCRIPTION
S201	250142	NSS-2225, De-emphasis switch

BAND SELECTOR SWITCH PC BOARD ASS'Y (NASW-1742) (Only W model)

CIRCUIT NO.	PARTS NO.	DESCRIPTION
S701	250142	NSS-2225, Switch

DIAL PLATE ILLUMINATION LAMP PC BOARD ASS'Y (NAPL-1743/1744)

CIRCUIT NO.	PARTS NO.	DESCRIPTION
PL901	210162	PL6. 3V0. 25A, Lamp

FLUORESCENT INDICATOR TUBE PCB VIEW

4

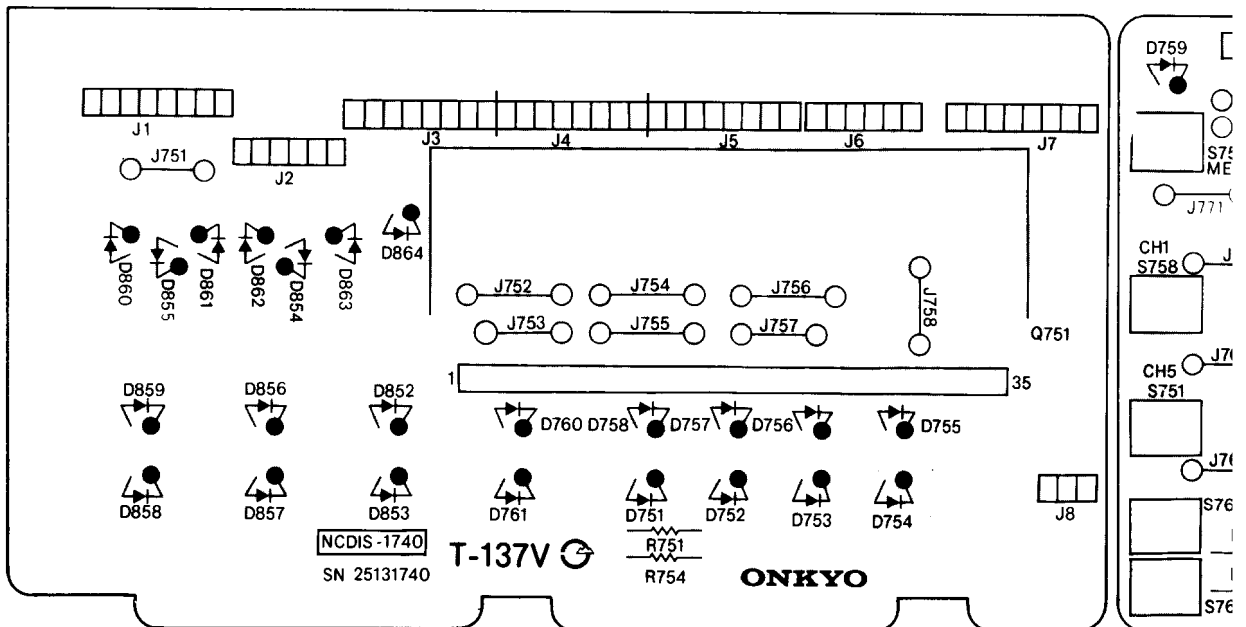

5

TUNI

Notes: (D): Only 120V model
 (G): Only 220V model
 (W): Only 120/220V model
 (Q): Only 240V model

DIGITAL CIRCUIT PC BOARD ASS'Y (NADG-1739/a/b)

CIRCUIT NO.	PARTS NO.	DESCRIPTION
ICs		
Q701	222675	TD6104P, Prescaler
Q702	222674	TC9147P, PLL synthesizer/ controller
Q710	222673	TD6301AP, Static frequency indicator driver
Transistors		
Q703	2211255	2SC1815 (GR)
Q704	2212294	2SK108 (D)
Q705, Q706	2211254	2SC1815 (Y)
Q841, Q843	2211255 or	2SC1815 (GR) or
Q853, Q855	2210746	2SC945A (P)
Q844, Q852, Q854	2211256	2SC1815 (BL)
Q707, Q708	2211255	2SC1815 (GR) (G/Q/W)
Q709	2211455	2SA1015 (GR) (G/Q/W)
Q181	2210823	2SC1675 (L-1)
Diodes		
D181, D182	223105	1S1555
D701-D704	223133 or	DS442X or
D707, D708	223145	1S2076TD
D813		
D705, D706	223105, 223133 or 223145	1S1555, DS442X or 1S2076TD (G/Q/W)
D851, D852	224178, 2241052 or 2239573	05Z9, 1Y, GZA9, 1EB3 or RD9, 1FB3
D954	2239433	RD4, 7FB3
Ceramic filter		
X181	3010076	BFU450C
X'tal		
X701	3010073	XTL-7.2M
Capacitors		
C705	352734709	47 μ F, 10V, Elect.
C706	352780109	1 μ F, 50V, Elect.
C707	352780229	2.2 μ F, 50V, Elect.
C711	395160107	1 μ F, 35V, Tantalum
C713	352784799	0.47 μ F, 50V, Elect.
C715	3020018	0.047F, 5V, Super
C718	352722229	2,200 μ F, 6.3V, Elect.
C719	352751009	10 μ F, 25V, Elect.
C841	352780339	3.3 μ F, 50V, Elect.
Resistors		
R721-R729	49121333509	33kohm \times 9, 1/8W, Network
R730-R742	49121333513	33kohm \times 13, 1/8W, Network
R957	441523904	39ohm, 1/2W, Metal oxide film

FLUORESCENT INDICATOR TUBE PC BOARD ASS'Y (NADIS-1740)

CIRCUIT NO.	PART NO.	DESCRIPTION
Fluorescent indicator tube		
Q751	212016	FIP7B8CS
LEDs		
D751-D758	225142	SEL2913K
D761		
D760, D859	225137	SEL2413F
D854, D855		
D856-D858	225142	SEL2913K
D864	225141	SEL2213C
Holders		
	27190222	LED16
	27190223	LED3
Cushion		
	28140513	

SCHEMATIC DIAGRAM

-G/Q MODELS-

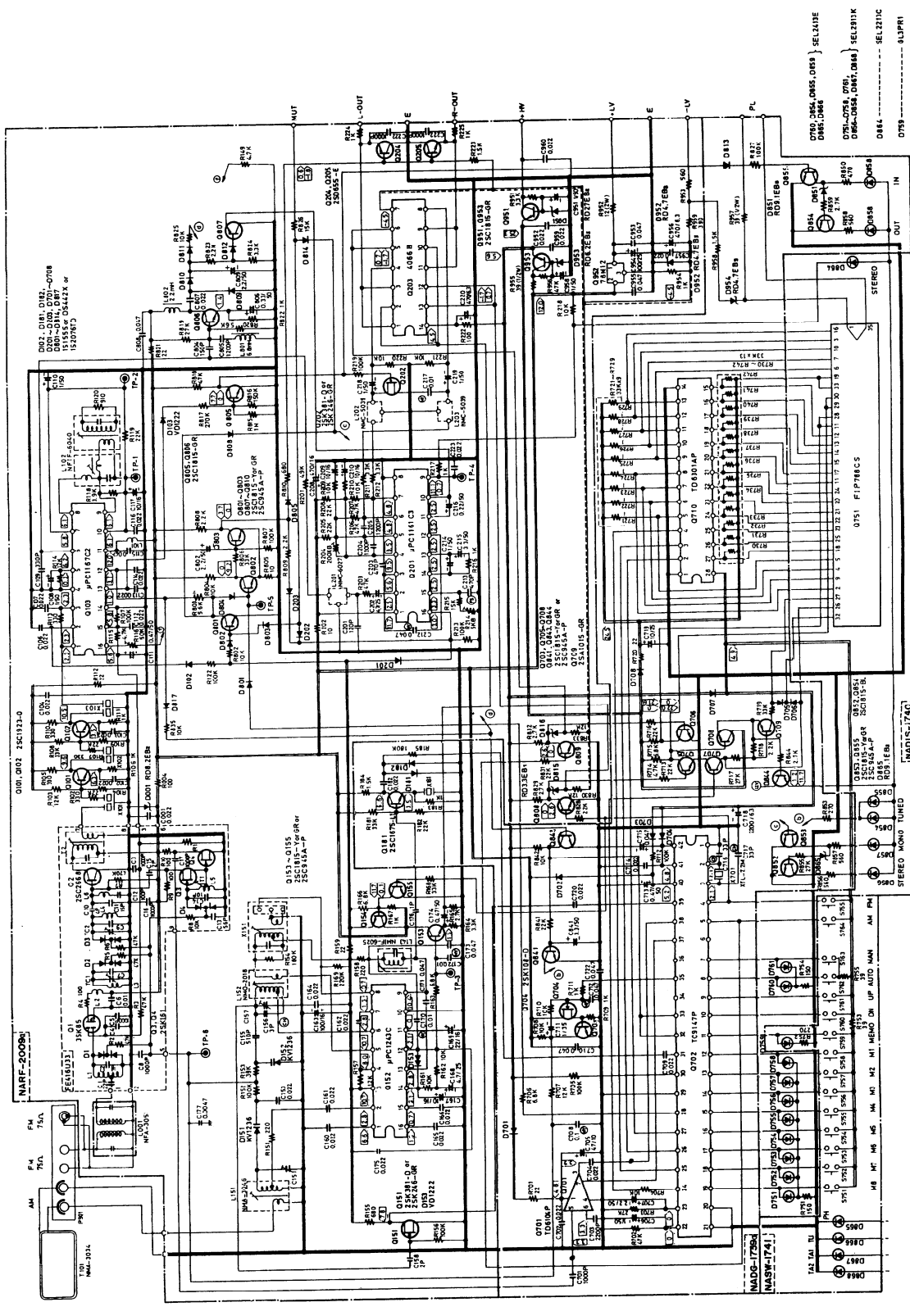

- NOTES**
- ALL RESISTORS ARE IN OHMS UNLESS OTHERWISE NOTED.
 - ALL CAPACITORS ARE IN P.F. UNLESS OTHERWISE NOTED.
 - ELECTROLYTIC CAPACITORS ARE IN μ F UNLESS OTHERWISE NOTED.
 - COMPONENTS ARE MEASURED WITH V.T.V. (NO INPUT SIGNAL).
 - CIRCUIT IS SUBJECT TO CHANGE FOR IMPROVEMENT.

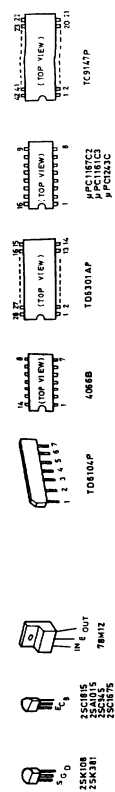
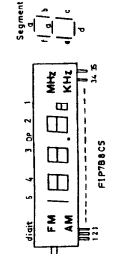

SCHEMATIC DIAGRAM

— 120V MODEL —

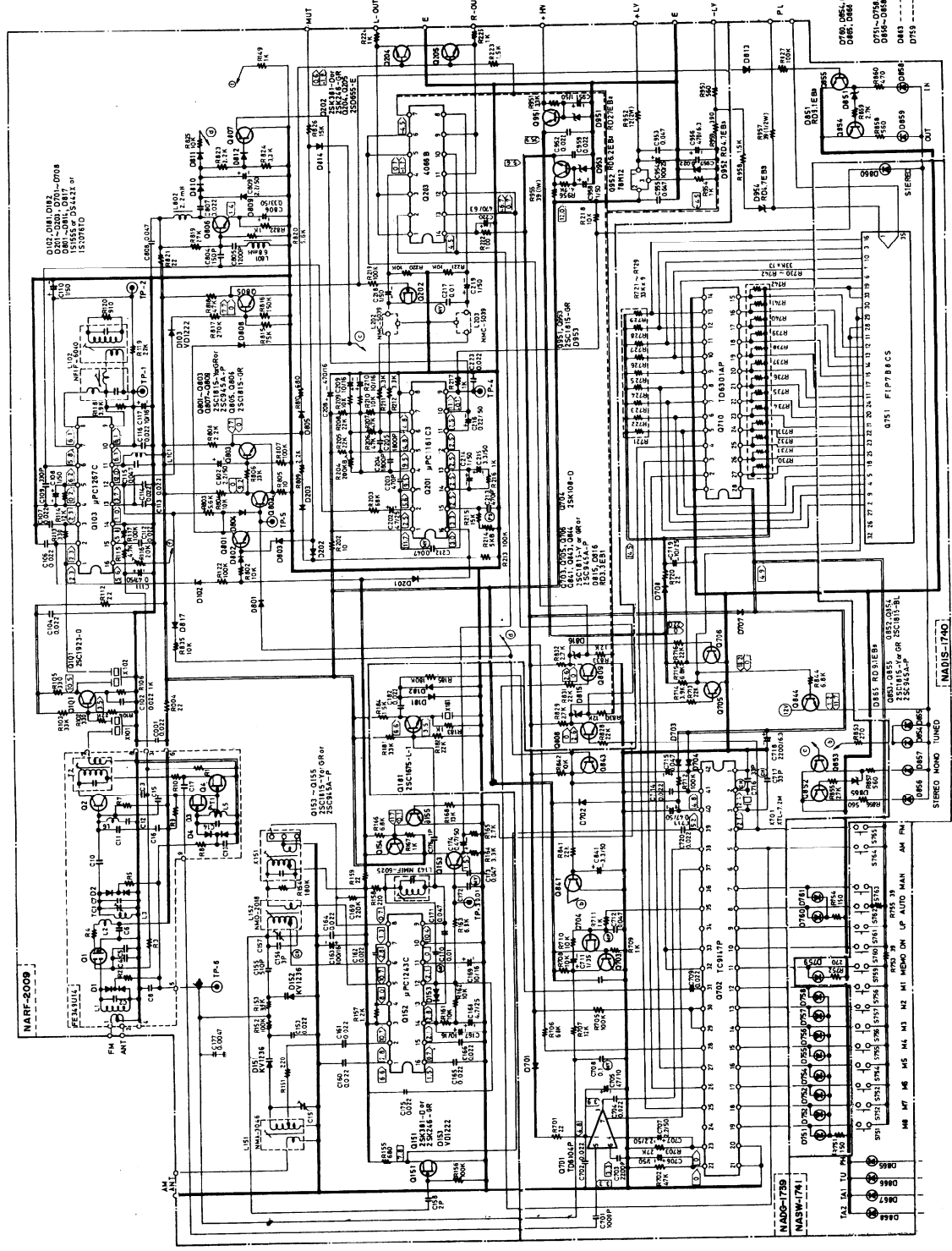

- NOTES**
- ALL RESISTORS ARE IN OHMS UNLESS OTHERWISE NOTED.
 - ALL CAPACITORS ARE IN μ F UNLESS OTHERWISE NOTED.
 - ELECTROLYTIC CAPACITORS IN μ F (NO INPUT SIGNAL)
 - VOLTAGE MEASUREMENTS AT VOLTAGE POINTS INDICATED BY "V" CIRCLES.
 - CIRCUIT IS SUBJECT TO CHANGE FOR IMPROVEMENT.

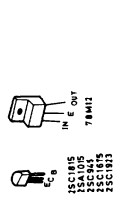
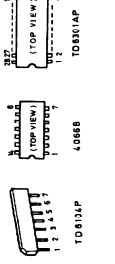
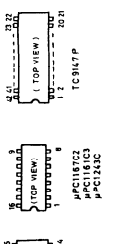
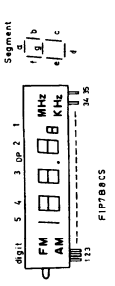

SCHEMATIC DIAGRAM

-120/220V MODEL-

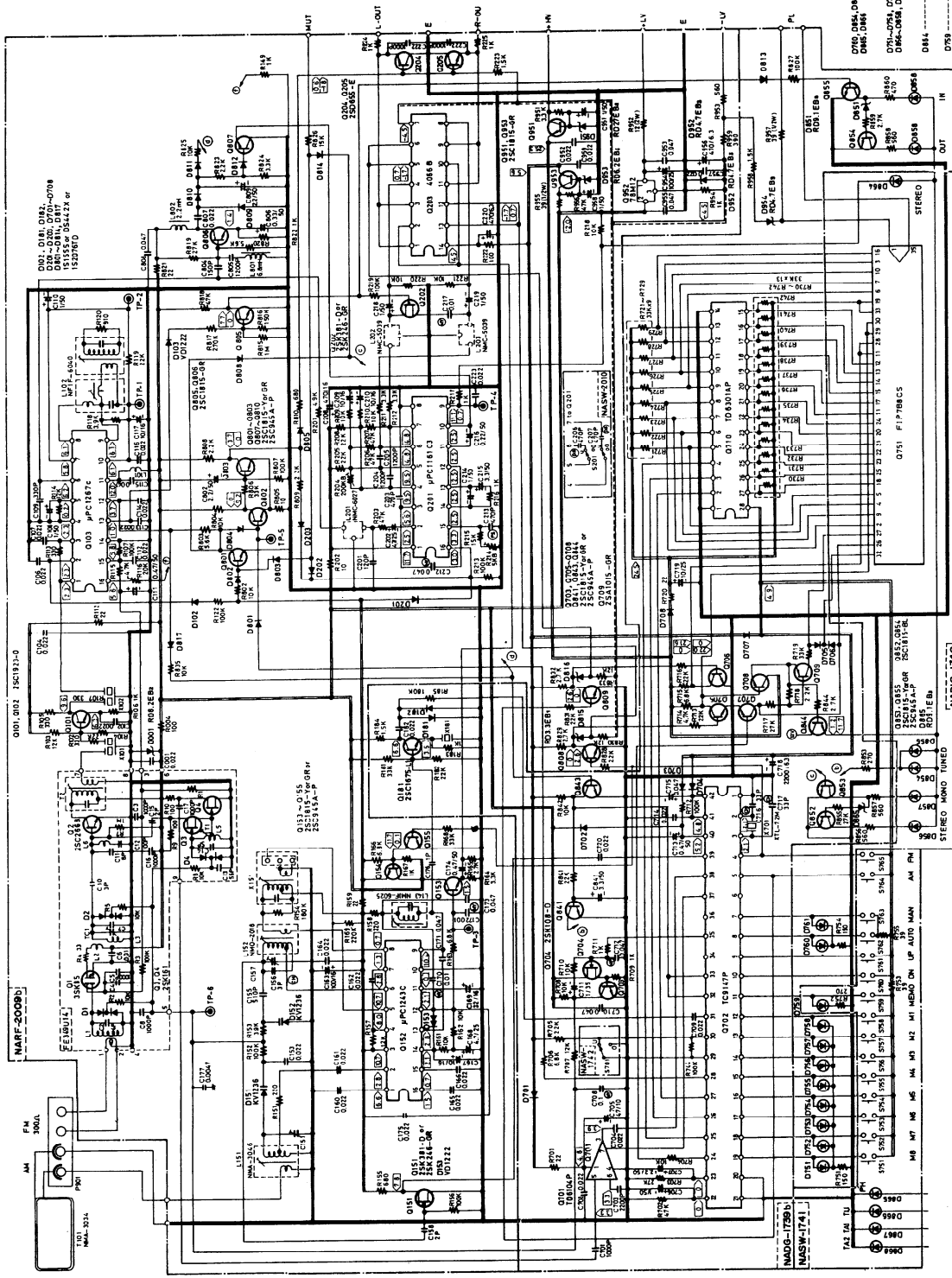

- NOTES
- ALL RESISTORS ARE IN OHMS UNLESS OTHERWISE NOTED.
 - ALL CAPACITORS ARE IN P.F. UNLESS OTHERWISE NOTED.
 - ELECTROLYTIC CAPACITORS (-E-) ARE IN MICROFARADS.
 - VOLTAGE (MEASURED WITH A.C. METER) IS SUBJECT TO CHANGE FOR IMPROVEMENT.
 - CIRCUIT IS SUBJECT TO CHANGE FOR IMPROVEMENT.

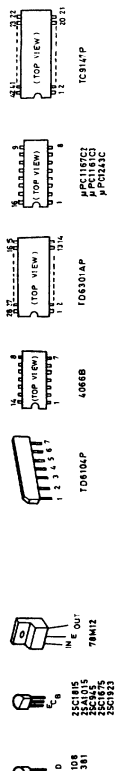
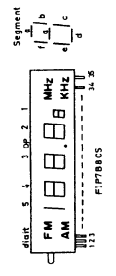

(LW)

PCB PARTS LIST/VIEW FROM COMPONENT SIDE

POWER SUPPLY AND AMPLIFIER PCB VIEW

1

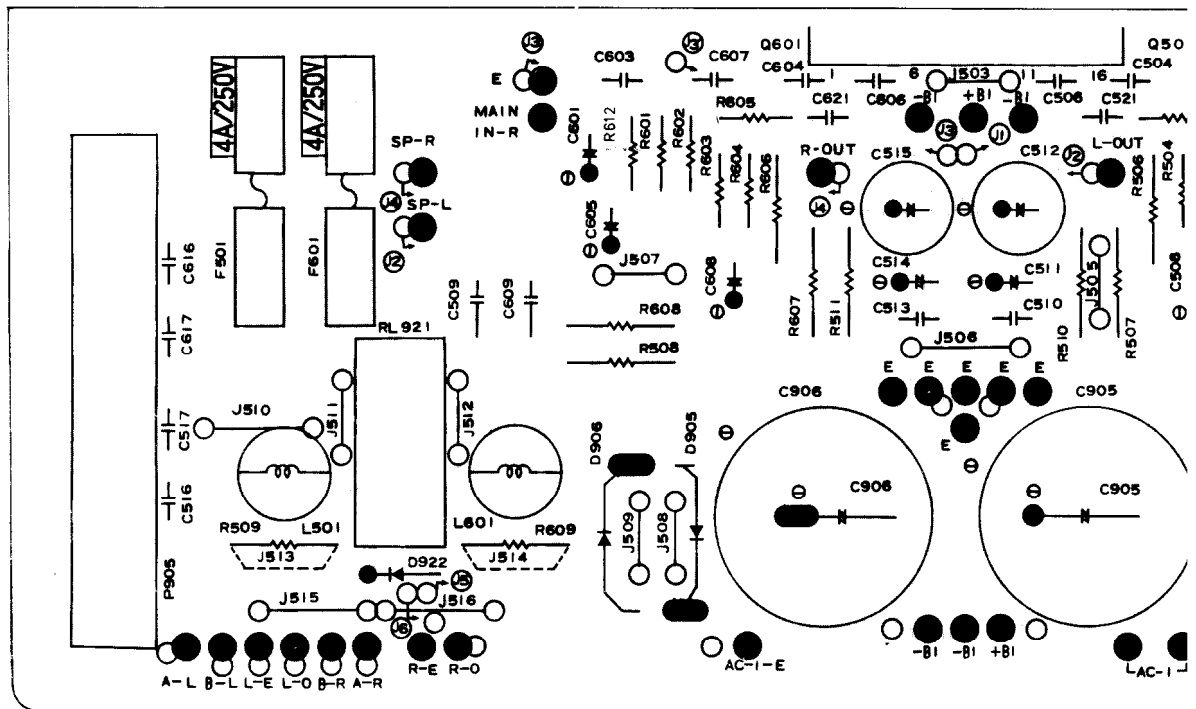

2

3

SPEAKER SELECTOR

SWITCH PCB VIEW

FUSE PCB VIEW

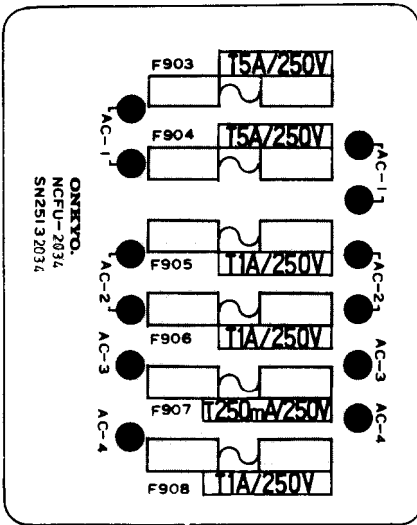
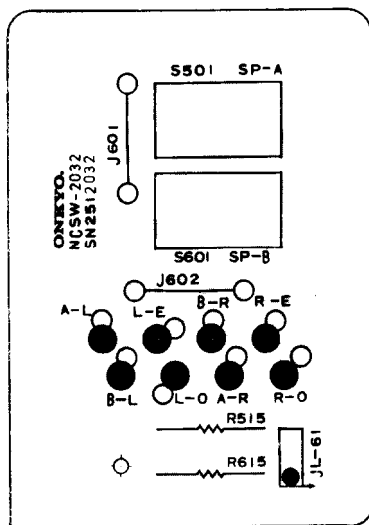

4

SPEAKER SELECTOR SWITCH PC BOARD ASS'Y (NASW-2032)

CIRCUIT NO.	PART NO.	DESCRIPTION
	Resistors	
R515, R615	441522714	270ohm, 1/2W, Metal oxide film
	Switches	
S501, S601	25035397	NPS-222-L361

HEADPHONE TERMINAL PC BOARD ASS'Y (NAHP-2033)

CIRCUIT NO.	PART NO.	DESCRIPTION
P906	25045138	HLJ0520-01-010

FUSE TERMINAL PC BOARD ASS'Y (NAFU-2034)

CIRCUIT NO.	PART NO.	DESCRIPTION
	Fuseholders	
	25050065	YSH403T
	Fuses	
△ F903, F904	252078	5A-SE-EAK
△ F905, F906	252070	1A-SE-EAK
△ F907	252088	250mA-SE-EAWK (Only 220/240V models)

5

Note: (D): Only 120V model
 (G): Only 220V model
 (W): Only 120/220V model
 (Q): Only 240V model

**POWER SUPPLY AND POWER AMPLIFIER CIRCUIT
 PC BOARD ASS'Y (NAAF-1750/a/b)**

CIRCUIT NO.	PART NO.	DESCRIPTION
		IC
Q501, Q601	222041	STK-4843, Power amplifier
		Transistors
Q921	2211255	2SC1815 (GR)
Q922	2211254	2SC1815 (Y)
		Diodes
D901-D906	223845	GP-20D
D907	223862	WL-01
D908, D909	223880	GP101N4003
D910, D911	2241191, 2241192 or 2243273	GZA-18X, GZA-18Y or MTZ-18C
D921-D923	223145, 223133, 223105 or 223150	1S2076TD, DS442X, 1S1555 or US1040
		Coils
L501, L601	231001	S1.3B (G/Q)
		Capacitors
C501, C601	352780479	4.7 μ F, 50V, Elect.
C505, C605	352731019	100 μ F, 10V, Elect.
C508, C608	352784709	47 μ F, 50V, Elect.
C511, C514	352781009	10 μ F, 50V, Elect.
C512, C515	352781019	100 μ F, 50V, Elect.
C905, C906	3504177	6,800 μ F, 42V, Elect.
C907, C908	352761019	100 μ F, 35V, Elect.
C909, C910	352752219	220 μ F, 25V, Elect.
C911	352761019	100 μ F, 35V, Elect.
C912	352764719	470 μ F, 35V, Elect.
C913	352783319	330 μ F, 50V, Elect.
C914	352752229	2,200 μ F, 25V, Elect.
C921	352753309	33 μ F, 25V, Elect.
C923	352780339	3.3 μ F, 50V, Elect.
		Resistors
R506, R606	441523324	3.3kohm, 1/2W, Metal oxide film
R507, R607	441521024	1kohm, 1/2W, Metal oxide film
R508, R608	441520474	4.7ohm, 1/2W, Metal oxide film
R509, R609	441520474	4.7ohm, 1/2W, Metal oxide film (G/Q)
R510	441521014	100ohm, 1/2W, Metal oxide film
R511	441525614	560ohm, 1/2W, Metal oxide film
R901-R904	441524714	470ohm, 1/2W, Metal oxide film
R905	431523355	3.3Mohm, 1/2W, Solid (D)
R921	441621024	1kohm, 1W, Metal oxide film
R925	441522704	27ohm, 1/2W, Metal oxide film
		Relay
RL921	25065108	NRL-2P3A-DC24-05
		Terminal
P905	25060058	NTM-8PDML25, Speaker
		Fuseholders
F901a, F501a F601a	250113	SN5051 (D/W)
F902a	25050065	YSH403T (G/Q/W)
F501a, F601a	25050065	YSH403T (G/Q)
		Fuses
F501, F601	252059	4A (SS-2), Speaker (D/W)
	252076	3.15A-SE-EAK, Speaker (G/Q)
F901	252049	4A (ST-6), Primary (D/W)
F902	252074	2A-SE-EAK, Primary (G/Q/W)

NOTE: THE COMPONENTS IDENTIFIED BY MARK Δ ARE CRITICAL FOR RISK OF FIRE AND ELECTRIC SHOCK. REPLACE ONLY WITH PARTS NUMBER SPECIFIED.

PCB PARTS LIST/VIEW FROM COMPONENT SIDE

EQUALIZER AMPLIFIER PCB VIEW

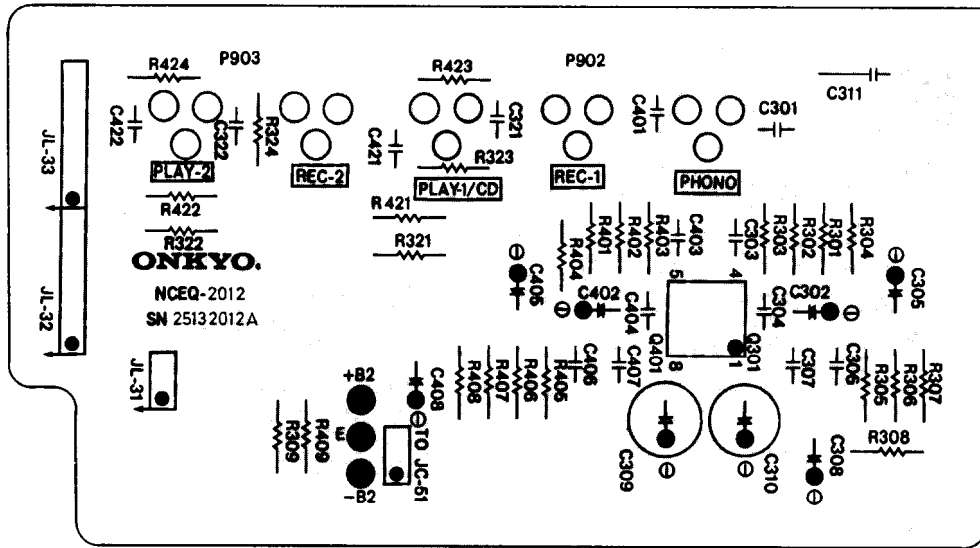

EQUALIZER AMPLIFIER PC BOARD ASS'Y (NAEQ-2012/a)

CIRCUIT NO.	PART NO.	DESCRIPTION
	IC	
Q301, Q401	222534	NJM-4559DX
	222502 or	NJM-4558DX or
	222570	NJM-4560DX
	Capacitors	
C302, C402	352780229	2.2μF, 50V, Elect.
C305, C405	352721019	100μF, 6.3V, Elect.
C308, C408	352780229	2.2μF, 50V, Elect.
C309, C310	352752219	220μF, 25V, Elect.
	Terminals	
P902	25045137	NPJ-6PDBL52, Phono/Tape 1
P903	25045084	NPJ-4PDBL42, Tape 2

BLOCK DIAGRAM

STK-4843 (Power amplifier)

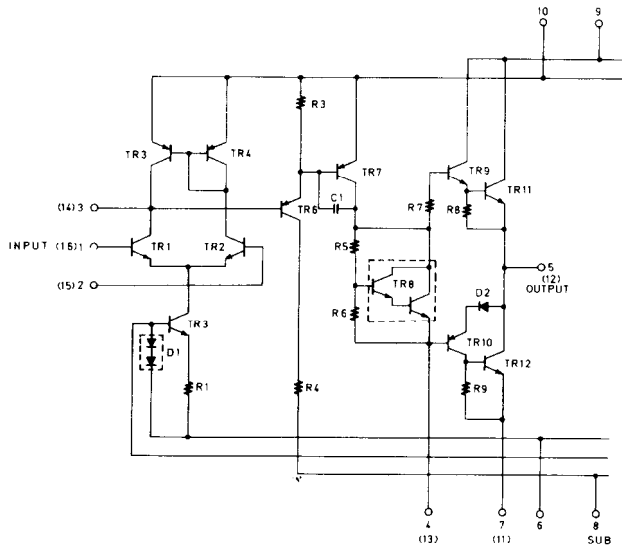

NJM-4559DX (Equalizer amplifier)

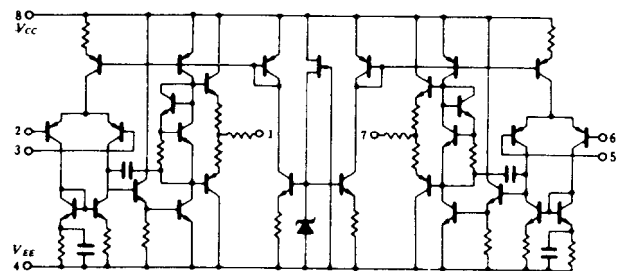

TONE CONTROL PCB VIEW

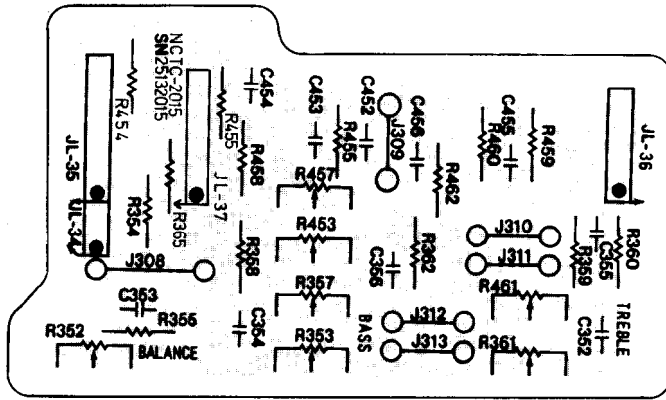

VOLUME CONTROL PCB VIEW

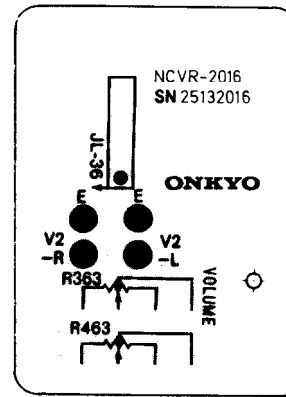

TONE CONTROL CIRCUIT PC BOARD ASS'Y (NATC-2015)

CIRCUIT NO.	PART NO.	DESCRIPTION
	Variable resistors	
R352	5146034	N16RLC250KWT30, Balance
R353, R453	5148073	N16RQMC110K180K30, Bass
R357, R457		
R361, R461	5148074	N16RGM219K30, Treble

VOLUME CONTROL PC BOARD ASS'Y (NAVR-2016)

CIRCUIT NO.	PART NO.	DESCRIPTION
R363, R463	5148093	N16RGM100KBT35, Variable resistor

SELECTOR SWITCH PCB VIEW

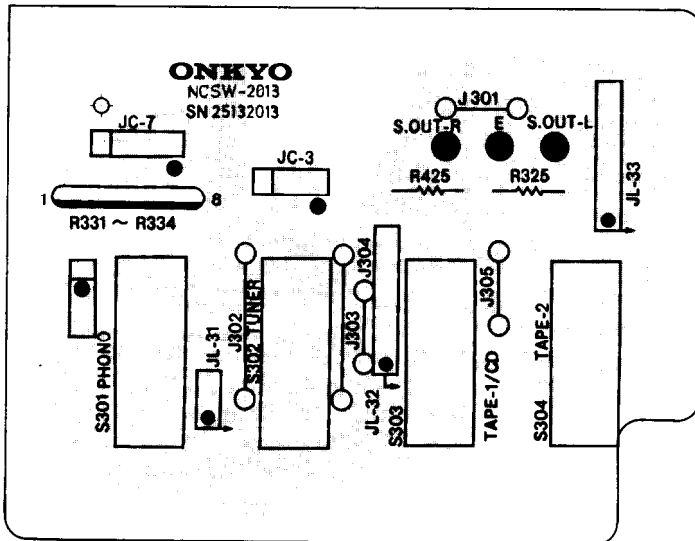

SELECTOR SWITCH PC BOARD ASS'Y (NASW-2013)

CIRCUIT NO.	PART NO.	DESCRIPTION
	Resistor	
R331-R334	49241681504	680ohmx4, 1/4W, Network
	Switches	
S301-S304	25035395	NPS-442-L358, Push

MODE/LOUDNESS SWITCH PCB VIEW

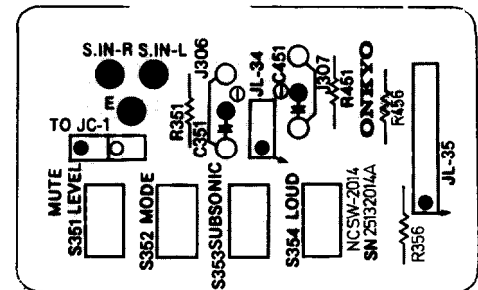

MODE/LOUDNESS SWITCH PC BOARD ASS'Y (NASW-2014)

CIRCUIT NO.	PART NO.	DESCRIPTION
S352, S354	25035396	NPS-222-L359, Push switch

SUPER BASE PC BOARD ASS'Y (NATS-2017)

CIRCUIT NO.	PART NO.	DESCRIPTION
D351	225141	SEL2213C, LED
S364	25035422	NPS-142-L386, Push SWITCH
	27190273	Holder, LED

BLOCK DIAGRAM OF IC

μ PC1267C/ μ PC1167C2 (FM IF system)

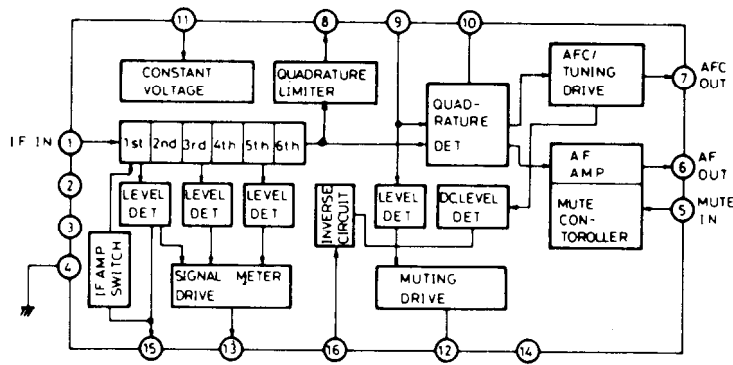

1. IF signal input
2. IF amplifier switch in; H level: Off
3. Muting switch input
4. Composite signal out
5. AFC output
6. IF amplifier output
7. 10.7MHz input
8. Reference voltage
9. Power supply
10. Muting output
11. Tuned: L level
12. Signal strength output
13. AGC output
14. Muting level

μ PC1243C/ μ PC1168C (AM radio system)

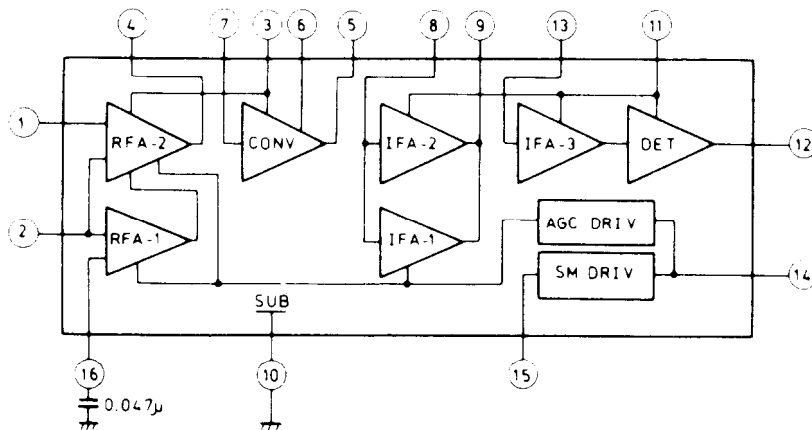

TC4066BP (Analogue switch)

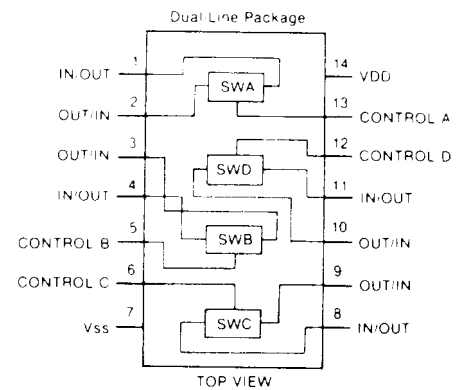

μ PC1161C3 (Stereo decoder)

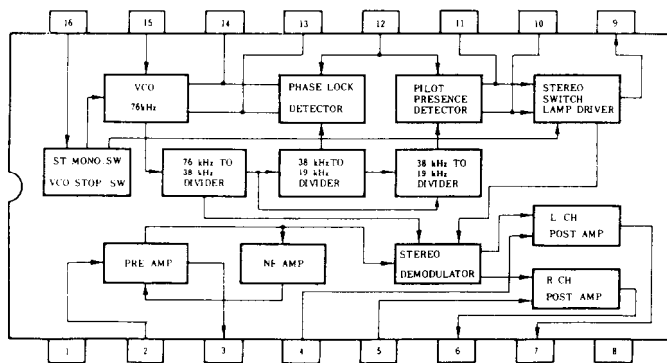

PACKING VIEW

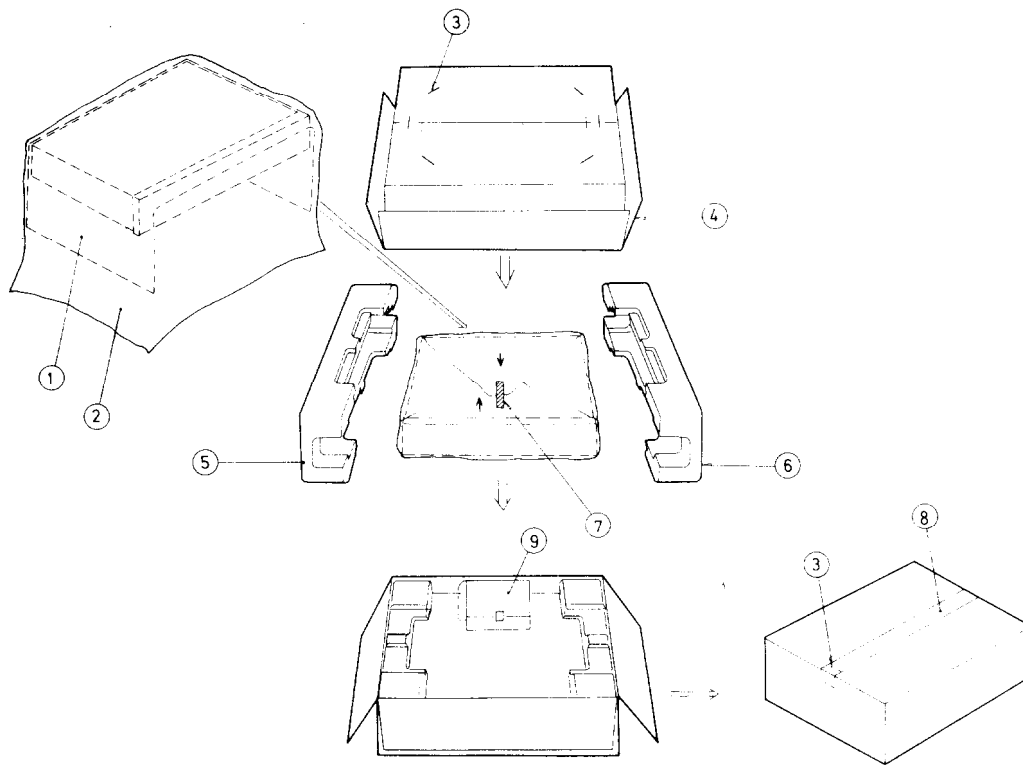

REF. NO.	PARTS NO.	DESCRIPTION
1	29095012-1	500×800mm, Protection sheet
2	29100034	650×850mm, Poly-vinyl bag
3	282301	Sealing hook
4	29050967	Master carton box
	29050968	Master carton box (B)
5	29090817A	Pad R
6	29090816B	Pad L
7	29110032	W=15mm, Adhesive tape
8	260012	50(W)×600mm, Damplon tape
9		Accessory bag complete
	U.S.A. model	
	292064A	FM antenna
	29100006	350×250mm, Poly-vinyl bag
	29340770	Instruction manual
	29365006-5	Warranty card
	29358002A	Service station list
	120V model	
	292064A	FM antenna
	29100006	350×250mm, Poly-vinyl bag
	29340770	Instruction manual
	220V model	
	292064A	FM antenna
	29100006	350×250mm, Poly-vinyl bag
	29340771	Instruction manual
	120/220V model	
	292064A	FM antenna
	29100006	350×250mm, Poly-vinyl bag
	29340771	Instruction manual
	25055040	CV-K-2, Conversion plug

Note: (B): Only black model

ONKYO CORPORATION

International Division: No. 24 Mori Bldg., 23-5, 3-chome, Nishi-Shinbashi, Minato-ku, Tokyo, Japan
 Telex: 2423551 ONKYO J. Phone: 03-432-6981

ONKYO U.S.A. CORPORATION

200 Williams Drive, Ramsey, N.J. 07446 Tel: 201-825-7950

ONKYO DEUTSCHLAND GMBH ELECTRONICS

8034 Munchen-Germering, Industriestrasse 18, West Germany. Telex: 521726 Telefon: (089)-84-3071