

ONKYO® SERVICE MANUAL

QUARTZ SYNTHESIZED

TUNER AMPLIFIER

MODEL TX-30

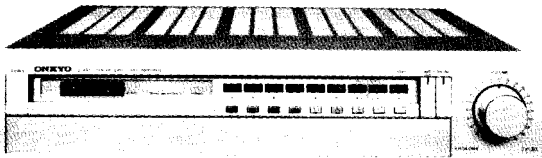

120V model

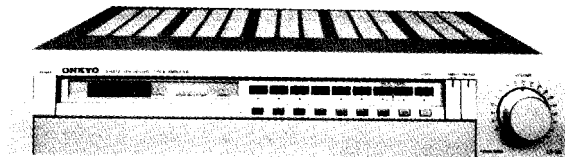

220V model

TABLE OF CONTENTS

Item	Page
Specifications	2
Service procedures	3
Alignment procedures	4
Component location	6
FM/AM tuner pc board parts list (220V model)	7
Lamp pc board view	7
FM/AM tuner pc board view (220V model)	8
FM/AM tuner-schematic diagram (220V model)	9
FM/AM tuner-schematic diagram (120V model)	11
FM/AM tuner pc board view (120V model)	13
Block diagram for IC	14
Equalizer amplifier pc board view	15
Rectifier pc board view	15
Digital circuit pc board view	16
Schematic diagram (220V model)	17
Schematic diagram (120V model)	19
Pre. and power amplifier pc board view	21
Exploded view	23
Packing procedures	24

ONKYO®
AUDIO COMPONENTS

SPECIFICATIONS

AMPLIFIER SECTION

Output Power	
Continuous :	40 watts per channel at 8 ohms, both channels driven, from 20 Hz — 20 kHz, 0.03% THD 45 watts per channel at 8 ohms, both channels driven, 1kHz, 0.03% THD
Dynamic :	130 watts total at 8 ohms 0.03% THD
Total Harmonic Distortion :	0.03% at rated power 0.03% at 1 watt output
IM Distortion :	0.1% at rated power 0.03% at 1 watt output
Damping Factor :	40 at 8 ohms
Frequency Response :	20 Hz — 30,000 Hz (± 1 dB)
RIAA Deviation :	20 Hz — 20,000 Hz (± 0.8 dB)
Sensitivity & Impedance :	Phono : 2.5 mV, 50 kohms Tape Play : 150 mV, 50 kohms Tape Rec : 150 mV, 1 kohms (PH)
Phono Overload :	180 mV RMS at 1 kHz, 0.03% THD
Signal-to-Noise Ratio :	
Phono :	75 dB (IHF A-202, 1 watt output, 5 mV input)
Tape :	80dB (IHF A-202, 1 watt output, 0.5V input)
Tone controls	
Bass :	± 8 dB at 100 Hz
Treble :	± 8 dB at 10 kHz
High Filter :	6 kHz (6 dB/oct)
Loudness (-30dB) :	+6 dB at 70 Hz +5 dB at 10 kHz

TUNER SECTION

120V model	
FM:	
Tuning Range :	87.9 — 108.1 MHz (200 kHz steps)
Usable Sensitivity :	
Mono :	10.8 dBf, 1.9 μ V, IHF
Stereo :	17.2 dBf, 4 μ V
50 dB Quieting Sensitivity :	
Mono :	16.2 dBf, 3.5 μ V
Stereo :	36.2 dBf, 35 μ V
Capture Ratio :	1.5 dB
Image Rejection Ratio :	80 dB
IF Rejection Ratio :	90 dB
Spurious Rejection Ratio :	90 dB
Signal-to-Noise Ratio	
Mono :	70 dB
Stereo :	66 dB
Alternate Channel Att :	60 dB
AM Suppression Ratio :	52 dB
Harmonic Distortion :	
Mono :	0.12%
Stereo :	0.25%
Frequency Response :	30 Hz — 15,000 Hz (± 1.5 dB)
Stereo Separation :	40 dB at 1 kHz 30 dB at 100 Hz — 10,000 Hz
Muting Level :	17.2 dBf, 4 μ V
Stereo Threshold :	17.2 dBf, 4 μ V
AM:	
Tuning Range :	530 — 1620 kHz (10 kHz steps)
Usable Sensitivity :	50 μ V
Image Rejection Ratio :	45 dB
IF Rejection Ratio :	30 dB
Signal-to-Noise Ratio :	42 dB
Harmonic Distortion :	0.8%

TUNER SECTION

220V model	
FM:	
Tuning Range :	87.5 — 108 MHz (50 kHz steps)
Usable Sensitivity :	
Mono :	1.9 μ V (10.8 dBf) IHF, 1.4 μ V (S/N 26 dB, 40 kHz Devi.) DIN; 0.7 μ V (S/N 26 dB, 40 kHz Devi.) DIN, 75 Ω
Stereo :	4 μ V (17.2 dBf) IHF; 40 μ V (17.2 dBf) IHF; 40 μ V (S/N 46 dB, 40 kHz Devi.) DIN
50 dB Quieting Sensitivity :	
Mono :	3.5 μ V (16.2 dBf)
Stereo :	35 μ V (36.2 dBf)
Capture Ratio :	1.5 dB
Image Rejection Ratio :	80 dB
IF Rejection Ratio :	90 dB
Spurious Rejection Ratio :	90 dB
Signal-to-Noise Ratio :	
Mono :	70 dB
Stereo :	66 dB
Alternate Channel Att :	75 dB (IHF)
Selectivity :	55 dB (DIN) (± 300 kHz, 40 kHz Devi.)
AM Suppression Ratio :	52 dB
Harmonic Distortion :	
Mono :	0.15%
Stereo :	0.3%
Frequency Response :	30 Hz — 15,000 Hz (± 1.5 dB)
Stereo Separation :	40 dB at 1 kHz 30 dB at 100 Hz — 10,000 Hz
Muting Level :	4 μ V 17.2 dBf
Stereo Threshold :	4 μ V 17.2 dBf
AM:	
Tuning Range :	513 — 1620 kHz (9 kHz steps)
Usable Sensitivity :	50 μ V
Image Rejection Ratio :	45 dB
IF Rejection Ratio :	30 dB
Signal-to-Noise Ratio :	42 dB
Harmonic Distortion :	0.8%
GENERAL	
Power Supply :	AC 220 volts, 50/60 Hz AC 120 volts, 60 Hz
Australia or United Kingdom :	AC 240 V, 50 Hz
Outputs :	Speaker A & B, Phones, Tape Rec 1 & 2, FM and AM Antennas
Antennas :	
FM :	300 ohms balanced and 75 ohms unbalanced
AM :	built-in ferrite core antenna and external terminal
Semiconductors :	4 FETs, 45 transistors, 15 ICs, 64 diodes (G model) 4 FETs, 44 transistors, 15 ICs, 66 diodes, 1 fluorescent digital display tube (D model)
Dimensions (W x H x D) :	418 x 83 x 380 mm 16-9/16" x 3-1/4" x 15"
Weight :	7.8 kg, 17.2 lbs
Specifications and features are subject to change without notice.	

SERVICE PROCEDURES

1. Disassembly

1. Top cover

Remove the six screws holding the top cover and side bracket.

Remove the screw holding the top cover and back panel.

2. Front panel

Remove the five screws holding the front panel and front bracket.

3. Digital circuit pc board

Cut the three binders binding the lead wires.

4. L.E.Ds for power, tape and phono indicator

Remove the top cover and the front panel.

Disconnect the L.E.D by extending the nails of guide from both side.

5. L.E.Ds for station indicator

Remove the top cover and front panel.

Remove the three screws (1) holding the dial plate and front bracket.

Remove the four screws (2) as shown in the fig. 1.

3. Nylon clothing should not be worn while handling MOS circuits.
4. When lead straightening or hand soldering is necessary, provide ground straps for the apparatus used.
5. Double check test equipment setup for proper polarity of voltage before conducting parametric or functional testing.
6. All unused device inputs should be connected to VDD or VSS.

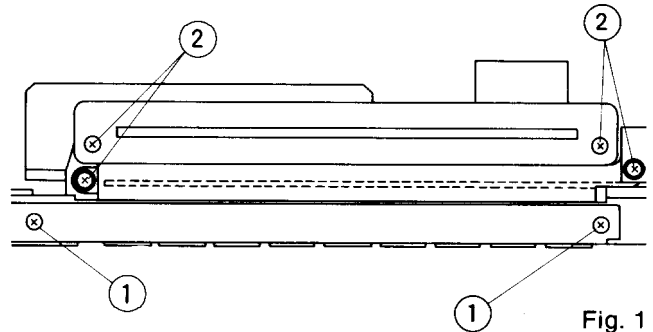

Fig. 1

2. Replacing the fuses

Remove the top cover. The speaker protection fuses are located on the pre., and power amplifier pc board. The AC fuses are located on the rectifier pc board as shown in the fig. 2.

Caution: For continued protection against fire hazard, replace only with same type and same rating fuse.

	Circuit No.	Parts No.	Description	Remarks
Speaker fuse	F501, F601	252014	4A-T	
	F901	252049	4A (ST-6)	120V model
AC fuse	F901	252075	2.5A-SE-EAK	220V model
	F902, F903	252078	5A-SE-EAK	220V model

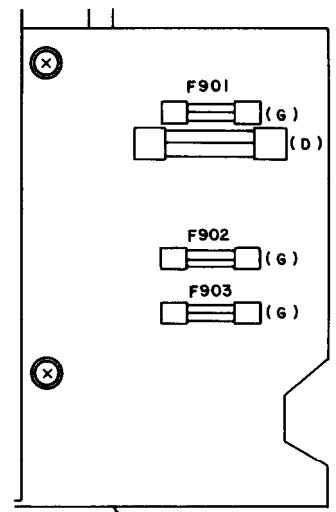

Fig. 2

3. Replacing the memory IC (circuit no. Q706)

Replace the memory IC and push the power switch to "ON" position. Count the numbers of light digit of fluorescent digital display tube. When the fluorescent digital display tube lights up more than two digits, connect the short clip (lead wire) between terminals 12 and E on the digital pc board for approx. 1 sec. Then confirm that the indicator of fluorescent tube becomes 79.9 MHz (120V model) or 79.5 MHz (220V model) and the position of station indicator becomes FM 7.

When lights up less than one digit, push the power switch to off position. Connect the shorted clip between terminal no. 7 and 8 of Q704, push the power switch to "ON" position. After confirm that the indicator of fluorescent tube becomes three zeros (000) for 120V model or four zeros (0000) for 220V model, connect the shorted clip between terminals 12 and E on the digital pc board for approx. 1 sec.

4. Precaution

1. All MOS devices should be stored or transported in materials that are somewhat conductive. MOS devices must not be inserted into conventional plastic "snow" or plastic trays.
2. All MOS devices should be placed on a grounded bench surface and operators should ground themselves prior to handling devices, since a worker can be statically charged with respect to the bench surface.

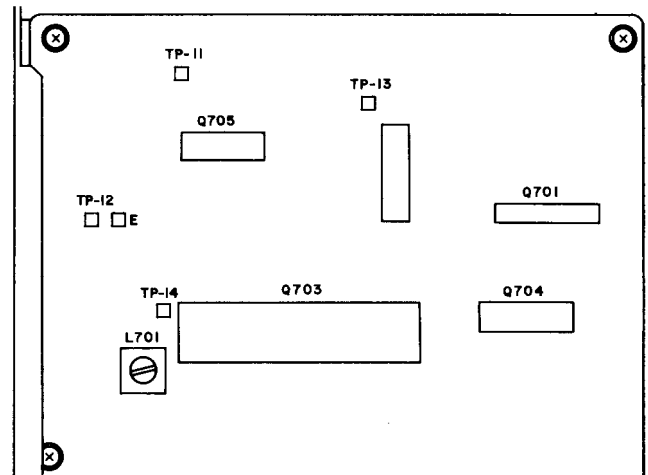

Fig. 3

ALIGNMENT PROCEDURES

INSTRUMENTS REQUIRED

1. Stereo Modulator
2. FM Signal Generator with Frequency Counter
3. Frequency Counter
4. Digital DC Voltmeter
5. DC Voltmeter
6. Distortion Analyzer
7. AC Volt meter
8. Oscilloscope

1. Front end adjustment

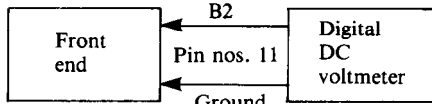

Step	Set to dial	Adjust	Output indicator	Adjust for
FM adjustment				
1	88.1 MHz	L008 (LO)	Digital DC voltmeter	3.03V
2	107.9MHz	TC004 (TCO)		20.8V
3	Repeat steps 1 and 2 as necessary			
AM adjustment (120V model)				
1	600 kHz	L151	Digital DC voltmeter	2.5V
2	1400 kHz	TC152		15.5V
3	Repeat steps 1 and 2 as necessary			
AM adjustment (220V model)				
1	603 kHz	L151	Digital DC voltmeter	2.5V
2	1404 kHz	TC152		15.5V
3	Repeat steps 1 and 2 as necessary			

Remark : Usually not necessary to adjust.

2. AM IF adjustment

1. Set the dial to quiet point.

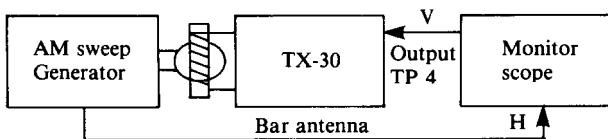

Set signal	Adjust	Adjust for
450 kHz	L152	The output of monitor scope becomes maximum symmetrical response

Remark : Usually not necessary to adjust.

GENERAL ALIGNMENT CONDITION

1. Standard modulation is 1 kHz 100% (FM MONO), pilot 9% sub and main 91%
2. Standard knob position
 MODE.....STEREO
 MUTING.....OFF

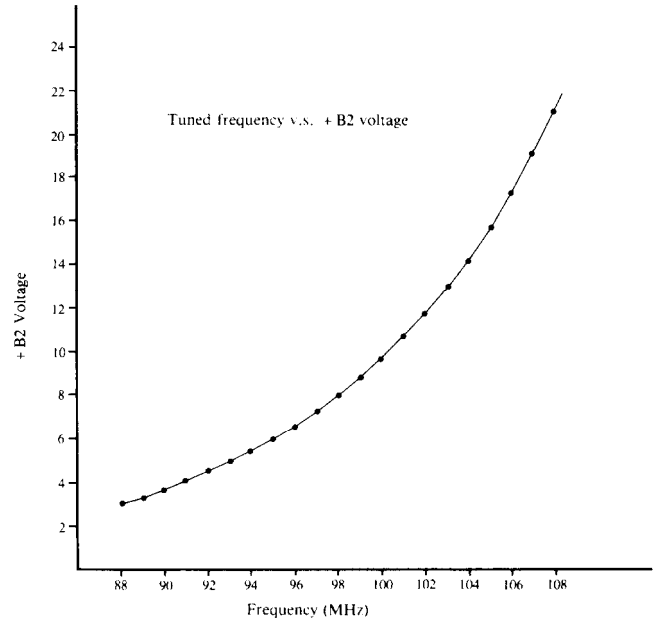

3. AM RF adjustment

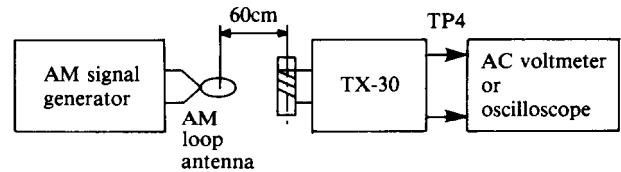

	AM Signal generator	Dial to set	Adjust	Adjust for
1	600kHz (603kHz) 400Hz, 30% mod.	600kHz (603kHz)	AM bar antenna	Maximum
2	1400kHz (1404kHz) 400Hz, 30% mod.	1400kHz (1404kHz)	TC151	Maximum
3.	Repeat steps 1 and 2 as necessary			

NOTE : () : 220 V model

4. Adjustment of oscillator coil for Q703

1. Connect the frequency counter to the terminals TP14 and E on the digital circuit pc board.
2. Adjust the oscillator coil L701 so that the indicator of counter becomes 400 kHz.

NOTE : Usually not necessary to adjust.

5. FM adjustment

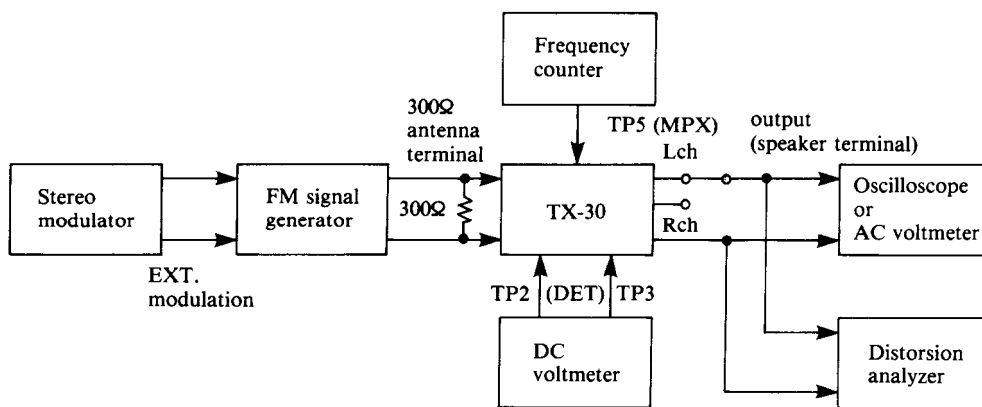

Item	FM signal generator	Stereo modulator	Dial to set	Adjust	Output indicator	Adjust for	Remarks
FM IF	1	_____	No input signal	L101	DC voltmeter	0V	Repeat steps 1 and 2 as necessary
	2	98.1MHz, 65dBf, 1kHz, 75kHz devi.	98.1MHz	L102	Distorsion analyzer	Minimum	
V.C.O	98.1MHz 65dBf	_____	98.1MHz	R213	Frequency counter	76kHz	Turn off the modulation
Stereo Separation	98.1MHz 65dBf Ext. modulation	Rch	98.1MHz	R201	AC voltmeter (Lch)	Minimum	Maximum and same separation
		Lch			AC voltmeter (Rch)	Minimum	
Muting level	98.1MHz, 17dBf 1kHz, 75kHz devi.	_____	98.1MHz	R116	Oscilloscope	Signal	Set the muting switch to on position
	98.1MHz, 16dBf 1kHz, 75kHz devi.	_____				No signal	

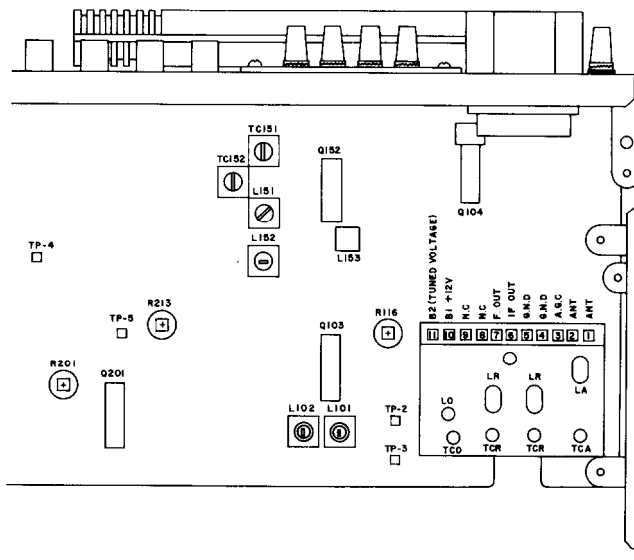

Adjustment points

COMPONENT LOCATION

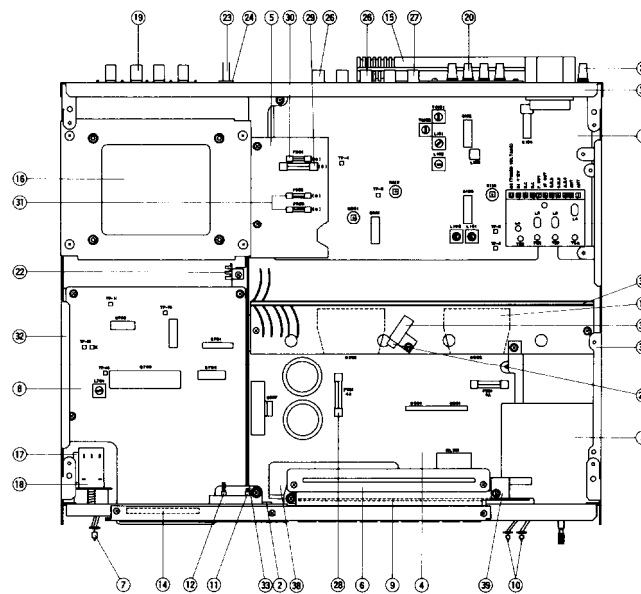

120V model

REF. NO.	CIRCUIT NO.	PARTS NO.	DESCRIPTION
1	U1	13469551	NARF-951, FM/AM tuner pc board ass'y
2	U2	13469552	NADIS-952, L.E.D. pc board ass'y
3	U3	13469553	NAEQ-953, Equalizer amplifier pc board ass'y
4	U4	13469554	NAAF-954, Pre. and power amplifier pc board ass'y
5	U5	13469555	NARC-955, Rectifier pc board ass'y
6	U6	13469556	NAPL-956, Lamp circuit pc board ass'y
7	U7	13469557	NADIS-957, L.E.D pc board ass'y
8	U8	13469561	NADG-961, Digital circuit pc board ass'y
9	U9	13469562	NASW-962, Switch circuit pc board ass'y
10	U10	13469563	NADIS-963, L.E.D. pc board ass'y
11	PL804	210105	PL6.3V0.1AW-6, Tuned lamp
12	PL805	210106	PL14V0.06AW-6, Signal lamp
13	Q502, Q602	222025	STK-1050, Power amplifier IC
14	Q720	212008	7-ST-01, Fluorescent indicator tube
15	T101	232083	NMA-3033, AM bar antenna
16	T901	230441	NPT-718D, Power transformer
17	C901	3500060	0.01μF, 125V, CS capacitor
18	S901	25035061A	NPS-121-L26P, Power switch
19	P501, P601	25060038	NTM-4PRMN09, Speaker terminal
20	P001	25060035	NTM-4PRMC06, Antenna terminal
21		25060044	Ground terminal
		87313006	M3-8, Toothed washer
22		250130	T-4461, Ground terminal
23		253099A	AS-UC-3, Power supply cable
24		270025	SR-3P-4, Strainrelief
25		25065127	1P-105A-100, Thermal switch
26		25045025	NPJ-4PRBL03, Tape input/output terminal
27		25045026	NPJ-2PRBL04, Phono input terminal
28		252014	4A-T, Speaker protection fuse
29	F901	252049	4A(ST-6), AC fuse
32		27115074	Side bracket
33		27130226	Bracket, pc board
34		27115075	Side bracket
35		27120263A	Back panel
36		27160078Z	Radiator
37		270281	Holding plate, thermal switch
38		27150121	Shielded plate (A)
39		27150122A	Shielded plate (B)
		25050032	SI-6444-01, AC outlet

220V model

REF. NO.	CIRCUIT NO.	PARTS NO.	DESCRIPTION
1	U1	13472551A	NARF-951a, FM/AM tuner pc board ass'y
2	U2	13469552	NADIS-952, L.E.D. pc board ass'y
3	U3	13469553	NAEQ-953, Equalizer amplifier pc board ass'y
4	U4	13469554	NAAF-954, Pre. and power amplifier pc board ass'y
5	U5	13472555A	NARC-955a, Rectifier pc board ass'y
6	U6	13469556	NAPL-956, Lamp circuit pc board ass'y
7	U7	13469557	NADIS-957, L.E.D pc board ass'y
8	U8	13472561A	NADG-961a, Digital circuit pc board ass'y
9	U9	13472562A	NASW-962a, Switch circuit pc board ass'y
10	U10	13469563	NADIS-963, L.E.D. pc board ass'y
11	PL804	210105	PL6.3V0.1AW-6, Tuned lamp
12	PL805	210106	PL14V0.06AW-6, Signal lamp
13	Q502, Q602	222025	STK-1050, Power amplifier IC
14	Q720	212008	7-ST-01, Fluorescent indicator tube
15	T101	232083	NMA-3033, AM bar antenna
16	T901	230442	NPT-718G, Power transformer
17	C901	3500058	PME265MB510, IS capacitor
18	S901	25035051	NPS-121-L16P, Power switch
19	P501, P601	25060038	NTM-4PRMN09, Speaker terminal
20	P001	25060035	NTM-4PRMC06, Antenna terminal
21		25060044	Ground terminal
		87313006	M3-8, Toothed washer
22		250130	T-4461, Ground terminal
23		253083	AS-CEE, Power supply cable
24		270280	SR-4K-4, Strainrelief
25		25065127	1P-105A-100, Thermal switch
26		25045025	NPJ-4PRBL03, Tape input/output terminal
27		25045026	NPJ-2PRBL04, Phono input terminal
28		252014	4A-T, Speaker protection fuse
30		252075	2.5A-SE-EAK, AC fuse
31		252078	5A-SE-EAK, AC fuse
32		27115074	Side bracket
33		27130226	Bracket, pc board
34		27115075	Side bracket
35		27120264	Back panel
36		27160078Z	Radiator
37		270281	Holding plate, thermal switch
38		27150121	Shielded plate (A)
39		27150122A	Shielded plate (B)

FM/AM TUNER PC BOARD (NARF-951a)-PARTS LIST
220V model

CIRCUIT NO. PARTS NO. DESCRIPTION

	ICs	
Q103	222608	μPC1167C2
Q104	222541	LB1426
Q152	222497	LA1240
Q201	222453	HA1196
Q204	222840661	4066
Q951	222780122	78M12

	Transistors	
Q101, Q102	2211722	2SC1923 (R)
Q106, Q110	2211254,	2SC1815 (Y),
Q153-Q155	2211255 or	2SC1815 (GR) or
Q203, Q205	2210746	2SC945A(P)
Q109	2211164	2SC2120 (Y)
Q151, Q202	2211293	2SK68(M)
Q206, Q801	2211254,	2SC1815 (Y),
Q802-Q804	2211255 or	2SC1815(GR) or
Q808, Q810	2210746	2SC945A(P)
Q807	2211255	2SC1815(GR)

	Diodes	
D101, D102	223105 or	1S1555 or
D106, D153	223133	DS442X
D154	4000068	VD1212
D151, D152	223136	KV1226
D201-D204	223105 or	1S1555 or
D801-D803	223133	DS442X
D807, D810	223105 or	1S1555 or
D812, D813	223133	DS442X

	Transformers & coils	
L101	233229	NFIF-6022P
L102	233230	NFIF-6022S
L151	232084	NMO-2018
L152	232077	NMIF-6009
L153	232041	NIT-0509
L201, L202	233181	NMC-5018
L801	233031	NMC-9-1

	Ceramic filters	
X101-X103	3010043 or	SFE-10.7MM or
	3010006	SFE-10.7MA8-A
(When replacing, use the same rating and same color dot.)		
X151	3010049	CFM2-450BL

CIRCUIT NO.	PARTS NO.	DESCRIPTION
	Capacitors	
TC151, TC152	3060007	NTC-15P06, Trimmer
C103	352741009	10μF, 50V, Elect.
C105	352780339	3.3μF, 50V, Elect.
C109	352780229	2.2μF, 50V, Elect.
C110	352784799	0.47μF, 50V, Elect.
C117	352780229	2.2μF, 50V, Elect.
C118-C119	352741009	10μF, 16V, Elect.
C123	352780109	1μF, 50V, Elect.
C155	372525114	510pF±5%, 50V, ST
C159	352741009	10μF, 16V, Elect.
C165	352721019	100μF, 6.3V, Elect.
C168	352750479	4.7μF, 25V, Elect.
C169	352780339	3.3μF, 50V, Elect.
C172	352744709	47μF, 16V, Elect.
C174	352780109	1μF, 50V, Elect.
C175	352741009	10μF, 16V, Elect.
C201	352750479	4.7μF, 25V, Elect.
C205, C206	352741009	10μF, 16V Elect.
C207	352742219	220μF, 16V Elect
C209	372523614	360pF±5%, 50V, ST
C210	352780109	1μF, 50V, Elect,
C211	352780339	3.3μF, 50V, Elect
C212	352784799	0.47μF, 50V, Elect.
C214, C215	352780339	3.3μF, 50V, Elect.
C216, C217	352741009	10μF, 16V, Elect.
C218	352744709	47μF, 16V, Elect.
C803	352742209	22μF, 16V, Elect.
C807	352780229	2.2μF, 50V, Elect.
C808, C809	352784799	0.47μF, 50V, Elect.
C951	352780339	3.3μF, 50V, Elect.
C954	352754719	470μF, 25V, Elect.
	Resistors	
R116	5225034	N10HR47KBD, Semi-fixed
R139	441627504	75Ω, 1W, Metal oxide film
R201	5225037	N10HR220KBD, Semi-fixed
R213	5225015	N10HR10KBD, Semi-fixed
R228	441522204	22Ω, 1/2W, Metal oxide film
R951	451730824	8.2Ω, 2W, Metal
	Front End	
	240043	FD236U14

LAMP PC BOARD VIEW FROM BOTTOM SIDE

Before change

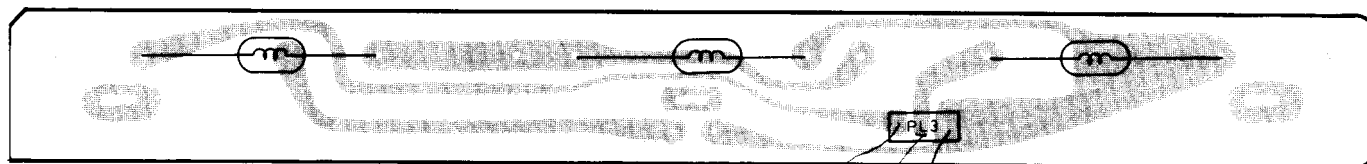

After change

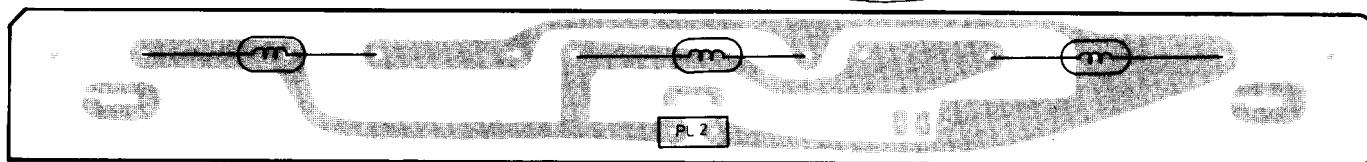

PARTS NO.	DESCRIPTION	REMARKS
210038	150mA, 12V, Lamp	Before change
210115	80mA, 24V, Lamp	After change

FM/AM TUNER PC BOARD (NARF-951)-PARTS LIST 120V model

CIRCUIT NO. PARTS NO. DESCRIPTION

CIRCUIT NO.	PARTS NO.	DESCRIPTION
ICs		
Q103	222608	μ PC1167C2
Q104	222541	LB1426
Q152	222497	LA1240
Q201	222453	HA1196
Q204	222840661	4066
Q951	222780122	78M12
Transistors		
Q102	2211722	2SC1923 (R)
Q106, Q110	2211254,	2SC1815 (Y),
Q153-Q155	2211255 or	2SC1815 (GR) or
Q203, Q205	2210746	2SC945A(P)
Q109	2211164	2SC2120 (Y)
Q151, Q202	2211293	2SK68(M)
Q206, Q801	2211254,	2SC1815 (Y),
Q802-Q804	2211255 or	2SC1815(GR) or
Q808, Q810	2210746	2SC945A(P)
Q807	2211255	2SC1815(GR)
Diodes		
D101, D102	223105 or	1S1555 or
D106, D153	223133	DS442X
D154	4000068	VD1212
D151, D152	223136	KV1226
D201-D204	223105 or	1S1555 or
D801-D803	223133	DS442X
D807, D810	223105 or	1S1555 or
D812, D813	223133	DS442X

Transformers & coils

L101	233229	NFIF-6022P
L102	233230	NFIF-6022S
L151	232084	NMO-2018
L152	232077	NMIF-6009
L153	232041	NIT-0509
L201, L202	233181	NMC-5018
L801	233031	NMC-91

Ceramic filters

X102-X103	3010006 or	SFE-10.7MA8-A or
	3010043	SFE 10.7MM
(When replacing, use the same rating and same color dot.)		
X151	3010049	CFM2-450BL

Capacitors

TC151, TC152	3060007	NTC-15P06, Trimmer
C103	352741009	10 μ F, 16V, Elect.
C105	352780339	3.3 μ F, 50V, Elect.
C109	352780229	2.2 μ F, 50V, Elect.
C110	352784799	0.47 μ F, 50V, Elect.
C117	352780229	2.2 μ F, 50V, Elect.
C118-C119	352741009	10 μ F, 16V, Elect.
C123	352780109	1 μ F, 50V, Elect.
C155	372525114	510pF \pm 5%, 50V, ST
C159	352741009	10 μ F, 16V, Elect.
C165	352721019	100 μ F, 6.3V, Elect.
C168	352750479	4.7 μ F, 25V, Elect.
C169	352780339	3.3 μ F, 50V, Elect.

BLOCK DIAGRAM

μ PC1167 (FM IF system)

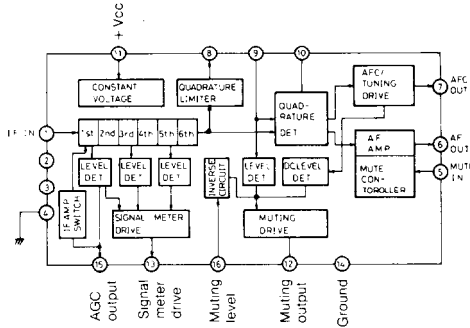

LB-1426 (Single indicator drive)

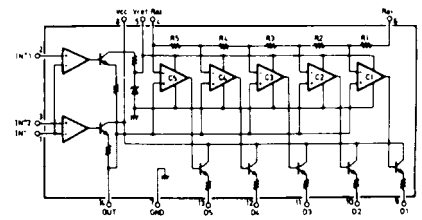

LA-1240 (AM radio system)

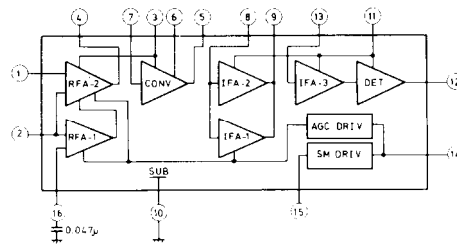

HA-1196 (MPX decoder)

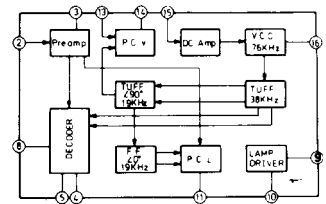

C172	352744709	47 μ F, 16V, Elect.
C174	352780109	1 μ F, 50V, Elect.
C175	352741009	10 μ F, 16V, Elect.
C201	352750479	4.7 μ F, 25V, Elect.
C205, C206	352741009	10 μ F, 16V Elect.
C207	352742219	220 μ F, 16V Elect.
C209	372523614	360pF \pm 5%, 50V, ST
C210	352780109	1 μ F, 50V, Elect.
C211	352780339	3.3 μ F, 50V, Elect.
C212	352784799	0.47 μ F, 50V, Elect.
C214, C215	352780339	3.3 μ F, 50V, Elect.
C216, C217	352741009	10 μ F, 16V, Elect.
C218	352744709	47 μ F, 16V, Elect.
C803	352742209	22 μ F, 16V, Elect.
C807	352780229	2.2 μ F, 50V, Elect.
C808, C809	352784799	0.47 μ F, 50V, Elect.
C951	352780339	3.3 μ F, 50V, Elect.
C954	352754719	470 μ F, 25V, Elect.

Resistors

R116	5225034	N10HR47KBD, Semi-fixed
R139	441627504	75 Ω , 1W, Metal oxide film
R201	5225037	N10HR220KBD, Semi-fixed
R213	5225015	N10HR10KBD, Semi-fixed
R228	441522204	22 Ω , 1/2W, Metal oxide film
R951	451730824	8.2 Ω , 2W, Metal

Front End

TU001	240043	FD236U14
-------	--------	----------

4066 (Quad bilateral switch)

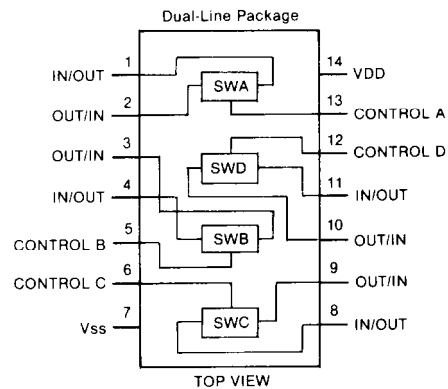

**EQUALIZER AMPLIFIER PC BOARD (NAEQ-953)-
PARTS LIST**

CIRCUIT NO.	PARTS NO.	DESCRIPTION
	IC	
Q301, Q401	222534	NJM-4559DX
	Capacitors	
Q302, C402	392880227	2.2 μ F, 50V, LL
C305, C405	352721019	100 μ F, 6.3V, Elect.
C309, C409	392880227	2.2 μ F, 50V, LL
C310, C311	352780339	3.3 μ F, 50V, Elect.
	Resistor	
R358, R359	5148052	N16RGM41C250KBTP35, Volume control variable

**RECTIFIER PC BOARD (NARC-955)-PARTS LIST
120V model**

CIRCUIT NO.	PARTS NO.	DESCRIPTION
	Diodes	
D901-D904	223863	GP-30DL
	Fuseholder	
	250113	SN5051
	Fuse	
F901	252049	4A (ST-6)

**RECTIFIER PC BOARD (NARC-955a)-PARTS LIST
220V model**

CIRCUIT NO.	PARTS NO.	DESCRIPTION
	Diodes	
D901-D904	223863	GP-30DL
	Fuseholder	
	25050065	YSH403T
	Fuses	
F901	252075	2.5A-SE-EAK
F902, F903	252078	5A-SE-EAK

DIGITAL CIRCUIT PC BOARD (NADG-961)-PARTS LIST

CIRCUIT NO.	PARTS NO.	DESCRIPTION
	ICs	
Q701	222609	TD6102P
Q702	222610 or 222615	TC9125BP or TC9125P
Q703	222611	μ PD553C-068
Q704	222740420	7442
Q705	222612 or 222613	M5G1400P or ER1400
	Transistors	
Q706, Q707	2211255	2SC1815(GR)
Q708	2211254	2SC1815 (Y)
Q709-Q714	2211454	2SA1015(Y)
Q715	2211455	2SA1015(GR)
Q716	2211254	2SC1815(GR)
Q717	2211454	2SA1015(Y)
Q718	2211254	2SC1815(Y)
Q721	2211255	2SC1815(GR)
	Diodes	
D703-D706	223105 or 223133	1S1555 or DS442X(Only 120V model)
D708	223133	DS442X(Only 120V model)
D702, D704	223105 or 223133	1S1555 or DS442X (Only 220V model)
D705, D707	223105 or 223133	1S1555 or DS442X
D710—D715	223105 or 223133	1S1555 or DS442X
D721	223103	1N60
D716, D717	223132 or 223103	1K60 or 1N60
D718, D719	224128	RD3.9EB
D720	224102 or 224047	GZA7.5U or 05Z7.5U
	Coils	
L701	232088	NMO-2019
L702	233188	NCH-1033
	Capacitors	
C703	395164797	0.47 μ F, 35V, Ta
C711	352741009	10 μ F, 16V, Elect.
C720	352751009	10 μ F, 25V, Elect.
C721	352744709	47 μ F, 16V, Elect.
C722	352742209	22 μ F, 16V, Elect.
C723	352750339	3.3 μ F, 25V, Elect.
C725	352781599	0.15 μ F, 50V, Elect.
	X'tal	
X701	3010050	XTL-9.0M

DIGITAL CIRCUIT PC BOARD (NADG-961)- PARTS LIST

CIRCUIT NO.	PARTS NO.	DESCRIPTION
	Resistor	
R734	441723014	300Ω, 2W, Metal oxide film
	Lead wires	
	79134	JL6-50-5-5-P2.5
	79133	JL3-50-5-5-P2.5

SWITCH CIRCUIT PC BOARD (NASW-962)- PARTS LIST

CIRCUIT NO.	PARTS NO.	DESCRIPTION
	L.E.Ds	
D771, D772	225057	SR538D
D773-D779	225062	SG238D
D782	225018	GL-2PR1
	Diodes	
D783-D793	223133 or 223105	DS442X or 1S1555
	Push switches	
S771-S777	25035156	NPS-111-S120
S778, S779	25035089	NPS-111-S54
S780, S781	25035156	NPS-111-S120
S782-S784	25035089	NPS-111-S54

L.E.D. PC BOARDS (NADIS-952/957/963)-PARTS LIST

CIRCUIT NO.	PARTS NO.	DESCRIPTION
D203	225046	SLP-151B
D910	225047	SLP-251B
	225047	SLP-251B

SCHEMATIC DIAGRAM

220V model

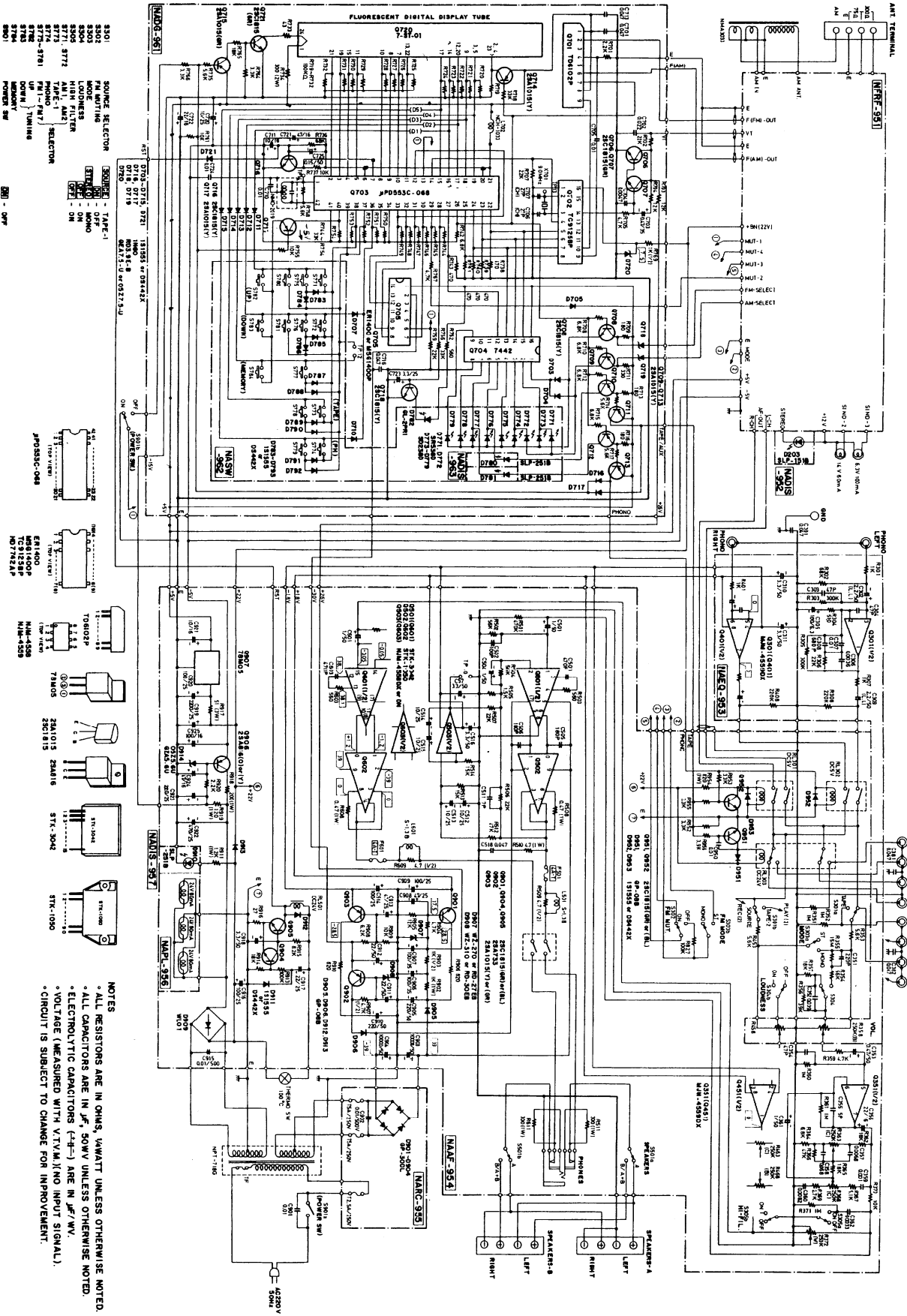

3301 SOURCE SELECTOR
3302 M-WARNING
3303 3304 ADDRESS
3305 HIGH FILTER
3306 TUNE-LOCK
3307 TUNE-LOCK
3308 TUNE-LOCK
3309 TUNE-LOCK
3310 TUNE-LOCK

3301 SOURCE SELECTOR
3302 M-WARNING
3303 3304 ADDRESS
3305 HIGH FILTER
3306 TUNE-LOCK
3307 TUNE-LOCK
3308 TUNE-LOCK
3309 TUNE-LOCK
3310 TUNE-LOCK

3301 SOURCE SELECTOR
3302 M-WARNING
3303 3304 ADDRESS
3305 HIGH FILTER
3306 TUNE-LOCK
3307 TUNE-LOCK
3308 TUNE-LOCK
3309 TUNE-LOCK
3310 TUNE-LOCK

3301 SOURCE SELECTOR
3302 M-WARNING
3303 3304 ADDRESS
3305 HIGH FILTER
3306 TUNE-LOCK
3307 TUNE-LOCK
3308 TUNE-LOCK
3309 TUNE-LOCK
3310 TUNE-LOCK

3301 SOURCE SELECTOR
3302 M-WARNING
3303 3304 ADDRESS
3305 HIGH FILTER
3306 TUNE-LOCK
3307 TUNE-LOCK
3308 TUNE-LOCK
3309 TUNE-LOCK
3310 TUNE-LOCK

3301 SOURCE SELECTOR
3302 M-WARNING
3303 3304 ADDRESS
3305 HIGH FILTER
3306 TUNE-LOCK
3307 TUNE-LOCK
3308 TUNE-LOCK
3309 TUNE-LOCK
3310 TUNE-LOCK

3301 SOURCE SELECTOR
3302 M-WARNING
3303 3304 ADDRESS
3305 HIGH FILTER
3306 TUNE-LOCK
3307 TUNE-LOCK
3308 TUNE-LOCK
3309 TUNE-LOCK
3310 TUNE-LOCK

3301 SOURCE SELECTOR
3302 M-WARNING
3303 3304 ADDRESS
3305 HIGH FILTER
3306 TUNE-LOCK
3307 TUNE-LOCK
3308 TUNE-LOCK
3309 TUNE-LOCK
3310 TUNE-LOCK

3301 SOURCE SELECTOR
3302 M-WARNING
3303 3304 ADDRESS
3305 HIGH FILTER
3306 TUNE-LOCK
3307 TUNE-LOCK
3308 TUNE-LOCK
3309 TUNE-LOCK
3310 TUNE-LOCK

NOTES
 * ALL RESISTORS ARE IN OHMS, UNLESS OTHERWISE NOTED.
 * ALL CAPACITORS ARE IN μF , 50WV UNLESS OTHERWISE NOTED.
 * ELECTROLYTIC CAPACITORS (—E—) ARE IN μF /WV.
 * VOLTAGE (MEASURED WITH V.T.V.M.)/NO INPUT SIGNAL.
 * CIRCUIT IS SUBJECT TO CHANGE FOR IMPROVEMENT.

FM/AM TUNER-SCHEMATIC DIAGRAM

220V model

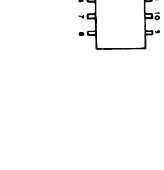
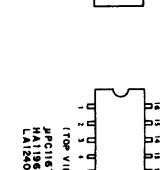
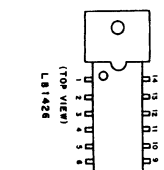
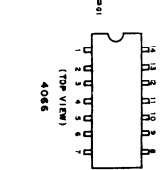
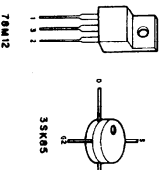
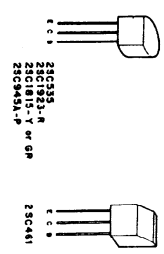
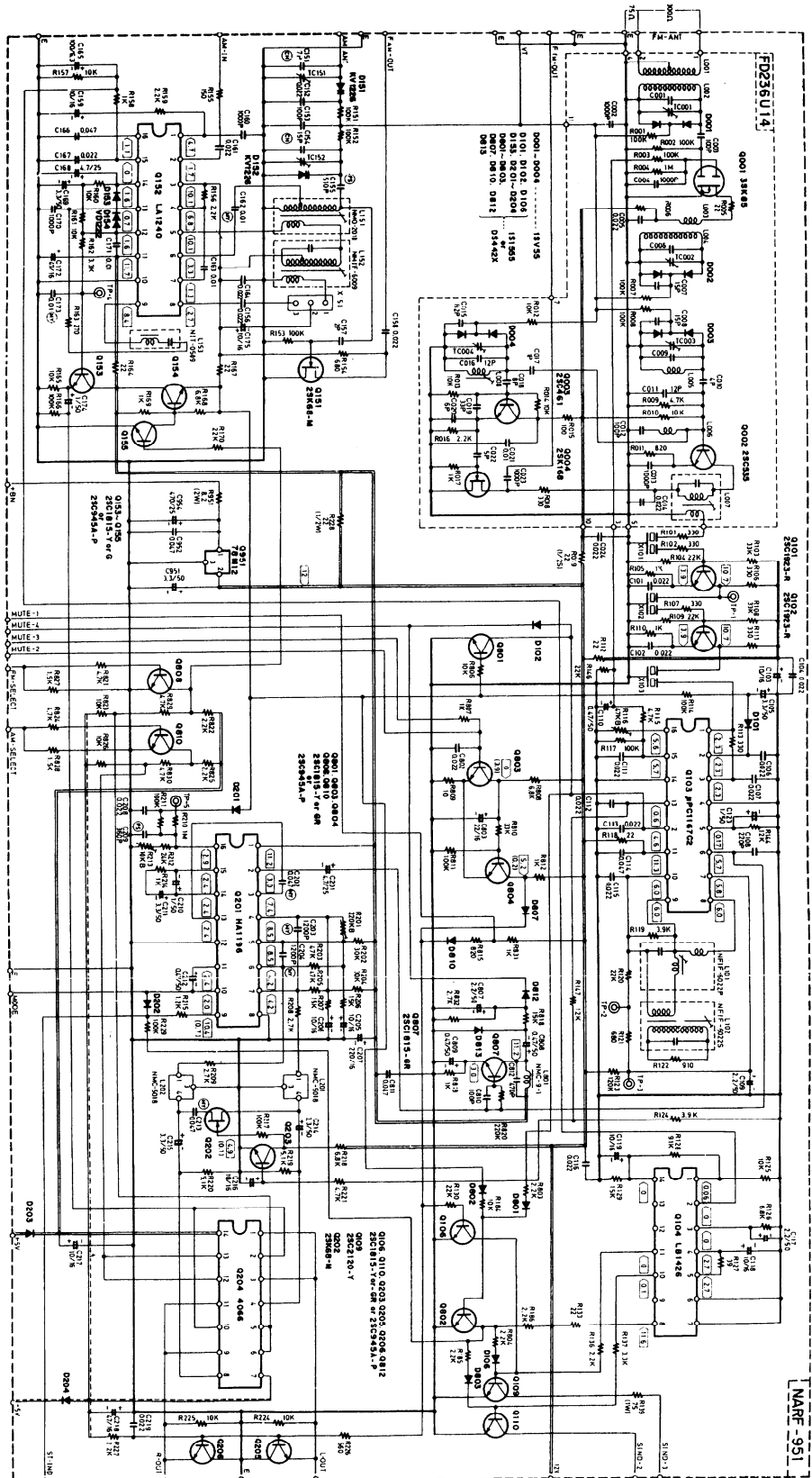

- NOTES
- ALL RESISTORS ARE IN OHMS, $\frac{1}{2}$ WATT UNLESS OTHERWISE NOTED.
 - ALL CAPACITORS ARE IN μF , 50WV UNLESS OTHERWISE NOTED.
 - ELECTROLYTIC CAPACITORS (—E—) ARE IN μF /WV.
 - VOLTAGE (MEASURE WITH V.T.Y.M.) () V DC VOLTAGE (FM STEREO).

SCHEMATIC DIAGRAM

120V model

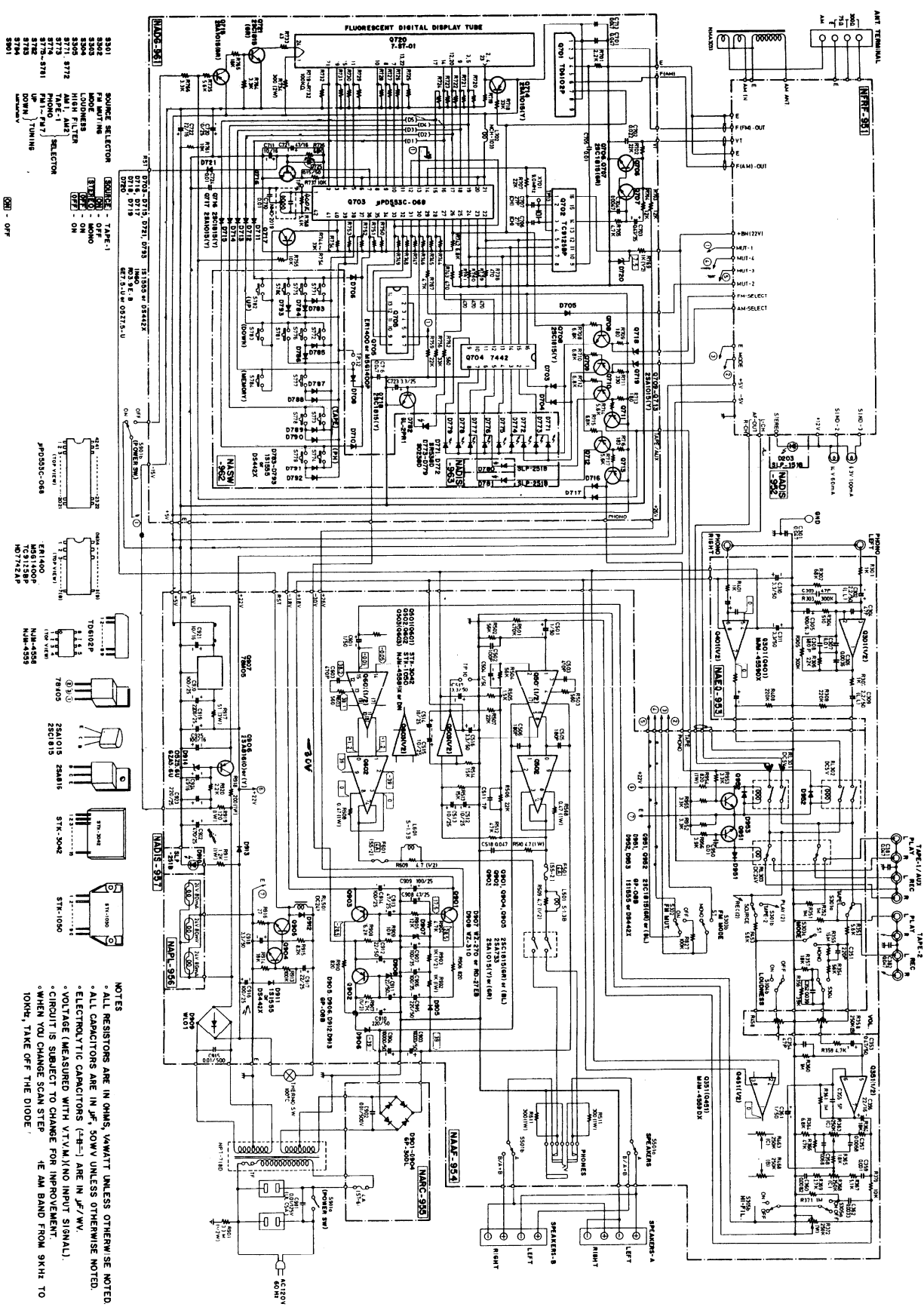

- SOURCE SELECTION
- 8301 FM MATING
 - 8302 MONO
 - 8303 AM
 - 8304 HIGH FILTER
 - 8305 AM1, AM2
 - 8306 PHONO
 - 8307 FM1, FM2
 - 8308 DOWN
 - 8309 TUNING
 - 8310

- ON - OFF
- 8311
 - 8312
 - 8313
 - 8314
 - 8315
 - 8316
 - 8317
 - 8318
 - 8319
 - 8320
 - 8321
 - 8322
 - 8323
 - 8324
 - 8325
 - 8326
 - 8327
 - 8328
 - 8329
 - 8330
 - 8331
 - 8332
 - 8333
 - 8334
 - 8335
 - 8336
 - 8337
 - 8338
 - 8339
 - 8340
 - 8341
 - 8342
 - 8343
 - 8344
 - 8345
 - 8346
 - 8347
 - 8348
 - 8349
 - 8350
 - 8351
 - 8352
 - 8353
 - 8354
 - 8355
 - 8356
 - 8357
 - 8358
 - 8359
 - 8360
 - 8361
 - 8362
 - 8363
 - 8364
 - 8365
 - 8366
 - 8367
 - 8368
 - 8369
 - 8370
 - 8371
 - 8372
 - 8373
 - 8374
 - 8375
 - 8376
 - 8377
 - 8378
 - 8379
 - 8380
 - 8381
 - 8382
 - 8383
 - 8384
 - 8385
 - 8386
 - 8387
 - 8388
 - 8389
 - 8390
 - 8391
 - 8392
 - 8393
 - 8394
 - 8395
 - 8396
 - 8397
 - 8398
 - 8399
 - 8400
 - 8401
 - 8402
 - 8403
 - 8404
 - 8405
 - 8406
 - 8407
 - 8408
 - 8409
 - 8410
 - 8411
 - 8412
 - 8413
 - 8414
 - 8415
 - 8416
 - 8417
 - 8418
 - 8419
 - 8420
 - 8421
 - 8422
 - 8423
 - 8424
 - 8425
 - 8426
 - 8427
 - 8428
 - 8429
 - 8430
 - 8431
 - 8432
 - 8433
 - 8434
 - 8435
 - 8436
 - 8437
 - 8438
 - 8439
 - 8440
 - 8441
 - 8442
 - 8443
 - 8444
 - 8445
 - 8446
 - 8447
 - 8448
 - 8449
 - 8450
 - 8451
 - 8452
 - 8453
 - 8454
 - 8455
 - 8456
 - 8457
 - 8458
 - 8459
 - 8460
 - 8461
 - 8462
 - 8463
 - 8464
 - 8465
 - 8466
 - 8467
 - 8468
 - 8469
 - 8470
 - 8471
 - 8472
 - 8473
 - 8474
 - 8475
 - 8476
 - 8477
 - 8478
 - 8479
 - 8480
 - 8481
 - 8482
 - 8483
 - 8484
 - 8485
 - 8486
 - 8487
 - 8488
 - 8489
 - 8490
 - 8491
 - 8492
 - 8493
 - 8494
 - 8495
 - 8496
 - 8497
 - 8498
 - 8499
 - 8500
 - 8501
 - 8502
 - 8503
 - 8504
 - 8505
 - 8506
 - 8507
 - 8508
 - 8509
 - 8510
 - 8511
 - 8512
 - 8513
 - 8514
 - 8515
 - 8516
 - 8517
 - 8518
 - 8519
 - 8520
 - 8521
 - 8522
 - 8523
 - 8524
 - 8525
 - 8526
 - 8527
 - 8528
 - 8529
 - 8530
 - 8531
 - 8532
 - 8533
 - 8534
 - 8535
 - 8536
 - 8537
 - 8538
 - 8539
 - 8540
 - 8541
 - 8542
 - 8543
 - 8544
 - 8545
 - 8546
 - 8547
 - 8548
 - 8549
 - 8550
 - 8551
 - 8552
 - 8553
 - 8554
 - 8555
 - 8556
 - 8557
 - 8558
 - 8559
 - 8560
 - 8561
 - 8562
 - 8563
 - 8564
 - 8565
 - 8566
 - 8567
 - 8568
 - 8569
 - 8570
 - 8571
 - 8572
 - 8573
 - 8574
 - 8575
 - 8576
 - 8577
 - 8578
 - 8579
 - 8580
 - 8581
 - 8582
 - 8583
 - 8584
 - 8585
 - 8586
 - 8587
 - 8588
 - 8589
 - 8590
 - 8591
 - 8592
 - 8593
 - 8594
 - 8595
 - 8596
 - 8597
 - 8598
 - 8599
 - 8600

- NOTES
- * ALL RESISTORS ARE IN OHMS, 1/4WATT UNLESS OTHERWISE NOTED.
 - * ALL CAPACITORS ARE IN μF , 50V UNLESS OTHERWISE NOTED.
 - * ELECTROLYTIC CAPACITORS (-4-) ARE IN μF , 16V.
 - * VOLTAGE (MEASURED WITH VTVM/NO INPUT SIGNAL).
 - * CIRCUIT IS SUBJECT TO CHANGE FOR IMPROVEMENT.
 - * WHEN YOU CHANGE SCAN STEP 1E AM BAND FROM 9KHZ TO 10KHZ, TAKE OFF THE DIODE.

PRE., AND POWER AMPLIFIER PC BOARD (NAAF-954)-PARTS LIST

CIRCUIT NO.	PARTS NO.	DESCRIPTION	D914	224096 or	GZA5.6U or
	ICs			224041	05Z5.6U
Q351, Q451	222534	NJM-4559DX	D951	223848	GP08B
Q501, Q601	222026	STK-3042 — 14.00	D952, D953	223105 or	1S1555 or
Q502, Q602	222025	STK-1050 — 18.00		223133	DS442X
Q503, Q603	222502 or	NJM-4558DX or		Coils	
	222597	NJM-4558DN	L501, L601	231001	S-1.3B
Q907	222780052	78M05		Capacitors	
	Transistors		C353, C453	352784799	0.47μF, 50V, Elect.
Q901	2211255	2SC1815 (GR)	C356, C456	352742209	22μF, 16V, Elect.
Q903	2211454	2SA1015 (Y)	C361, C461	352780109	1μF, 50V, Elect.
Q904, Q905	2211255	2SC1815 (GR)	C501, C601	352780109	1μF, 50V, Elect.
Q906	2200673 or	2SA816 (O) or	C504	352780109	1μF, 50V, Elect.
	2200674	2SA816 (Y)	C509, C510	352780479	4.7μF, 50V, Elect.
Q951, Q952	2211255	2SC1815 (GR)	C512-C515	352751009	10μF, 25V, Elect.
Q902	2210803 or	2SA733(P) or	C612-C615	352751009	10μF, 25V, Elect.
	2211454	2SA1015(Y)	C516, C517	352780339	3.3μF, 50V, Elect.
	Diodes		C903, C904	335251039	10,000μF, 50V, Elect.
D905, D906	223848	GP-08B	C905	352782219	220μF, 50V, Elect.
D907	223922 or	WZ-270 or	C906, C907	352761019	100μF, 35V, Elect.
	223979	RD27EB	C909	352751019	100μF, 25V, Elect.
D908	223909	WZ-310	C910	352782219	220μF, 50V, Elect.
D909	223862	WL01	C911-C912	352782209	22μF, 50V, Elect.
D911	223105 or	1S1555 or	C914	352751019	100μF, 25V, Elect.
	223133	DS442X	C908, C913	352754709	47μF, 25V, Elect.
D912, D913	223848	GP-08B			

EXPLODED VIEW

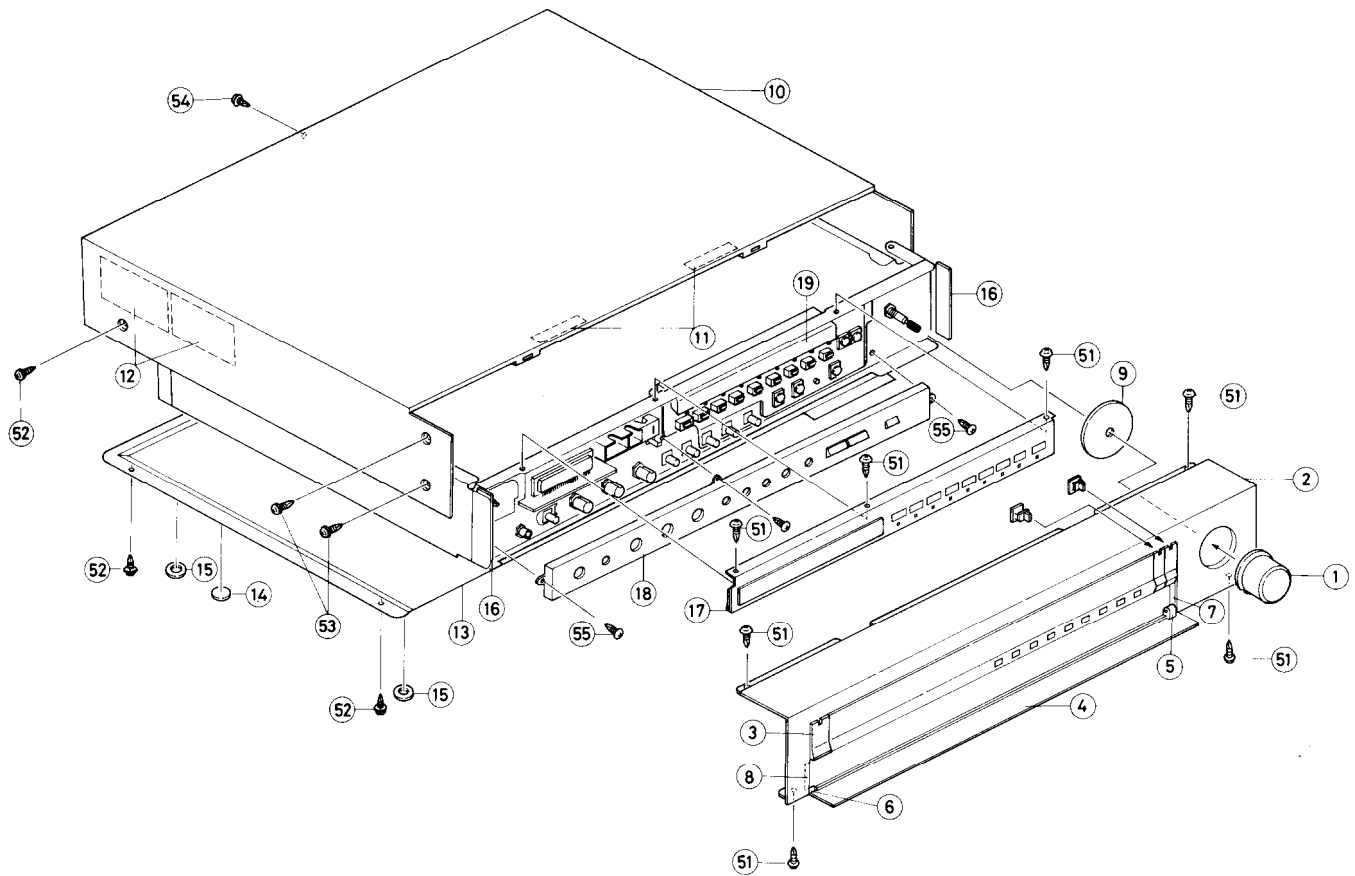

PARTS LIST

REF. NO.	PARTS NO.	DESCRIPTION
1	28320442	Knob, volume
2	13469121	Front panel ass'y
3	28320462	Knob, power
4	27180064B	Spring
4	27210196	Front panel, lid
5	27300315A	Bearing (R)
6	27300316A	Bearing (L)
7	27300334	Side plate (R)
8	27300335A	Side plate (L)
9	28140126	53φ, Cushion
10	28184095	Top cover
11	28140020	4 x 10 x 40mm, Cushion
12	28140111	4 x 25 x 60mm, Cushion
13	27170090	Bottom board
14	27175017	Leg
15	27175011B	Leg
16	28140302	3 x 60 x 10mm, Cushion
17	13469124	Plate (R) ass'y.
18	13469123	Plate ass'y
19	27267079	Lamp guide
51	834130062	3STS + 6BQ, Tapping screw
52	831130062	3STW + 6BQ, Tapping screw
53	834430102	3STS + 10BQ (BC), Tapping screw
54	834430062	3STS + 6BQ (BC), Tapping screw
55	834130062	3STS + 6BQ, Tapping screw

PACKING PROCEDURES

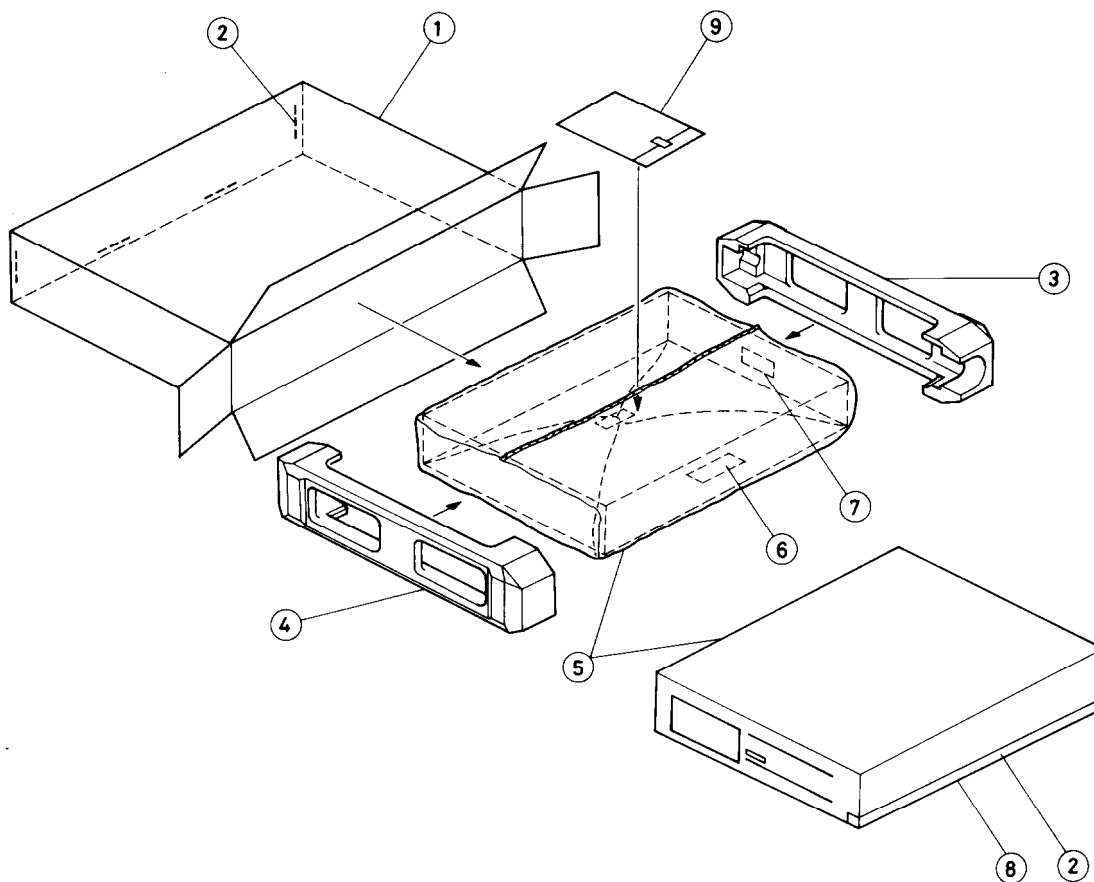

120V model

REF. NO.	PARTS NO.	DESCRIPTION
1	29050401	Master carton box
2	282301	Sealing hook
3	29090550	Pad (R)
4	29090549	Pad (L)
5	29100034A	650 x 850mm, Poly bag
6	29360363	Caution label (C)*
7	29360378	Label*
8	260012	Damplon tape
9		Accessory bag ass'y
	29340469	Instruction manual
	29365006	Warranty card*
	29358002	Service station list*
	292064A	5059-01, FM antenna
	29100006	250 x 350mm, Poly bag

* : Only U.S.A. model.

220V model

REF. NO.	PARTS NO.	DESCRIPTION
1	29050401	Master carton box
2	282301	Sealing hook
3	29090550	Pad (R)
4	29090549	Pad (L)
5	29100034A	650 x 850mm, Poly bag
8	260012	Damplon tape
9		Accessory bag ass'y
	29365005	Warranty card*
	29340468	Instruction manual
	292064A	5059-01, FM antenna
	29100006	250 x 350mm, Poly bag

* : Only West Germany model.

ONKYO CORPORATION

International Division : No. 24 Mori Bldg., 23-5, 3-chome Nishi-Shinbashi, Minato-ku, Tokyo Japan
Telex : 2423551 ONKYO J. Phone : 03-432-6981

ONKYO U.S.A. CORPORATION

Eastern Office
42-07 20th Avenue, Long Island City, New York 11105, U.S.A. Phone : (212) 728-4639
Midwest Office
935 Sivert Drive, Wooddale, Illinois 60191, U.S.A. Phone : (312) 595-2970
C/O Damark Industries Inc.
20520 Nordhoff Chatsworth, Cal. 91311, U.S.A. Phone : (213) 998-6501

ONKYO DEUTSCHLAND GMBH, ELECTRONICS

8034 München-Germering, Industriestrasse 18, West Germany. Telex : 521726

Telefon : (089) 845-5041