

ONKYO SERVICE MANUAL

QUARTZ SYNTHESIZED TUNER AMPLIFIER MODEL TX-35

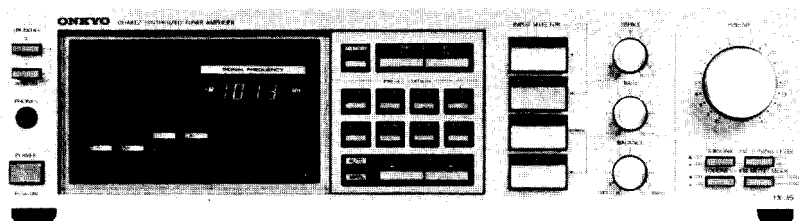

UD, UDN, BUD, BUDN	120V AC, 60Hz
UG, UGV, BUG, BUGV	220V AC, 50Hz
UW	120 or 220V AC, 50/60Hz
UQB	240V AC, 50Hz

Silver and black models

SAFETY-RELATED COMPONENT WARNING!!

COMPONENTS IDENTIFIED BY MARK \triangle ON THE SCHEMATIC DIAGRAM AND IN THE PARTS LIST ARE CRITICAL FOR RISK OF FIRE AND ELECTRIC SHOCK. REPLACE THESE COMPONENTS WITH ONKYO PARTS WHOSE PARTS NUMBERS APPEAR AS SHOWN IN THIS MANUAL.

MAKE LEAKAGE-CURRENT OR RESISTANCE MEASUREMENTS TO DETERMINE THAT EXPOSED PARTS ARE ACCEPTABLY INSULATED FROM THE SUPPLY CIRCUIT BEFORE RETURNING THE APPLIANCE TO THE CUSTOMER.

SPECIFICATIONS

AMPLIFIER SECTION

Power Output:	45 watts per channel, min. RMS, at 8 ohms, both channels driven, from 20 Hz to 20 kHz, with no more than 0.04% THD.
Music Power Output:	2 x 100 watts at 4 ohms, 1 kHz (DIN) 2 x 70 watts at 8 ohms, 1 kHz (DIN)
Continuous Power Output:	2 x 70 watts at 4 ohms, 1 kHz (DIN) 2 x 50 watts at 8 ohms, 1 kHz (DIN)
Total Harmonic Distortion:	0.04% at rated power 0.04% at 1 watt output
IM Distortion:	0.04% at rated power 0.04% at 1 watt output
Damping Factor:	35 at 8 ohms
Frequency Response:	20 - 30,000 Hz \pm 1 dB
RIAA Deviation:	20 - 20,000 Hz \pm 0.8 dB
Sensitivity and Impedance:	Phono: 2.5 mV/50 kohms Tape Play: 150 mV/50 kohms Tape Rec: 150 mV/3.5 kohms (phono)
Phono Overload:	180 mV RMS at 1kHz, 0.08% THD
Signal-to-Noise Ratio:	Phono: 85 dB (at 10 mV input, A weighted) 75 dB (IHF A-202) Tape: 95 dB (A weighted) 80 dB (IHF A-202)
Tone Controls:	Bass: \pm 8 dB at 100 Hz Treble: \pm 8 dB at 10 kHz
Loudness (-30 dB):	+7 dB at 70Hz, +5 dB at 10 kHz
Subsonic:	-6 dB at 15 Hz

ONKYO

AUDIO COMPONENTS

TUNER SECTION**FM:**

	120V model	220/240V model
Tuning Range:	87.5 – 108.0 MHz (100 kHz steps)	87.5 – 108.0 MHz (50 kHz steps)
Usable sensitivity:	Mono: 10.8 dBf, 1.9 μ V Stereo: 17.2 dBf, 4.0 μ V	Mono: 10.8 dBf, 1.9 μ V Stereo: 17.2 dBf, 4.0 μ V
50 dB Quieting Sensitivity:	Mono: 17.2 dBf, 4.0 μ V Stereo: 37.2 dBf, 40 μ V	Mono: 17.2 dBf, 4.0 μ V Stereo: 37.2 dBf, 40 μ V
Capture Ratio:	1.5 dB	1.5dB
Image Rejection Ratio:	40 dB	85 dB
IF Rejection Ratio:	90 dB	90 dB
Signal-to Noise Ratio:	Mono: 72 dB Stereo: 67 dB	Mono: 72 dB Stereo: 67 dB
Selectivity:	55 dB	50 dB DIN (\pm 300 kHz 40 kHz dev.)
AM Suppression Ratio:	50 dB	50 dB
Harmonic Distortion:	Mono: 0.15% Stereo: 0.25%	Mono: 0.15% Stereo: 0.25%
Frequency Response:	30 – 15,000 Hz \pm 1.5 dB	30 – 15,000 Hz \pm 1.5 dB
Stereo Separation:	40 dB at 1 kHz 30 dB at 100 – 10,000 Hz	40 dB at 1 kHz 30 dB at 100 – 10,000 Hz
Tuning Level (Hi/Lo):	23.2 dBf, 8 μ V/17.2 dBf, 4 μ V	23.2 dBf, 8 μ V/17.2 dBf, 4 μ V
Stereo Threshold:	23.2 dBf, 8 μ V/17.2 dBf, 4 μ V	23.2 dBf, 8 μ V/17.2 dBf, 4 μ V

AM:

Tuning Range:	520 – 1,710 kHz (10 kHz steps)	522 – 1,611 kHz (9 kHz steps)
Usable Sensitivity:	30 μ V	30 μ V
Image Rejection Ratio:	40 dB	40 dB
IF Rejection Ratio:	30 dB	30 dB
Signal-to-Noise Ratio:	40 dB	40 dB
Harmonic Distortion:	0.8%	0.8%

GENERAL:

Semiconductors:	EETs: 6 TR: 30 ICs: 10 Diodes: 74	EETs: 6 TR: 34 ICs: 10 Diodes: 79
Dimensions (WxHxD):	418 x 112 x 340 mm (16 1/2" x 4 1/2" x 13 3/8")	418 x 112 x 340 mm (16 1/2" x 4 1/2" x 13 3/8")
Weight:	7.3 kg., 16.1 lbs.	7.3 kg., 16.1 lbs.

TABLE OF CONTENTS

Specifications	1	Pc board parts list and view from component side	
Service procedures	3	FM/AM tuner pc board	19
Block diagram – Amplifier section–	4	Digital circuit pc board	23
Block diagram –D (120V) model–	5	Fluorescent indicator tube pc board	23
Block diagram –G (220V) and Q (240V) models–	6	Tuner switch pc board	24
Block diagram –W (120 or 220V) model–	7	Power supply and amplifier pc board	27
Exploded view	8	Speaker switch pc board	27
Parts list	9	Fuse terminal pc board	27
Circuit description	10	Equalizer amplifier pc board	31
Adjustment procedures	15	Tone control/Switch pc boards	32
Schematic diagram of tuner section		Block diagram of IC	35
–W model –	17	Packing view	36
–D model–	21		
–G/Q models–	25		
Schematic diagram of amplifier section			
–D/W models–	27		
–G/Q models–	29		

SERVICE PROCEDURES

1. Replacing the fuses

For continued protection against fire hazard, replace only with same type and same rating fuse.

D (120V) model

Circuit no.	Parts no.	Description
F501, F601	252059	4A (SS-2), Speaker
F901	252049	4A (ST-6), Primary

G (220V) and Q (240V) models

Circuit no.	Parts no.	Description
F501, F601	252077	4A-SE-EAK, Speaker
F902	252074	2A-SE-EAK, Primary
F903, F904	252078	5A-SE-EAK, Secondary
F905, F906	252070	1A-SE-EAK, Secondary
F907	252088	0.25A-SE-EAK, Secondary

W(120 or 220V) model

Circuit no.	Parts no.	Description
F501, F601	252014	4A-T, Speaker
F901	252014	4A-T, Primary
F902	252074	2A-SE-EAK, Secondary

2. Replacing the lamps

This unit uses the lamps listed below.

Circuit no.	Parts no.	Description
PL901, PL902	210162	PL 6.3V, 250mA, Dial plate illumination

Remove the top cover.

Remove the front panel.

Remove the holder.

(See fig. 2)

3. Insulation resistance measurement

Connect the insulating-resistance tester between the plug of power supply cable and terminal GND.

Specifications: D model: $3.3 \pm 0.3M$ ohm

Other models: More than 10Mohm

4. Disassembling procedures

Selector switch pc board

Remove the top cover.

Remove the all screws on the back panel.

Remove a screw holding the radiator and bracket, pcb.

5. Change of AM scan step

W models are equipped with a switch to change the AM scan step frequency from 9kHz to 10kHz. The switch is located on the back panel. This switch is set to 9kHz at the factory; change to 10kHz if gives better results in your locality.

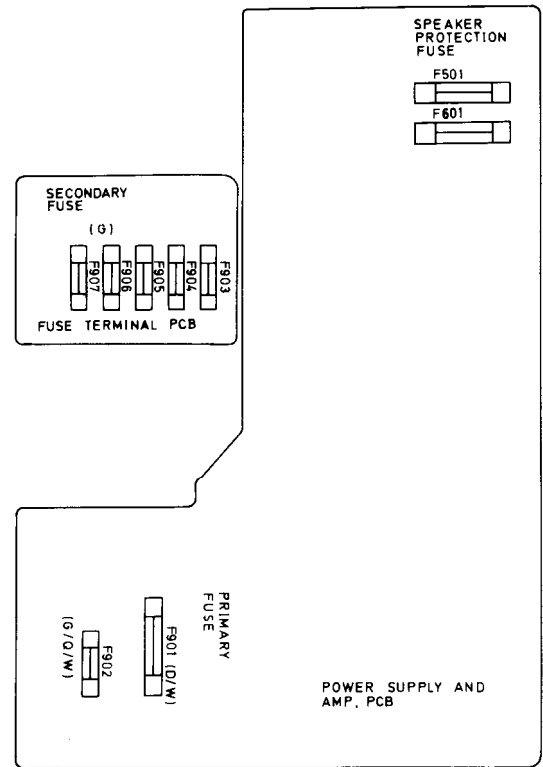

(fig. 1)

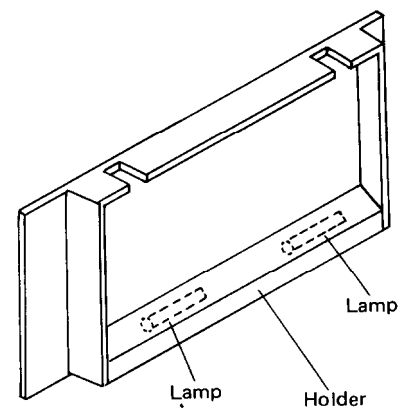

(fig. 2)

6. Change of De-emphasis

W models are equipped with a $50\mu\text{sec}$ - $75\mu\text{sec}$ selector switch. This switch is located on the back panel. This switch is set to $50\mu\text{sec}$ at the factory, but may have to be reset to $75\mu\text{sec}$ depending on the area where the unit is used.

Europe: $50\mu\text{sec}$

U.S.A.: $75\mu\text{sec}$

7. Change of voltage

W models are equipped with a voltage selector to conform with local power supplies. This switch is located on the back panel. Be sure to set this switch to match the voltage of the power supply in your area before turning the power switch on.

This switch is set to 220V at the factory. Voltage is changed by sliding the groove in the switch with the screwdriver to the right or left. Confirm that the switch has been moved all the way to the right or left before turning the power switch on.

8. Memory Preservation

This unit does not require memory preservation batteries. A built-in memory power back-up system preserves contents of the memory during power failures and even when the unit is unplugged. The unit must be plugged in and the power switch turned on and off once in order to charge the back-up system. Note that since this is not a permanent memory, the power switch must be turned on and off a few times each month to keep the back-up system operable. The period of time during which memory contents are preserved after power has last been turned off varies depending on climate and the location and placement of the unit. On the average, memory contents are protected over a period of 3 to 4 weeks (a minimum of 2 weeks) after the last time power has been turned off. This period is shorter when the unit is exposed to very high humidity or used in an area with an extremely humid climate.

BLOCK DIAGRAM

Amplifier section

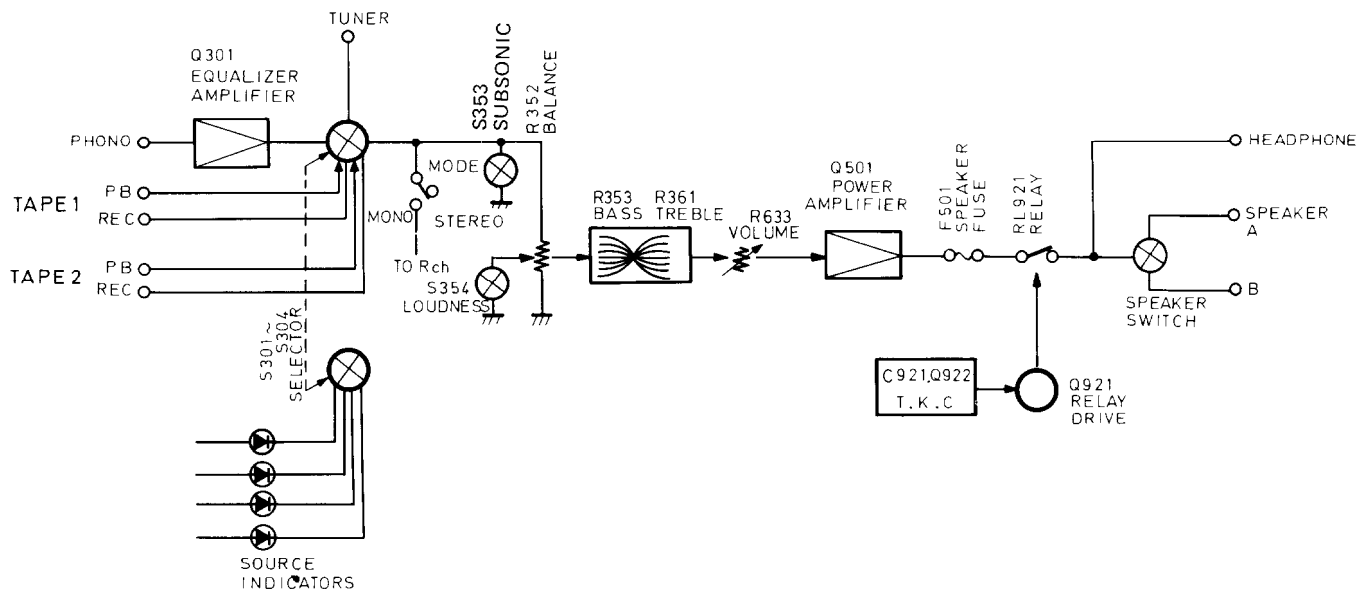

BLOCK DIAGRAM

-D model-

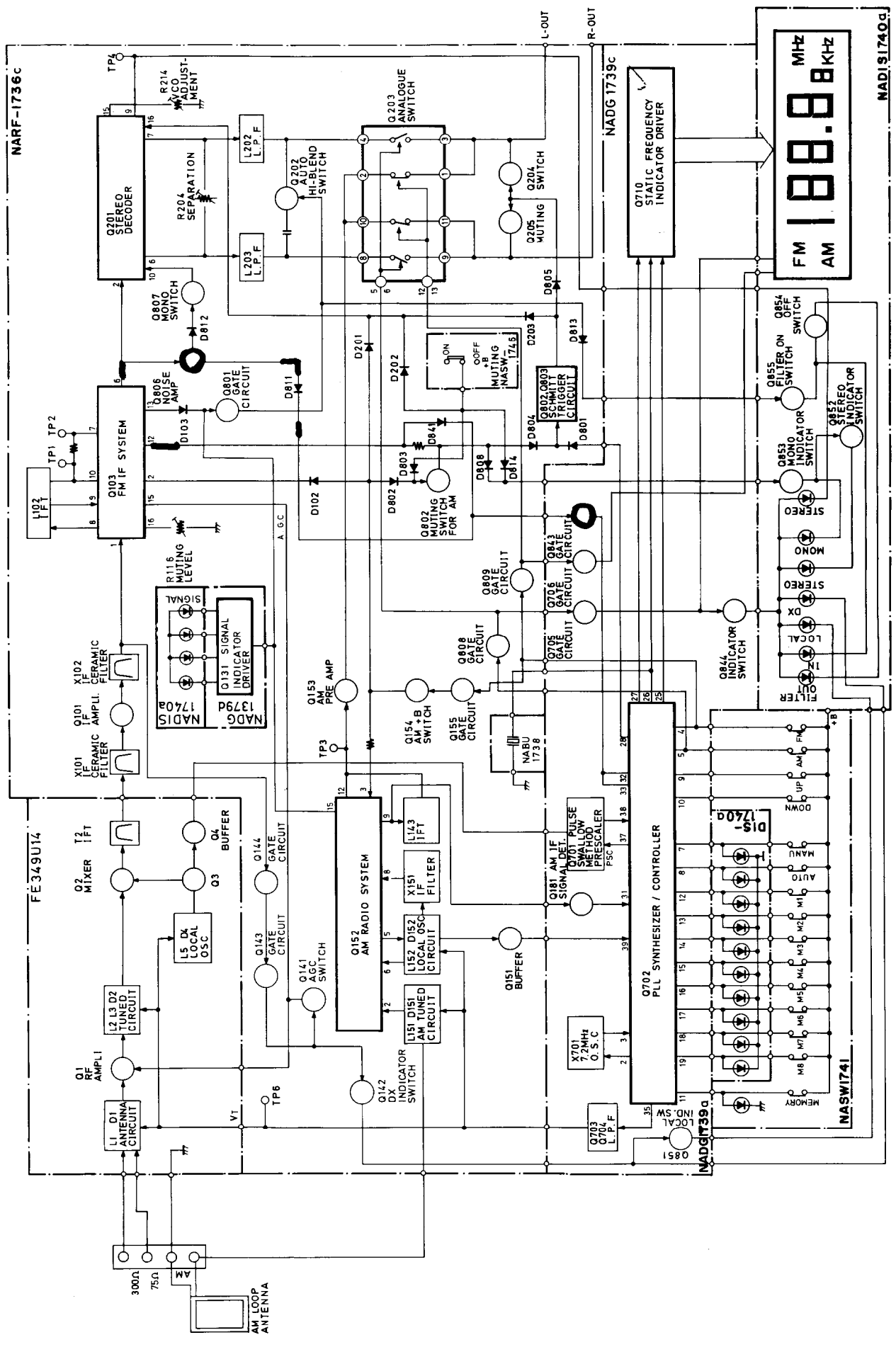

BLOCK DIAGRAM

-G model-

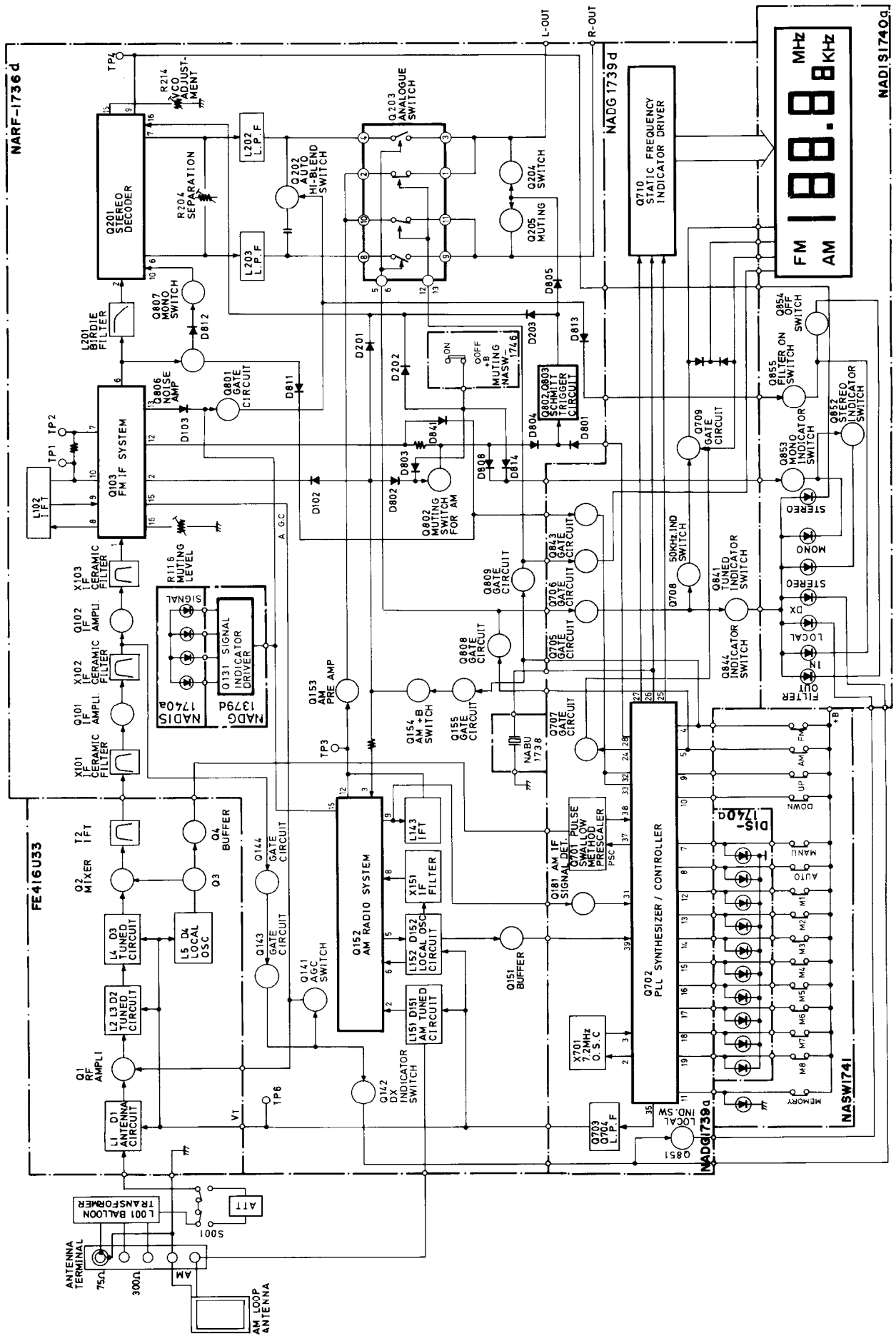

BLOCK DIAGRAM

-W model-

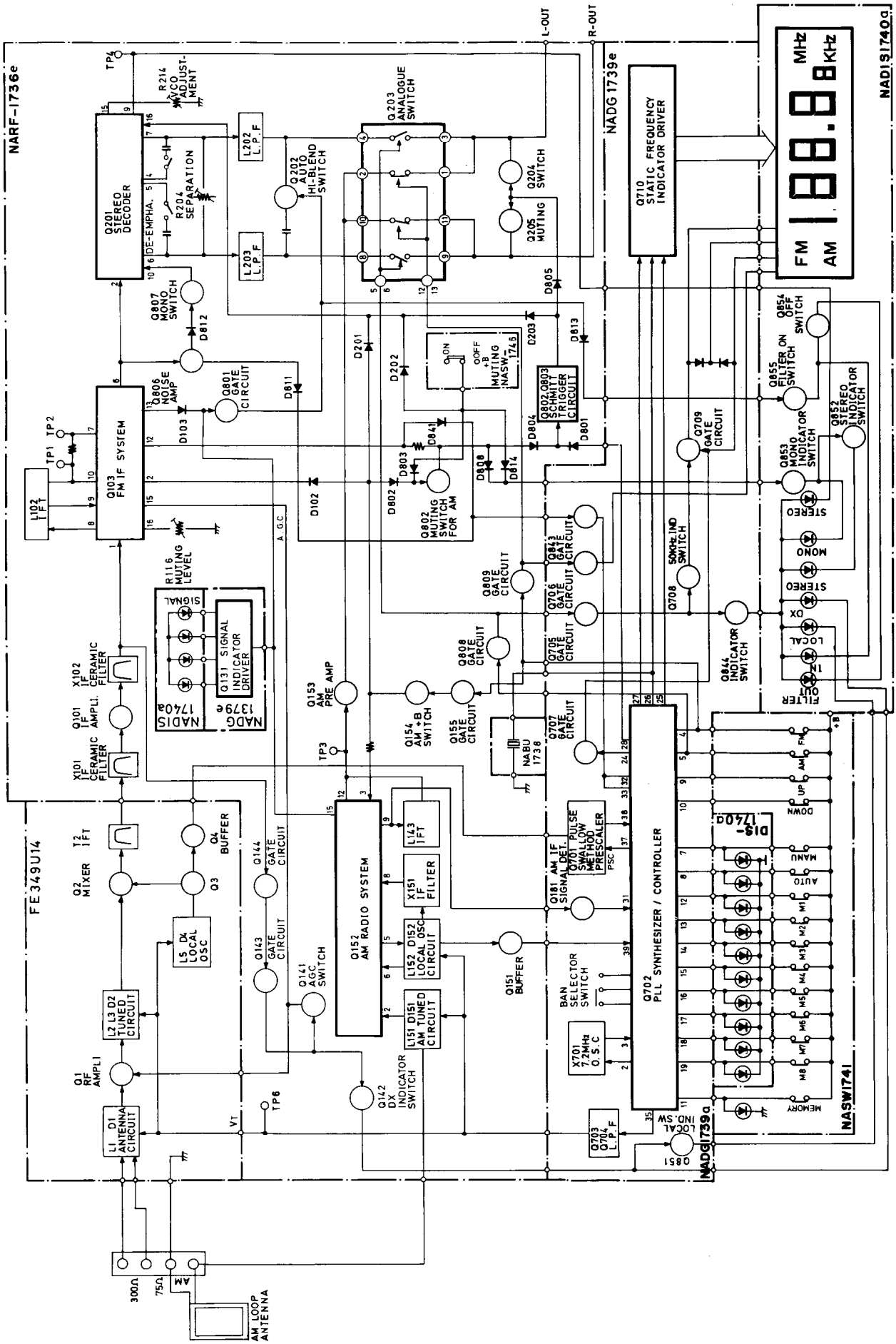

EXPLODED VIEW

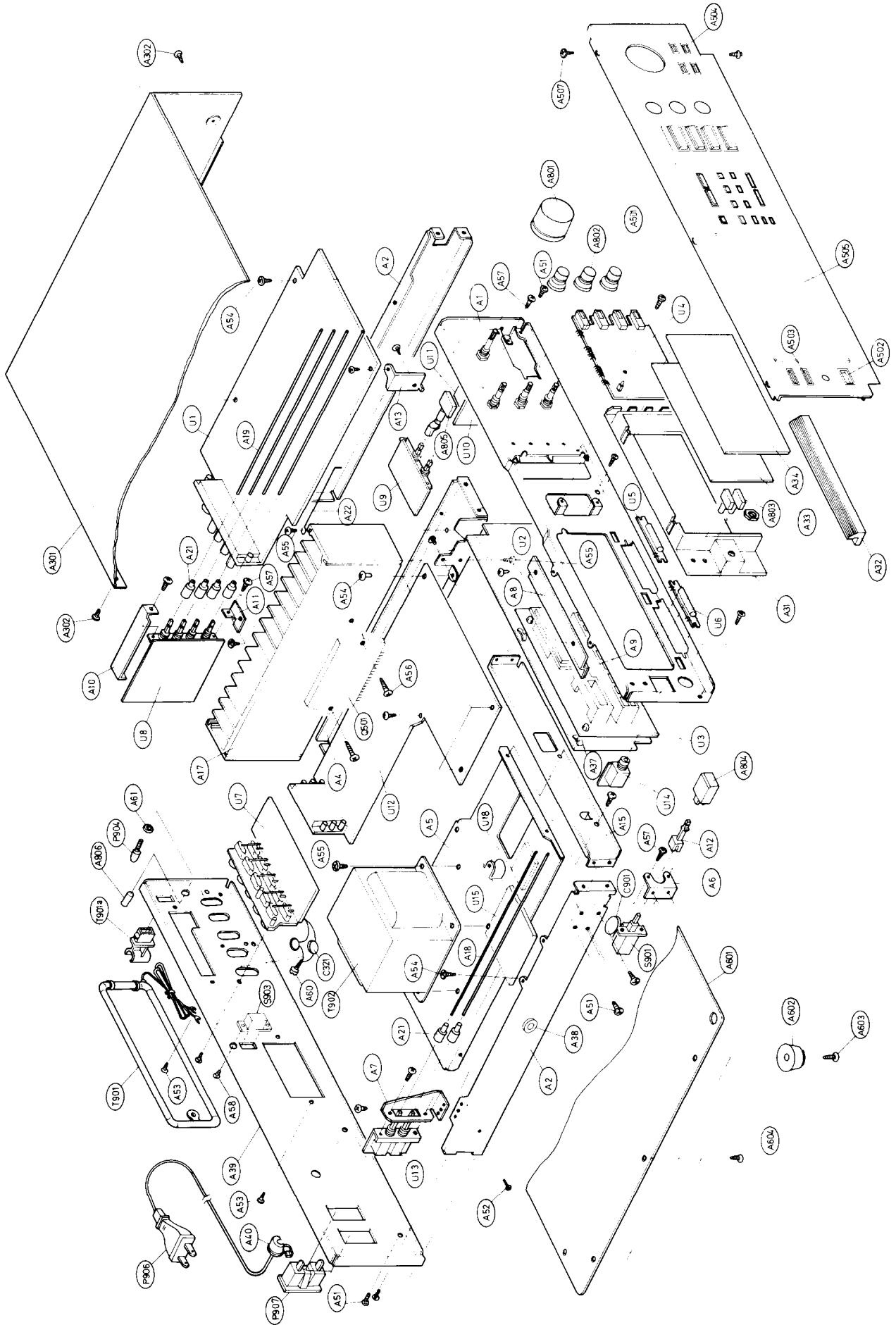

PARTS LIST

REF. NO.	PARTS NO.	DESCRIPTION	REF. NO.	PARTS NO.	DESCRIPTION	REF. NO.	PARTS NO.	DESCRIPTION
A1	27110202-1	Front bracket	A507	834430068	3TTS+6B (BC), Tapping screw	U2	18050536E	NARF-1736e, FM/AM tuner pc board ass'y (W)
A2	27115145A	Side bracket	A601	27170160	Bottom board		18048539C	NADG-1739c, Digital circuit pc board ass'y (D)
A4	27130339A	Bracket, radiator	A602	27175009A	Leg		18054539D	NADG-1739d, Digital circuit pc board ass'y (G/Q)
A5	27130340	Bracket, power transformer	A603	834430128	3TTS+12B (BC), Tapping screw	U3	18050539E	NADG-1739e, Digital circuit pc board ass'y (W)
A6	27140805	Bracket, power	A604	831430088	3TTW+8B (BC), Tapping screw		18048540A	NADIS-1740a, Fluorescent indicator tube pc board ass'y
A7	27140806	Bracket, speaker	A801	28320543-1	Knob, volume	U4	18008541	NASW-1741, Tuner switch circuit pc board ass'y
A8	27140807	Bracket, holder	A802	28320892	Knob, volume (B)		18008543	NAPL-1743, Dial plate illumination lamp pc board ass'y
A9	28140260	1.5x10x100mm, Cushion	A803	28321205	Knob, balance	U5	18008544	NAPL-1744, Dial plate illumination lamp pc board ass'y
A10	27140808	Bracket, selector	A804	28321206	Knob, balance (B)		18008545	NAEQ-1745, Equalizer amplifier pc board ass'y (D/W)
A11	27140809	Bracket S	A805	28321207	Knob, push	U8	18008546	NASW-1746, Selector switch pc board ass'y
A12	27260062	Shaft, switch	A806	28321208	Knob, push (B)	U9	18048547A	NASW-1747a, Switch pc board ass'y
A13	27140810A	Bracket, pcb	A804	28322082	Knob, power	U10	18008548	NATC-1748, Tone control circuit pc board ass'y
A15	27130341	Bracket F	A805	28321160	Knob, power (B)	U11	18008549	NAVY-1749, Volume control pc board ass'y
A17	27160133	Radiator	A805	28321215	Knob, push	U12	18048550C	NAAF-1750c, Power supply and power amplifier circuit pc board ass'y (D)
A18	27260123	Shaft	A806	28321216	Knob, push (B)		18054550D	NAAF-1750d, Power supply and power amplifier circuit pc board ass'y (G/Q)
A19	27260124	Shaft	△ C901	3500065A	Capacitor IS		18050550E	NAAF-1750e, Power supply and power amplifier circuit pc board ass'y (W)
A21	28320135	Connector	△ C901a	27300601	Cover for C901	U13	18008551A	NASW-1751a, Speaker selector switch pc board ass'y
A22	27300656	Holder, lead wire	C321, C322	330924730	0.047µF, 50V, Capacitor, ceramic (D)	U14	18008552	NAPP-1752, Headphone terminal pc board ass'y
A31	27190220	Holder, pcb	△ F501, F601	252059	4A (SS-2), Fuse, speaker protection (D)	U15	18034553	NAFU-1753, Fuse terminal pc board ass'y (G/Q)
A32	27190221	Holder, lamp	△ F501, F601	252077	4A-SE-EAK, Fuse, speaker protection (G/Q)	U16	18010537	NASW-1737, De-emphasis switch pc board ass'y (W)
A33	28133081-1	Back plate	△ F501, F601	252014	4A (ST-6), Fuse, primary (D)	U17	18010542	NASW-1742, Band selector switch pc board ass'y (W)
A34	28130197-1	Dial plate	△ F901, F901	252014	4A-T, Fuse, primary (W)	U18	180485538	NABU-1738, Buzzer pc board ass'y
A37	27190011	Holder	△ F902, F904	252078	2A-SI-EAK, Fuse, primary (G/Q/W)			
A38	27175011C	Leg	△ F903, F904	252078	5A-SE-EAK, Fuse, secondary (G/Q)			
A39	27120529B	Back panel (D)	△ F905, F906	252070	1A-SE-EAK, Fuse, secondary (G/Q)			
A51	834430068	3TTS+6B (BC), Tapping screw	△ F907	252088	0.25A-SE-EAWK, Fuse, secondary (G/Q)			
A52	838430068	3TTB+6B (BC), Tapping screw	P904	25060044	Ground terminal			
A53	833430108	3TTW+10B (BC), Tapping screw	△ P906	253112	AS-UC-4#18, Power supply cable (D)			
A54	831430088	3TTW+8B (BC), Tapping screw	△	253083-1	AS-CEE, Power supply cable (G/W)			
A55	838440089	4TTB+8C (BC), Tapping screw	△	728320	Power supply cable (Q)			
A56	834430168	3TTS+16B (BC), Tapping screw	△ P907, P908	25050046	NSCT-2P15, AC outlet terminal (D)			
A57	82143006	3P+6FN (BC), Pan head screw	Q501, Q601	222036	STK4893, Power amplifier IC			
A60	834230108	3TTS+10B (NI), Tapping screw	△ S901	25035398	NPS-111-L362P, Power switch			
A61	87613010	W3x10F, Washer	△ S902	25065123	NPS-1258P, Voltage switch (W)			
A61	28184201	Top cover	△ S903	250142	NSS-2225, Buzzer switch			
A301	28184202	Top cover (B)	T901	232085	NMA-3034, AM loop antenna			
A302	838430068	3TTS+6B (BC), Tapping screw	T901a	27190105	Antenna holder			
A501	18048121	Front panel ass'y	△ T902	230746	NPT-818D, Power transformer (D)			
	27267215	Guide, power	△	230747	NPT-818G, Power transformer (G)			
	27267280	Guide, speaker	△	230748	NPT-818DQ, Power transformer (W)			
	27267282	Guide, push	△	18048536C	NARF-1736c, FM/AM tuner pc board ass'y (D)			
	28191201	Clear plate	△	18054536D	NARF-1736d, FM/AM tuner pc board ass'y (G/Q)			
A501	28321209-1	Knob ass'y	U1					
	28321201	Front panel ass'y (B)						
	28191202	Clear plate						
	28321210	Knob ass'y						

NOTE: THE COMPONENTS IDENTIFIED BY MARK △ ARE CRITICAL FOR LISK OF FIRE AND ELECTRIC SHOCK. REPLACE ONLY WITH PARTS NUMBER SPECIFIED.

Notes: (D): Only 120V model
(G): Only 220V model
(W): Only 120/220V model
(Q): Only 240V model

CIRCUIT DESCRIPTIONS

1. Synthesizer and controller operation

Pin No.	Symbol	Terminal	Description
1	GND	Ground	
2	XT	X'tal	Connected to the 7.2MHz crystal oscillator for the reference frequency.
3	XT		
4	FM	FM band specification input	Mutual reset type, performs switching of each band, FM/MW/LW.
5	MW	MW band specification input	
6	LW	LW band specification input	
7	MANUAL	Manual tuning mode specification input	Mutual reset type, performs auto search and manual operation mode switching during UP/DOWN tuning.
8	AUTO	Auto search tuning mode specification input	
9	UP	UP tuning key input	Connect the push key and perform UP/DOWN tuning.
10	DOWN	DOWN tuning key input	
11	STO	Memory store command input	The preset memory is set to the write mode when the key is pressed.
12-19	M1-M8	Preset memory channel specification input	Controls the write and read out of the internal 16-station preset memory along with the MC1 and MC2 input.
20	MC-1	Memory control input	Set the 16-station preset memory to the 8 FM/8 AM station mode or the FM/MW/LW 3-band 16-station random mode. The 8 FM/8 AM mode is used in this unit.
21	MC-2		
22	OSC2	AM oscillator terminal	CR connection terminal for the oscillator that determines the scan speed during the AM search mode.
23	OSC1	FM oscillator terminal	CR connection terminal for the oscillator that determines the scan speed during the FM search mode.
24	0/5	FM 50 kHz output	Output that represents the 50kHz FM band tuning step for European models. Goes to the high level for the 50 kHz setting.
25	CK2	Tuned frequency data output	Outputs the serial data and timing clock to the tuned frequency display driver.
26	CK1		
27	DATA		
28	MUTE	Muting signal output	Goes to the high level during muting output.
29	E2	Regin specification input	See table 1.
30	E1		
31	STOP 3	AM IF signal input	During AM reception, this counts the IF signal and stops auto search.
32	STOP 2	Auto search stop signal input	When the stop 1 input (pin 33) is at the high level and this terminal goes to the high level, auto search is stopped.
33	STOP 1	Scan speed slow input	When the high level is input at this terminal, the auto search speed is cut in half.

Pin No.	Symbol	Terminal	Description
34	DO1	Error output	Charge pump output of the phase detector which constitutes the PLL. High level is output when the divided oscillation frequency is high than the reference frequency. In the opposite case, low level is output. Floating occurs when the frequencies match. The output is applied to the variable capacitor diode in the front end through low pass filter Q703 and Q704. The output from both terminals is the same, but only DO1 is used.
35	DO2		
36	TEST	Test terminal	Test mode at the high level.
37	FM IN	FM programmable counter input	Connect to the prescaler output (Pin3 of Q701)
38	PSC	Pulse swallow control output	Output to the control the division ratio of the prescaler.
39	AM IN	AM local oscillator signal input	Terminal for input of AM broadcast signal.
40	$\overline{\text{INH}}$	Inhibit input	Operates normally at the high level. Inhibit status at the low level.
41	$\overline{\text{INT}}$	Initialize input	Operates normally at the high level. At the low level, the internal status is initialized.
42	V _{DD}	Power supply	Device power terminal; supplies 5V during the normal operation and 2.5V from the super capacitor (C715) for memory preservation.

table 1.

E1 (Pin 30)	E2 (Pin 29)	Regin	Band	Frequency range	Intermediate frequency	Scan step	Reference frequency
0	1	U.S.A	FM	87.5 ~ 108.0 MHz	+10.7 MHz	100 kHz	25 kHz
			AM1	520 ~ 1 710 kHz	+450 kHz	10kHz	10 kHz
1	1		AM2	522 ~ 1 710 kHz	+450 kHz	9kHz	9kHz
1	0	Europe	FM	87.50 ~ 108.00 MHz	+10.7 MHz	50 kHz	25 kHz
			MW	522 ~ 1611 kHz	+450 kHz	9 kHz	9 kHz
			LM	153 ~ 360 kHz	+450 kHz	1 kHz	1 kHz
0	0	Japan	FM	76.0 ~ 90.0 MHz	-10.7 MHz	100 kHz	25 kHz
			AM	522 ~ 1611 kHz	+450 kHz	9 kHz	9 kHz

2. Auto-Hi-blend circuit

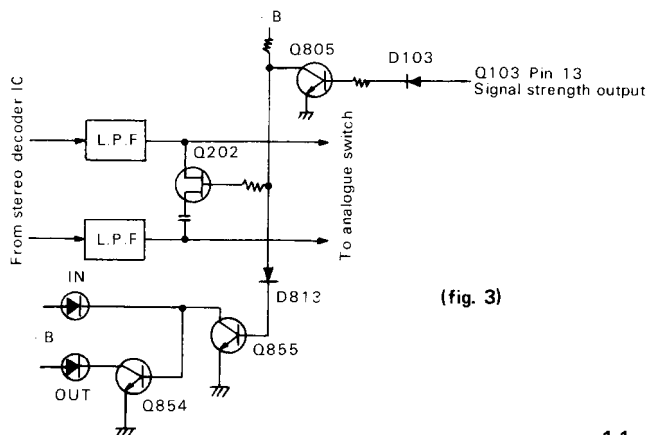

(fig. 3)

There is a 3-stage IF level detection circuit in the IC of Q103. A direct current voltage approximately proportional to the electrical field intensity is output from output pin 13. This is used to turn off Q805 and turn on Q202 when the electrical field is weak and, making use of the fact that the phase of noise components in the high range of stereo broadcasts is reversed left-right, the left and right channels are mixed in the high range to reduce noise. At the same time, Q855 is turned on and Q854 is turned off, and the IN LED of filter lights on.

3. Auto-search tuning circuit

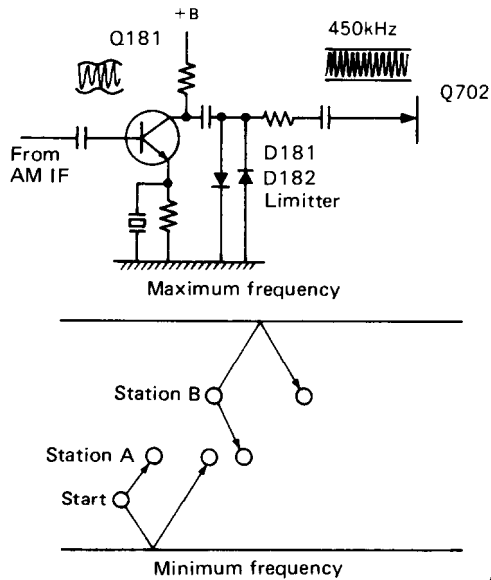
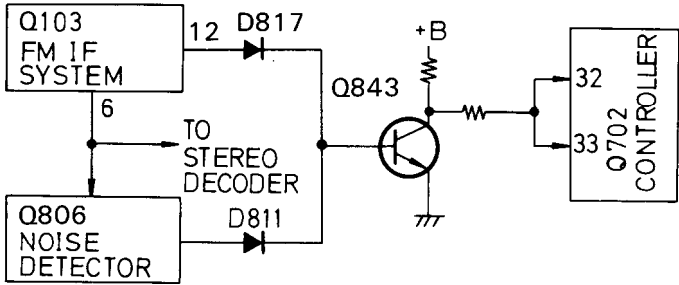

(fig. 4)

4. FM/AM selector circuit

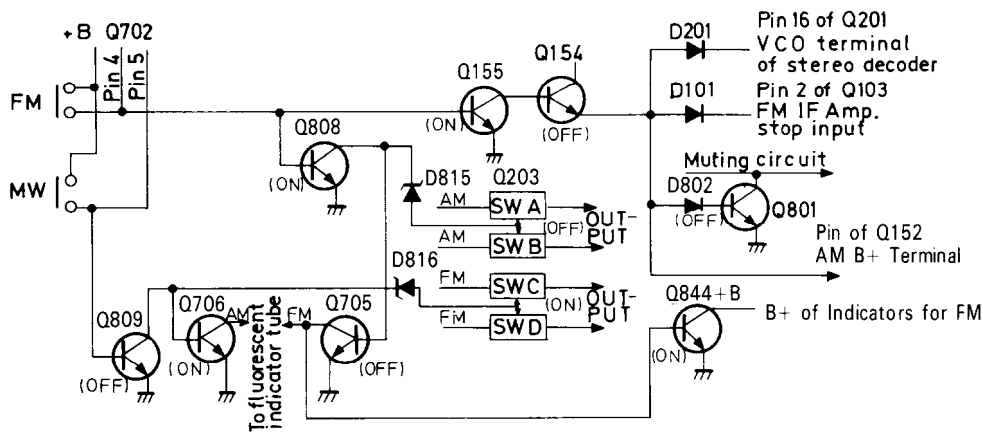

(fig. 5)

The FM/AM selector circuit is shown in the diagram, fig. 5. Pins 4 and 5 of Q702 are of the mutual reset type. For FM, pin 4 is high and pin 5 is low; for AM, pin 4 is low and pin 5 is high. Because pin 5 is high and pin 4 is low during AM reception, Q809 is on and Q808 is off, the analogue switches SW1 and SW2 of Q203 are on while SW3 and SW4 are off, so an AM signal is output. Also, since Q706 goes to on and Q705 to off, the AM, kHz segments of the fluorescent display are turned on. Q844 goes to off so the FM indicators is turned off. At the same time, Q155 is turned

During FM reception, this is operated by the IF level detection and zero point detection circuits included in the FM IF system IC of Q103 and by the noise component detection circuit of Q806. When a station is tuned, the output of all outputs go to the low level so Q843 goes from on to off, causing pins 32 and 33 of the controller IC to go to the high level to complete auto search tuning.

During AM reception, the AM IF signal is taken, amplified by Q181, limited to a certain amplitude by the D181 D182 limiter circuits and auto search tuning is completed when the IF signal becomes 450 ± 3 kHz.

- **Manual Tuning**

When the UP or DOWN key is pressed, the frequency goes up or down by one step. When either key is held down, the frequency rapidly increases or decreases (scans) and stops when the key is released. When either end of the tuning range is reached, key input will no longer be received and the frequency will stop at the highest or lowest frequency.

- **Auto Tuning**

When the UP or DOWN key is pressed, scanning begins in the up or down direction, stopping where there is a radio station. Since auto scan is operated by a triangular wave, scanning is begun in the opposite direction the instant either end of the tuning range is reached. Also, if the UP or DOWN key is pressed when the tuned frequency is not at either end of the range, up or down scanning will begin.

off and Q154 turned on, so +B is supplied to the power source terminal of the radio system pin 3 of Q152.

Pin 16 of Q201 goes to the high level, the VCO oscillator stops, and pin 2 of Q103 goes to the high level so the FM IF amp is also switched off. Also, during AM reception, Q801 is turned on so the muting circuit is off. During FM reception, all of the switching transistors mentioned above perform the opposite operations to switch to the FM mode. Figures in parentheses indicate transistor operation during FM reception.

5. PLL tuned circuit

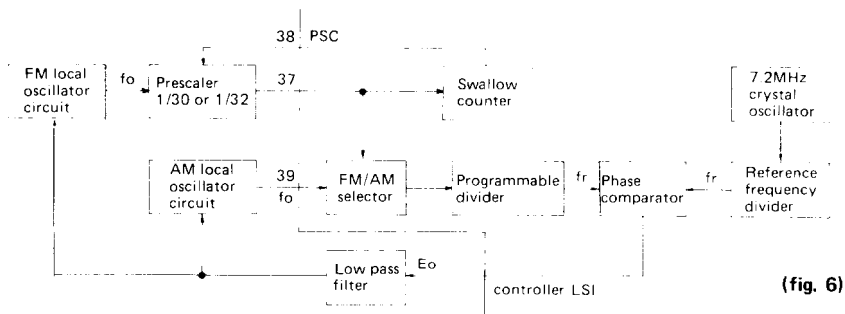

(fig. 6)

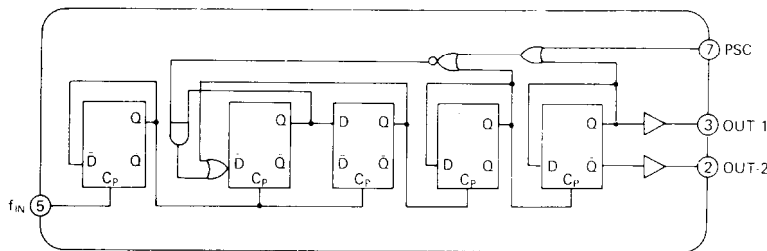

(fig. 7) TD6104P (Prescaler)

A block diagram of the tuned circuit of the PLL is shown in figer 6.

Operation during AM reception

The reception frequency is applied to the programmable divider where it is divided to $1/N$ and output as f_v . This is applied to the phase comparator where it is compared with frequency reference f_r (9kHz for G/W model and 10kHz for D model). If f_r and f_v differ, E_o equal to the difference in frequency is output. Since error output E_o is a pulse waveform, it is passed through the low pass filter to change it into DC voltage V_D , which is applied to the variable capacitor diode in the front end to change the reception frequency. This continues until f_v and f_r are the same and $E_o=0$.

Operation during FM reception

The pulse swallow method is used in the prescaler of this unit. In this type of prescaler, a supplementary number

(changed according to the program code input) and the divided reception frequency from the prescaler are combined in the control counter and the prescaler's division factor is switched $1/30$ or $1/32$ according to external control ($1/32$ when the PSC terminal is "H" and $1/30$ when it is "L").

The station oscillator frequency is applied ot the program- mable divider, but the programmable divider has en upper frequency limit of only 30MHz, so the pulse swallow-type prescaler, which can be used up to 150 MHz, is inserted for division to $1/N_p$;

The signal is applied to the programmable divider and divided to $1/N$. The result is compared with a 25kHz frequency reference in the phase detector and the error is output as E_o until a match is obtained as in AM operation.

6. Frequency indicator circuit

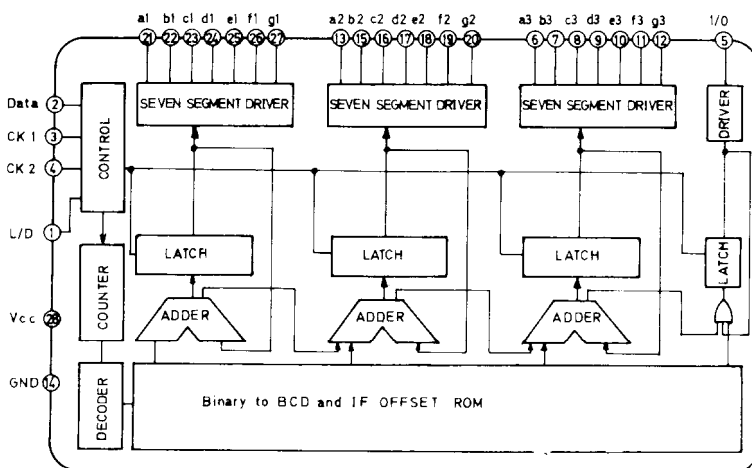

(fig. 8) TD6301AP block diagram

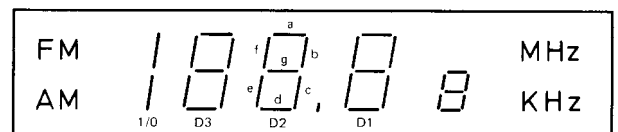

Pin No.	Terminal	Description
1	L/D	Output indication switching input terminal: Fluorescent display at the low level, and LED display at the high level.
2	Data	Tuned frequency data input terminal: Input from the system controller LSI to the serial.
3,4	CK1, CK2	Tuned frequency data input control timing input terminal: Transferred simultaneously with data from the system controller LSI.
5	I/O	Segment drive output terminal: Sets the number of display digit for FM (100MHz) and AM (1,000kHz) reception.
6-12	a3-g3	Seven segment drive output terminals: Sets the number of display digit for FM(10MHz) and AM (100kHz) reception.
13, 15-20	a2-g2	Seven segment drive output terminals: Sets the number of display digit for FM (1MHz) and AM (10kHz) reception
21-27	a1-g1	Seven segment drive output terminals; set the number of display digit for FM (100kHz) and AM (1kHz) reception
14	V _{CC}	Power source terminal
28	Gnd	Ground

7. Muting circuit

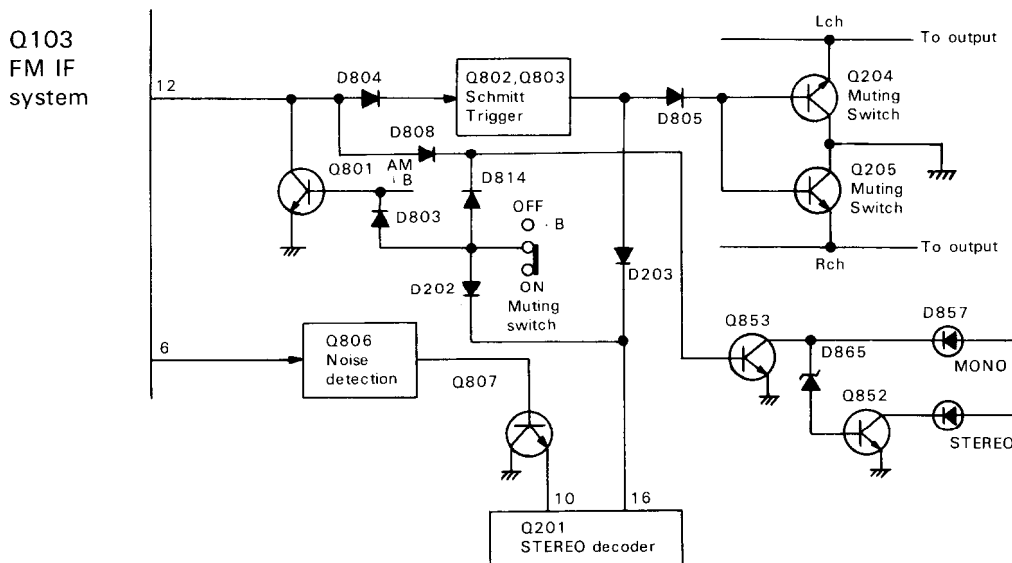

The muting circuit operates in the following cases.

- While pin 28 of the controller IC outputs the high level, Q204 and Q205 are turned on and muting is closed in the following cases: (1) While the manual UP/DOWN switch is being held down, (2) When a station in the memory is recalled, and (3) While a radio station is being received using auto search tuning.
- When an FM station is not being received (and the muting switch is on).

The IF level in the FM IF system (set at R116 so muting is opened at 17 dBf) and zero point detection circuit (tuning point $35 \pm 15\text{kHz}$) are output at pin 12 through

the AND circuit. When a station is tuned, the output goes to the low level.

When output goes to the low level, Q802 is turned off, Q803 is turned on and Q203 and Q204 are turned off, so muting is opened. At the same time, pin 16 of stereo decoder Q201 goes to the low level, so the VCO oscillator starts.

ADJUSTMENT PROCEDURES

FM section

Item	Step	Connection of instrument	FM SG output	Stereo modulator output	Turning dial setting	Output indicator	Adjustment	Adjust for	Remarks
FM RF	1	Fig. 1	—	—	88.0 MHz	Digital DC voltmeter	T1	1.4V	
	2	Fig. 1	107.9 MHz 1 kHz, 75 kHz devi.	—	107.9 MHz	AC voltmeter	C7, C9 (G)	Maximum output	
FM IF	1	Fig. 2	—	—	No input signal	DC voltmeter	L101 Primary coil	0V	Repeat the steps 1 and 2 until no further adjustment is necessary
	2	Fig. 2	98.1 MHz 1 kHz, 75 kHz devi. 65 dBf (60 dB)	—	98.1 MHz	Distortion analyzer	L101 Secondary coil	Minimum	
VCO	1	Fig. 3	98.1 MHz No modulation 65 dBf (60 dB)	—	98.1 MHz	Frequency counter	R214	76 kHz ± 76 Hz	Remove the frequency counter after adjustment
	2	Fig. 3	98.1 MHz 65 dBf (60 dB) Ext. modulation	L ch. 1 kHz R ch. 1 kHz	98.1 MHz	R ch. AC voltmeter L ch. AC voltmeter	R204	Minimum Minimum	Maximum and same separation
Distortion	1	Fig. 3	98.1 MHz 65 dBf (60 dB) Ext. modulation	L+R 1 kHz	98.1 MHz	Distortion analyzer	T2	Minimum	
	2	Fig. 2	98.1 MHz 17.2 dBf (12 dB) 1 kHz, 75 kHz devi. 98.1 MHz 16.2 dBf (11 dB) 1 kHz, 75 kHz devi.	—	98.1 MHz	Oscilloscope	R116	Signal output No output	Muting switch to ON.

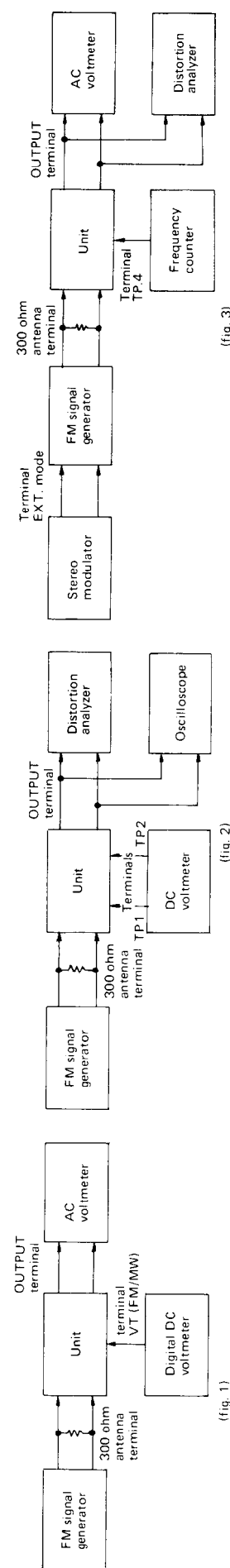

AM section

Step	AM SG output	Tuned frequency	Output indicator	Adjustment point	Adjust for	Remarks
1	999kHz (1000kHz) 400Hz 30% mod.	999kHz (1000kHz)	AC voltmeter	X151 L153	Maximum	
2		522kHz (520kHz)	Digital DC voltmeter	L152	1.2V	Repeat the steps 2 and 3 until no further adjustment is necessary.
3		1611kHz (1710kHz)	Digital DC voltmeter	C157	9.5V (10.5V)	
4	603kHz (600kHz) 400Hz 30% mod.	603kHz (600kHz)	AC voltmeter	L151	Maximum	Repeat the steps 4 and 5 until no further adjustment is necessary.
5	1404kHz (1404kHz) 400Hz 30% mod.	1404kHz (1400kHz)	AC voltmeter	C151	Maximum	

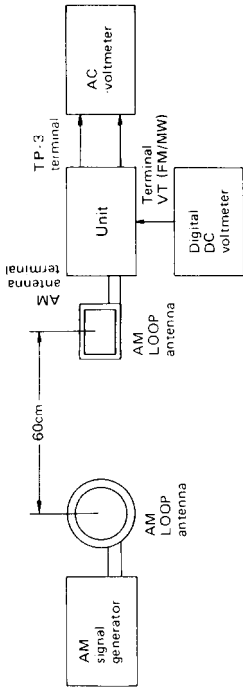

() : 120V model

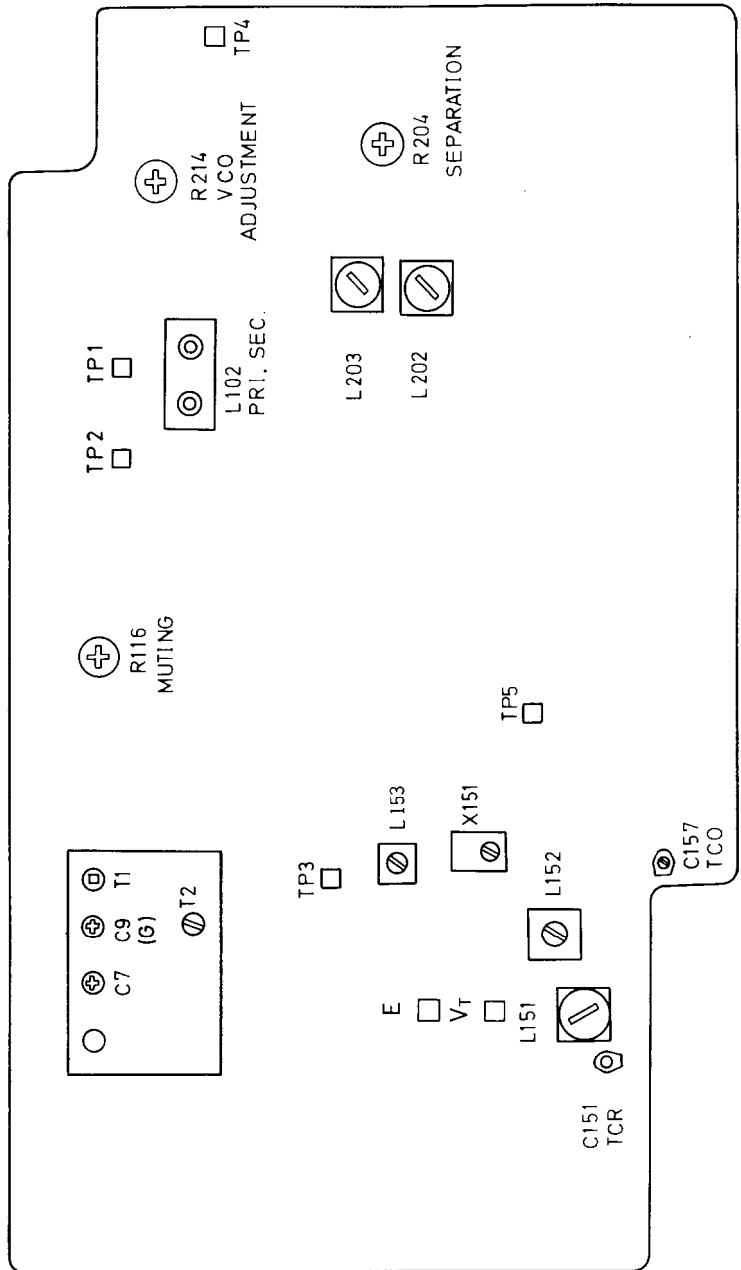

SCHEMATIC DIAGRAM

-G/Q MODELS-

NOTES

- * ALL RESISTORS ARE IN OHMS UNLESS OTHERWISE NOTED.
- * ALL CAPACITORS ARE IN μ F UNLESS OTHERWISE NOTED.
- * ELECTROLYTIC CAPACITORS μ F ARE IN μ F/VV.
- * VOLTAGE MEASUREMENTS WITH V.T.M. AND INPUT SIGNAL.
- * CIRCUIT IS SUBJECT TO CHANGE FOR IMPROVEMENT.

THE COMPONENTS IDENTIFIED BY MARK Δ ARE CRITICAL FOR SAFETY.

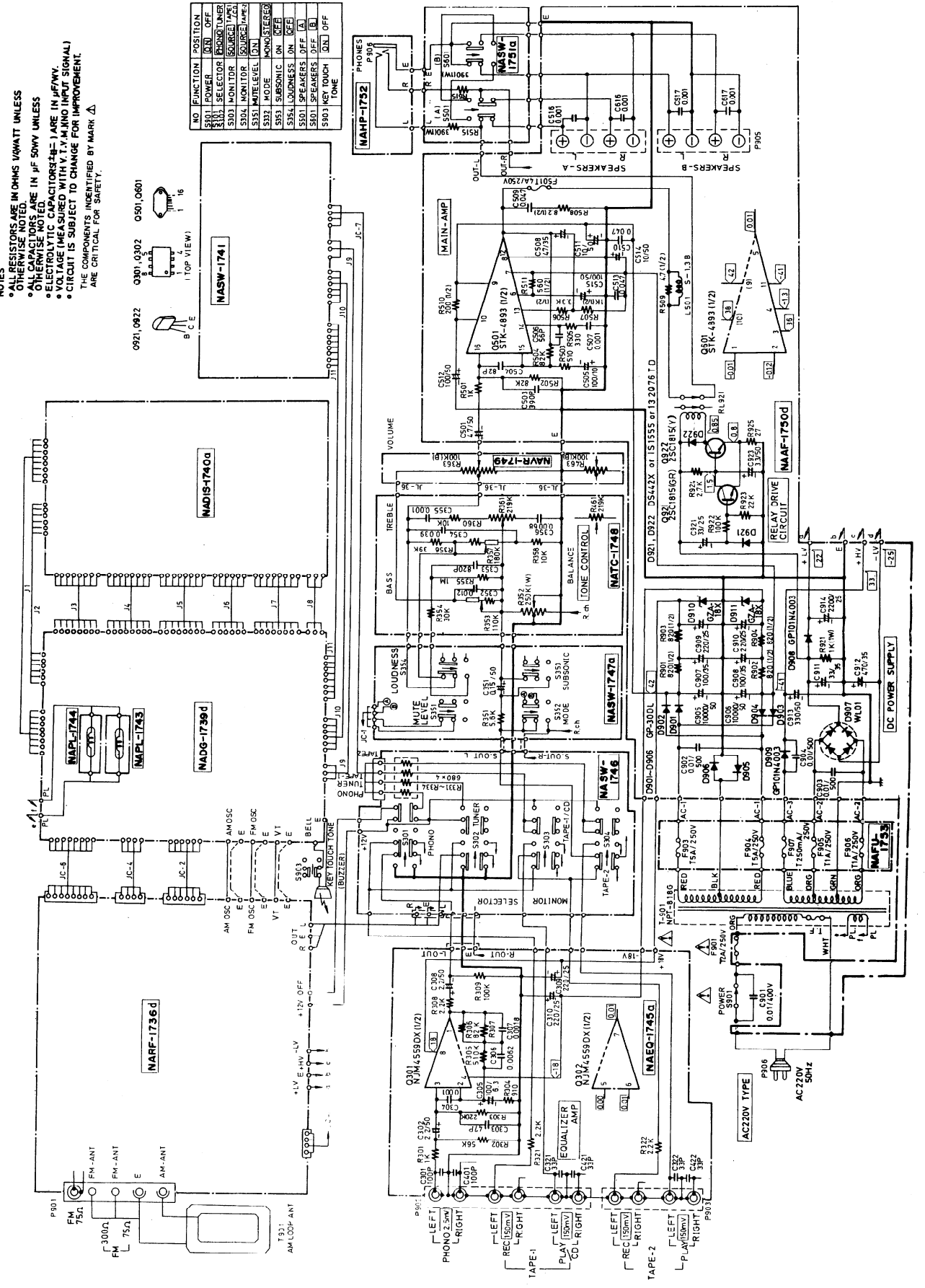

SCHEMATIC DIAGRAM

- D/W MODELS -

- NOTES**
- ALL RESISTORS ARE IN OHMS UNLESS OTHERWISE NOTED.
 - ALL CAPACITORS ARE IN μ F UNLESS OTHERWISE NOTED.
 - ELECTROLYTIC CAPACITORS ARE IN μ FVW.
 - VOLTAGE (MEASURED WITH 1 K Ω INPUT SIGNAL) CIRCUIT IS SUBJECT TO CHANGE FOR IMPROVEMENT.
 - THE COMPONENTS IDENTIFIED BY MARK Δ ARE CRITICAL FOR SAFETY.

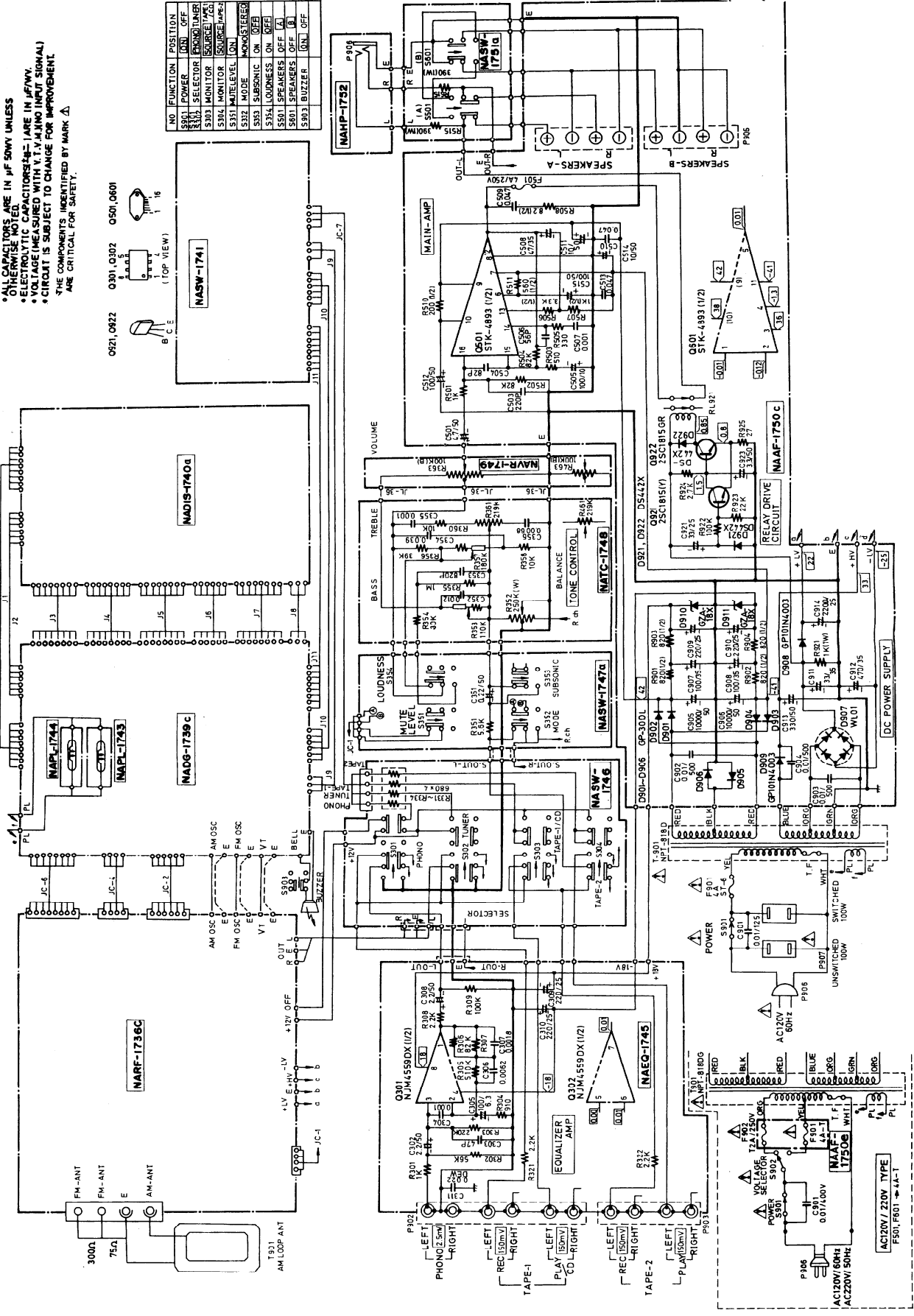

NO	FUNCTION	POSITION
S801	POWER	ON OFF
S802	SELECTOR	PHONO TUNER
S803	MONITOR	SOURCE TUNER
S804	MONITOR	SOURCE TUNER
S805	MUTE LEVEL	ON
S806	MODE	MONOSTEREO
S807	SUBSONIC	ON OFF
S808	LOUDNESS	ON OFF
S809	SPEAKERS	OFF A
S810	SPEAKERS	OFF B
S803	BUZZER	ON OFF

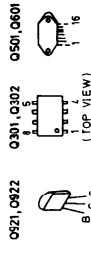

PCB PARTS LIST / VIEW FROM COMPONENT SIDE

FM/AM TUNER PCB VIEW

1

2

3

4

FM/AM TUNER PC BOARD ASS'Y (NARF-1736c/d/e)

CIRCUIT NO.	PARTS NO.	DESCRIPTION	CIRCUIT NO.	PARTS NO.	DESCRIPTION
	Front end			Transistors	
	240061	FE349U14 (D/W)	Q204, Q205	2211705	2SD655 (E)
	240059	FE416U33 (G/Q)	Q805, Q806	2211255	2SC1815 (GR)
	ICs		Q951, Q953	2211255	2SC1815 (GR)
Q103	222608	μ PC1167C2, FM IF system		Diodes	
Q152	222629	μ PC1243C, AM radio system	D001	2239552	RD8. 2EB2 (G/Q)
Q201	222678	μ PC1161C3, Stereo decoder	D102	223105,	1S1555,
Q203	222575 or	TC4066BP or	D201-D203	223133 or	DS442X or
	222840661	4066B, Analogue switch	D141, D142	223145	1S2076TD
Q952	222780122	78M12, Constant voltage	D103, D153	4000068	VD1222
	Transistors		D151, D152	223140	KV1236
Q101	2211723	2SC1923 (O)	D801-D805	223105,	1S1555
Q102	2211723	2SC1923 (O) (G/Q)	D808-D812	223133 or	DS442X or
Q151, Q202	2211945 or	2SK246 (GR) or	D814, D817	223145	1S2076TD
	2212304	2SK381 (D)	D815, D816	2241291	RD3. 3EB1
Q153-Q155	2211254,	2SC1815 (Y),	D951	2239792	RD27EB2
Q801-Q803	2211255 or	2SC1815 (GR) or	D952	2239433	RD4. 7EB3
Q807-Q809	2210746	2SC945A (P)	D953	2239493	RD6. 2EB3
Q141-Q144					

5

CIRCUIT NO.	PARTS NO.	DESCRIPTION
	Transformers	
L001	233026A	NBLN-1, Balloon (G/Q)
L102	233270	NFIF-6040
L153	232095	NMIF-6025
	Coils	
L101	233105 or 233024	NCH-1005 or NCCH-1501
L151	232113	NMA-3049
L152	232084	NMO-2018
L201	233236	NMC-6027 (G/Q)
L202, L203	233291	NMC-5039
L801	233122	NCH-3013
L802	233031	NMC-9-1
	Cermic filters	
X101, X102	3010071	SFE10. 7MA5 (D/W)
X101-X103	3010043	SFE10. 7MM (G/Q)
X151	3010075	SFL450B3
	Capacitors	
C108, C110	352780109	1 μ F, 50V, Elect.
C111	352784799	0.47 μ F, 50V, Elect.
C117	352741009	10 μ F, 16V, Elect.
C151, C157	3060010	NTC20P09, Trimmer
C155	370135114	510pF \pm 5%, 100V, APS
C163	352741019	100 μ F, 16V, Elect.
C167	352750479	4.7 μ F, 25V, Elect.
C168, C142	352780339	3.3 μ F, 50V, Elect.
C169	352741009	10 μ F, 16V, Elect.
C174	352784799	0.47 μ F, 50V, Elect.
C202	352750479	4.7 μ F, 25V, Elect.
C208	352744719	470 μ F, 16V, Elect.
C209, C210	352741009	10 μ F, 16V, Elect.
C213	370134714	470pF \pm 5%, 100V, APS
C214	352780109	1 μ F, 50V, Elect.
C215	352780339	3.3 μ F, 50V, Elect.
C216	352782299	0.22 μ F, 50V, Elect.
C218, C219	352780109	1 μ F, 50V, Elect.
C220	352724719	470 μ F, 6.3V, Elect.
C802	352780229	2.2 μ F, 50V, Elect.
C806	352783399	0.33 μ F, 50V, Elect.
C809	352780229	2.2 μ F, 50V, Elect.
C951	352780109	1 μ F, 50V, Elect.
C954	352751019	100 μ F, 25V, Elect.
C956	352724719	470 μ F, 6.3V, Elect.
C958	352780109	1 μ F, 50V, Elect.
C970	352751029	1,000 μ F, 25V, Elect.
	Resistors	
R116	5215046	N08HR50KBC, Semi-fixed
R204	5215048	N08HR200KBC, Semi-fixed
R214	5215044	N08HR5KBC, Semi-fixed
R952	441721204	12ohm, 2W, Metal oxide film
R955	441523904	39ohm, 1/2W, Metal oxide film
	Terminal	
P901	25060082	NTM-4PDMN26, Antenna (D/W)
	25060083	NTM-5PDMN27, Antenna (G/Q)
	Switch	
S001	25035407	NPS-122-L371, Antenna attenuator (G/Q)

Note: (D): Only 120V model
(G): Only 220V model
(W): Only 120/220V model
(G): Only 240V model

SCHEMATIC DIAGRAM

-120/220V MODEL-

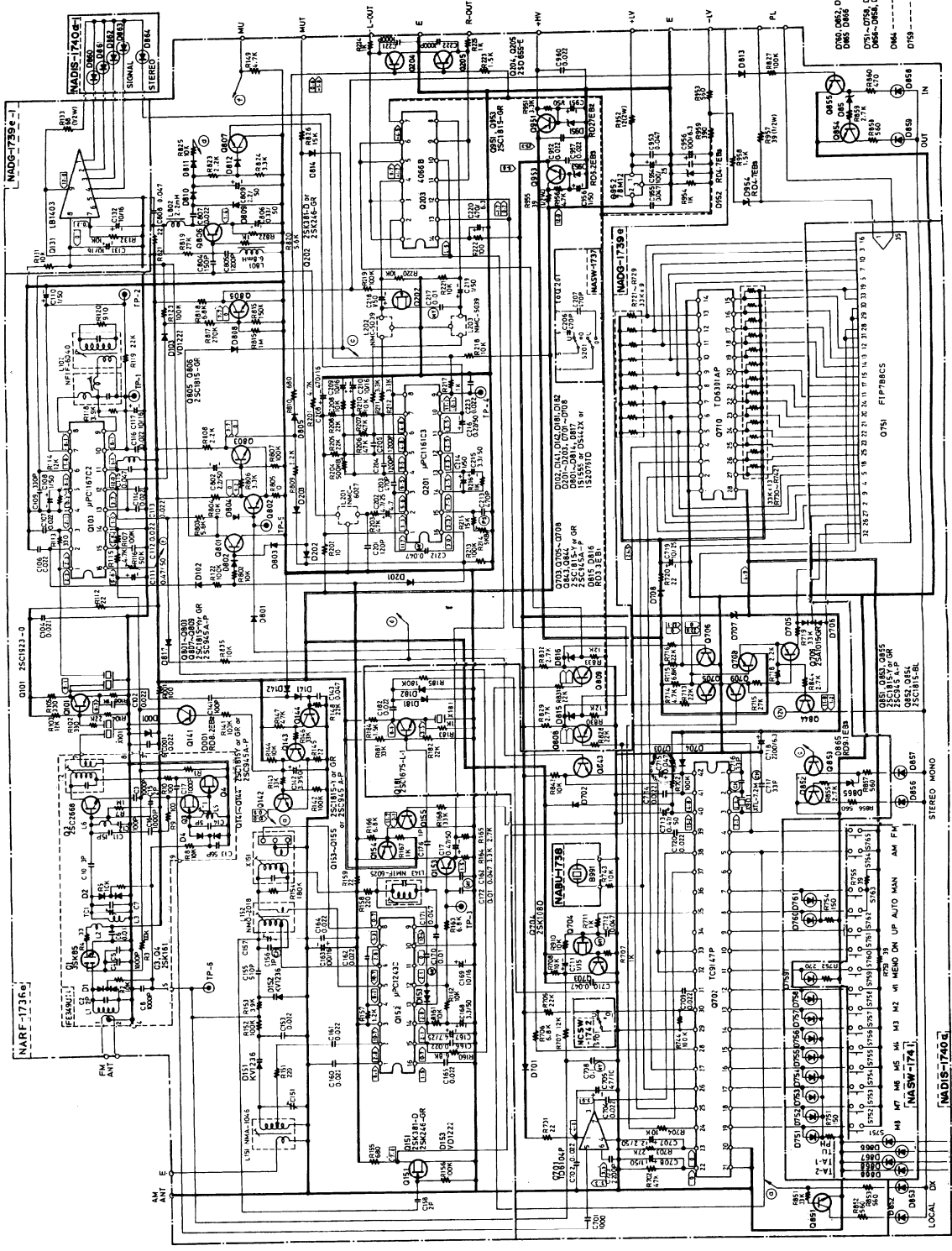

- NOTES**
- ALL RESISTORS ARE IN OHMS /AWATT UNLESS OTHERWISE NOTED.
 - ALL CAPACITORS ARE IN P.F. 50V UNLESS OTHERWISE NOTED.
 - ELECTROLYTIC CAPACITORS (-E-) (NO INPUT SIGNAL)
 - VOLTAGE IS ASSUMED WITH V.T.V. (NO INPUT SIGNAL)
 - CIRCUIT IS SUBJECT TO CHANGE FOR IMPROVEMENT.

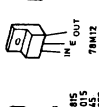
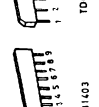
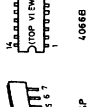
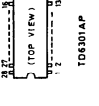
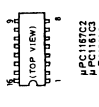
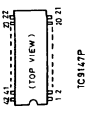
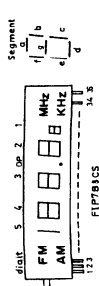

PCB PARTS LIST/VIEW FROM COMPONENT SIDE

DIGITAL CIRCUIT PCB VIEW

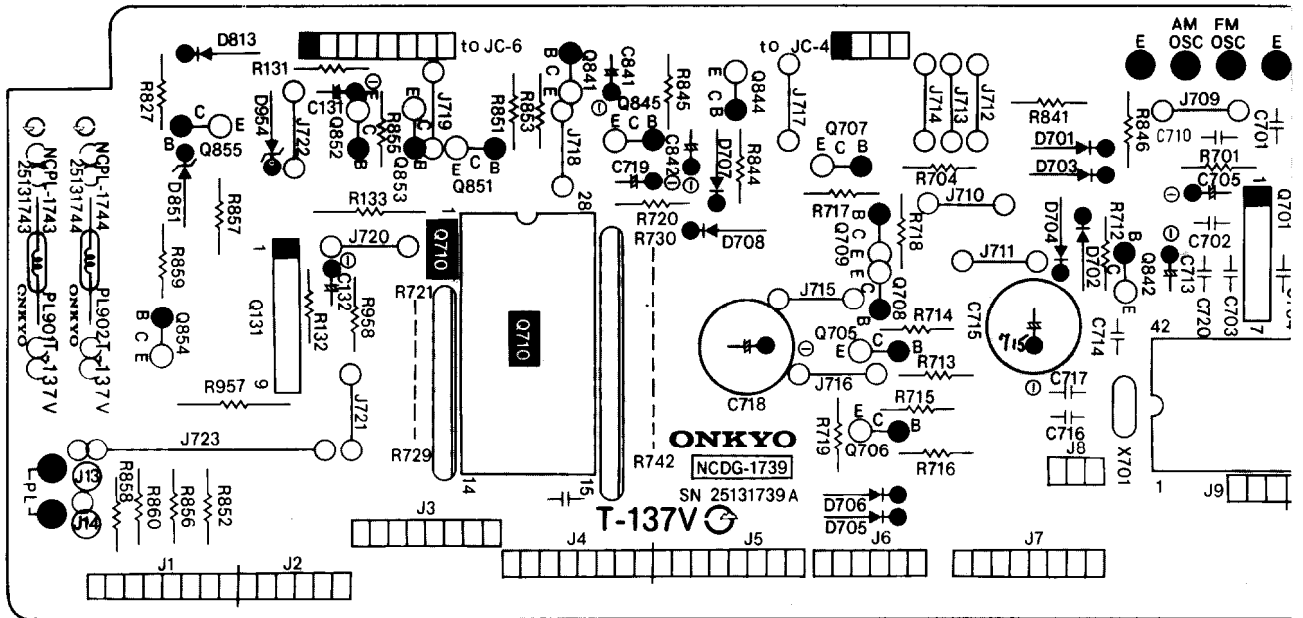

TUNER SWITCH PC BOARD ASS'Y (NASW-1741)

CIRCUIT NO.	PARTS NO.	DESCRIPTION
LEDs		
D759	225126	GL3PR1
D865, D866	225137	SEL2413E
D867, D868	225142	SEL2913K
Switches		
S751-S765	25035275	NPS-111-S239
Spacer		
	27270103	
 HOLDERS		
	27190224	LED

DE-EMPHASIS SWITCH PC BOARD ASS'Y (NASW-1737) (Only W model)

CIRCUIT NO.	PARTS NO.	DESCRIPTION
S201	250142	NSS-2225, De-emphasis switch

BAND SELECTOR SWITCH PC BOARD ASS'Y (NASW-1742) (Only W model)

CIRCUIT NO.	PARTS NO.	DESCRIPTION
S701	250142	NSS-2225, Switch

DIAL PLATE ILLUMINATION LAMP PC BOARD ASS'Y (NAPL-1743/1744)

CIRCUIT NO.	PARTS NO.	DESCRIPTION
PL901	210162	PL6. 3V0. 25A, Lamp

FLUORESCENT INDICATOR TUBE PCB VIEW

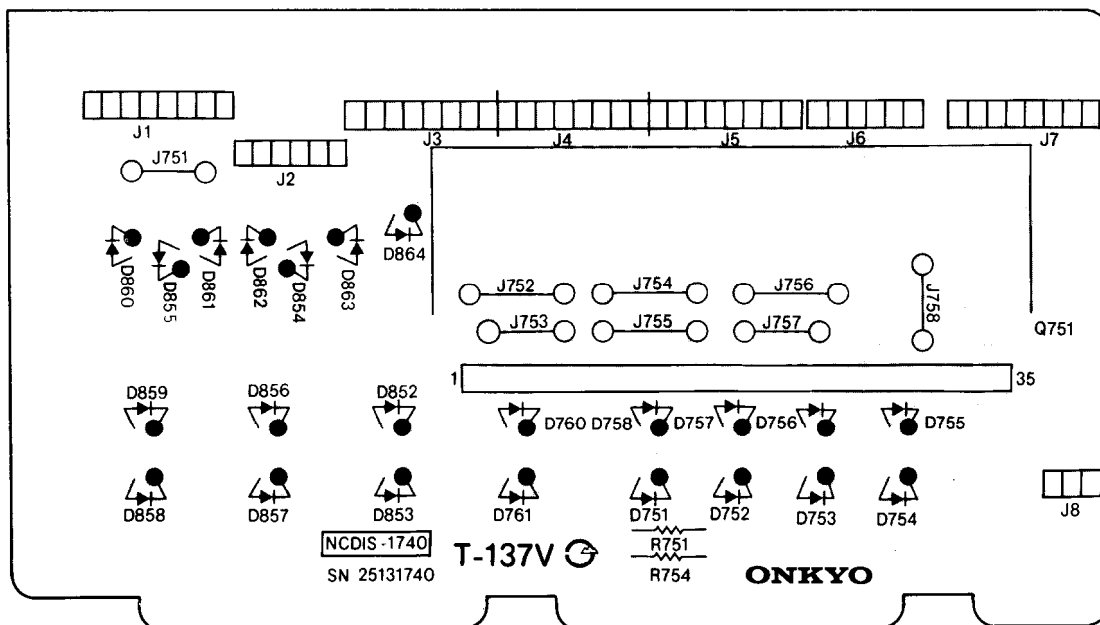

TUNER

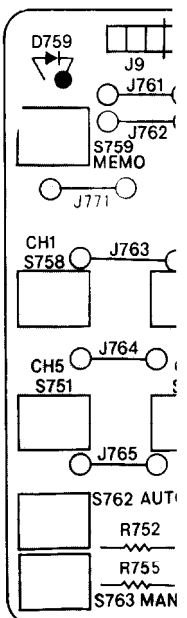

Notes: (D): Only 120V model
 (G): Only 220V model
 (W): Only 120/220V model
 (Q): Only 240V model

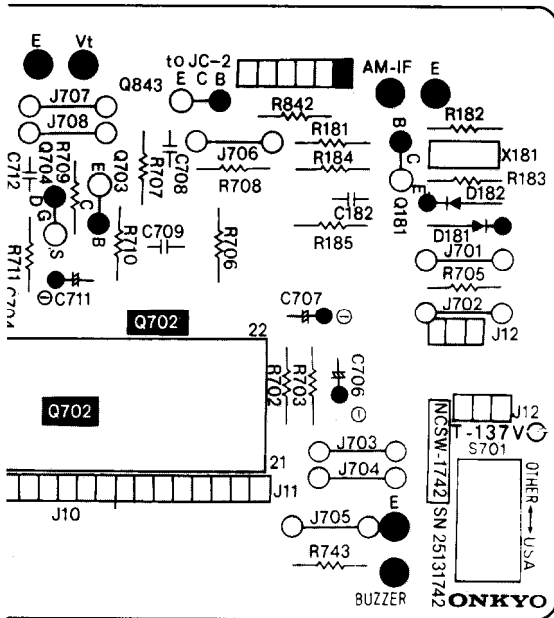

BUZZER PC BOARD PARTS LIST

CIRCUIT NO.	PARTS NO.	DESCRIPTION
	241048	PKM24-4A0, Buzzer

**DIGITAL CIRCUIT PC BOARD ASS'Y
 (NADG-1739/c/d/e)**

CIRCUIT NO.	PARTS NO.	DESCRIPTION
ICs		
Q701	222675	TD6104P, Prescaler
Q702	222674	TC9147P, PLL synthesizer/ controller
Q710	222673	TD6301AP, Static frequency indicator driver
Q131	222666	LB1403
Transistors		
Q703	2211255	2SC1815 (GR)
Q704	2212294	2SK108 (D)
Q705, Q706	2211254,	2SC1815 (Y),
Q844, Q843	2211255 or	2SC1815 (GR) or
Q851, Q853,	2210746	2SC945 A (P)
Q855		
Q852, Q854	2211256	2SC1815 (BL)
Q707, Q708	2211255	2SC1815 (GR) (G/Q/W)
Q709	2211455	2SA1015 (GR) (G/Q/W)
Q181	2210823	2SC1675 (L-1)
Diodes		
D181, D182	223105,	1S1555.
D701-D704	223133 or	DS442X or
D707, D708	223145	1S2076TD
D813		
D705, D706	223105,	1S1555,
	223133 or	DS442X or
	223145	1S2076TD (G/Q/W)
D851, D865	224178,	05Z9. 1Y.
	2241052 or	GZA9. 1EB3 or
	2239573	RD9. 1EB3
D954	2239433	RD4. 7EB3
Ceramic filter		
X181	3010076	BFU450C
X'tal		
X701	3010073	XTL-7.2M
Capacitors		
C705	352734709	47µF, 10V, Elect.
C706	352780109	1µF, 50V, Elect.
C707	352780229	2.2µF, 50V, Elect.
C711	395160107	1µF, 35V, Tantalum
C713	352784799	0.47µF, 50V, Elect.
C715	3020018	0.047F, 5V, Super
C718	352722229	2,200µF, 6.3V, Elect.
C719	352751009	10µF, 25V, Elect.
C841	352780339	3.3µF, 50V, Elect.
C131, C132	352740109	10µF, 16V, Elect.
Resistors		
R721-R729	49121333509	33kohm×9, 1/8W, Network
R730-R742	49121333513	33kohm×13, 1/8W, Network
R957	441523904	39ohm, 1/2W, Metal oxide film
R133	441526804	68ohm, 1/2W, Metal oxide film

**FLUORESCENT INDICATOR TUBE PC BOARD ASS'Y
 (NADIS-1740a)**

CIRCUIT NO.	PARTS NO.	DESCRIPTION
Fluorescent indicator tube		
Q751	212016	FIP7B8CS
LEDs		
D751-D758	225142	SEL2913K
D761, D853		
D760, D852	225137	SEL2413E
D859-D863		
D856-D858	225142	SEL2913K
D864	225141	SEL2213C
Holders		
	27190222	LED16
	27190230	LED5
Cushion		
	28140513	40×10×8mm

SWITCH PCB VIEW

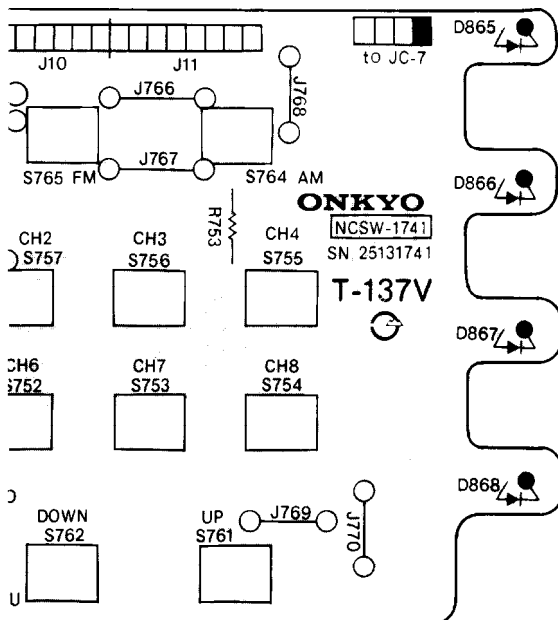

PCB PARTS LIST/VIEW FROM COMPONENT SIDE

POWER SUPPLY AND AMPLIFIER PCB VIEW

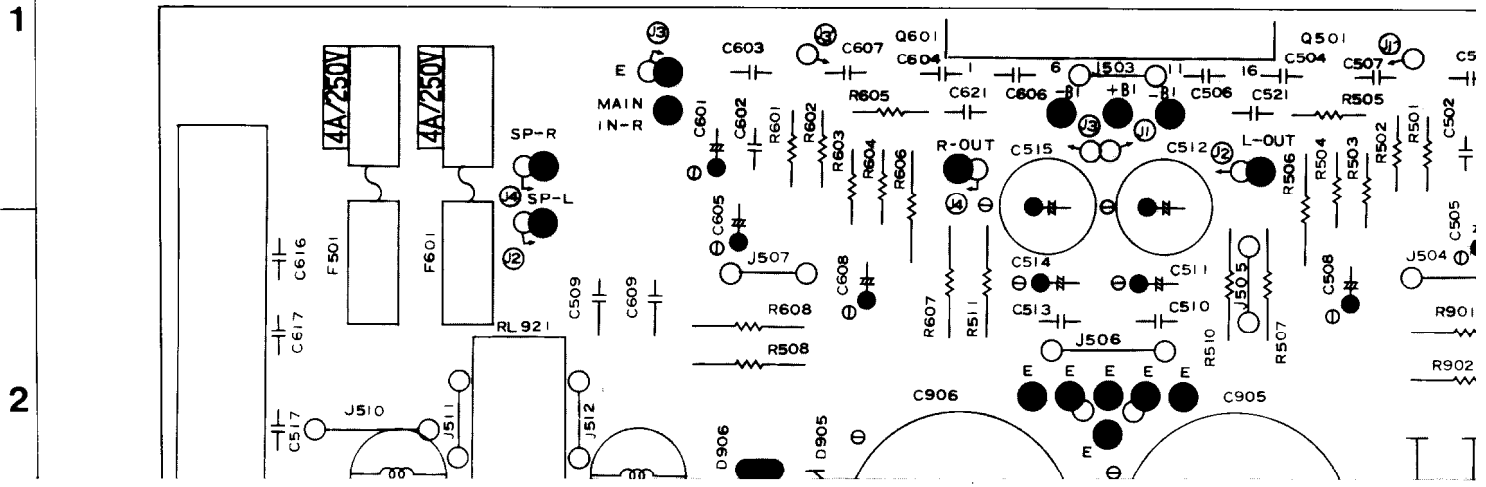

MODEL TX-35

SUBSTITUTIVE PARTS LIST

NOTE: USE THE REGULAR PARTS WHEN REPLACEMENT

TYPE	CIRCUIT NO.	DESCRIPTION	REGULAR PARTS	SUBSTITUTIVE PARTS	APPLICATION
UG	D760, 852, 859-863	LED	SEL2413E	SEL2310G	2936-3135
UG	D865, D866	LED	SEL2413E	SEL2310G	2936-3135
UD	D910, D911	DIODE	GZA-18X OR Y	EQAD2-17A	5016-10415
UG	Q301	IC	NJM4559DX	NJM4560DX	3136-3335
UD	D953	DIODE	RD6.2EB3	GZA6.2Y	11016-12015
UD	D760, 852, 859-863	LED	SEL2413E	SEL2310G	12016-14015
UD	D865, D866	LED	SEL2413E	SEL2310G	12016-14015
UD	D953	DIODE	RD6.2EB3	MTZ6.2C	12016-14015
UD	D865	DIODE	RD9.1EB3	MTZ9.1C	14016-15815
UD	Q201	IC	MPC1161C3	MPC1161C	14016-15815
UD	Q103	IC	MPC1167C2	MPC1267C	15816-18215
UD	Q301	IC	NJM4559DX	NJM4559DD	15816-18215
UD	D953	DIODE	RD6.2EB3	EQAD2-D6E	17016-18215

MODEL TX-35

SUBSTITUTIVE PARTS LIST

NOTE: USE THE REGULAR PARTS WHEN REPLACEMENT

TYPE	CIRCUIT NO.	DESCRIPTION	REGULAR PARTS	SUBSTITUTIVE PARTS	APPLICATION
UG	D760, 852, 859-863	LED	SEL2413E	SEL2310G	2936-3135
UG	D856, D866	LED	SEL2413E	SEL2310G	2936-3135
UD	D910, D911	DIODE	GZA-18X OR Y	EQAD2-17A	5016-10415
UG	Q301	IC	NJM4559DX	NJM4560DX	3136-3335
UD	D953	DIODE	RD6.2EB3	GZA6.2Y	11016-12015

PCB PARTS LIST/VIEW FROM COMPONENT SIDE

POWER SUPPLY AND AMPLIFIER PCB VIEW

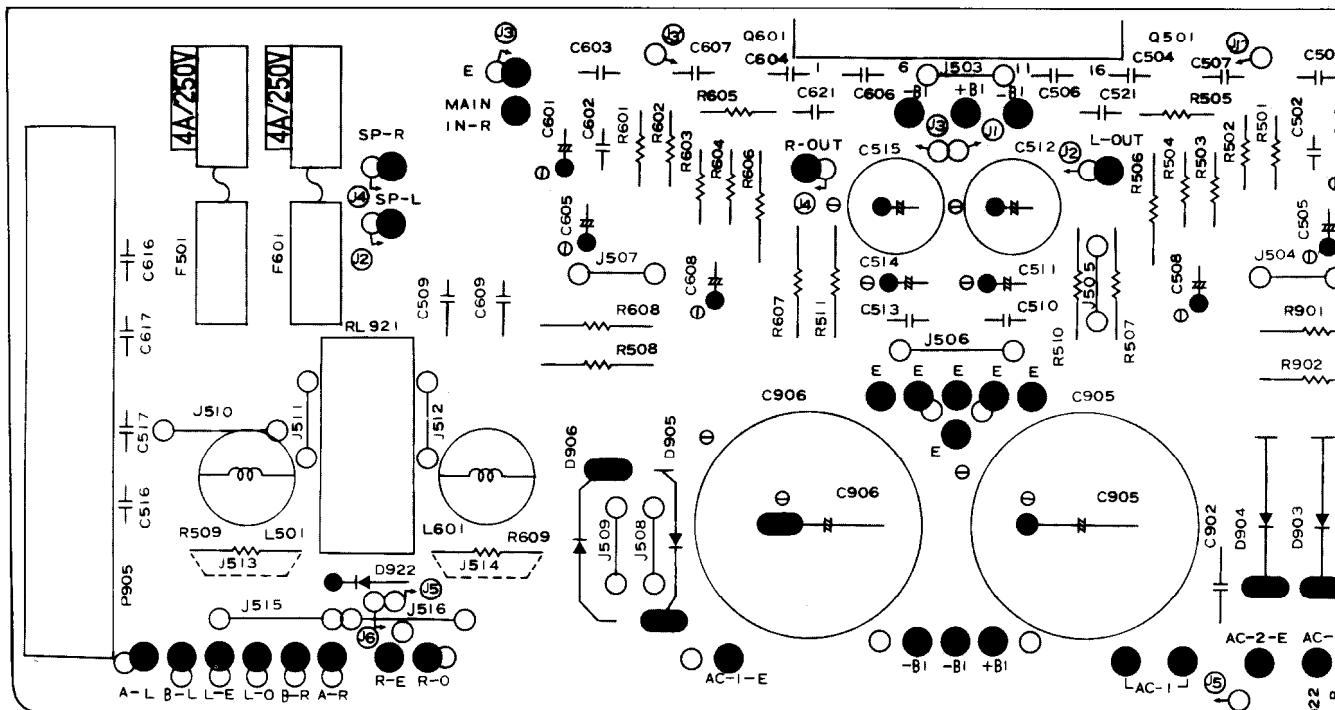

SPEAKER SELECTOR

SWITCH PCB VIEW

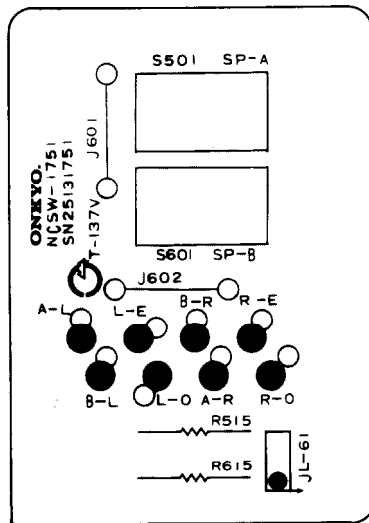

FUSE PCB VIEW

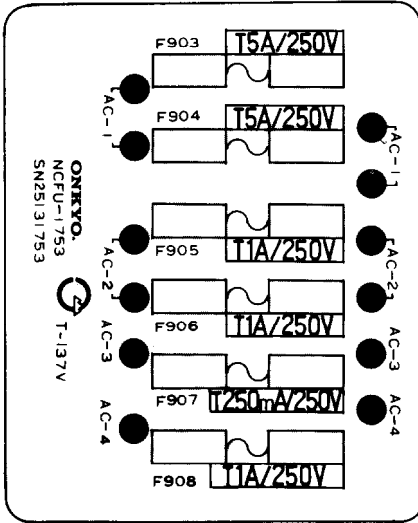

SPEAKER SELECTOR SWITCH PC BOARD ASS'Y (NASW-1751a)

CIRCUIT NO.	PARTS NO.	DESCRIPTION
	Resistors	
R515, R615	441523914	390ohm, 1/2W, Metal oxide film
	Switches	
S501, S601	25035397	NPS-222-L361

HEADPHONE TERMINAL PC BOARD ASS'Y (NAHP-1752)

CIRCUIT NO.	PARTS NO.	DESCRIPTION
P906	25045138	HLJ0520-01-010

FUSE TERMINAL PC BOARD ASS'Y (NAFU-1753)

CIRCUIT NO.	PARTS NO.	DESCRIPTION
	Fuseholders	
	25050065	YSH403T
	Fuses	
△ F903, F904	252078	5A-SE-EAK
△ F905, F906	252070	1A-SE-EAK
△ F907	252088	0.25A-SE-EAWK
		(Only 220/240V models)

Note: (D): Only 120V model
 (G): Only 220V model
 (W): Only 120/220V model
 (Q): Only 240V model

**POWER SUPPLY AND POWER AMPLIFIER CIRCUIT
 PC BOARD ASS'Y (NAAF-1750c/d/e)**

CIRCUIT NO.	PARTS NO.	DESCRIPTION
	IC	
Q501, Q601	222036	STK-4893, Power amplifier
	Transistors	
Q921	2211255	2SC1815 (GR)
Q922	2211254	2SC1815 (Y)
	Diodes	
D901-D906	223863	GP30DL
D907	223862	WL-01
D908, D909	223880	GP101N4003
D910, D911	2241191 or 2241192	GZA-18X or GZA-18Y
D921, D922	223145, 223133 or 223105	1S2076TD, DS442X or 1S1555
	Coils	
L501, L601	231001	S1. 3B (G/Q)
	Capacitors	
C501, C601	352780479	4.7 μ F, 50V, Elect.
C505, C605	352731019	100 μ F, 10V, Elect.
C508, C608	352764709	47 μ F, 35V, Elect.
C511, C514	352781009	10 μ F, 50V, Elect.
C512, C515	352781019	100 μ F, 50V, Elect.
C905, C906	3504178	10.000 μ F, 50V, Elect.
C907, C908	352761019	100 μ F, 35V, Elect.
C909, C910	352752219	220 μ F, 25V, Elect.
C911	352763309	33 μ F, 35V, Elect.
C912	352764719	470 μ F, 35V, Elect.
C913	352783319	330 μ F, 50V, Elect.
C914	352752229	2.200 μ F, 25V, Elect.
C921	352753309	33 μ F, 25V, Elect.
C923	352780339	3.3 μ F, 50V, Elect.
	Resistors	
R506, R606	441523324	3.3kohm, 1/2W, Metal oxide film
R507, R607	441521024	1kohm, 1/2W, Metal oxide film
R508, R608	441520824	8.2ohm, 1/2W, Metal oxide film
R509, R609	441520474	4.7ohm, 1/2W, Metal oxide film (G/Q)
R510	441522014	200ohm, 1/2W, Metal oxide film
R511	441525614	560ohm, 1/2W, Metal oxide film
R901-R904	441528214	820ohm, 1/2W, Metal oxide film
△ R905	431523355	3.3Mohm, 1/2W, Solid (D)
R921	441621024	1kohm, 1W, Metal oxide film
	Relay	
RL921	25065134	NRL-2P5A-DC24-07
	Terminal	
P905	25060058	NTM-8PDML25, Speaker
	Fuseholders	
△ F901a, F501a	250113	SNS051 (D/W)
F601a		
F902a	25050065	YSH403T (G/Q/W)
F501a, F601a	25050065	YSH403T (G/Q)
	Fuses	
△ F501, F601	252059	4A (SS-2), Speaker (D)
	252077	4A-SE-EAK, Speaker (G/Q)
	252014	4A-T, Speaker (W)
△ F901	252049	4A (ST-6), Primary (D)
	252014	4A-T, Primary (W)
△ F902	252074	2A-SE-EAK, Primary (G/Q/W)

NOTE: THE COMPONENTS IDENTIFIED BY MARK
 △ ARE CRITICAL FOR RISK OF FIRE AND
 ELECTRIC SHOCK. REPLACE ONLY WITH
 PARTS NUMBER SPECIFIED.

PCB PARTS LIST/VIEW FROM COMPONENT SIDE

EQUALIZER AMPLIFIER PCB VIEW

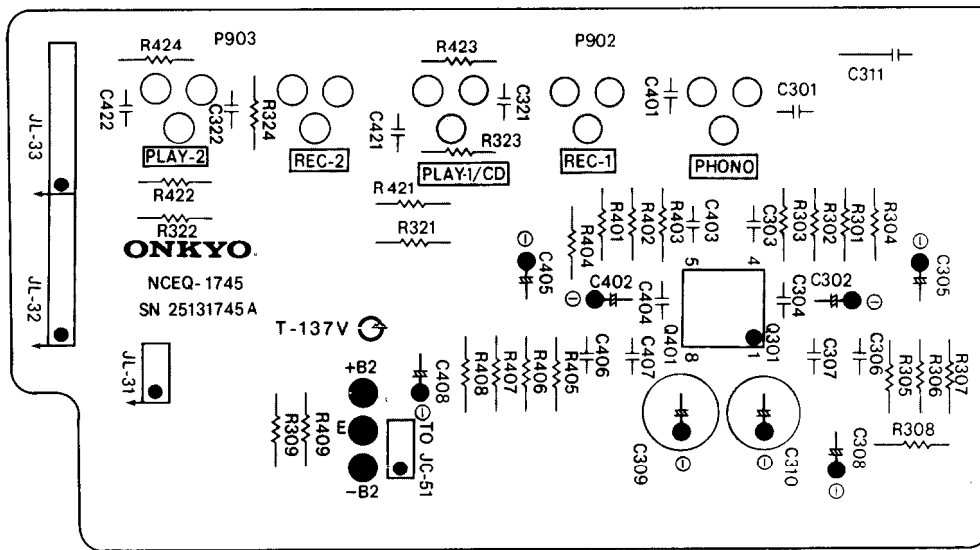

EQUALIZER AMPLIFIER PC BOARD ASS'Y (NAEQ-1745/a)

CIRCUIT NO.	PARTS NO.	DESCRIPTION
IC		
Q301, Q401	222534	NJM-4559DX
Capacitors		
C302, C402	352780229	2.2 μ F, 50V, Elect.
C305, C405	352721019	100 μ F, 6.3V, Elect.
C308, C408	352780229	2.2 μ F, 50V, Elect.
C309, C310	352752219	220 μ F, 25V, Elect.
Terminals		
P902	25045137	NPJ-6PDBL52, Phono/Tape 1
P903	25045084	NPJ-4PDBL42, Tape 2

BLOCK DIAGRAM

STK-4893 (Power amplifier)

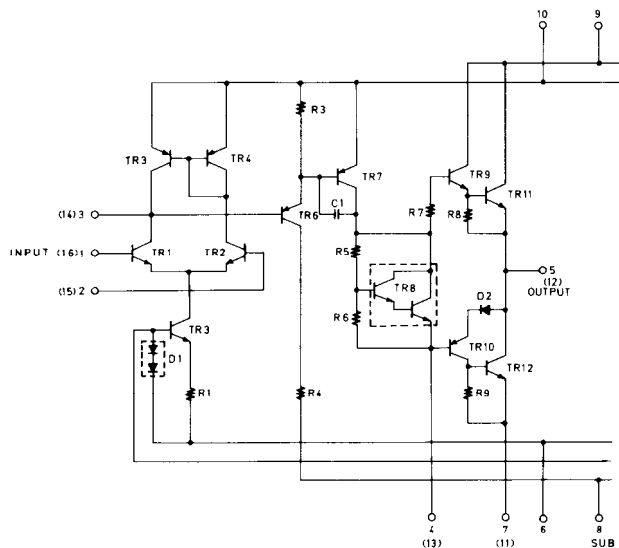

NJM-4559DX (Equalizer amplifier)

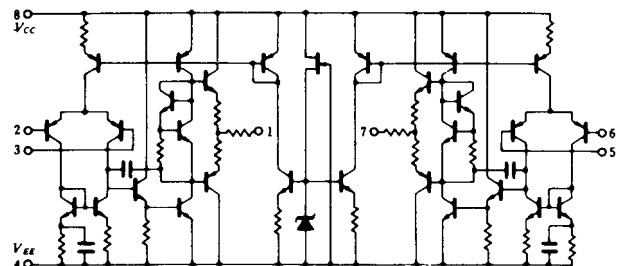

TONE CONTROL PCB VIEW

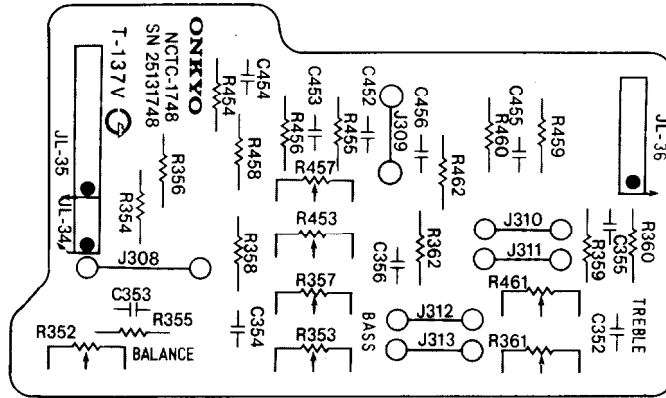

VOLUME CONTROL PCB VIEW

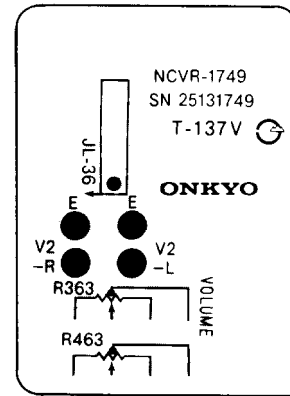

TONE CONTROL CIRCUIT PC BOARD ASS'Y (NATC-1748)

CIRCUIT NO.	PARTS NO.	DESCRIPTION
Variable resistors		
R352	5146034	N16RLC250KWT30, Balance
R353, R453	5148073	N16RQMC110K180K30, Bass
R357, R457		
R361, R461	5148074	N16RGMC219K30, Treble

VOLUME CONTROL PC BOARD ASS'Y (NAVR-1749)

CIRCUIT NO.	PARTS NO.	DESCRIPTION
R363, R463	5148093	N16RGM100KBT35, Variable resistor

SELECTOR SWITCH PCB VIEW

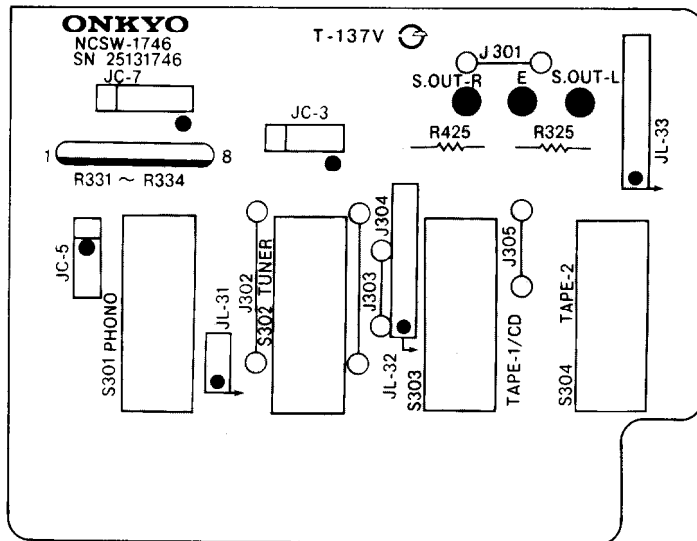

SWITCH PCB VIEW

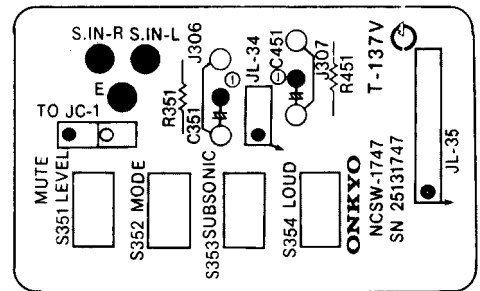

SELECTOR SWITCH PC BOARD ASS'Y (NASW-1746)

CIRCUIT NO.	PARTS NO.	DESCRIPTION
Resistor		
R331-R334	49241681504	680ohm×4, 1/4W, Network
Switches		
S301-S304	25035395	NPS-442-L358, Push

SWITCH PC BOARD ASS'Y (NASW-1747a)

CIRCUIT NO.	PARTS NO.	DESCRIPTION
S351-S354	25035400	NPS-422-L360, Push switch

BLOCK DIAGRAM OF IC

μPC1167C2 (FM IF system)

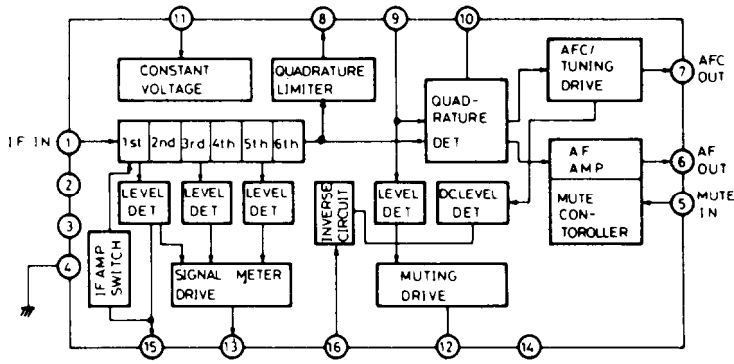

1. IF signal input
2. IF amplifier switch input
H level: Off
5. Muting switch input
6. Composite signal output
7. AFC output
8. IF amplifier output
9. 10.7MHz input
10. Reference voltage
11. Power supply
12. Muting output
Tuned: L level
13. Signal strength output
15. AGC output
16. Muting level

μPC1243C (AM radio system)

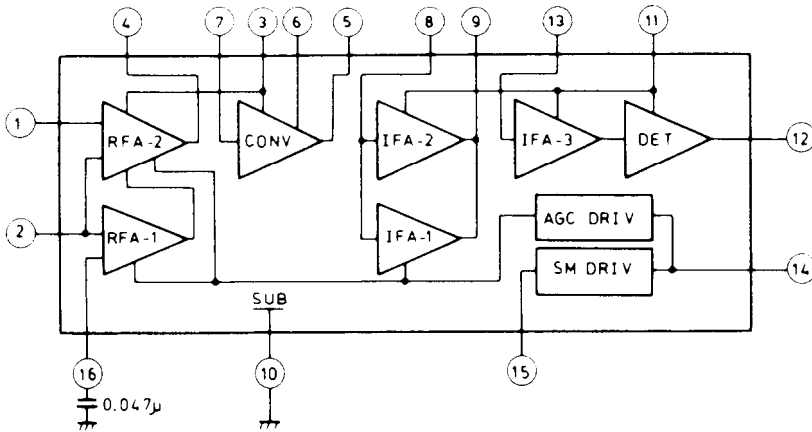

TC4066BP (Analogue switch)

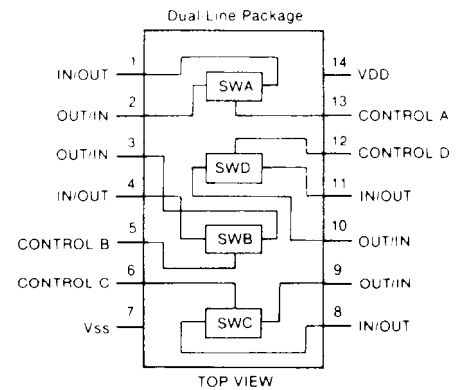

μPC1161C3 (Stereo decoder)

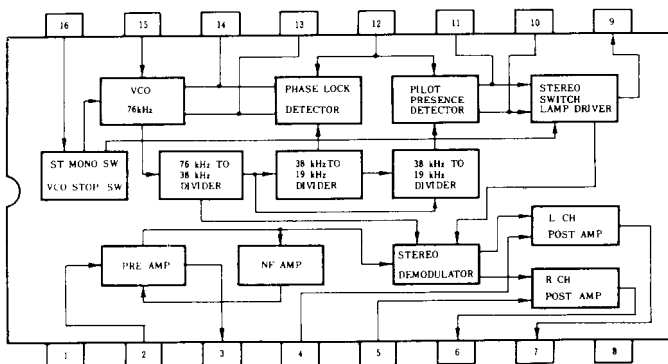

PACKING VIEW

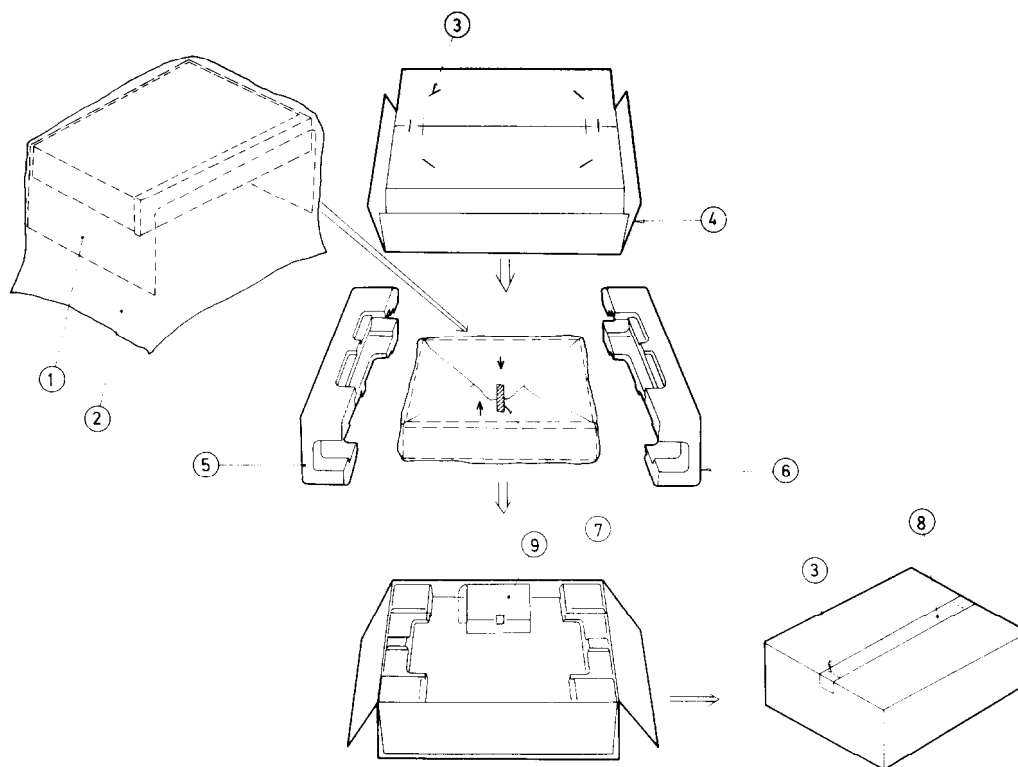

REF. NO.	PARTS NO.	DESCRIPTION	
1	29095012-1	500×800mm, Protection sheet	
2	29100034	650×850mm, Poly-vinyl bag	
3	282301	Sealing hook	
4	29050801	Master carton box	
	29050806	Master carton box (B)	
5	29090817A	Pad R	
6	29090816A	Pad L	
7	29110032	W=15mm, Adhesive tape	
8	260012	50(W)×600mm, Damplon tape	
9		Accessory bag complete	
	U.S.A. model		
	292064A	FM antenna	
	29100006	350×250mm, Poly-vinyl bag	
	29340710	Instruction manual	
	29365006-5	Warranty card	
	29358002A	Service station list	
	120V model		
	292064A	FM antenna	
	29100006	350×250mm, Poly-vinyl bag	
	29340710	Instruction manual	
	29365005-3A	Warranty card	
	29358004	Service station list	
	220V model		
	292064A	FM antenna	
	29100006	350×250mm, Poly-vinyl bag	
	29340711	Instruction manual	
	292064A	FM antenna	
	29100006	350×250mm, Poly-vinyl bag	
	29340711	Instruction manual	
	25055040	CV-K-2, Conversion plug	
	29340710	Instruction manual	
	West Germany model		
	292064A	FM antenna	
	29100006	350×250mm, Poly-vinyl bag	
	29340711	Instruction manual	
	29365005-3A	Warranty card	
	29358004	Service station list	
	120/220V model		
	292064A	FM antenna	
	29100006	350×250mm, Poly-vinyl bag	
	29340711	Instruction manual	
	25055040	CV-K-2, Conversion plug	

Note: (B): Only black model

ONKYO CORPORATION

International Division: No. 24 Mori Bldg., 23-5, 3-chome, Nishi-Shinbashi, Minato-ku, Tokyo, Japan
Telex: 2423551 ONKYO J. Phone: 03-432-6981

ONKYO U.S.A. CORPORATION

200 Williams Drive, Ramsey, N.J. 07446 Tel. 201-825-7950

ONKYO DEUTSCHLAND GMBH, ELECTRONICS

8034 München-Germering, Industriestrasse 18, West Germany. Telex: 521726 Telefon: (089)-84-3071