

ONKYO SERVICE MANUAL

QUARTZ SYNTHESIZED TUNER AMPLIFIER MODEL TX-37



Silver and black models

UD, UDN, BUD, BUDN	120V AC, 60Hz
UG, BUG	220V AC, 50Hz

SAFETY-RELATED COMPONENT WARNING!!

COMPONENTS IDENTIFIED BY MARK \triangle ON THE SCHEMATIC DIAGRAM AND IN THE PARTS LIST ARE CRITICAL FOR RISK OF FIRE AND ELECTRIC SHOCK. REPLACE THESE COMPONENTS WITH ONKYO PARTS WHOSE PARTS NUMBERS APPEAR AS SHOWN IN THIS MANUAL.

MAKE LEAKAGE-CURRENT OR RESISTANCE MEASUREMENTS TO DETERMINE THAT EXPOSED PARTS ARE ACCEPTABLY INSULATED FROM THE SUPPLY CIRCUIT BEFORE RETURNING THE APPLIANCE TO THE CUSTOMER.

TABLE OF CONTENTS

Specifications	2
Service procedures	3
Block diagram	
Amplifier section	4
Power supply section	5
Dynamic bass circuit	5
Tuner section -120V-	6
Tuner section -220V-	7
Exploded view	8
Parts list	9
Circuit description	10
Adjustment procedures	15
Pcb view/list	
Tuner section	17
Digital section	21
Amplifier section	25
Control section	29
Schematic diagram	
Tuner section 120V model	19
Tuner section 220V model	23
Amp. section 120V model	27
Amp. section 220V model	31
Block diagram of IC	33
Packing view	34

ONKYO
AUDIO COMPONENTS

SPECIFICATIONS

AMPLIFIER SECTION

Power Output:	55 watts per channel, min RMS, at 8 ohms, both channels driven, from 20Hz to 20kHz, with no more than 0.04% THD.
Musical Power Output:	2 × 120 watts at 4 ohms, 1kHz (DIN) 2 × 77 watts at 8 ohms, 1kHz (DIN)
Continuous Power Output:	2 × 77 watts at 4 ohms, 1kHz (DIN) 2 × 55 watts at 8 ohms, 1kHz (DIN)
Total Harmonic Distortion:	0.04% at rated power 0.04% at 1 watt output
IM Distortion:	0.04% at rated power 0.04% at 1 watt output
Damping Factor:	35 at 8 ohms
Frequency Response:	20 – 30,000 Hz ± 1 dB
RIAA Deviation:	20 – 20,000 Hz ± 0.8dB
Sensitivity and Impedance:	Phono: 2.5mV/50 kohms CD/Tape Play: 150mV/50 kohms Tape Rec: 150mV/3.5 kohms (phono)
Phono Overload:	180mV RMS at 1 kHz, 0.04% THD
Signal-to-Noise Ratio:	Phono: 85dB (at 10mV input, A weighted) 76dB (IHF A-202) CD/Tape: 95dB (A weighted) 80dB (IHF A-202)
Tone Controls:	Bass: ± 10dB at 100Hz Treble: ± 10dB at 10kHz
Loudness (–30dB):	+7 dB at 70 Hz, +5 dB at 10kHz
Subsonic:	–6 dB at 15 Hz

TUNER SECTION

FM:

	–G/W MODELS–	–D MODEL–
Tuning Range:	87.5 – 108.0 MHz (50kHz steps)	87.5 – 108.0 MHz (100kHz steps)
Usable Sensitivity:	Mono: 11.2dBf, 1.0μV, 75 ohms 0.9μV (S/N 26dB, 40kHz Devi.) 75 ohms DIN Stereo: 18.0dBf, 2.2μV, 75 ohms 23μV (S/N 46dB, 40kHz Devi.) 75 ohms DIN	Mono: 10.8dBf, 1.9μV Stereo: 17.2dBf, 4.0μV
50dB Quieting Sensitivity:	Mono: 18.0dBf, 2.2μV 75 ohms Stereo: 37.2dBf, 20μV, 75 ohms	Mono: 17.2dBf, 4.0μV Stereo: 37.2dBf, 40μV
Capture Ratio:	1.5dB	1.5dB
Image Rejection Ratio:	85dB	40dB
IF Rejection Ratio:	90dB	90dB
Signal-to-Noise ratio:	Mono: 72dB Stereo: 67dB	Mono: 72dB Stereo: 67dB
Selectivity:	50dB DIN (±300kHz, 40kHz dev.)	55dB
AM Suppression Ratio:	50dB	50dB
Harmonic Distortion:	Mono: 0.15% Stereo: 0.25%	Mono: 0.15% Stereo: 0.25%
Frequency Response:	30 – 15,000Hz ± 1.5dB	30 – 15,000Hz ± 1.5dB
Stereo Separation:	40dB at 1kHz 30dB at 100 – 10,000Hz	40dB at 1kHz 30dB at 100 – 10,000Hz
Tuning Level(Hi/Lo):	23.2dBf, 4μV/17.2dBf, 2μV	23.2dBf, 8μV/17.2dBf, 4μV
Muting Level:	–	–
Stereo Threshold (Hi/Lo):	23.2dBf, 4μV/17.2dBf, 2μV	23.2dBf, 8μV/17.2dBf, 4μV
AM:		
Tuning Range:	522 – 1611kHz (9kHz steps)	520 – 1710kHz (10kHz steps)
Usable Sensitivity:	30μV	30μV
Image Rejection Ratio:	40dB	40dB
IF Rejection Ratio:	40dB	40dB
Signal-to-Noise Ratio:	40dB	40dB
Harmonic Distortion:	0.8%	0.8%

GENERAL

Semiconductors:	FETs: 9 TR: 36 ICs: 12 Diodes: 54 LEDs: 36	FETs: 9 TR: 32 ICs: 12 Diodes: 50 LEDs: 36
Dimensions (W×H×D):	435 × 112 × 343 mm 17-1/8" × 4-7/16" × 13-1/2"	435 × 112 × 343 mm 17-1/8" × 4-7/16" × 13-1/2"
Weight:	8.5 kg 18.8 lbs.	8.5 kg., 18.8 lbs.

Specifications and features are subject to change without notice.

SERVICE PROCEDURES

1. Replacing the fuses

For continued protection against fire hazard, replace only with same type and same rating fuse.

D(120V)model

Circuit no.	Parts no.	Description
F501, F601	252059	4A (SS-2), Speaker
F901	252049	4A (ST-6), Primary

G (220V) and Q (240V) models

Circuit no.	Parts no.	Description
F501, F601	252077	4A-SE-EAK, Speaker
F902	252074	2A-SE-EAK, Primary
F903, F904	252078	5A-SE-EAK, Secondary
F905	252070	1A-SE-EAK, Secondary



2. Replacing the lamp

This unit uses the lamp listed below.

Circuit no.	Parts no.	Description
PL901	210064A	PL 6.3V, 250mA, Dial plate illumination

3. Safety—check out

(Only U.S.A. model)

After correcting the original service problem, perform the following safety check before releasing the set to the customer.

Connect the insulating-resistance tester between the plug of power supply cord and nickel screw on the back panel.

Specifications: 3.3M Ω ±10% at 500V.

4. Removal of display pc board

- ①. Remove the five screws holding the top cover and chassis (side bracket:4 back panel: 1), and remove the top cover.
- ②. Remove the five screws holding the front panel and front bracket, and remove the front panel.
- ③. Remove the two screws holding the switch pc board and front bracket, and remove the switch pc board of U4.
- ④. Remove the four screws holding the holder and front bracket.
- ⑤. Remove the display pc board ass'y from the four nails of holder, and remove the holder.
- ⑥. Remove the two knobs (A805).
- ⑦. Remove the two screws holding the NAAF-2306 pc Board ass'y and center bracket, and remove the NAAF-2306.
- ⑧. Remove the four screws holding the switch of dynamic bass expander and front bracket, and remove the display pc board.

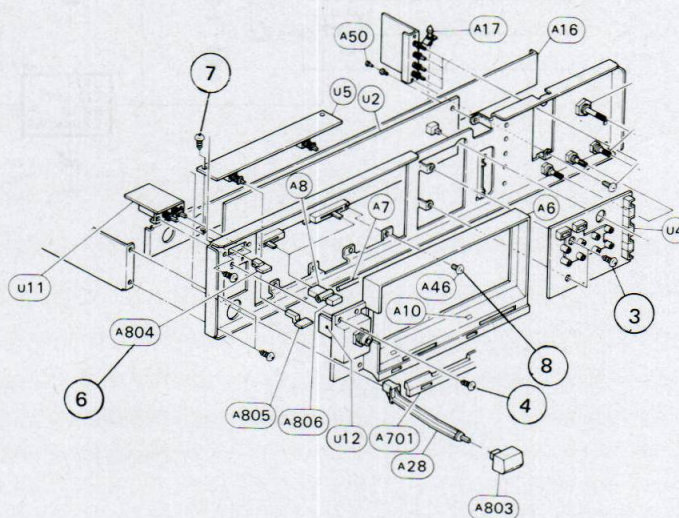
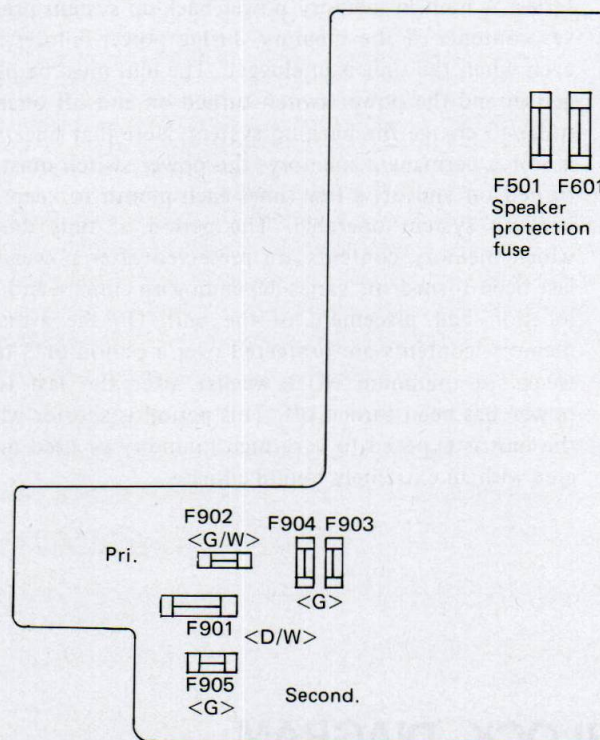

5. Memory preservation

This unit does not require memory preservation batteries. A built-in memory power back-up system preserves contents of the memory during power failures and even when the unit is unplugged. The unit must be plugged in and the power switch turned on and off once in order to charge the back-up system. Note that since this is not a permanent memory, the power switch must be turned on and off a few times each month to keep the back-up system operable. The period of time during which memory contents are preserved after power has last been turned off varies depending on climate and the location and placement of the unit. On the average, memory contents are protected over a period of 3 to 4 weeks (a minimum of 2 weeks) after the last time power has been turned off. This period is shorter when the unit is exposed to very high humidity or used in an area with an extremely humid climate.

BLOCK DIAGRAM

—AMPLIFIER SECTION—

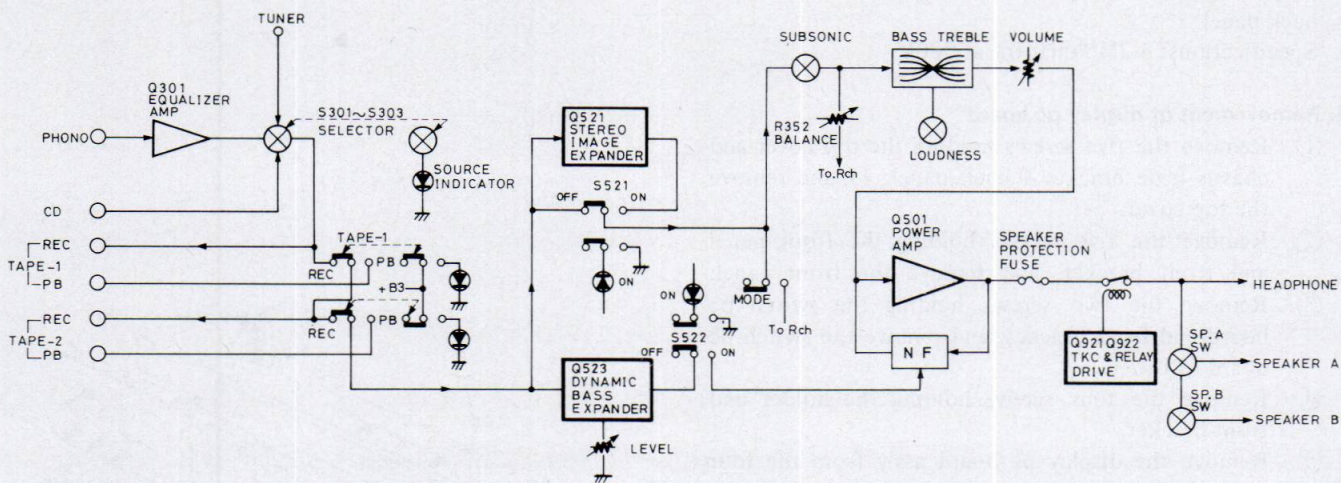

—POWER SUPPLY SECTION—
—120V MODEL—

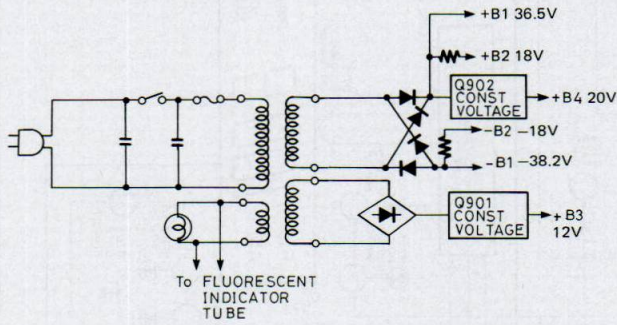

—220V MODEL—

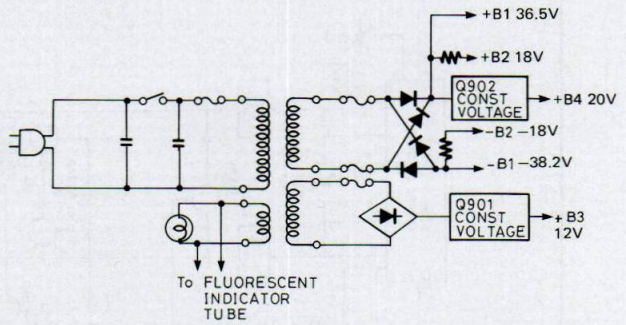

—DYNAMIC BASS EXPANDER—

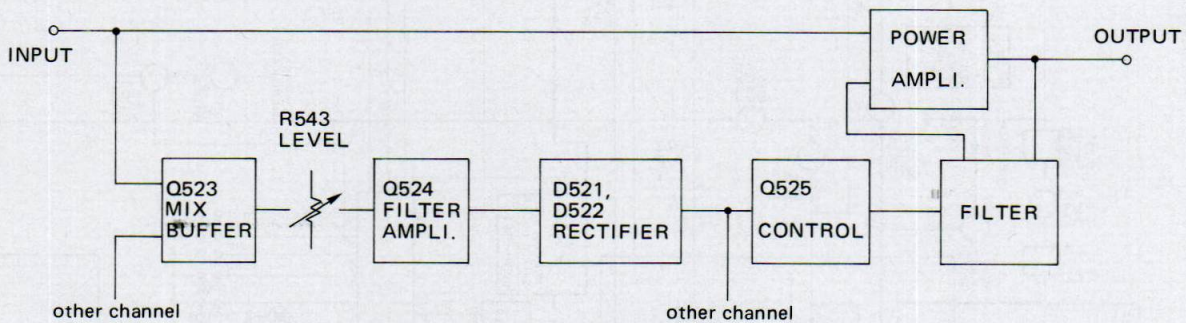

In earlier super base systems, only the frequencies about 70Hz were boosted by about 4dB to expand the playback frequency response to enable playback of the super low region. However, when there was no input signal, the above frequency response resulted in deterioration in the S/N ration in the 70Hz region. This problem has been overcome by the dynamic bass expander where the 70Hz boosted level is varied according to the input signal level. That is, the frequency response remains flat when no input signal is applied, but is boosted at the 70Hz region to the specified level when the input signal exceeds a certain level. The left and right channel input signals from the INPUT terminals are mixed by Q523 and pass through the level volume and filter amplifier. The signal is rectified by D521 and D522, and the resultant DC component control signal is applied to the gate of Q525. When the input signal is at an adequate level, Q525 is turned on and the super base circuit of power amplifier is controlled by the input signal.

BLOCK DIAGRAM

-TUNER SECTION-
-120V MODEL-

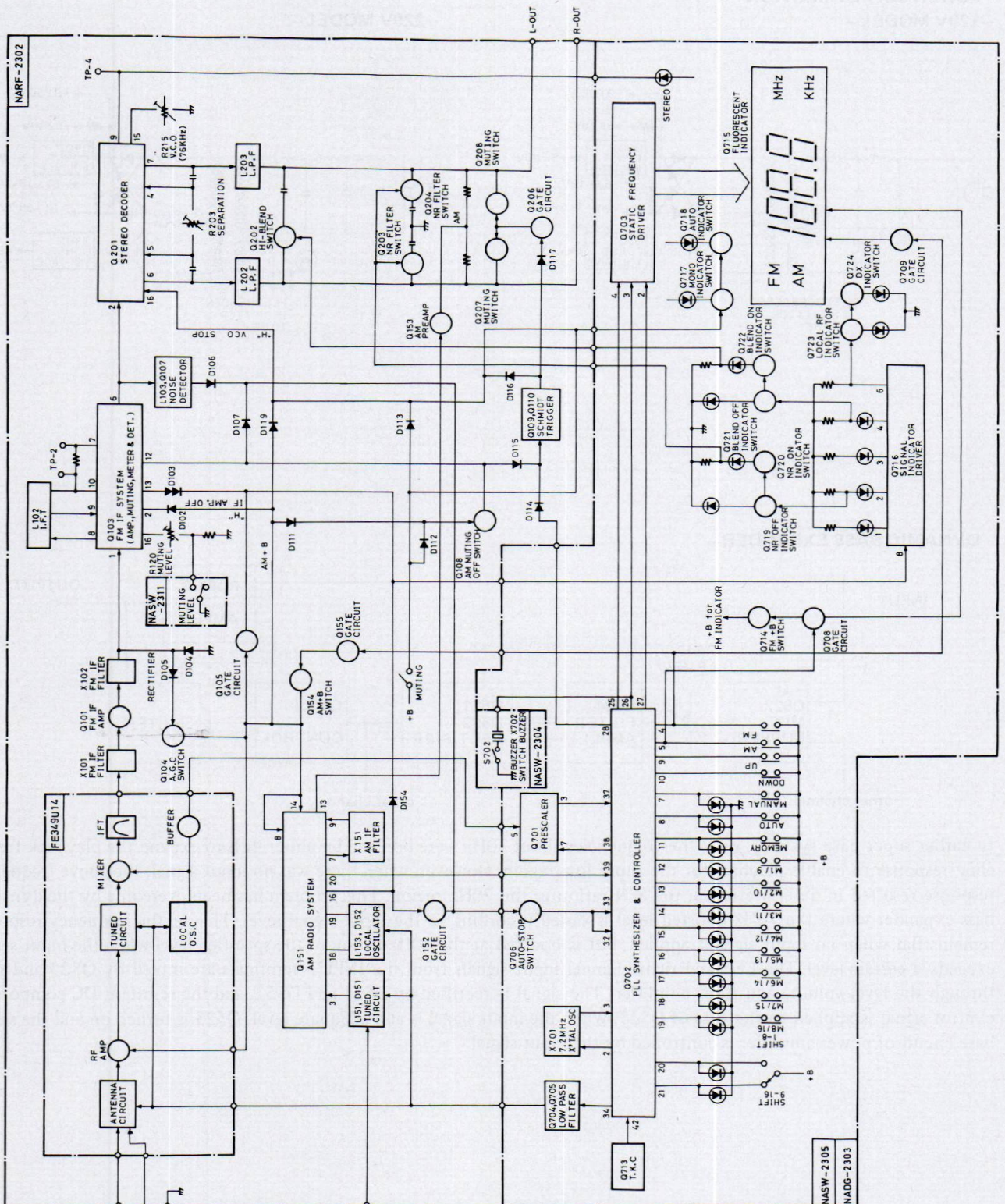

NARF-2302

NASW-2305
NADG-2303

BLOCK DIAGRAM

-TUNER SECTION-
-220V MODEL-

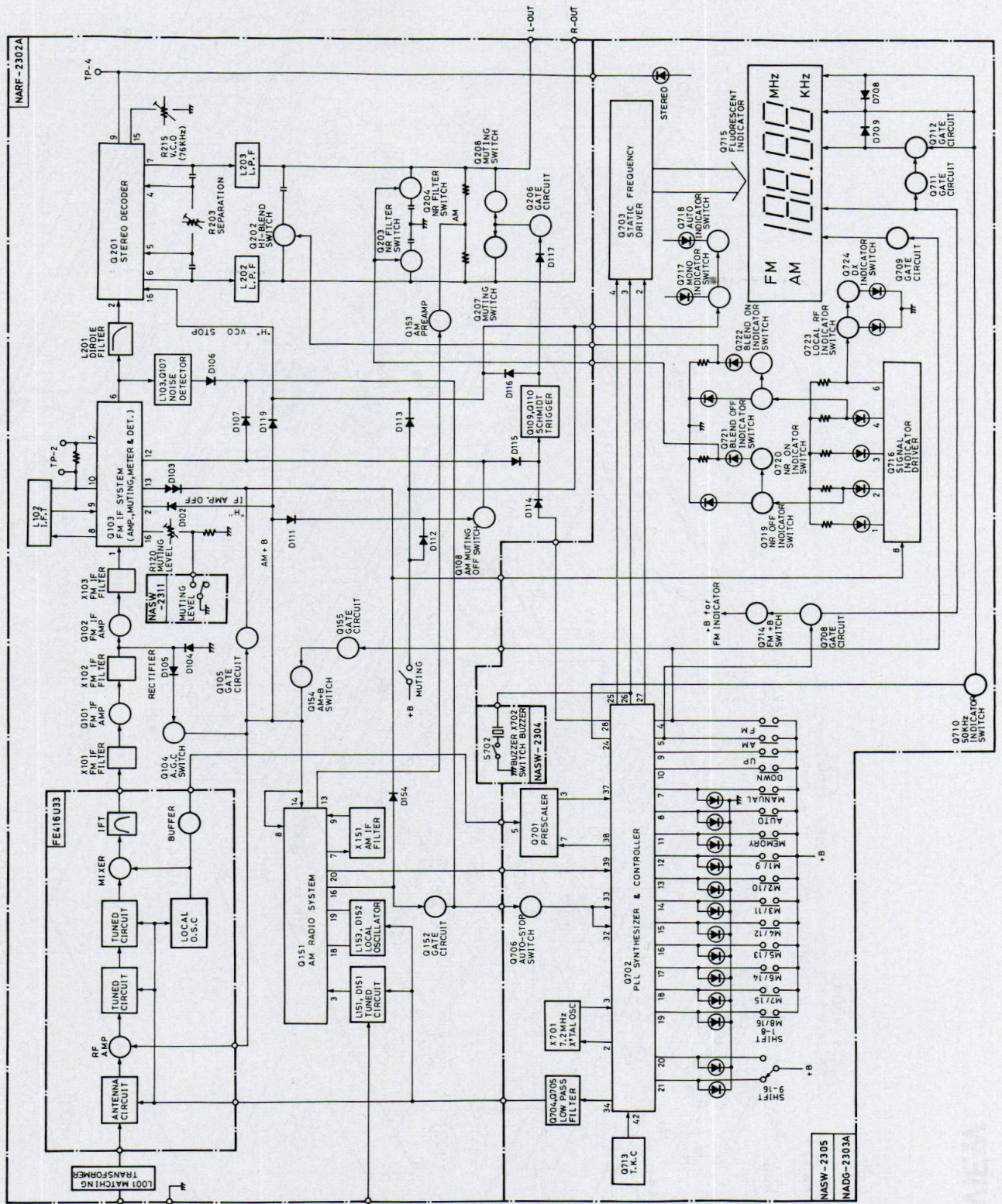

EXPLODED VIEW

EXPLODED VIEW

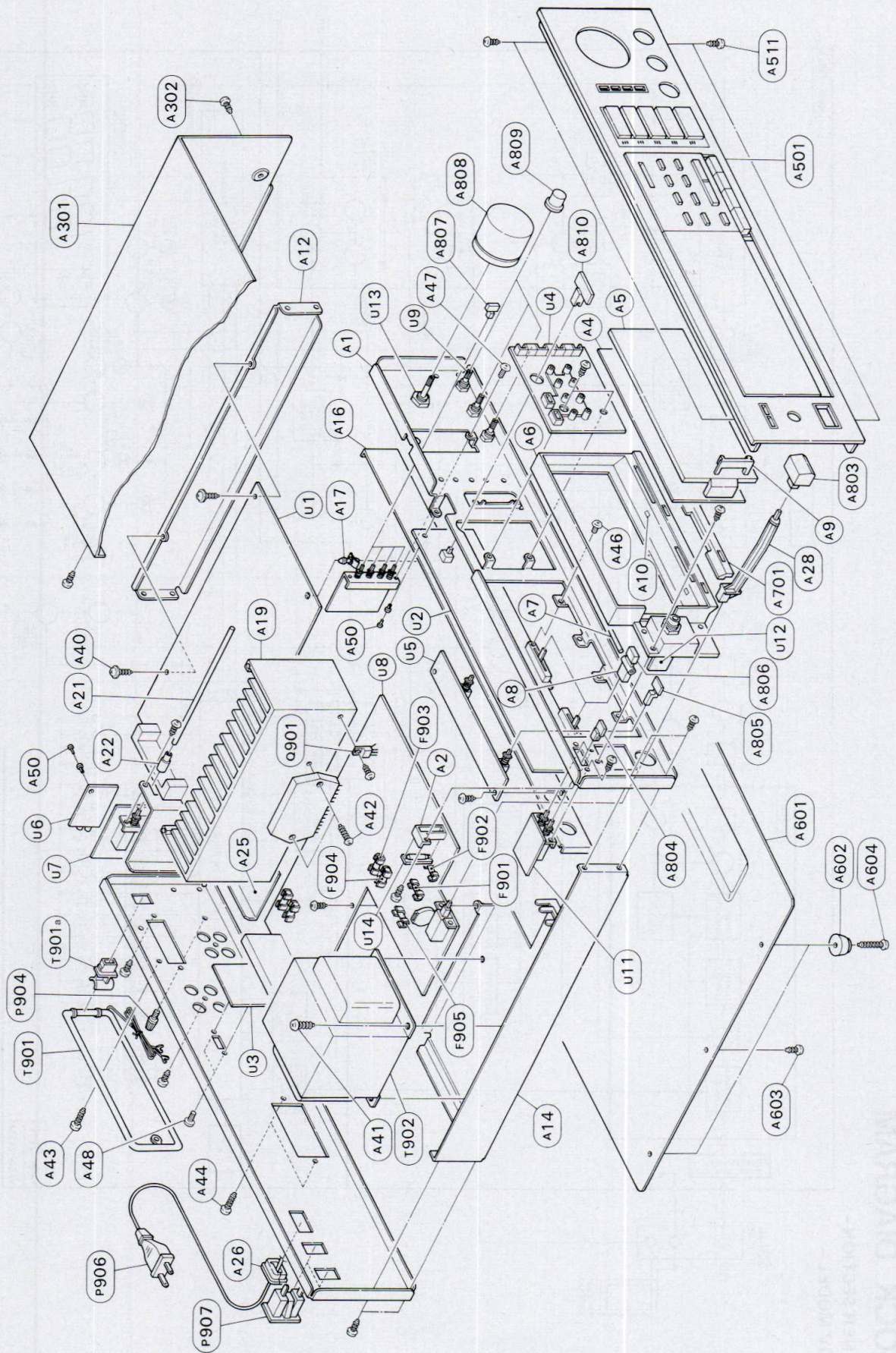

BLOCK DIYEREN

PARTS LIST

REF. NO.	PART NO.	DESCRIPTION	REF. NO.	PART NO.	DESCRIPTION
A1	27110243	Front bracket	U1	18408502	NARF-2302, Tuner circuit pc board ass'y (D)
A2	27190198A	Holder, lamp		18414502A	NARF-2302A, Tuner circuit pc board ass'y (G)
A4	28133131	Back plate	U2	18408503	NADG-2303, Digital circuit pc board ass'y (D)
A5	28130224	Dial plate		18414503A	NADG-2303A, Digital circuit pc board ass'y (G)
A6	27190357A	Holder	U3	18408504	NASW-2304B, Buzzer switch pc board ass'y
A7	27260171B	Shaft	U4	18408505	NASW-2305, Operation switch pc board ass'y
A8	27220032A	Slider	U5	18408506	NAAF-2306, Dynamic bass and stereo image expander circuit pc board ass'y
A9	27190359A	Holder, dial	U6	18408507	NAEQ-2307, Equalizer amplifier pc board ass'y (D)
A10	28198632	Facet		18414507A	NAEQ-2307A, Equalizer amplifier pc board ass'y (G)
A12	27115180	Side bracket R	U7	18408508	NASW-2308, Source selector switch pc board ass'y (D)
A14	27130388	Bracket, power transformer		18414508A	NASW-2308A, Source selector switch pc board ass'y (G)
A16	27130390A	Bracket, center	U8	18408509	NAAF-2309, Power amplifier and power supply pc board ass'y (D)
A17	27190011	Holder		18414509A	NAAF-2309A, Power amplifier and power supply pc board ass'y (G)
A19	27160162A	Radiator	U10	18408511	NASW-2311, Switch pc board ass'y
A21	27260172	Shaft	U11	18408512	NASW-2312, Speaker switch pc board ass'y
A22	28320135	Connector	U12	18408513	NAHP-2313, Headphone terminal pc board ass'y
A24	27120685B	Back panel (D)	U13	18408514	NAVR-2314, Volume control pc board ass'y
A25	27120687	Back panel (G)	U14	18414516	NAPL-2316, Edge light pc board ass'y
A26	27130389B	Bracket B			
A28	27273030C	Strainrelief			
A30	27150202	Shielded plate			
A38	834430068	3TTS+6B(BC), Tapping screw			
A40	831130088	3TTW+8B, Tapping screw			
A41	838440089	4TTB+8C(BC), Tapping screw			
A42	834430168	3TTS+16B(BC), Tapping screw			
A43	834230108	3TTS+10B(Ni), Nickel screw (D)			
A44	834430108	3TTS+10B(BC), Tapping screw			
A46	82142003	2P+3F(BC), Pan head screw			
A47	82143006	3P+6FN(BC), Pan head screw			
A48	82142604	2.6P+4F(BC), Pan head screw			
A50	880004	Rivet			
A301	28184271	Top cover (S)			
	28184272	Top cover (B)			
A302	834430068	3TTS+6B(BC), Tapping screw			
A501	18408121	Front panel ass'y (S)			
A501a	27267387	Guide, speaker			
A501b	27267386B	Guide, power			
A501c	27267398	Guide, loudness			
A501d	28191312	Clear plate			
A501e	28321992A	Selector knob ass'y			
A501f	28321998A	Knob ass'y			
A501	18428121	Front panel ass'y (B)			
A501a	27267390	Guide, speaker			
A501b	27267389B	Guide, power			
A501c	27267399	Guide, loudness			
A501d	28191313	Clear plate			
A501e	27110243	Front bracket			
A501f	28133131	Back plate			
A501g	28130224	Dial plate			
A501h	27190357A	Holder			
A501i	27260171B	Shaft			
A501j	27220032A	Slider			
A501k	27190359A	Holder, dial			
A501l	28198632	Facet			
A501m	27115180	Side bracket R			
A501n	27130388	Bracket, power transformer			
A501o	27130390A	Bracket, center			
A501p	27190011	Holder			
A501q	27160162A	Radiator			
A501r	27260172	Shaft			
A501s	28320135	Connector			
A501t	27120685B	Back panel (D)			
A501u	27120687	Back panel (G)			
A501v	27130389B	Bracket B			
A501w	27273030C	Strainrelief			
A501x	27150202	Shielded plate			
A501y	834430068	3TTS+6B(BC), Tapping screw			
A501z	831130088	3TTW+8B, Tapping screw			
A502	838440089	4TTB+8C(BC), Tapping screw			
A503	834430168	3TTS+16B(BC), Tapping screw			
A504	834230108	3TTS+10B(Ni), Nickel screw (D)			
A505	834430108	3TTS+10B(BC), Tapping screw			
A506	82142003	2P+3F(BC), Pan head screw			
A507	82143006	3P+6FN(BC), Pan head screw			
A508	82142604	2.6P+4F(BC), Pan head screw			
A509	880004	Rivet			
A510	28184271	Top cover (S)			
A511	28184272	Top cover (B)			
A512	834430068	3TTS+6B(BC), Tapping screw			
A513	18408121	Front panel ass'y (S)			
A514	27267387	Guide, speaker			
A515	27267386B	Guide, power			
A516	27267398	Guide, loudness			
A517	28191312	Clear plate			
A518	28321992A	Selector knob ass'y			
A519	28321998A	Knob ass'y			
A520	18428121	Front panel ass'y (B)			
A521	27267390	Guide, speaker			
A522	27267389B	Guide, power			
A523	27267399	Guide, loudness			
A524	28191313	Clear plate			

NOTE: (D): Only 120V model
 (G): Only 220V model
 (B): Only black model
 (S): Only silver model

NOTE: THE COMPONENTS IDENTIFIED BY MARK Δ ARE CRITICAL FOR RISK OF FIRE AND ELECTRIC SHOCK. REPLACE ONLY WITH PARTS NUMBER SPECIFIED.

CIRCUIT DESCRIPTION

1. Synthesizer and controller operation

Pin No.	Symbol	Terminal	Description
1	GND	Ground	
2	XT	X'tal	Connected to the 7.2MHz crystal oscillator for the reference frequency.
3	XT		
4	FM	FM band specification input	Mutual reset type, performs switching of each band, FM/MW/LW.
5	MW	MW band specification input	
6	LW	LW band specification input	
7	MANUAL	Manual tuning mode specification input	Mutual reset type, performs auto search and manual operation mode switching during UP/DOWN tuning.
8	AUTO	Auto search tuning mode specification input	
9	UP	UP tuning key input	Connect the push key and perform UP/DOWN tuning.
10	DOWN	DOWN tuning key input	
11	STO	Memory store command input	The preset memory is set to the write mode when the key is pressed.
12-19	M1-M8	Preset memory channel specification input	Controls the write and read out of the internal 16-station preset memory along with the MC1 and MC2 input.
20	MC-1	Memory control input	Set the 16-station preset memory to the 8 FM/8 AM station mode or the FM/MW/LW 3-band 16-station random mode. The 8 FM/8 AM mode is used in this unit.
21	MC-2		
22	OSC2	AM oscillator terminal	CR connection terminal for the oscillator that determines the scan speed during the AM search mode.
23	OSC1	FM oscillator terminal	CR connection terminal for the oscillator that determines the scan speed during the FM search mode.
24	0/5	FM 50 kHz output	Output that represents the 50kHz FM band tuning step for European models. Goes to the high level for the 50 kHz setting.
25	CK2	Tuned frequency data output	Outputs the serial data and timing clock to the tuned frequency display driver.
26	CK1		
27	DATA		
28	MUTE	Muting signal output	Goes to the high level during muting output.
29	E2	Regin specification input	See table 1.
30	E1		
31	STOP 3	AM IF signal input	During AM reception, this counts the IF signal and stops auto search.
32	STOP 2	Auto search stop signal input	When the stop 1 input (pin 33) is at the high level and this terminal goes to the high level, auto search is stopped.
33	STOP 1	Scan speed slow input	When the high level is input at this terminal, the auto search speed is cut in half.

Pin No.	Symbol	Terminal	Description
34	DO1	Error output	Charge pump output of the phase detector which constitutes the PLL. High level is output when the divided oscillation frequency is high than the reference frequency. In the opposite case, low level is output. Floating occurs when the frequencies match. The output is applied to the variable capacitor diode in the front end through low pass filter Q704 and Q705. The output from both terminals is the same, but only DO1 is used.
35	DO2		
36	TEST	Test terminal	Test mode at the high level.
37	FM IN	FM programmable counter input	Connect to the prescaler output (Pin3 of Q701)
38	PSC	Pulse swallow control output	Output to the control the division ratio of the prescaler.
39	AM IN	AM local oscillator signal input	Terminal for input of AM broadcast signal.
40	$\overline{\text{INH}}$	Inhibit input	Operates normally at the high level. Inhibit status at the low level.
41	$\overline{\text{INT}}$	Initialize input	Operates normally at the high level. At the low level, the internal status is initialized.
42	V _{DD}	Power supply	Device power terminal; supplies 5V during the normal operation and 2.5V from the super capacitor (C712) for memory preservation.

table 1.

E1 (Pin 30)	E2 (Pin 29)	Region	Band	Frequency range	Intermediate frequency	Scan step	Reference frequency
0	1	U.S.A	FM	87.5 ~ 108.0 MHz	+10.7 MHz	100 kHz	25 kHz
			AM1	520 ~ 1 710 kHz	+450 kHz	10kHz	10 kHz
1	1		AM2	522 ~ 1710 kHz	+450 kHz	9kHz	9kHz
1	0	Europe	FM	87.50 ~ 108.00 MHz	+10.7 MHz	50 kHz	25 kHz
			MW	522 ~ 1611 kHz	+450 kHz	9 kHz	9 kHz
			LM	153 ~ 360 kHz	+450 kHz	1 kHz	1 kHz
0	0	Japan	FM	76.0 ~ 90.0 MHz	-10.7 MHz	100 kHz	25 kHz
			AM	522 ~ 1611 kHz	+450 kHz	9 kHz	9 kHz

2. Auto Hi-blend and NR switch circuit

The Q103 FM IF system incorporates IC's with a built-in IF level detector with a 13 pin output.

If an input above 38dB enters the antenna, the 4 pin of Q716 signal driver becomes low level, the Q721 is turned on, the Q722 and Q202 are turned off and the high blend function is turned off.

If an input above 17dB enters the antenna, the 2 pin of Q716 signal driver becomes low level, the Q719 is turned on, the Q720, Q203 and Q204 are turned off and the NR function is turned off.

3. Auto search tuning circuit

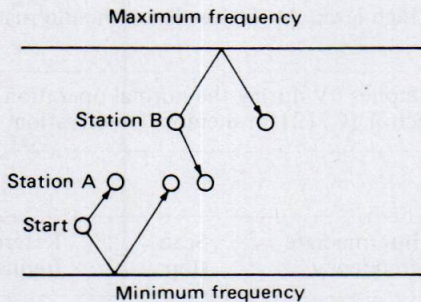
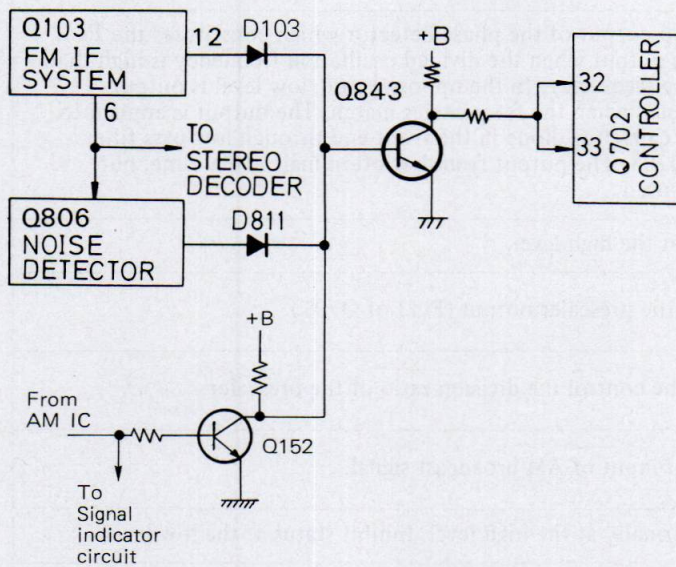

(fig. 4)

4. FM/AM switch circuit

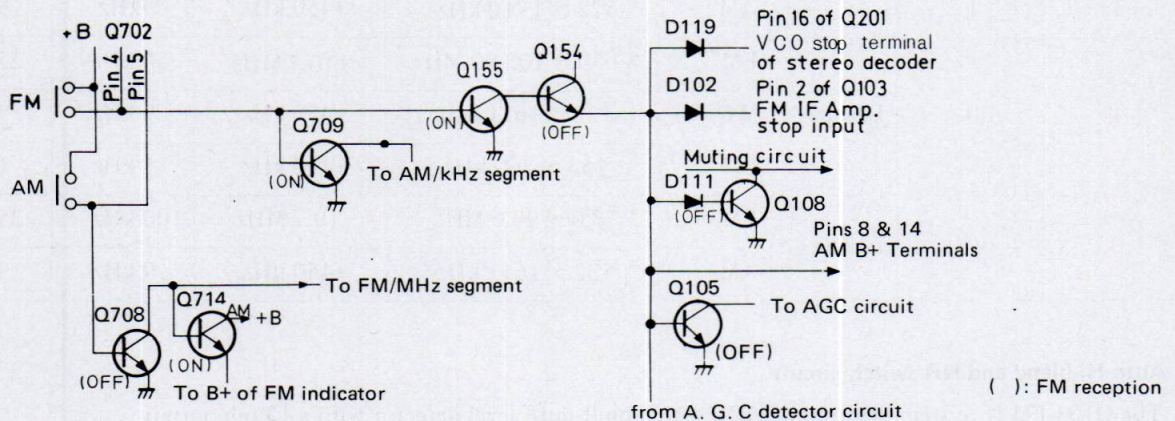

(fig. 5)

The FM/AM selector circuit is shown in the diagram. fig.5. Pins 4 and 5 of Q702 are of the mutual reset type. For FM, pin 4 is high and pin 5 is low; for AM, pin 4 is low and pin 5 is high. Because pin 5 is high and pin 4 is low during AM reception, Q709 is off, the AM, kHz segments of the fluorescent display are turned on. Also, since Q708 goes to on and Q714 is turned off, and the FM indicators are turned off. At the same time, Q155 is turned off and Q154 turned on, so +B is supplied to the power source terminal of the radio

During FM reception, this is operated by the IF level detection and zero point detection circuits included in the FM IF system IC of Q103 and by the noise component detection circuit of Q806. When a station is tuned, the output of all outputs go to the low level so Q843 goes from on to off, causing pins 32 and 33 of the controller IC to go to the high level to complete auto search tuning.

During AM reception, this is operated by the IF level detection included in the AM radio system IC of Q151. When a station is turned, Q152 goes from off to on and Q706 goes to off, causing pins 32 and 33 of the controller IC to go to the high level to complete auto search tuning.

- **Manual Tuning**

When the UP or DOWN key is pressed, the frequency goes up or down by one step. When either key is held down, the frequency rapidly increases or decreases (scans) and stops when the key is released. When either end of the turning range is reached, key input will no longer be received and the frequency will stop at the highest or lowest frequency.

- **Auto Tuning**

When the UP or DOWN key is pressed, scanning begins in the up or down direction, stopping where there is a radio station. Since auto scan is operated by a triangular wave, scanning is begun in the opposite direction the instant either end of the tuning range is reached. Also, if the UP or DOWN key is pressed when the tuned frequency is not at either end of the range, up or down scanning will begin.

system pins 8 & 14 of Q151.

Pin 16 of Q201 goes to the high level, the VCO oscillator stops, and pin 2 of Q103 goes to the high level so the FM IF amp is also switched off. Also, during AM reception, Q108 is turned on so the muting circuit is off. During FM reception, all of the switching transistors mentioned above perform the opposite operations to switch to the FM mode. Figures in parentheses indicate transistor operation during FM reception.

5. PLL tuned circuit

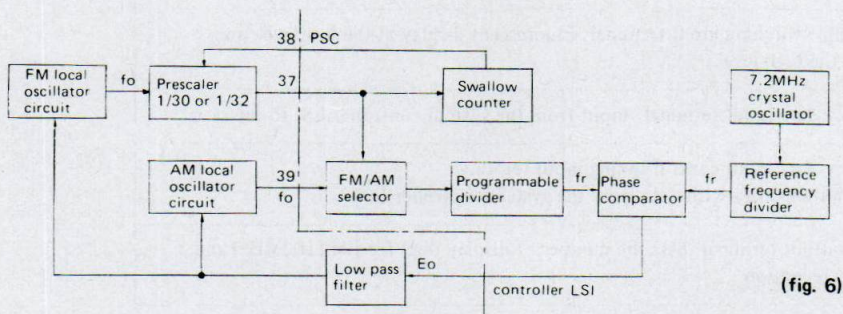

(fig. 6)

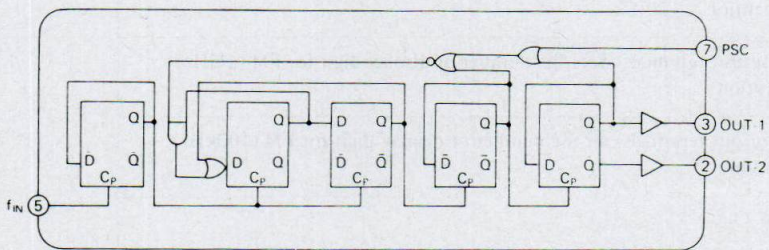

(fig 7) TD6104P (Prescaler)

A block diagram of the tuned circuit of the PLL is shown in figer 6.

Operation during AM reception

The reception frequency is applied to the programmable divider where it is divided to 1/N and output as fv. This is applied to the phase comparator where it is compared with frequency reference fr (9kHz for G/W model and 10kHz for D model). If fr and fv differ, Eo equal to the difference in frequency is output. Since error output Eo is a pulse waveform, it is passed through the low pass filter to change it into DC voltage V_D, which is applied to the variable capacitor diode in the front end to change the reception frequency. This continues until fv and fr are the same and Eo=0.

Operation during FM reception

The pulse swallow method is used in the prescaler of this unit. In this type of prescaler, a supplementary number

(changed according to the program code input) and the divided reception frequency from the prescaler are combined in the control counter and the prescaler's division factor is switched 1/30 or 1/32 according to external control (1/32 when the PSC terminal is "H" and 1/30 when it is "L").

The station oscillator frequency is applied of the programmable divider, but the programmable divider has an upper frequency limit of only 30MHz, so the pulse swallow-type prescaler, which can be used up to 150 MHz, is inserted for division to 1/Np;

The signal is applied to the programmable divider and divided to 1/N. The result is compared with a 25kHz frequency reference in the phase detector and the error is output as Eo until a match is obtained as in AM operation.

6. Frequency indicator circuit

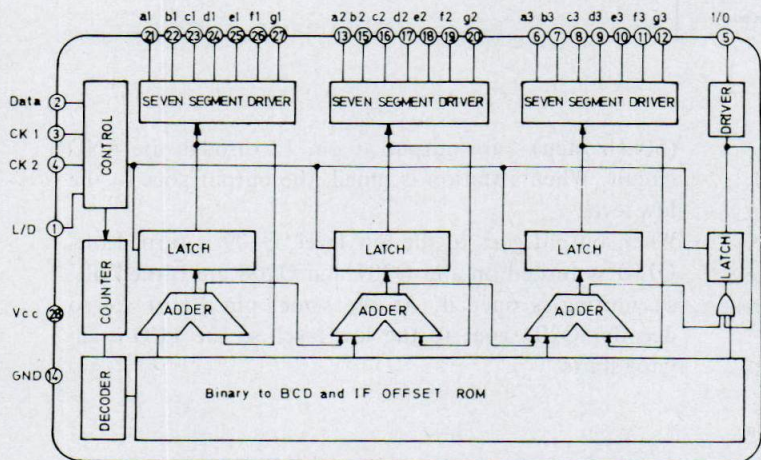

(fig. 8) TD6301AP block diagram

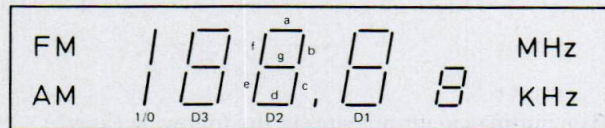

Pin No.	Terminal	Description
1	L/D	Output indication switching input terminal: Fluorescent display at the low level, and LED display at the high level.
2	Data	Tuned frequency data input terminal: Input from the system controller LSI to the serial.
3.4	CK1, CK2	Tuned frequency data input control timing input terminal: Transferred simultaneously with data from the system controller LSI.
5	1/0	Segment drive output terminal: Sets the number of display digit for FM (100MHz) and AM (1.000kHz) reception.
6-12	a3-g3	Seven segment drive output terminals: Sets the number of display digit for FM(10MHz) and AM (100kHz) reception.
13, 15-20	a2-g2	Seven segment drive output terminals: Sets the number of display digit for FM (1MHz) and AM (10kHz) reception
21-27	a1-g1	Seven segment drive output terminals; set the number of display digit for FM (100kHz) and AM (1kHz) reception
14	Vcc	Power source terminal
28	Gnd	Ground

7. Muting circuit

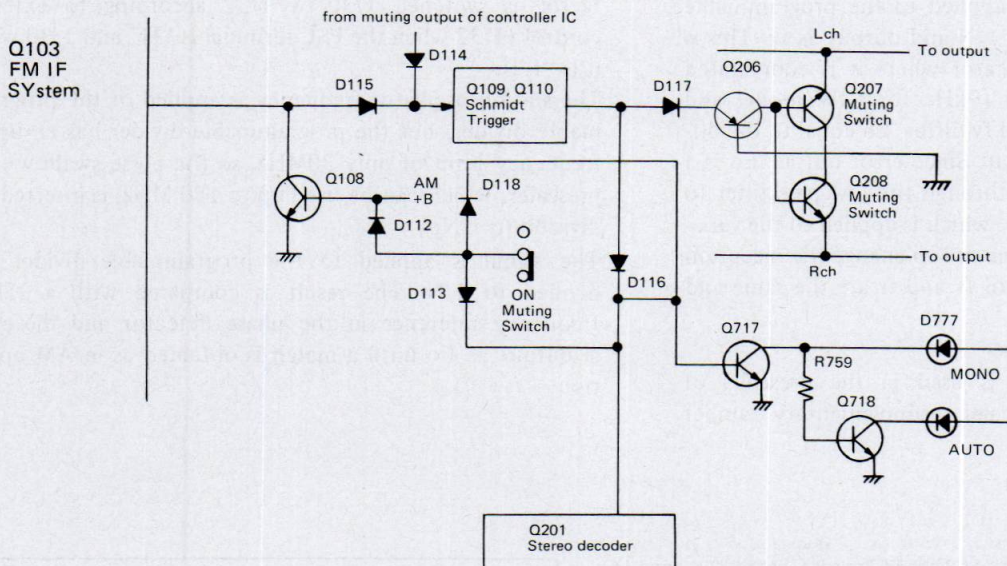

The muting circuit operates in the following cases.

1. While pin 28 of the controller IC outputs the high level, Q207 and Q208 are turned on and muting is closed in the following cases: (1) While the the manual UP/DOWN switch is being held down, (2) When a station in the memory is recalled, and (3) While a radio station is being received using auto search tuning.
2. When an FM station is not being received (and the muting switch is on).

The IF level in the FM IF system (set at R120 so muting is opened at 17 dBf (low position)) and zero point detection circuit (tuning point 55kHz (100kHz step): 30kHz

(50kHz step)– are output at pin 12 through the AND circuit. When a station is tuned, the output goes to the low level.

When output goes to the low level, Q109 is turned off, Q110 is turned on and Q207 and Q208 are turned off, so muting is opened. At the same, pin 16 of stereo decoder Q201 goes to the low level, so the VCO oscillator starts.

ADJUSTMENT PROCEDURES

FM section

Item	Step	Connection of instrument	FM SG output	Stereo modulator output	Turning dial setting	Output indicator	Adjustment	Adjust for	Remarks
FM RF	1	Fig. 1	—	—	88.0 MHz	Digital DC voltmeter	OSC	1.4V	Usually not necessary to adjust.
	2	Fig. 1	107.9 MHz 1 kHz, 75 kHz devi.	—	107.9 MHz	AC voltmeter	RF	Maximum output	
FM IF	1	Fig. 2	99.0 MHz 1 kHz, 75 kHz devi. 65 dBf (60 dB)	—	99.0 MHz	DC voltmeter	L102 Primary coil	0V	Muting switch : off Repeat the steps 1 and 2 until no further adjustment is necessary
	2	Fig. 2	—	—	99.0 MHz	Distortion analyzer	L102 Secondary coil	Minimum	
VCO	1	Fig. 3	99.0 MHz 1 kHz, 75 kHz devi. 65 dBf (60 dB)	—	99.0 MHz	Frequency counter	R215	19 kHz \pm 10 Hz	Muting switch : on
Distortion	1	Fig. 3	99.0 MHz 65 dBf (60 dB) Ext. modulation	L+R 1 kHz	99.0 MHz	Distortion analyzer	IF	Minimum	
	2	Fig. 3	99.0 MHz 65 dBf (60 dB) Ext. modulation	L ch. 1 kHz R ch. 1 kHz	99.0 MHz	R ch. AC voltmeter L ch. AC voltmeter	R203	Minimum Minimum	Maximum and same separation
Muting level	1	Fig. 2	99.0 MHz 17.2 dBf (12 dB) 1 kHz, 75 kHz devi.	—	99.0 MHz	Oscilloscope	R120	Signal output	Muting level: high
	2		99.0 MHz 16.2 dBf (11 dB) 1 kHz, 75 kHz devi.	—					

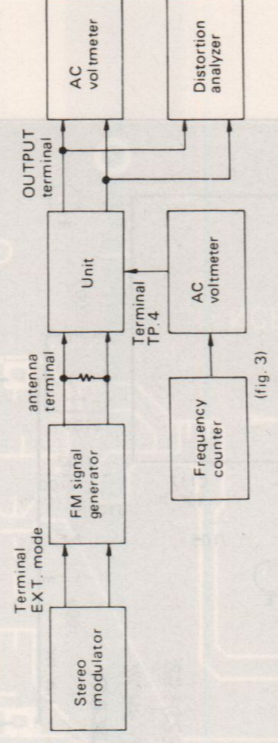
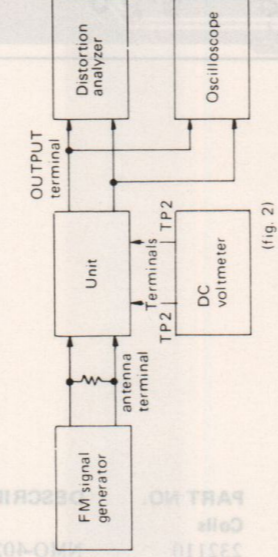
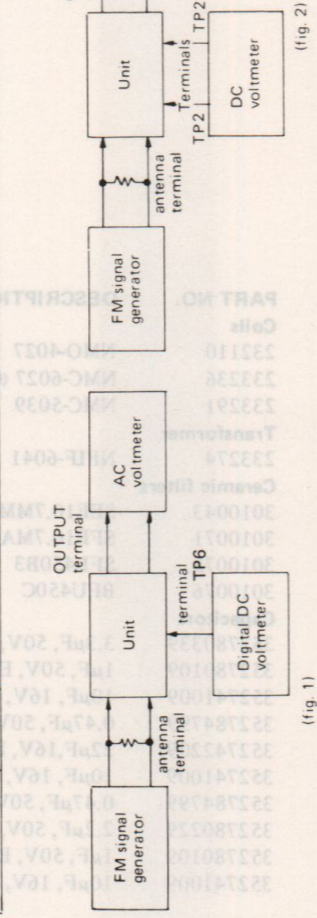

AM section

Step	AM SG output	Tuned frequency	Output indicator	Adjustment point	Adjust for	Remarks
1	522kHz (520kHz)	522kHz (520kHz)	Digital DC voltmeter	L153	1.2V	Repeat the steps 1 and 2 until no further adjustment is necessary.
2	1611kHz (1710kHz)	1611kHz (1710kHz)	Digital DC voltmeter	C170	9.0V (10.5V)	
3	603kHz (600kHz) 400Hz 30% mod.	603kHz (600kHz)	AC voltmeter	L151	Maximum	Repeat the steps 3 and 4 until no further adjustment is necessary.
5	999kHz (1000kHz) 400Hz 30% mod.	999kHz (1000kHz)	AC voltmeter	X151	Maximum	

() : 120V model < 10kHz step >

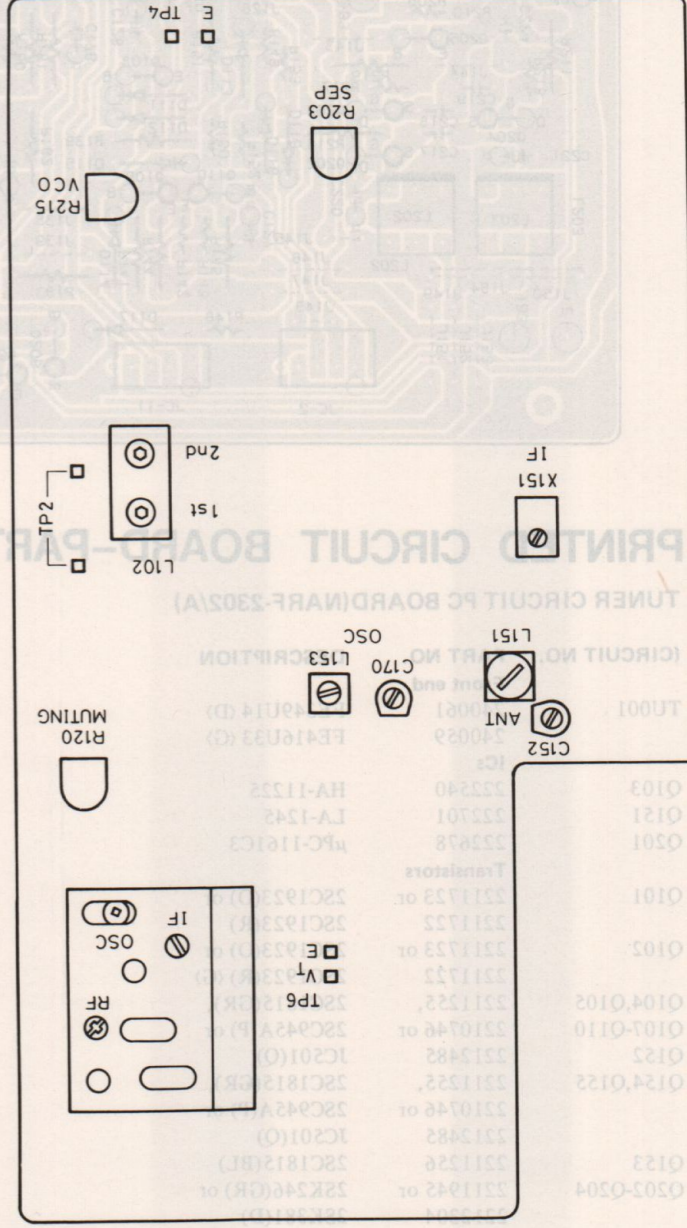

PRINTED CIRCUIT BOARD VIEW FROM BOTTOM SIDE

TUNER CIRCUIT PC BOARD

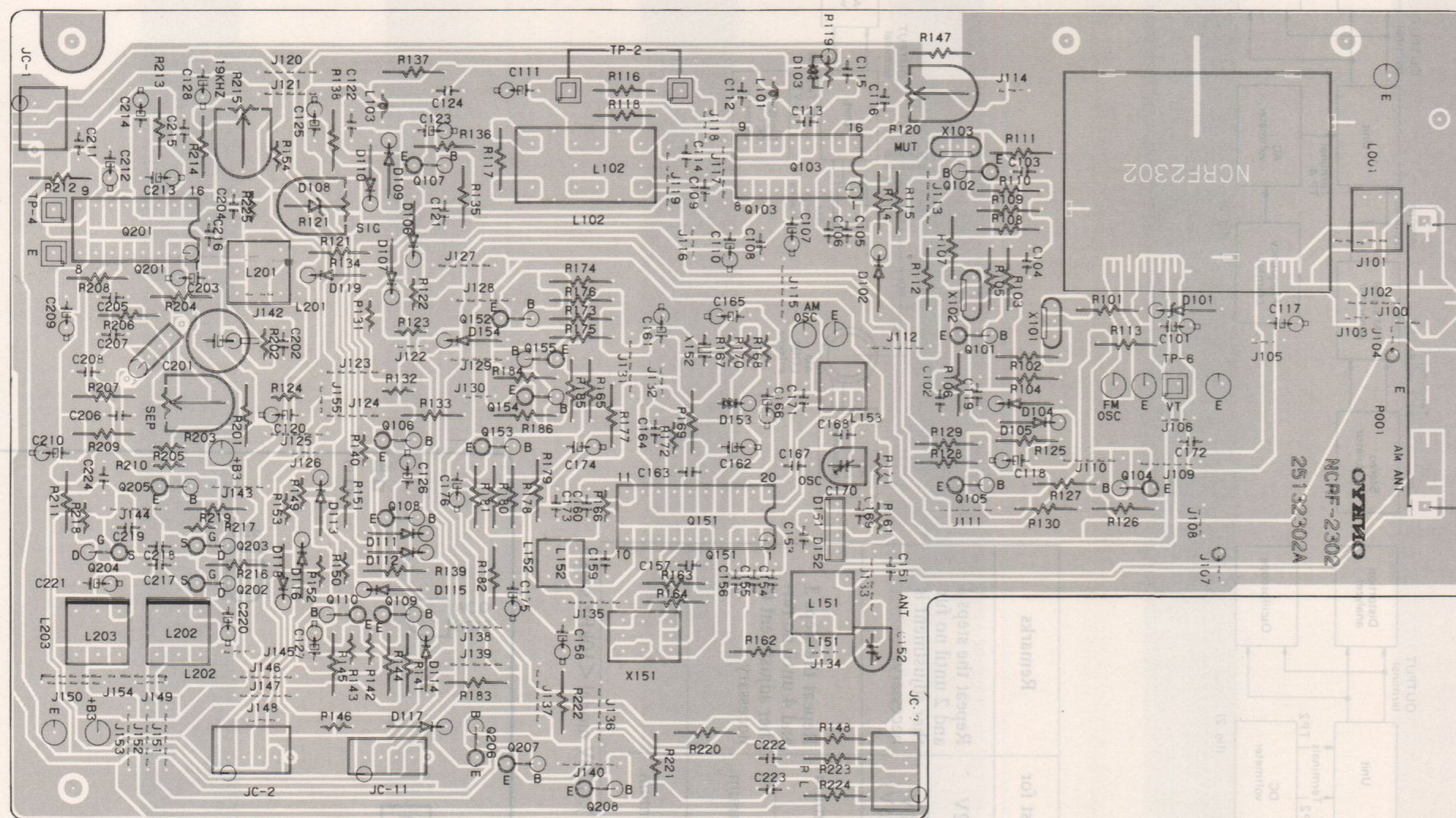

CIRCUIT NO.	PART NO.	DESCRIPTION
	Capacitors	
C152	3060010	NTC-20P09, Trimmer
C158	352741009	10μF, 16V, Elect.
C161	352744709	47μF, 16V, Elect.
C162	352780109	1μF, 50V, Elect..
C165,C166	352750479	4.7μF, 25V, Elect.
C168	370135114	510pF±5%, 100V, APS
C170	3060010	NTC-20P09, Trimmer
C174	352782299	0.22μF, 50V, Elect.
C175	352721019	100μF, 6.3V, Elect.
C176	352780339	3.3μF, 50V, Elect.
C201	352744719	470μF, 16V, Elect.
C203	352750479	4.7μF, 25V, Elect.
C209,C210	352741009	10μF, 16V, Elect.
C212	352782299	0.22μF, 50V, Elect.
C213	352780109	1μF, 50V, Elect.
C214	352780339	3.3μF, 50V, Elect.
C215	370134714	470pF±5%, 100V, APS
C220,C221	352780229	2.2μF, 50V, Elect.
	Resistors	
R120	5215045	N08HR10KBC, Semi-fixed
R203	5215048	N08HR200KBC, Semi-fixed
R215	5215044	N08HR5KBC, Semi-fixed
	Terminal	
P001	25060087	NTM-2PDMN31, Antenna (G)
	25060085	NTM-4PDMB29, Antenna (D)
	Sockets	
	25050141	NJPS-4P-S

(D): Only 120V model
(G): Only 220V model

PRINTED CIRCUIT BOARD-PARTS LIST

TUNER CIRCUIT PC BOARD(NARF-2302/A)

CIRCUIT NO.	PART NO.	DESCRIPTION
	Front end	
TU001	240061	FE349U14 (D)
	240059	FE416U33 (G)
	ICs	
Q103	222540	HA-11225
Q151	222701	LA-1245
Q201	222678	μPC-1161C3
	Transistors	
Q101	2211723 or 2211722	2SC1923(O) or 2SC1923(R)
Q102	2211723 or 2211722	2SC1923(O) or 2SC1923(R) (G)
Q104,Q105	2211255,	2SC1815(GR),
Q107-Q110	2210746 or	2SC945A(P) or
Q152	2212485	JC501(Q)
Q154,Q155	2211255,	2SC1815(GR),
	2210746 or	2SC945A(P) or
	2212485	JC501(Q)
Q153	2211256	2SC1815(BL)
Q202-Q204	2211945 or 2212304	2SK246(GR) or 2SK381(D)

CIRCUIT NO.	PART NO.	DESCRIPTION
	Transistors	
Q206	2211454 or 2212494	2SA1015(Y) or JA101(P)
Q207,Q208	2211705 or 2211706	2SD655(E) or 2SD655(F)
	Diodes	
D101	2243192 or 2239552	MTZ8, 2B or RD8, 2EB2 (G)
D102,D106	223150,	US1040,
D109-D119	223145 or	1S2076TD or
D154	223124	IS2473
D103	4000068	VD1222
D104,D105	223132	1K60 (G)
D104,D105	223150,	US1040,
	223145 or	1S2076TD or
	223124	IS2473 (D)
D151,D152	223140	KV1236
	Coils	
L001	233312	NFA-3051 (G)
L101	233105 or 233024	NCCH-1005 or NCCH-1501
L103	233031	NMC-9-1
L151	232113	NMA-3049

CIRCUIT NO.	PART NO.	DESCRIPTION
	Coils	
L153	232110	NMO-4027
L201	233236	NMC-6027 (G)
L202,L203	233291	NMC-5039
	Transformer	
L102	233274	NFIF-6041
	Ceramic filters	
X101-X103	3010043	SEE10.7MM (G)
X101,X102	3010071	SFE10.7MA5 (D)
X151	3010075	SFL450B3
X152	3010076	BFU450C
	Capacitors	
C101	352780339	3.3μF, 50V, Elect.
C107,C110	352780109	1μF, 50V, Elect.
C111	352741009	10μF, 16V, Elect.
C117	352784799	0.47μF, 50V, Elect.
C118	352742209	22μF, 16V, Elect.
C120	352741009	10μF, 16V, Elect.
C123	352784799	0.47μF, 50V, Elect.
C125	352780229	2.2μF, 50V, Elect.
C126	352780109	1μF, 50V, Elect.
C128	352741009	10μF, 16V, Elect.

BUZZER SWITCH PC BOARD

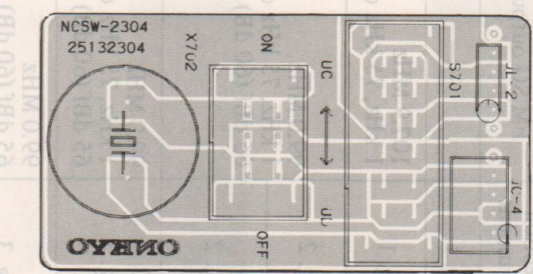

CIRCUIT NO.	PART NO.	DESCRIPTION
	BUZZER SWITCH PC BOARD(NASW-2304)	
X702	241048	PKM24-4A0, Buzzer
S702	250142	NSS-2225, Slide switch
	25050141	NJPS-4P-S, Socket, jumper

SCHEMATIC DIAGRAM

-TUNER SECTION-
-120V MODEL-

A
B
C
D
E

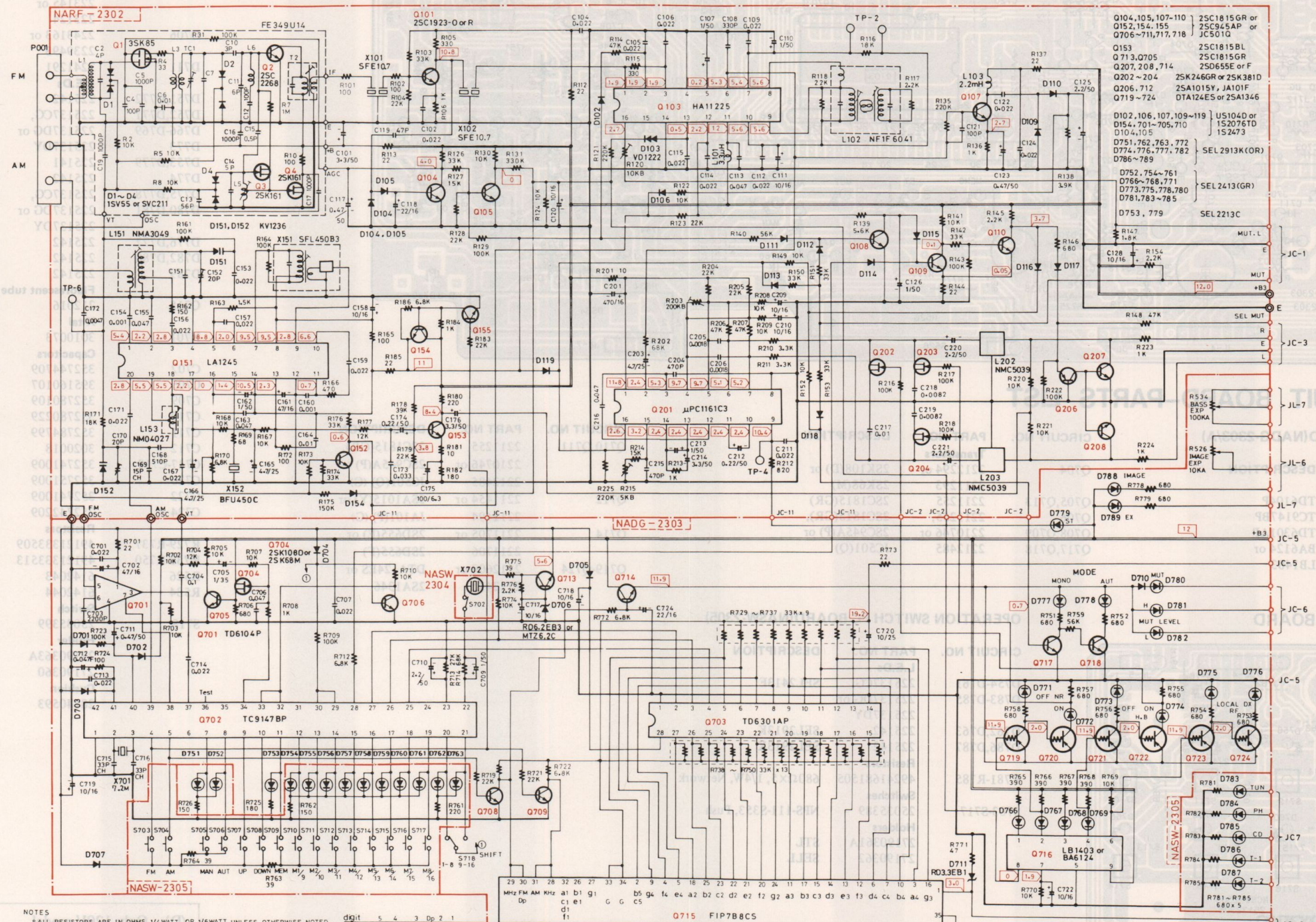

NOTES

- * ALL RESISTORS ARE IN OHMS, 1/4WATT OR 1/2WATT UNLESS OTHERWISE NOTED.
- * ALL CAPACITORS ARE IN μ F, 50V UNLESS OTHERWISE NOTED.
- * ELECTROLYTIC CAPACITORS (μ ED) ARE IN μ F/WV.
- * VOLTAGE (MEASURED WITH VTVM) AND INPUT SIGNAL.
- * CIRCUIT IS SUBJECT TO CHANGE FOR IMPROVEMENT.

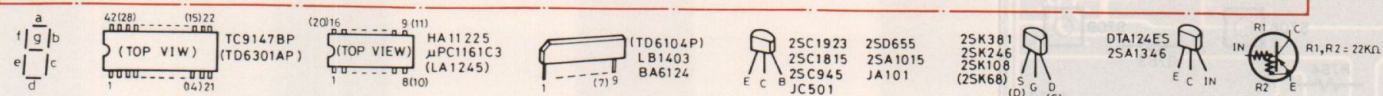
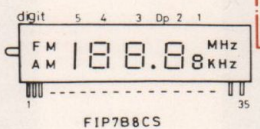

PRINTED CIRCUIT BOARD VIEW FROM BOTTOM SIDE

DIGITAL CIRCUIT PC BOARD

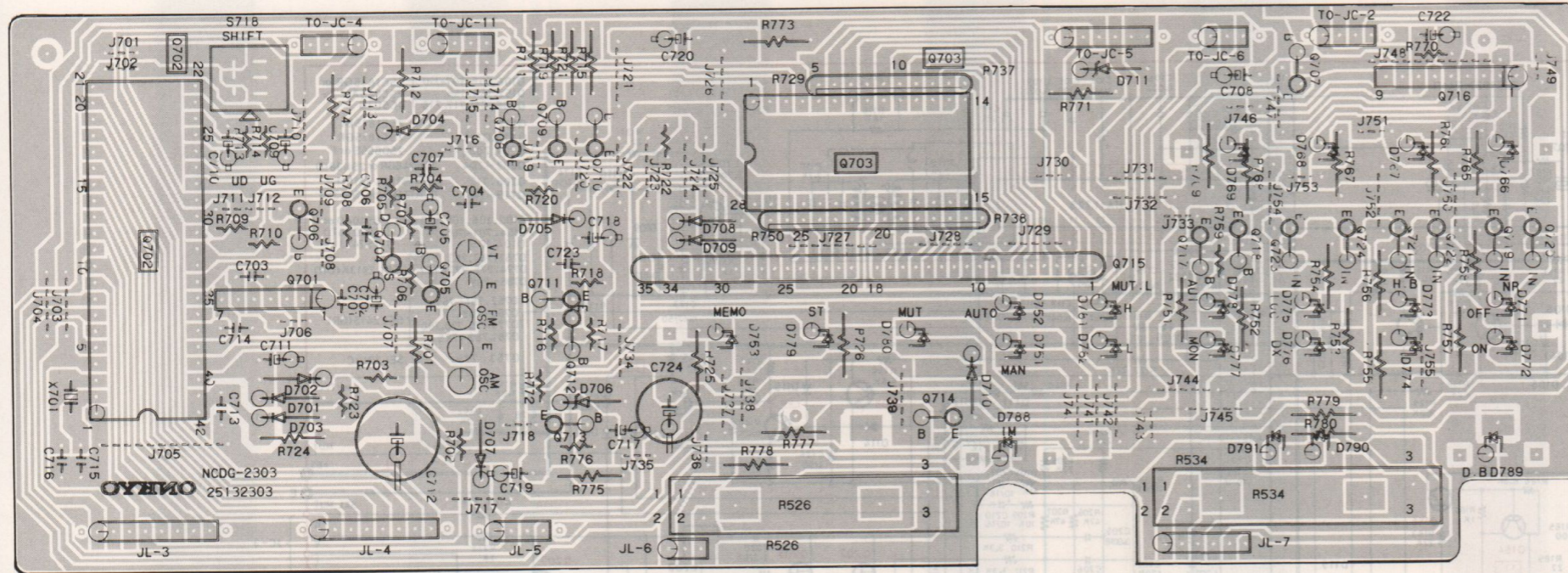

CIRCUIT NO. PART NO. DESCRIPTION

CIRCUIT NO.	PART NO.	DESCRIPTION
D701-D705	223150,	US1040,
D707,D710	223145 or	1S2076TD or
	223124	1S2473
D708,D709	223150,	US1040,
	223145 or	1S2076TD or
	223124	1S2473 (G)
D706	2243163 or	MTZ6.2C or
	2239493	RD6.2EB3
D711	2241291	RD3.3EB1
		L.E.Ds
D751,D772	225142	SEL2913K
D752,D771	225137CG,	SEL2413E
D766-D769	225137DG or	
D773	225137DY	
D753,D779	225141	SEL2213C
D774	225142	SEL2913K
D775,D778	225137CG,	SEL2413E
D780,D781	225137DG or	
	225137DY	
D776,D777	225142	SEL2913K
D782,D788	225142	SEL2913K
D789	225142	SEL2913K
		Fluorescent tube
Q715	212016	FIP-7B8CS
		X'tal
X701	3010073	XTL-7.2M

CIRCUIT NO.	PART NO.	DESCRIPTION
		Capacitors
C702	352744709	47μF, 16V, Elect.
C705	395160107	1μF, 35V, Tantalum
C709	352780109	1μF, 50V, Elect.
C710	352780229	2.2μF, 50V, Elect.
C711	352784799	0.47μF, 50V, Elect.
C712	3020018	0.047F, 5V, Super
C717-C719	352741009	10μF, 16V, Elect.
C720	352751009	10μF, 25V, Elect.
C722	352741009	10μF, 16V, Elect.
C724	352742209	22μF, 16V, Elect.
		Resistors
R729-R737	49121333509	33kΩ×9, 1/8W, Network
R738-R750	49121333513	33kΩ×13, 1/8W, Network
R526	6142043	N30LL10KA15Z, Slide variable
R534	6142044	N30LL100KA15Z, Slide variable
		Switch
S718	25035399	NPS-122-L364, Shift
		Holder
	27190363A	L.E.D
	27190360	EXL
		Cushion
	28140593	40×10×3.5

(D): Only 120V model
(G): Only 220V model

PRINTED CIRCUIT BOARD-PARTS LIST

DIGITAL CIRCUIT PC BOARD(NADG-2303/A)

CIRCUIT NO.	PART NO.	DESCRIPTION
Q701	222675	TD6104P
Q702	222674	TC9147BP
Q703	222673	TD6301AP
Q716	222670 or	BA6124 or
	222666	LB1403

CIRCUIT NO.	PART NO.	DESCRIPTION
Q704	2212294 or	2SK108(D) or
	2211293	2SK68(M)
Q705,Q713	2211255	2SC1815(GR)
Q706	2211255,	2SC1815(GR),
Q708,Q709	2210746 or	2SC945A(P) or
Q717,Q718	2212485	JC501(Q)

CIRCUIT NO.	PART NO.	DESCRIPTION
Q710,Q711	2211255,	2SC1815(GR),
	2210746 or	2SC945A(P) or
	2212485	JC501(Q) (G)
Q712	2211454 or	2SA1015(Y) or
	2212494	JA101(P) (G)
Q714	2211705 or	2SD655(E) or
	2211706	2SD655(F)
Q719-Q724	2212600 or	DTA124ES or
	221243	2SA1346

OPERATION SWITCH PC BOARD

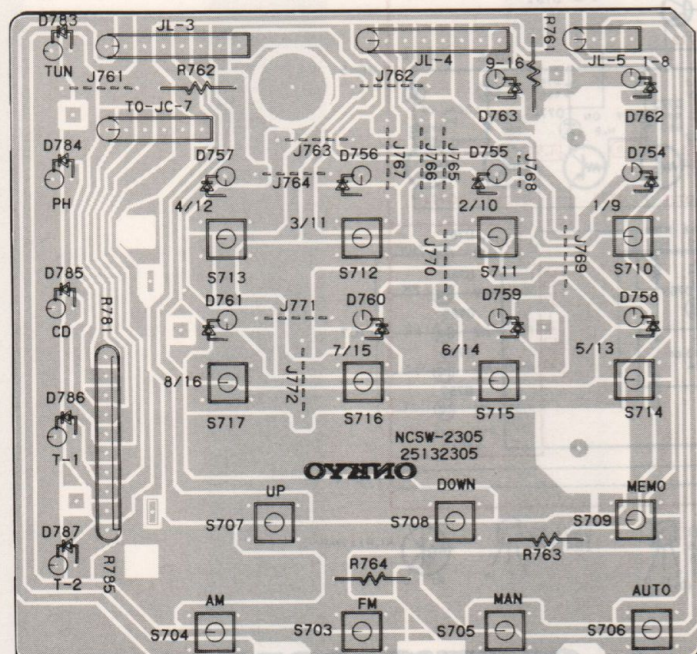

OPERATION SWITCH PC BOARD(NASW-2305)

CIRCUIT NO.	PART NO.	DESCRIPTION
D754-D761	225137CG,	SEL2413E
D783-D785	225137DG or	
	225137DY	
D762,D763	225142	SEL2913K
D786,D787	225142	SEL2913K
		Resistors
R781-R785	49241681505	680Ω×5, 1/4W, Network
		Switches
S703-S717	25035389	NPS-111-S353, Push
		Holders
	27190361A	STL
	27190362	SELL

SCHEMATIC DIAGRAM

-TUNER SECTION- -220V MODEL-

A

B

C

D

E

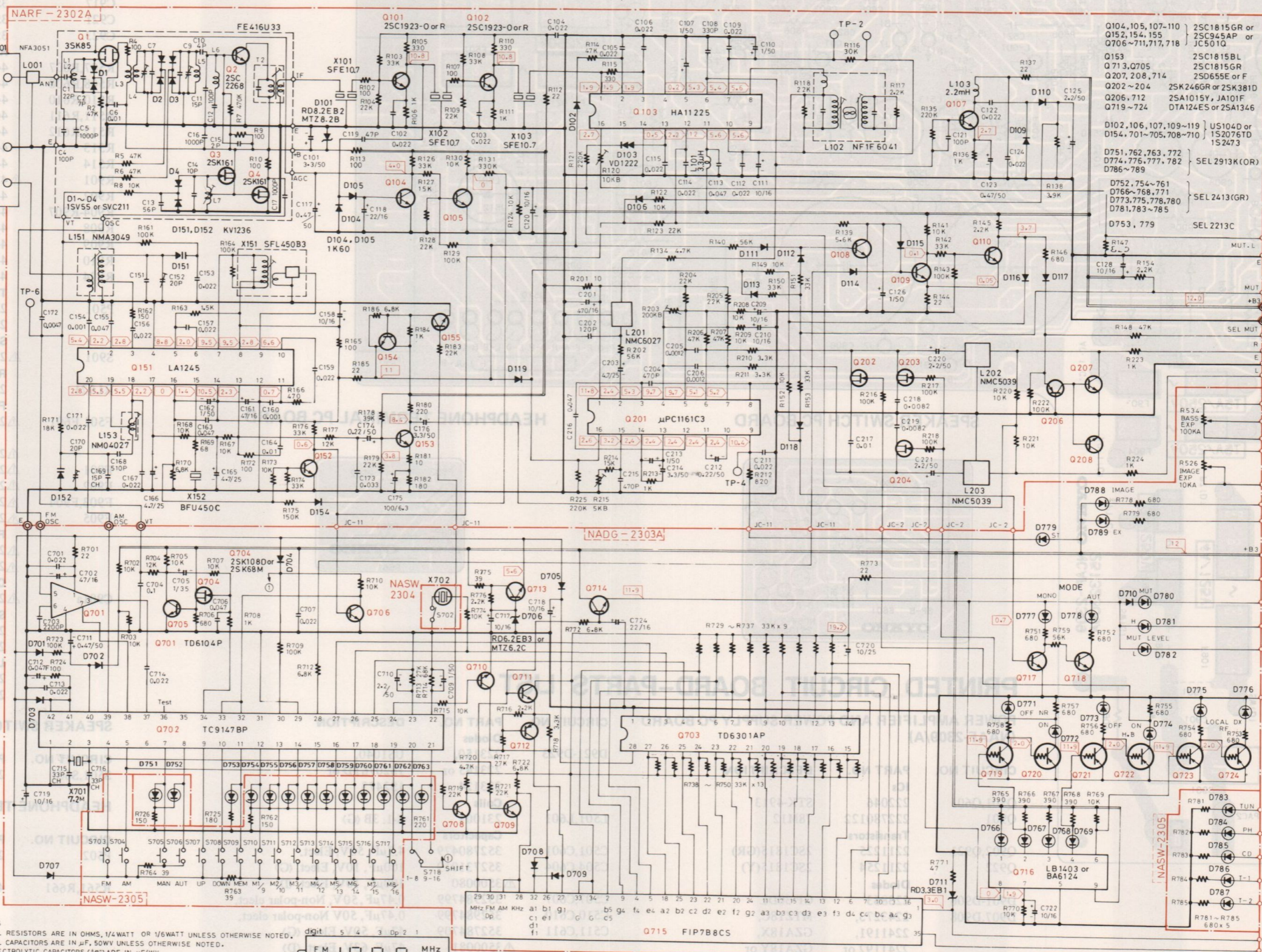

- NOTES
- * ALL RESISTORS ARE IN OHMS, 1/4WATT OR 1/6WATT UNLESS OTHERWISE NOTED.
 - * ALL CAPACITORS ARE IN μ F, 50V UNLESS OTHERWISE NOTED.
 - * ELECTROLYTIC CAPACITORS (E) ARE IN μ F/WV.
 - * VOLTAGE (MEASURED WITH VTM) (NO INPUT SIGNAL).
 - * CIRCUIT IS SUBJECT TO CHANGE FOR IMPROVEMENT.

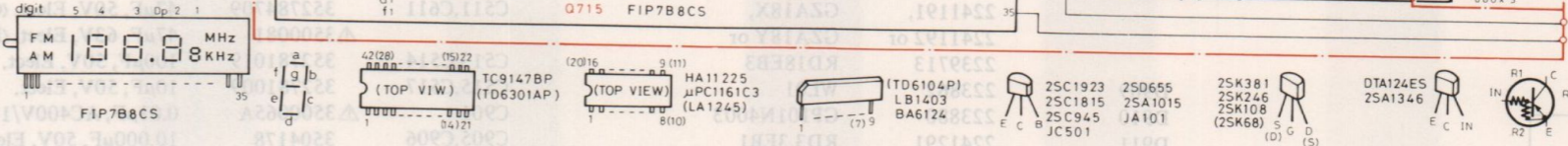

PRINTED CIRCUIT BOARD VIEW FROM BOTTOM SIDE

POWER AMPLIFIER AND POWER SUPPLY CIRCUIT PC BOARD

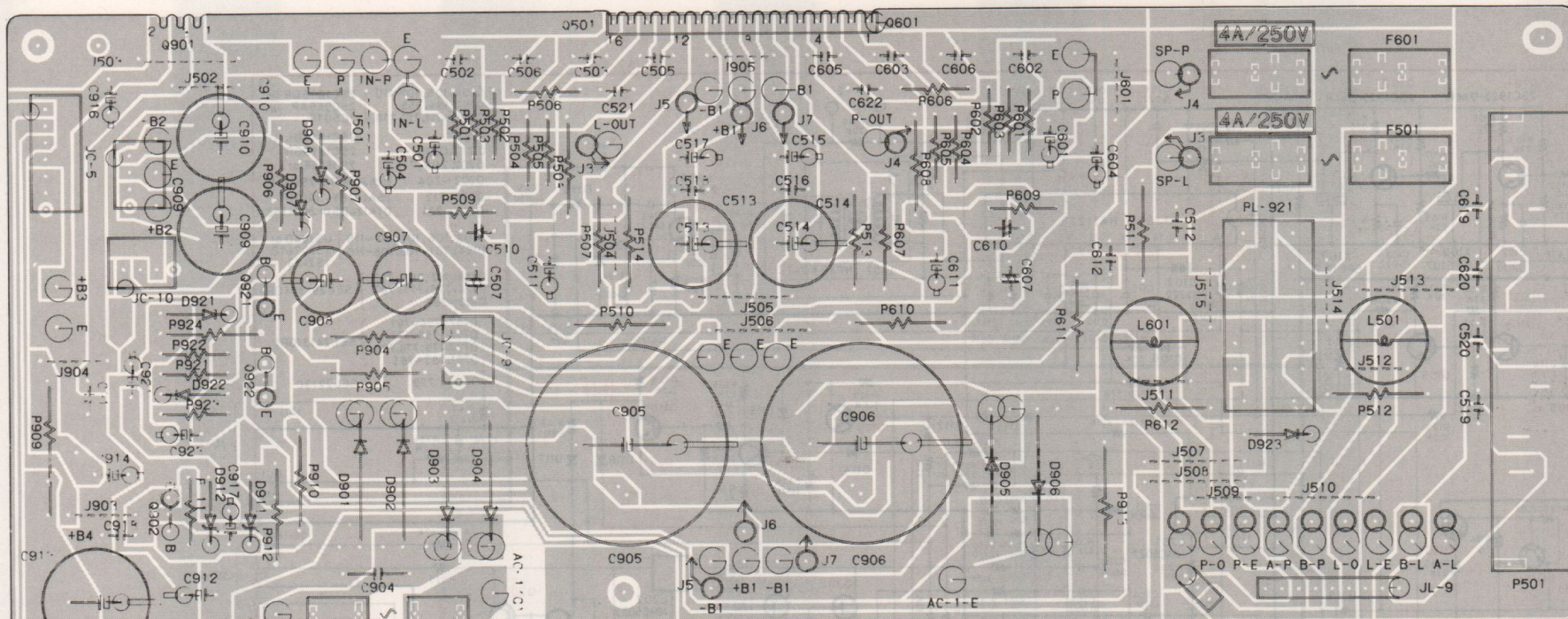

SPEAKER SWITCH PC BOARD

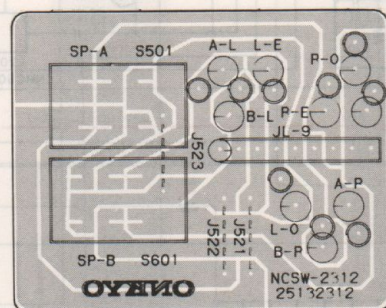

HEADPHONE TERMINAL PC BOARD

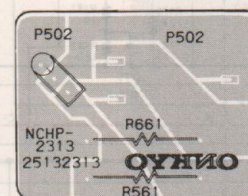

PRINTED CIRCUIT BOARD-PARTS LIST

POWER AMPLIFIER AND POWER SUPPLY PC BOARD (NAAF-2309/A)

CIRCUIT NO.	PART NO.	DESCRIPTION
		ICs
Q501,Q601	222046	STK-4913
Q901	222780122	78M12
		Transistors
Q902,Q921	2211225	2SC1815(GR)
Q922	2211254	2SC1815(Y)
		Diodes
D901-D906	223863	GP-30DL
D907,D908	2243273,	MTZ18C,
	2241191,	GZA18X,
	2241192 or	GZA18Y or
	2239713	RD18EB3
D909	223862	WL01
D910	223880	GP101N4003
D911	2241291	RD3.3EB1
D912	2239733 or	RD20EB3 or
	2243283	MTZ20C

CIRCUIT NO.	PART NO.	DESCRIPTION
D921-D923	223150, 223145 or 223124	US1040, 1S2076TD or 1S2473
		Coils
L501,L601	231001	S-1.3B (G)
		Capacitors
C501,C601	352780479	4.7μF, 50V, Elect.
C504,C604	352731019	100μF, 10V, Elect. (G)
	△3500080	100μF, 10V, Elect. (D)
C507,C607	352984799	0.47μF, 50V, Non-polar elect.
C510,C610	352984799	0.47μF, 50V Non-polar elect.
C511,C611	352784709	47μF, 50V, Elect. (G)
	△3500081	47μF, 63V, Elect. (D)
C513,C514	352781019	100μF, 50V, Elect.
C515,C517	352781009	10μF, 50V, Elect.
C901	△3500065A	0.01μF, AC400V/125V, IS
C905,C906	3504178	10,000μF, 50V, Elect.
C907,C908	352761019	100μF, 35V, Elect.
C909,C910	352752219	220μF, 25V, Elect.

CIRCUIT NO.	PART NO.	DESCRIPTION
		Capacitor
C912	352761019	100μF, 35V, Elect.
C913	352752229	2,200μF, 25V, Elect.
C914	352751019	100μF, 25V, Elect.
C916	352741009	10μF, 16V, Elect.
C917	352780109	1μF, 50V, Elect.
C921	352753309	33μF, 25V, Elect.
C923	352780339	3.3μF, 50V, Elect.
		Resistors
R507,R607	441521024	1kΩ, 1/2W, Metal oxide film
R508,R608	441523324	3.3kΩ, 1/2W, Metal oxide film
R510,R610	441522424	2.4kΩ, 1/2W, Metal oxide film
R511,R611	441520824	8.2Ω, 1/2W, Metal oxide film
R512,R612	441520474	4.7Ω, 1/2W, Metal oxide film (G)
R513	441525614	560Ω, 1/2W, Metal oxide film
R514	441522014	200Ω, 1/2W, Metal oxide film
R901	△431523355	3.3MΩ, 1/2W, Solid (D)
R902	441523904	39Ω, 1/2W, Metal oxide film
R904-R907	441526214	620Ω, 1/2W, Metal oxide film
R908	441621024	1kΩ, 1W, Metal oxide film
R909	441720474	4.7Ω, 2W, Metal oxide film
R910	441627514	750Ω, 1/2W, Metal oxide film
R924	441522704	27Ω, 1/2W, Metal oxide film
		Terminal
P501	25060058 25060092	NTM-8PDM125, Speaker NTM-1S33 (G)
		Switch
S901	△25035398	NPS-111-L362P, Power
		Relay
RL921	25065134	NRL-2P5A-DC24V-07
		Fuses
F501,F601	△252077	4A-SE-EAK, Speaker protection (G)
	△252059	4A(SS-2), Speaker protection (D)
F901	△252049	4A(ST-6), Primary (D)
F902	△252074	2A-SE-EAK, Primary (G)
F903,F904	△252078	5A-SE-EAK, Secondary (G)
F905	△252070	1A-SE-EAK, Secondary (G)
		Fuseholders
	△25050065	YSH403T (G)
	△250113	SN5051 (D)
		Cover
C901a	△27300601	SB-1925, Capacitor for C901
		Sockets
	25050140	NJPS-3P-S
	25050143	NJPS-6P-S
		Label
	29360374	T4A/250V, Fuse, rating (G)
	29360626-1	Fuse (D)

SPEAKER SWITCH PC BOARD (NASW-2312)

CIRCUIT NO.	PART NO.	DESCRIPTION
S501,S601	25035467	NPS-212-L429, Speaker switch

HEADPHONE TERMINAL PC BOARD (NAHP-2313)

CIRCUIT NO.	PART NO.	DESCRIPTION
P502	25045138	HLJ0520-01-010, Headphone terminal
R561,R661	441523914	390Ω, 1/2W, Metal oxide film resistor

NOTE: THE COMPONENTS IDENTIFIED BY MARK △ ARE CRITICAL FOR RISK OF FIRE AND ELECTRIC SHOCK. REPLACE ONLY WITH PARTS NUMBER SPECIFIED.

(D): Only 120V model
(G): Only 220V model

SCHEMATIC DIAGRAM

-AMPLIFIER SECTION-
-120V MODEL-

A

B

C

D

E

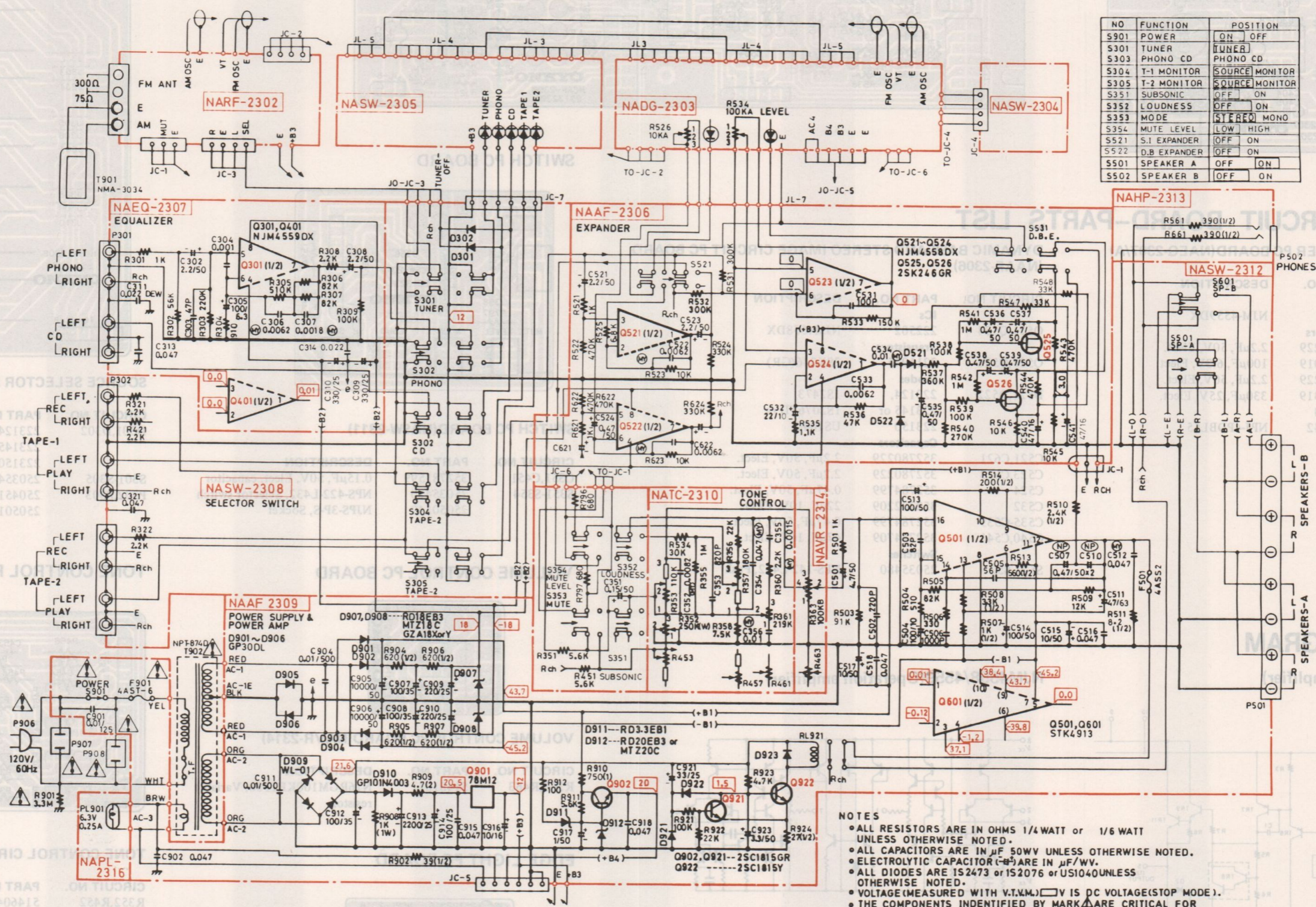

NO	FUNCTION	POSITION
S901	POWER	ON OFF
S301	TUNER	TUNER
S303	PHONO CD	PHONO CD
S304	T-1 MONITOR	SOURCE MONITOR
S305	T-2 MONITOR	SOURCE MONITOR
S351	SUBSONIC	OFF ON
S352	LOUDNESS	OFF ON
S353	MODE	STEREO MONO
S354	MUTE LEVEL	LOW HIGH
S521	S.I EXPANDER	OFF ON
S522	D.B EXPANDER	OFF ON
S501	SPEAKER A	OFF ON
S502	SPEAKER B	OFF ON

- NOTES**
- ALL RESISTORS ARE IN OHMS 1/4 WATT or 1/6 WATT UNLESS OTHERWISE NOTED.
 - ALL CAPACITORS ARE IN μ F 50V UNLESS OTHERWISE NOTED.
 - ELECTROLYTIC CAPACITOR (E) ARE IN μ F/WV.
 - ALL DIODES ARE 1S2473 or 1S2076 or US1040 UNLESS OTHERWISE NOTED.
 - VOLTAGE (MEASURED WITH V.T.M.) \square V IS DC VOLTAGE (STOP MODE).
 - THE COMPONENTS IDENTIFIED BY MARK Δ ARE CRITICAL FOR SAFETY REPLACE ONLY WITH PART NUMBER SPECIFIED.

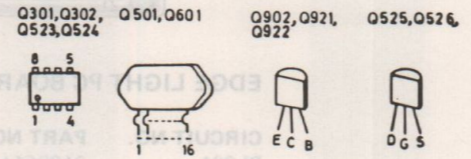

PRINTED CIRCUIT BOARD VIEW FROM BOTTOM SIDE

EQUALIZER AMPLIFIER PC BOARD

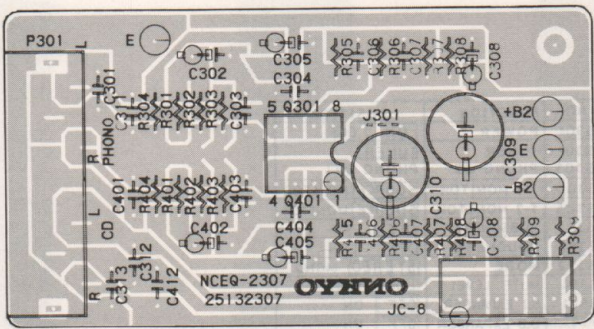

DYNAMIC BASS AND STEREO IMAGE CIRCUIT PC BOARD

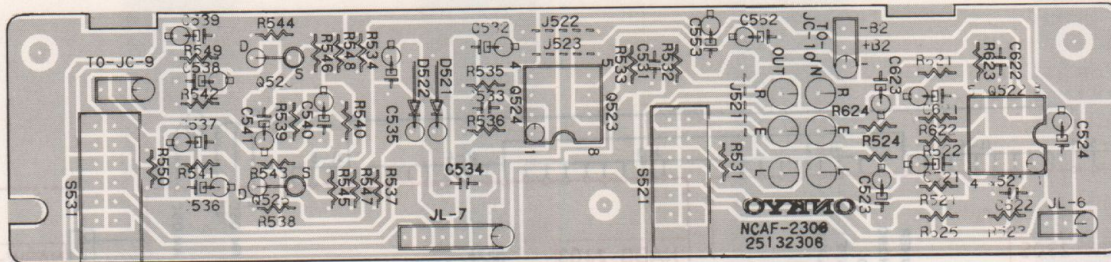

SOURCE SELECTOR SWITCH PC BOARD

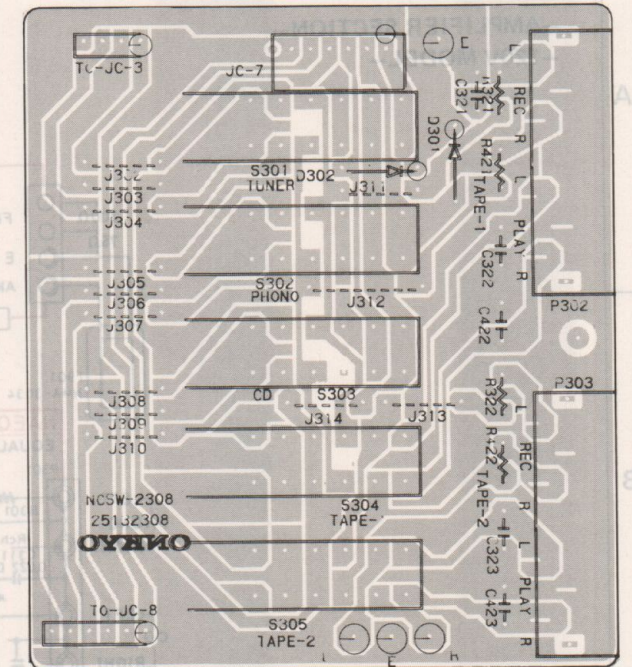

PRINTED CIRCUIT BOARD-PARTS LIST

EQUALIZER AMPLIFIER PC BOARD (NAEQ-2307/A)

CIRCUIT NO.	PART NO.	DESCRIPTION
Q301, Q302	222534	NJM-4559DX IC
		Capacitors
C302, C402	352780229	2.2µF, 50V, Elect.
C305, C405	352721019	100µF, 6.3V, Elect.
C308, C408	352780229	2.2µF, 50V, Elect.
C309, C310	352753319	330µF, 25V, Elect.
		Terminal
P301	25045142	NPJ-4PDBL55

DYNAMIC BASS AND STEREO IMAGE CIRCUIT PC BOARD (NAAF-2306)

CIRCUIT NO.	PART NO.	DESCRIPTION
Q521-Q524	222502	NJM4558DX ICs
Q525, Q526	2211945	2SK246(GR) Transistors
		Diodes
D521, D522	223124,	1S2473,
	223145 or	1S2076TD or
	223150	US1040
		Capacitors
C521, C621	352780229	2.2µF, 50V, Elect.
C523, C623	352780229	2.2µF, 50V, Elect.
C524	352784799	0.47µF, 50V, Elect.
C532	352732209	22µF, 10V, Elect.
C535-C539	352784799	0.47µF, 50V, Elect.
C540, C541	352744709	47µF, 16V, Elect.
		Switches
S521, S531	25035480	NPS-142-L442, Push

SWITCH PC BOARD

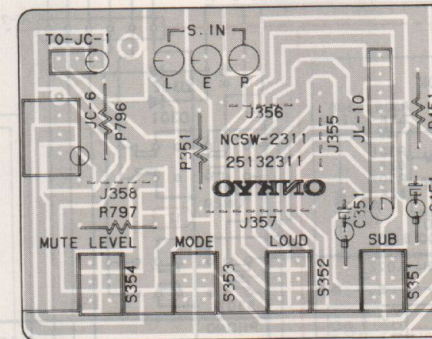

SWITCH PC BOARD (NASW-2311)

CIRCUIT NO.	PART NO.	DESCRIPTION
C351, C451	352781599	0.15µF, 50V, Elect. capacitor
S351-S354	25035470	NPS-422-L432, Selector switch
	25050140	NJPS-3P-S, Socket

SOURCE SELECTOR SWITCH PC BOARD (NASW-2308/A)

CIRCUIT NO.	PART NO.	DESCRIPTION
D301, D302	223124	1S2473,
	223145 or	1S2076TD or
	223150	US1040, Diode
S301-S305	25035468	NPS-542-L430, Push switch
P302, P303	25045142	NPJ-4PDBL55, Tape input/output
	25050143	NJPS-6P-S, Socket, jumper

BLOCK DIAGRAM

STK-4913 (Power amplifier)

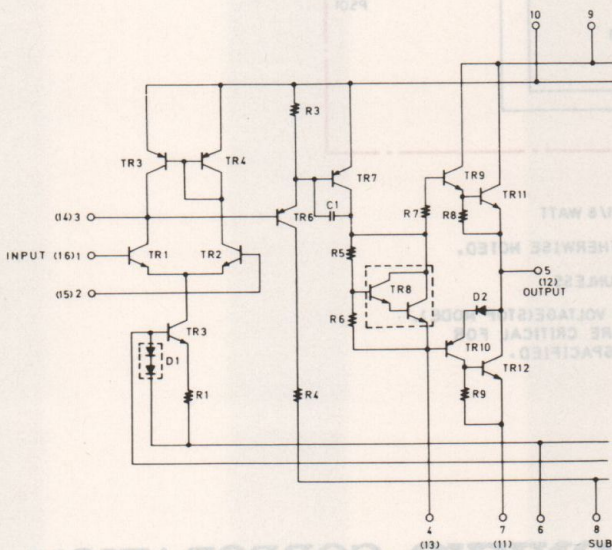

NJM4558/4559 (Operation amplifier)

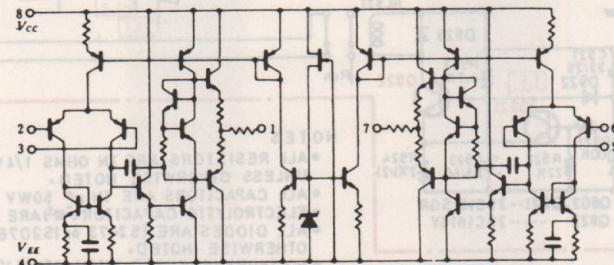

VOLUME CONTROL PC BOARD

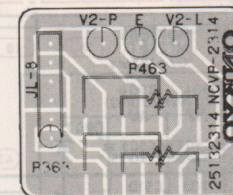

VOLUME CONTROL PC BOARD (NAVR-2314)

CIRCUIT NO.	PART NO.	DESCRIPTION
R363, R463	5148101	N16RGM100KBTP30, Variable resistor

EDGE LIGHT PC BOARD

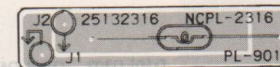

EDGE LIGHT PC BOARD (NAPL-2316)

CIRCUIT NO.	PART NO.	DESCRIPTION
PL901	210064A	PL6.3V, 0.25A, Lamp

TONE CONTROL PC BOARD

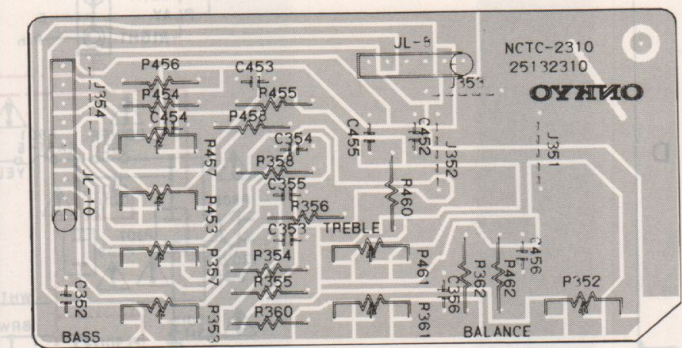

TONE CONTROL CIRCUIT PC BOARD (NATC-2310)

CIRCUIT NO.	PART NO.	DESCRIPTION
R352, R452	5146049	N16RLC250KWT30, Balance control variable resistor
R353, R453	5148073	N16RQMC110K180K30, Bass control variable resistor
R361, R461	5148102	N16RQMC219K30, Treble control variable resistor

SCHEMATIC DIAGRAM

—AMPLIFIER SECTION—
—220V MODEL—

A

B

C

D

E

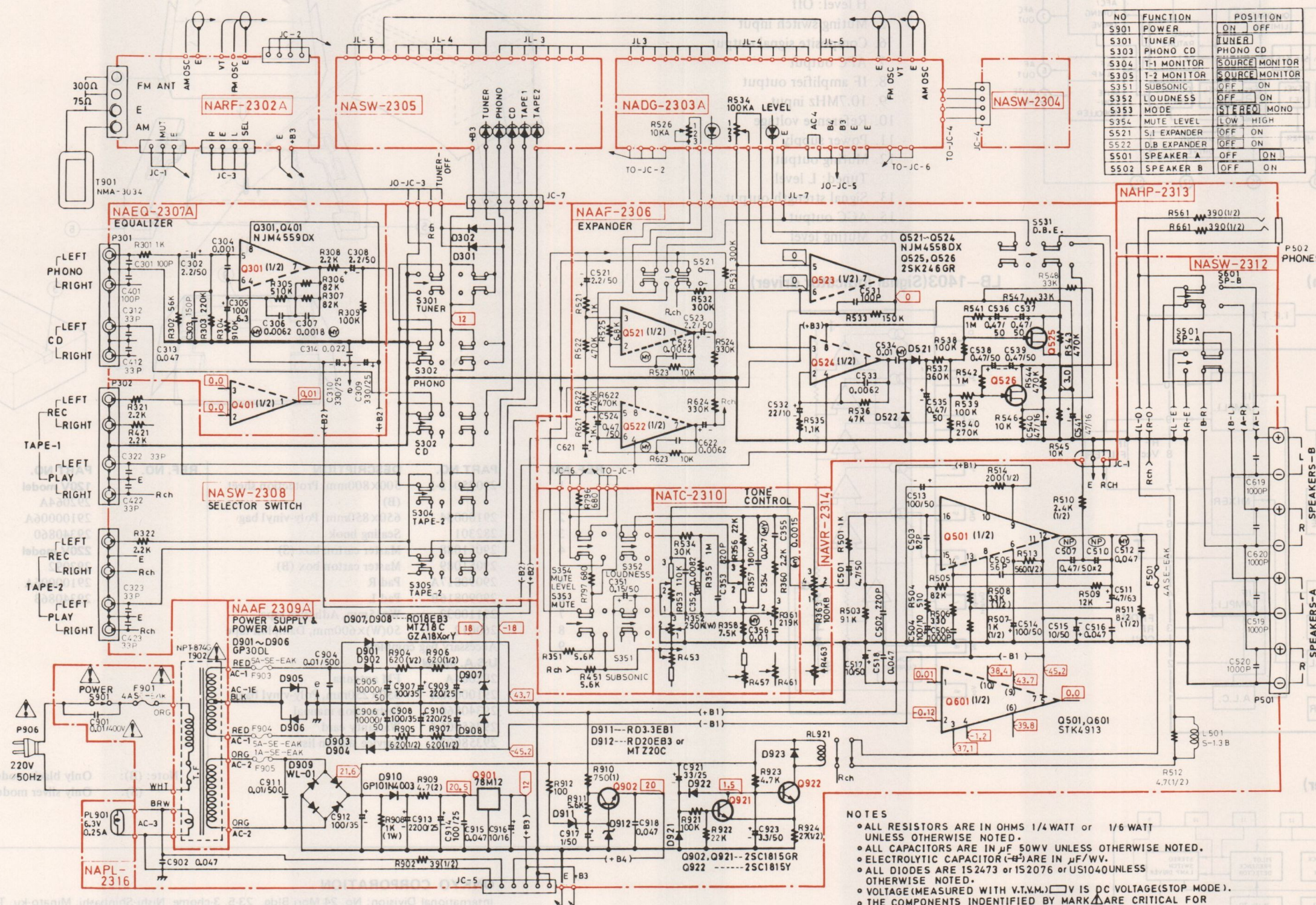

NO	FUNCTION	POSITION
S901	POWER	ON OFF
S301	TUNER	TUNER
S303	PHONO CD	PHONO CD
S304	T-1 MONITOR	SOURCE MONITOR
S305	T-2 MONITOR	SOURCE MONITOR
S351	SUBSONIC	OFF ON
S352	LOUDNESS	OFF ON
S353	MODE	STEREO MONO
S354	MUTE LEVEL	LOW HIGH
S521	S.I EXPANDER	OFF ON
S522	D.B EXPANDER	OFF ON
S501	SPEAKER A	OFF ON
S502	SPEAKER B	OFF ON

NOTES

- ALL RESISTORS ARE IN OHMS 1/4 WATT or 1/6 WATT UNLESS OTHERWISE NOTED.
- ALL CAPACITORS ARE IN μ F 50V UNLESS OTHERWISE NOTED.
- ELECTROLYTIC CAPACITOR (-E) ARE IN μ F/WV.
- ALL DIODES ARE 1S2473 or 1S2076 or US1040 UNLESS OTHERWISE NOTED.
- VOLTAGE (MEASURED WITH V.T.M.) \square IS DC VOLTAGE (STOP MODE).
- THE COMPONENTS IDENTIFIED BY MARK Δ ARE CRITICAL FOR SAFETY. REPLACE ONLY WITH PART NUMBER SPECIFIED.

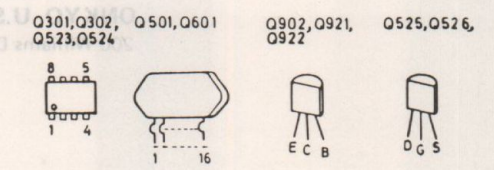

BLOCK DIAGRAM OF IC

HA-11225(FM IF system)

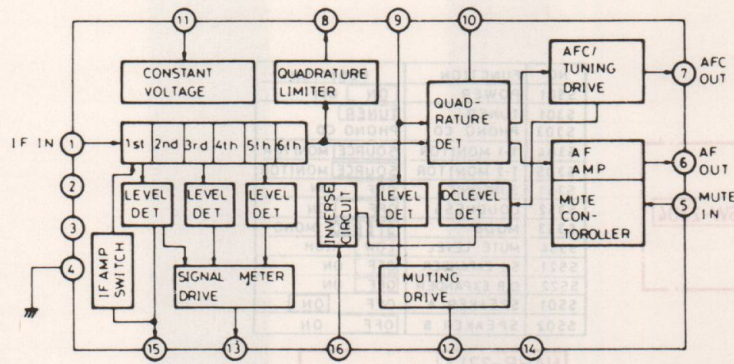

1. IF signal input
2. IF amplifier switch input
H level: Off
5. Muting switch input
6. Composite signal output
7. AFC output
8. IF amplifier output
9. 10.7MHz input
10. Reference voltage
11. Power supply
12. Muting output
Tuned: L level
13. Signal strength output
15. AGC output
16. Muting level

PACKING VIEW

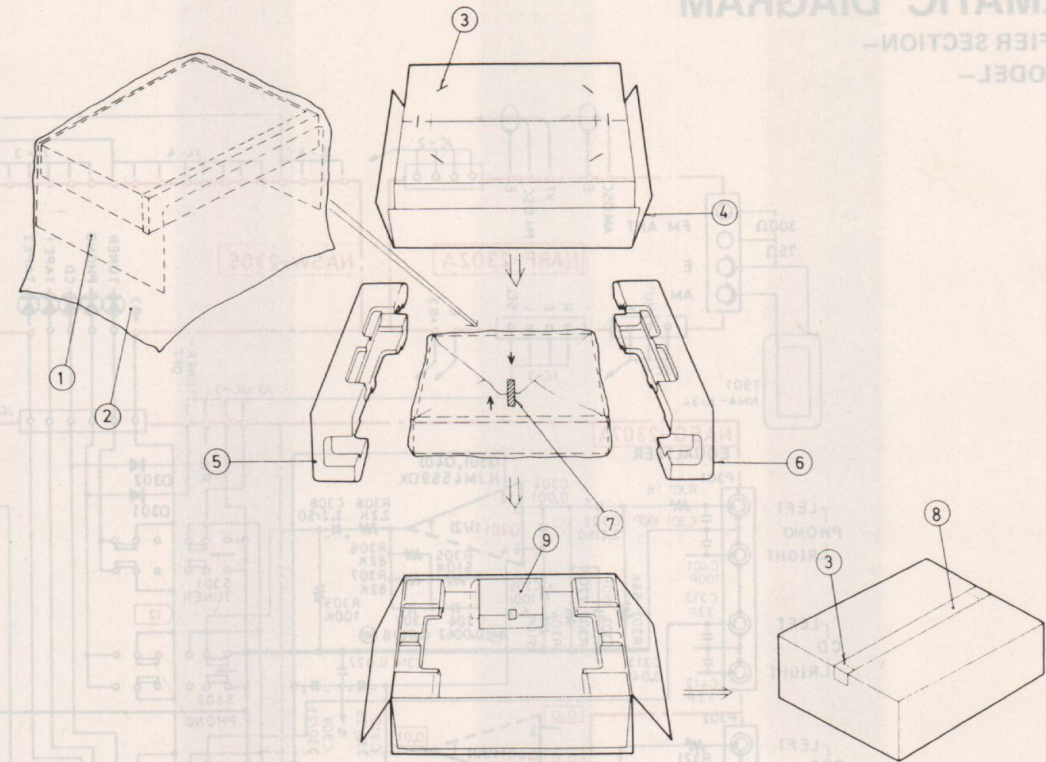

LA-1245(AM radio system)

LB-1403(Signal indicator driver)

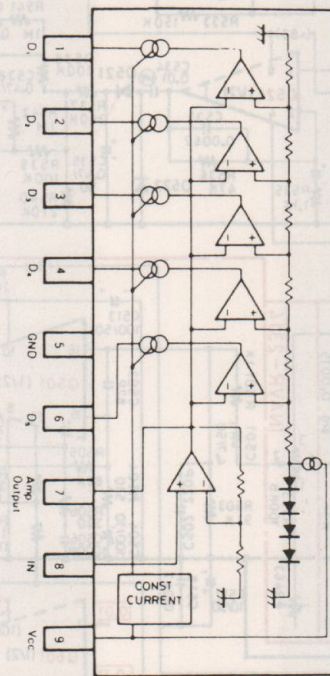
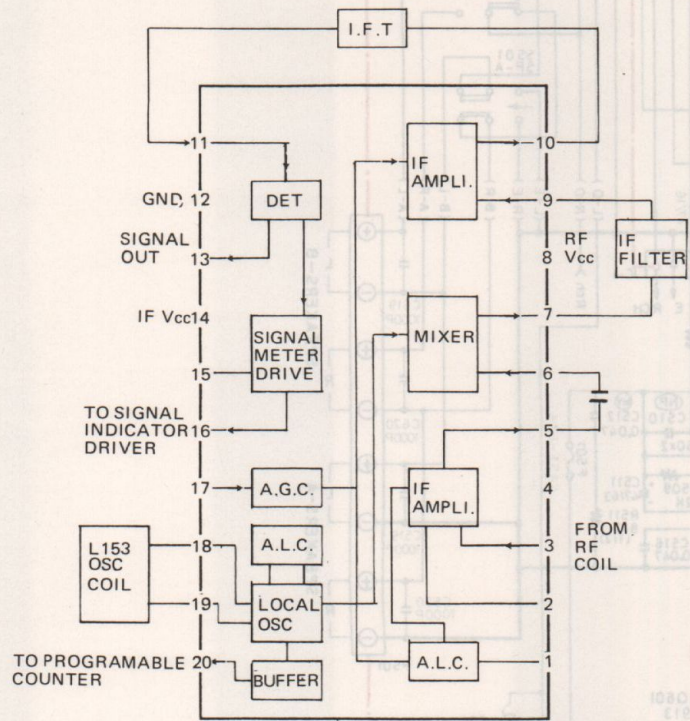

REF. NO.	PART NO.	DESCRIPTION	REF. NO.	PART NO.	DESCRIPTION
1	29095012-1	500x800mm, Protection sheet (B)	1	120V model 292064A	FM antenna
2	29100034	650x850mm, Poly-vinyl bag	2	29100006A	350x250mm, Poly-vinyl bag
3	282301	Sealing hook	3	29340860	Instruction manual
4	29051088	Master carton box (S)	4	220V model 292092	FM antenna
5	29051089	Master carton box (B)	5	29100006A	350x250mm, Poly-vinyl bag
6	29090817A	Pad R	6	29340863	Instruction manual
7	29090816B	Pad L			
8	29110032	W=15mm, Adhesive tape			
9	260012	50(W)x600mm, Dampion tape			
		Accessory bag complete			
	U.S.A. model				
	292064A	FM antenna			
	29100006A	350x250mm, Poly-vinyl bag			
	29340860	Instruction manual			
	29365006-6	Warranty card			
	29358002C	Service station list			

Note: (B): Only black model
(S): Only silver model

μPC1161C3(Stereo decoder)

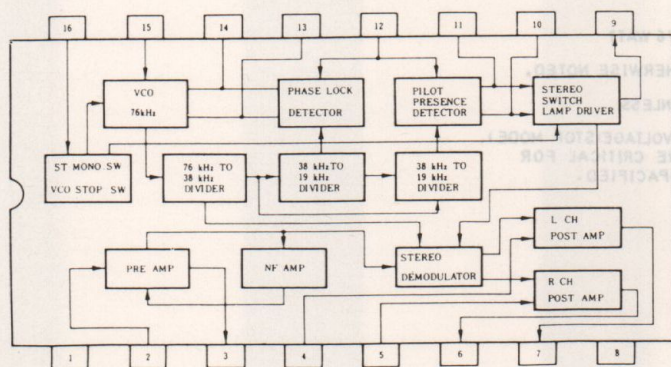

ONKYO CORPORATION

International Division: No. 24 Mori Bldg., 23-5, 3-chome, Nishi-Shinbashi, Minato-ku, Tokyo, Japan
Telex: 2423551 ONKYO J. Phone: 03-432-6981

ONKYO U.S.A. CORPORATION

200 Williams Drive, Ramsey, N.J. 07446 Tel. 201-825-7950