

# ONKYO® SERVICE MANUAL

## QUARTZ SYNTHESIZED TUNER AMPLIFIER

### MODEL TX-61

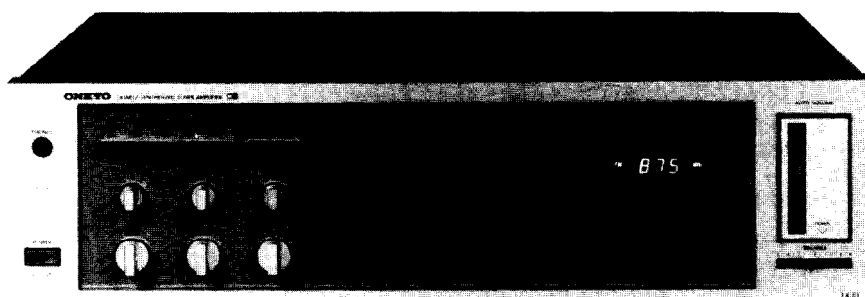

#### TABLE OF CONTENTS

Item	Page
Specifications	2
Precautions	3
Block diagram	4
Component location	7
Exploded view	8
Parts list	10
Adjustment procedures	11
Pc board view/parts list	15
Digital circuit	15
Tuner circuit	21
Preamplifier circuit	25
Auto. volume circuit	29
CX decoder circuit	30
Voltage regulator	32
Main amplifier	33
Schematic diagram	37
Packing view	41

**ONKYO®**  
**AUDIO COMPONENTS**

## SPECIFICATIONS

### AMPLIFIER SECTION

Output Power:	60 watts per channel, min RMS at 8 ohms, both channels driven, from 20Hz to 20,000Hz with no more than 0.025% total harmonic distortion
Total Harmonic Distortion:	0.025% at rated power 0.025% at 1 watt output
IM Distortion:	0.025% at rated power 0.025% at 1 watt output
Damping Factor:	50 at 8 ohms
Frequency Response:	20Hz—30,000Hz ( $\pm 1$ dB)
RIAA Deviation:	20Hz—20,000Hz ( $\pm 0.5$ dB)
Sensitivity & Impedance:	Phono: (MM) 2.5mV, 50 kohms (MC) 350 $\mu$ V, 330 ohms Tape Play: 150mV, 50 kohms Tape Rec: 150mV, 3.5 kohms (PH) 200mV R.M.S. at 1kHz 0.025% T.H.D.
Phono Overload:	
Signal-to-Noise Ratio:	Phono: 86dB (at 10mV input (MM) A weighted) 76dB (IHF A-202) Tape: 95dB (A weighted) 80dB (IHF A-202)
Tone Controls:	Bass: $\pm 12$ dB at 100Hz Treble: $\pm 10$ dB at 10kHz
Filters:	High: 6kHz, 6dB/oct. Subsonic: 15Hz, 6dB/oct
Loudness (-30dB):	$\pm 9$ dB at 40Hz $\pm 5$ dB at 20kHz

### TUNER SECTION

#### FM:

Tuning Range:	87.5—108MHz (100kHz steps) (D model) 87.5—108MHz (50kHz steps) (W model)
Usable Sensitivity:	Mono: 10.3dBf, 1.8 $\mu$ V Stereo: 17.2dBf, 4.0 $\mu$ V
50dB Quieting Sensitivity:	Mono: 14.7dBf, 3.0 $\mu$ V Stereo: 37.2dBf, 40 $\mu$ V
Capture Ratio:	1.3dB
Image Rejection Ratio:	80dB
IF Rejection Ratio:	90dB
Spurious Rejection Ratio:	90dB
Signal-to-Noise Ratio:	Mono: 75dB Stereo: 70dB
Alternate Channel Att.:	70dB
AM Suppression Ratio:	55dB
Harmonic Distortion:	Mono: 0.12% Stereo: 0.2%
Frequency Response:	30Hz—15,000Hz ( $\pm 1.5$ dB)
Stereo Separation:	40dB at 1kHz 33dB at 100Hz—10,000Hz
Muting level:	17.2dBf, 4 $\mu$ V
Stereo Threshold:	17.2dBf, 4 $\mu$ V

#### AM:

Tuning Range:	520—1,710kHz (10kHz steps) (D model) 520—1710kHz (10kHz steps) or 522—1611kHz (9kHz steps) (W model)
Usable Sensitivity:	30 $\mu$ V
Image Rejection Ratio:	40dB
IF Rejection Ratio:	30dB
Signal-to-Noise Ratio:	40dB
Harmonic Distortion:	0.8%

### GENERAL

Power Supply:	AC 120V, 60Hz (D model) AC 120/220V, 50/60Hz (W model)
Outputs:	Speaker A & B, Phones, Tape Rec. Out 1 & 2, EPS OUT/PRE OUT, AC Outlet (D model) (unswitched x 1, switched x 1)
Inputs:	Phono, Tape Play 1 & 2, EPS IN/MAIN IN
Antennas:	FM and AM Antennas FM: 300 ohms balanced and 75 ohms unbalanced AM: built-in loop antenna and external terminal
Semiconductors:	6FET, 56 transistors, 231Cs, 102 diodes (D model) 6FET, 59 transistors 231Cs, 105 diodes (W model)
Dimensions (W x H x D)	500 x 141 x 450 mm 19-11/16" x 5-9/16" x 17-3/4"
Weight:	13.0kg, 28.6lbs.

Specifications and features are subject to change without notice.

17-3/4"

res.

to change without notice

## PRECAUTIONS

### 1. Replacing the fuses

Remove the top cover. The primary fuses are located on the fuse terminal pc board as shown in the fig. 1.

Caution: For continued protection against fire hazard, replace only with same type and same rating fuse.

	Circuit No.	Parts No.	Description	Remarks
Primary fuse	F901	252050	5A (ST-6)	120V model
	F902	252075	2.5A-SE-EAK	120/220V model
	F901	252020	5A-T	120/220V model

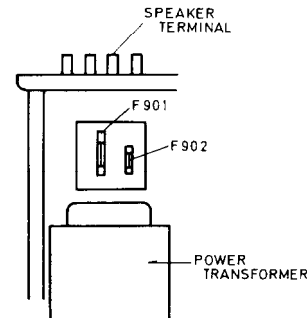

Fig. 1

### 2. Replacing the MOS IC

1. All MOS devices should be stored or transported in materials that are somewhat conductive. MOS devices must not be inserted into conventional plastic "snow" or plastic trays.
2. All MOS devices should be placed on a grounded bench surface and operators should ground themselves prior to handling devices, since a worker can be statically charged with respect to the bench surface.

3. Nylon clothing should not be worn while handling MOS circuits.
4. When lead straightening or hand soldering is necessary, provide ground straps for the apparatus used.
5. Double check test equipment setup for proper polarity of voltage before conducting parametric or functional testing.
6. All unused device inputs should be connected to  $V_{DD}$  or  $V_{SS}$ .

## SPECIAL MODES OPERATION

### 1. Memory Preservation Batteries

Because stations stored in the memory by the FM/AM preset keys would normally be lost when power is turned off or the plug removed from the wall socket, this unit requires two memory preservation batteries to preserve the

contents of the memory even when power is turned off. Be sure to insert the correct type of two batteries into the battery holder in the bottom of the unit before turning on power for the first time.

Type	Voltage (V)	IEC	United States									United Kingdom		West Germany	France	Denmark	Italy	Australia
			ANSI	NEDA	Eveready	Mallory	Ray-O-Vac	Bright Star	Burgess	RCA	Sears	Eveready (BEREC)	Mallory	VARTA (Pertrix)	S A F T (Leclanche)	Hellesens	Supper Pila	Eveready
Manganese	1.5	R6	AA	15P	815	M15P	710	59P	920	VS734	8950				R6S	VI 18	63	
				15F	915	M15F	7AA	59	910	VS034A		SP12		251	R6B	VI 28		915
				15	1015	M150F	15	0199	930	VS334		SP12		244	T3S	VI 38		1015
				15D	1215	M1504	5AA					HP7		280		VI 75		

### 2. De-emphasis Switch (Only W model)

The  $50\mu\text{sec}/75\mu\text{sec}$  selector switch employed in the W (120/220V) model is located on the bottom board. When shipped from the factory, this switch is set to the  $50\mu\text{sec}$  position. For use  $75\mu\text{sec}$  regions, switch over to the  $75\mu\text{sec}$  position.

### 3. Voltage Selector (Only W model)

Some models are equipped with a voltage selector to conform with local power supplies.

Be sure to set this switch to match the voltage of the power supply in your area before turning the power switch on.

# BLOCK DIAGRAM —AMPLIFIER SECTION—

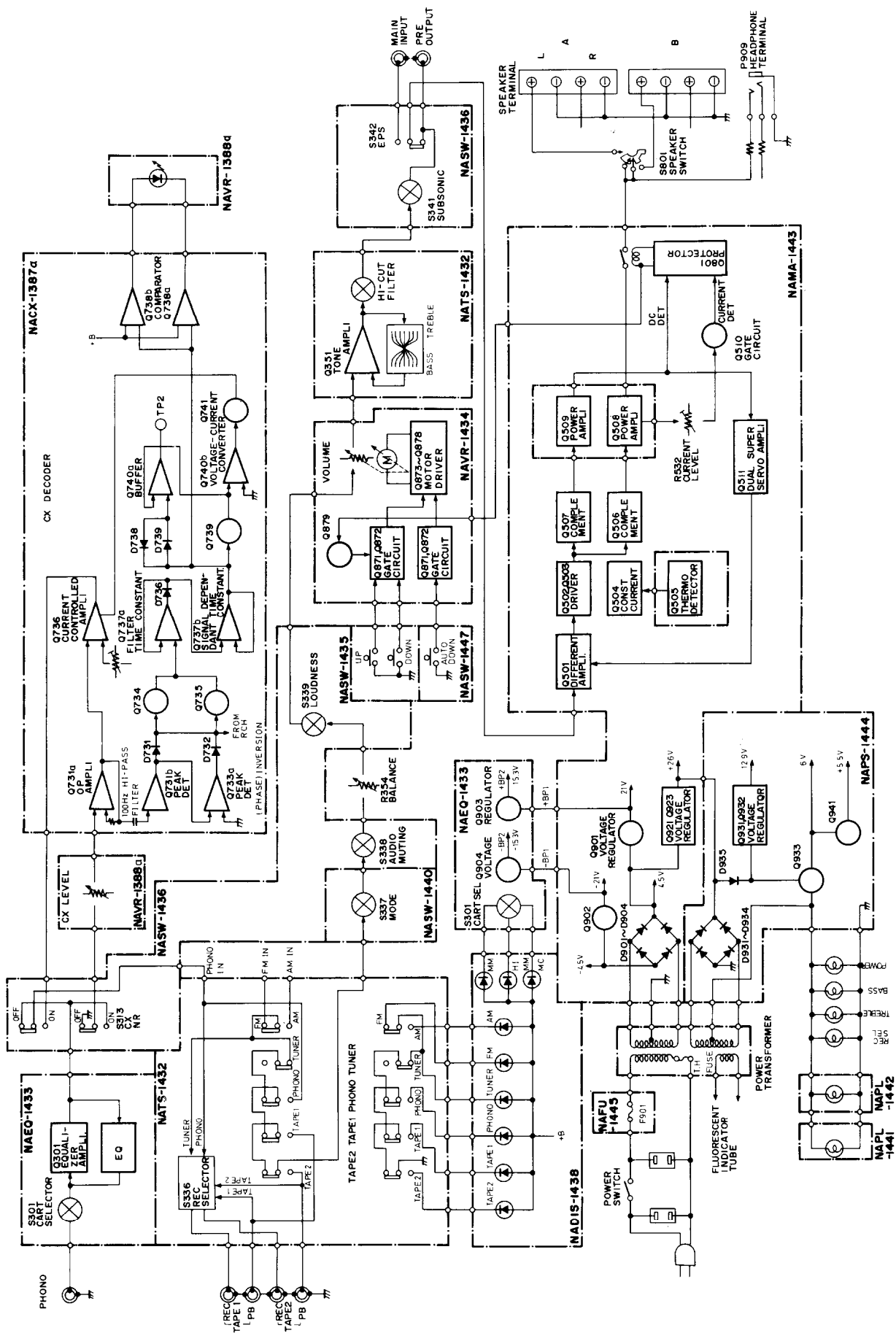

Fig. 2

**BLOCK DIAGRAM**  
**— TUNER SECTION —**  
**D model**

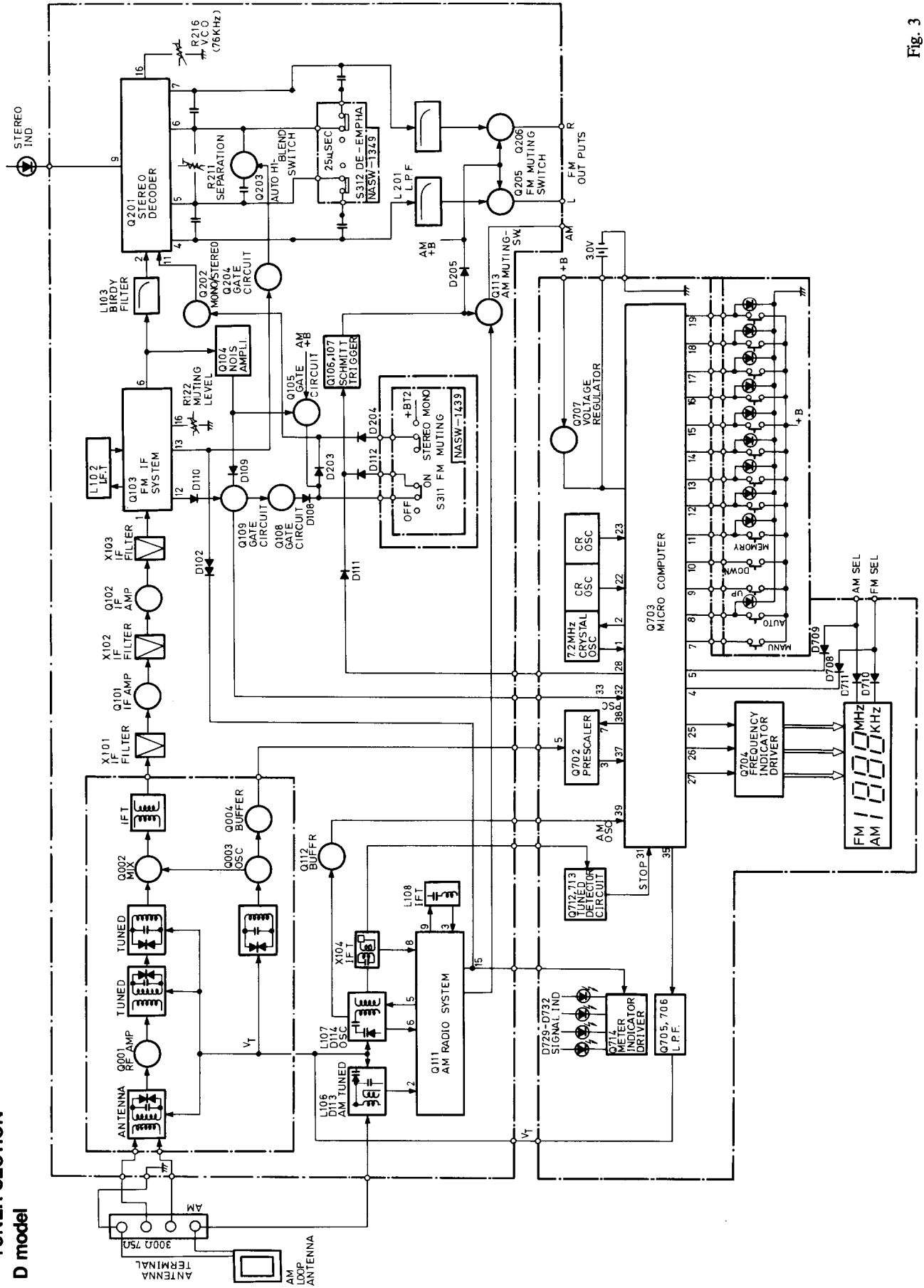

Fig. 3

# BLOCK DIAGRAM

## —TUNER SECTION—

### W model

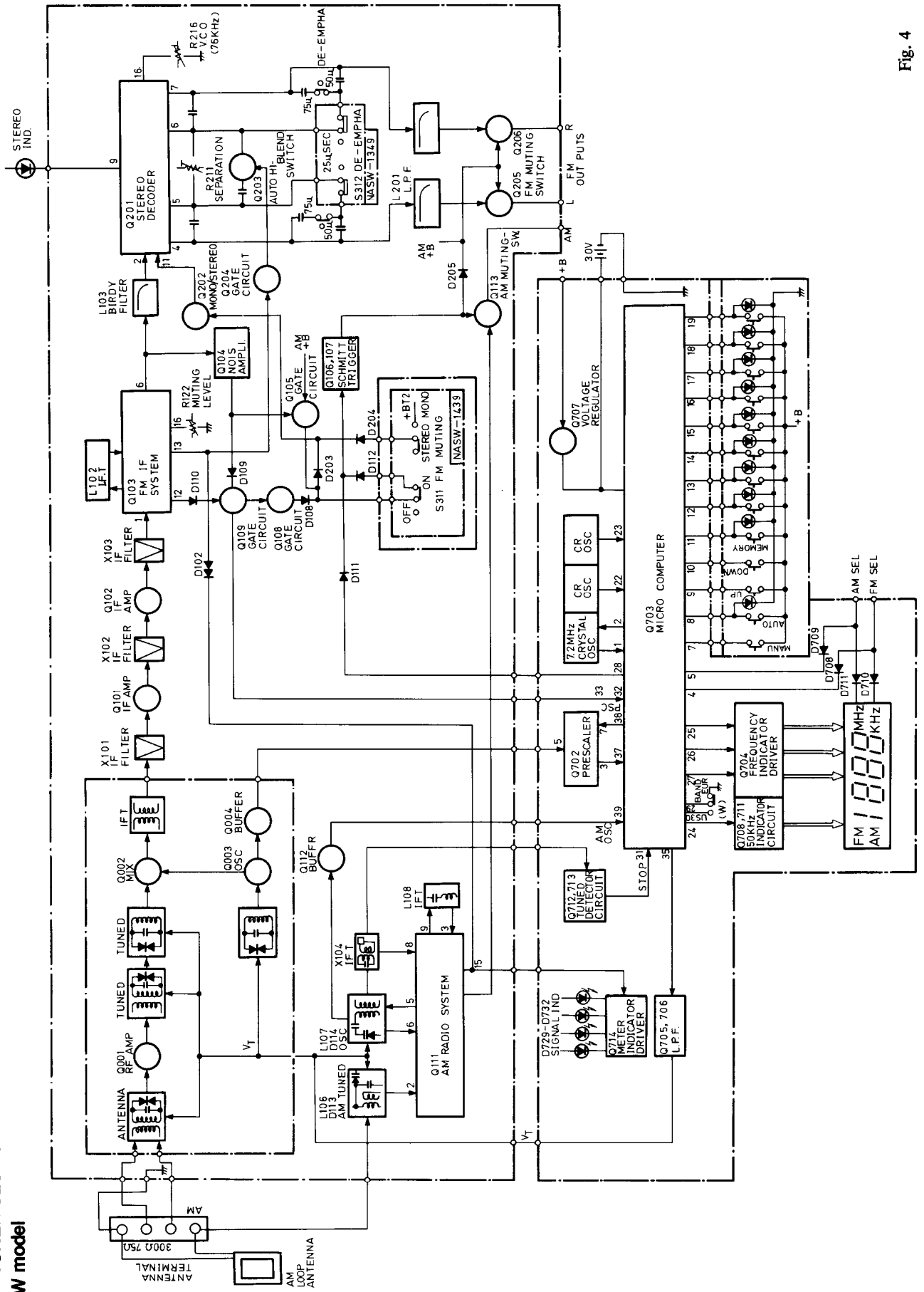
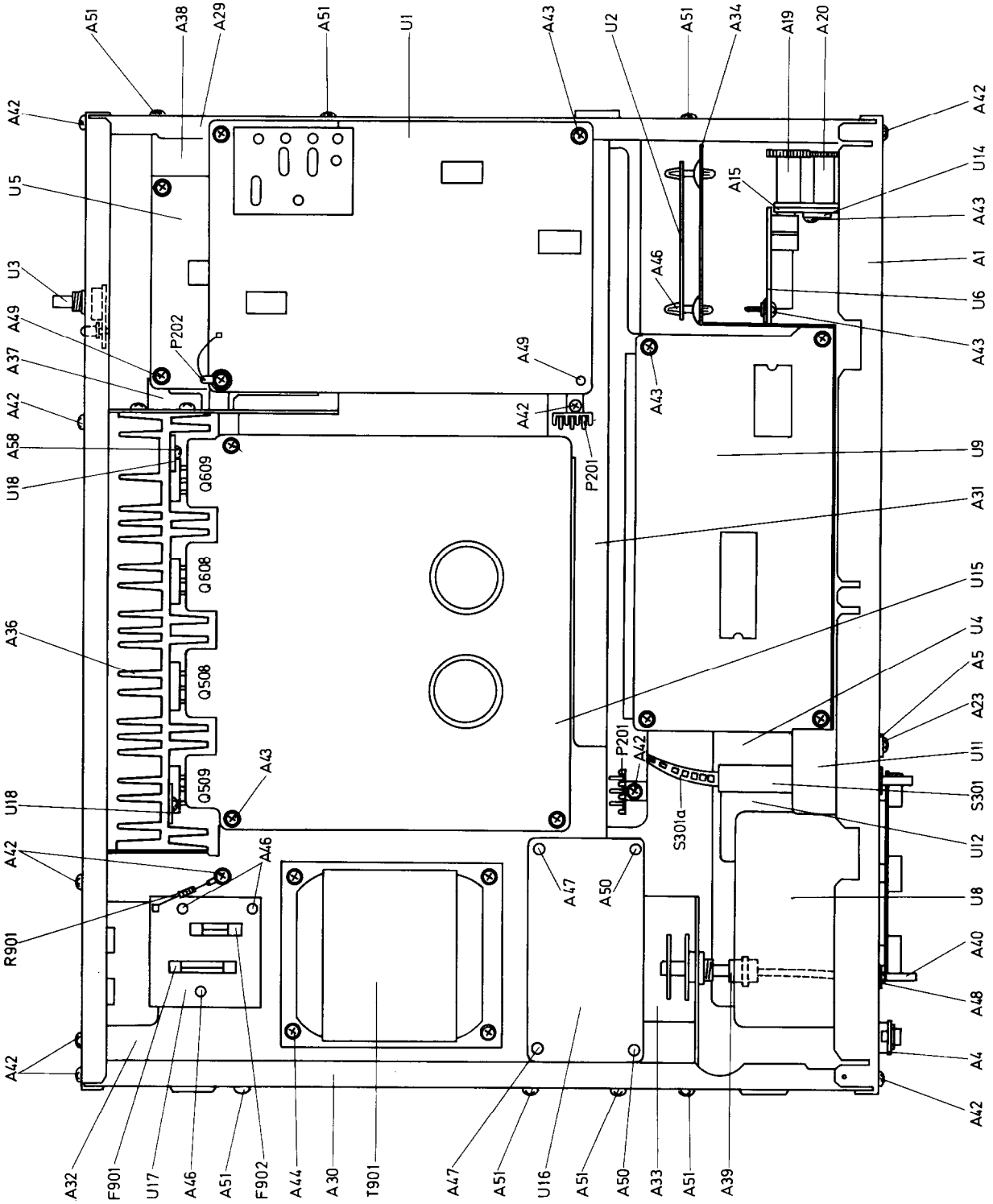

Fig. 4

Fig. 5

COMPONENT LOCATION



**EXPLODED VIEW**

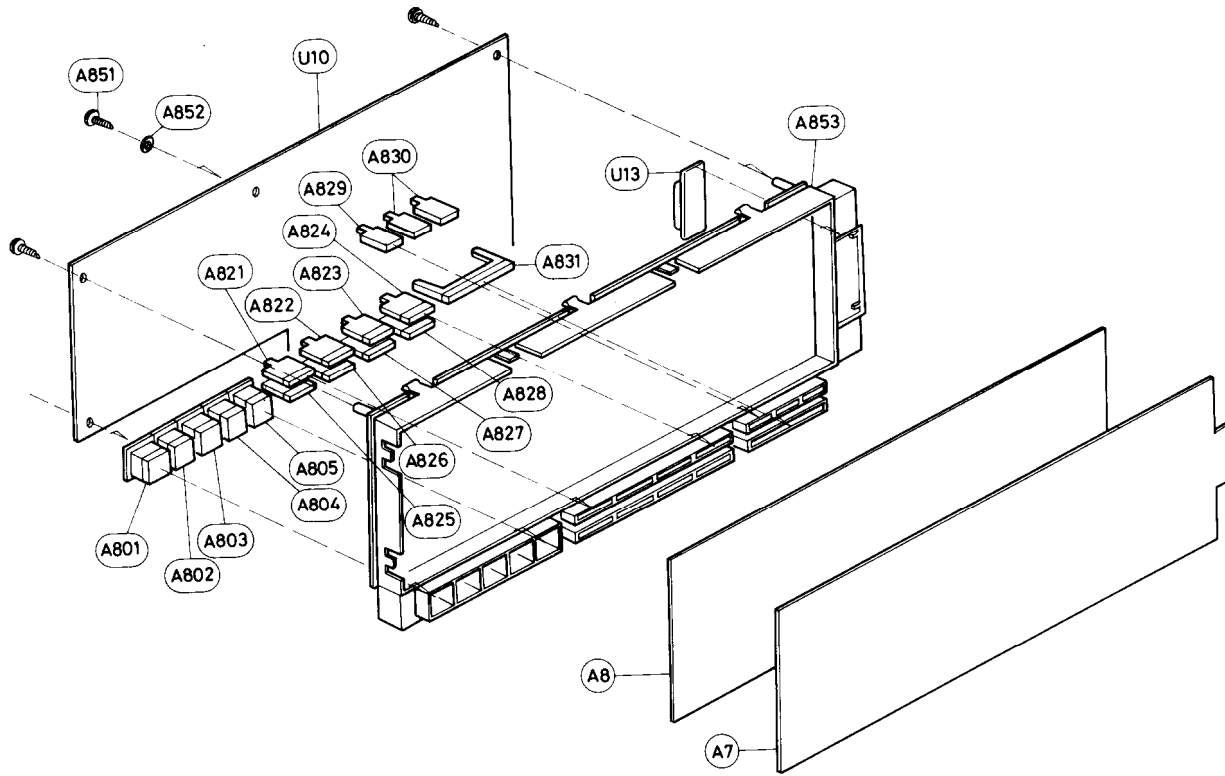

Fig. 6

**Holder view**

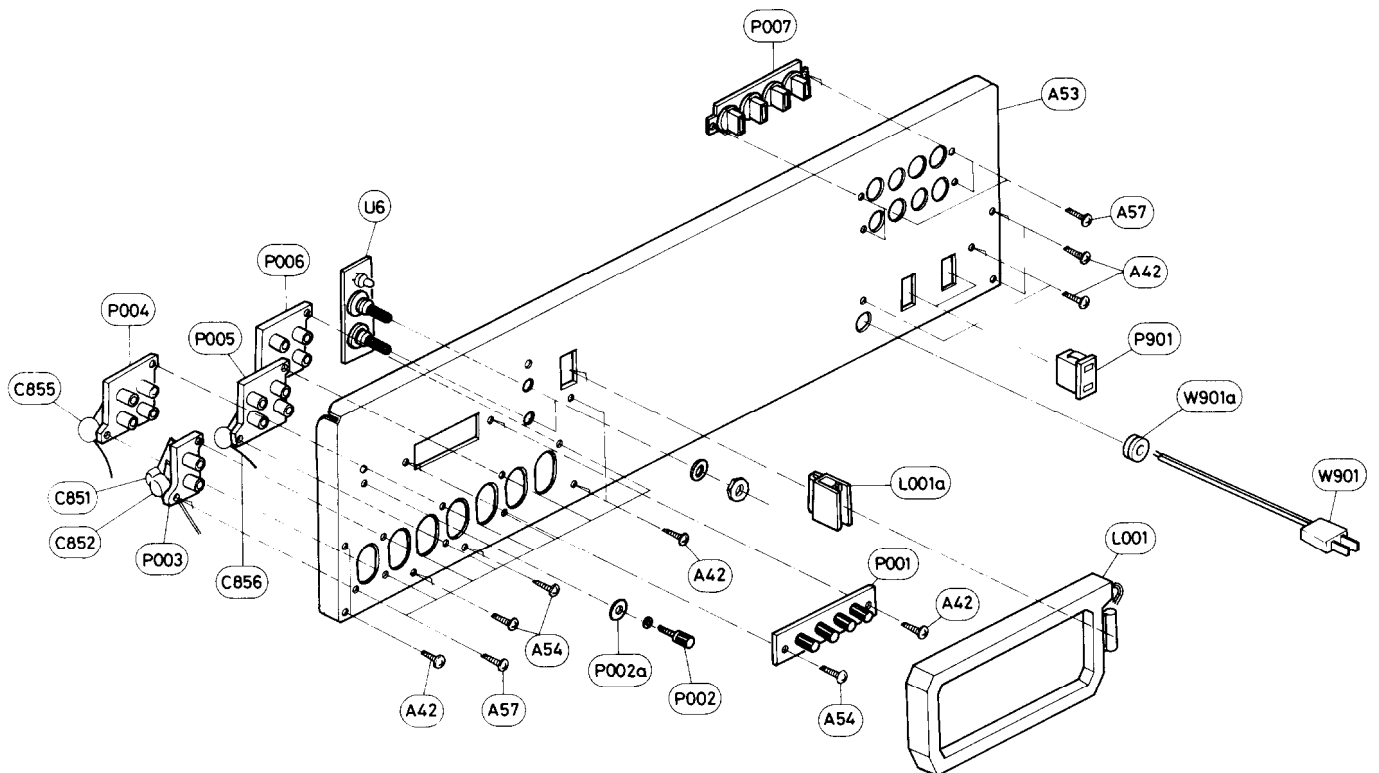

Fig. 7

**Back panel view**





## PARTS LIST

REF. NO.	PARTS NO.	DESCRIPTION	REF. NO.	PARTS NO.	DESCRIPTION
A1	27110173A	Front bracket	A803	28320776	Knob, PHONO
A3	27140676A	Bracket, lamp	A804	28320777	Knob, TUNER
A4	27140679	Bracket, headphone	A805	28320778	Knob, FM
A5	27140678	Bracket, left	A806	28320760	Knob, power
A6	27140680	Bracket, pc	A807	28320772	Knob, mode
A7	28130154B	Dial plate	A808	28320800	Knob, speaker
A8	28133064A	Back plate	A809	28320802A	Knob, tone
A9	27300503	Collar	A810	28320803A	Knob, selector
A10	27300442	Bush	A811	28320801A	Knob
A11	28140020	4x10x40mm, Cushion	A812	28320799	Knob, volume
A15	29105115	Case ass'y	A813	28320804	Knob, balance
A19	27300473	Gear, volume	A814	28320805	Knob, auto
A21	831130168	3TTW + 16B, Tapping screw	A801	28320811	Knob, station 1
A22	833130080	3TTP + 8P, Tapping screw	A822	28320812	Knob, station 2
A23	834130068	3TTS + 6B, Tapping screw	A823	28320813	Knob, station 3
A24	82113006	3P + 6FN, Pan head screw	A824	28320814	Knob, station 4
A25	82112003	2P + 3FN, Pan head screw	A825	28320815	Knob, station 5
A27	27300360	Case, battery	A826	28320816	Knob, station 6
A28	27140463	Bracket, battery	A827	28320817	Knob, station 7
A29	27115121A	Side bracket, right	A828	28320818	Knob, station 8
A30	27115122	Side bracket, left	A829	28320809	Knob, red
A31	27130315	Bracket, center	A830	28320808	Knob, memory
A32	27130316A	Bracket, power transformer	A831	28320779	Knob, tuning
A33	27140674	Bracket, speaker	A851	833130080	3TTB + 8P, Tapping screw
A34	27130317A	Bracket, auto	A852	870048	W3x8x0.8mm, Nylon washer
A36	27160107	Heatsink	C851, C852	379124737	0.047 $\mu$ F, 50V, Capacitor, DEW
A37	27140673	Bracket, heatsink	C855, C856	330924730	0.047 $\mu$ F, 50V, Capacitor, ceramic
A38	27140675	Bracket, equalizer	C901	3500065A	0.01 $\mu$ F, 400V, Capacitor IS
A39	27273008	Joint, speaker	C901a	27300080	Cover, capacitor
A40	27260086	Shaft, speaker	F901	252050	5A (ST-6), Primary fuse (D)
A42	834130068	3TTS + 6B, Tapping screw	F901	252020	5A—T, Primary fuse (W)
A43	831130088	3TTW + 8B, Tapping screw	F902	252075	2.5A-EA-EAK, Primary fuse (W)
A44	838440089	4TTW + 8C (BC), Tapping screw	L001	232098	NMA-3040, AM loop antenna
A45	834130108	3TTS + 10B, Tapping screw	L001a	27190129	Holder, AM loop antenna
A46	27190011	Holder	P001	25060035	NTM-4TRMC06, Antenna terminal
A47	27190164	Holder	P002	25060044	Ground terminal
A48	27140184	Bracket, shaft	P002a	87613010	W3x10F, Flat washer
A49	27190062	Holder	P003	25045047	NPJ-2PRBL22, Terminal, PHONO
A50	27190009	Holder	P004-P006	25045025	NPJ-4PRBL03, Terminal, Tape1/2 and EPS
A51	838130068	3TTB + 6B, Tapping screw	P007, P008	25060049	NTM-4PRMN18, Speaker terminal
A52	27175011C	Leg	P009	25045067	HLJ-0279-01-070, Stereo headphone
A53	27120418	Back panel (D)	P201	26060025	T5251-B, Ground terminal
	27120419	Back panel (W)	P202	223004-1	Terminal
A54	834230108	3TTS + 10B (NI), Tapping screw		26065203	Binder
A56	834130068	3TTS + 6B, Tapping screw	P901, P902	25050046	NSCT-2P15, AC outlet (D)
A57	834130108	3TTS + 10B, Tapping screw	PL803-PL805	210109	PL14V0.06AW4.0, Lamp, Rec/Treble/Bass
A58	834130088	3TTS + 8B, Tapping screw	PL806	210096	PL14V0.08AW-2, Power indicator lamp
A301	28184149A	Top cover	Q508, Q608	2201103 or 2201102	2SD845 (O) or 2SD845 (R), Power amplifier transistor
A302	838440089	4TTB + 8C (BC), Tapping screw	Q509, Q609	2201093 or 2201092	2SB755 (O) or 2SB755 (R), Power amplifier transistor
A303	834130068	3TTS + 6B, Tapping screw	R354, R454	6142011	N30LGC100KMN15Z, Balance control variable resistor
A304	28140020	4x10x40mm, Cushion	R551, R651	441623314	330 $\Omega$ , 1W, Metal oxide film resistor
A501	13258121	Front panel ass'y	R901	431523355	3.3M $\Omega$ , 1/2W, Solid resistor
A502	28125077-2	End cap	S301	25030221	NRSM-103-25ZV, Cartridge selector switch
A503	28191142	Clear plate	S301a	25065210	Wire, remote switch
A504	27267179	Guide, power	S801	26030222	NRS-124-50Y, Speaker selector switch
A505	28198574-1	Facet	S901	25035135 or 25035321	NPS-111-L100P or NPS-111-L285P, Power switch (D)
A506	27267199	Guide, volume	S901	25035176 or 25035322	NPS-111-L140 or NPS-111-L286P, Power switch (W)
A507	28140425	Cushion	S902	25065123	NSS-1258P, Voltage selector switch (W)
A508	28130155	Plate, volume		250142	NSS-2225, Band selector switch
A509	28199064B	Film	T901	230622	NPT-783D, Power transformer (D)
A510	27180136	Spring			
A511	27267200	Guide, mode			
A512	27140681	Bracket, auto			
A513	880009	Rivert			
A516	835130065	3STF + 6B, Tapping screw			
A631	27170133	Bottom board			
A632	27175009A	Leg			
A633	831130068	3TTW + 6B, Tapping screw			
A634	834130128	3TTS + 12B, Tapping screw			
A635	27300359	Lid			
A521	27180147	Spring			
A801	28320774	Knob, TAPE2			
A802	28320775	Knob, TAPE1			

REF. NO.	PARTS NO.	DESCRIPTION	REF. NO.	PARTS NO.	DESCRIPTION
T901	230623	NPT-783DG, Power transformer (W)	U12	13258540	NASW-1440, Mode switch pc board ass'y
U1	13258574D	NARF-1374d, FM/AM tuner pc board ass'y (D)	U13	13258541	NAPL-1441, Dial illumination lamp pc board ass'y
	13260574E	NARF-1374e, FM/AM tuner pc board ass'y (W)	U14	13258542	NAPL-1442, Volume illumination lamp pc board ass'y
U2	13258587A	NACX-1387a, CX decoder pc board ass'y	U15	13258543	NAMA-1443, Power amplifier, protector and power supply pc board ass'y (D)
U3	13258588A	NAVR-1388a, CX level pc board ass'y	U15	13260543A	NAMA-1443a, Power, protector and power supply pc board ass'y (W)
U4	13258532	NATS-1432, Tone control and switch circuit pc board ass'y	U16	13258544	NAPS-1444, Power supply circuit pc board ass'y
U5	13258533	NAEQ-1433, Equalizer amplifier pc board ass'y	U17	13258545	NAFU-1445, Fuse terminal pc board ass'y
U6	13258534	NAVR-1434, Auto volume circuit pc board ass'y		13260545A	NAFU-1445a, Fuse terminal pc board ass'y
U7	13258535	NASW-1435, UP/DOWN switch pc board ass'y	U18	13258546	NACC-1446, Thermal detector pc board ass'y
U8	13258536	NASW-1436, Operation switch pc board ass'y	U19	13258547	NASW-1447, Auto down switch pc board ass'y
U9	13258537	NADG-1437, Digital circuit pc board ass'y (D)	W901	253112	AS-UC-4, Power supply cable (D)
	13260537A	NADG-1437a, Digital circuit pc board ass'y (W)	W901a	253092	AS-CEE, Power supply cable (W)
U10	13258538	NADIS-1438, Display pc board ass'y (D)		270280	SR-4K-4, Strainrelief
	13260538A	NADIS-1438a, Display pc board ass'y (W)			
U11	13258539	NASW-1439, Muting switch pc board ass'y			

Note: (D) : Only 120V model  
(W) : Only 120/220V model

## ADJUSTMENT PROCEDURES

### INSTRUMENTS REQUIRED

1. DC Voltmeter
2. AM Sweep Generator
3. AM/FM Signal Generator
4. AC VTVM
5. Oscilloscope
7. Distortion Analyzer
8. Stereo Modulator
9. Frequency Counter

#### 1. +B2 Voltage Adjustment (Only W model)

Connect the DC voltmeter between the + BT1 and E terminals on the power amplifier pc board. Adjust the semi-fixed resistor R929 so that the indication of voltmeter become 25.3V.

### GENERAL ALIGNMENT CONDITIONS

1. Signal input should be kept as low as possible.
2. Standard modulation is 400Hz 30% (AM), 1kHz 100% (FM MONO), pilot 9% sub and main 91% (FM STEREO).
3. Standard knob position  
 SPEAKERS . . . . . A  
 BASS, TERBLE & BALANCE . . . . . Center  
 MODE . . . . . STEREO  
 LOUNDNNESS . . . . . OFF  
 TAPE 1, 2 . . . . . OFF (SOURCE)

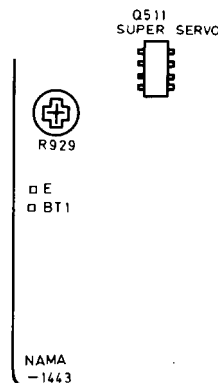
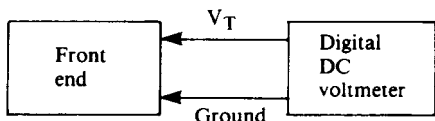

Fig. 9

2. Front end adjustment



Step	Set to dial	Adjust	Output indicator	Adjust for
FM adjustment				
1	88.1 MHz	L008 (LO)	Digital DC voltmeter	3.03V
2	107.9MHz	TC004 (TCO)		20.8V
3	Repeat steps 1 and 2 as necessary			
AM adjustment				
1	600 kHz (603 kHz)	L107	Digital DC voltmeter	2.5V
2	1400 kHz (1404 kHz)	C156		15.5V
3	Repeat steps 1 and 2 as necessary			

( ) : W model

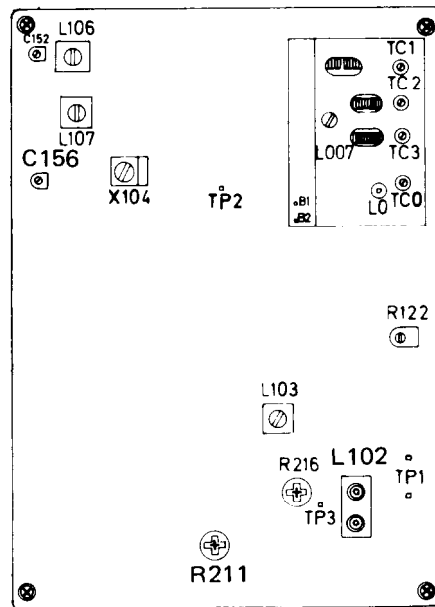
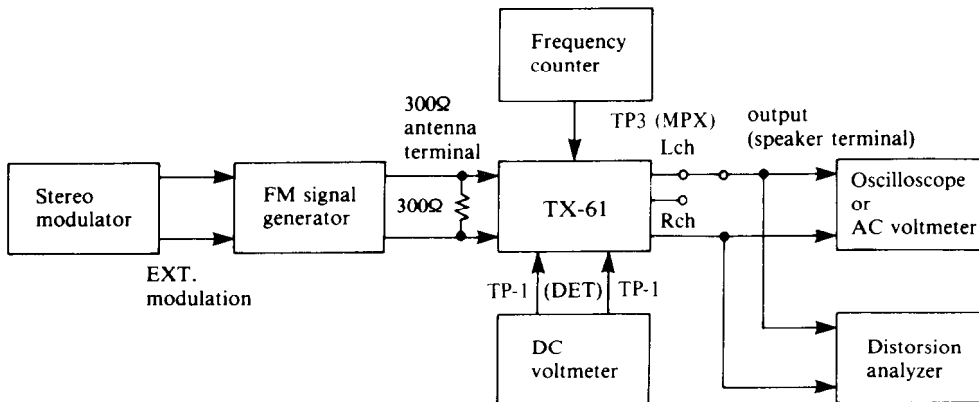

Fig 10

3. FM adjustment



Item	FM signal generator	Stereo modulator	Dial to set	Adjust	Output indicator	Adjust for	Remarks
FM IF	1	_____	No input signal	L102 BACK	DC voltmeter	0V	Repeat steps 1 and 2 as necessary
	2	98.1MHz, 65dBf, 1kHz, 75kHz devi.	98.1MHz	L102 FRONT	Distorsion analyzer	Minimum	
V.C.O	98.1MHz 65dBf	_____	98.1MHz	R216	Frequency counter	76kHz	Turn off the modulation
Stereo Separation	98.1MHz 65dBf Ext. modulation	Rch	98.1MHz	R211	AC voltmeter (Lch)	Minimum	Maximum and same separation
		Lch			AC voltmeter (Rch)	Minimum	
Muting level	98.1MHz, 17dBf 1kHz, 75kHz devi.	_____	98.1MHz	R122	Oscilloscope	Signal	Set the muting switch to on position
	98.1MHz, 16dBf 1kHz, 75kHz devi.	_____				No signal	

**4. AM IF adjustment**

1. Set the dial to quiet point.

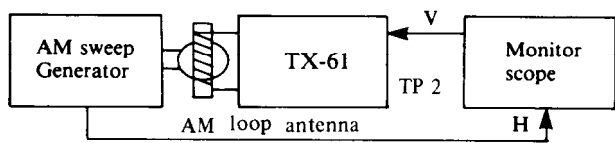

Set signal	Adjust	Adjust for
450 kHz	X104	The output of monitor scope becomes maximum symmetrical response

Remark : Usually not necessary to adjust.

**5. AM RF adjustment**

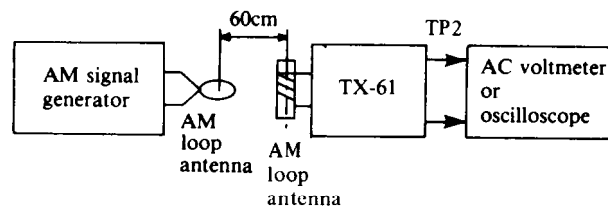

	AM Signal generator	Dial to set	Adjust	Adjust for
1	600kHz (603kHz) 400Hz, 30% mod.	600kHz (603kHz)	L106	Maximum
2	1400kHz (1404kHz) 400Hz, 30% mod.	1400kHz (1404kHz)	C152	Maximum
3	Repeat steps 1 and 2 as necessary			

NOTE : ( ) : 220 V model

**6. Idling Current Adjustment**

Connect the DC voltmeter between ID and CT terminals.

Adjust the semi-fixed resistors R514 and R614 so that the reading of voltmeter becomes  $12 \pm 3mV$ .

Notes : Adjust after switching on for 5 minutes.

Open load, VOLUME.....Minimum, TAPE-1.....ON

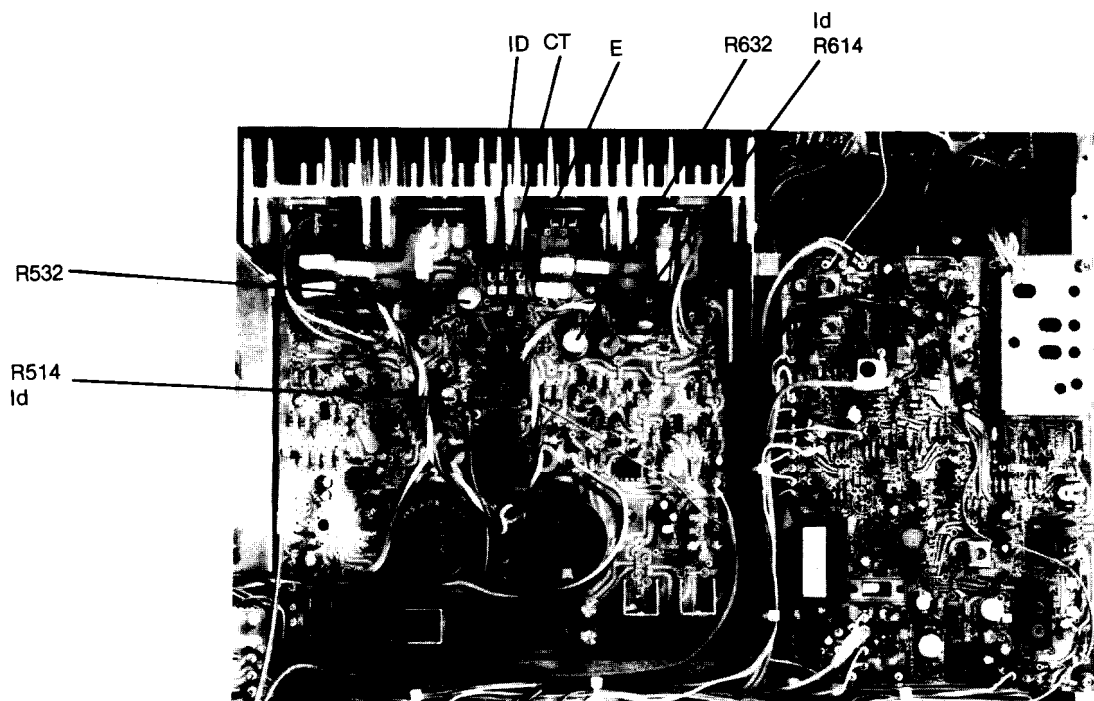
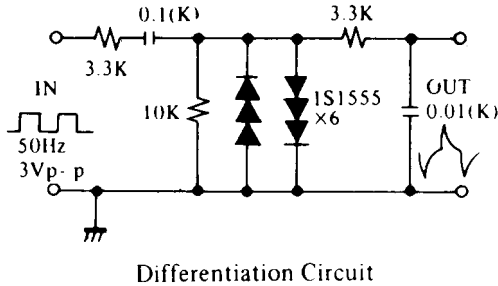
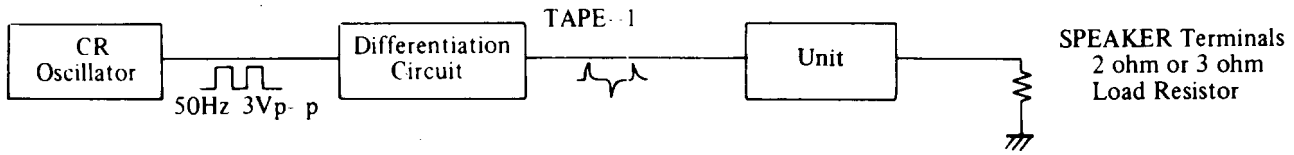

Fig. 11

## 7. Current Detector Circuit Adjustment



Apply a tone burst signal to the TAPE-1 terminals. Connect a 2Ω hollow resistor to the speaker terminals, and adjust variable resistor R532 (Lch) or R632 (Rch) so that the relay is operated at maximum volume. Connect a 3Ω hollow resistor to the speaker terminals. Confirm the relay is not operated at maximum volume. (See Fig. 11)

NOTES: Adjust after switching on for 5 minutes.  
VOLUME-Maximum

## 8. Center Voltage Check

When the transistor of the differential amp, the power amplifier or the constant current circuit has been replaced, check the center voltage.

Connect a DC VTVM between the CT and E terminals and check if the reading of the DC VTVM is within  $\pm 10\text{mV}$ . Perform this check 5 minutes after the power switch has been set to On.

## 9. CX Decoder Adjustment

1. Apply the sine wave signal of 1kHz, 2.5mV to the PHONO terminal of left-ch. (right-ch.).
2. Insert the shorted pin to the PHONO terminal of right-ch. (left-ch). (See Fig. 14)
3. Connect the DC voltmeter to the terminal TP-2.
4. Adjust the variable resistor R731 (R732) on the back panel so that the reading of voltmeter become 5V. Confirm that the L.E.D. of back panel light on. Specifications; 4.6 to 5.4V.
5. Connect the DC voltmeter to terminal TP-3L (TP-3R). Adjust the semi-fixed resistor R765 (R766) so that the reading of voltmeter become 150mV.
6. Proceed for right channel in the same manner.
7. Apply the tone burst signal of 1kHz, 2.5mV as shown fig. 13 to the PHONO terminal of left-ch. (right-ch).
8. Connect the DC voltmeter to the terminal TP-3R (TR-3L). Adjust the R760 (R759) so that the reading of voltmeter become 0V.
9. Proceed for right channel in the same manner.

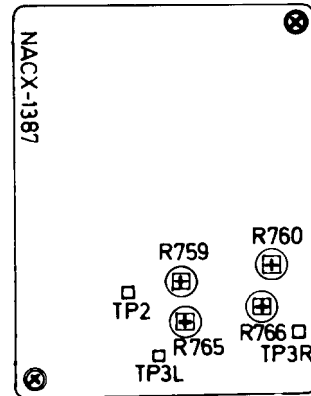

Fig. 12

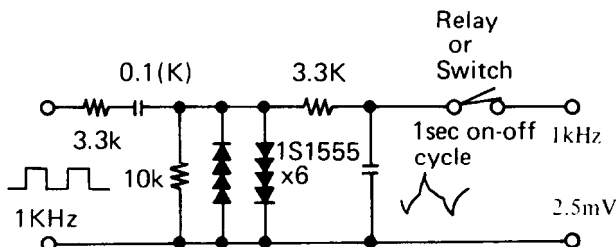

Fig. 13

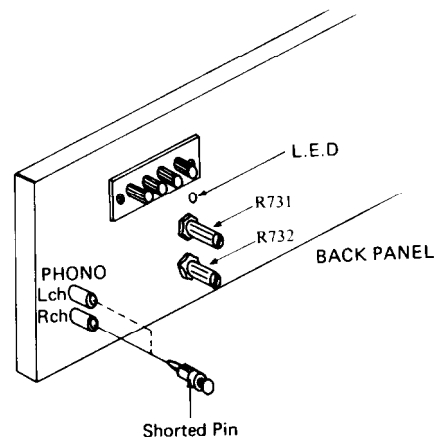
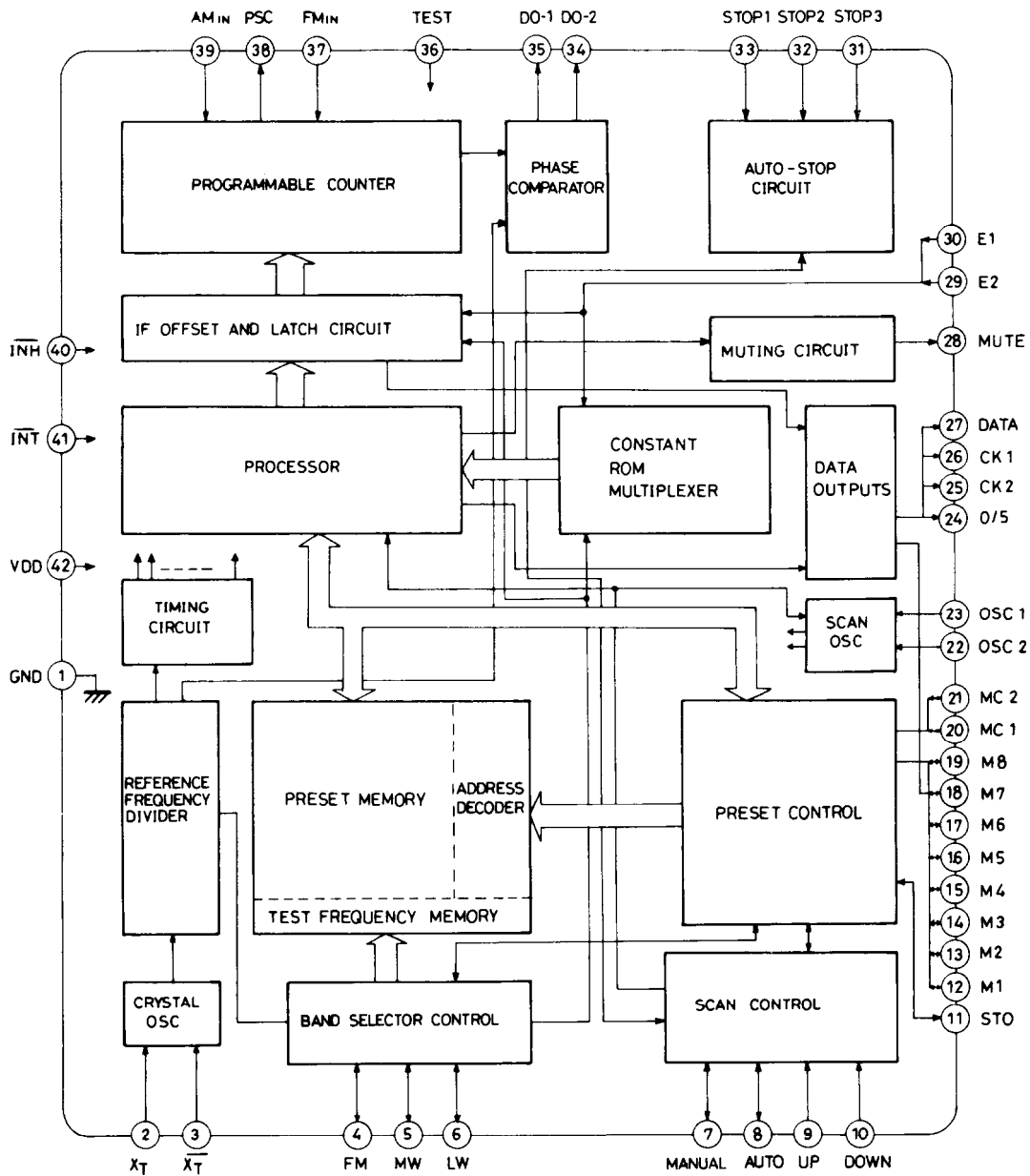

Fig. 14

# BLOCK DIAGRAM OF IC

TC9147P (Micro computer)



# BA6124 (Signal meter driver)

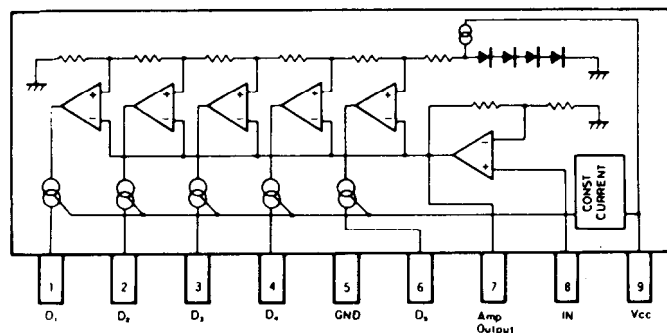

**TD6301AP (Fluorescent indicator tube driver)**

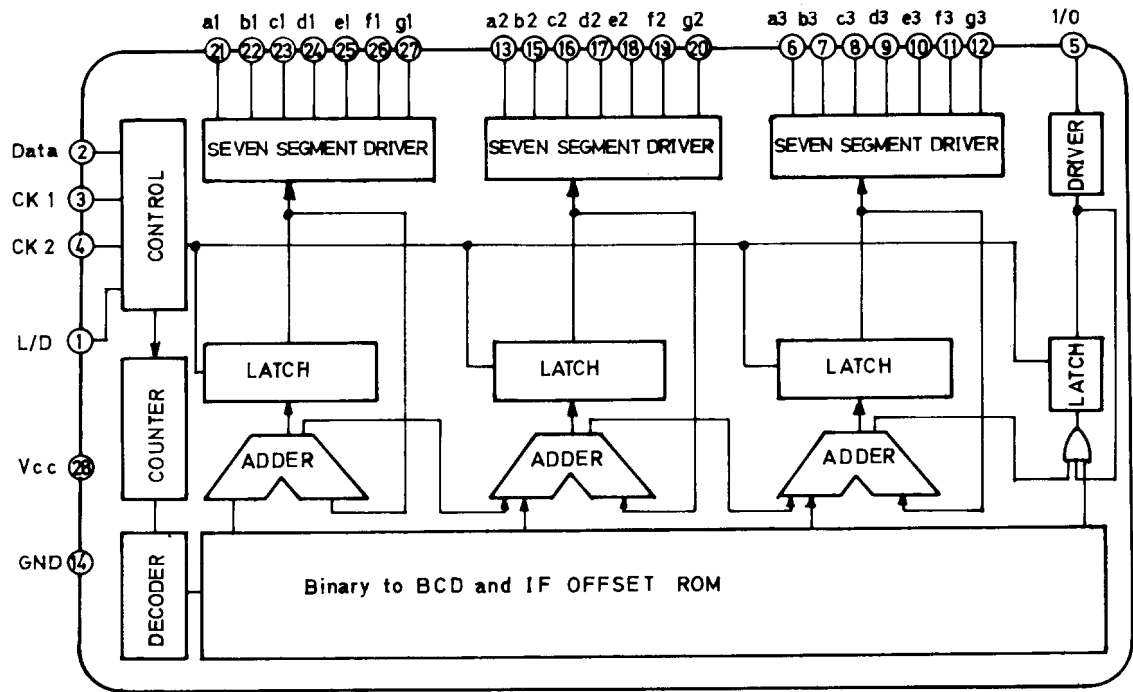

**TD6104P (Prescaler)**

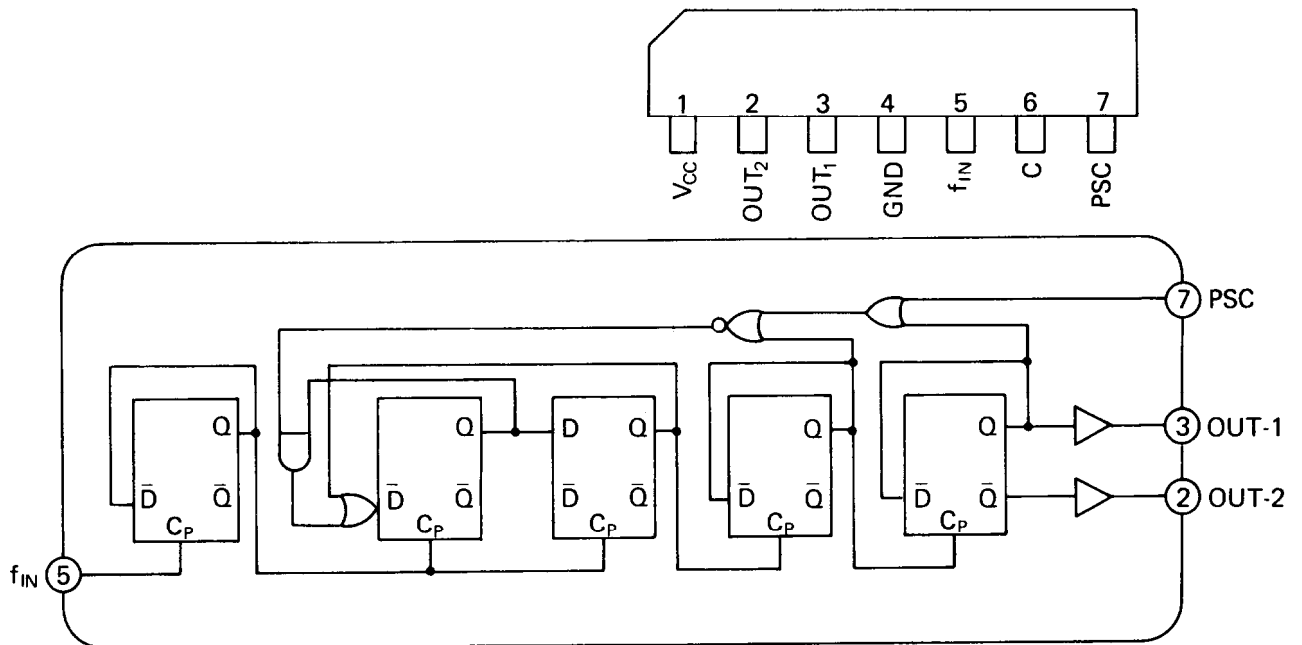



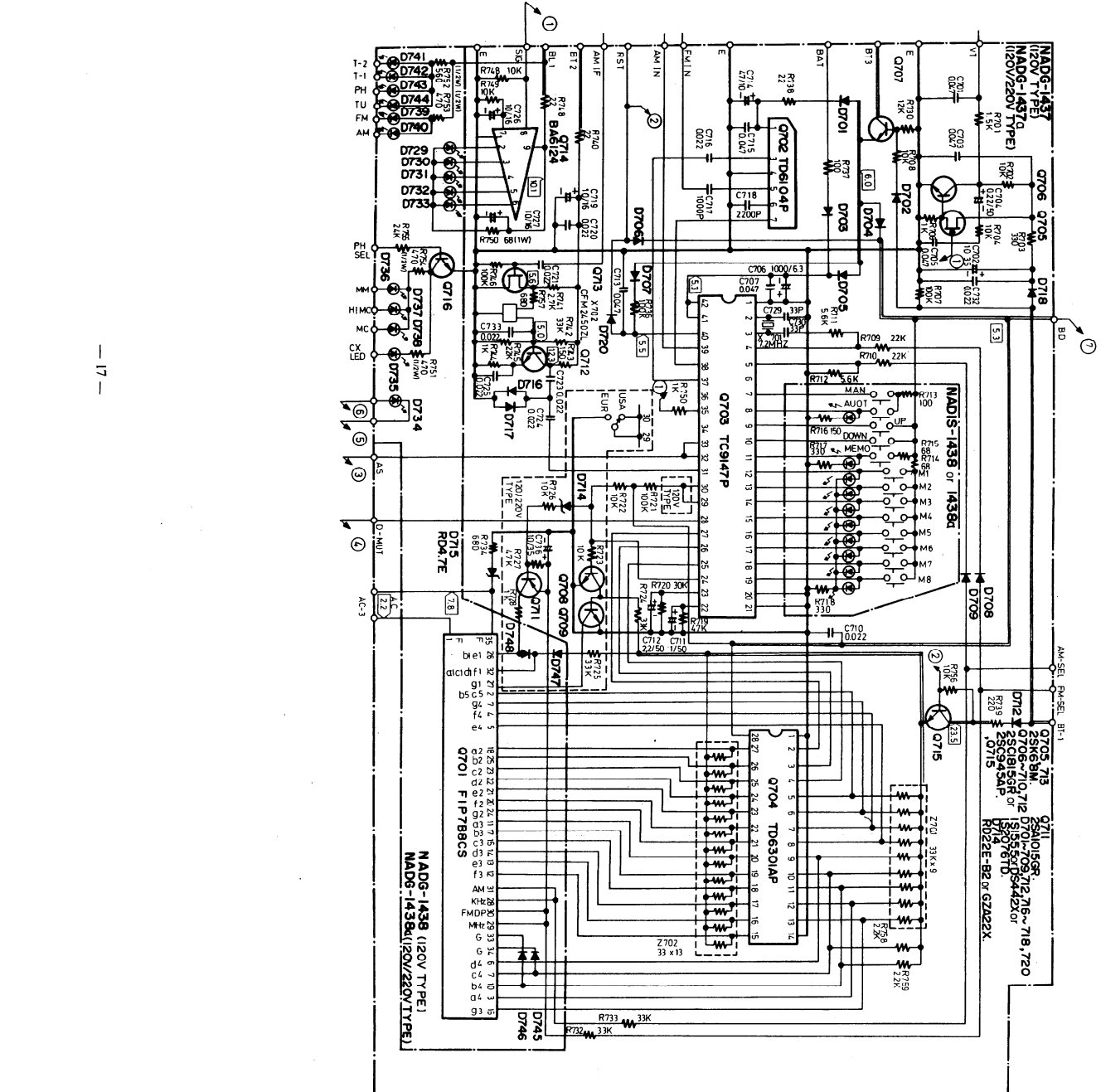

DIGITAL CIRCUIT PC BOARD (NADG-1437/6)

CIRCUIT NO.	PARTS NO.	DESCRIPTION
Q702	IC5	TD6104P, Prescaler
Q703	222674	TC9147P, PLL synthesizer and controller
Q704	222673	TD6301AP, Frequency indicator driver
Q714	222670	BA6124, Signal meter driver
Q705, Q713	221103	Transistors (ID model)
Q706, Q707	221130	2SK684 (N)
Q712, Q715	221076	2SC1815 (GR) or 2SC945A (P)
Q705	221130	Transistors (W model)
Q706-Q709	221135	2SK684 (N), F.E.T
Q712, Q715	221076	2SC1815 (GR) or 2SC945A (P)
Q711	221145	2SA1015 (Y) or 2SA1015 (GR)
Q713	221145	2SA1015 (Y) or 2SA1015 (GR)
D701-D709	221130	Diodes (ID model)
D716-D718	223103	1S1555
D712, D720	223133	DS442X or DS442X or DS442X or DS442X
D715	223145	1S2076TD
	223944	RD4, 7E-B or RD4, 7E-C
	223943	Diodes (W model)
D701-D709	223103	1S1555
D712, D720	223133	DS442X or DS442X or DS442X or DS442X
D716-D718	223145	1S2076TD
D714	223975	RD22E, B2 or RD4, 7E (C) or RD4, 7E (B)
D715	223944	RD4, 7E (C) or RD4, 7E (B)
	223943	Diodes (W model)
X701	3010073	Crystal
X702	3010048	XTL-7.2M
C702	352761009	Capacitors
C704	359162297	10uF, 35V, Elect.
C706	352721029	0.22uF, 35V, Tantalum
C711	352780109	1uF, 50V, Elect.
C712	352780229	1uF, 50V, Elect.
C714	352734709	2.2uF, 50V, Elect.
C719	352741009	47uF, 10V, Elect.
C716, C727	352741009	10uF, 16V, Elect.
C736	352761009	10uF, 35V, Elect. (W)
R730	441626804	Resistors
Z701	49121333509	680, 1W, Metal oxide film
Z702	49121333513	33kOhm, 1/8W, Network

**SCHEMATIC DIAGRAM**

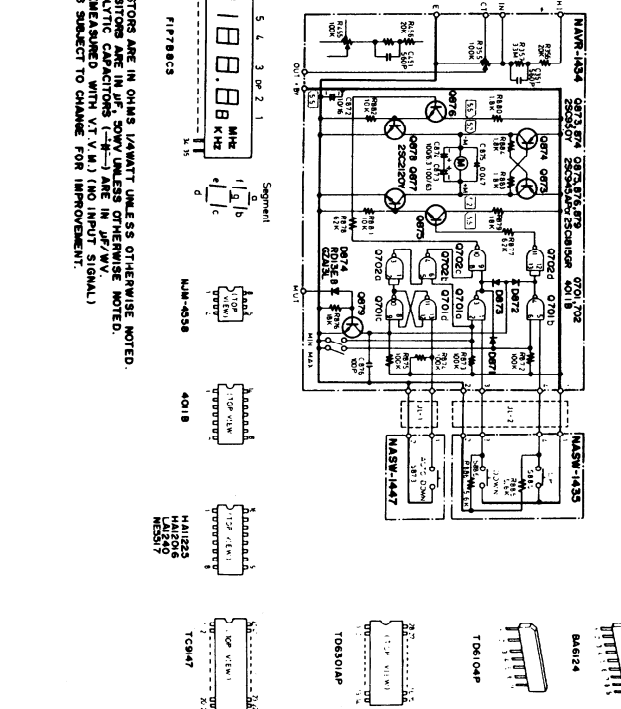
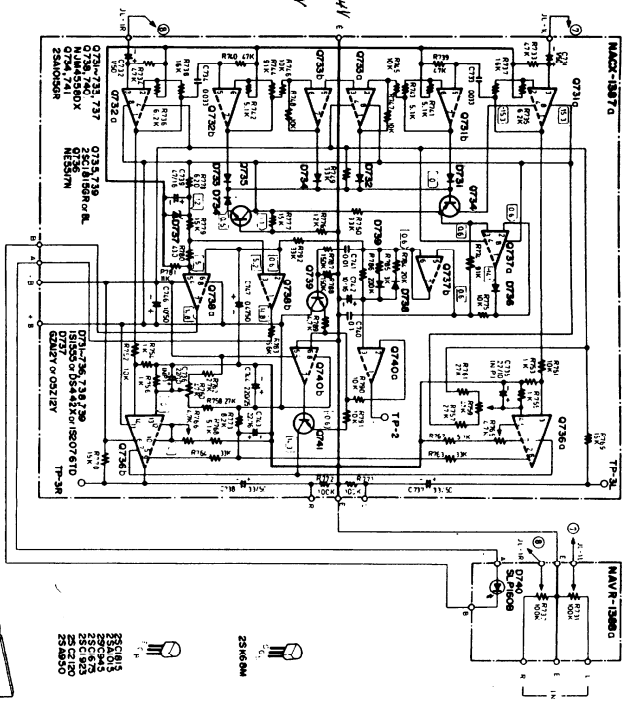
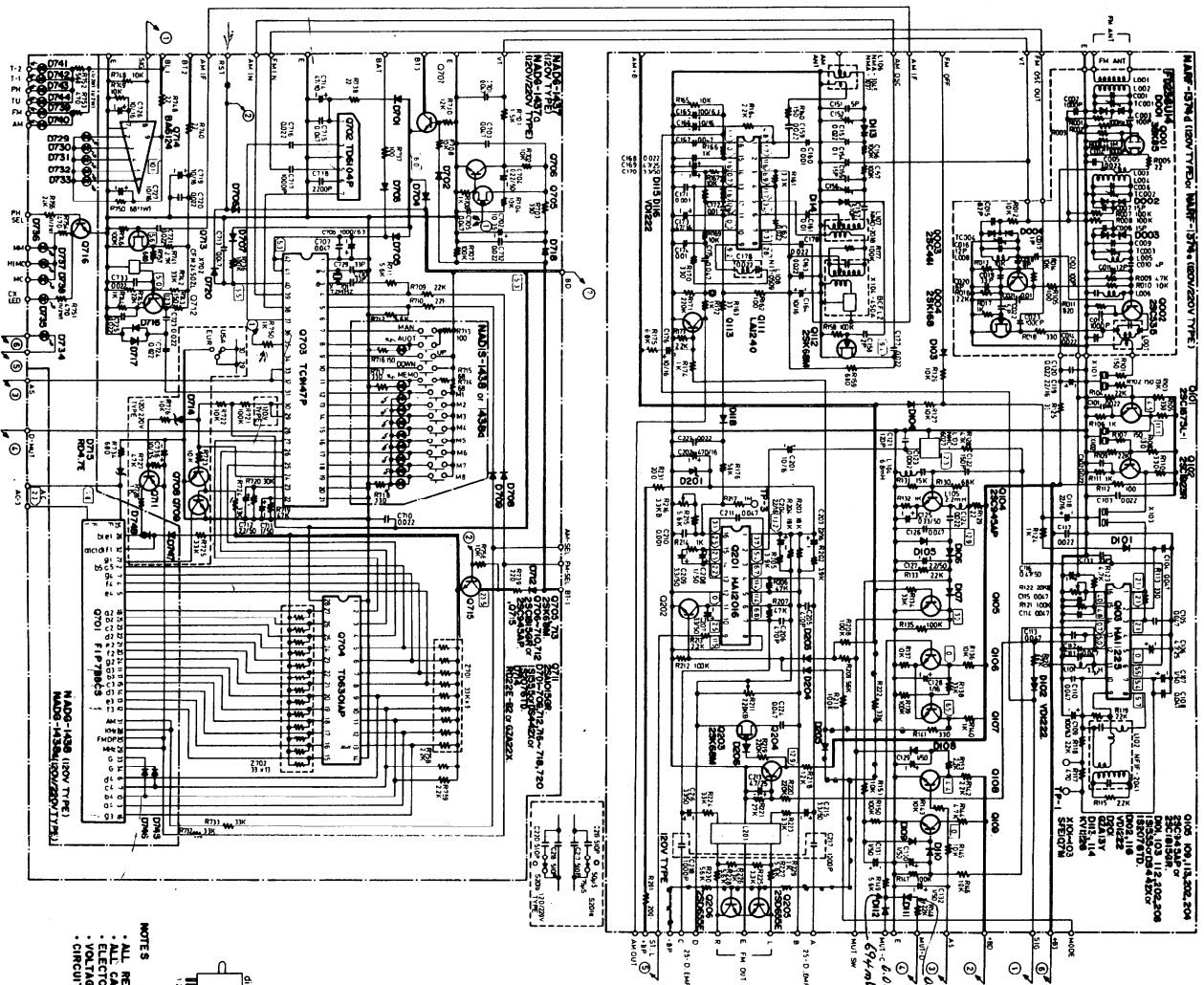

- NOTES**
- ALL RESISTORS ARE IN OHMS UNLESS OTHERWISE NOTED.
  - ALL CAPACITORS ARE IN MICROFARADS UNLESS OTHERWISE NOTED.
  - ELECTROLYTIC CAPACITORS ARE SHOWN WITH POLARITY INDICATED.
  - VOLTAGE (MEASURED WITH VT V.M.) (NO INPUT SIGNAL).
  - CIRCUIT IS SUBJECT TO CHANGE FOR IMPROVEMENT.

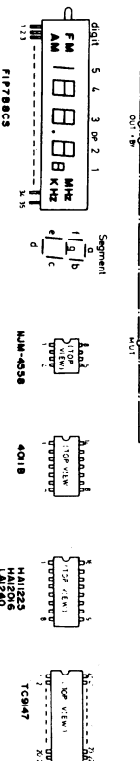

**DISPLAY PC BOARD (NADIS-1438)**

<b>CIRCUIT NO.</b>	<b>PARTS NO.</b>	<b>DESCRIPTION</b>
	<b>Fluorescent indicator tube</b>	
Q701	212016	FIP7B8CS
	<b>Transistor</b>	
Q716	2211255 or 2210746	2SC1815 (GR) or 2SC945A (P)
	<b>L.E.Ds</b>	
D719	225028	GL9PG59
D720	225029	GL9PR9
D721-D728	225057	SR538D
D729-D733	225028	GL9PG59
D734	225059	GL9PR9
D735	225112	GL-9HY84
D736-D738	225028	GL9PG59
D739,D740	225111	GL-9PG54
D741-D744	225112	GL9HY84
	<b>Diodes</b>	
D745,D476	223105, 223133 or 223145	1S15555, DS442X or 1S2076TD
	<b>Resistors</b>	
R751,R753	441524714	470Ω, 1/2W, Metal oxide film
R752	441525614	560Ω, 1/2W, Metal oxide film
R754	441524714	470Ω, 1/2W, Metal oxide film
	<b>Switches</b>	
S701-S713	25035275	NPS-111-S239
	<b>Holder ass'y</b>	
A853	13258903	
	<b>Knobs</b>	
A801	28320774	TAPE2
A802	28320775	TAPE1
A803	28320776	PHONO
A804	28320777	TUNER
A805	28320778	FM
A821	28320811	STATION 1
A822	28320812	STATION 2
A823	28320813	STATION 3
A824	28320814	STATION 4
A825	28320815	STATION 5
A826	28320816	STATION 6
A827	28320817	STATION 7
A828	28320818	STATION 8
A829	28320809	RED
A830	28320808	MEMORY
A831	28320779	TUNING
	<b>Screws</b>	
A851	833130080	3TTB + 8P, Tapping
	<b>Washer</b>	
A852	870048	W3x8x0.8mm, Nylon
	<b>Cushion</b>	
	28140433	8x60x6mm, Fluorescent indicator tube

**DIAL/VOLUME ILLUMINATION LAMP PC BOARD (NAPL-1441/1442)**

<b>CIRCUIT NO.</b>	<b>PARTS NO.</b>	<b>DESCRIPTION</b>
PL801	210091	PL12V150mA, Blue cap, Edge lamp
PL802	210038	PL12V150mA, Volume indicator lamp

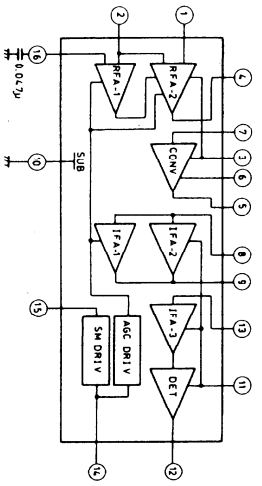
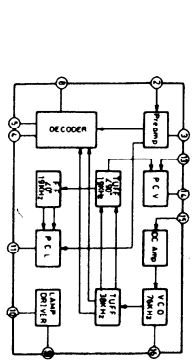
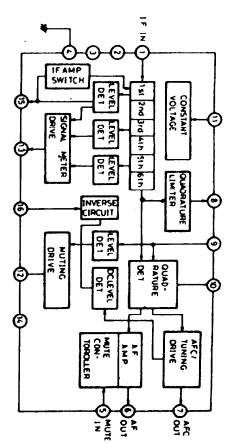
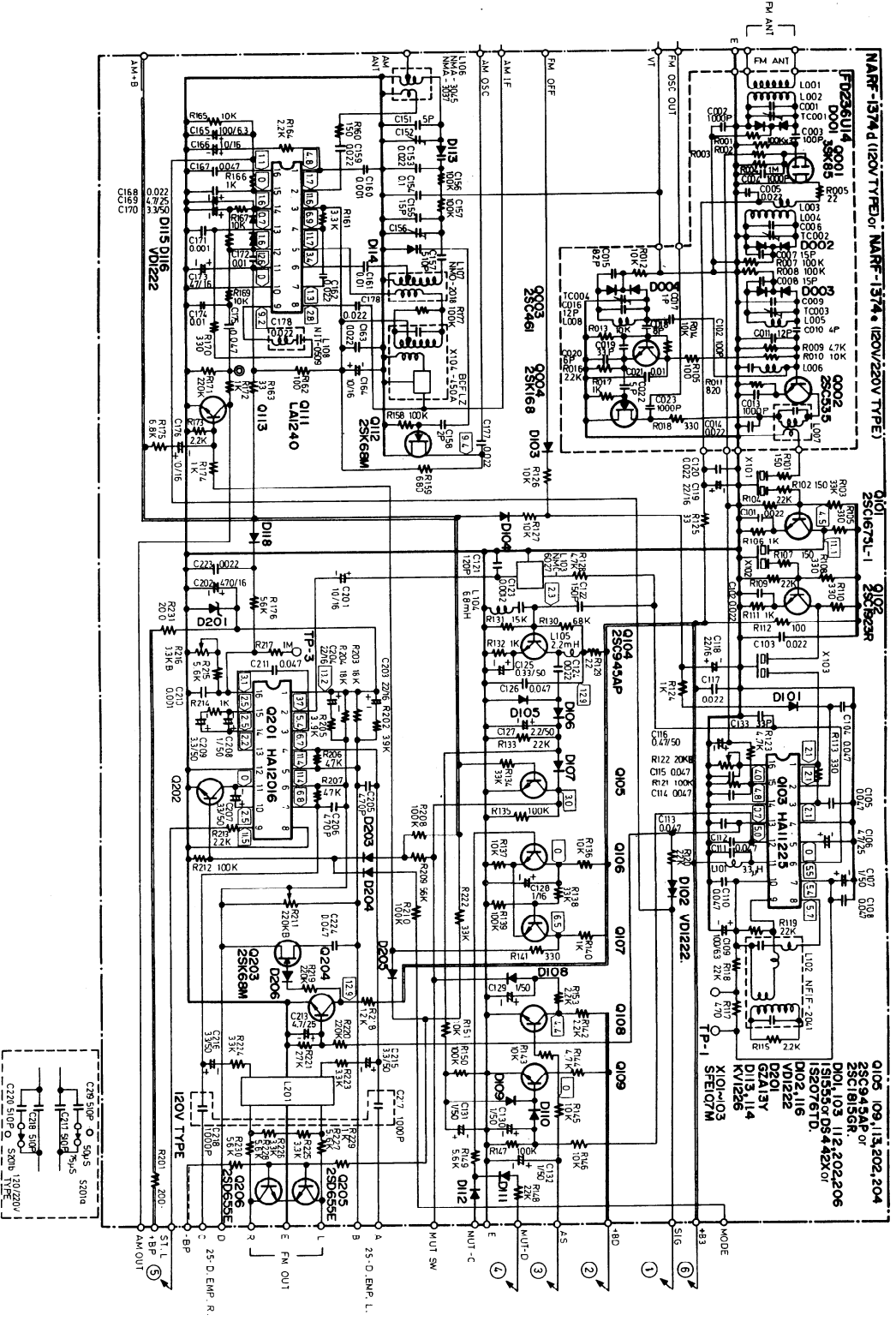

**PRINTED CIRCUIT BOARD-PARTS LIST  
FM/AM TUNER PC BOARD (NARF-1374d/e)**

CIRCUIT NO.	PARTS NO.	DESCRIPTION
	<b>Front end</b>	
	240043	FD236U14
	<b>ICs</b>	
Q103	222540	HA11225, FM IF system
Q111	222497	LA1240, AM radio system
Q201	222593	HA12016, Stereo decoder
	<b>Transistors</b>	
Q101	2210823	2SC1675 (L-1)
Q102	2211722	2SC1923 (R)
Q104	2210746	2SC945A (P)
Q105-Q109	2210746,	2SC945A (P),
Q113,Q202	2211255 or	2SC1815 (GR) or
Q204	2212115	2SC2458 (GR)
Q112,Q203	2211302 or	2SK68A (L) or
	2211303	2SK68A (M)
Q205,Q206	2211705	2SD655 (E)
	<b>Diodes</b>	
D101,D103	223105,	1S1555,
D104-D112	223133 or	DS442X or
D115,D118	223145	1S2076TD
D102,D116	4000068	VD1222
D113,D114	223136	KV1226
D201	2241132 or	GZA13Y or
	2242911	EQA0213A
D203-D206	223105,	1S1555,
	223133 or	DS442X or
	223145	1S2076TD
	<b>Coils</b>	
L101	233105 or	NCH-1005 or
	233024	NCCH-1501
L103	233236	NMC-6027
L104	233122	NCH3013
L105	233031	NMC-9-1
L106	232107 or	NMA-3045 or
	232089	NMA-3037
L107	232084	NMO2018
L201	233032A	NMC-8-7
	<b>Transformers</b>	
L102	233274	NFIF6041
L108	232041	NIT-0509
	<b>Ceramic filters</b>	
X101-X103	3010024	SFE10.7MLA
X104	3010058	BCFLZ450A
	<b>Capacitors</b>	
C106	352750479	4.7 $\mu$ F, 25V, Elect.
C107	352780109	1 $\mu$ F, 50V, Elect.
C109	352721019	100 $\mu$ F, 6.3V, Elect.
C116	352784799	0.47 $\mu$ F, 50V, Elect.
C118,C119	352742209	22 $\mu$ F, 16V, Elect.
C125	352783399	0.33 $\mu$ F, 50V, Elect.
C127	352780229	2.2 $\mu$ F, 50V, Elect.
C128-C132	352780109	1 $\mu$ F, 50V, Elect.
C152,C156	3060010	NTC-20P09, Trimmer
C157	372525114	510pF $\pm$ 5%, 50V, Styrol
C164,C166	352741009	10 $\mu$ F, 16V, Elect.
C165	352721019	100 $\mu$ F, 6.3V, Elect.
C169	352750479	4.7 $\mu$ F, 25V, Elect.
C170	352780339	3.3 $\mu$ F, 50V, Elect.
C173	352744709	47 $\mu$ F, 16V, Elect.
C176	352741009	10 $\mu$ F, 16V, Elect.
C201	352741009	10 $\mu$ F, 16V, Elect.
C202	352744719	470 $\mu$ F, 16V, Elect.
C203,C204	352742209	22 $\mu$ F, 16V, Elect.
C205,C206	372524714	470pF $\pm$ 5%, 50V, Styrol
C207,C209	352780339	3.3 $\mu$ F, 50V, Elect.
C208	352780109	1 $\mu$ F, 50V, Elect.
C210	372621024	1,000pF $\pm$ 5%, 50V, Styrol
C213	3526750479	4.7 $\mu$ F, 25V, Elect.
C215,C216	352780339	3.3 $\mu$ F, 50V, Elect.
C217,C218	372521024	1,000pF $\pm$ 5%, 50V, Styrol (D)
C217-C220	372525114	510pF $\pm$ 5%, 50V, Styrol (W)

CIRCUIT NO.	PARTS NO.	DESCRIPTION
	<b>Resistors</b>	
R122	5215046	N08HR50KBC, Semi-fixed
R211	5225037	N10HR220KBD, Semi-fixed
R216	5225029	N10HR3.3KBD, Semi-fixed
	<b>Switch</b>	
S201	250142	NSS2225, De-emphasis (W)
	<b>Screws</b>	
	82142604	2.6P + 6F (BC), Pan head

**MUTING/DE-EMPHASIS SWITCH PC BOARD  
(NASW-1439)**

CIRCUIT NO.	PARTS NO.	DESCRIPTION
S311,S312	25035330	NPS-222-L294, Switch

Note : D : Only 120V model  
W : Only 12/220V model

**Muting switch pc board**

HA12017 (Equalizer amplifier)

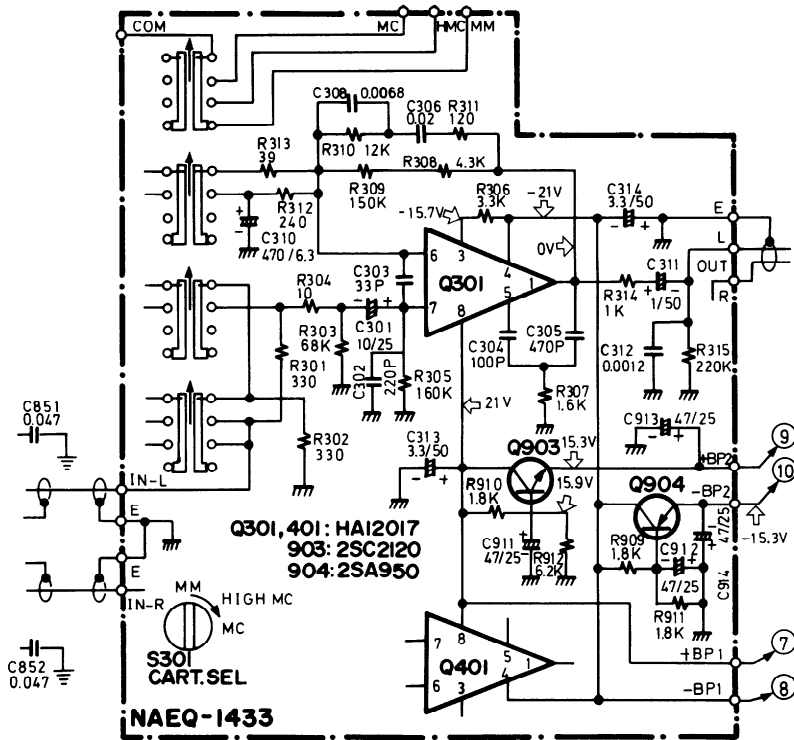
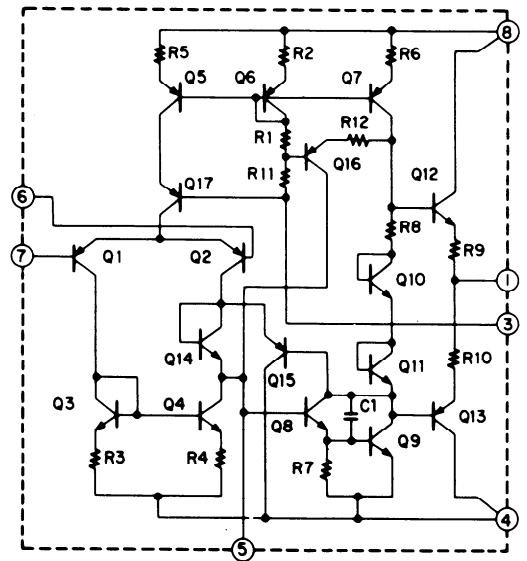

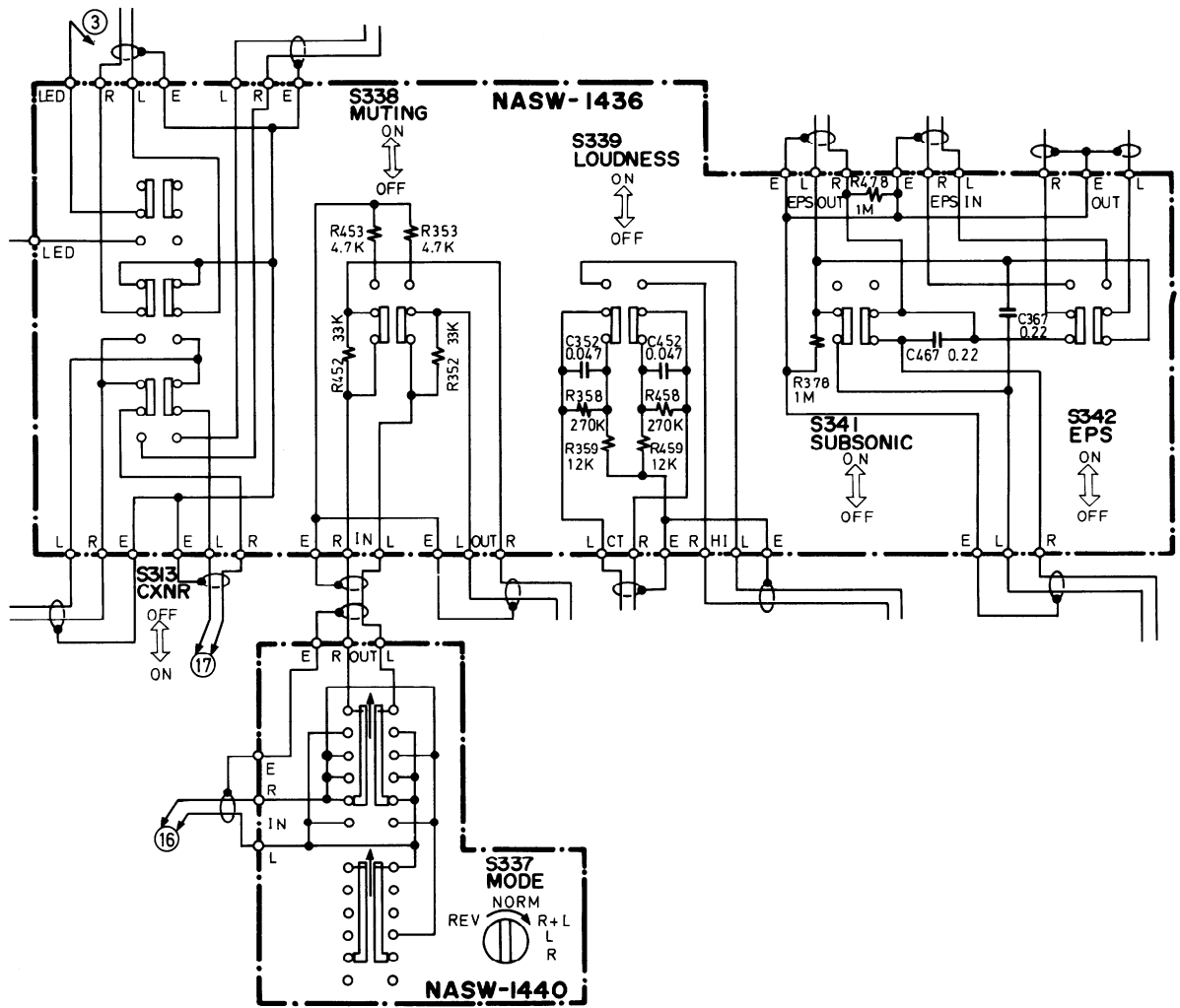

**NJM4559DX (Operation amplifier)**

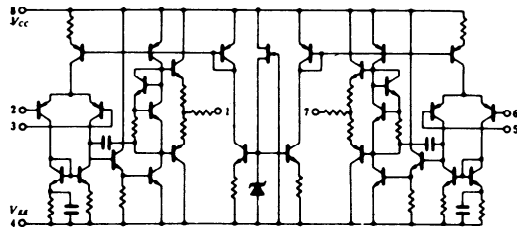

- 1.7 Output
- 2.6 Inverse input
- 3.5 Input

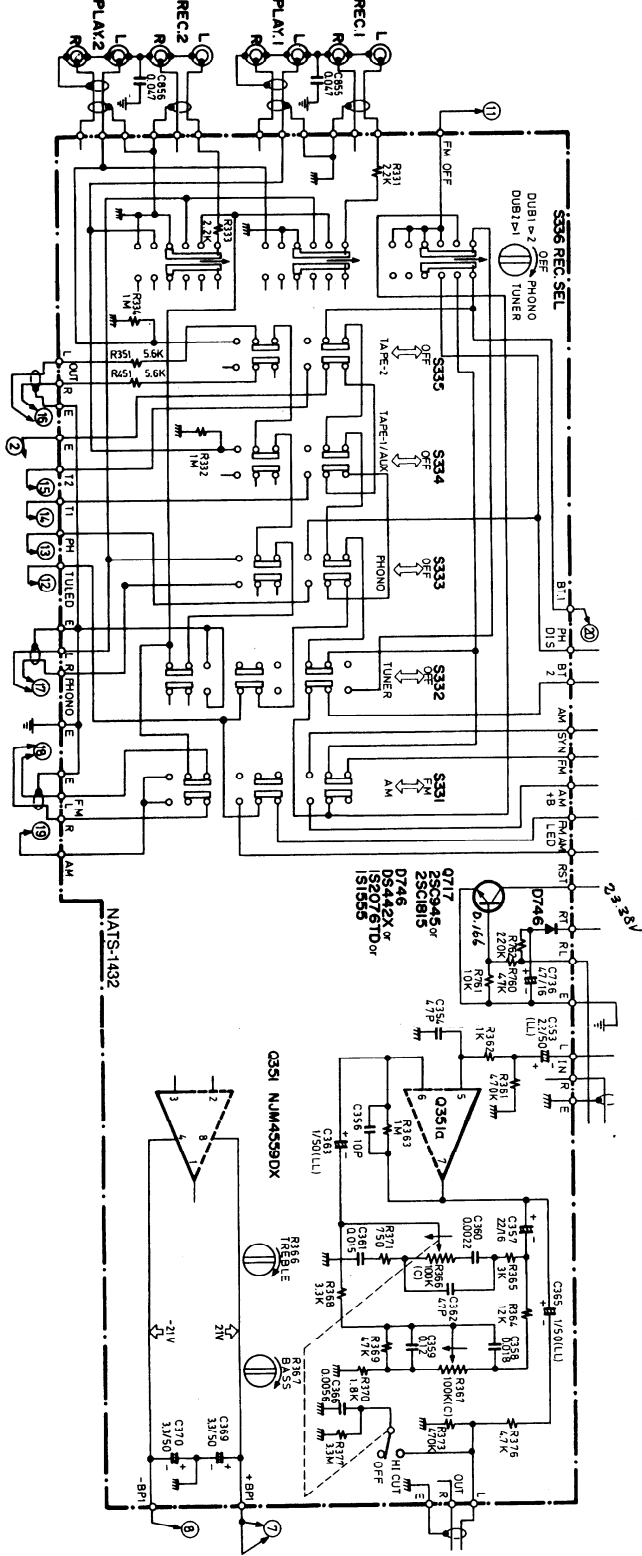

**EQUALIZER AMPLIFIER PC BOARD (NASW-1433)**

CIRCUIT NO.	PARTS NO.	DESCRIPTION
Q301, Q401	ICs 222594	HA12017
Q903	Transistors 2211163 or 2211164	2SC2120 (O) or 2SC2120 (Y)
Q904	2211503 or 2211504	2SA490 (O) or 2SA490 (Y)
C301, C401	Capacitors 392851007	10uF, 25V, LL
C310, C410	357274719	470uF, 6.3V, Elect.
C311, C411	357780109	1uF, 50V, Elect.
C313, C413	352780359	3.3uF, 50V, Elect.
C314, C414	352780359	3.3uF, 50V, Elect.
C315, C415	352782209	22uF, 50V, Elect.
C911, C914	352754709	47uF, 25V, Elect.
S301 a-d	Switch 25065207	NSS-8392, Cartridge selector

**MODE SWITCH PC BOARD (NASW-1440)**

CIRCUIT NO.	PARTS NO.	DESCRIPTION
S337	25030223	NRSM-145-25SS

**OPERATION SWITCH PC BOARD (NASW-1436)**

CIRCUIT NO.	PARTS NO.	DESCRIPTION
S313, S338	25035331	NPS-162-442-L295,
S339, S341		CX/MUTE/LOUDNESS/SUB
S342		FL/EBS
	27140677	Bracket, switch
	82113006	3P + 6FN, Pan head screw

**TONE AMPLIFIER AND SWITCH CIRCUIT PC BOARD (NATS-1432)**

CIRCUIT NO.	PARTS NO.	DESCRIPTION
Q301, Q401	IC 222534	NIM-4599DX
Q717	Transistor 2211255 or 2210746	2SC1815 (GR) or 2SC454 (P)
D746	Diode 223105, 223105, 223133 or 223145	1S1555, DS442X, or 1S2076TD
C353, C453	Capacitors 392880227	2.2uF, 50V, LL
C357, C457	352752209	22uF, 16V, Elect.
C363, C463	392880107	1uF, 50V, LL
C365, C465	352780109	1uF, 50V, Elect.
C369, C370	352780359	3.3uF, 50V, Elect.
C736	352741009	10uF, 16V, Elect.
R366, R466	Resistors 5148082	N16RQMS1C100KC025M, Tre-
R367, R467	5148081	ble control
		N16RQMI1C100KCS25M, Bass
		control
S331, S333	Switches 25035318	NPS-262-344-L282, Selector
S336	25030219	NRSM-165-23SS, Rec. selector
	Plates 27150155	Shielded
	28175055	Insulator



### Auto volume circuit pc board

### AUTO VOLUME CIRCUIT PC BOARD (NAVR-1434)

CIRCUIT NO.	PARTS NO.	DESCRIPTION
	<b>ICs</b>	
Q701, Q702	222840111 or 222513	4011B or TC4011BP
	<b>Transistors</b>	
Q873, Q874	2211504	2SA950 (Y)
Q875, Q876	2211255 or 2210746	2SC1815 (GR) or 2SC945A (P)
Q877, Q878	2211164	2SC2120 (Y)
Q879	2211255 or 2210746	2SC1815 (GR) or 2SC945A (P)
	<b>Diodes</b>	
D871-D873	223105, 223133 or 223145	1S1555, DS442X or 1S2076TD
D874	223965 or 224113	RD13E-B or GZA13L
	<b>Capacitors</b>	
C872	352741009	10 $\mu$ F, 16V, Elect.
C873, C874	352721019	100 $\mu$ F, 6.3V, Elect.
	<b>Resistor</b>	
R355, R455	5104134	N16RTMS100KBTP15, Volume control variable

### UP/DOWN SWITCH PC BOARD PARTS LIST (NASW-1435)

CIRCUIT NO.	PARTS NO.	DESCRIPTION
	<b>Switches</b>	
S871, S872	25035275	NPS-111-S239

### AUTO DOWN SWITCH PC BOARD (NASW-1447)

CIRCUIT NO.	PARTS NO.	DESCRIPTION
S873	25035275	NPS-111-S239

### Auto down switch pc board

### UP/DOWN switch pc board

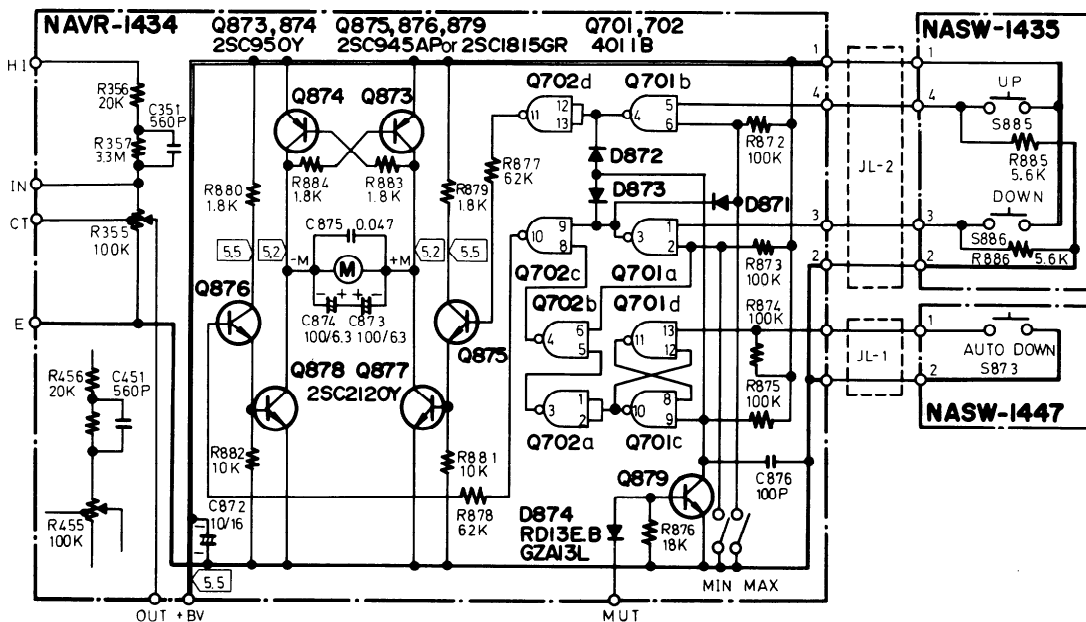

MODEL TX-61

SUBSTITUTIVE PARTS LIST

NOTE: USE THE REGULAR PARTS WHEN REPLACEMENT

TYPE	CIRCUIT NO.	DESCRIPTION	REGULAR PARTS	SUBSTITUTIVE PARTS	APPLICATION
UD	D735, 741-744	LED	GL9HY84Y	GL9HY84B	5021-5520
UD	Q701	FL TUBE	7B8CS	7B8BC	5521-6020
UD	Q731-Q733	IC	NJM4558DX	NJM4558DD	5021-5520
UD	Q733, 738, 740	IC	NJM4558DX	NJM4558DD	5021-5520

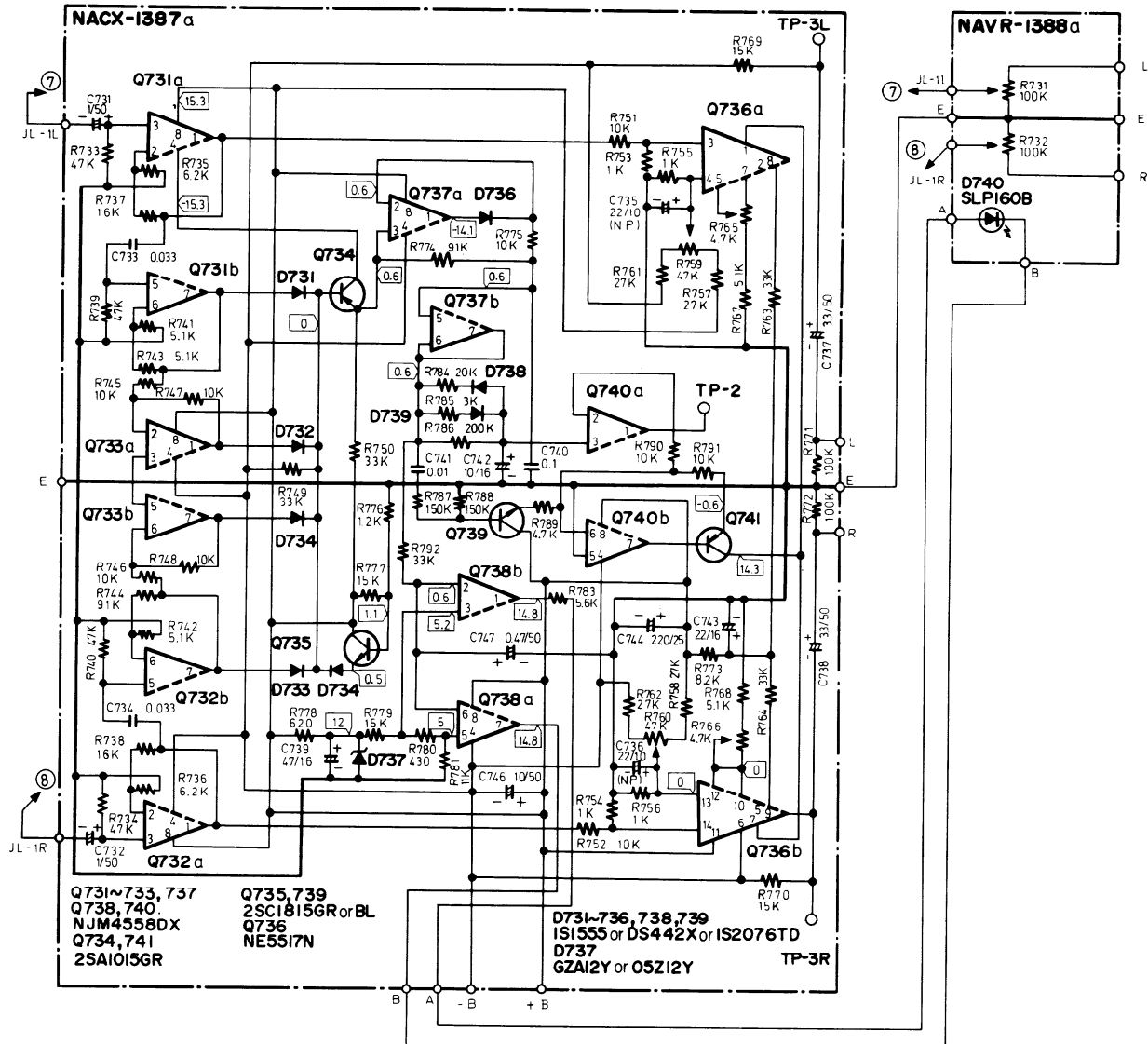

**CX DECODER PC BOARD (NACX-1387a)**

CIRCUIT NO.	PARTS NO.	DESCRIPTION
<b>ICs</b>		
Q731-Q733	222502	NJM-4558DX
Q736	222617	NE5517N
Q737, Q738	222502	NJM-4558DX
Q740		
<b>Transistors</b>		
Q734, Q741	2211455	2SA1015 (GR)
Q735, Q739	2211255 or 2211256	2SC1815 (GR) or 2SC1815 (BL)
<b>Diodes</b>		
D731-D736	223105,	1S1555,
D738, D739	223133 or 223145	DS442X or 1S2076TD
D737	2241112 or 224187	GZA12Y or 05Z12Y
<b>Capacitors</b>		
C731, C732	352780109	1 $\mu$ F, 50V, Elect.
C735, C736	352932206	22 $\mu$ F, 10V, Non-polar elect.
C737, C738	352780339	3.3 $\mu$ F, 50V, Elect.
C739	352744709	47 $\mu$ F, 16V, Elect.
C742	352741009	10 $\mu$ F, 16V, Elect.
C743	352742209	22 $\mu$ F, 16V, Elect.
C744, C745	352752219	220 $\mu$ F, 25V, Elect.
C746	352781009	10 $\mu$ F, 50V, Elect.
C747	352784799	0.47 $\mu$ F, 50V, Elect.
<b>Resistors</b>		
R759, R760	5225034	N10HR47KBD, Semi-fixed
R765, R766	5225019	N10HR4.7KBD, Semi-fixed

**CX LEVEL CONTROL PC BOARD (NAVR-1388a)**

CIRCUIT NO.	PARTS NO.	DESCRIPTION
D740	225103	SLP-160B, L.E.D
R731, R732	5148083	N16RL100KB20Z, CX level control

**POWER SUPPLY CIRCUIT PC BOARD (NAPS-1444)**

CIRCUIT NO.	PARTS NO.	DESCRIPTION
<b>Transistors</b>		
Q931	2201073 or 2201074	2SD880 (O) or 2SD880 (Y)
Q932	2211255 or 2211256	2SC1815 (GR) or 2SC1815 (BL)
Q941	2200664 or 2200663	2SC1626 (Y) or 2SC1626 (O)
<b>IC</b>		
Q933	222780062	78M06
<b>Diodes</b>		
D931-D935	223804 or 223848	SR1K-2 or GP08B
<b>Lamps</b>		
PL803-PL805	210109	PL14V0.06AW4.0
PL806	210096	PL14V0.08AW-2
<b>Capacitors</b>		
C931	335251039	10,000pF, 500V, Ceramic
C932	352754709	47 $\mu$ F, 25V, Elect.
C933	352752229	2,200 $\mu$ F, 25V, Elect.
C934, C935	352744709	47 $\mu$ F, 16V, Elect.
C936, C937	352780339	3.3 $\mu$ F, 50V, Elect.
C941	352743329	3,300 $\mu$ F, 16V, Elect.
C942	352721019	100 $\mu$ F, 6.3V, Elect.
C943	352722219	220 $\mu$ F, 6.3V, Elect.
C944	352741029	1,000 $\mu$ F, 6.3V, Elect.
<b>Resistors</b>		
R931	442521004	10 $\Omega$ , 1/2W, Metal oxide film
R934	442523304	33 $\Omega$ , 1/2W, Metal oxide film
R941, R943	442521004	10 $\Omega$ , 1/2W, Metal oxide film
<b>Radiator</b>		
	27160029	RAD-07
<b>Screws</b>		
	82113008	3P + 8FN, Pan head

**FUSE TERMINAL PC BOARD (NAFU-1445/a)**

CIRCUIT NO.	PARTS NO.	DESCRIPTION
<b>(D model)</b>		
F901	252050	5A (ST-6), Primary fuse
F901a	250113	SN-5051, Fuse holder
<b>(W model)</b>		
F901	252020	5A—T, Primary fuse
F902	252075	2.5A-SE-EAK, Primary fuse
F901a	250113	SN-5051, Fuse holder
F902a	25050065	YSH403T, Fuse holder

**Power supply circuit pc board**

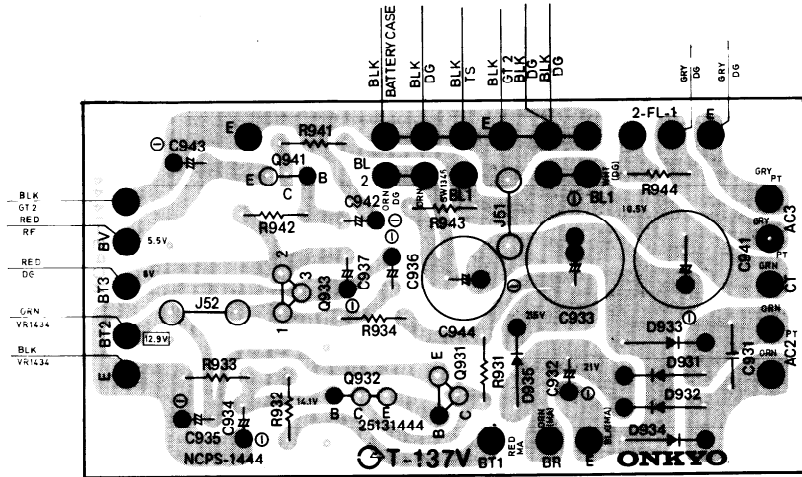

**Fuse terminal pc board**

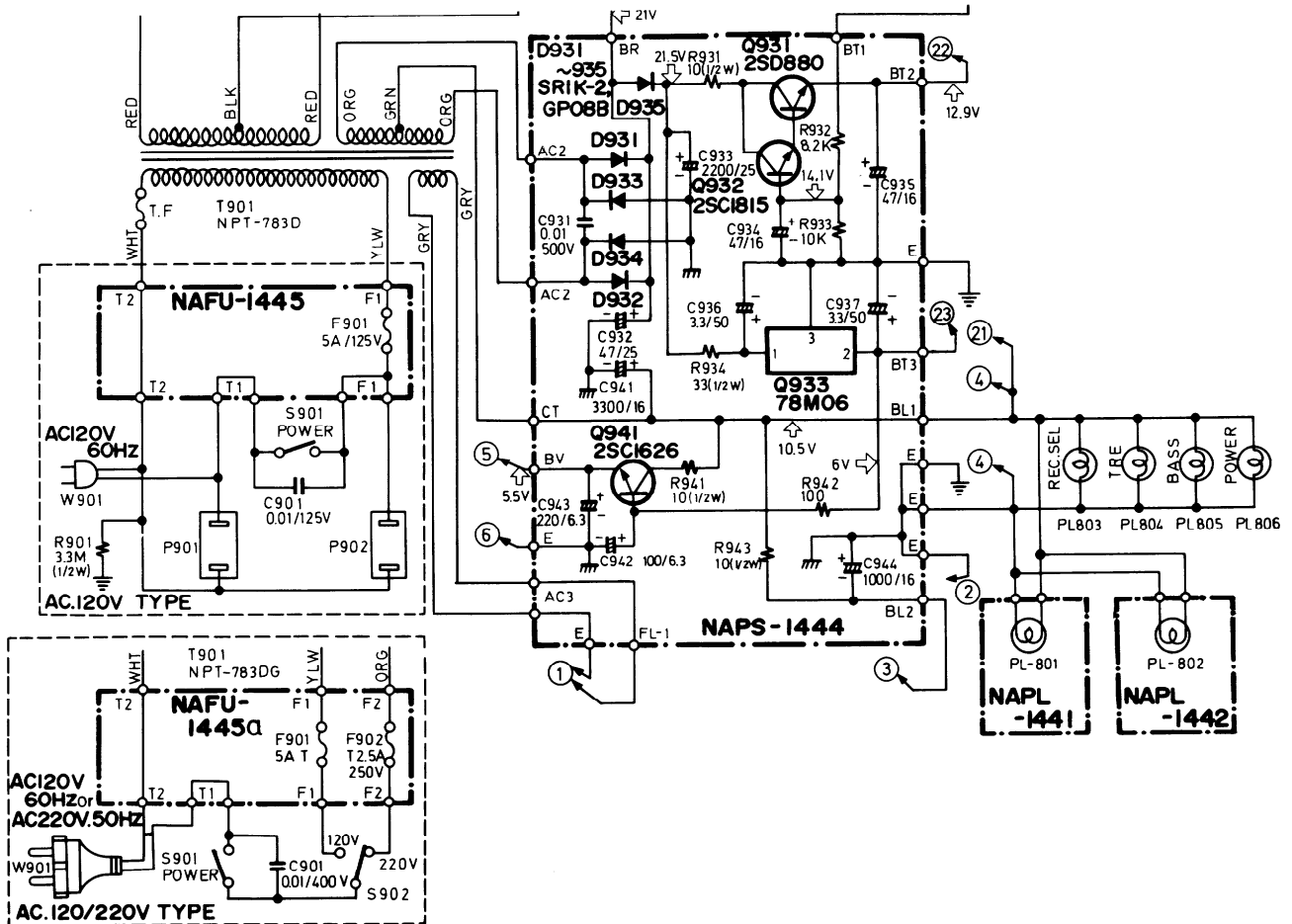
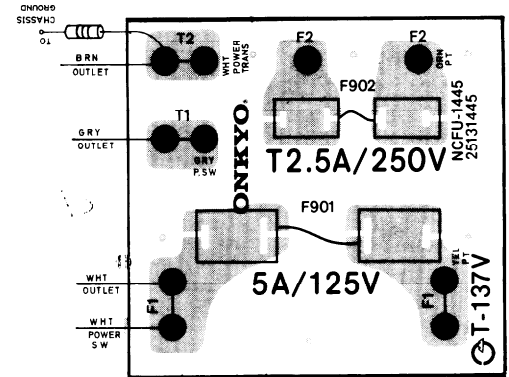

**SCHEMATIC DIAGRAM**

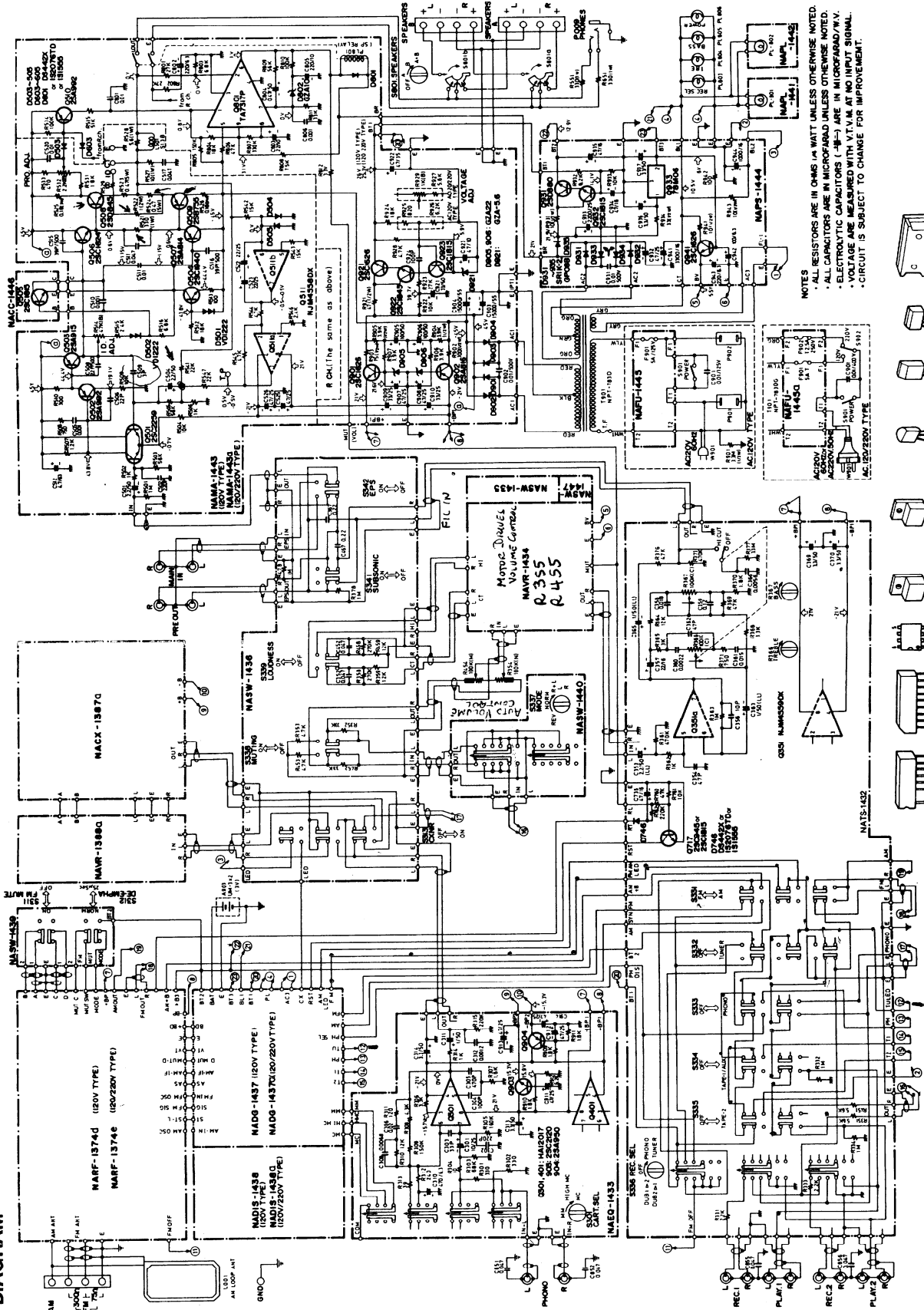

**NOTES**  
 \* ALL RESISTORS ARE IN OHMS UNLESS OTHERWISE NOTED.  
 \* ALL CAPACITORS ARE IN MICROFARADS UNLESS OTHERWISE NOTED.  
 \* ELECTROLYTIC CAPACITORS (E-8) ARE IN MICROFARADS.  
 \* VOLTAGE ARE MEASURED WITH V.T.M. IN SIGNAL.  
 \* CIRCUIT IS SUBJECT TO CHANGE FOR IMPROVEMENT.

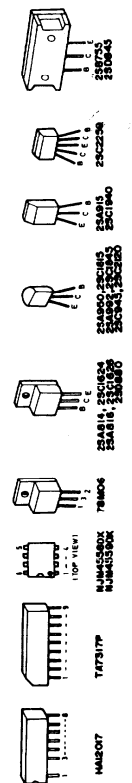

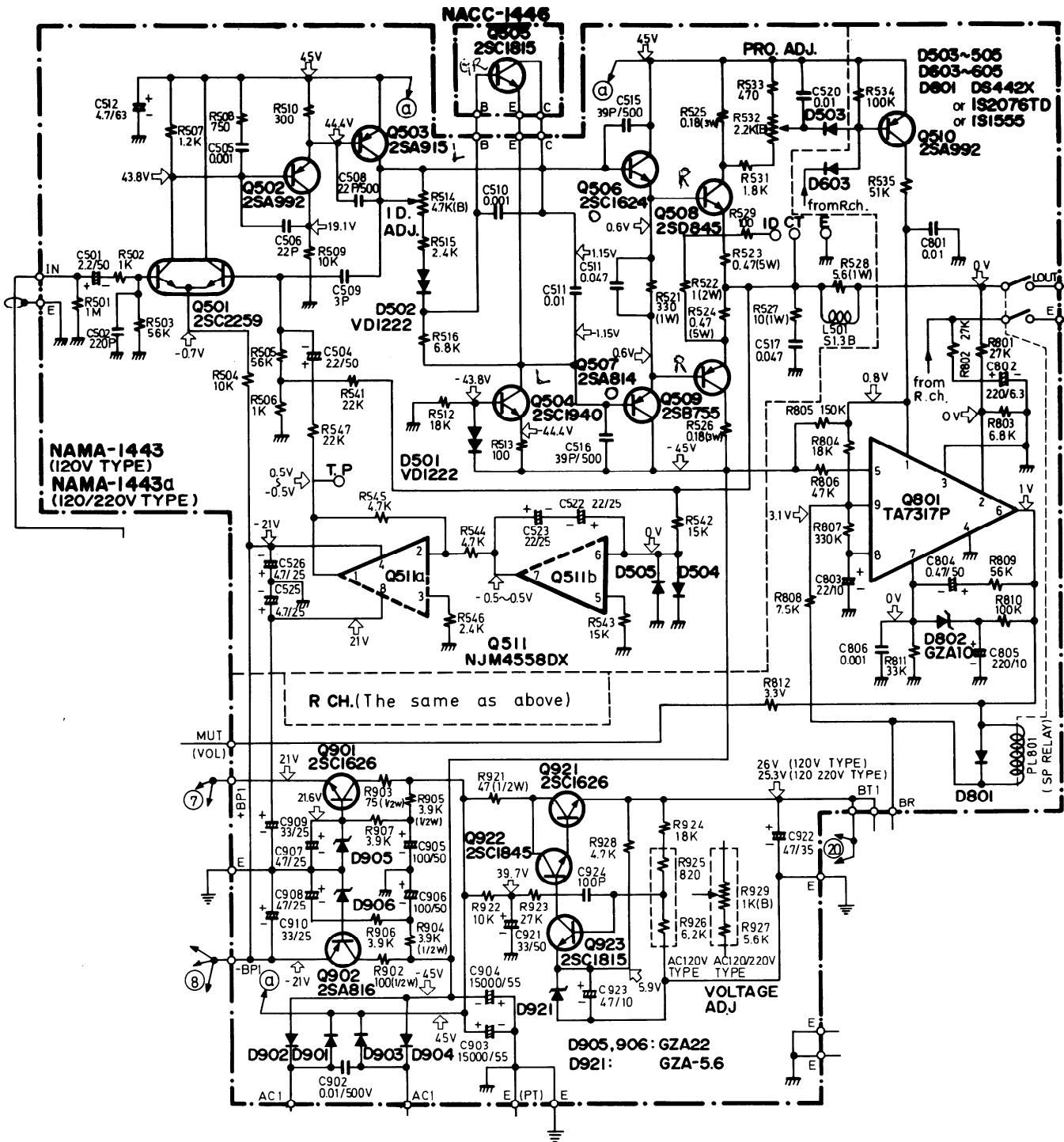

### TA7317P (Protection Circuit)

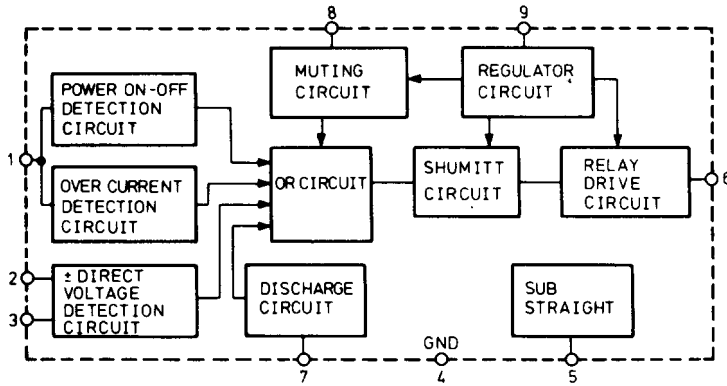

### NJM-4558DX (Super servo amplifier)

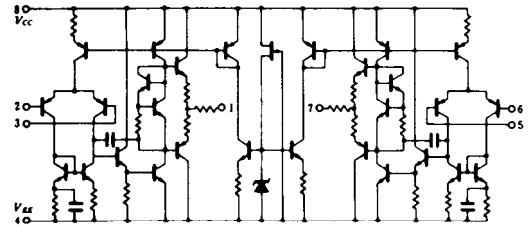

1.7 Output  
2.6 Inverse input  
3.5 Input

### POWER AMPLI., PROTECTOR AND POWER SUPPLY PC BOARD (NAMA-1443)

CIRCUIT NO.	PARTS NO.	DESCRIPTION	CIRCUIT NO.	PARTS NO.	DESCRIPTION
Q511, Q611	222502	NJM-4558DX	C501, C601	352780229	2.2μF, 50V, Elect.
Q801	222584	TA7317P, Protector	C504, C604	352780229	2.2μF, 50V, Elect.
	<b>Transistors</b>		C512, C612	352770479	4.7μF, 63V, Elect.
Q501, Q601	2211371 or 2211372	2SC2259 (F) or 2SC2259 (G)	C522, C622	352752209	22μF, 25V, Elect.
Q502, Q602	2211792 or 2211793	2SA992 (F) or 2SA992 (E)	C523, C623	352752209	22μF, 25V, Elect.
Q503, Q603	2211742	2SA915(L)	C524, C525	352750479	4.7μF, 25V, Elect.
Q504, Q604	2211762	2SC1940 (L)	C624, C625	352750479	4.7μF, 25V, Elect.
Q506, Q606	2201174 or 2201173	2SC1624 (Y) or 2SC1624 (O)	C802	352721019	100μF, 6.3V, Elect.
Q507, Q607	2201184 or 2201183	2SA814 (Y) or 2SA814 (O)	C803	352732209	22μF, 10V, Elect.
CAUTION : When replace the transistors Q506, Q507, Q606 and Q607, if necessary, use the same hFE (Beta) rank transistor.			C804	352784799	0.47μF, 50V, Elect.
(Q508, Q608)	2201103 or 2201102	2SD845 (O) or 2SD845 (R)	C805	352742219	220μF, 16V, Elect.
(Q509, Q609)	2201093 or 2201092	2SB755 (O) or 2SB755 (R)	C903, C904	3504161	15,000μF, 55V, Elect.
When replace the power amplifier transistor Q508, Q509, Q608 and Q609, if necessary, use the same hFE (Beta) transistor.			C905, C906	352781019	100μF, 50V, Elect.
Q510	2211792 or 2211793	2SA992 (F) or 2SA992 (E)	C907, C908	352754709	47μF, 25V, Elect.
Q901	2200664 or 2200663	2SC1626 (Y) or 2SC1626 (O)	C909, C910	342753309	33μF, 25V, Elect.
Q902	2200674 or 2200673	2SA816 (Y) or 2SA816 (O)	C921	352783309	33μF, 50V, Elect.
Q921	2200663 or 2200664	2SC1626 (O) or 2SC1626 (Y)	C922	352764709	47μF, 35V, Elect.
Q922	2211732 or 2211733	2SC1845 (F) or 2SC1845 (E)	C923	352734709	47μF, 10V, Elect.
Q923	2211255 or 2211256	2SC1815 (GR) or 2SC1815 (BL)		<b>Resistors</b>	
D501, D502	4000068	VD1222	R514, R614	5225072	N10HR4.7KBDM, Semi-fixed
D601, D602	4000068	VD1222	R521, R621	441623314	330Ω, 1W, Metal oxide film
D503-D505	223133,	DS442X,	R522, R622	441720104	1Ω, 2W, Metal oxide film
D603-D605	223145 or 223105	1S2076TD or 1S1555	R523, R623	4000080	0.47Ω, 5W, Metal plate
D801	223133	DS442X	R524, R624	4000080	0.47Ω, 5W, Metal plate
D802	2241072 or 2241073	GZA-10Y or GZA-10Z	R525, R625	4000070	0.18Ω, 3W, Metal plate
D901-D904	223863	GP30DL	R526, R626	4000070	0.18Ω, 3W, Metal plate
D905, D906	2241231 or 2241232	GZA-22X or GZA-22Y	R527, R627	441621004	10Ω, 1W, Metal oxide film
D921	2240953	GZA-5.6Z	R528, R628	441620564	5.6Ω, 1W, Metal oxide film
L501, L502	231001	S-1.3B	R532, R632	5225005	N10HR2.2KBD, Semi-fixed
			R902	442521014	100Ω, 1/2W, Metal oxide film
			R903	442527504	75Ω, 1/2W, Metal oxide film
			R904, R905	441523924	3.9kΩ, 1/2W, Metal oxide film
			R921	442524704	47Ω, 1/2W, Metal oxide film
			R929	5225014	N10HR1KBDM, Semi-fixed [W]
				<b>Relay</b>	
			RL801	25065134	NRL-2P-5A-DC24V-07
				<b>Radiator</b>	
				27160029	RAD-07
				<b>Screws</b>	
				82113008	3P + 8FN, Pan head

### THERMAL DETECTOR PC BOARD (NACC-1446)

CIRCUIT NO.	PARTS NO.	DESCRIPTION
Q05	2211255 or 2211256	2SC1815 (GR) or 2SC1815 (BL)

Note : D : Only 120V model  
W : Only 120/220V model

**Thermal detector pc board**

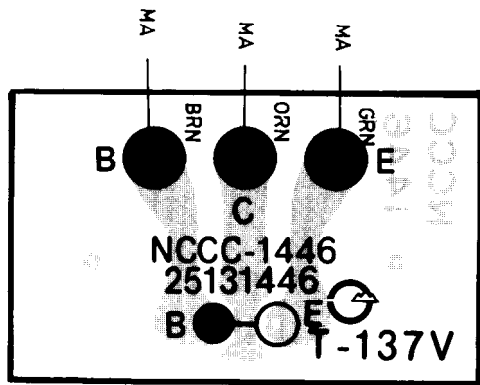

**Speaker switch connection diagram**

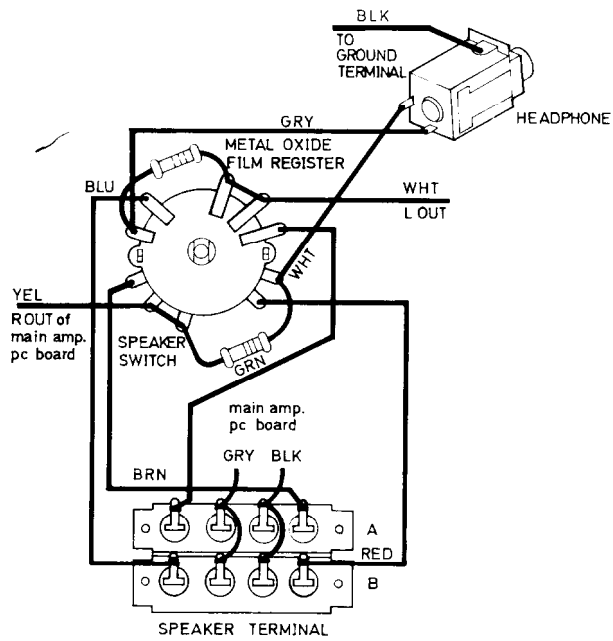

**Power supply circuit connection diagram**

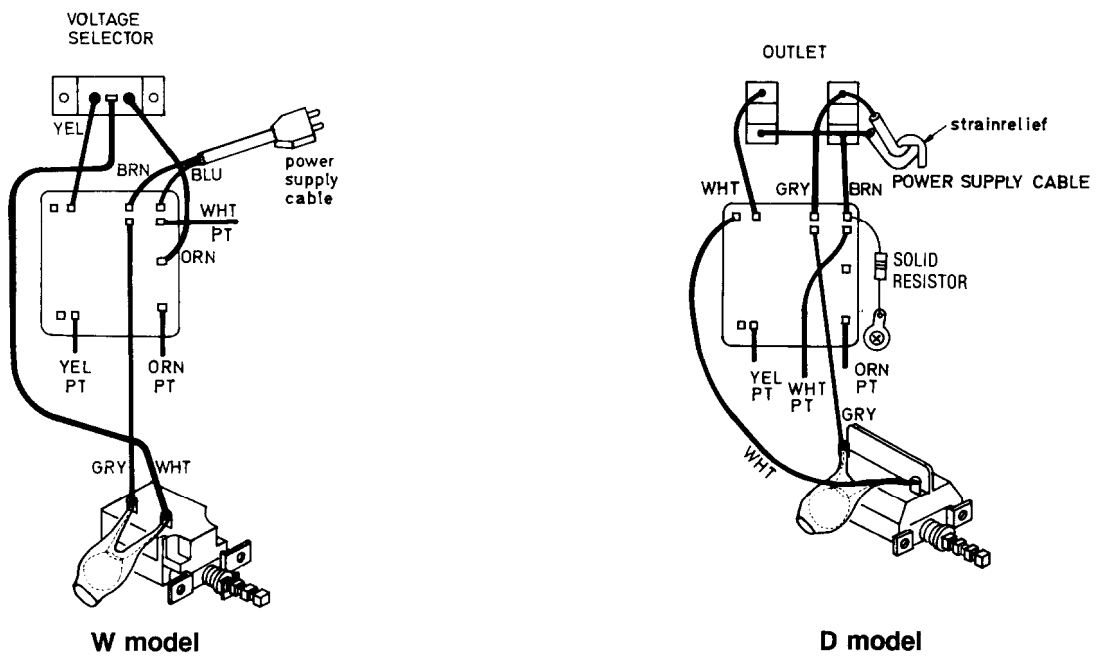



# PACKING VIEW

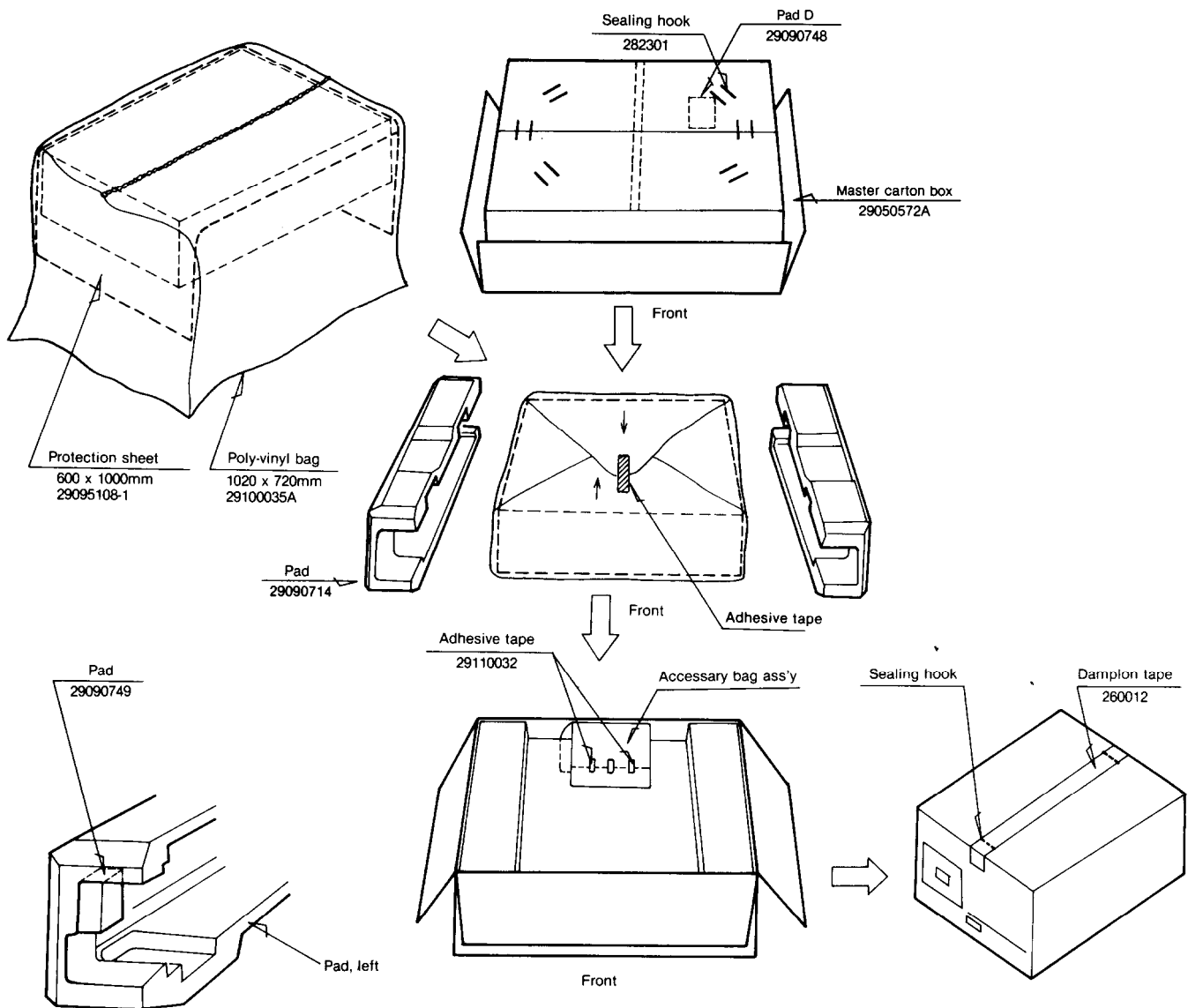

## PARTS NO. DESCRIPTION

### Accessory bag ass'y (U.S.A. model)

29340624	Instruction manual
292064A	FM antenna
29365006-4	Warranty card
29358002	Service station list
29100006	250x350mm, Poly-vinyl bag
3010054	Battery

## PARTS NO. DESCRIPTION

### (120V model)

29340624	Instruction manual
292064A	FM antenna
29100006	250x350mm, Poly-vinyl bag
3010054	Battery

### (120/220V model)

29340624	Instruction manual
292064A	FM antenna
25055018	CV-K-2, Conversion plug
2910006	250x350mm, Poly-vinyl bag