

ONKYO[®] SERVICE MANUAL

QUARTZ SYNTHESIZED TUNER AMPLIFIER MODEL TX-7430



SAFETY-RELATED COMPONENT WARNING!!

COMPONENTS IDENTIFIED BY MARK  ON THE SCHEMATIC DIAGRAM AND IN THE PARTS LIST ARE CRITICAL FOR RISK OF FIRE AND ELECTRIC SHOCK. REPLACE THESE COMPONENTS WITH ONKYO PARTS WHOSE PARTS NUMBERS APPEAR AS SHOWN IN THIS MANUAL.

MAKE LEAKAGE-CURRENT OR RESISTANCE MEASUREMENTS TO DETERMINE THAT EXPOSED PARTS ARE ACCEPTABLY INSULATED FROM THE SUPPLY CIRCUIT BEFORE RETURNING THE APPLIANCE TO THE CUSTOMER.

TABLE OF CONTENTS

- Specifications 2
- Service procedures 3
- Exploded view 4
- Parts list 5
- Circuit descriptions 6
- Block diagram – Amp. section – 12
 - Tuner section – 13
- Block diagram of IC 14
- Packing view 17
- Adjustment procedures 18
- Pc board view/parts list
 - Power amp. 21
 - FM/AM tuner 25
 - Display 29
 - Preamp. 30
 - Remote control 31
 - Switch 31
 - Speaker 32
 - Volume 32
- Schematic diagram
 - Amp. section 23
 - Tuner section 27
- Disassembling procedures 33



SPECIFICATIONS

AMPLIFIER SECTION

Power Output:	45 watts per channel, min. RMS, at 8 ohms, both channels driven, from 20Hz to 20kHz, with no more than 0.08% THD.
Musical Power Output:	2 x 126 watts at 4 ohms, 1kHz (DIN) 2 x 78 watts at 8 ohms, 1kHz (DIN)
Continuous Power Output:	2 x 70 watts at 4 ohms, 1kHz (DIN) 2 x 55 watts at 8 ohms, 1kHz (DIN)
Total Harmonic Distortion:	0.08% at rated power 0.08% at 1 watt output
IM Distortion:	0.08% at rated power 0.08% at 1 watt output
Damping Factor:	35 at 8 ohms
Frequency Response:	20 - 30,000 Hz \pm 1dB
RIAA Deviation:	20 - 20,000 Hz \pm 0.8dB
Sensitivity and Impedance:	Phono: 2.5mV/50 kohms CD/Tape Play: 150mV/50 kohms Tape Rec: 150mV/3.5 kohms (phono)
Phono Overload:	120mV RMS at 1kHz, 0.08% THD
Signal-to-Noise Ratio:	Phono: 85dB (at 10mV input, A weighted) 75dB (IHF A-202) CD/Tape: 95dB (A weighted) 80dB (IHF A-202)
Tone Controls:	Bass: \pm 10dB at 100Hz Treble: \pm 10dB at 10kHz
Muting:	-20dB

TUNER SECTION

FM:	
Tuning Range:	87.5 - 108.0MHz (50kHz steps)
Usable Sensitivity:	Mono: 12.8dBf, 1.2 μ V, 75 ohms 1.0 μ V (S/N 26dB, 40kHz Devi.) 75 ohms DIN Stereo: 18.0dBf, 2.2 μ V, 75 ohms 23 μ V(S/N 46dB, 40kHz Devi.) 75 ohms DIN
50dB Quieting Sensitivity:	Mono: 18.0dBf, 2.2 μ V, 75 ohms Stereo: 37.2dBf, 20 μ V, 75 ohms
Capture Ratio:	1.5dB
Image Rejection Ratio:	85dB
IF Rejection Ratio:	90dB
Signal-to-Noise Ratio:	Mono: 72dB Stereo: 66dB
Selectivity	50dB DIN (\pm 300kHz, 40kHz dev.)
AM Suppression Ratio:	50dB
Harmonic Distortion:	Mono: 0.15% Stereo: 0.30%
Frequency Response:	30 - 15,000Hz \pm 1.5dB
Stereo Separation:	45dB at 1kHz 30dB at 100 - 10,000Hz
AM:	
Tuning Range:	522 - 1611kHz (9kHz steps)
Usable Sensitivity:	30 μ V
Image Rejection Ratio:	40dB
IF Rejection Ratio:	40dB
Signal-to-Noise Ratio:	40dB
Harmonic Distortion:	0.7%

GENERAL

Dimensions (W x H x D):	435 x 110 x 345 mm 17-1/8" x 4-3/8" x 13-1/2"
Weight:	7.5 kg., 16.5 lbs.

Specifications and features are subject to change without notice.

Remote Control transmitter RC-82S

Transmitter: Infrared
 Signal range: Approx. 5 meters (16ft. 4")
 Power supply: Two "AA" batteries (1.5V x 2)
 Dimensions (W x H x D): 64 x 18 x 149 mm
 2-1/2" x 11/16" x 5-7/8"
 Weight: 110 grams 3.9 oz. (including batteries)

SERVICE PROCEDURES**1. Replacing the fuses**

For continued protection against fire hazard, replace only with same type and same rating fuse.

Circuit no.	Part no.	Description
F902	252075	2.5A-SE-EAK, Primary
F903, F904	252078	5A-SE-EAK, Secondary
F905	252070	1A-SE-EAK, Secondary

2. Change of FM/AM band step.

This model is not located the band selector switch.

If the FM band step is changed from 50kHz to 200kHz, remove two diodes (1SS133) to D709 and D710 on the display PC board.

If the AM band step is changed from 9kHz to 10kHz, remove a diode (1SS133) to D711 on the display PC board.

3. Memory preservation

This unit does not require memory preservation batteries.

A built-in memory power back-up system preserves contents of the memory during power failures and even when the unit is unplugged. The unit must be plugged in and the power switch turned on and off once in order to charge the back-up system. Note that since this is not a permanent memory, the power switch must be turned on and off a few times each month to keep the back-up system operative. The period of time during which memory contents are preserved after power has last been turned off varies depending on climate and placement of the unit.

On the average, memory contents are protected over a period of 3 to 4 weeks (a minimum of 2 weeks) after the last time power has been turned off. This period is shorter when the unit is exposed to very high humidity or used in an area with an extremely humid climate.

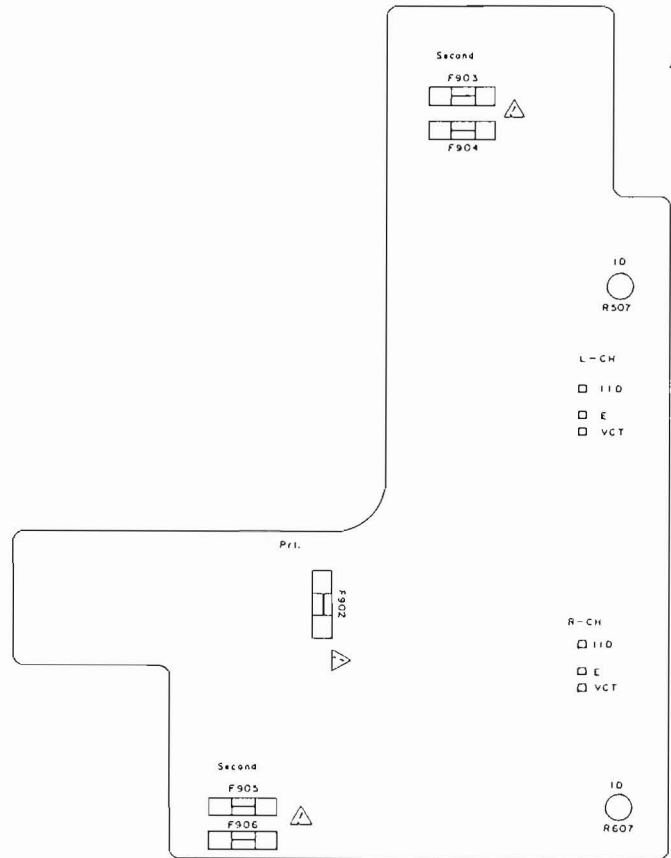

EXPLODED VIEW

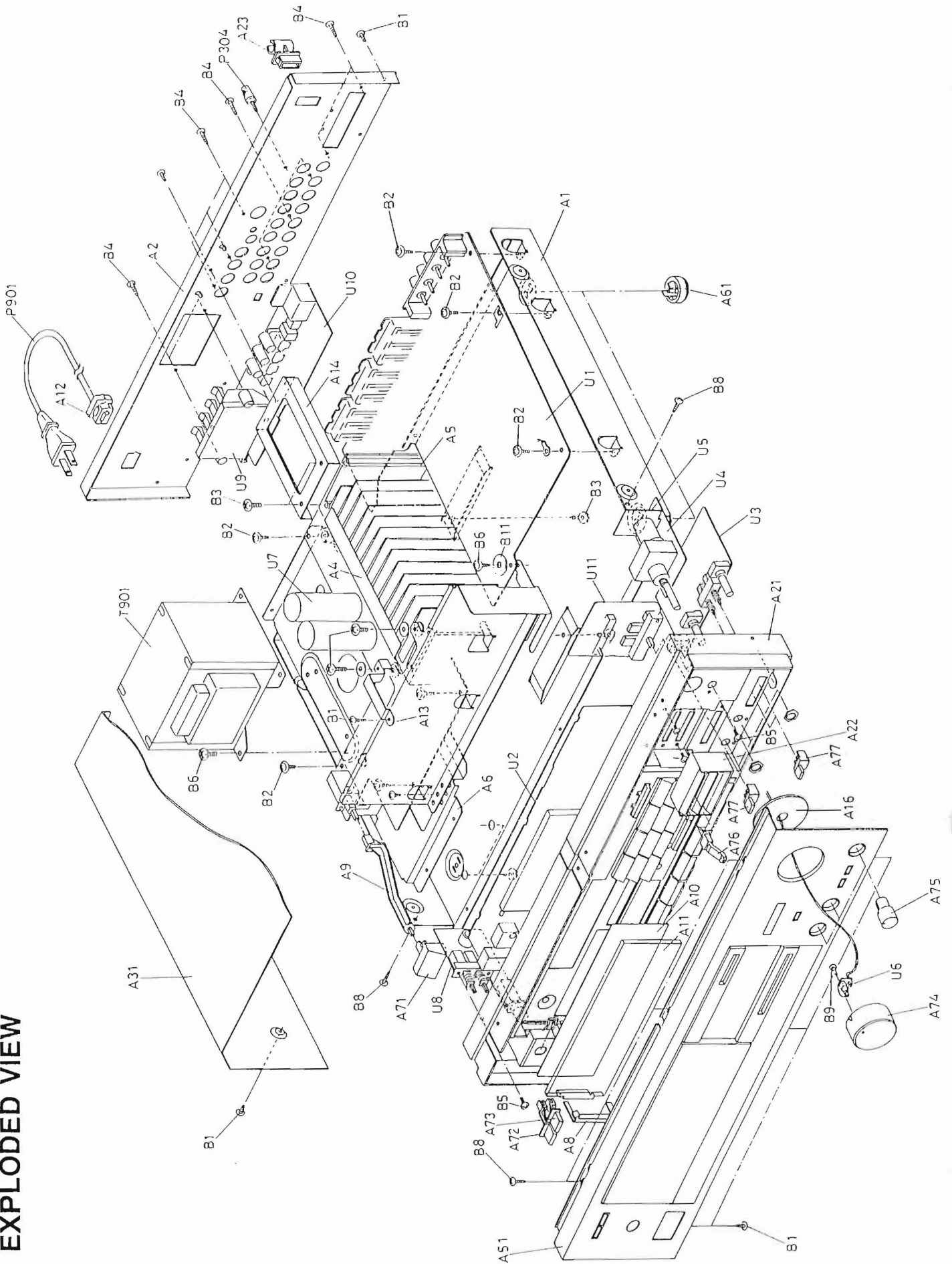

PARTS LIST

REF.NO.	PART NO.	DESCRIPTION
A1	27100121A	Chassis
A2	27120943A	Back panel
A3	27130470	Bracket, shielded
A4	27130468A	Bracket, radiator
A5	27160201	Radiator
A6	27130469A	Bracket, power transformer
A8	27190359A	Holder, dial plate
A9	27273030C	Joint L
A10	28133176A	Back plate
A11	28130242A	Dial plate
A12	27300750	△ Strainrelief
A13	27141122	Bracket F
A14	27141123A	Bracket R
A15	27270216	Spacer
A21	27110338B	Front bracket ass'y <S>
	27110339B	Front bracket ass'y
A22	27190525	Holder, slider <S>
	27190526	Holder, slider
A23	27190105	Holder, antenna
A31	28184356A	Top cover <S>
	28184357A	Top cover
A51	1A001121	Front panel ass'y <S>
	1A010121	Front panel ass'y
A52	28140220	Cushion
A61	27175130	Leg
A71	28322796	Knob, Power <S>
	28322795A	Knob, Power
A72	28322469	Knob, Speaker A <S>
	28322304-1	Knob, Speaker A
A73	28322470	Knob, Speaker B <S>
	28322305-1	Knob, Speaker B
A74	28322922B	Knob, Volume <S>
	28322923B	Knob, Volume
A75	28322928	Knob, Tone <S>
	28322929	Knob, Tone
A76	28322924	Knob, Slide <S>
	28322925	Knob, Slide
A77	28322926A	Knob, Push <S>
	28322927A	Knob, Push
B1	834430068	3TTS+6B(BC), Tapping screw
B2	831130088	3TTW+8B, Tapping screw
B3	838440089	4TTB+8C(BC), Tapping screw
B4	834430108	3TTS+10B(BC), Tapping screw
B5	82143006	3P+6FN(BC), Pan head screw
B6	830440089	4TTC+8C(BC), Tapping screw
B7	82142004	2P+4F(BC), Pan head screw
B8	833430080	3TTP+8P(BC), Tapping screw
B9	880011	Rivet
B10	830440109	4TTC+10C(BC), Tapping screw

REF.NO.	PART NO.	DESCRIPTION
B11	870060	Flat washer
F902	252074	△ 2A-SE-EAK, Fuse, primary
F903, F904	252078	△ 5A-SE-EAK, Fuse, secondary
F905, F906	252070	△ 1A-SE-EAK, Fuse, secondary
P304	25060044	Terminal GND
P901	253128B or 253130A	△ AS-CEE, Power supply cord
Q508, Q608	2201783, 2201784 or 2201786	2SC3854(O), 2SC3854(Y) or 2SC3854(P)
Q509, Q609	2201773, 2201774 or 2201776	2SA1490(O), 2SA1490(Y) or 2SA1490(P)
Q902, Q905	2201754, 2201755, 2201404 or 2201405	2SD1913(R), 2SD1913(S), 2SD1406(Y) or 2SD1406(GR)
T901	2300199	△ NPT-955G, Power transformer
U1	1A008569-2A	NAAR-2869-2A, FM/AM tuner pc board ass'y
U2	1A008570-2A	NAD1S-2870-2A, Display pc board ass'y
U3	1A008571-2A	NAAF-2871-2A, Preampifier pc board ass'y
U4	1A013572-1	NAAF-2872-1, Volume pc board ass'y
U5	1A013573-1	NAETC-2873-1, Volume motor pc board ass'y
U6	1A013574-1	NAD1S-2874-1, Volume indicator pc board ass'y
U7	1A008575-2A	NAPS-2875-2A, Power amplifier and power supply pc board ass'y
U8	1A013576-1A	NASW-2876-1A, Speaker switch pc board ass'y
U9	1A013577-1A	NAETC-2877-1A, Speaker terminal pc board ass'y
U10	1A008578-2	NAETC-2878-2, Remote control terminal pc board ass'y
U11	1A008579-2	NAAF-2879-2, Switch pc board ass'y

NOTE: : Only Black model
<S>: Only Silver model

NOTE: THE COMPONENTS IDENTIFIED BY MARK △ ARE
CRITICAL FOR RISK OF FIRE AND ELECTRIC
SHOCK. REPLACE ONLY WITH PART NUMBERS
SPECIFIED.

CIRCUIT DESCRIPTIONS

1: Remote control decoder (LM6405G)

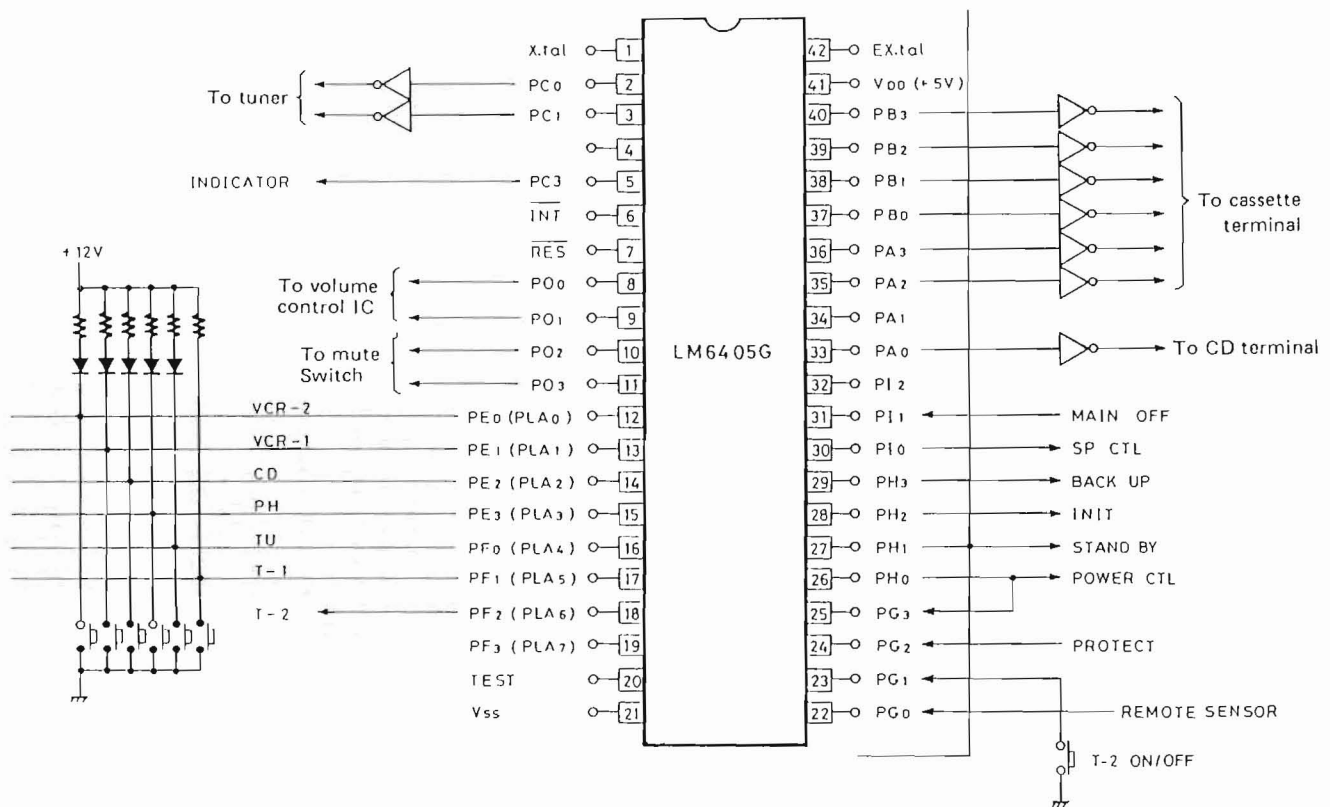

Pin No.	Code	Description
1	X'tal	Ceramic resonator
2	ST. UP	Preset STATION UP signal output terminal Output "L" during pushing of remote control STATION UP KEY
3	ST. DN	Preset STATION DOWN signal output terminal Output "L" during pushing of remote control STATION DOWN KEY
5	INDI	Terminal for indicating Light received by remote control; during light reception, "L" is output
7	RES	Reset terminal
8	VOL. UP	VOLUME UP signal output terminal Outputs "L" during pushing of VOLUME UP KEY
9	VOL. DN	VOLUME DOWN signal output terminal Output "L" during pushing of VOLUME DOWN KEY
10	MUTING	MUTING ON/OFF output terminal Switching of "L" ↔ "H" (ON = "H") by means of remote control AUDIO MUTING KEY

Pin No.	Code	Description
11	MUT-2	Muting signal output terminal for TAPE-2 change-over "H" during 200mS change-over time to TAPE-2
12	VCR-2	Selector signal output terminal for VCR-2 change-over "L" during 200mS after pushing remote control VCR-2 KEY
13	VCR-1	Selector signal output terminal for VCR-1 change-over "L" during 200mS after pushing remote control VCR-1 KEY
14	CD	Selector CD change-over signal output terminal "L" during 200mS after pushing remote control CD KEY
15	PH	Selector PHONO change-over signal output terminal "L" during 200mS after pushing remote control PHONO KEY
16	TU	Selector signal output terminal for TUNER change-over "L" during 200mS after pushing remote control TUNER KEY
17	T-1	Selector signal output terminal for TAPE-1 change-over "L" during 200mS after pushing remote control TAPE-1 KEY
18	T-2	Selector signal output terminal for TAPE-1 change-over Switching of "H" ↔ "L" by means of remote control TAPE-2 KEY
21	GND	GND terminal
22	REM IN	Remote control signal input terminal
23	T-2 CTL	TAPE-2 ON/OFF control input terminal T-2 output is changed-over with "L" input
24	PROTECT	Protection function input terminal; with "H" input, output SP CTL "H"
25	CONT IN	Power source condition input terminal; connects to POWER output; POWER ON with "H"
26	POWER	Power source control output terminal Switching of "H" ↔ "L" (ON = "H")
27	STBY	Terminal for indication during STANDBY; POWER reversing output
28	INIT	Output terminal for start of selector "L" during 300mS when power source is ON
29	B. UP	Output terminal for back up during STANDBY
30	SP CTL	Speaker control output terminal ("L" = speaker output ON)
31	M. OFF	Main power source OFF detection terminal
33	CD MODE	Serial signal output terminal for CD control use
35	REW	Cassette deck control signal output terminal "H" during 200mS after pushing remote control REW KEY
36	FF	Cassette deck control signal output terminal "H" during 200mS after pushing remote control FF KEY
37	REC	Cassette deck control signal output terminal "H" during 200mS after pushing remote control REC KEY
38	STOP	Cassette deck control signal output terminal "H" during pushing of remote control STOP KEY
39	PAUSE	Cassette deck control signal output terminal "H" during 200mS after pushing remote control PAUSE KEY
40	PLAY	Cassette deck control signal output terminal "H" during 200mS after pushing remote control PLAY KEY
41	V _{DD}	Power source terminal
42	Extal	Ceramic resonator connection terminal

2. Controller connection

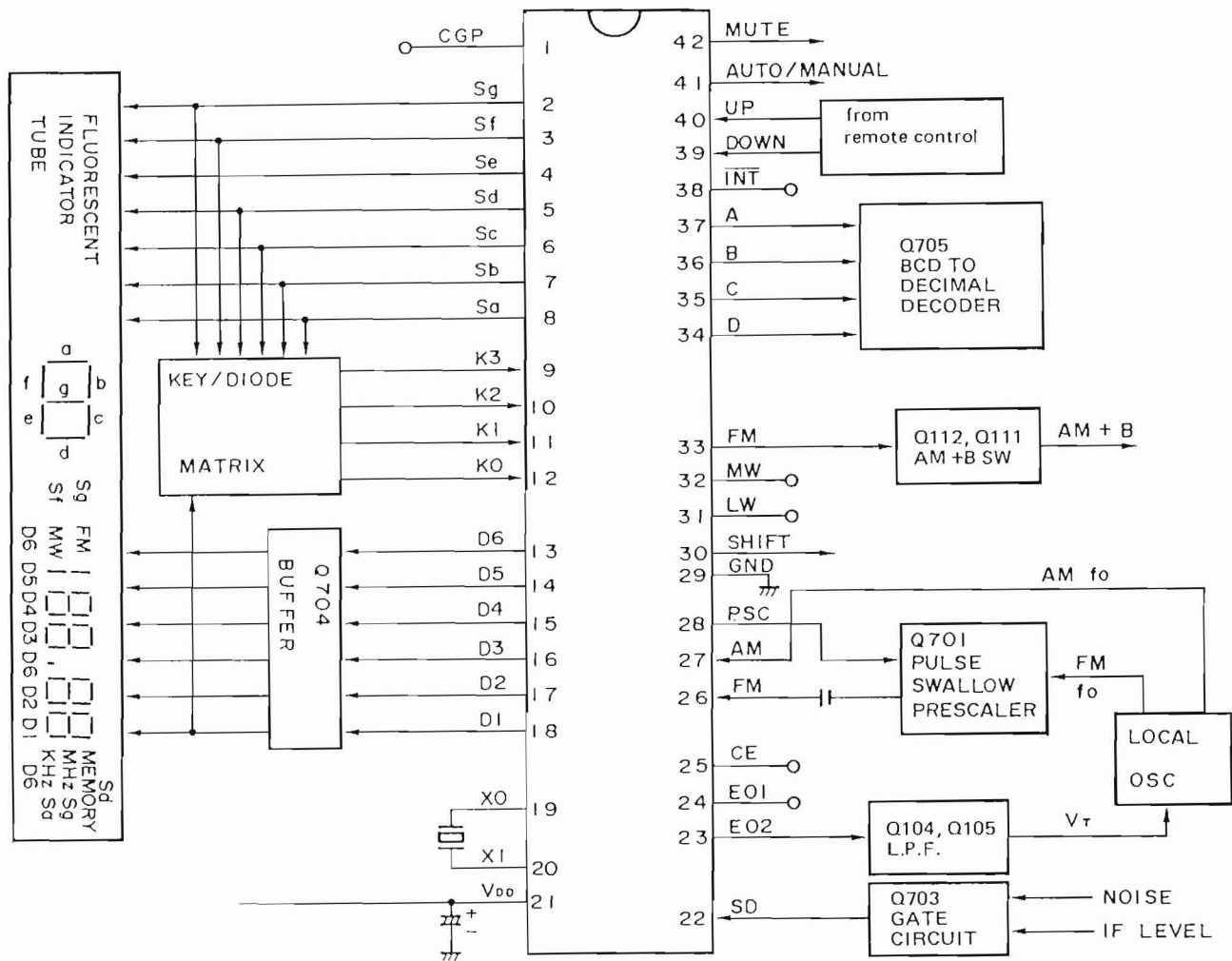

Pin No.	Symbol	Terminal	Description
1	CGP		Output terminal for sound "PEE".
2 - 8	Sa - Sg	Segment outputs	Display tube signal terminal output and key return signal source terminals; active high. Since these terminals can handle 30V, they are connected directly to the segment terminals of the fluorescent display tube.
9 - 12	K0 - K3	Key return signal inputs	Terminals for input of the key return signals from external matrix circuit.
13 - 18	D1 - D6	Digit outputs	Display tube digit output signal terminals; active low. D1 is used the key return signal source to diode matrix.
19, 20	X1, X2	X'tal	Connect to the 4.5MHz crystal oscillator.
21	V _{DD}	Power source input	Device power source terminal; supplies 5V during normal operation and 2.5V from the super capacitor C714 for memory preservation.

Pin No.	Symbol	Terminal	Description																																													
22	SD	Station detector signal input	Input terminal for detecting whether or not a broadcast signal is being received during auto-tuning. Stopped by the high level.																																													
23, 24	E01, E02	Error outputs	Charge pump output of the phase detector with constitutes the PLL. High level is output when the divided oscillation frequency is higher than the reference frequency. In the opposite case, low level is output. Floating occurs when the frequencies match. The output is applied to the variable capacitor diode in the front end through the low pass filter Q104 and Q105. The output from both terminals is same, but only E02 is used.																																													
25	CE	Chip enable	Device selection signal input terminal. High level ... Normal operation Low level ... Memory preservation																																													
26	FM	FM local oscillator signal input	Input terminal for FM local oscillator is divided by 1/16 or 1/17 by prescaler Q701.																																													
27	AM	AM local oscillator signal input	Terminal for input of the AM local oscillator signal.																																													
28	PSC	Pulse swallow control output	This terminal outputs a signal that switches the prescaler division ratio of Q701 to 1/16 or 1/17 when the pulse swallow method is used for division. (FM only)																																													
29	GND	Ground																																														
30	SHIFT	Preset reverse indication output	Terminal for indication output whether M1 – M8 or M9 – M16 the preset key. M1 – M8: Low level M9 – M16: High level																																													
31	LW	Band switching signal outputs	Terminals for signal output switching of each band. High level is output from terminal of FM (pin no. 33) and low level is output from other terminals (pin no. 31 & 32) during FM reception.																																													
32	MW																																															
33	FM																																															
34 35 36 37	A B C D	Preset station indication outputs	Terminals for BCD code output of preset station indicator. <table style="margin-left: 40px; border-collapse: collapse;"> <thead> <tr> <th></th> <th>M1</th> <th>M2</th> <th>M3</th> <th>M4</th> <th>M5</th> <th>M6</th> <th>M7</th> <th>M8</th> </tr> </thead> <tbody> <tr> <td>A</td> <td>1</td> <td>0</td> <td>1</td> <td>0</td> <td>1</td> <td>0</td> <td>1</td> <td>0</td> </tr> <tr> <td>B</td> <td>0</td> <td>1</td> <td>1</td> <td>0</td> <td>0</td> <td>1</td> <td>1</td> <td>0</td> </tr> <tr> <td>C</td> <td>0</td> <td>0</td> <td>0</td> <td>1</td> <td>1</td> <td>1</td> <td>1</td> <td>0</td> </tr> <tr> <td>D</td> <td>0</td> <td>0</td> <td>0</td> <td>0</td> <td>0</td> <td>0</td> <td>0</td> <td>1</td> </tr> </tbody> </table>		M1	M2	M3	M4	M5	M6	M7	M8	A	1	0	1	0	1	0	1	0	B	0	1	1	0	0	1	1	0	C	0	0	0	1	1	1	1	0	D	0	0	0	0	0	0	0	1
	M1	M2	M3	M4	M5	M6	M7	M8																																								
A	1	0	1	0	1	0	1	0																																								
B	0	1	1	0	0	1	1	0																																								
C	0	0	0	1	1	1	1	0																																								
D	0	0	0	0	0	0	0	1																																								
38	INT		Not used.																																													
39	MEMORY	Memory down input	Terminal for down signal input of preset memory. Active low.																																													
40	MEMORY UP	Memory up input	Terminal for up signal input of preset memory. Active low.																																													
41	AUTO/ MANUAL	Auto/Manual indication output	Terminal for indication output whether or auto the tuning mode. This terminal becomes high during auto mode and low during manual mode.																																													
42	MUTE	Muting output	Output terminal which mutes the shock noise occurring when the PLL is released; active high. The muting signal is output as shown below. UP/DOWN of manual/auto mode, preset memory is recalled, band switching and preset scan.																																													

Control key and diode matrix connections

	K3(9)	K2(10)	K1(11)	K0(12)
Sg(2)	M4/M14	M3/M13	M2/M12	M1/M11
Sf(3)	M8/M18	M7/M17	M6/M16	M5/M15
Se(4)		PRESET SCAN	M10/M20	M3/M19
Sd(5)	SHIFT	LW	MW	FM
Sc(6)	AUTO MANUAL	MEMORY	DOWN	UP
Sb(7)	HI-BLEND	DISPLAY	PROGRAM	WIDE/ NARROW
Sa(8)	*10/9kHz	*LW2	*LW1	*AM
D1(18)	*BAND 0	*BAND 1	*10/8	STATIC/ DYNA

*Diode matrix

table 1

BAND0	BAND1	REGION	FREQUENCY RANGE	CHANNEL SPACE
D710	D709			
0	0	U.S.A.	87.9-107.9MHz	200kHz
1	1	Europe	87.50-108.00MHz	50kHz

0: Open 1: Connect the diode (ISS133).

table 2

AM	10kHz/9kHz	FREQUENCY RANGE	CHANNEL SPACE
	D711		
0	0	530-1620kHz	10kHz
0	1	522-1611kHz	9kHz
1	0	531-1602kHz	9kHz

0: Open 1: Connect the diode (ISS133).

table 3

BAND0, BAND1 FM band settings. See table 2.
10/9kHz AM band settings. See table 3.

3. Muting circuit

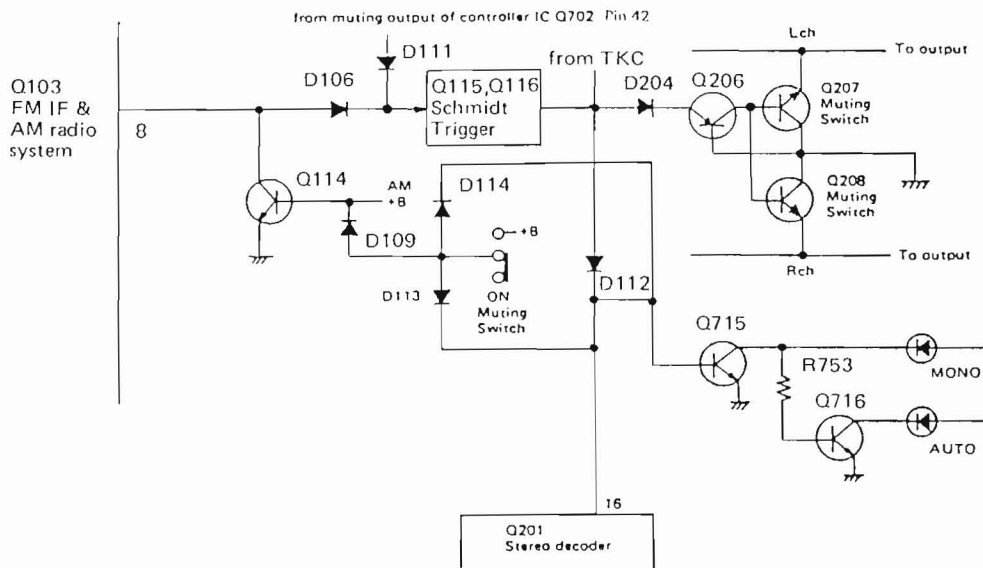

The muting circuit operates in the following cases.

- While pin 42 of controller IC outputs the high level. Q207 and Q208 are turned on and muting is closed in the following cases: (1) While the manual UP/DOWN switch is being held down, (2) When a station in the memory is recalled, and (3) While a radio station is being received using auto search tuning.
- When an FM station is not being received (and the muting switch is on). The IF level in the FM IF system (set at R101 so muting

is opened at 17.2dBf and zero-cross detection circuit (tuning point 55kHz (100kHz step): 30kHz (50kHz step) -are output at pin 8 through the AND circuit. When a station is turned, the output goes to the low level. When output goes to the low level, Q115 turned off, Q116 is turned on and Q207 and Q208 are turned off, so muting is opened. At the same, pin 16 of stereo decoder Q201 goes to the low level, so the VCO oscillator starts.

4. PLL tuned circuit

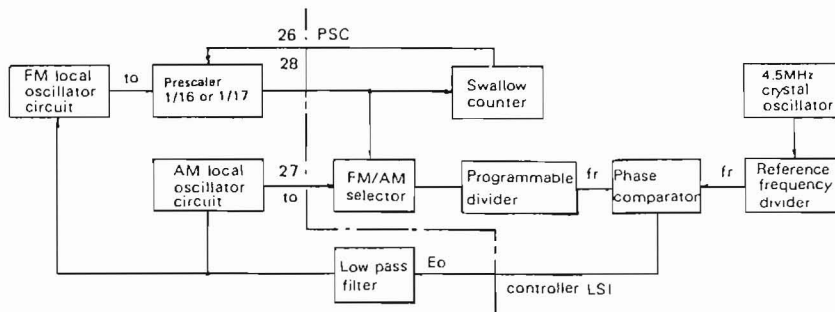

A block diagram of the tuned of the PLL is shown in the above diagram.

Operation during AM reception

The reception frequency is applied to the programmable divider where it is divided to $1/N$ and output as f_v . This is applied to the phase comparator where it is compared with frequency reference f_r (9kHz for G/W models and 10kHz for D model). If f_r and f_v differ, E_o equal to the difference in frequency is output. Since error output E_o is a pulse waveform, it is passed through the low pass filter to change it into DC voltage V_d , which is applied to the variable capacitor diode in the front end to change the reception frequency. This continues until f_v and f_r are the same and $E_o=0$.

Operation during FM reception

The pulse swallow method is used in the prescaler of this unit. In this type of prescaler, a supplementary number

(changed according to the program code input) and the divided reception frequency from the prescaler are combined in the control counter and the prescaler's division factor is switched 1/16 or 1/17 according to external control (1/16 when the PSC terminal is "H" and 1/17 when it is "L").

The station oscillator frequency is applied to the programmable divider, but the programmable divider has an upper frequency limit of only 30MHz, so the pulse swallow-type prescaler, which can be used up to 150MHz, is inserted for division to $1/N_p$;

The signal is applied to the programmable divider and divided to $1/N$. The result is compared with a 25kHz frequency reference in the phase detector and error is output as E_o until a match is obtained as in AM operation.

5. Auto search tuning circuit

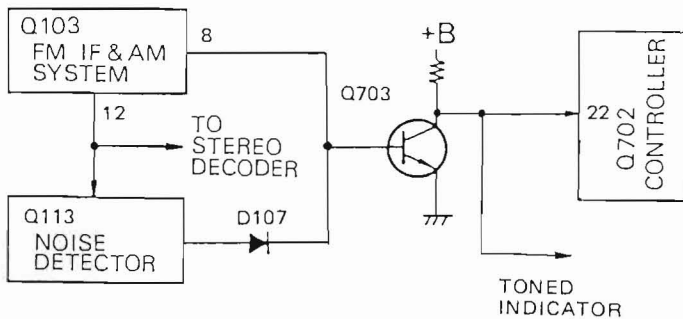

During FM reception, this is operated by the IF level detection and zero cross detection circuits included in the FM IF & AM system IC of Q103 and by the noise component detection circuit of Q113. When a station is tuned, the output of all outputs go to the low level so Q703 goes from on to off, causing pin 22 of the controller IC to go to the high level to complete auto search tuning.

During AM reception, this is operated by the IF level detection included in the FM IF & AM system IC of Q103. When a station is tuned, Q703 goes to off, causing pin 22 of the controller IC to go to the high level to complete auto search tuning.

BLOCK DIAGRAM — AMPLIFIER SECTION —

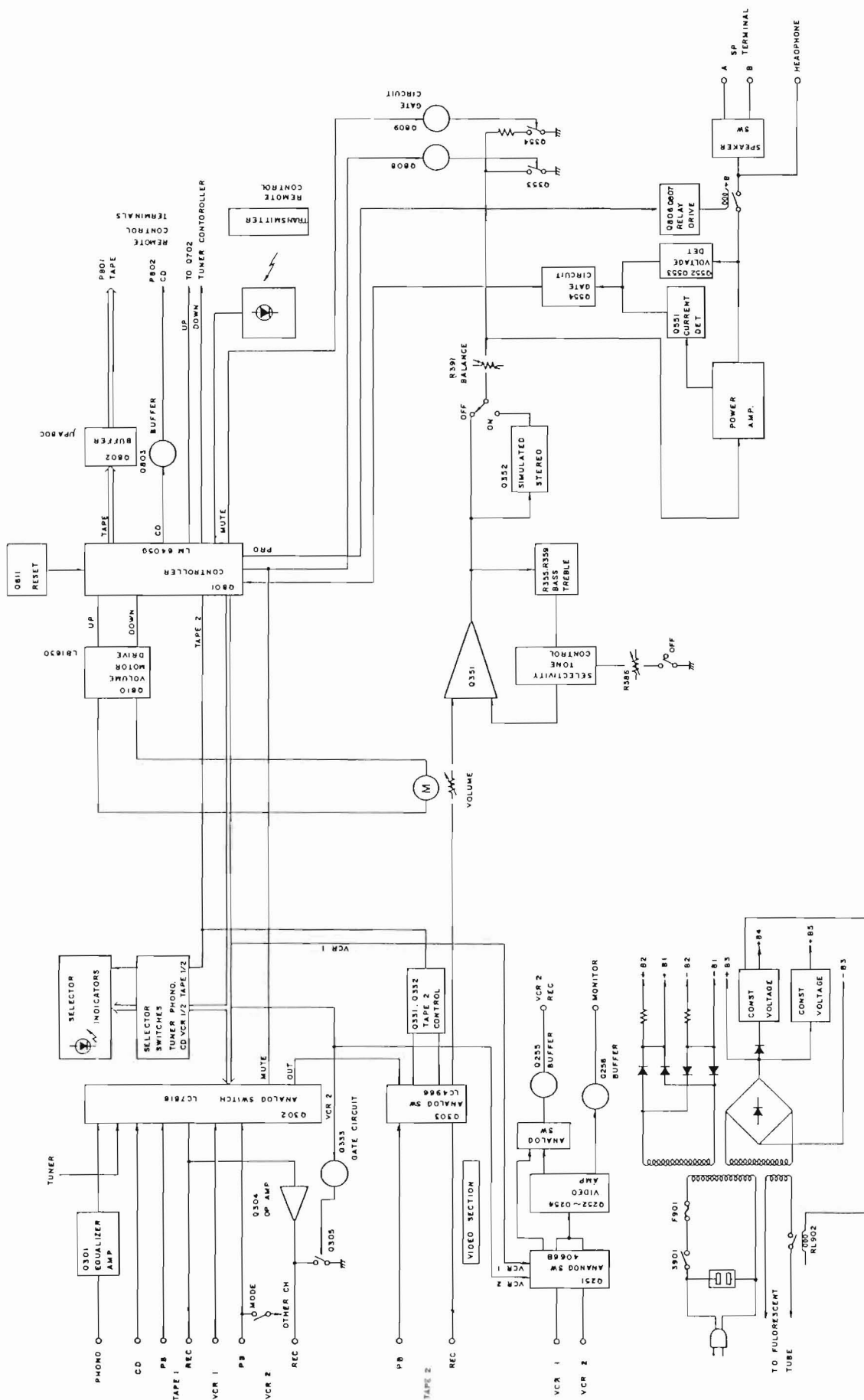

- TUNER SECTION -

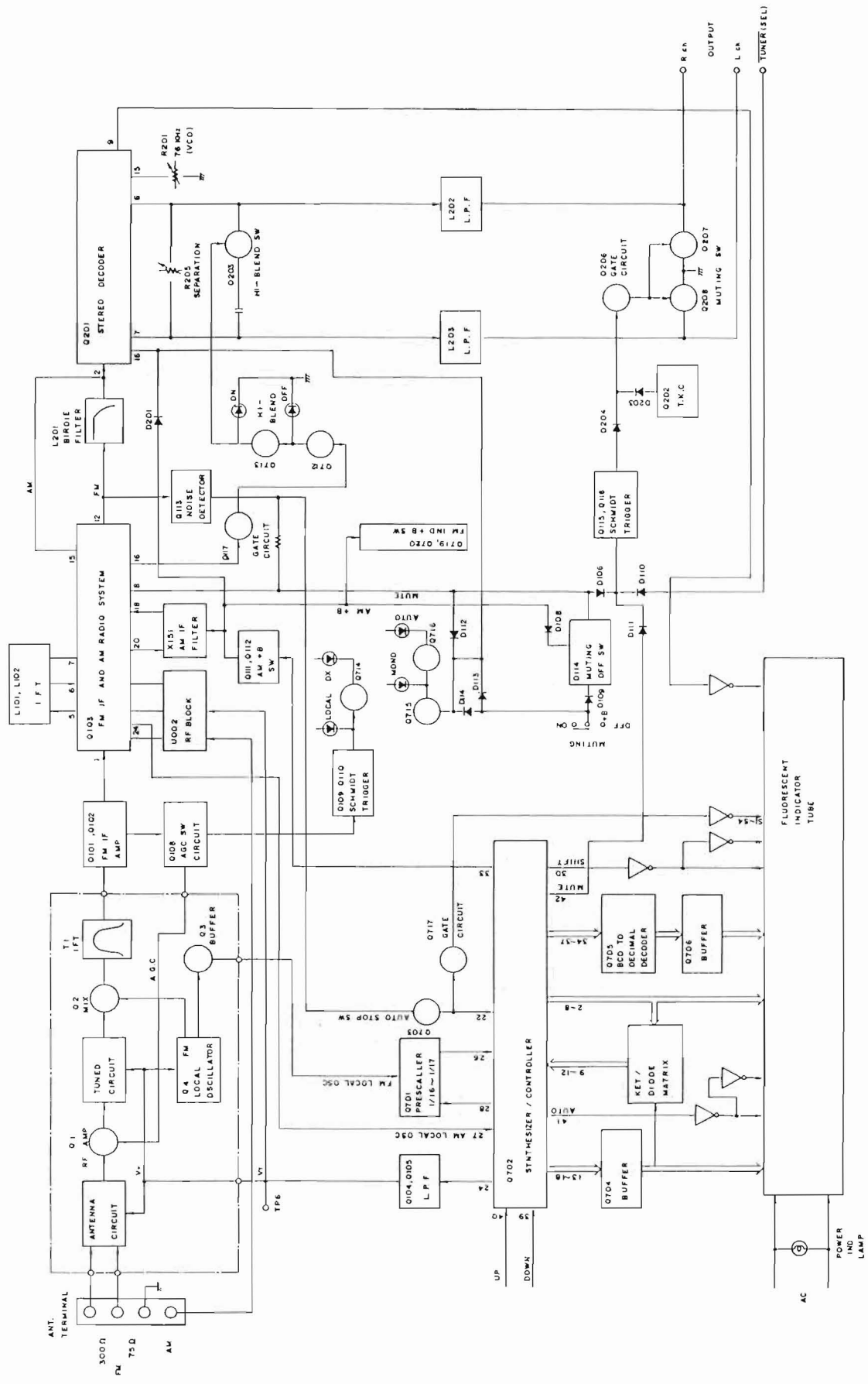

BLOCK DIAGRAM OF IC

LC7818 (Function Switch)

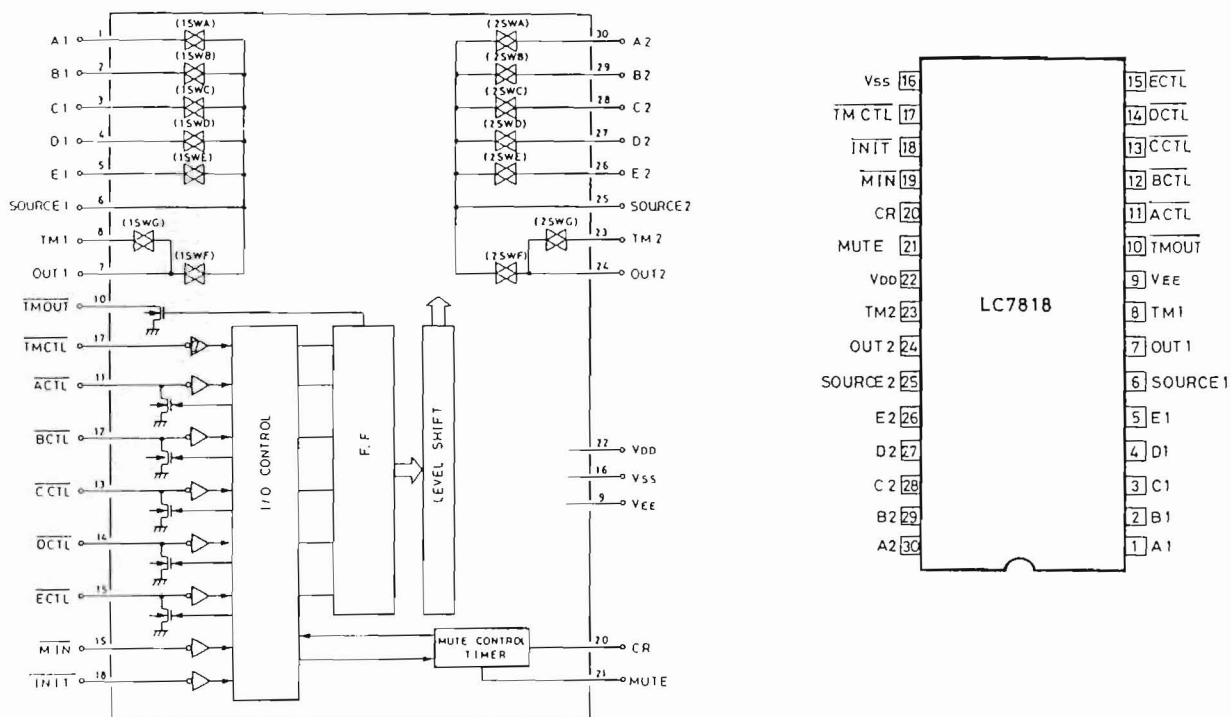

μPC1161C3 (Stereo decoder)

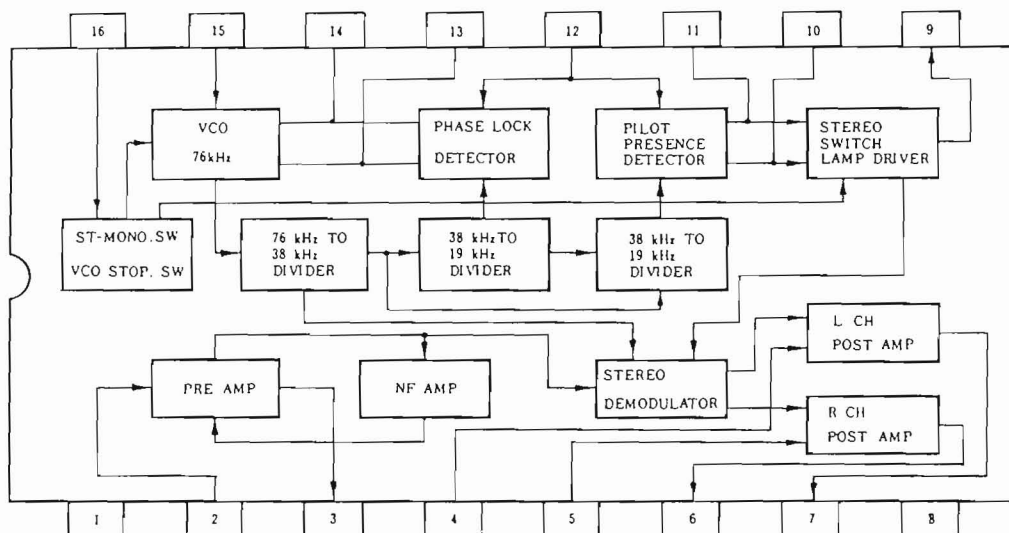

μPA80C (Buffer)

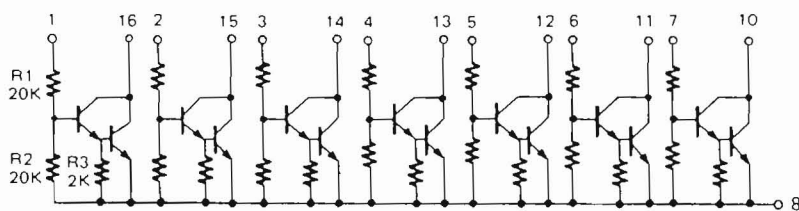

LB1630 (Motor Drive)

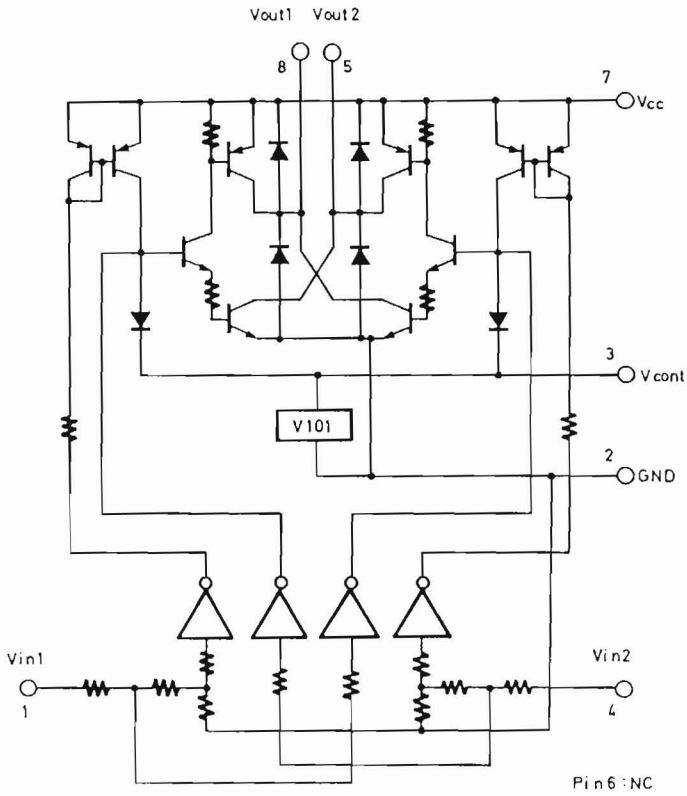

TRUTH TABLE

IN 1	IN 2	OUT 1	OUT 2	MOTOR
H	L	H	L	Normal
L	H	L	H	Reverse
H	H	OFF	OFF	Wait
L	L	OFF	OFF	Wait

LA1266 (FM IF and AM radio system)

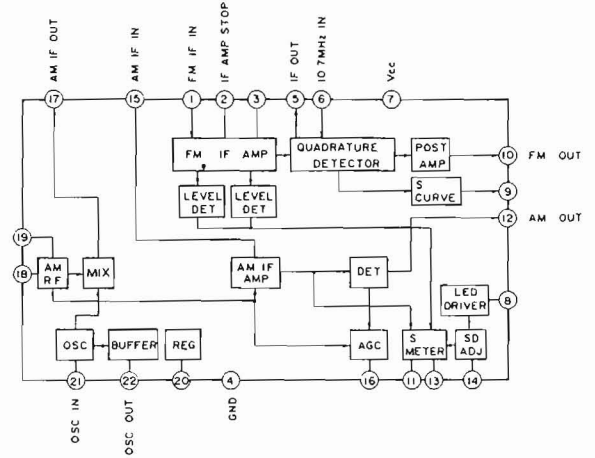

74LS145 (BCD to decimal decoder)

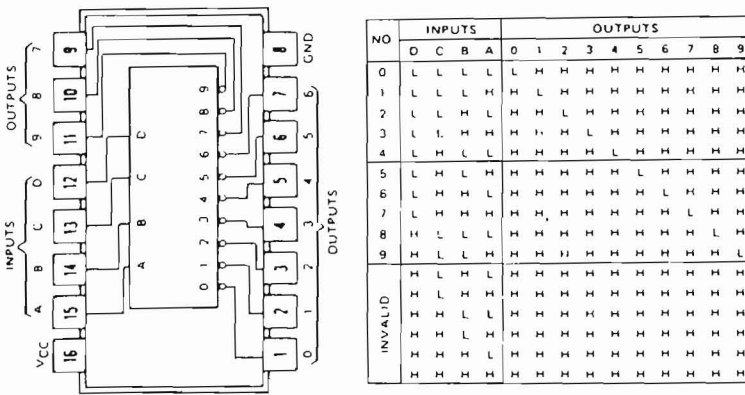

μPA81C (Buffer)

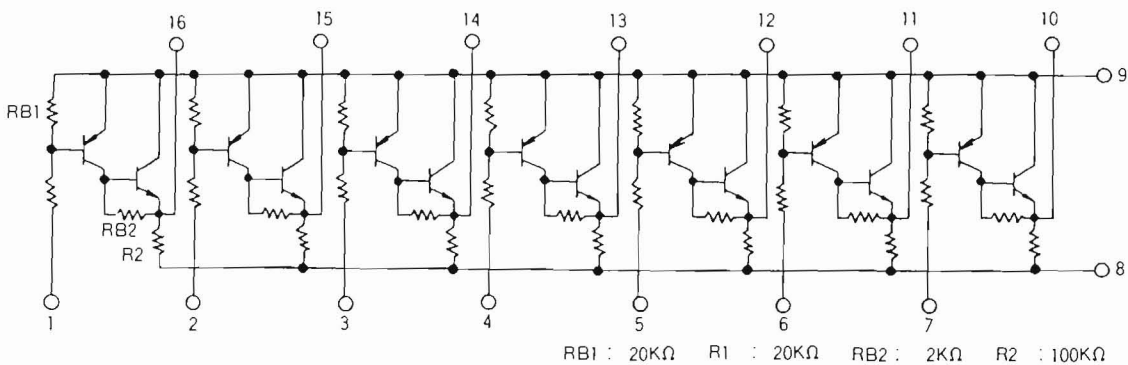

μ PB553AC (Prescaler)

Pin Connection

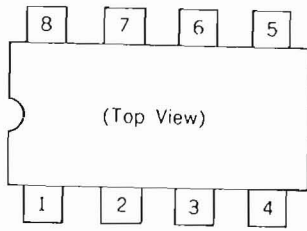

1. Pin 1 (Vcc) +5 volts Supply
2. Pin 2 (IN) FM local oscillator signal input
3. Pin 3 (CHK) Check terminal
4. Pin 4 (GND) Ground terminal
5. Pin 5 (OUT) Prescaler terminal
6. Pin 6 (PSC) Prescaler control terminal
7. Pin 7, 8 Not connected

Block Diagram

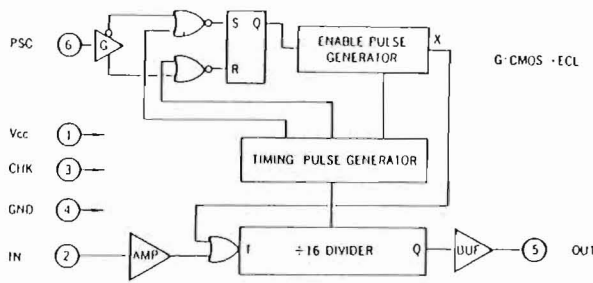

Timing Chart

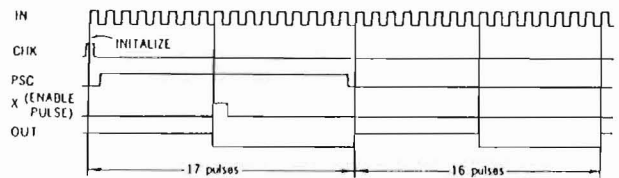

NJM4558/4559/4560 (Op. amplifier)

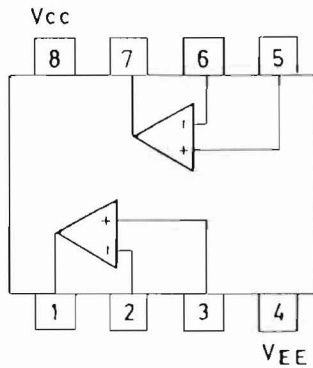

BA6124/LB1403 (Signal meter driver)

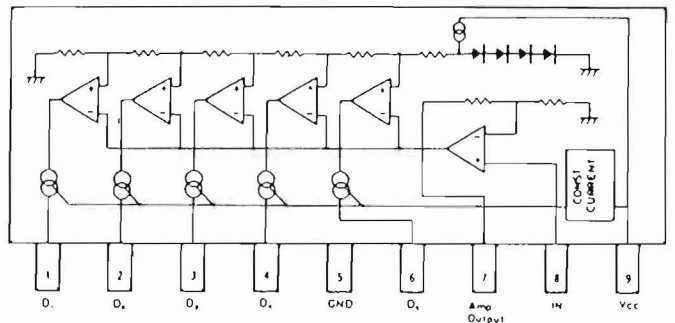

4066B/LC4966 (Analog switch)

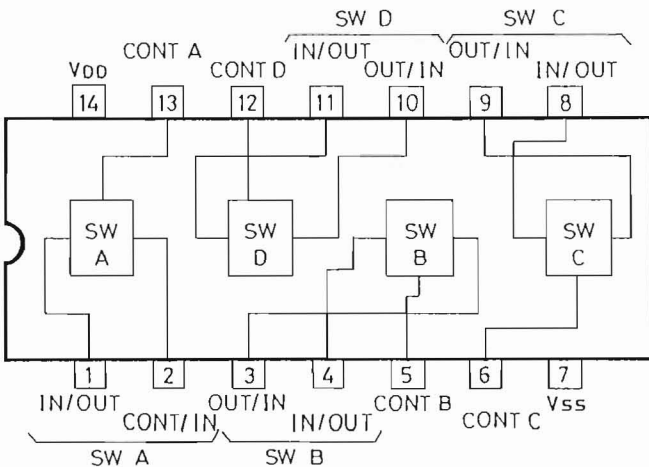

PACKING PROCEDURES

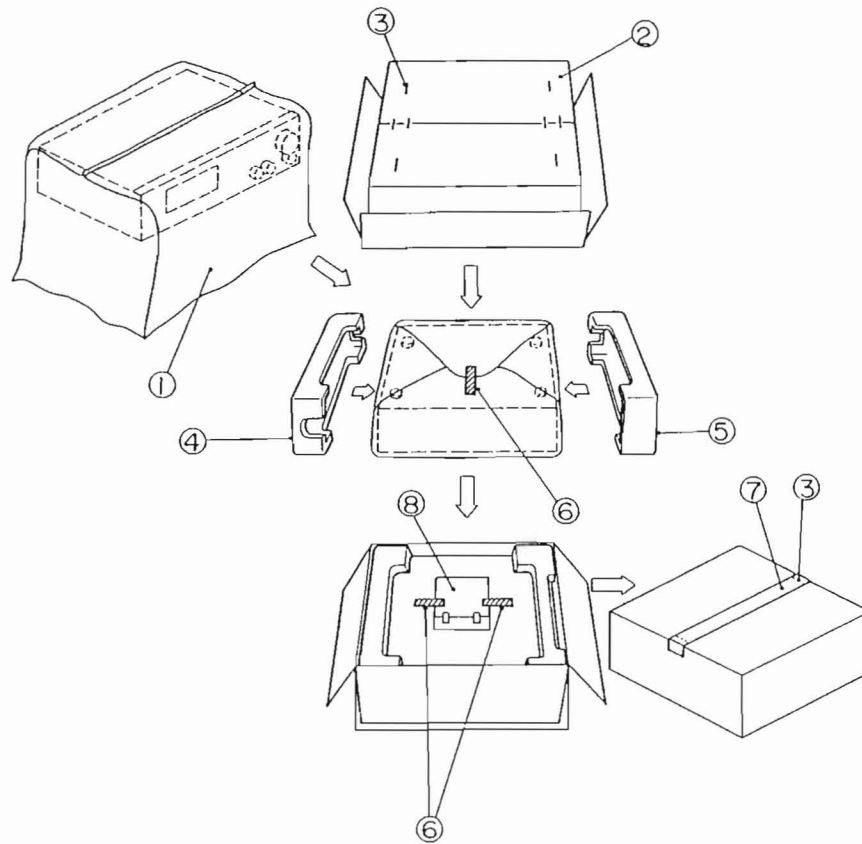

REF. NO.	PART NO.	DESCRIPTION
1	29100034	850X650mm, Poly-vinyl bag
2	29051456	Master carton box (Silver model)
	29051458	Master carton box (Black model)
3	282301	Sealing hook
4	29091158A	Pad R
5	29091157	Pad L
6	29110032	Tape
7	260012	Damplon tapc
8	Accessory bag ass'y	
	29341115	Instruction manual
	292092	FM antenna
	232119	NMA-3052, AM loop antenna
	2010141	Connection cord for cassette deck
	2010159	Connection cord for CD player
	3010054	UM-3, Two batteries
	24140003	RC-82S, Remote control transmitter
	29365020	Warranty card
	29100006A	250X350mm, Poly-vinyl bag

ADJUSTMENT PROCEDURES

Preparation

• Input

FM mono: 1kHz, 75kHz devi., 60dB/ μ V

FM stereo: 1kHz, L+R 67.5kHz devi.: Pilot signal 19kHz
7.5kHz devi.

AM: 400Hz, 30% mod.,

• Output

Connect the non-inductive type resistor of 8 ohms to the speaker terminal A of left and right channels unless otherwise noted.

• Standard knob position

TAPE MONITOR	SOURCE
VOLUME	Maximum
BASS/TREBLE/BALANCE	Center
MODE	STEREO
SPEAKER	A
SIMULATED STEREO	OFF
SELECTIVE TONE CONTROL	OFF

Amplifier section

1. Idling current adjustment

Connect the DC voltmeter to the terminals IID and VCT on the power amplifier pc board.

Adjust the semi-fixed resistors R507 and R607 so that the indication of voltmeter is 7.5 ± 1.5 mV.

Notes: VOLUME Maximum, Open load,
Adjust after switching on for 5 minutes.

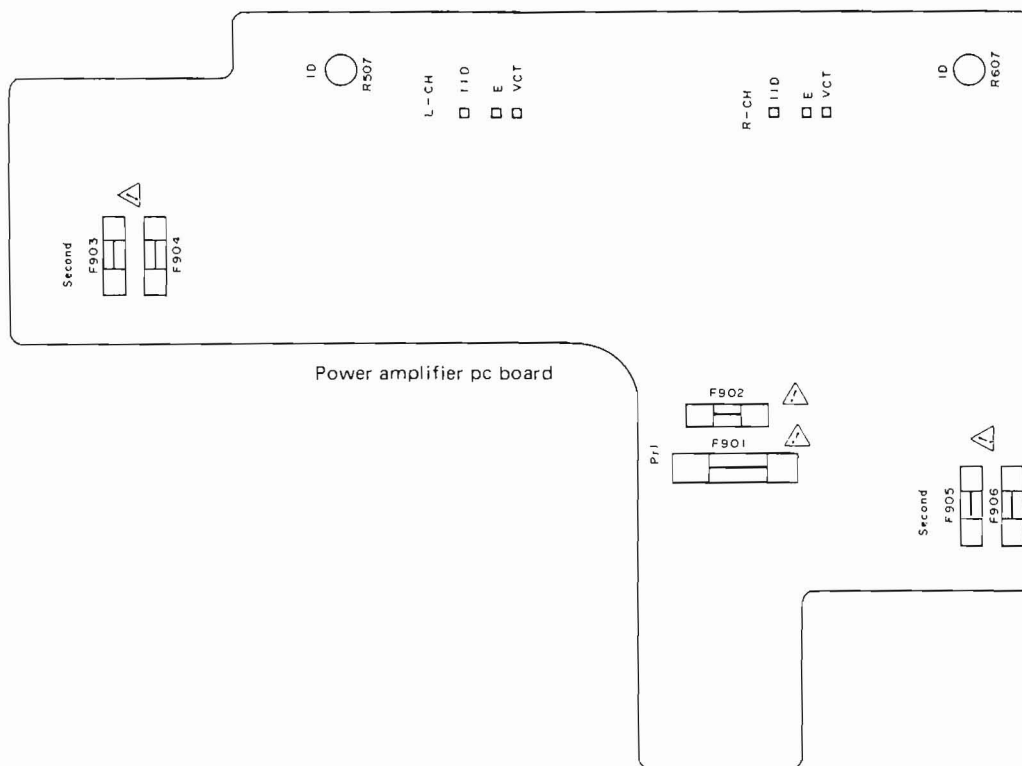

PRINTED CIRCUIT BOARD – PARTS LIST

POWER AMPLIFIER AND POWER SUPPLY PC BOARD (NAPS-2875-2A)

CIRCUIT NO.	PART NO.	DESCRIPTION
Transistors		
Q501, Q601	2211371 or 2211372	2SC2259(O-001) or 2SC2259(O-002)
Q502, Q602	2211732 or 2211733	2SC1845(F) or 2SC1845(E)
Q503, Q603	2211353 or 2211354	2SA949(O) or 2SA949(Y)
Q504, Q604	2211633 or 2211634	2SC2229(O) or 2SC2229(Y)
Q505, Q605	2211255	2SC1815(GR)
Q506, Q606	2212653 or 2212654	2SC3421(O) or 2SC3421(Y)
Q507, Q607	2211643 or 2211644	2SA965(O) or 2SA965(Y)
Q508, Q608 *	2201783, 2201784 or 2201786	2SC3854(O), 2SC3854(Y) or 2SC3854(P)
Q509, Q609 *	2201773, 2201774 or 2201776	2SA1490(O), 2SA1490(Y) or 2SA1490(P)

Q805	2211793	2SA992(E)
Q807, Q903	2211256	2SC1815(BL)
Q904	2211255, 2210746 or 2212485	2SC1815(GR), 2SC945A(P) or JC501(Q)
Q902, Q905	2201754, 2201755, 2201404 or 2201405	2SD1913(R), 2SD1913(S), 2SD1406(Y) or 2SD1406(GR)

Diodes		
D501, D502	223163	1SS133
D503, D603	4000068	VD1222
D802	223163	1SS133
D901-D904	223897 or 22380003	P300DL or 1N5402F
D905, D906	2239651 or 2243241	RD1.3EB1 or MTZ1.3A
D907	223862 or 223890	WL01 or W01RL
D908	223896 or 223880	1N4003F or GP101N4003
D909	223163	1SS133
D910	2239631 or 2243231	RD12EB1 or MTZ12A
D911	2239493 or 2243163	RD6.2EB3 or MTZ6.2C

Capacitors		
C501, C601	354780229	2.2μF, 50V, Elect.
C513, C613	354721019	100μF, 6.3V, Elect.
C515	354722219	220μF, 6.3V, Elect.
C516, C517	354790479	4.7μF, 100V, Elect.
C552	354722219	220μF, 6.3V, Elect.
C553	354780109	1μF, 50V, Elect.
C806	354744709	47μF, 16V, Elect.
C901	3500065A	0.01μF, AC400V/125V, IS
C904, C905	3504207	6800μF, 50V, Elect.
C906, C907	354761019	100μF, 35V, Elect.
C908, C909	391242217	220μF, 16V, Elect.

CAUTION: Replacement for transistor of mark *, if necessary, must be made from the same beta group (HFE) as the original type.

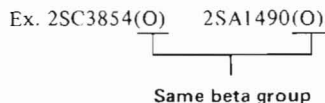

Q551-Q553	2211732 or 2211733	2SC1845(F) or 2SC1845(E)
Q651	2211733	2SC1845(E)
Q554, Q804	2211792 or	2SA992(F) or

PRINTED CIRCUIT BOARD VIEW FROM BOTTOM S

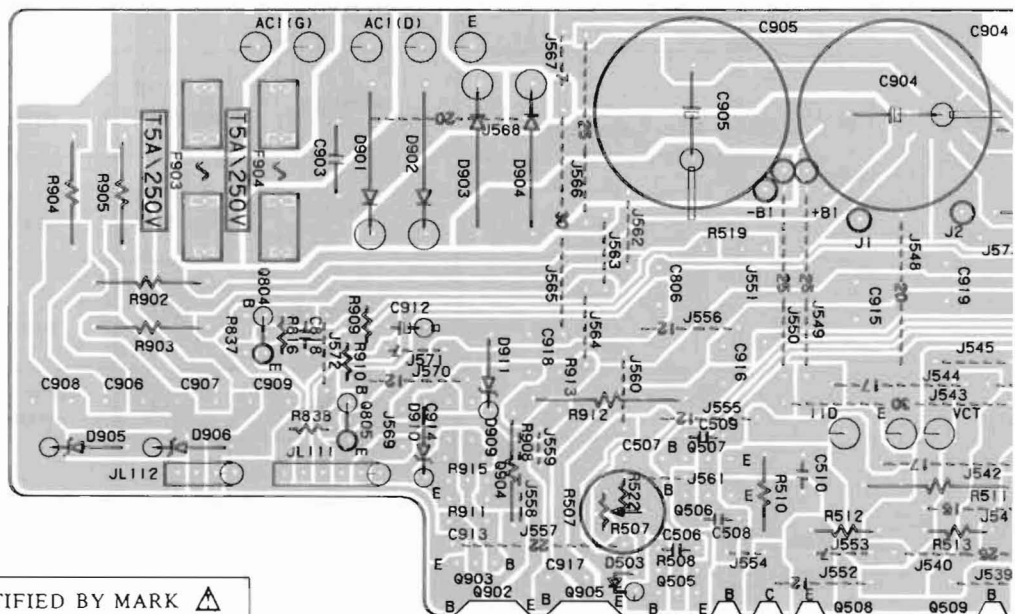

NOTE: THE COMPONENTS IDENTIFIED BY MARK  ARE CRITICAL FOR RISK OF FIRE AND ELECTRIC SHOCK. REPLACE ONLY WITH PART NUMBER SPECIFIED.

POWER AMPLIFIER AND POWER SUPPLY

C911	354752229	2200µF, 25V, Elect.
C912	354741019	100µF, 16V, Elect.
C914	354744709	47µF, 16V, Elect.
C915	354744719	470µF, 16V, Elect.
C916	354761019	100µF, 35V, Elect.
C918	354743319	330µF, 16V, Elect.
C919	354724719	470µF, 6.3V, Elect.
C920	354762209	22µF, 35V, Elect.
C921	354761019	100µF, 35V, Elect.

Resistors		
R507, R607	5210064	N06HR10KBD, Semi-fixed
R510, R610	442522714	270ohm, 1/2W, Metal oxide film
R511, R611	441620104	1ohm, 1W, Metal oxide film
R512, R612	4000063	0.47ohm, 2W, Metal plate
R513, R613	4000063	0.47ohm, 2W, Metal plate
R516, R616	442520824	8.2ohm, 1/2W, Metal oxide film
R521	442520104	1ohm, 1/2W, Metal oxide film
R902-R905	441623914	390ohm, 1W, Metal oxide film
R908	441620474	4.7ohm, 1W, Metal oxide film
R912	441721804	18ohm, 2W, Metal oxide film
R914	442522204	22ohm, 1/2W, Metal oxide film

Switch		
S901	25035398	NPS-111-L362P, Power

Relays		
RL801	25065134	NRL-2PSA-DC24-07
RL902	25065298	NRL-1P1A-DC12-40

Socket		
P116	25050270	NSCT-6P98

Plug		
P352	25055133	NPLG-3P117

Fuseholders		
F902a-F906a	25050065	YSH403T

Fuses		
F902	252074	2A-SE-EAK, Primary
F903, F904	252078	5A-SE-EAK, Secondary
F905, F906	252070	1A-SE-EAK, Secondary

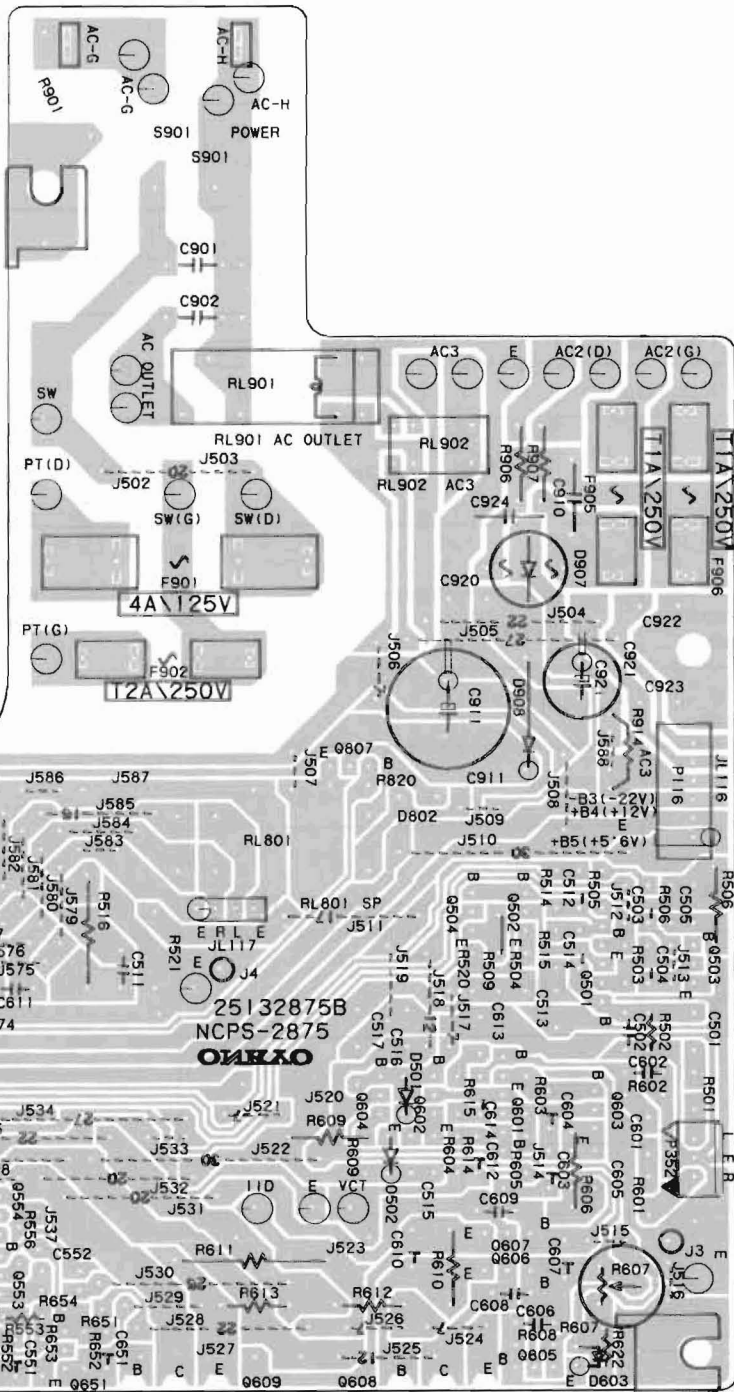

BOARD

PRINTED CIRCUIT BOARD VIEW FROM BOTTOM SIDE

PRINTED CIRCUIT BOARD - PARTS LIST

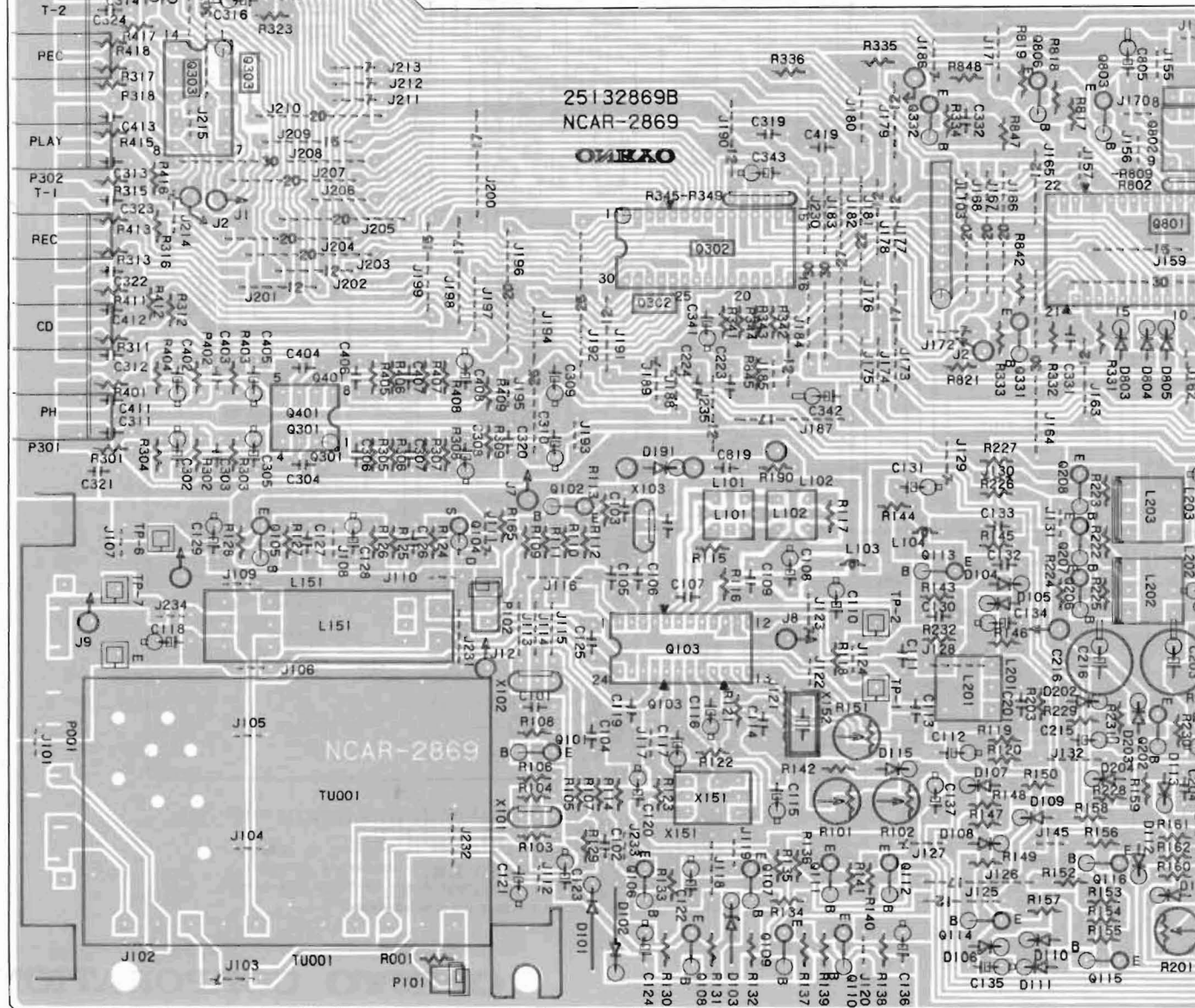
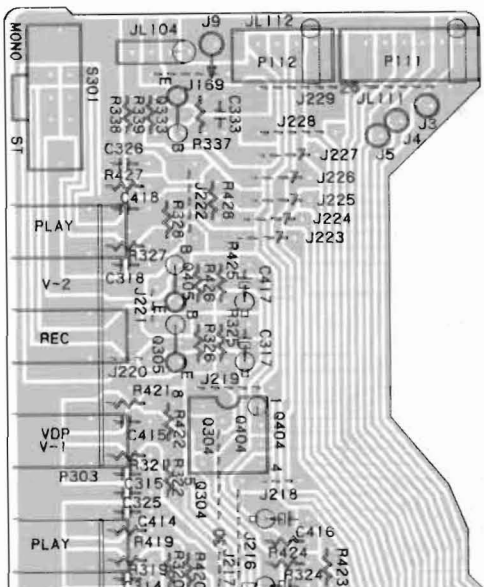

FM/AM TUNER PC BOARD(NAAR-2869-2A)

CIRCUIT NO. PART NO. DESCRIPTION

CIRCUIT NO.	PART NO.	DESCRIPTION
TU001	240072	Front end TFFG3E111X
ICs		
Q103	22240039	LA1266
Q201	222678	μPC1161C3
Q301, Q401	222534	NJM4559D-X
Q302	222996	LC7818
Q303	22240025	LC4966
Q304, Q404	222465 or 222502	NJM4558D or NJM4558DX
Q801	22240024	LM6405G-2077
Q802	222807	μPA81C
Transistors		
Q101, Q102	2211722 or 2211723	2SC1923(R) or 2SC1923(O)
Q104	2212294 or 2211293	2SK108(D) or 2SK68(M)
Q105, Q113	2211255	2SC1815(GR)

Q108-Q112	2211255,	2SC1815(GR),
Q114-Q117	2210746 or	2SC945A(P) or
Q202, Q332	2212485	JC501(Q)
Q203	2211945 or	2SK246(GR) or
	2212304	2SK381(D)
Q206, Q331	2211455,	2SA1015(GR),
Q333, Q806	2212495 or	JA101(Q) or
	2210803	2SA733(P)
Q207, Q208	2211705,	2SD655(E),
	2211706 or	2SD655(F) or
	2212794	2SD1468(R)
Q305, Q405	2212285 or	2SC2878(A) or
	2212286	2SC2878(B)
Q803, Q811	2211255,	2SC1815(GR),
	2210746 or	2SC945A(P) or
	2212485	JC501(Q)

Diodes

D101, D102	223132	1K60
D103	2241291	RD3.3FB1
D104-D114	223163	1SS133
D201-D204	223163	1SS133
D801	223163	1SS133
D803-D806	223163	1SS133

L101	233374	NFIF-4060
L102	233375	NFIF-4061

Coils

L103	233105	NCH-1005
L104	233031 or	NMC-9-1 or
	231081	NCH-2129
L201	233236	NMC-6027
L202, L203	233355A	NMC-4059

RF block

L151	232135	NMRF-7045
------	--------	-----------

Ceramic filters

X101-X103	3010043	SFE10.7MM
X151	3010075	SFL450B3
X152	3010076	BFU450C
X801	3010099	CSA4.00MG

Capacitors

C108	354741019	100 μ F, 16V, Elect.
C110	354780109	1 μ F, 50V, Elect.
C112	354782299	0.22 μ F, 50V, Elect.
C115	354780339	3.3 μ F, 50V, Elect.
C116	354741009	10 μ F, 16V, Elect.
C117	354780479	4.7 μ F, 50V, Elect.
C118, C120	354741009	10 μ F, 16V, Elect.
C121	354780339	3.3 μ F, 50V, Elect.
C123	354784799	0.47 μ F, 50V, Elect.
C124	354742209	22 μ F, 16V, Elect.
C128	354780479	4.7 μ F, 50V, Elect.
C129	354782299	0.22 μ F, 50V, Elect.
C131	354784799	0.47 μ F, 50V, Elect.
C134	354780229	2.2 μ F, 50V, Elect.
C135-C137	354741009	10 μ F, 16V, Elect.
C202	354742209	22 μ F, 16V, Elect.
C203	354744719	470 μ F, 16V, Elect.
C207, C208	354741009	10 μ F, 16V, Elect.
C210	354782299	0.22 μ F, 50V, Elect.
C211	354780339	3.3 μ F, 50V, Elect.
C212	354780109	1 μ F, 50V, Elect.
C213	370134714	470pF \pm 5%, 100V, APS
C215	354780479	4.7 μ F, 50V, Elect.
C216	354744719	470 μ F, 16V, Elect.
C220, C221	354780229	2.2 μ F, 50V, Elect.
C222, C803	354741009	10 μ F, 16V, Elect.
C807	354780339	3.3 μ F, 50V, Elect.
C815, C816	354780229	2.2 μ F, 50V, Elect.
C302, C402	354780229	2.2 μ F, 50V, Elect.
C305, C405	354721019	100 μ F, 6.3V, Elect.
C308, C408	354780229	2.2 μ F, 50V, Elect.
C309, C310	391242217	220 μ F, 16V, Elect.
C316, C317	354780229	2.2 μ F, 50V, Elect.
C341	354781099	0.1 μ F, 50V, Elect.
C342, C343	354780339	3.3 μ F, 50V, Elect.
C416, C417	354780229	2.2 μ F, 50V, Elect.

Resistors

R101	5210068	N06HR47KBD, Semi-fixed
R102	5210070	N06HR100KBD, Semi-fixed
R151	5210064	N06HR10KBD, Semi-fixed
R201	5210062	N06HR4.7KBD, Semi-fixed
R202	5210072	N06HR220KBD, Semi-fixed
R345-R349	49163103405	10kohmX5, 1/10W, Network
R802-R809	49163103408	10kohmX8, 1/10W, Network

Terminals

P001	25060087	NTM-2PDMN31, Antenna
P301-P303	25045166	NPJ-6PDBL60

Switch

S301	25065286	NPS-22112, Mode, VCR-2
------	----------	------------------------

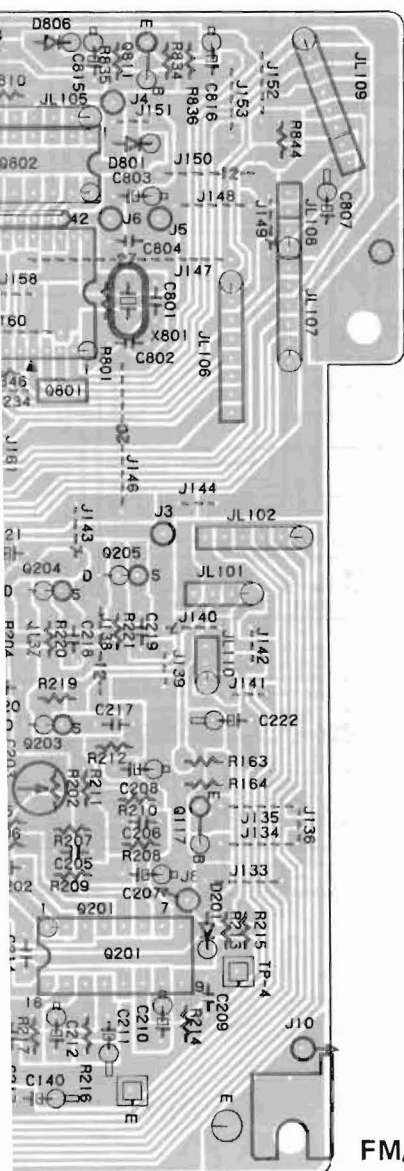

FM/AM TUNER PC BOARD

(Continued on page 29)

PRINTED CIRCUIT BOARD VIEW FROM BOTTOM SIDE

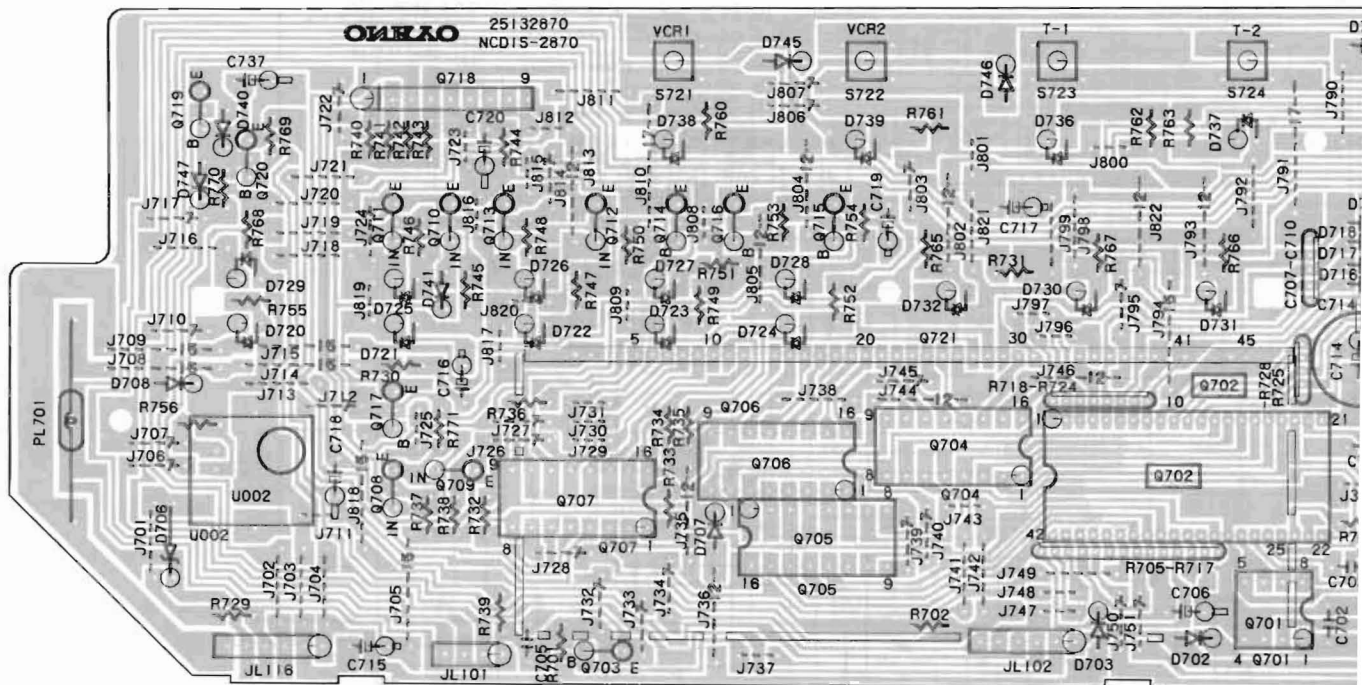

DISPLAY PC BOARD

CIRCUIT NO.	PART NO.	DESCRIPTION			
	Sockets				
P101, P102	2000657	NSAS-10P613	D740-D747	223163	1SS133
P111	25050270	NSCT-6P98		L.E.Ds	
P112	25050268	NSCT-4P96	D720	225141	SEL2213C
DISPLAY PC BOARD(NADIS-2870-2A)			D722-D724	225137CG,	SEL2413CG,
			D730	225137DG or	SEL2413DG or
			D733-D737	224137DY	SEL2413DY
			D726-D729	225142	SEL2913K
			D738, D739	225142	SEL2913K
	Opto. module			Capacitors	
U002	241068	BX-1407	C701	354723319	330μF, 6.3V, Elect.
	ICs		C704	354784799	0.47μF, 50V, Elect.
Q701	222619	μPB553AC	C706	353721019	100μF, 6.3V, Elect.
Q702	22240026	μPD1711CU-524	C714	3020027 or	0.047F, 5V or
Q704	222801	μPA80C		3000050	0.047F, 5.5V, Super
Q705	222741451	74LS145	C715	354782209	22μF, 50V, Elect.
Q706, Q707	222801	μPA80C	C716, C717	354780109	1μF, 50V, Elect.
	Transistors		C718, C719	354721019	100μF, 6.3V, Elect.
Q703, Q717	2211255,	2SC1815(GR),	C720	354741009	10μF, 16V, Elect.
Q720	2210746 or	2SC945A(P) or	C721-C729	3020031	CN3RAE331M, Block
	2212485	JC501(Q)	C730-C735	3020030	CN3R7E331M, Block
Q712, Q713	2212600	DTA124FS	C736, C737	354741019	100μF, 16V, Elect.
Q714-Q716	2211256	2SC1815(BL)		X'tal	
Q719	2211705,	2SD655(E),	X701	3010091	XTL-4.5M
	2211706 or	2SD655(F) or		Resistors	
	2212794	2SD1468(R)	R705-R717	49163223413	22kohmX13, 1/10W, Network
	Fluorescent tube		R718-R724	49163104407	100kohmX7, 1/10W, Network
Q721	212037	8-BT-49GK	R725-R728	49163104404	100kohmX4, 1/10W, Network
	Lamp			Switches	
PL701	210064A	6.3V, 0.25 A	S701-S715	25035548	NPS-111-SS10
	Diodes		S718-S724	25035548	NPS-111-SS10
D701-D705	223163	1SS133			
D706	2239472 or	RD5.6EB2 or			
	2243152	MTZ5.6B			
D707-D719	223163	1SS133			

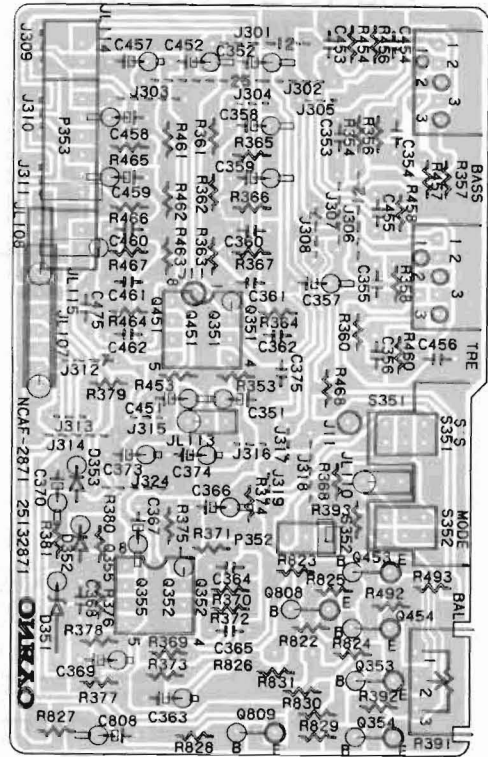
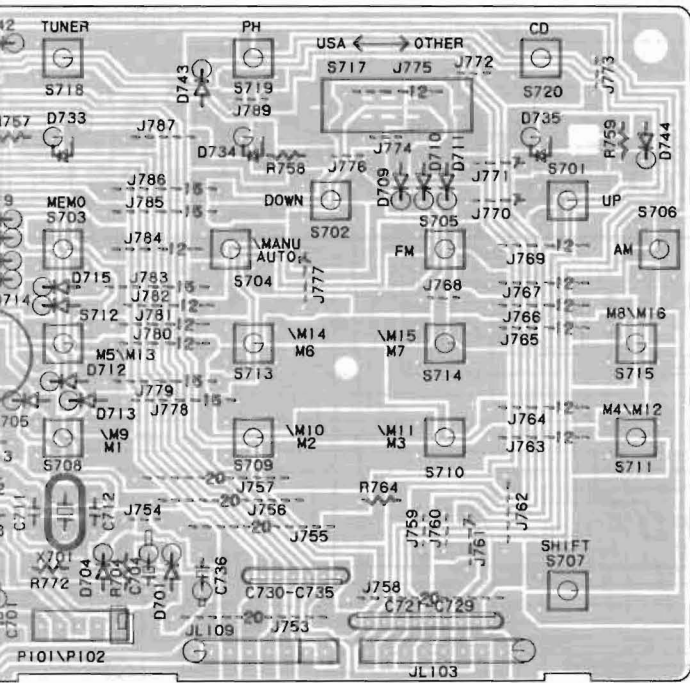

PREAMPLIFIER PC BOARD

Holders	
27190518	APR
27190519	Selector
Cushion	
28140538	10X40X3.5

PREAMPLIFIER PC BOARD(NAAF-2871-2A)

CIRCUIT NO. PART NO. DESCRIPTION

ICs	
Q351, Q451	222579 or 222570 NJM4560D or NJM4560DX
Q352, Q355	222465 or 222502 NJM4558D or NJM4558DX

Transistors	
Q353, Q354	2212285 or 2212286 2SC2878(A) or 2SC2878(B)
Q808, Q809	2211455, 2210803 or 2212495 2SA1015(GR), 2SA733(P) or JA101(Q)

Capacitors	
C351, C451	354780229 2.2μF, 50V, Elect.
C352, C452	354741009 10μF, 16V, Elect.
C354, C454	352983396 0.33μF, 50V, Non-polar elect.
C357, C457	354741009 10μF, 16V, Elect.
C358, C458	354781099 0.1μF, 50V, Elect.
C359, C459	354781099 0.1μF, 50V, Elect.
C363	354741009 10μF, 16V, Elect.
C366	354780229 2.2μF, 50V, Elect.
C373, C374	354780339 3.3μF, 50V, Elect.
C808	354741009 10μF, 16V, Elect.

Resistors	
R355, R455	5104202 N12RGLC50KC25Z, Variable, Bass
R359, R459	5104202 N12RGLC50KC25Z, Variable, Treble
R391	5104201 N12RLC250KW25Z, Variable, Balance

Switches	
S351, S352	25035556 NPS-222-L518

Sockets	
P352	2000590 NSAS-6P546
P353	25050270 NSCT-6P98

PRINTED CIRCUIT BOARD VIEW FROM BOTTOM SIDE

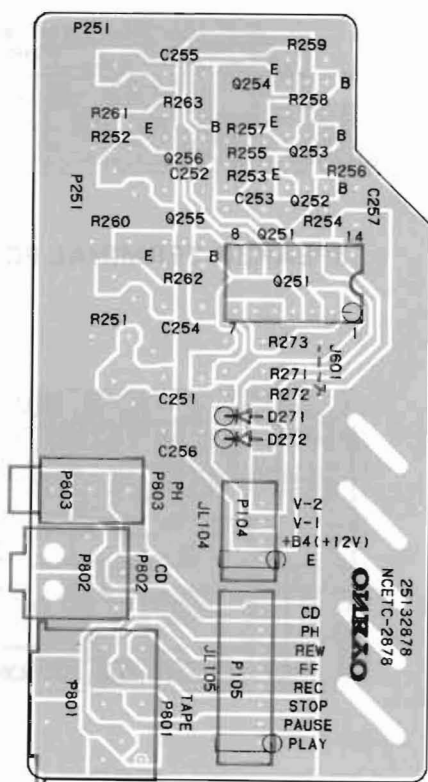

REMOTE CONTROL TERMINAL PC BOARD

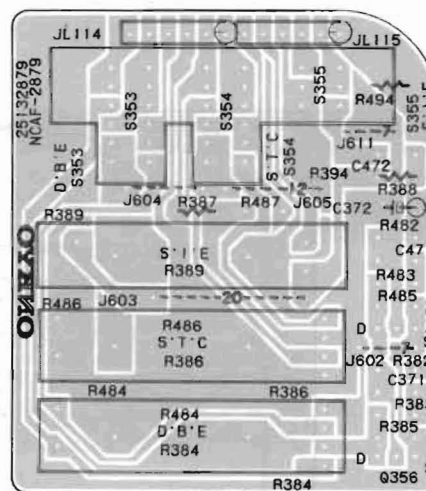

SWITCH PC BOARD

PRINTED CIRCUIT BOARD – PARTS LIST

REMOTE CONTROL TERMINAL PC BOARD (NAETC-2878-2)

CIRCUIT NO.	PART NO.	DESCRIPTION
		IC
Q251	222840661	4066B
		Transistors
Q252	2211455, 2210803 or 2212495	2SA1015(GR), 2SA733(P) or JA101(Q)
Q253-Q256	2211255, 2210746 or 2212485	2SC1815(GR), 2SC945A(P) or JC501(Q)
		Diodes
D271, D272	223163	1SS133
		Capacitors
C251-C253	354741009	10 μ F, 16V, Elect.
C254, C255	354724719	470 μ F, 6.3V, Elect.
C256	354741009	10 μ F, 16V, Elect.
		Terminal
P251	25045216	NPJ-4PDBL94
		Sockets
P801	25050294	NSCT-8P121
P104	25050268	NSCT-4P96
P105	25050272	NSCT-8P100
		Jack
P802	25045215	S-G8515

SWITCH PC BOARD(NAAF-2879-2)

CIRCUIT NO.	PART NO.	DESCRIPTION
R386, R486	6182003	N25LGL100KRD10Z, Variable resistor
S354	25035557	NPS-142-L519, Push switch

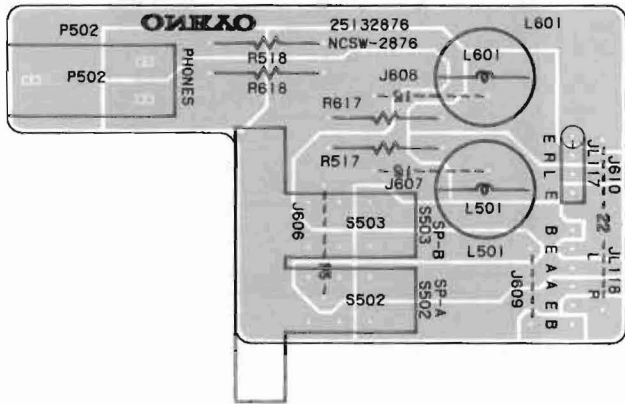

SPEAKER SWITCH PC BOARD

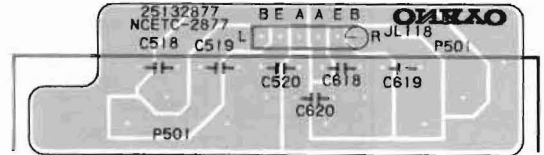

SPEAKER TERMINAL PC BOARD

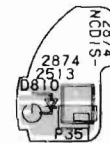
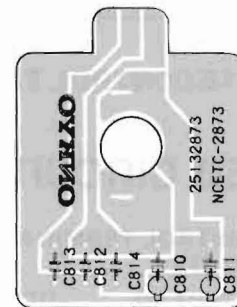
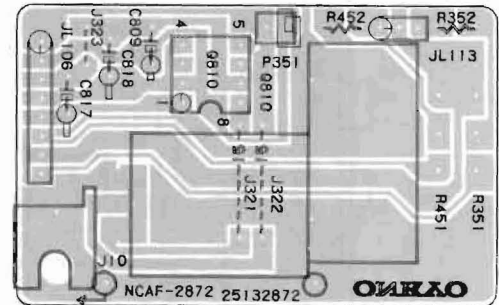

VOLUME PC BOARD

VOLUME PC BOARD(NAAF-2872-1)

CIRCUIT NO.	PART NO.	DESCRIPTION
Q810	222963	LB1630, IC
C809, C817	354780339	3.3 μ F, 50V, Elect. capacitors
C818	354780339	3.3 μ F, 50V, Elect. capacitor
R351, R451	5104200	N16RGM50KA30F, Variable resistor, Volume
P351	2000635	NSAS-4P591, Socket

VOLUME INDICATOR PC BOARD(NADIS-2874-1)

CIRCUIT NO.	PART NO.	DESCRIPTION
D810	225219	SLC-22UR4F, L.E.D
	27270103A	Spacer

SPEAKER SWITCH PC BOARD(NASW-2876-1A)

CIRCUIT NO.	PART NO.	DESCRIPTION
L501, L601	231001	S-1.3B, Coils
R517, R617	442520474	4.7ohm, 1/2W, Metal oxide film resistors
R518, R618	441623914	390ohm, 1W, Metal oxide film resistors
S502, S503	25035517	NPS-222-L479, Push switch
P502	25045139	HLJ-0540-01-010, Stereo headphone terminal

SPEAKER TERMINAL PC BOARD(NASW-2877-1A)

CIRCUIT NO.	PART NO.	DESCRIPTION
P501	25060093	NTM-8PDML34, Speaker terminal

DISASSEMBLING PROCEDURES

1. Top cover

Remove a screw holding the top cover and the back panel.

Remove the four screws holding the back panel and the chassis.

2. Front panel

Remove the top cover.

Remove the six screws holding the front panel and the front bracket.

3. Bottom board (Chassis)

Remove the top cover and the front panel.

Remove the five screws A holding the back panel and the chassis. (See Fig. 1)

Remove the four screws B and the two screws C. (See Fig. 2)

Remove the two screws D holding the chassis and the front bracket. (See Fig. 2)

Remove the three screws E on the AM/FM tuner pc board. (See Fig. 3)

4. Front bracket

Remove the bottom board (Chassis).

Remove the bracket between the front bracket and the radiator.

Remove the two screws F. (See Fig. 2)

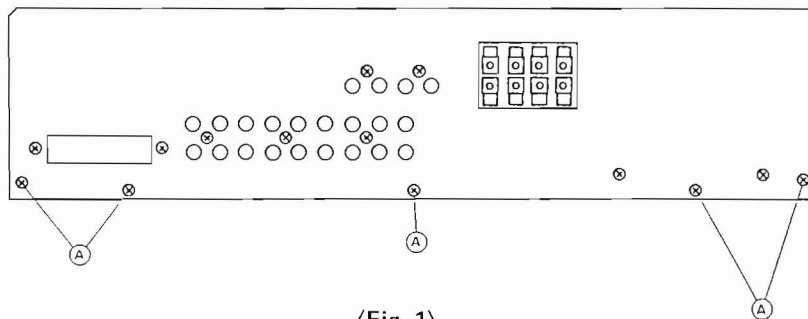

<Fig. 1>

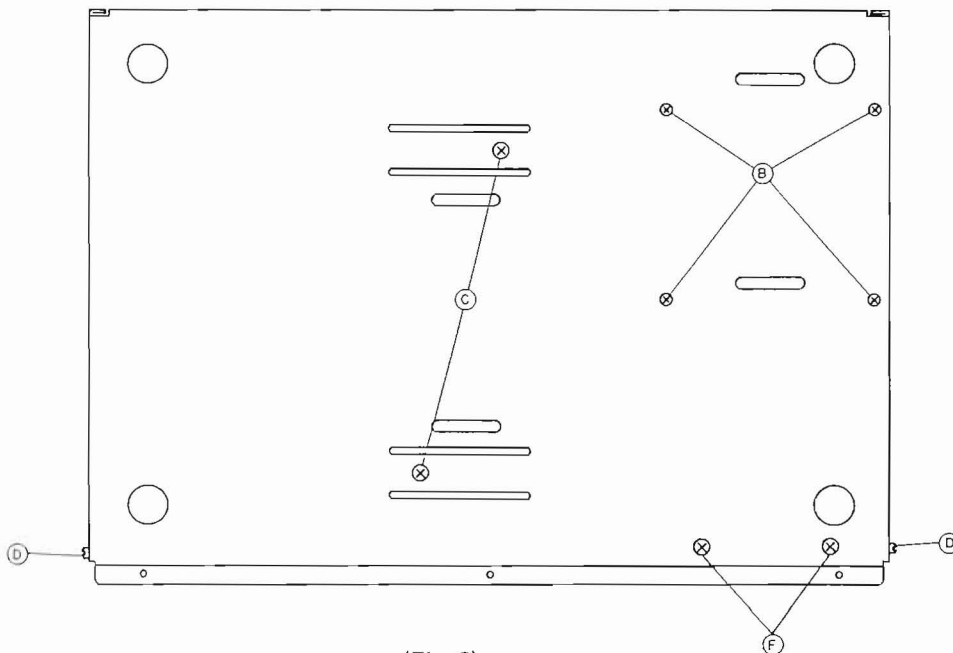

<Fig. 2>

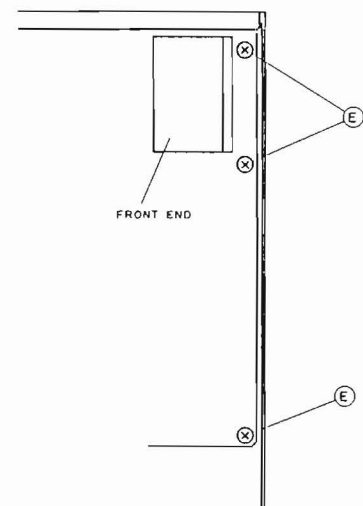

<Fig. 3>

ONKYO CORPORATION

International Division: No. 24 Mori Bldg., 23-5, Nishi-Shimbashi 3-chome, Minato-ku,
TOKYO 105, JAPAN Tel: 03-432-6987 Fax: 03-436-6979 TLX: 242-3551 ONKYO J

ONKYO DEUTSCHLAND GmbH ELECTRONICS
Industriestrasse 18, 8034 Germering, WEST GERMANY
Telex: 41-521726 ONKY. Tel. 089-84-9320

FM section

Item	Step	Connection of instrument	FM SG output	Stereo modulator output	Turning dial setting	Output indicator	Adjustment	Adjustment
FM IF	1	Fig. 1	99.1MHz 1kHz, 75kHz devi. 65dBf (60dB)	-	99.1MHz	DC voltmeter	L101	0V
	2	Fig. 1		-	99.1MHz	Distortion analyzer	L102	Minimum
Stereo level	1	Fig. 3	99.1MHz 17.2dBf (12dB) Ext. modulation	L + R: 1kHz 67.5kHz devi. Pilot signal: 19kHz 7.5kHz devi.	99.1MHz	Stereo indicator	R101	Light on
	2		99.1MHz 16.2dBf (11dB) Ext. modulation					Light off
VCO		Fig. 2	99.1MHz 1kHz, 75kHz devi. 65dBf (60dB)	-	99.1MHz	Frequency counter	R201	19kHz ±
Stereo Distortion		Fig. 3	99.1MHz 65dBf (60dB) Ext. modulation	L or Rch. 1kHz	99.1MHz	Distortion analyzer	IF on front end	Minimum
Stereo Separation	1	Fig. 3	99.1MHz 65dBf (60dB) Ext. modulation	Lch. 1kHz	99.1MHz	Rch. AC voltmeter	R202	Minimum
	2			Rch. 1kHz				Lch. AC voltmeter
Hi-blend level		Fig. 3	99.1MHz 35.2dBf (30dB) 1kHz, 75kHz devi.	-	99.1MHz	Hi-blend indicator	R102	Light off

AM section

Step	AM SG output	Tuned frequency	Output indicator	Adjustment point	Adjust for	Remarks
1		522kHz	Digital DC voltmeter	OSC on RF block	1.4V ± 0.1V	
2		1611kHz	Digital DC voltmeter		8.0 ± 1.0V	
3	603kHz 400Hz 30% mod. 60dB/m	603kHz	AC voltmeter	RF on RF block	Maximum	Repeat the steps 3 and 4 until no further adjustment is necessary.
4	1404kHz 400Hz 30% mod. 60dB/m	1404kHz	AC voltmeter	TC on RF block	Maximum	
5	999kHz 400Hz 30% mod. 60dB/m	999kHz	AC voltmeter	X151	Maximum	
6	Same as above	999kHz	First signal indicator	R151	Light on	

Reference specification
Tuned voltage 8
10
Auto stop level

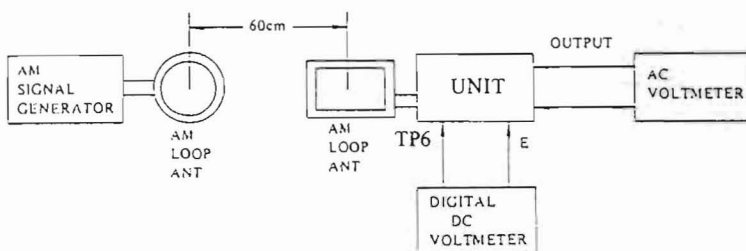

or	Remarks
	Muting switch: off Repeat the steps 1 and 2 until no further adjustment is necessary
	Muting switch: on
	Maximum and same separation

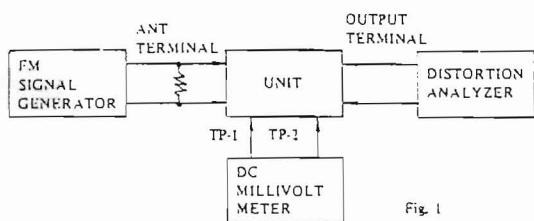

Fig. 1

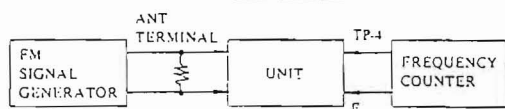

Fig. 2

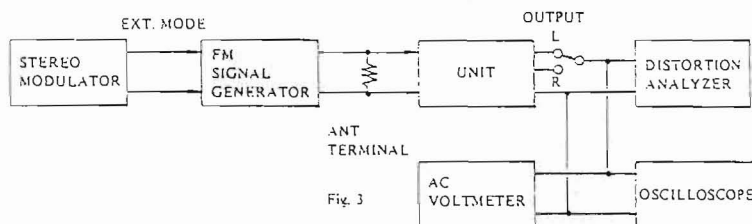
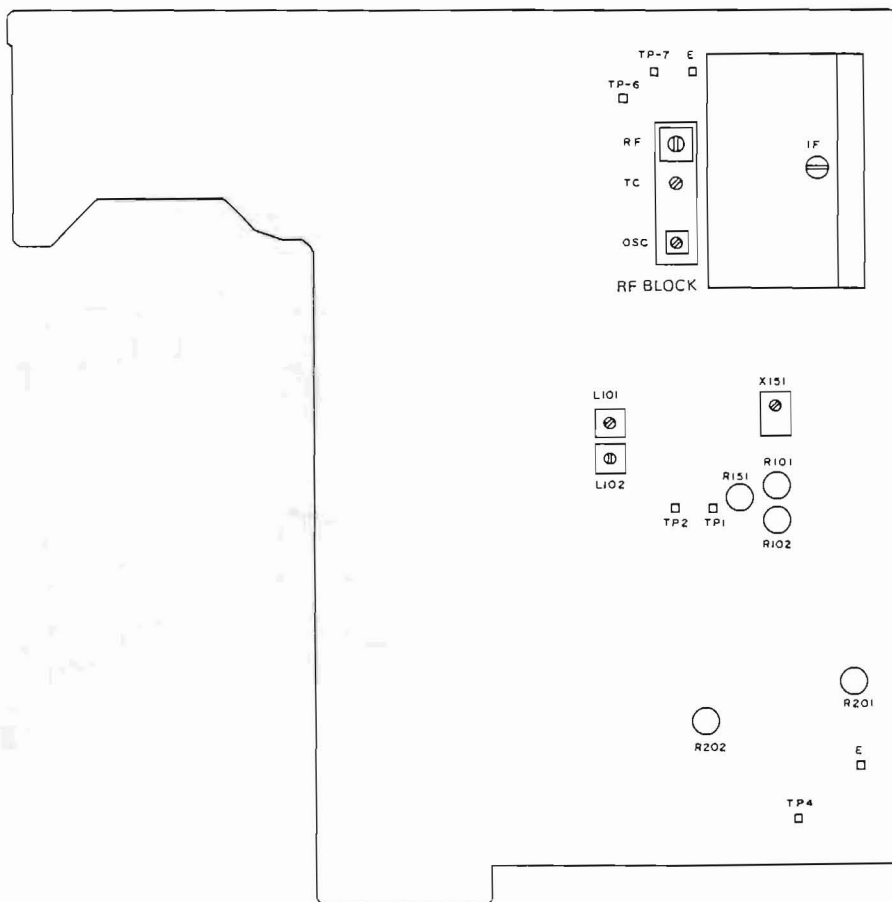

Fig. 3

ations
5MHz $2.0 \pm 0.5V$
0MHz $7.7 \pm 0.5V$
1: Less than 66dB/m
1: Less than 20dB μ



SCHEMATIC DIAGRAM - AMPLIFIER SECTION -

1

2

3

4

5

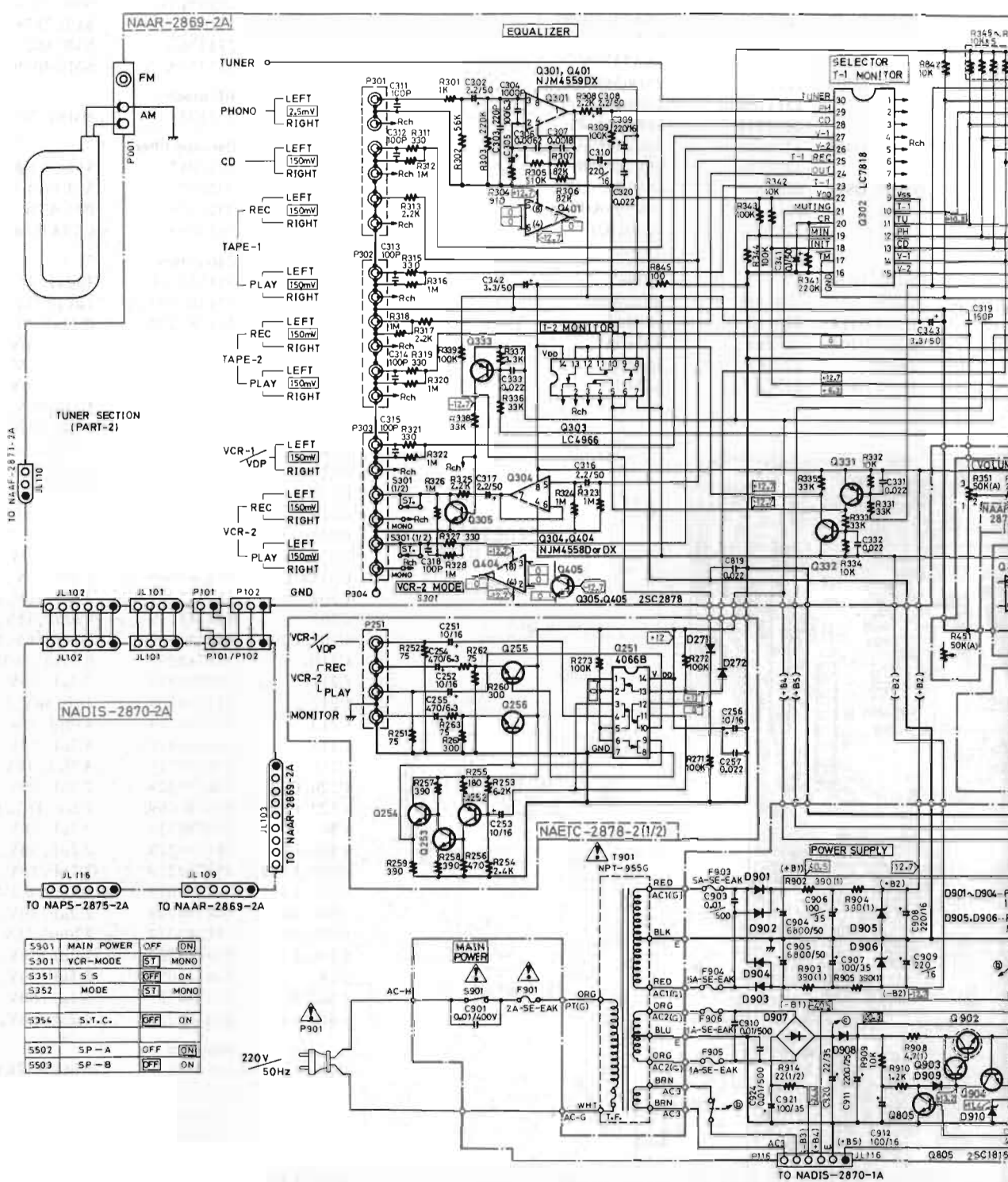

5901	MAIN POWER	OFF	ON
5301	VCR-MODE	ST	MONO
5351	S S	OFF	ON
5352	MODE	ST	MONO
5354	S.T.C.	OFF	ON
5502	SP-A	OFF	ON
5503	SP-B	OFF	ON

- 87 85 1630211088 30 29 ---1716 42 41 ---2322
- 1234 1334567 1 2 ---1415 1 2 ---2021
- NJM4558 4066B LC4966 LC7818 LM64050-2077
- 25C1815 25C945 25A1015 25C1845 25A733 25C2878
- JCS01 JA101 25A932 25C2634

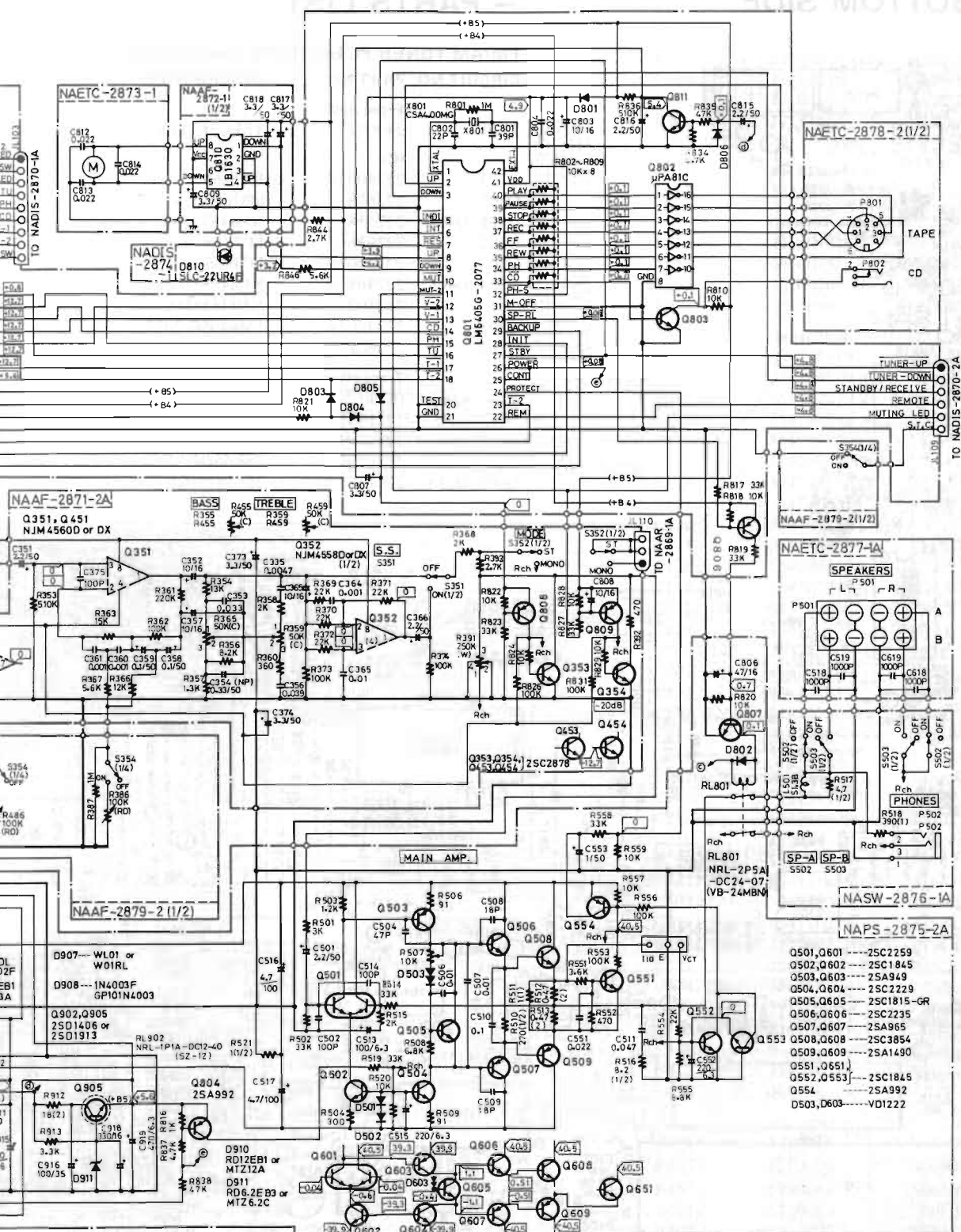

NOTES

- ALL RESISTORS ARE IN OHMS 1/4 WATTS UNLESS OTHERWISE NOTED.
- ALL CAPACITORS ARE IN PF/B0WV UNLESS OTHERWISE NOTED.
- ELECTROLYTIC CAPACITORS (EAP) ARE IN μ F/WV.
- ALL DIODES ARE 1S133 UNLESS OTHERWISE NOTED.
- ALL PNP TRANSISTORS ARE 2SA1015-GR OR 2SA733-P OR JA101-Q UNLESS OTHERWISE NOTED.
- ALL NPN TRANSISTORS ARE 2SC1815-GR OR 2SC945A-P OR JCG01-Q OR 2SC2634-R UNLESS OTHERWISE NOTED.
- THE COMPONENTS IDENTIFIED BY MARK A ARE CRITICAL FOR SAFETY. REPLACE ONLY WITH PART NUMBER SPECIFIED.
- VOLTAGE (MEASURED WITH V.T.V.M) \square IS DC VOLTAGE (NO INPUT SIGNAL, TUNER POSITION)

ONKYO CORPORATION

A

B

C

D

SCHEMATIC DIAGRAM

- TUNER SECTION -

1

2

3

4

5

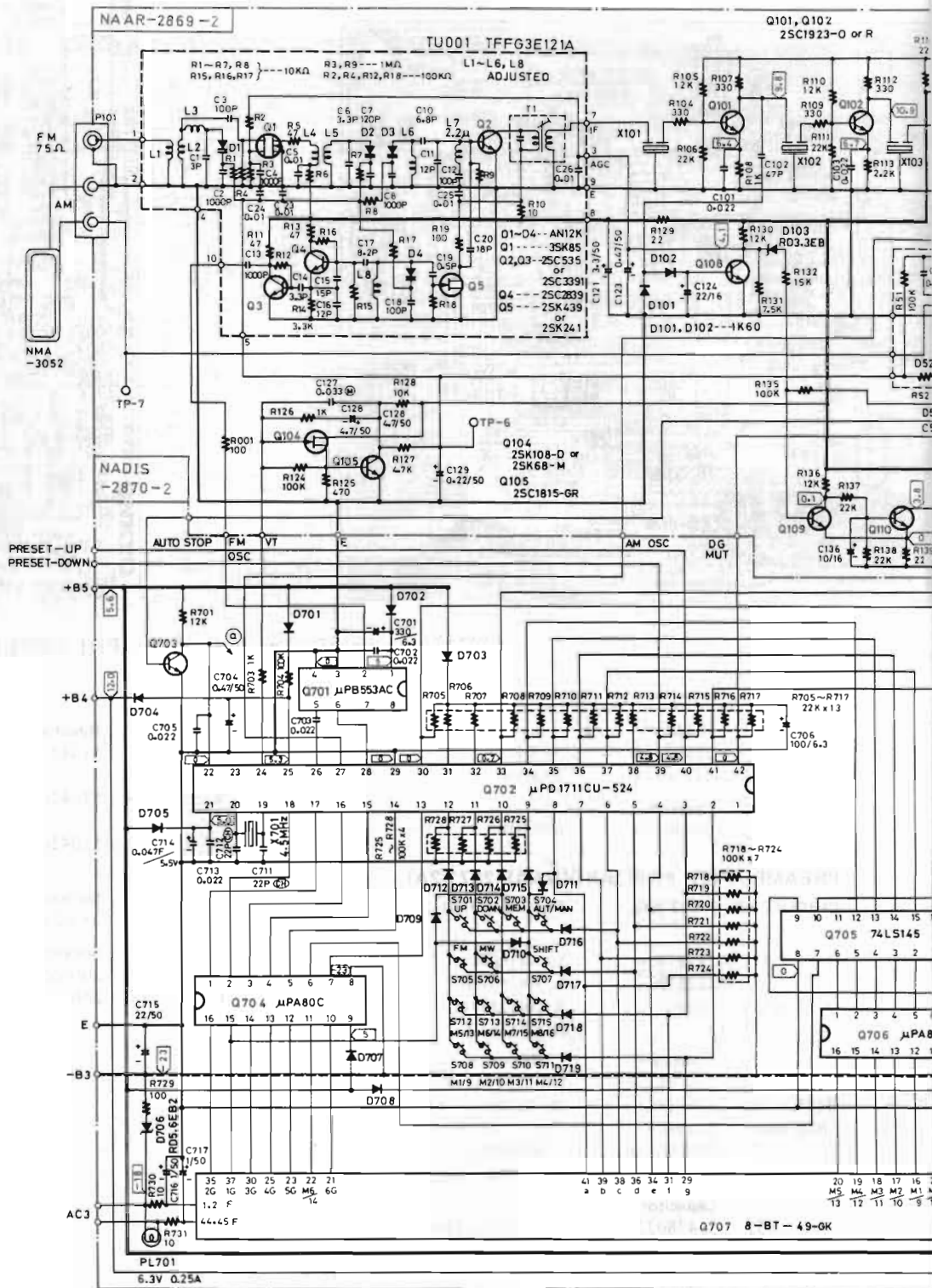

25K108
25K381
25K246



25C1815
25A1015
25C945
JC501
25C1923

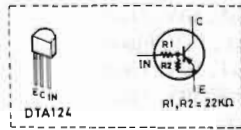

DTA124



µPB553AC



LA1266

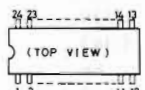

µPC174LS145
µPA8

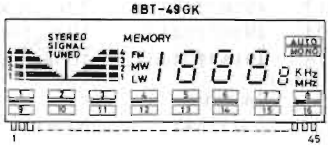
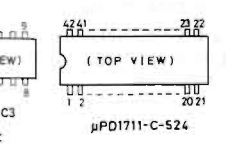
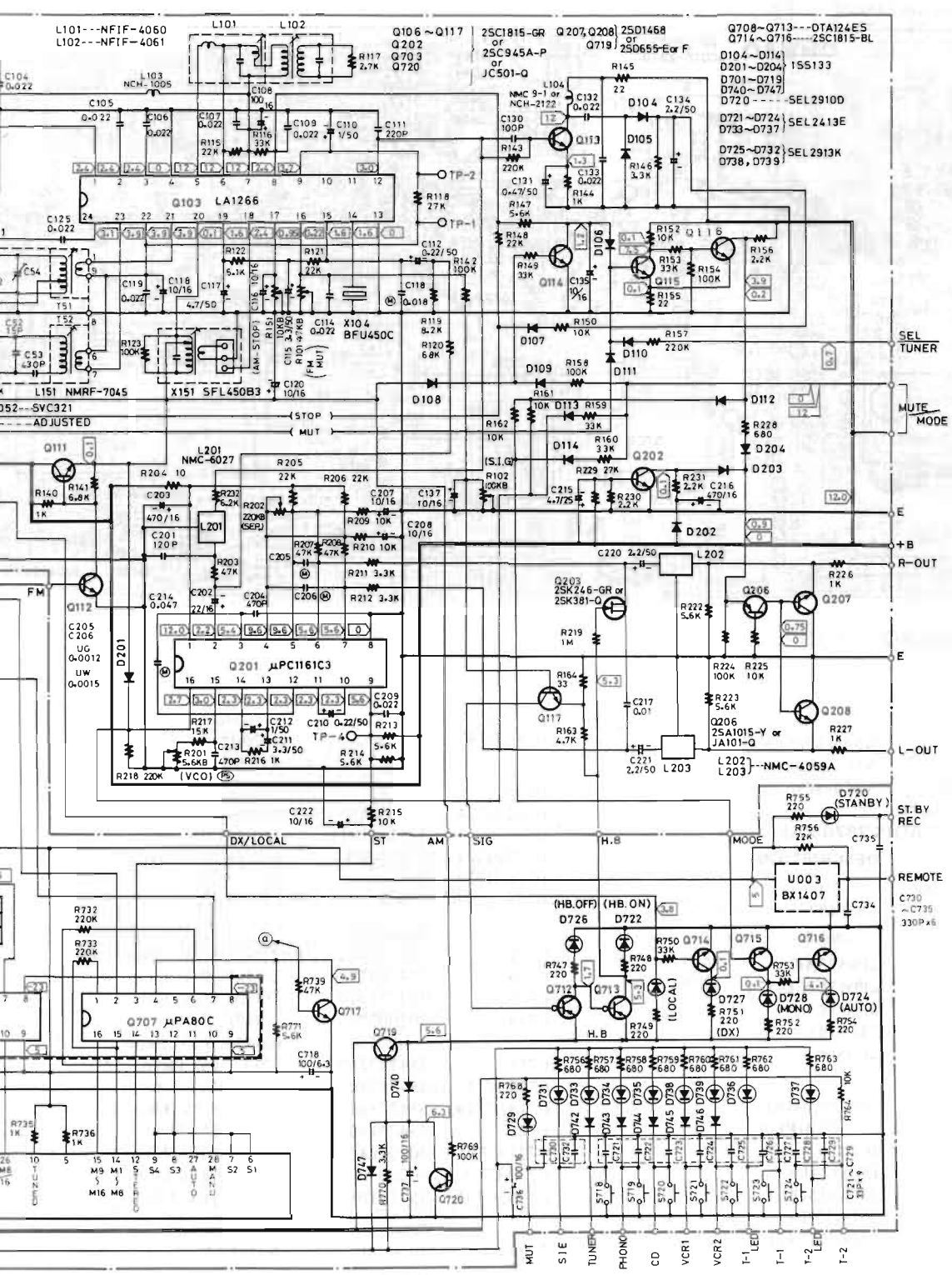

- NOTES
- ALL RESISTORS ARE IN OHMS 1/4WATTS or 1/6WATTS UNLESS OTHERWISE NOTED.
 - ALL CAPACITORS ARE IN μF/50V UNLESS OTHERWISE NOTED.
 - ELECTROLYTIC CAPACITORS (E) ARE IN μF/VV.
 - ALL DIODES ARE 1SS133 UNLESS OTHERWISE NOTED.
 - VOLTAGE (MEASURED WITH V.T.V.M) IS DC VOLTAGE, (NO INPUT SIGNAL).
 - THE COMPONENTS IDENTIFIED BY MARK Δ ARE CRITICAL FOR SAFETY. REPLACE ONLY WITH PART NUMBER SPECIFIED.
 - CIRCUIT IS SUBJECT TO CHANGE FOR IMPROVEMENT.

ONKYO CORPORATION