

ONKYO SERVICE MANUAL

QUARTZ SYNTHESIZED TUNER AMPLIFIER MODEL TX-7540



Black and Silver models

SAFETY-RELATED COMPONENT WARNING!!

COMPONENTS IDENTIFIED BY MARK Δ ON THE SCHEMATIC DIAGRAM AND IN THE PARTS LIST ARE CRITICAL FOR RISK OF FIRE AND ELECTRIC SHOCK. REPLACE THESE COMPONENTS WITH ONKYO PARTS WHOSE PART NUMBERS APPEAR AS SHOWN IN THIS MANUAL.

MAKE LEAKAGE-CURRENT OR RESISTANCE MEASUREMENTS TO DETERMINE THAT EXPOSED PARTS ARE ACCEPTABLY INSULATED FROM THE SUPPLY CIRCUIT BEFORE RETURNING THE APPLIANCE TO THE CUSTOMER.

TABLE OF CONTENTS

Specifications	2
Service procedures	3
Exploded view	4
Parts list	5
Connection diagram of microprocessor	6
Block diagram of IC	7
Adjustment procedures	14
Pc board view/parts list	
Display/preamp./speaker	17
AM/FM tuner and selector circuit	21
Power amplifier	26
Other pc boards	27
Schematic diagram	
Tuner	19
Amp.	23
Block diagram	29
Disassembling procedures	31
Packing view	32

ONKYO
AUDIO COMPONENTS

SPECIFICATIONS

AMPLIFIER SECTION

Power output:	68 watts per channel, min, RMS, at 8ohms, both channels driven, from 20Hz to 20kHz, with no more than 0.04% total harmonic distortion.
Musical Power Output:	2×175 watts at 4 ohms, 1kHz (DIN)
Continuous Power Output:	2×110 watts at 8 ohms, 1kHz (DIN)
Total Harmonic Distortion:	2×100 watts at 4 ohms, 1kHz (DIN) 2×75 watts at 8 ohms, 1kHz (DIN)
IM Distortion:	0.04% at rated power 0.04% at 1 watts output
Damping Factor:	40 at 8 ohms
Frequency Response:	20-30,000Hz ±1dB
RIAA Diviation:	20-20,000Hz ±0.8dB
Sensitivity and Impedance:	Phono: 2.5mV/50 kohms CD: 150mV/50 kohms Tape Play: 150mV/50 kohms Tape Rec: 150mV/3.5 kohms
Phono Overload(MM):	120mV RMS at 1kHz, 0.04% THD.
Signal-to-Noise Ratio:	Phono: 85dB(at 10mV input, A weighted) 75dB(IHF A-202) CD/Tape: 95dB(A weighterd) 80dB(IHF A-202)
Tone controls:	Bass: ±10dB at 100Hz Treble: ±10dB at 10kHz

TUNER SECTION

FM:

Tuning Range:	87.50-108.00MHz(50kHz steps)
Usable Sensitivity:	Mono: 11.2dBf, 1.0 μV, 75ohms 0.9 μV(S/N 26dB, 40kHz Devi.) 75ohms DIN Stereo: 18.0dBf, 2.2 μV, 75ohms 23μV(S/N 46dB, 40kHz Devi.) 75ohms DIN
50dB Quieting Sensitivity:	Mono: 18.0dBf, 2.2 μV, 75ohms Stereo: 37.2dBf, 20μV, 75ohms
Capture Ratio:	1.5dB
Image Rejection Ratio:	85dB
IF Rejection Ratio:	90dB
Signal-to-Noise Ratio:	Mono: 73dB Stereo: 67dB
Selectivity:	50dB DIN(±300kHz, 40kHz dev.)
AM suppression Ratio:	50dB
Harmonic Distortion:	Mono: 0.15% Stereo: 0.25%
Frequency Response:	30-15,000Hz ±1.5dB
Stereo Separation:	45dB at 1kHz 30dB at 100-10,000Hz
Muting Level:	17.2dBf, 4.0μV

AM:

Tuning Range:	522-1611kHz(9kHz steps)
Usable Sensitivity:	30μV
Image Rejection Ratio:	40dB
IF Rejection Ratio:	40dB
Signal-to-Noise Ratio:	40dB
Harmonic Distortion:	0.7%

GENERAL

Dimensions(W × H × D):	435 × 130 × 351mm 17-1/8" × 5-1/8" × 13-13/16"
Weight:	8.8kg., 19.4lbs.

REMOTE CONTROL TRANSMITTER RC-119S

Transmitter: Infrared
 Signal range: Approx. 5meters(16ft.4")
 Power supply: TWO "AA" batteries (1.5V×2)
 Dimensions(W×H ×D): 64×18×176mm
 2-1/2 " ×3/4 " × 7"
 Weight: 140grams 5.0oz.(including batteries)

Specifications and features are subject to change without notice.

SERVICE PROCEDURES

1. Replacing the fuses

For continued protection against fire hazard, replace only with same type and same rating fuse.

Circuit no.	Part no.	Description
F902	252075	2.5A-SE-EAK, Primary
F903	252075	2.5A-SE-EAK, AC outlet
F906	252070	1A-SE-EAK, Secondary

2. Change of FM/AM band step.

With the exception of the models below, a BAND STEP selector switch is not provided.

(FM)

MODEL	BAND STEP	D717, J753	R119
UD	200kHz→50kHz	Additional	15kΩ→24kΩ
UG/UQ	50kHz→200kHz	Eliminated	24kΩ→15kΩ

(AM)

BAND STEP	D716, J754
10kHz→ 9kHz	Additional
9kHz→10kHz	Eliminated

In D716/7 1SS133 (Part No. 223163) is used. In J753/4, a jumper lead must be inserted. R119, with the muting amplitude determined is on the back panel side of FM/AM tuner and selector circuit printed circuit board assembly test points TP-1 and TP-2.

3. Memory preservation

This unit does not require memory preservation batteries. A built-in memory power back-up system preserves contents of the memory during power failures and even when the unit is unplugged. The unit must be plugged in and the power switch turned on and off once in order to charge the back-up system. Note that since this is not a permanent memory the power switch must be turned on and off a few times each month to keep the back-up system operative. The period of time during which memory contents are preserved after power has last been turned off varies depending on climate and placement of the unit. On the average, memory contents are protected over a period of 3 to 4 weeks (a minimum of 2 weeks) after the last time power has been turned off. This period is shorter when the unit is exposed to very high humidity or used in an area with an extremely humid climate.

BACK PANNEL

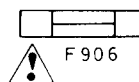

FM/AM TUNER AND SELECTOR
CIRCUIT PC BOARD

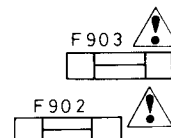

POWER SUPPLY CIRCUIT PC BOARD

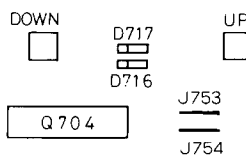

DISPLAY PC BOARD

EXPLODED VIEW

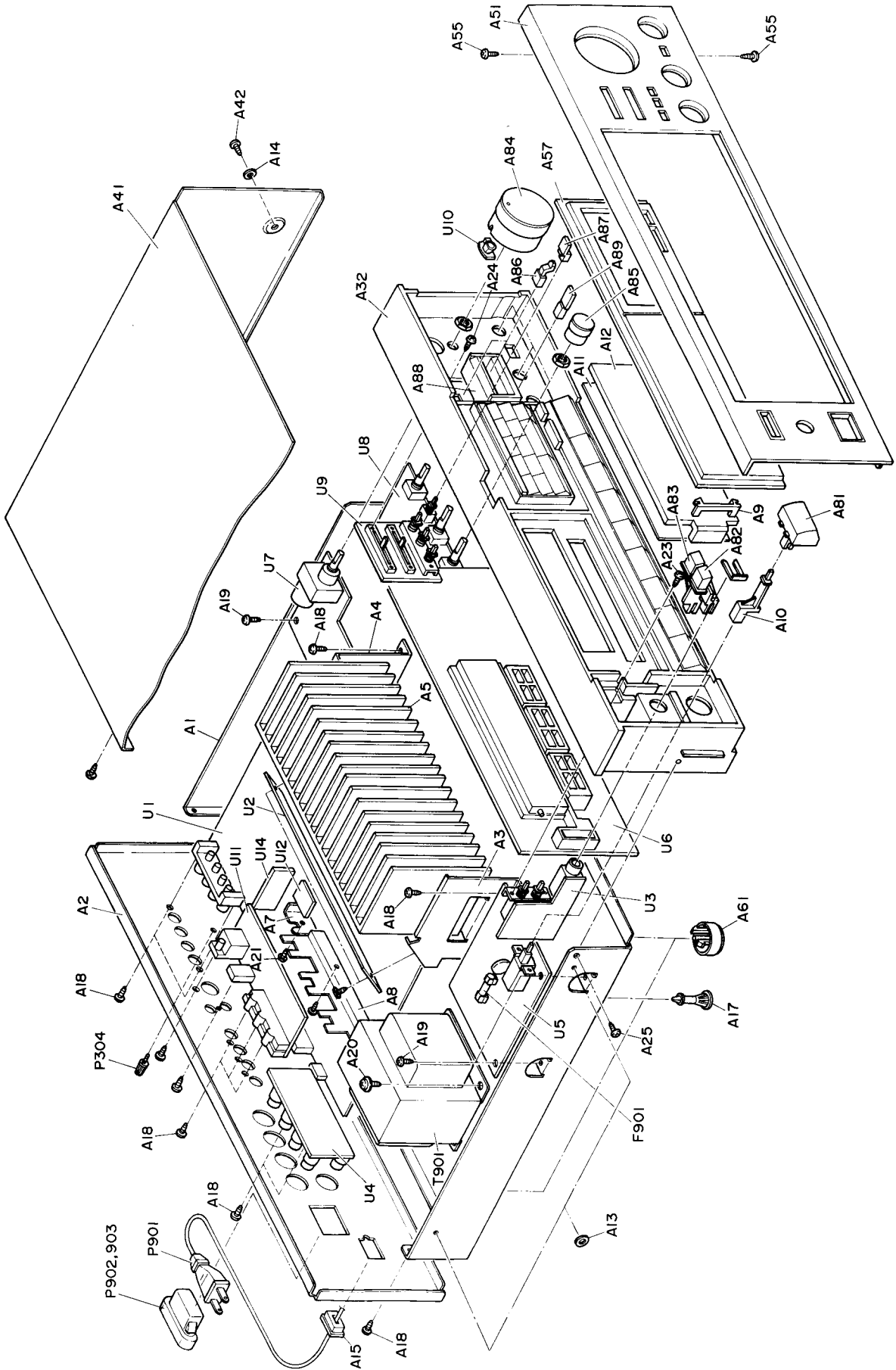

PARTS LIST

REF. NO.	PART NO.	DESCRIPTION	REF. NO.	PART NO.	DESCRIPTION
A1	27100163	Chassis	A88	27190647	Knob SLIDE
A2	27121108	Back panel	A89	27190646	Knob SLIDE <S>
A3	27141261A	Bracket LH		28323369	Knob PUSH
A4	27141262	Bracket RH		28323368	Knob PUSH <S>
A5	27160225	Radiator	F902	252075	2.5A-SE-EAK,Primary fuse
A7	27141263	Bracket SH	F903	252075	2.5A-SE-EAK,AC outlet fuse
A8	27141264	Bracket H	F906	252070	1A-SE-EAK,Secondary fuse
A9	27190644	Holder,dial plate	P304	25060044	3×14mm,Terminal GND
A10	27273098A	Joint,power	P901	253148 or 253150	AS-CEE,Power supply cord
A11	28133198A	Back plate	P902,P903	25050337	NSCT-2P164,AC outlet
A12	28130249	Dial plate	Q521,Q522	2501653, 2201654 or 2201655	2SC3856(O), 2SC3856(Y) or 2SC3856(P),Power amplifier transistor
A13	27270147	Spacer	Q523,Q524	2201663, 2201664 or 2201665	2SA1492(O), 2SA1492(Y) or 2SA1492(P),Power amplifier transistor
A14	870048	3×8×0.8t,Nylon washer	T901	2300304	NPT-992G,Power transformer
A15	27300750	Strainrelief	U1	1A090576-1A	NAAR-3276-1A, FM/AM tuner and selector circuit pc board ass'y
A17	27190524	Holder	U2	1A090577-1	NAAF-3277-1,Power amplifier pc board ass'y
A18	834430088	3TTS+8B(BC),Tapping screw	U3	1A090578-1A	NASW-3278-1A, Speaker switch pc board ass'y
A19	831130088	3TTW+8B,Tapping screw	U4	1A090579-1A	NAETC-3279-1A, Speaker terminal pc board ass'y
A20	830440089	4TTC+8C(BC),Tapping screw	U5	1A090580-1	NAETC-3280-1,Const. voltage circuit pc board ass'y
A21	834430108	3TTS+10B(BC),Tapping screw	U6	1A090581-1A	NADIS-3281-1A, Display pc board ass'y
A22	834230108	3TTS+10B(Ni),Nickel screw	U7	1A090582-1A	NAAF-3282-1A, Volume pc board ass'y
A23	82143006	3P-6FN(BC),Pan head screw	U8	1A090583-1A	NAAF-3283-1A, Preamplifier pc board ass'y
A24	82142004	2P+4F(BC),Pan head screw	U9	1A090584-1	NAAF-3284-1,Switch pc board ass'y
A25	833430080	3TTP+8P(BC),Tapping screw	U10	1A090585-1	NADIS-3285-1,Volume indicator pc board ass'y
A32	27110418A	Front bracket ass'y 	U11	1A090586-1A	NAETC-3286-1A, Video terminal pc board ass'y
A41	28184394	Top cover 	U12	1A090587-1A	NAPS-3287-1A,Power supply circuit pc board ass'y
A42	28184393	Top cover <S>	U14	1A086554-3	NAAF-3054-3,Equalizer amplifier pc board ass'y
A43	834430088	3TTS+8B(BC),Tapping screw			
A44	801230	3STS-8BQ(BC),Tapping screw			
A51	1A094121	Front panel ass'y 			
A52	1A093121	Front panel ass'y <S>			
A55	833430080	3TTP+8P(BC),Tapping screw			
A57	28191466A	Clear plate			
A61	27175142	Leg			
A81	28323241	Knob POWER 			
A82	28323249	Knob POWER <S>			
A83	28323361	Knob SPEAKER A 			
A84	28323360	Knob SPEAKER A <S>			
A85	28323363	Knob SPEAKER B 			
A86	28323362	Knob SPEAKER B <S>			
A87	28323365A	Knob VOLUME 			
A88	28323364A	Knob VOLUME <S>			
A89	28323310	Knob TONE 			
A90	28323309	Knob TONE <S>			
A91	28322925	Knob SLIDE 			
A92	28322924	Knob SLIDE <S>			
A93	28323367	Knob PUSH 			
A94	28323366	Knob PUSH <S>			

NOTE: : Only black model
<S>: Only silver model

NOTE: THE COMPONENTS IDENTIFIED BY MARKA ARE CRITICAL FOR RISK OF FIRE AND ELECTRIC SHOCK. REPLACE ONLY WITH PART NUMBERS SPECIFIED.

CONNECTION VIEW OF MICROPROCESSOR

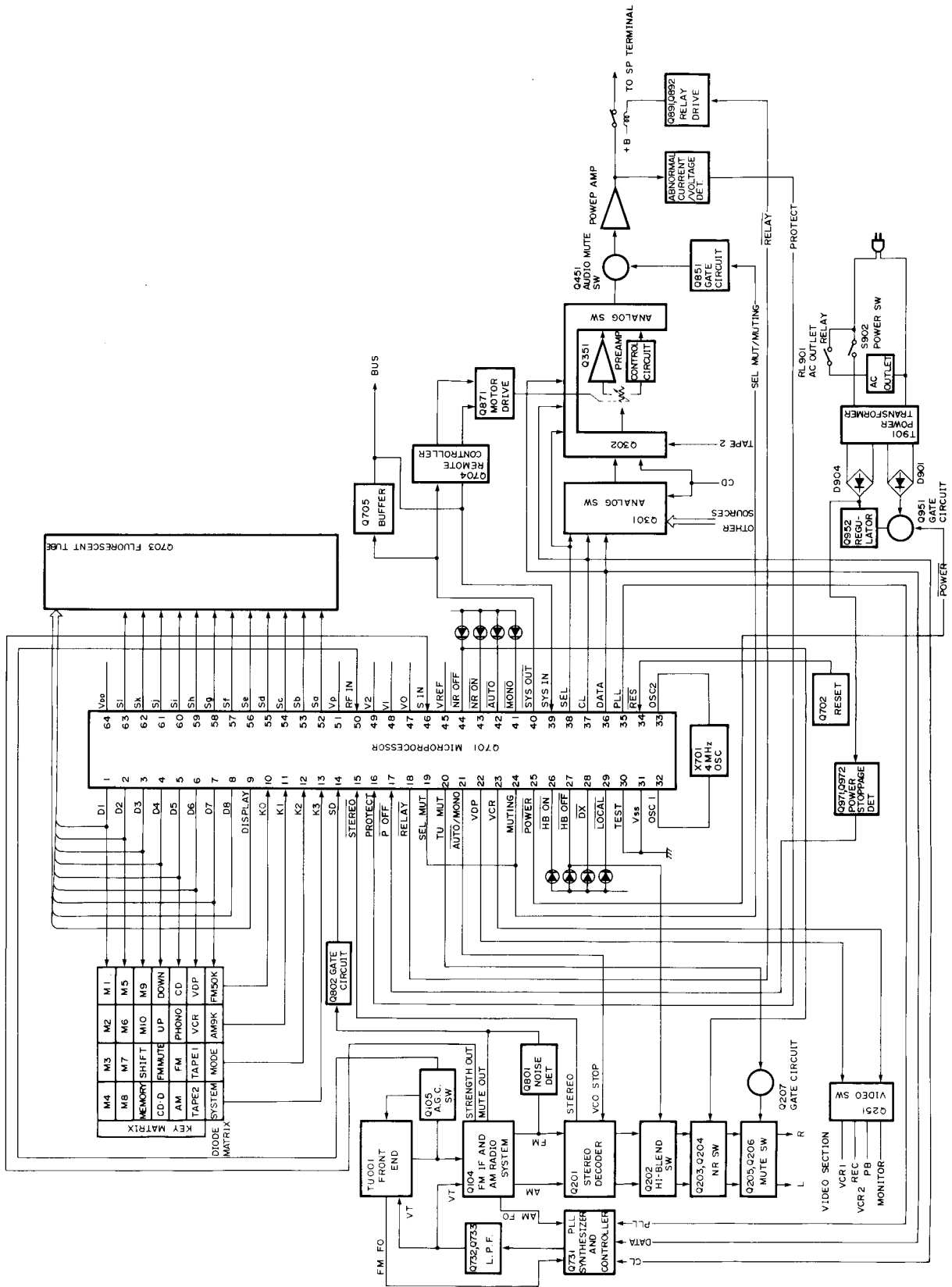

BLOCK DIAGRAM OF ICS

LC6568H-3643 (MICROPROCESSOR)

Terminal Descriptions

Pin No.	Terminal	Description
1	D1	These are the digit and key scan signal terminals. "H" when active.
2	D2	
3	D3	
4	D4	
5	D5	
6	D6	
7	D7	
8	D8	
9	DISPLAY	Display output terminal."H" when active.
10	K0	These are the input terminal for key return signal source and diode matrix."H" when active.
11	K1	
12	K2	
13	K3	
14	SD	Auto stop signal input terminal.Auto tuning stops when this terminal becomes the high level.
15	STEREO	This is the input terminal for detection of the stereo broadcast."L" when active.
16	PROTECT	This is the detection terminal for protection circuit.The speaker relay turns off when this terminal becomes the high level.
17	POWER OFF	This is the input terminal for detection of the stoppage of electric current."L" when the stoppage of electric current.
18	RELAY	This is the output terminal for control of the speaker relay."L" when active.
19	SEL MUTE	This is the muting output terminal when the selector key is operated."H" when active.
20	TU MUTE	This is the output terminal for muting control of tuner section."L" when active.
21	AUTO/MONO	This is the AUTO/MONO switching output terminal. "L" when AUTO.
22	VDP	These are the output terminal for control of video signal.
23	VCR	
24	MUTING	This is the output terminal for muting control. "H" when active.
25	POWER	This is the output terminal for power source.It is "H" for power on.
26	HB ON	This is the output terminal for indication of HI-BLEND ON. "L" when active.
27	HB OFF	This is the output terminal for indication of HI-BLEND OFF. "L" when active.
28	DX	This is the output terminal for indication of DX. "L" when active.
29	LOCAL	This is the output terminal for indication of LOCAL. "L" when active.
30	TEST	Test terminal.Connect to the ground.
31	Vss	Ground terminal.
32	OSC1	Connect to the 4.00MHz ceramic oscillator.
33	OSC2	
34	RES	This is the input terminal for reset. "L" when active
35	PLL	Connect to the terminal CE of PLL IC(LM7001).
36	DATA	This is the serial data output terminal.Connect to the terminal DATA of PLL IC and terminal DI of analog switches. (LC7821/LC7823)
37	CLOCK	This is the serial clock output terminal.Connect to the terminal CI of PLL IC and terminal CL of analog switches.
38	SEL	Connect to terminal SEL of analog switch(LC7821).
39	SYSTEM IN	This is the input terminal for system code. "H" when active.
40	SYSTEM OUT	This is the input terminal for system code. "L" when active.
41	MONO	This is the output terminal for indication of MONO. "L" when active.
42	AUTO	This is the output terminal for indication of AUTO. "L" when active.
43	NR ON	This is the output terminal for indication of NR ON. "L" when active.
44	NR OFF	This is the output terminal for indication of NR OFF. "L" when active.
45	VREF	This is the input terminal for comparator reference voltage.
46	S IN	This is the signal strength input terminal.
47	V0	This is the output terminal for comparator reference voltage.
48	V1	This is the output terminal for comparator reference voltage.
49	V2	This is the output terminal for comparator reference voltage.
50	RF IN	This is the input terminal for control of AGC. "H" when active.
51	VP	Pull-down resistor connection terminal of FIP controller/driver.

Pin No.	Terminal	Description
52	Sa	These are the output terminal for segment signal. "H" when active.
53	Sb	
54	Sc	
55	Sd	
56	Se	
57	Sf	
58	Sg	
59	Sh	
60	Si	
61	Sj	
62	Sk	
63	Sl	
64	VDD	This is the device power source terminal. At the time of operation, the supply is 5V. The internal data memory(RAM) is maintained by means of the super capacitor.

FM50K (FM band setting)

FM50K	Region	Frequency range	Channel space	Reference frequency	IF frequency
1	Europe	87.50 ~ 108.00MHz	50kHz	25kHz	10.7MHz
0	U.S.A.	87.9 ~ 107.9MHz	200kHz	25kHz	10.7MHz

AM9

AM9K	Region	Frequency range	Channel space	Reference frequency	IF frequency
1	Europe	522 ~ 1611 kHz	9kHz	9kHz	450kHz
0	U.S.A.	530 ~ 1620 kHz	10kHz	10kHz	450kHz

Connection of fluorescent tube and microprocessor

ANODE CONNECTION

	8 G(D 8)	7 G(D 7)	6 G(D 6)	5 G(D 5)	4 G(D 4)	3 G(D 3)	2 G(D 2)	1 G(D 1)
a	SLEEP		a	a	a	a	a	a
b	CD DIRECT		b	b	b	b	b	b
c	MEMORY		c	c	c	c	c	c
d	11-20		d	d	d	d	d	d
e	1-10	FM FM MUTE	e	e	e	e	e	e
f	AUDIO MUTE	STEREO	f	f	f	f	f	f
g	-	AM	g	g	g	g	g	g
h	T-2 MONITOR	OFF	-	-	-	h	-	h
i	-	ON	i	-	i	-	-	i
j	-	MIN	j	-	-	-	-	j
k	-	kHz	-	-	k	k	-	k
l	-	MHZ	-	-	DP	-	-	CH
m	PRESET STATION	-	-	-	-	-	-	-
n	SIGNAL FREQUENCY / INPUT SELECTOR	-	-	-	-	-	-	-
o	-	SIGNAL STRENGTH	-	-	-	-	-	-
p	指示灯		-	-	-	-	-	-

μPA81C (BUFFER)

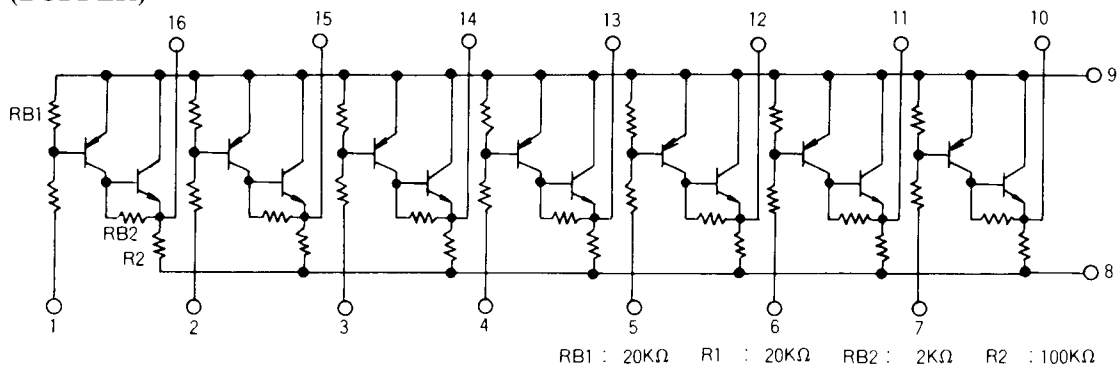

7-BT-95GK (FLUORESCENT TUBE)

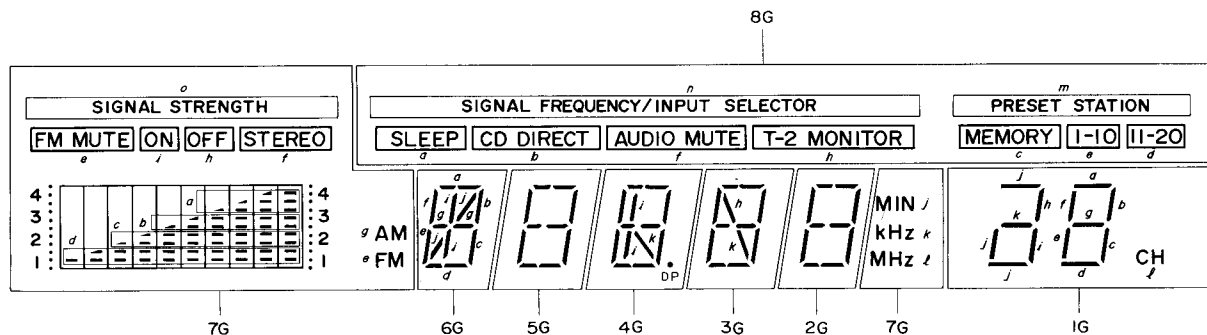

LC7823 (ANALOG SWITCH)

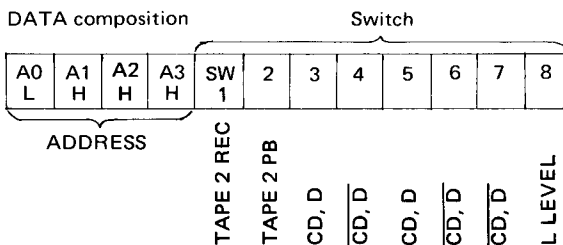
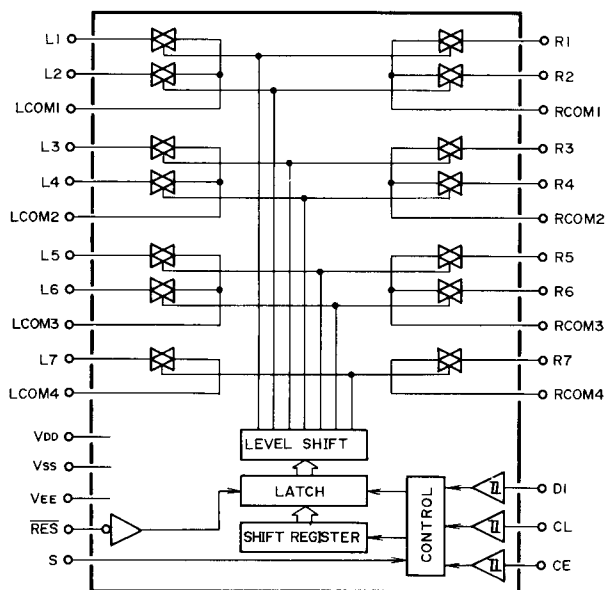

The source becomes ON when the bit of switch becomes high.

Pin No.	Terminal	Description	Pin No.	Terminal	Description
1 (L1)	TAPE 2 REC	Input/output terminals of audio signal of left channel. Control to the inside analog switch at the serial data.	16	VSS	Ground terminal.
2 (L2)	TAPE 2 PB		17	S	Selector terminal.
3	L COM 1		18	RES	Reset terminal. When power is turned ON, the condition of the analog switch is not determined, but when this terminal is "L", all analog switches are OFF.
4 (L3)	CD·D		19	VDD	Power supply terminal. (+15V)
5 (L4)	CD·D		20	R COM 4	Input/output terminals of audio signal of right channel. Control to the inside analog switch at the serial data.
6	L COM 2		21 (R7)	CD·D	
7 (L5)	CD·D		22	R COM 3	
8 (L6)	CD·D		23 (R6)	CD·D	
9	L COM 3		24 (R5)	CD·D	
10 (L7)	CD·D		25	R COM 2	
11	L COM 4		26 (R4)	CD·D	
12	V _{EE}	27 (R3)	CD·D		
13	CE	28	R COM 1		
14	D1	29 (R2)	TAPE 2 PB		
15	CL	30 (R1)	TAPE 2 REC		

LC7821 (ANALOG SWITCH)

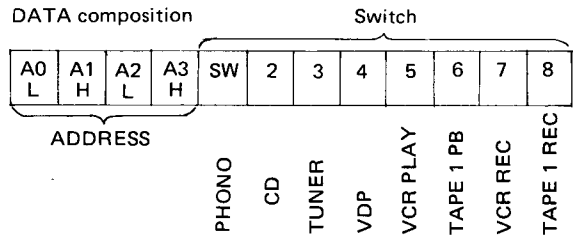
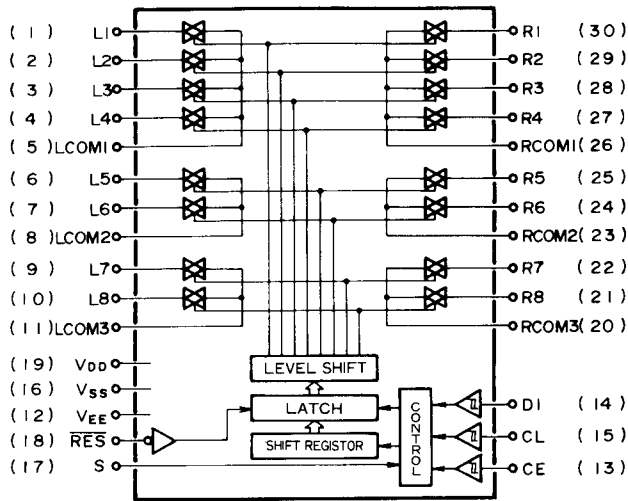

The source becomes ON when the bit of switch becomes high.

Pin No.	Terminal	Description	Pin No.	Terminal	Description		
1	PHONO	Input/output terminals of audio signal of left channel. Control to the inside analog switch at the serial data.	16	Vss	Ground terminal.		
2	CD		17	S	Selector terminal.		
3	TUNER		Reset terminal. When power is turned ON, the condition of the analog switch is not determined, but when this terminal is "L", all analog switches are OFF.	18	RES		
4	VDP			Power supply terminal. (+15V)	19	VDD	
5	L COM 1				Input/output terminals of audio signal of right channel. Control to the inside analog switch at the serial data.	20	R COM 3
6	VCR PB					21	TAPE 1 REC
7	TAPE 1 PB					22	VCR REC
8	L COM 2		23	R COM 2			
9	VCR REC		24	TAPE 1 PB			
10	TAPE 1 REC		25	VCR P			
11	L COM 3		26	R COM 1			
12	Vss	27	VDP				
13	CE	28	TUNER				
14	DI	29	CD				
15	CL	30	PHONO				

μPC1161C3 (STEREO DECODER)

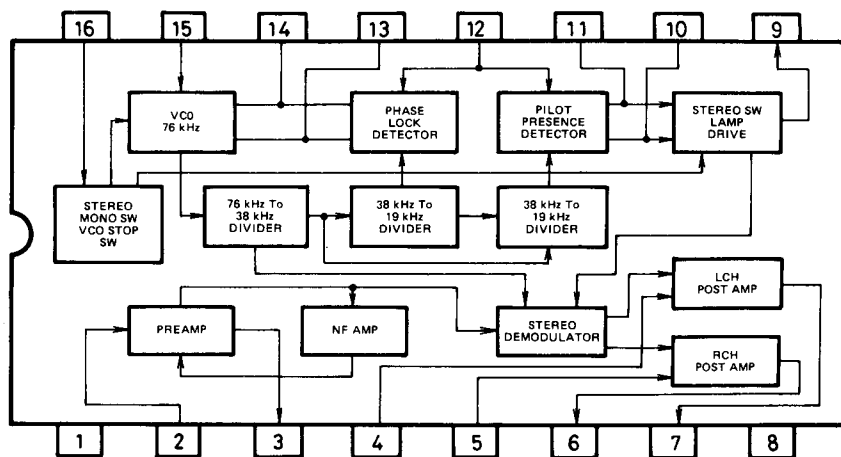

LM7001 (PLL SYNTHESIZER AND CONTROLLER)

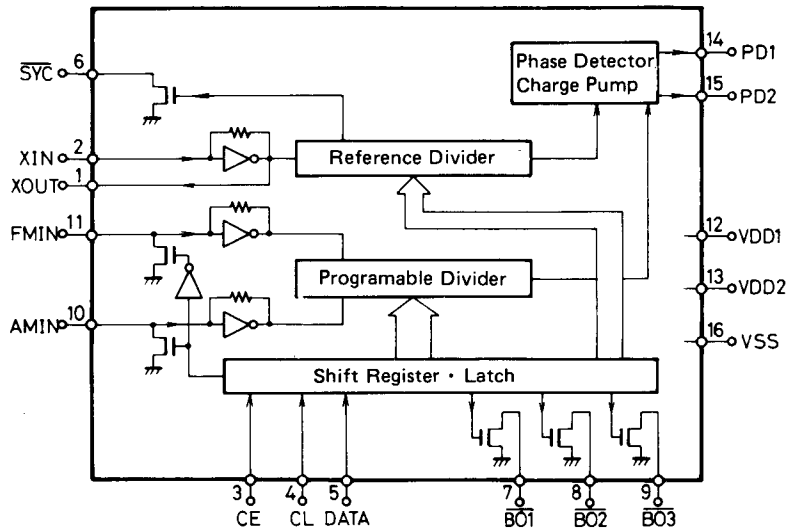

Pin No.	Terminal	Description
1	XOUT	Connect to the 7.2 MHz crystal oscillator.
2	XIN	
3	CE	Chip enable terminal. Connect to the PLL terminal of LC6568H-3643.
4	CL	Serial clock input terminal. Connect to the CLOCK terminal of LC6568H-3643.
5	DATA	Serial data input terminal. Connect to the DATA terminal of LC6568H-3643.
6	SYN	Not used.
7	BO1	Phono control signal output terminal. "L" when phono.
8	BO2	FM control signal output terminal. "L" when FM.
9	BO3	AM control signal output terminal. "L" when AM.
10	AMIN	AM local oscillator input terminal.
11	FMIN	FM local oscillator terminal.
12	VDD 1	Power supply terminal for back-up.
13	VDD 2	Power supply terminal.
14	PD1	Charge pump output of the phase detector which constitutes the PLL. High level is output when the divided local oscillator frequency is high than the reference frequency. In the opposite case, low level is output. Floating occurs when the frequencies matched. The output is applied to the variable capacitor diode in the local oscillator through the low pass filters.
15	PD2	
16	Vss	Ground terminal.

μPC4570C (OP AP)

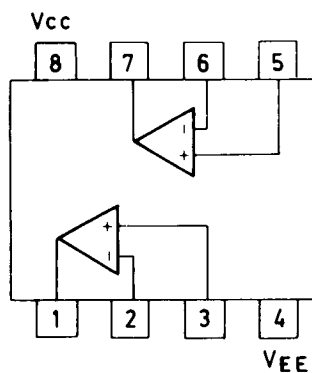

LC6527C-3608 (REMOTE CONTROLLER)

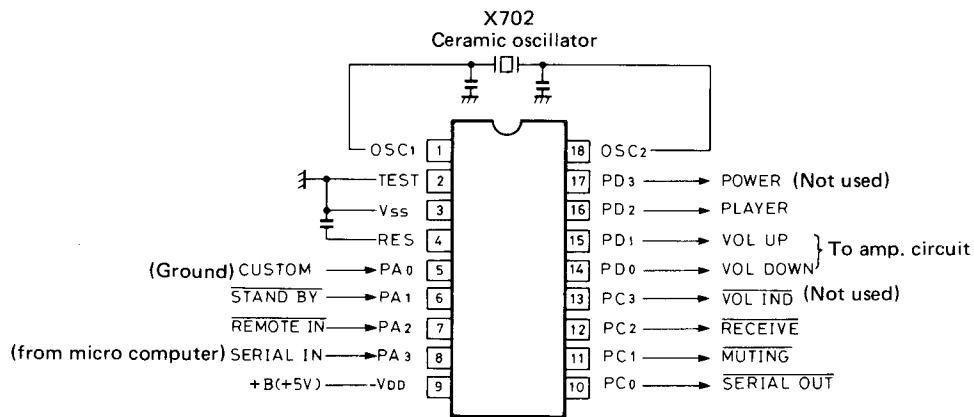
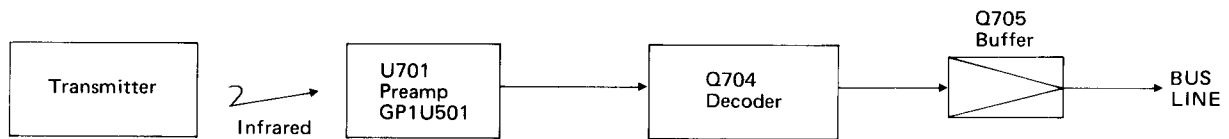

Connection diagram

Terminal No.	Symbol	Terminal	Description
1 18	OSC1 OSC2	OSC	Connect to the 1MHz ceramic oscillator.
2	TEST	TEST	Test terminal. Connect to the ground.
3	Vss	GND	Ground terminal.
4	RES	RES	Reset terminal.
5	PA0	CUSTOM	The custom code for decode is selected at this terminal. For U.S.A., the level is low.
6	PA1	STANDBY	Terminal for STANDBY detection. During low input, only the POWER code is decoded.
7	PA2	REMOTE IN	Signal input terminal for remote control preamp. Active low.
8	PA3	SERIAL IN	
9	VDD	+B	Power supply terminal.
10	PC0	SERIAL OUT	Output at this terminal are the custom code (16 bit) remote control code input to REMOTE IN, data code (8 bit), and the serial code (12 bit) that has been converted corresponding to the decoded data code (8 bit).
11	PC1	MUTING	At this terminal, the audio muting code that is input is inverted for each L/H. When power is ON, the level is high.
12	PC2	RECEIVE	This is the display output for remote control reception. Output is low when decoded code is being received.
13	PC3	VOL IND	During output of VOLUME UP/DOWN, a pulse (┌───┐└───┘; T = 0.3ms) is output.
14	PD0	VOL DOWN	When the volume DOWN code is input, a high pulse of 120ms is output.
15	PD1	VOL UP	When the volume UP code is input, a high pulse of 120ms is output.
16	PD2	PLAYER	When the player PLAY/REJECT is input, a high pulse of 200ms is output.
17	PD3	POWER	The power code input inverts the L/H. Level is high for power being turned ON.

LA1266 (FM IF AND AM RADIO SYSTEM)

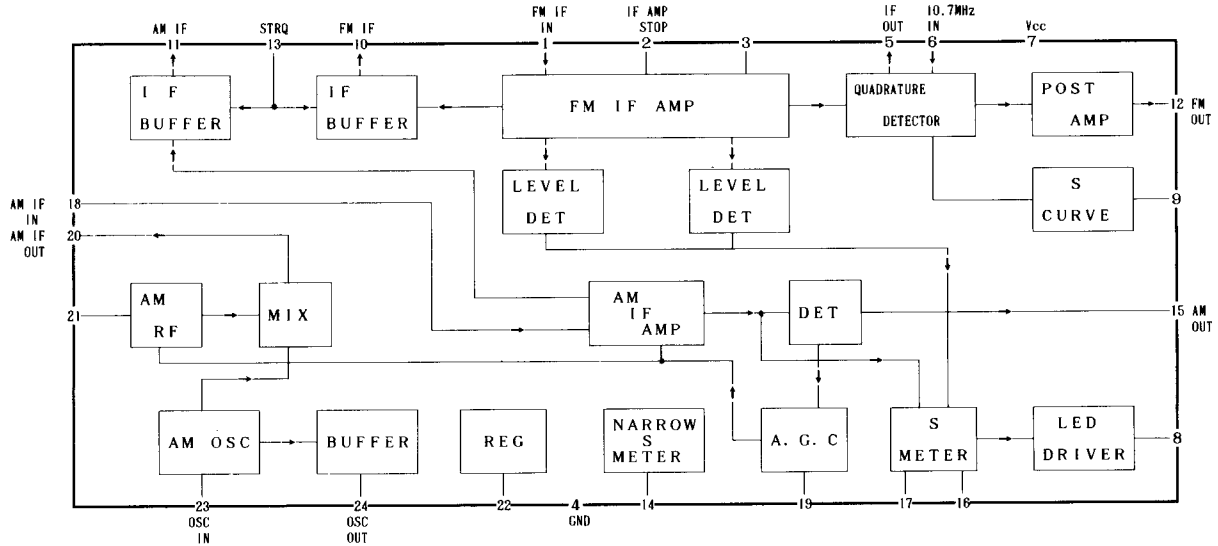

LB1630 (MOTOR DRIVE)

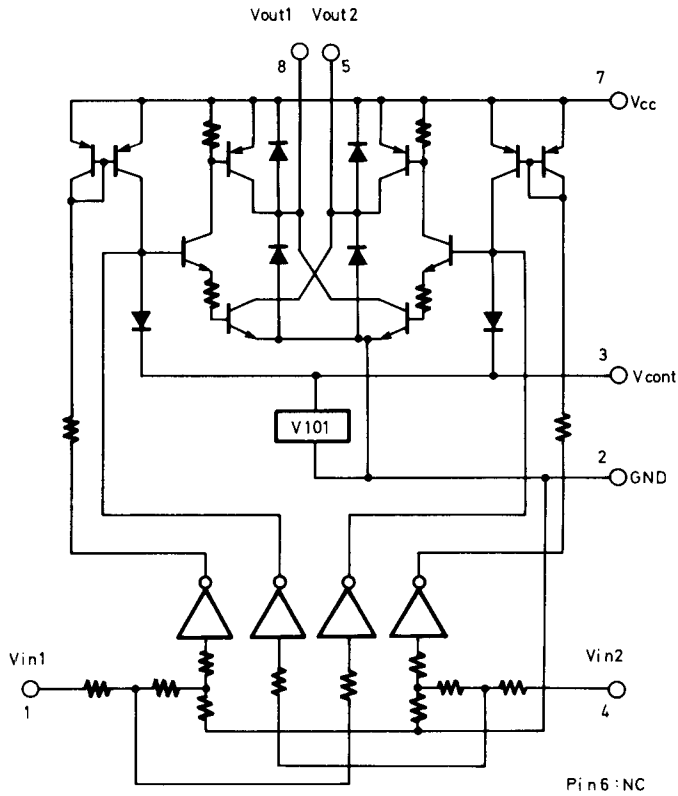

IN1	IN2	OUT1	OUT2	MOTOR
H	L	H	L	Normal
L	H	L	H	Reverse
H	H	OFF	OFF	Wait
L	L	OFF	OFF	Wait

NJM4558D/4560D/DX (OP AMP)

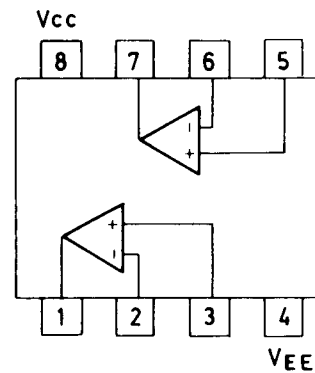

4066B (ANALOG SWITCH)

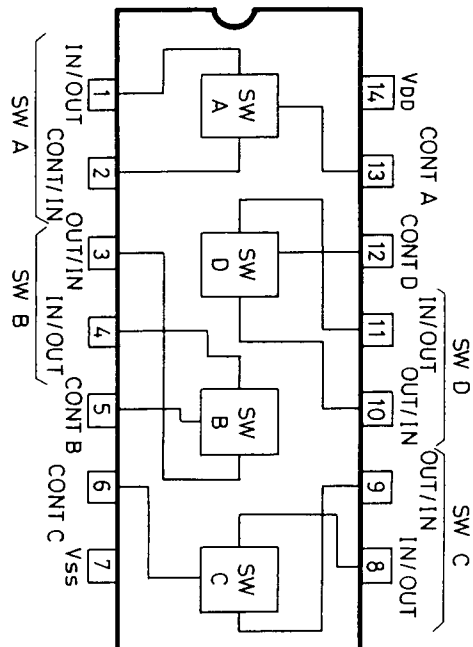

ADJUSTMENT PROCEDURES

Preparation

• Input

FM mono: 1kHz, 75kHz devi., 60dB/ μ V

FM stereo: 1kHz, L+R 67.5kHz devi.: Pilot signal 19kHz
7.5kHz devi.

AM: 400Hz, 30% mod.,

• Output

Connect the non-inductive type resistor of 8 ohms to the speaker terminal A of left and right channels unless otherwise noted.

• Standard knob position

TAPE MONITOR	SOURCE
VOLUME	Maximum
BASS/TREBLE/BALANCE	Center
VCR 2 MODE	STEREO
SPEAKER	A
SIMULATED STEREO	OFF
DYNAMIC BASS EXPANDER	OFF
STEREO IMAGE EXPANDER	OFF
SELECTIVE TONE CONTROL	OFF

Amplifier section

1. Idling current adjustment

Connect the DC voltmeter to the terminals IID and VCT on the power amplifier pc board.

Adjust the semi-fixed resistors R533 and R534 so that the indication of voltmeter is 7.5 ± 1.5 mV.

Notes: VOLUME Maximum, Open load,
Adjust after switching on for 5 minutes.

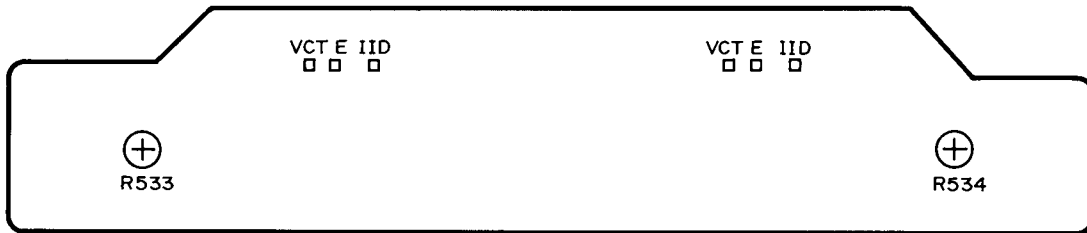

Power amplifier pc board

FM section

Item	Step	Connection of instrument	FM SG output	Stereo modulator output	Turning dial setting	Output indicator	Adjustment	Adj
FM IF	1	Fig. 1	99.1MHz 1kHz, 75kHz devi. 65dBf (60dB)	-	99.1MHz	DC voltmeter	L101	0V ±
	2					AC voltmeter	IF on the front end	Maxim
	3					Distortion analyzer	L102	Minim
Stereo indicator level	1	Fig. 3	99.1MHz 17.2dBf (12dB) Ext. modulation	L + R : 1kHz 67.5kHz devi.	99.1MHz	Stereo indicator	R101	Light
	2		99.1MHz 16.2dBf (11dB) Ext. modulation	Pilot signal 19kHz 7.5kHz devi.				Light
VCO		Fig. 2	99.1MHz 1kHz, 75kHz devi. 65dBf (60dB)	-	99.1MHz	Frequency counter	R201	19kHz
Stereo Distortion		Fig. 3	99.1MHz 65dBf (60dB) Ext. modulation	L or Rch. 1kHz	99.1MHz	Distortion analyzer	IF on the front end	Minim
Stereo Separation	1	Fig. 3	99.1MHz 65dBf (60dB) Ext. modulation	Lch. 1kHz	99.1MHz	Rch. AC voltmeter	R202	Minim
	2			Rch. 1kHz				Lch. AC voltmeter
Hi-blend level		Fig. 3	99.1MHz 35.2dBf (30dB) 1kHz, 75kHz devi.	-	99.1MHz	Hi-blend indicator	R102	Light

AM section

Step	AM SG output	Tuned frequency	Output indicator	Adjustment point	Adjust for
1		522kHz	Digital DC voltmeter	OSC on RF block	1.3V ± 0.1V
2	603kHz 400Hz 30% mod. 60dB/m	603kHz	AC voltmeter	RF on RF block	Maximum
3	999kHz 400Hz 30% mod. 60dB/m	999kHz	AC voltmeter	L152	Maximum
4	Same as above	999kHz	First signal indicator	R151	Light on

Reference specification
FM Tuned voltage

Auto stop level

AM Tuned voltage

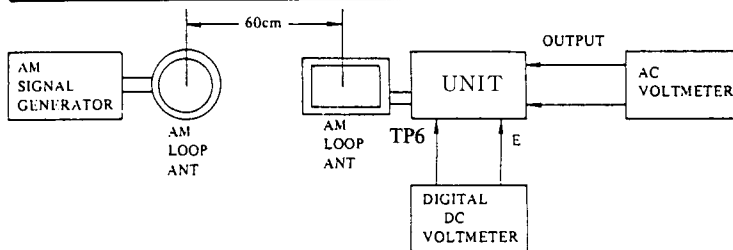

Stereo modulator output	Turning dial setting	Output indicator	Adjustment	Adjust for	Remarks
-	99.1MHz	DC voltmeter	L101	0V ± 20mV	Mode switch: MONO Repeat the steps 1 and 3 until no further adjustment is necessary
		AC voltmeter	IF on the front end	Maximum	
		Distortion analyzer	L102	Minimum	
L + R : 1kHz 67.5kHz devi. Pilot signal 19kHz 7.5kHz devi.	99.1MHz	Stereo indicator	R101	Light on Light off	Mode switch: STEREO
-	99.1MHz	Frequency counter	R201	19kHz ± 10Hz	
L or Rch. 1kHz	99.1MHz	Distortion analyzer	IF on the front end	Minimum	Don't turn more than ± 180 :
Lch. 1kHz	99.1MHz	Rch. AC voltmeter	R202	Minimum	Maximum and same separation
Rch. 1kHz		Lch. AC voltmeter		Minimum	
-	99.1MHz	Hi-blend indicator	R102	Light off	

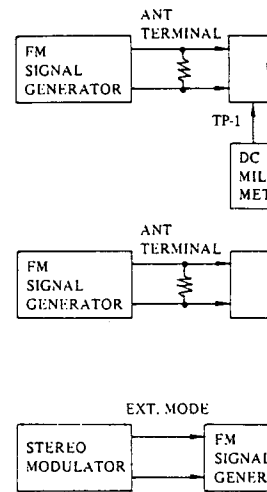

Adjustment point	Adjust for
OSC on RF block	1.3V ± 0.1V
RF on RF block	Maximum
L152	Maximum
R151	Light on

Reference specifications

- FM Tuned voltage
 - 87.5MHz 2.0 ± 0.5V
 - 108.0MHz 7.7 ± 0.5V
- Auto stop level
 - AM: Less than 66dB/m
 - FM: Less than 17dBμ
- AM Tuned voltage
 - 522kHz 1.3 ± 0.5V
 - 1611kHz 8.0 ± 0.5V

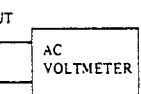

FM/AM selector board

Item	Adjust for	Remarks
	0V ± 20mV	Mode switch: MONO Repeat the steps 1 and 3 until no further adjustment is necessary
	Maximum	
	Minimum	
	Light on	Mode switch: STEREO
	Light off	
	19kHz ± 10Hz	
	Minimum	Don't turn more than ± 180°
	Minimum	Maximum and same separation
	Minimum	
	Light off	

Frequency specifications	
Rated voltage	87.5MHz 2.0 ± 0.5V 108.0MHz 7.7 ± 0.5V
Output level	AM: Less than 66dB/m FM: Less than 17dBμ
Rated voltage	522kHz 1.3 ± 0.5V 1611kHz 8.0 ± 0.5V

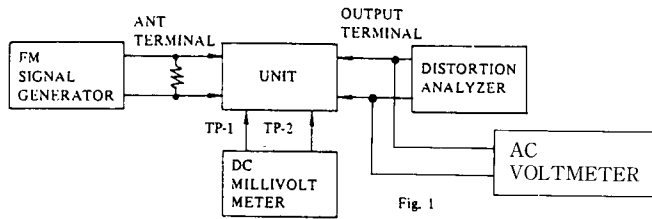
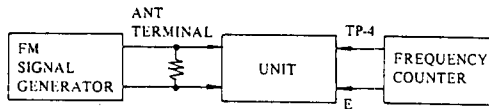

Fig. 1



Use the high impedance probe. (10:1)

Fig. 2

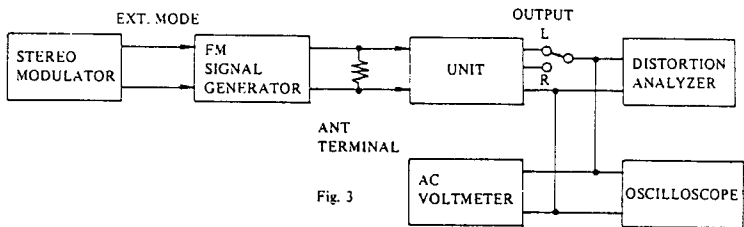
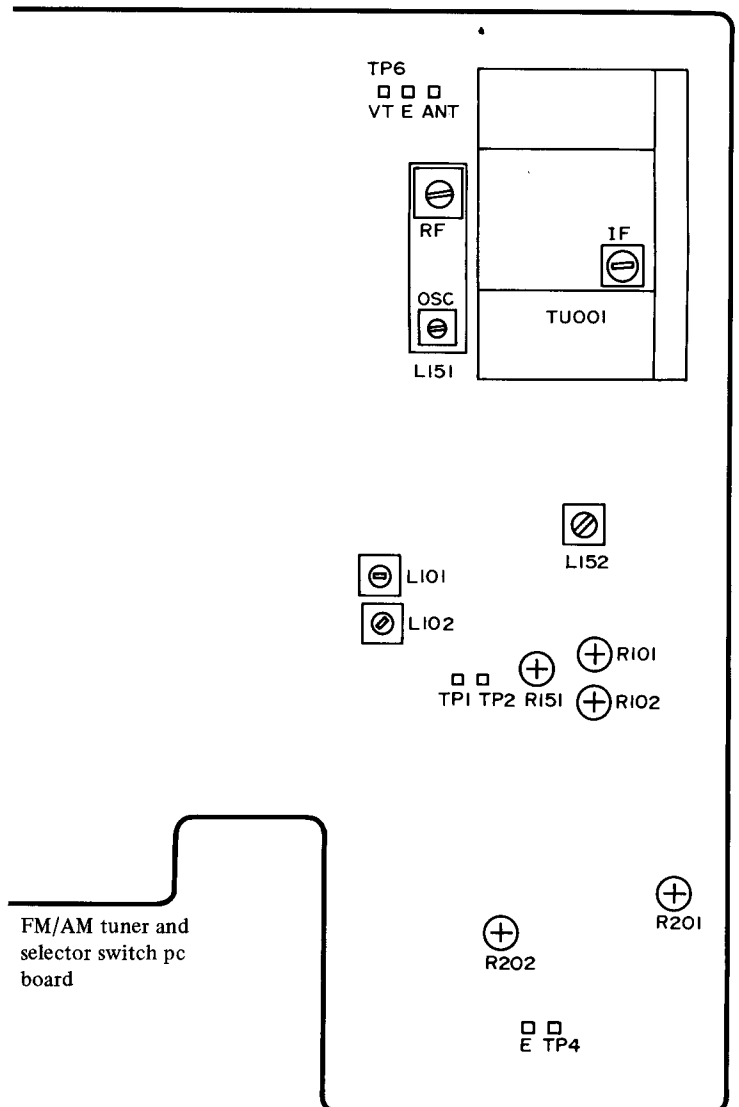
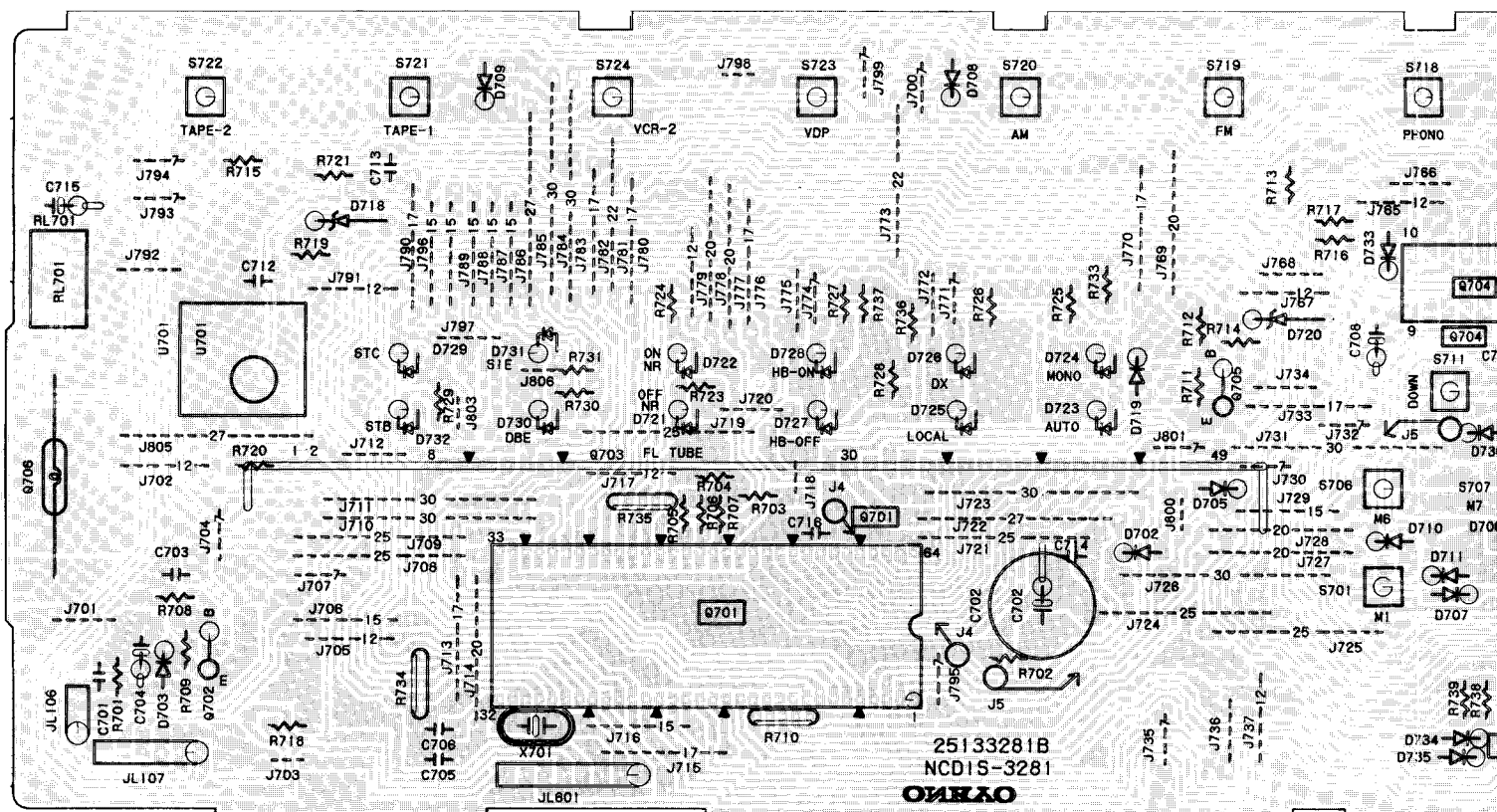

Fig. 3



FM/AM tuner and selector switch pc board

PRINTED CIRCUIT BOARD VIEW FROM BOTTOM SIDE



DISPLAY PC BOARD

PRINTED CIRCUIT BOARD-PARTS LIST

DISPLAY PC BOARD(NADIS-3281-1A)

CIRCUIT NO. PART NO. DESCRIPTION

CIRCUIT NO.	PART NO.	DESCRIPTION
ICs		
U701	24130001	GP1U501S
Q701	22240153	LC6568H-3643
Q704	22240150	LC6527C-3608
Transistors		
Q702	2211255 or 2210746	2SC1815(GR) or 2SC945A(P)
Q705	2211455 or 2210803	2SA1015(GR) or 2SA733(P)
Fluorescent tube		
Q703	212054	7-BT-95GK
Lamp		
Q706	210064A	6.3V,0.25A
Diodes		
D702-D715	223163	1SS133
D716,D717	223163	1SS133
D718,D720	224650822, 224150822 or 224450822	05AZ8.2Y, HZ8.2EB2 or MTZ8.2B
D719	223163	1SS133
D720	224150562 or 224650562	05AZ5.6Y or HZ5.6EB2
D733-D735	223163	1SS133
L.E.Ds		
D721,D723	225137CG,	SEL2413ECG,
D725,D727	225137DG or	SEL2413EDG or
D729-D731	224137DY	SEL2413EDY
D722,D724	225142	SEL2913K
D726,D728	225142	SEL2913K
D732	225141	SEL2213C
Osc. elements		
X701	3010099	CSA4.00MG,Ceramic
X702	3010119	CSB-1000D,Ceramic
Capacitors		
C702	3020027 or 3000051	0.047F,5.5V or 0.047F,5.5V,Super
C704	354780109	1 μ F,50V,Elect.
C707,C715	354782299	0.22 μ F,50V,Elect.
C708	354741009	10 μ F,16V,Elect.
Resistors		
R710	49163473404	47kohm \times 4, 1/10W,Network
R734,R735	49163104404	100kohm \times 4, 1/10W,Network
Switches		
S701-S724	25035548	NPS-111-S510
Relay		
RL701	25065298	NRL-1P1A-DC12-40
Holder		
JL801	27190643A	L.E.D
SPEAKER SWITCH PC BOARD(NASW-3278-1A)		
CIRCUIT NO.	PART NO.	DESCRIPTION
R549,R550	442520474	4.7ohm,1/2W,Metal oxide film resistors
R551,R552	441623914	390ohm,1W,Metal oxide film resistors
S502,S503	25035517	NPS-222-L479,Push switch
P503	25045139	HLJ-0540-01-010,Stereo headphone terminal

M BOTTOM SIDE

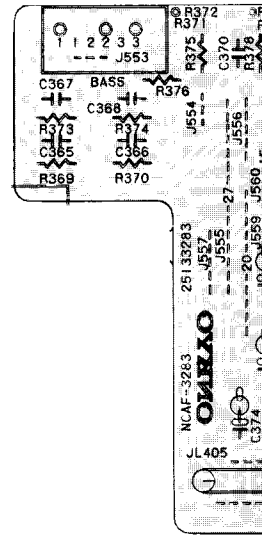
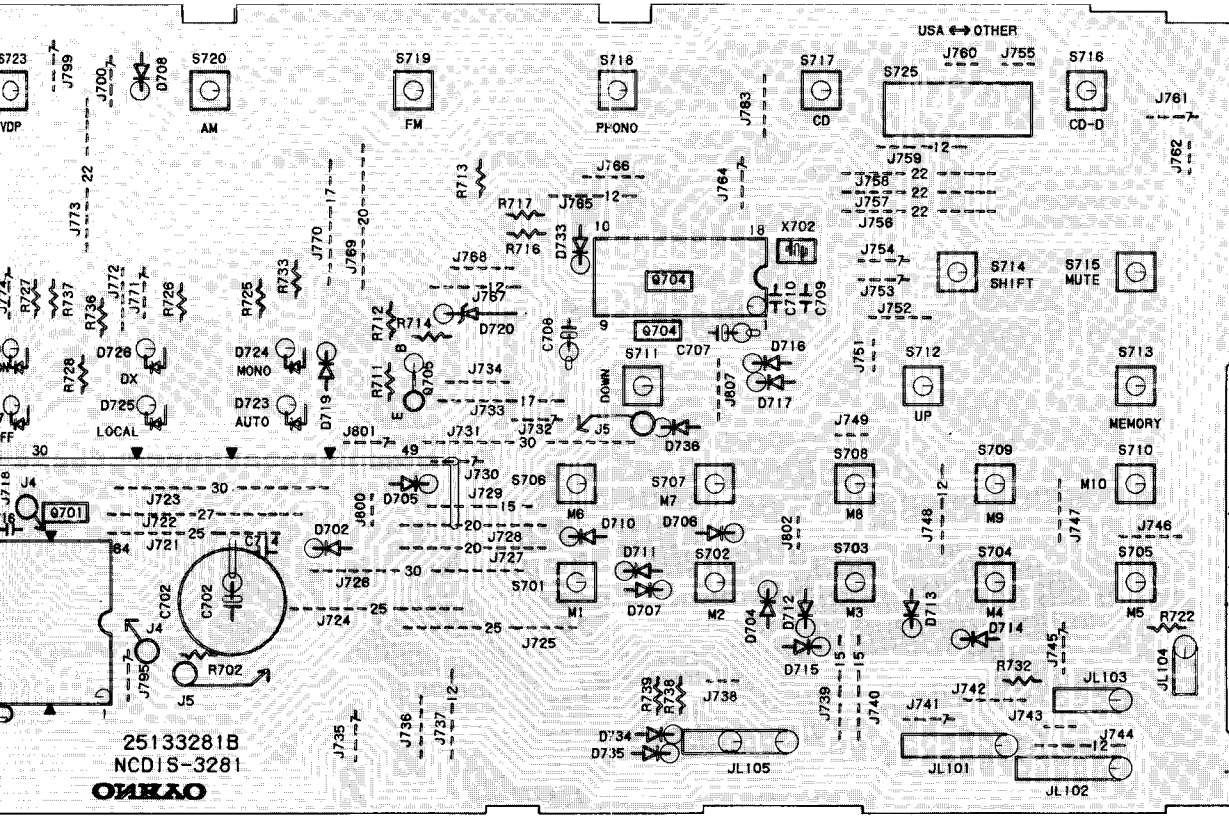

PRE

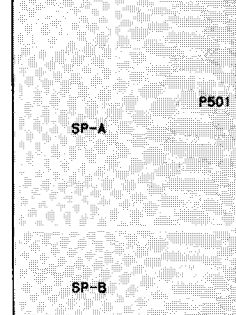

SPEAK

SPE

PREAMPLIFIER PC BOARD(NAAF-3283-1A)

CIRCUIT NO.	PART NO.	DESCRIPTION
		ICs
Q352	222579 or 222570	NJM4560D or NJM4560DX
Q353	222465	NJM4558D
		Transistors
Q851	2212600	D7A124ES
Q853	221281	D7C114YS
		Diodes
D351	224650623 or 224150623	HZ6.2EB3 or 05AZ6.2Z
D352,D353	223163	1SS133
		Capacitors
	C359,C360	354780229 2.2 μ F,50V,Elect.
	C363,C364	354741009 10 μ F,16V,Elect.
	C367,C368	352983396 0.33 μ F,50V,Non-polar elect.
	C373,C374	354780229 2.2 μ F,50V,Elect.
	C375-C378	354781099 0.1 μ F,50V,Elect.
	C389	354780229 2.2 μ F,50V,Elect.
	C390,C392	354781099 0.1 μ F,50V,Elect.
	C393,C851	354780339 3.3 μ F,50V,Elect.
		Resistors
	R371,R372	5104216 N14RLC50KC22Z, Variable,Bass
	R379,R380	5104216 N14RLC50KC22Z, Variable,Treble
	R451	5104225 N11RGLC250KW22Z, Variable,Balance
		Switch
S354	25035590	NPS-122-L552

SPEAKER TERMINAL PC BOARD(NAETC-3279-1A)

CIRCUIT NO.	PART NO.	DESCRIPTION
P501,P502	25060110	NTM-4PDMN44,Speaker terminals

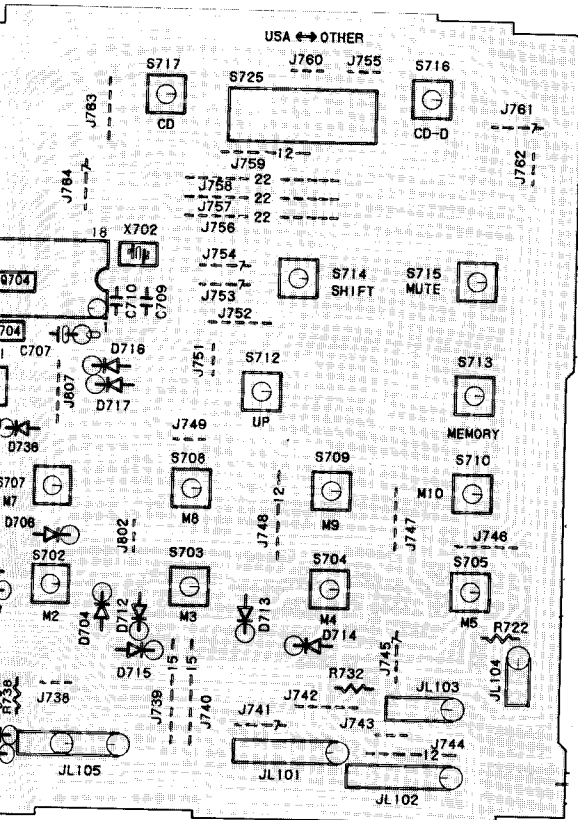

PREAMPLIFIER PC BOARD(NAAF-3283-1A)

CIRCUIT NO. PART NO. DESCRIPTION

CIRCUIT NO.	PART NO.	DESCRIPTION
Q352	222579 or 222570	NJM4560D or NJM4560DX
Q353	222465	NJM4558D
Transistors		
Q851	2212600	DTA124ES
Q853	221281	DTC114YS

Diodes

D351	224650623 or 224150623	HZ6.2EB3 or 05AZ6.2Z
D352, D353	223163	1SS133

Capacitors

C359, C360	354780229	2.2 μ F, 50V, Elect.
C363, C364	354741009	10 μ F, 16V, Elect.
C367, C368	352983396	0.33 μ F, 50V, Non-polar elect.
C373, C374	354780229	2.2 μ F, 50V, Elect.
C375-C378	354781099	0.1 μ F, 50V, Elect.
C389	354780229	2.2 μ F, 50V, Elect.
C390, C392	354781099	0.1 μ F, 50V, Elect.
C393, C851	354780339	3.3 μ F, 50V, Elect.

Resistors

R371, R372	5104216	N14RLC50KC22Z, Variable, Bass
R379, R380	5104216	N14RLC50KC22Z, Variable, Treble
R451	5104225	N11RGLC250KW22Z, Variable, Balance

Switch

S354	25035590	NPS-122-L552
------	----------	--------------

SPEAKER TERMINAL PC BOARD(NAETC-3279-1A)

CIRCUIT NO.	PART NO.	DESCRIPTION
P501, P502	25060110	NTM-4PDMN44, Speaker terminals

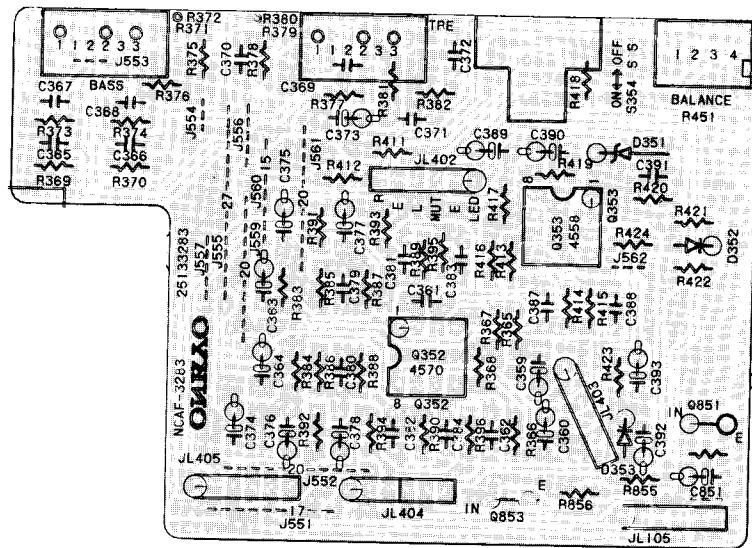

PREAMPLIFIER PC BOARD

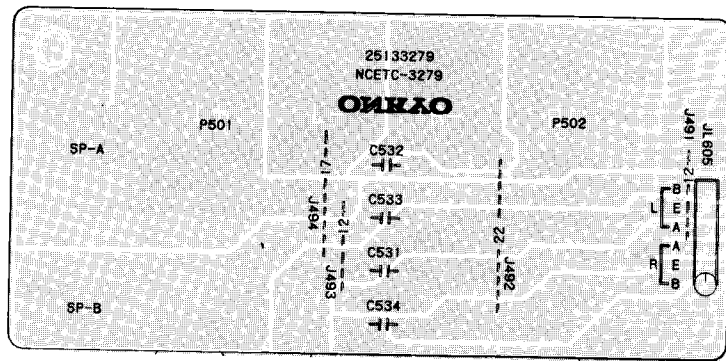

SPEAKER TERMINAL PC BOARD

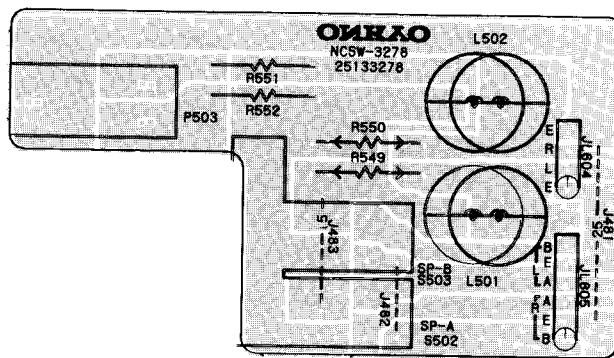

SPEAKER SWITCH PC BOARD

SCHEMATIC DIAGRAM

-TUNER SECTION-

A

B

C

D

E

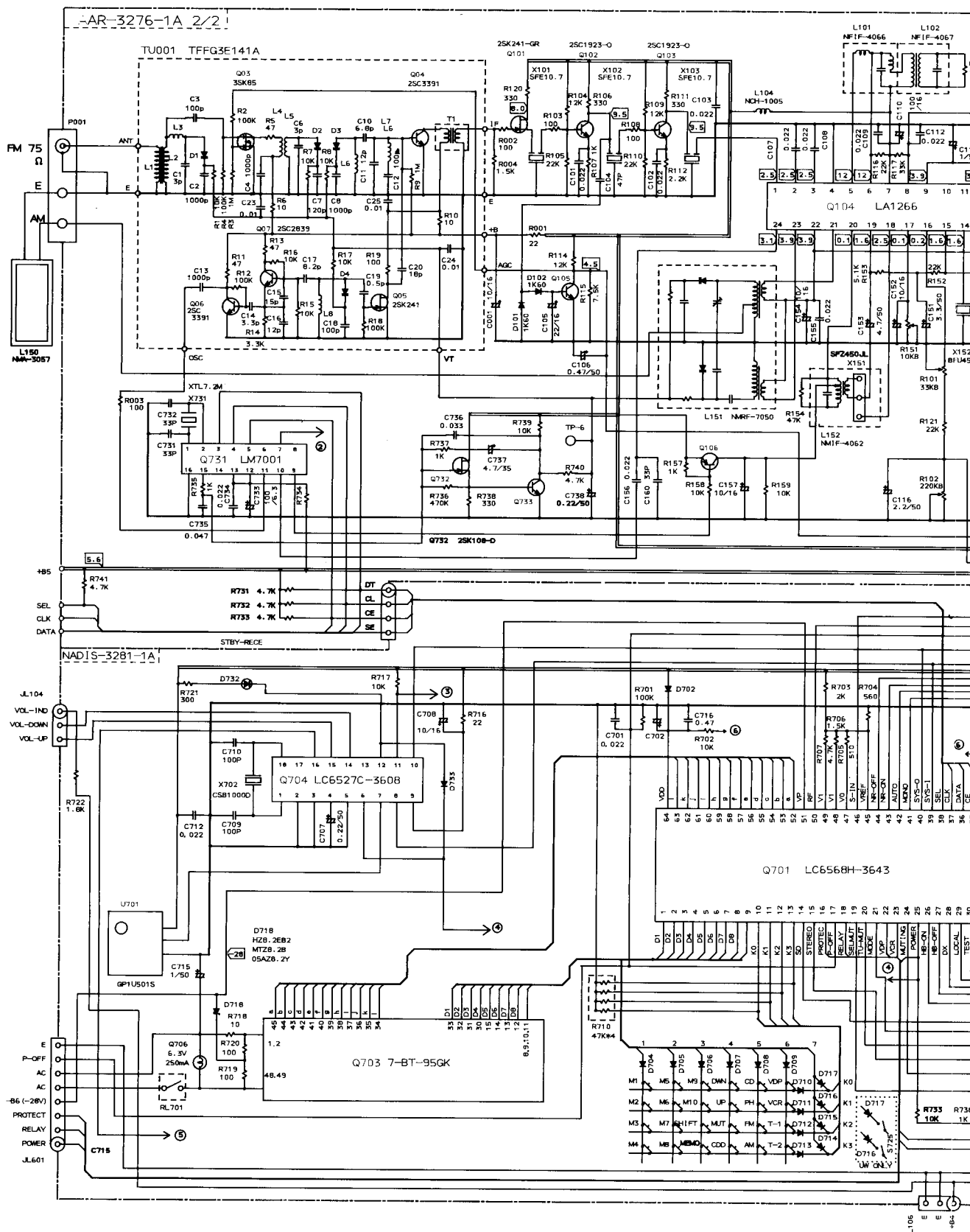

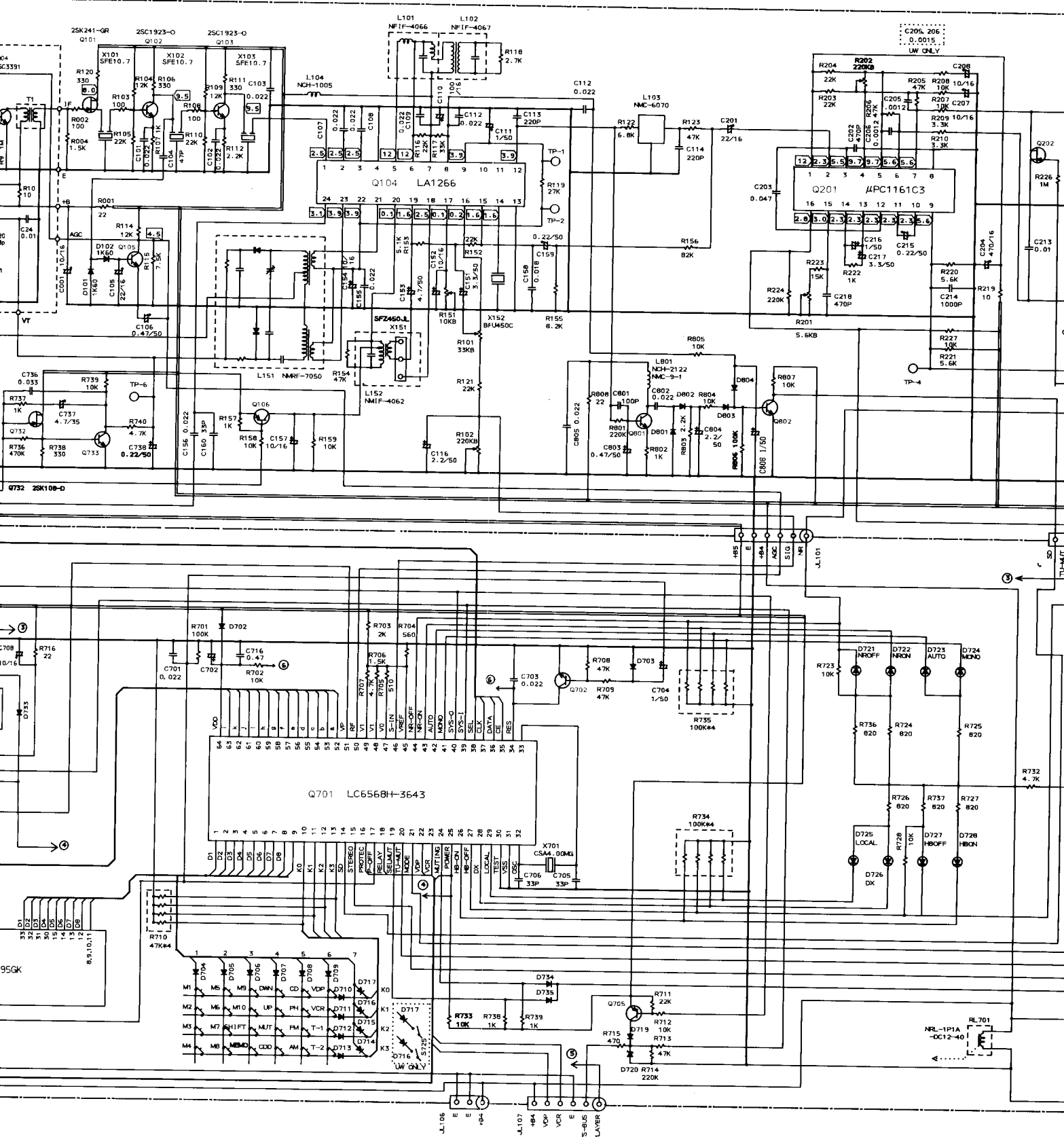

4

5

6

7

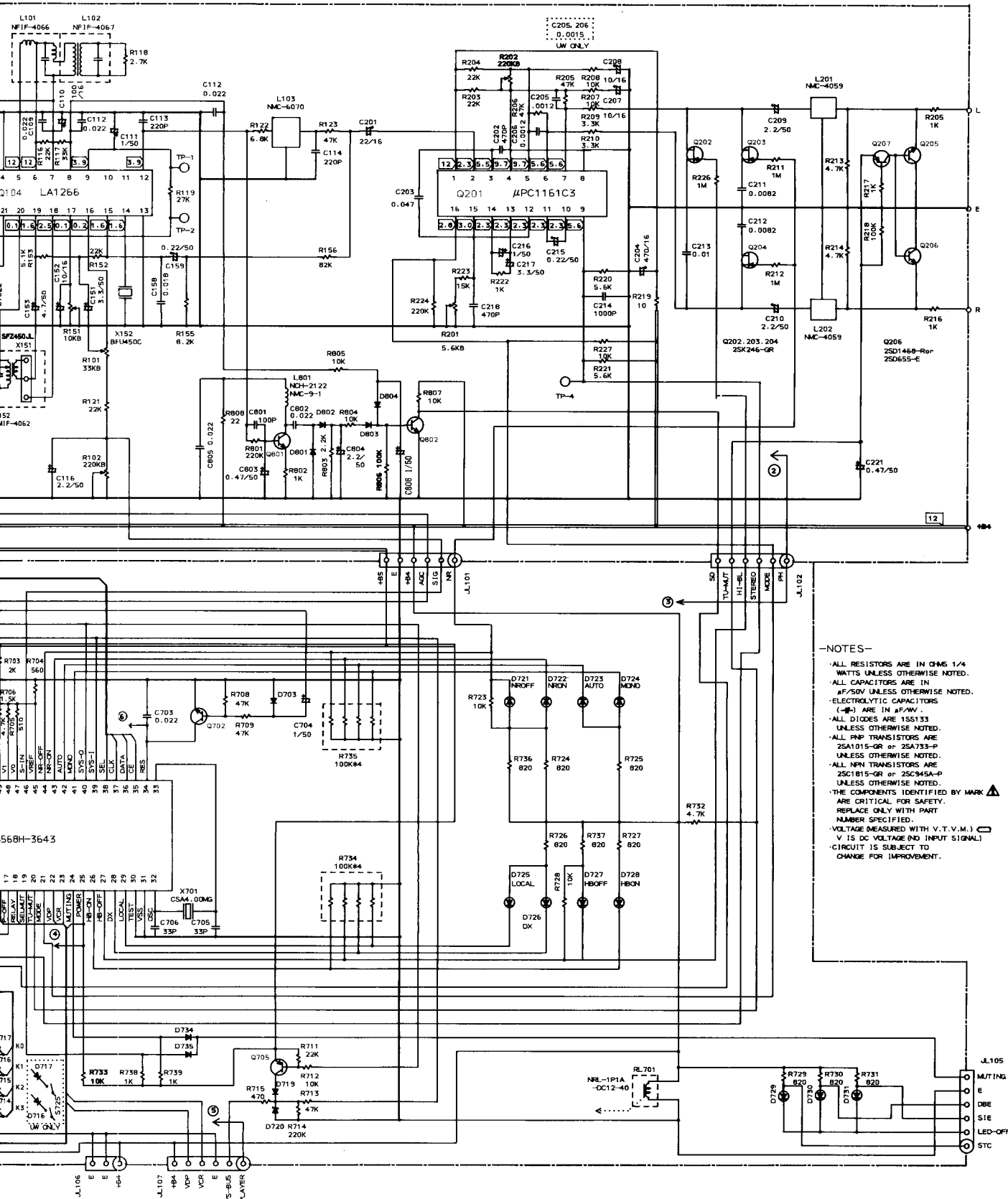

- NOTES-
- ALL RESISTORS ARE IN OHMS 1/4 WATTS UNLESS OTHERWISE NOTED.
 - ALL CAPACITORS ARE IN μF/50V UNLESS OTHERWISE NOTED.
 - ELECTROLYTIC CAPACITORS (-E) ARE IN μF/AVV.
 - ALL DIODES ARE 1S5133 UNLESS OTHERWISE NOTED.
 - ALL PNP TRANSISTORS ARE 2SA1015-GR or 2SA733-P UNLESS OTHERWISE NOTED.
 - ALL NPN TRANSISTORS ARE 2SC1815-GR or 2SC945A-P UNLESS OTHERWISE NOTED.
 - THE COMPONENTS IDENTIFIED BY MARK ARE CRITICAL FOR SAFETY. REPLACE ONLY WITH PART NUMBER SPECIFIED.
 - VOLTAGE (MEASURED WITH V.T.V.M.) V IS DC VOLTAGE (NO INPUT SIGNAL)
 - CIRCUIT IS SUBJECT TO CHANGE FOR IMPROVEMENT.

PRINTED CIRCUIT BOARD VIEW FROM BOTTOM SIDE

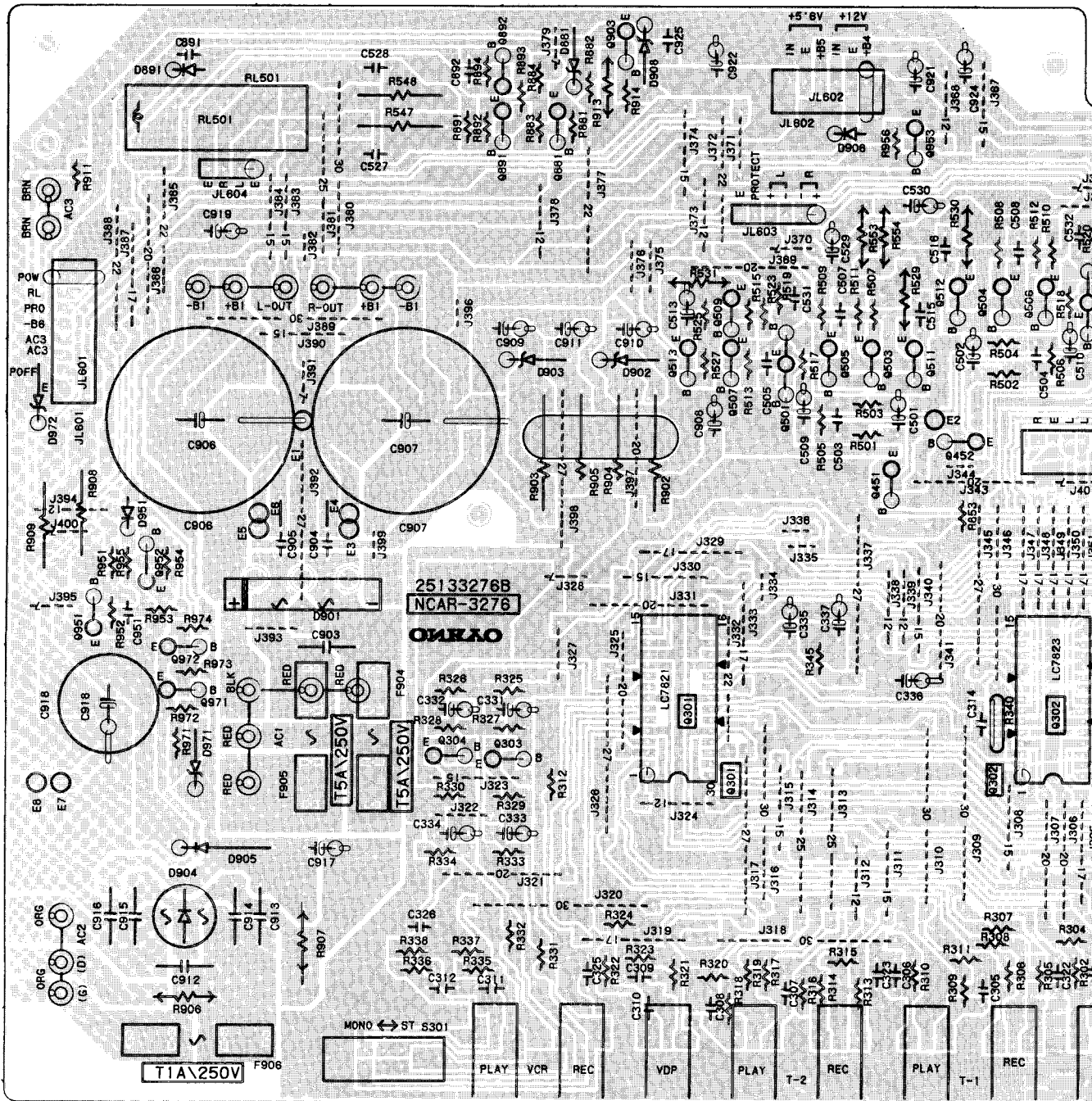

AM/FM TUNER AND SELECTOR CIRCUIT PC BOARD

DE

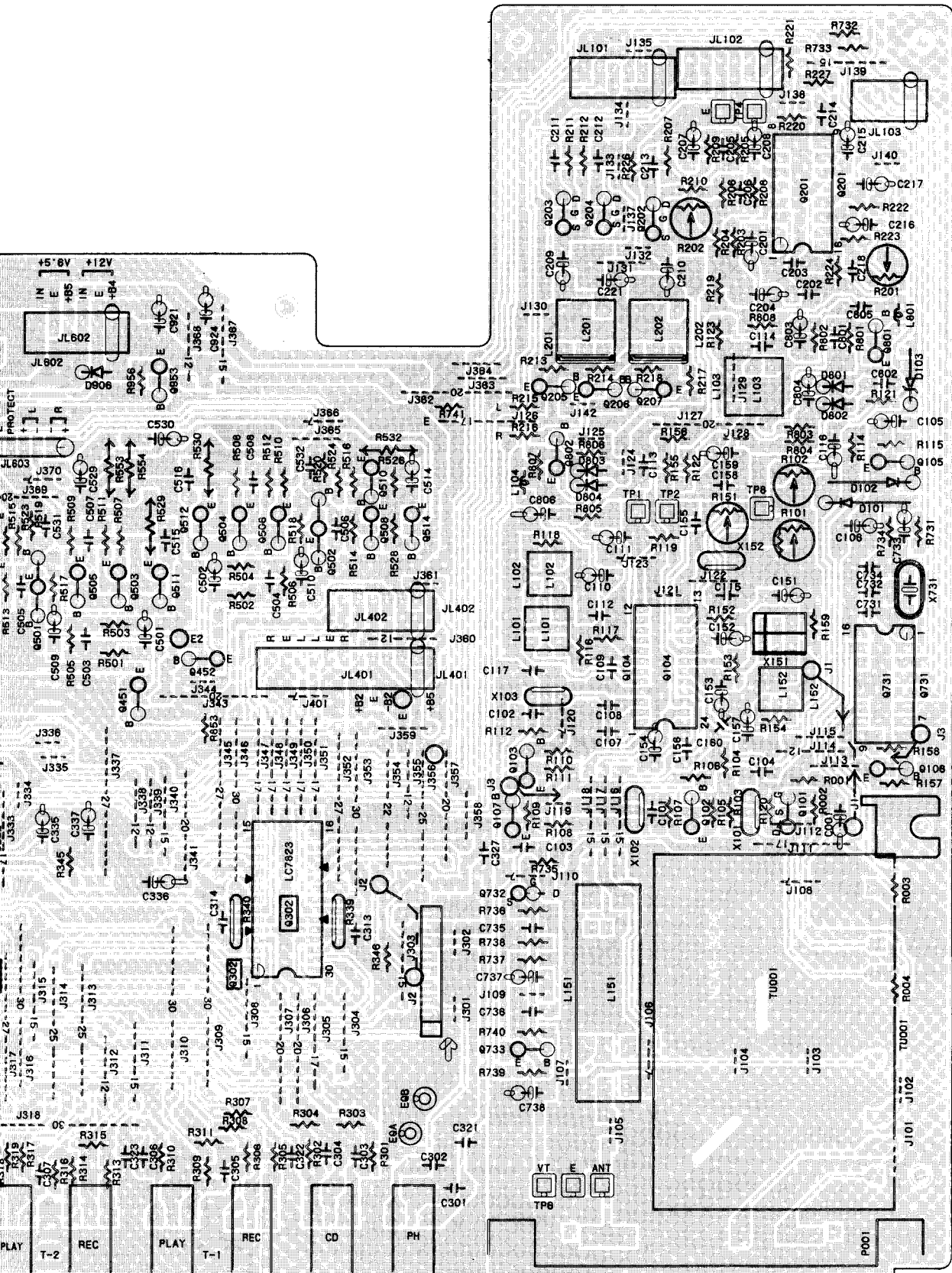

BOTTOM SIDE

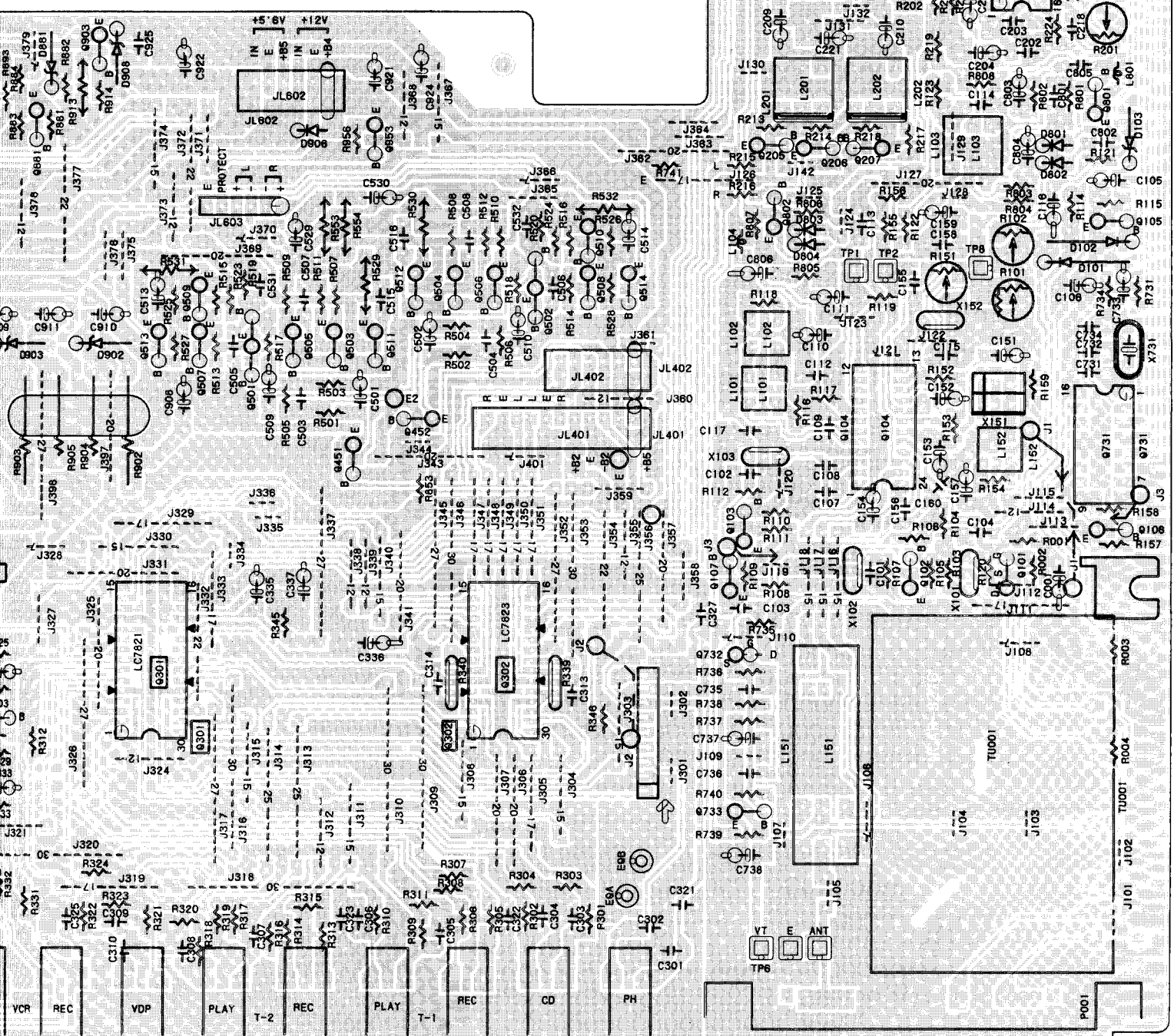

BOARD

SCHEMATIC DIAGRAM

-AMPLIFIER SECTION-

A

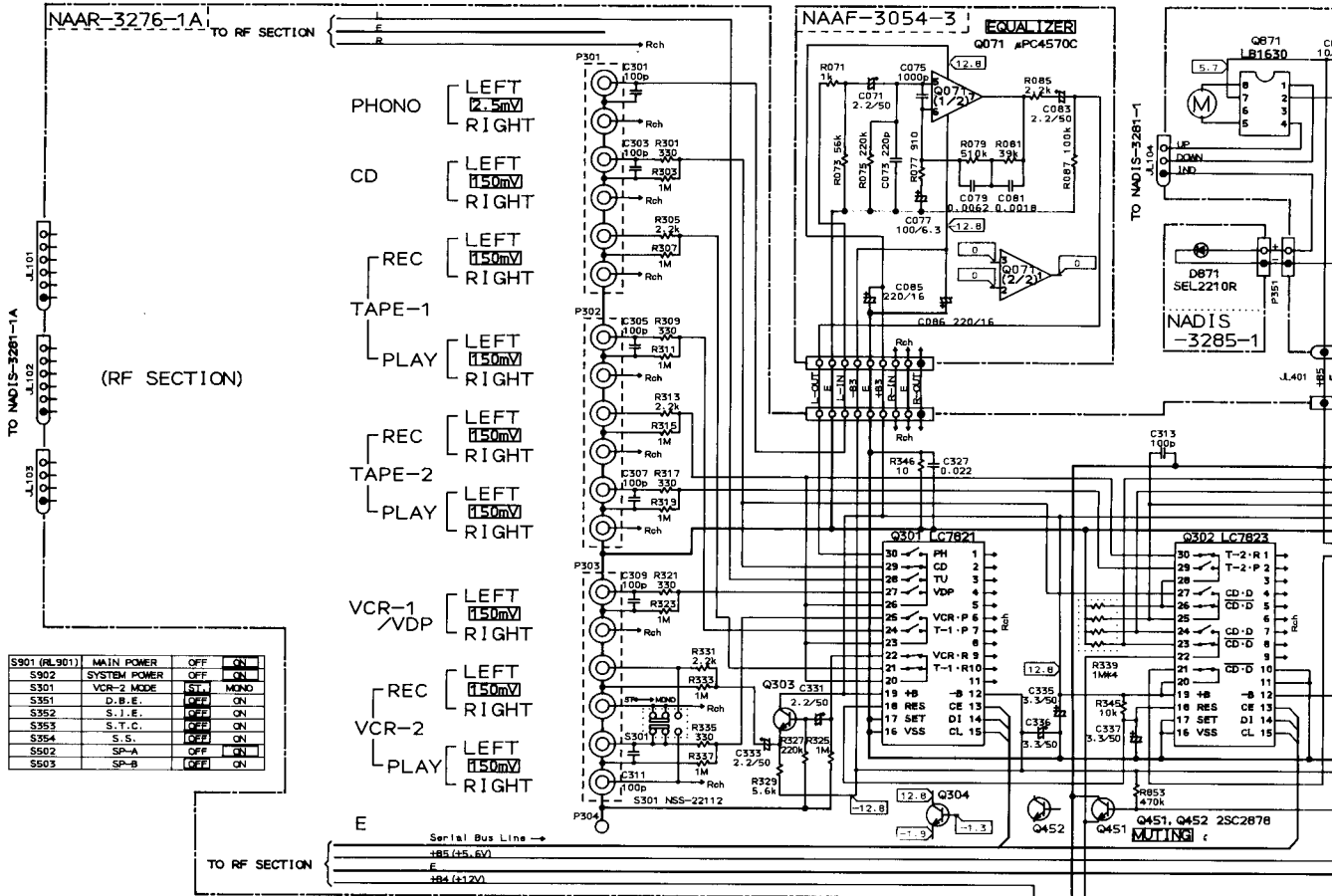

B

C

D

E

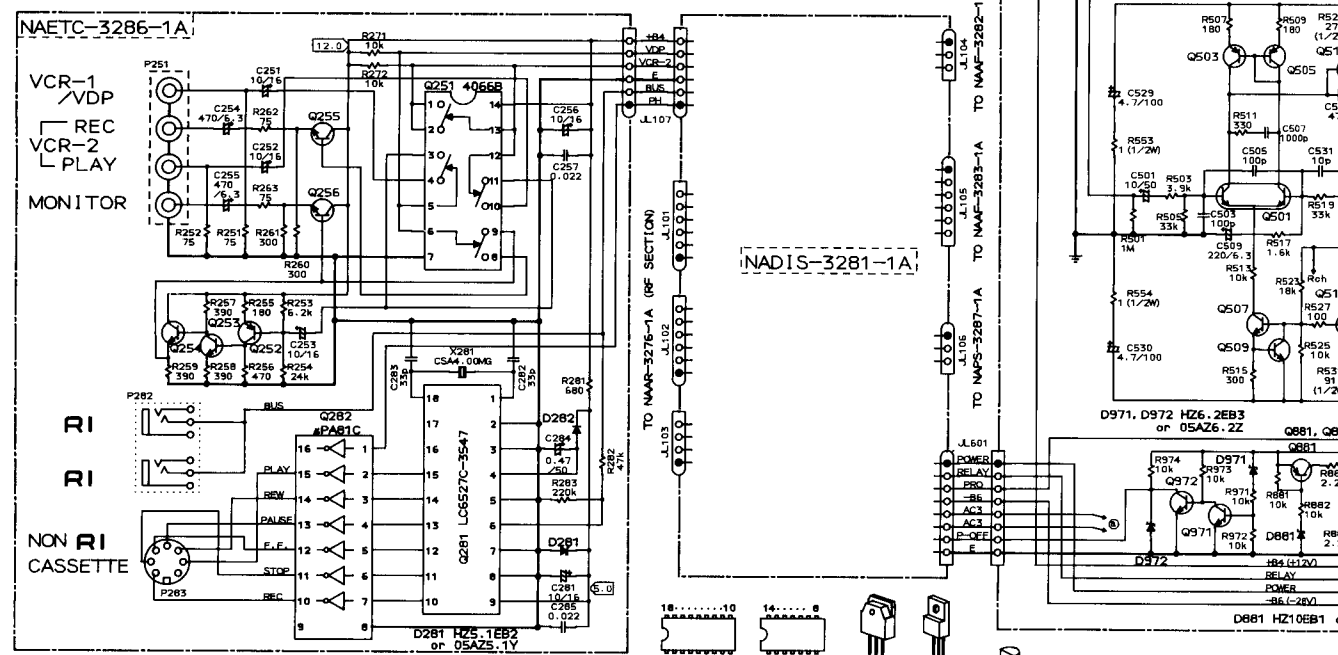

- NOTES-
- ALL RESISTORS ARE IN OHMS 1/4 WATTS UNLESS OTHERWISE NOTED
 - ALL CAPACITORS ARE IN μF/50V UNLESS OTHERWISE NOTED
 - ELECTROLYTIC CAPACITORS (E) ARE IN μF/WV
 - ALL DIODES ARE 1S5133 UNLESS OTHERWISE NOTED.
 - ALL PNP TRANSISTORS ARE 2SA1015-OR or 2SA733-P UNLESS OTHERWISE NOTED.
 - ALL NPN TRANSISTORS ARE 2SC1815-OR or 2SC945A-P UNLESS OTHERWISE NOTED.
 - THE COMPONENTS IDENTIFIED BY MARK Δ ARE CRITICAL FOR SAFETY. REPLACE ONLY WITH PART NUMBER SPECIFIED.
 - VOLTAGE (MEASURED WITH V.T.V.M.) ∇ IS DC VOLTAGE (NO INPUT SIGNAL).
 - CIRCUIT IS SUBJECT TO CHANGE FOR IMPROVEMENT.

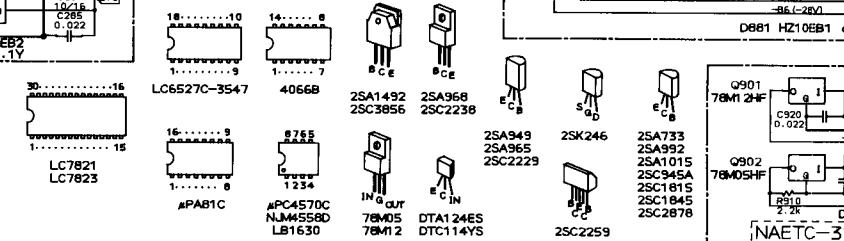

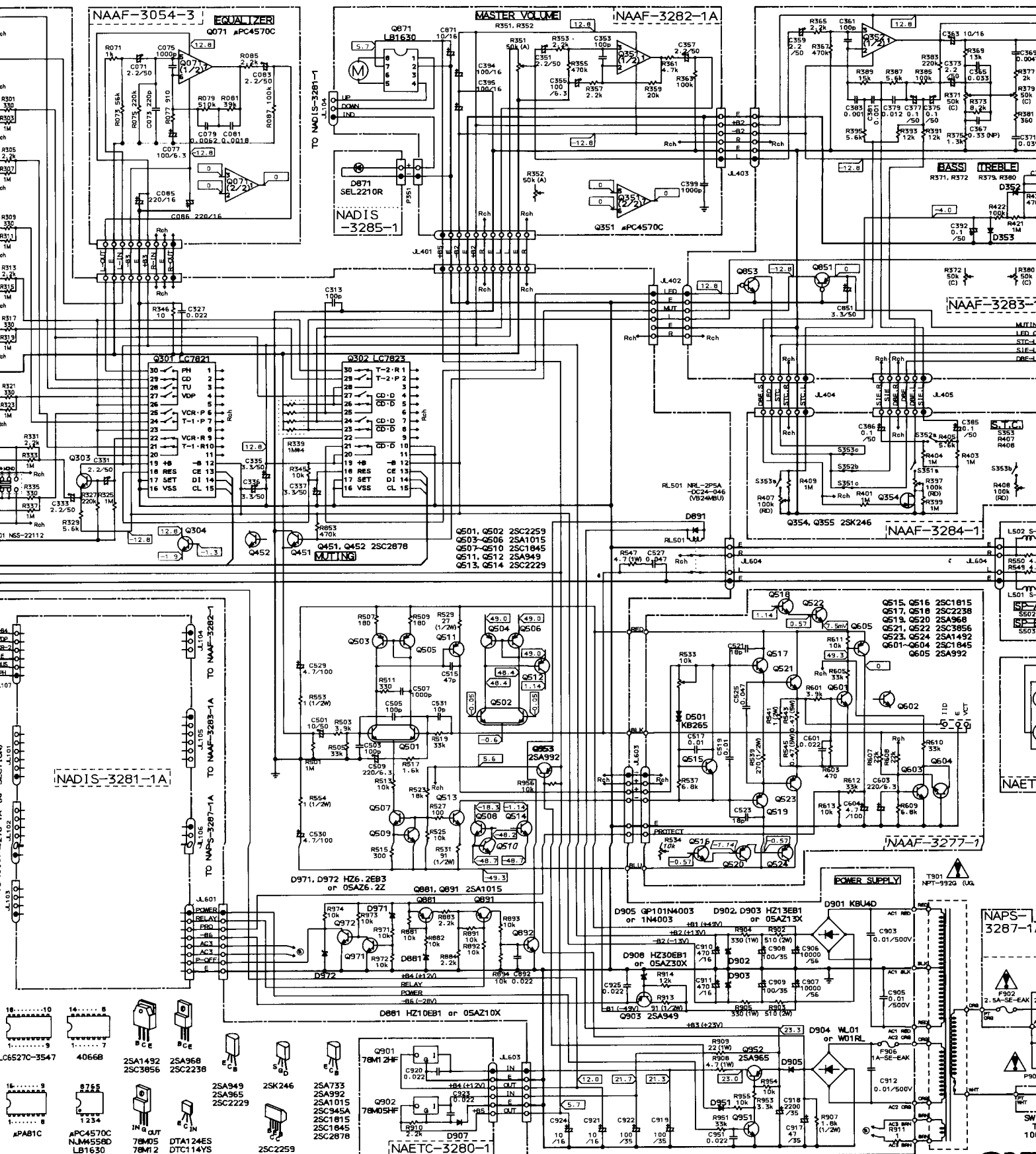

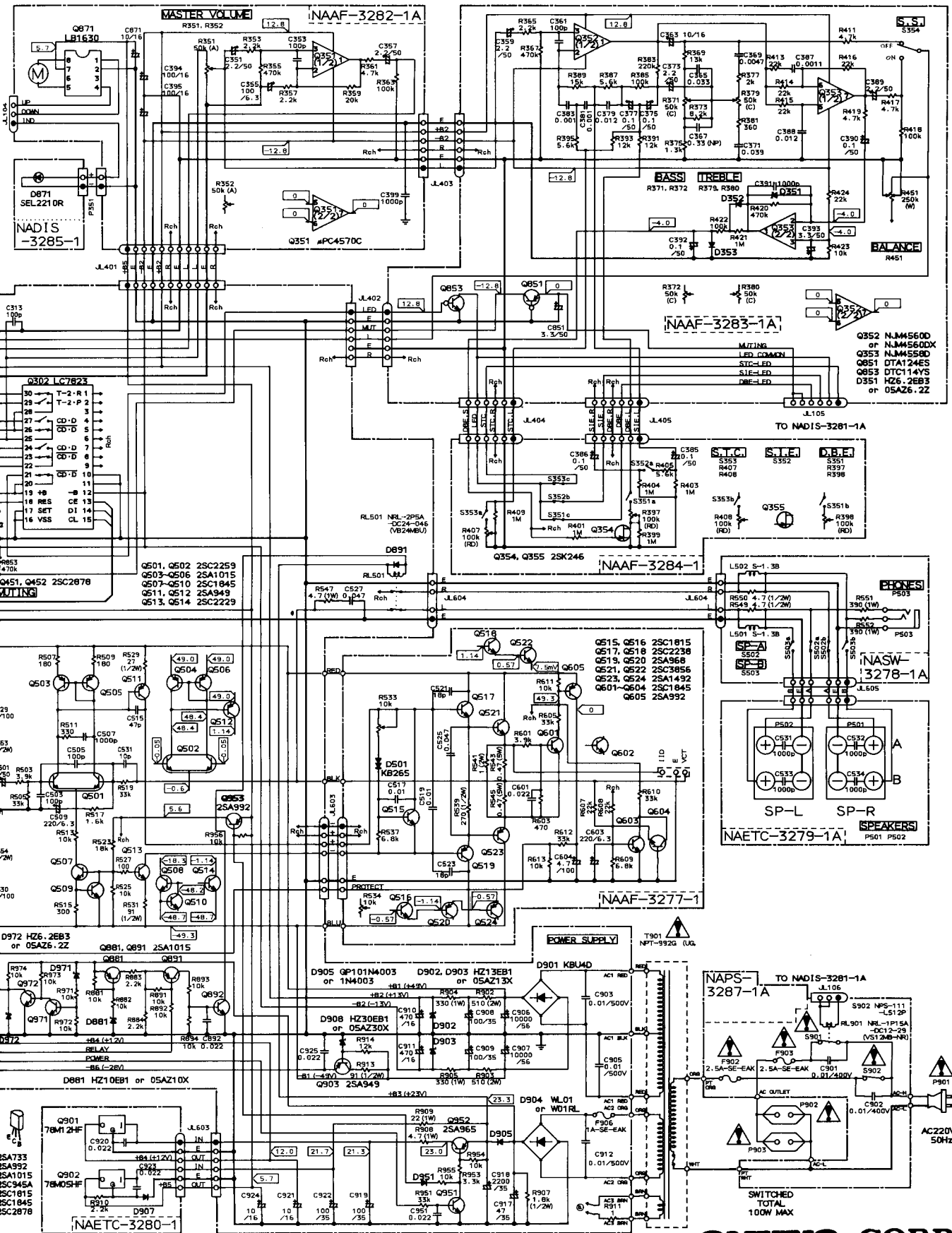

PRINTED CIRCUIT BOARD-PARTS LIST

FM/AM TUNER AND SELECTOR CIRCUIT PC BOARD(NAAR
-3276-1A)

CIRCUIT NO.	PART NO.	DESCRIPTION	CIRCUIT NO.	PART NO.	DESCRIPTION
TU001	240081	TFFG3E	L103	233383	NMC-6070
	Front end		L104	233105	NCH-1005
	ICs		L201,L202	233355A	NMC-4059
Q104	22240039	LA1266	L801	231081 or	NCH-2129 or
Q201	222678	μ PC1161C3		233031	NMC-9-1
Q301	22240079	LC7821		RF block	
Q302	22240158	LC7823	L151	232148	NMRF-7050
Q731	22240090	LM7001		Ceramic filters	
	Transistors		X101-X103	3010137	SFE10.7MMK
Q101	2212195	2SK241(GR)	X151	3010123	SFZ450JL
Q102	2211723	2SC1923(O)	X152	3010076	BFU450C
Q103	2211723	2SC1923(O)		X'tal	
Q105	2211255 or	2SC1815(GR) or	X731	3010073	XTL-7.2M
	2210746	2SC945A(P)		Capacitors	
Q106,Q207	2211455	2SA1015(GR)	C001	354741009	10 μ F,16V,Elect.
Q202-Q204	2211945	2SK246(GR)	C105	354742209	22 μ F,16V,Elect.
Q205,Q206	2211705 or	2SD655(E) or	C106	354784799	0.47 μ F,50V,Elect.
	2212794	2SD1468(R)	C110	354741019	100 μ F,16V,Elect.
Q303,Q304	2211255 or	2SC1815(GR) or	C111	354780109	1 μ F,50V,Elect.
	2210746	2SC945A(P)	C116	354780229	2.2 μ F,50V,Elect.
Q451,Q452	2212285 or	2SC2878(A) or	C151	354780339	3.3 μ F,50V,Elect.
	2212286	2SC2878(B)	C152	354741009	10 μ F,16V,Elect.
Q501,Q502	2211371 or	2SC2259(O-001) or	C153	354780479	4.7 μ F,50V,Elect.
	2211372	2SC2259(O-002)	C154,C157	354741009	10 μ F,16V,Elect.
Q503-Q506	2211455	2SA1015(GR)	C159	354782299	0.22 μ F,50V,Elect.
Q507-Q510	2211732 or	2SC1845(F) or	C201	354742209	22 μ F,16V,Elect.
	2211733	2SC1845(E)	C204	354744719	470 μ F,16V,Elect.
Q511,Q512	2211353 or	2SA949(O) or	C207,C208	354741009	10 μ F,16V,Elect.
	2211354	2SA949(Y)	C209,C210	354780229	2.2 μ F,50V,Elect.
Q513,Q514	2211633 or	2SC2229(O) or	C215	354782299	0.22 μ F,50V,Elect.
	2211634	2SC2229(Y)	C216	354780109	1 μ F,50V,Elect.
Q732	2212294	2SK108(D)	C217	354780339	3.3 μ F,50V,Elect.
Q733,Q801	2211255 or	2SC1815(GR) or	C218	370134714	470pF \pm 5%,100V,APS
Q802,Q892	2210746	2SC945A(P)	C221	354784799	0.47 μ F,50V,Elect.
Q881,Q891	2211455	2SA1015(GR)	C331-C334	354780229	2.2 μ F,50V,Elect.
Q903	2211353 or	2SA949(O) or	C335-C337	354780339	3.3 μ F,50V,Elect.
	2211354	2SA949(Y)	C501,C502	354781009	10 μ F,50V,Elect.
Q951,Q971	2211255 or	2SC1815(GR) or	C509,C510	354722219	220 μ F, 6.3V,Elect.
Q972	2210746	2SC945A(P)	C529,C530	354790479	4.7 μ F, 100V,Elect.
Q952	2211643 or	2SA965(O) or	C733	354721019	100 μ F, 6.3V,Elect.
	2211644	2SA965(Y)	C737	354780479	4.7 μ F,50V,Elect.
Q953	2211792 or	2SA992(F) or	C738	354782299	0.22 μ F,50V,Elect.
	2211793	2SA992(E)	C803	354784799	0.47 μ F,50V,Elect.
	Diodes		C804	354780229	2.2 μ F,50V,Elect.
D101,D102	223132	1K60	C806	354780109	1 μ F,50V,Elect.
D801-D804	223163	1SS133	C903,C905	335251039A	0.01 μ F,500V,Ceramic
D881	224651001 or	HZ10EB1 or	C906,C907	3504224	10000 μ F,56V,Elect.
	224151001	05AZ10X	C908,C909	354761019	100 μ F,35V,Elect.
D891	223163	1SS133	C910,C911	354744719	470 μ F,16V,Elect.
D901	22380024	KBU4D	C912	335251039A	0.01 μ F,500V,Ceramic
D902,D903	224151301 or	05ZA13X or	C917	354764709	47 μ F,35V,Elect.
	224651301	HZ13EB1	C918	354762229	2200 μ F,35V,Elect.
D904	223862 or	WL01 or	C919	354761019	100 μ F,35V,Elect.
	223890	W01RL	C921,C924	354741009	10 μ F,16V,Elect.
D905	223880 or	GP101N4003 or	C922	354761019	100 μ F,35V,Elect.
	223896	1N4003F	Resistors		
D908	224153001 or	05AZ30X or	R101	5210067	N06HR33KBD,Semi-fixed
	224653001	HZ30EB1	R102	5210072	N06HR220KBD,Semi-fixed
D951	223163	1SS133	R151	5210064	N06HR10KBD,Semi-fixed
D971,D972	224650623 or	HZ6.2EB3 or	R201	5210062	N06HR4.7KBD,Semi-fixed
	224150623	05AZ6.2Z	R202	5210072	N06HR220KBD,Semi-fixed
	Transformers		R339,R340	49163105404	1Mohm \times 4,1/10W,Network
L101	233389	NFIF-4066	R529,R530	442522704	27ohm,1/2W,Metal oxide film
L102	233390	NFIF-4067	R531,R532	442529104	91ohm,1/2W,Metal oxide film
L152	232139	NMIF-4062			

PRINTED CIRCUIT BOARD VIEW FROM BOTTOM SIDE

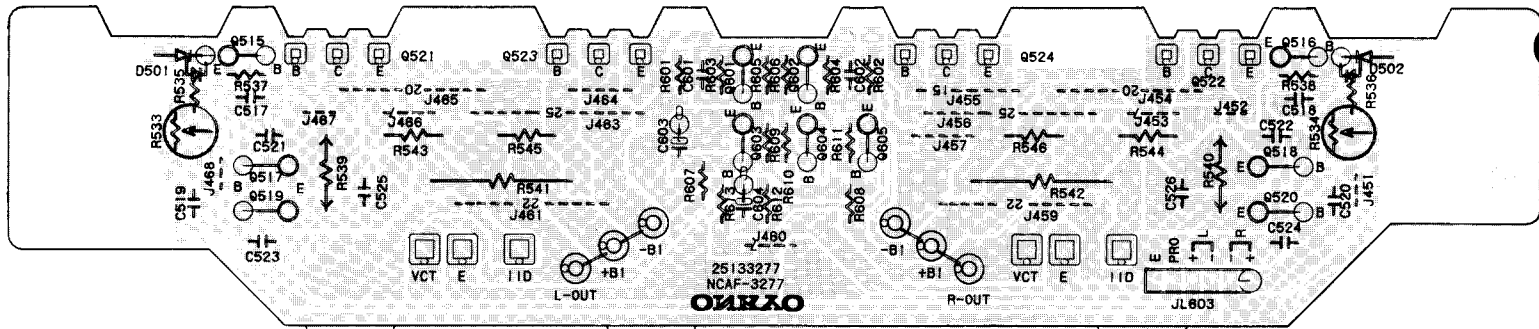

POWER AMPLIFIER PC BOARD

CIRCUIT NO.	PART NO.	DESCRIPTION
R547,R548	441620474	4.7ohm,1W,Metal oxide film
R553,R554	442520104	1ohm,1/2W,Metal oxide film
R902,R903	441725114	510ohm,2W,Metal oxide film
R904,R905	441623314	330ohm,1W,Metal oxide film
R906	442524794	0.47ohm, 1/2W,Metal oxide film
R907	442521824	1.8kohm,1/2W,Metal oxide film
R908	441620474	4.7ohm,1W,Metal oxide film
R909	441622204	22ohm,1W,Metal oxide film
R913	442529104	91ohm, 1/2W,Metal oxide film
RL501	250653339	NRL-2P5A-DC24-046
Terminals		
P001	25060087	NTM-2PDMN31,Antenna
P301-P303	25045213	NPJ-6PDBL-92
Switch		
S301	25065286	NPS-22112,VCR mode
Sockets		
P101,P102	25050270	NSCT-6P98
P402,P602	25050270	NSCT-6P98
P103	25050268	NSCT-4P96
P401	25050275	NSCT-11P103
P601	25050272	NSCT-8P100
Fuse		
F906	252070	1A-SE-EAK,Secondary
Fuseholders		
F906a	25050065	YSH403T
Radiator		
	27160166	

POWER AMPLIFIER PC BOARD(NAAF-3277-1)

CIRCUIT NO.	PART NO.	DESCRIPTION
Q515,Q516	2211255	2SC1815(GR)
Q517,Q518	2200863 or 2200864	2SC2238(O) or 2SC2238(Y)
Q519,Q520	2200873 or 2200874	2SA968(O) or 2SA968(Y)
Q521,Q522 ☆	2201653, 2201654 or 2201655	2SC3856(O), 2SC3856(Y) or 2SC3856(P)
Q523,Q524 ☆	2201663, 2201664 or 2201665	2SA1492(O), 2SA1492(Y) or 2SA1492(P)

CAUTION: Replacement for transistor of mark ☆,if necessary, must be made from the same beta group (H_{FE}), as the original type.

Ex. 2SC3856(O) 2SA1492(O)

Same beta group

Q601-Q604	2211732 or 2211733	2SC1845(F) or 2SC1845(E)
Q605	2211792 or 2211793	2SA992(F) or 2SA992(E)

Diodes

D501,D502	4000120	KB265
-----------	---------	-------

Capacitors

C603	354722219	220 μF, 6.3V,Elect.
C604	354790479	4.7 μF, 100V,Elect.

Resistors

R533,R534	5210064	N06HR10KBD,Semi-fixed
R539,R540	442522714	270ohm,1/2W,Metal oxide film
R541,R542	441720104	1ohm,2W,Metal oxide film
R543-R546	4000080 or 4500022	0.47ohm,5W,Metal plate

Terminals

25060118	NTM-1S52,For leg of power transistor
----------	--------------------------------------

PRINTED CIRCUIT BOARD VIEW FROM BOTTOM SIDE

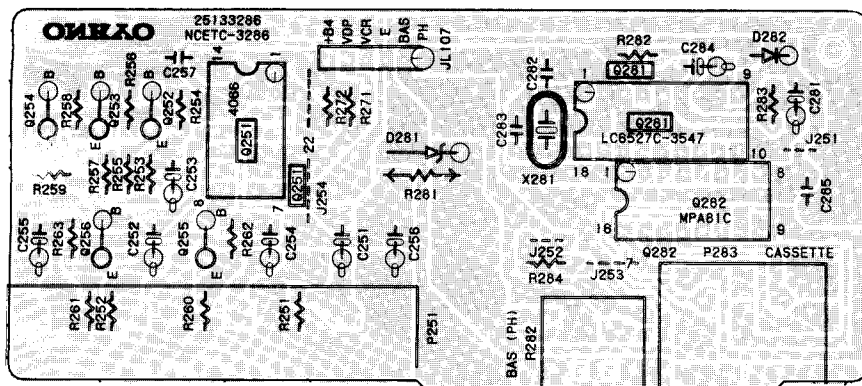

VIDEO TERMINAL PC BOARD

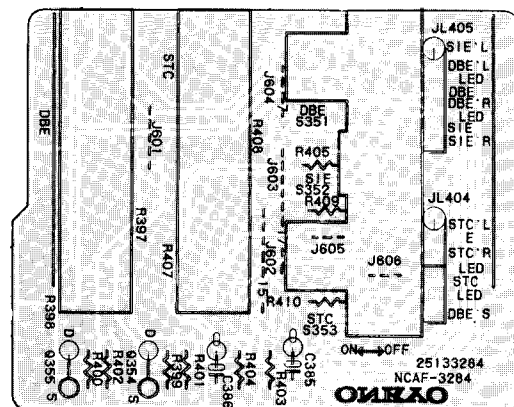

SWITCH PC BOARD

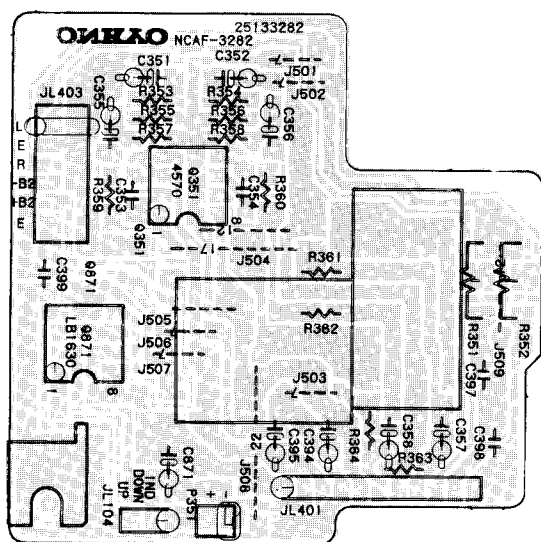

VOLUME PC BOARD

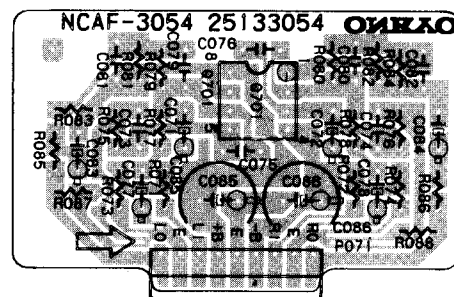

EQUALIZER AMPLIFIER PC BOARD



VOLUME INDICATOR PC BOARD

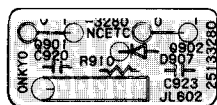

CONST. VOLTAGE CIRCUIT PC BOARD

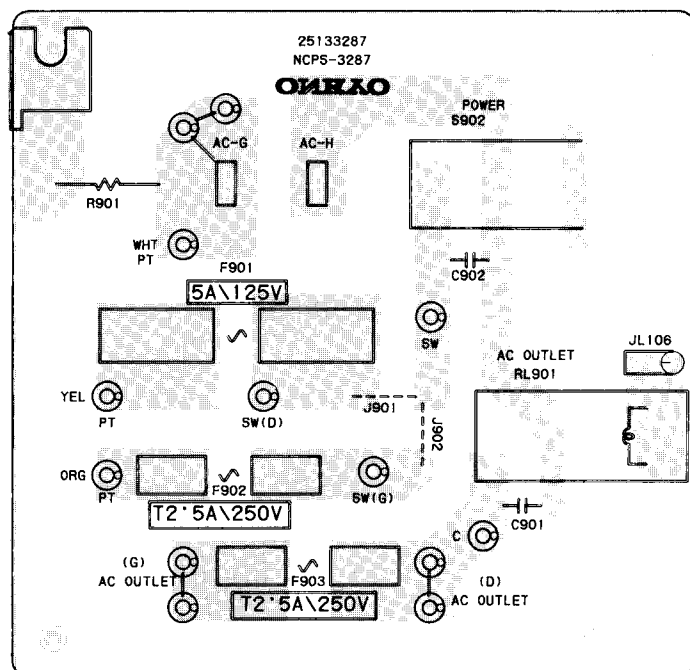

POWER SUPPLY CIRCUIT PC BOARD

PRINTED CIRCUIT BOARD-PARTS LIST

VIDEO TERMINAL PC BOARD(NAETC-3286-1A)

CIRCUIT NO.	PART NO.	DESCRIPTION
Q251	222840661	4066B
Q281	22240145	LC6527C-3547
Q282	222807	μ PA81C
Transistors		
Q252	2211455 or 2210803	2SA1015(GR) or 2SA733(P)
Q253-Q256	2211255 or 2210746	2SC1815(GR) or 2SC945A(P)
Diodes		
D281	224650512	HZ5.1EB2 or
	224150512	05AZ5.1Y
D282	223163	1SS133
Osc. element		
X281	3010099	CSA4.00MG,Ceramic
Capacitors		
C251-C253	354741009	10 μ F,16V,Elect.
C254,C255	354724719	470 μ F,6.3V,Elect.
C256,C281	354741009	10 μ F,16V,Elect.
C284	354784799	0.47 μ F,50V,Elect.
Terminals		
P251	25045216	NPJ-4PDBL94
P282	25045172	HSJ1003-01-020
Socket		
P283	25050294	NSCT-8P121

VOLUME PC BOARD(NAAF-3282-1A)

CIRCUIT NO.	PART NO.	DESCRIPTION
Q351	22240050	μ PC4570C,IC
Q871	222963	LB1630,IC
C351,C352	354780229	2.2 μ F,50V,Elect. capacitors
C355,C356	354721019	100 μ F,6.3V, Elect. capacitors
C357,C358	354780229	2.2 μ F,50V,Elect. capacitors
C394,C395	354741019	100 μ F,16V,Elect. capacitors
C871	354741009	10 μ F,16V,Elect. capacitor
R351,R352	5104234	N16RGM50KA30F,Variable resistor,Volume
P351	2000635A	NSAS-4P591,Socket
	25050270	NSCT-6P98,Socket

VOLUME INDICATOR PC BOARD(NADIS-3285-1)

CIRCUIT NO.	PART NO.	DESCRIPTION
D871	225241 or 225242 27190545	SEL2210R-C or SEL2210R-D,LED Holder,LED

CONST. VOLTAGE CIRCUIT PC BOARD(NAETC-3280-1)

CIRCUIT NO.	PART NO.	DESCRIPTION
Q901	222780125NEC	78M12HF,IC
Q902	222780055NEC	78M05HF,IC
D907	223163	1SS133,Diode

SWITCH PC BOARD(NAAF-3284-1)

CIRCUIT NO.	PART NO.	DESCRIPTION
Transistors		
Q354,Q355	2211945	2SK246(GR)
Capacitors		
C385,C386	354781099	0.1 μ F,50V,Elect.
Resistors		
R397,R398	6182003	N25LGL100KRD10Z,Variable,D.B.E
R407,R408	6182003	N25LGL100KRD10Z,Variable,S.T.C
Switches		
S351-S353	25035589	NPS-122-242-L551

EQUALIZER AMPLIFIER PC BOARD(NAAF-3054-3)

CIRCUIT NO.	PART NO.	DESCRIPTION
IC		
Q071	22240191 or 222570	NJM4565DD or NJM4560DX
Elect. capacitors		
C071,C072	354780229	2.2 μ F,50V
C077,C078	354721019	100 μ F,6.3V
C083,C084	354780229	2.2 μ F,50V
C085,C086	354742219	220 μ F,16V
Plug		
P071	25055334	NPLG-9P317

POWER SUPPLY CIRCUIT PC BOARD(NAPS-3287-1A)

CIRCUIT NO.	PART NO.	DESCRIPTION
C901,C902	3500065A	Δ DE7150FZ103PAC400V/125V, Capacitor IS
S902	25035550	Δ NPS-111-L512P,Power
RL901	25065248	Δ NRL-1P15A-DC12-29,Relay
F902a	25050065	Δ YSH-403T,Fuseholders
F902	252075	Δ 2.5A-SE-EAK,Primary fuse
F903a	25050065	Δ YSH-403T,Fuseholders
F903	252075	Δ 2.5A-SE-EAK,Fuse for AC outlet

NOTE:THE COMPONENTS IDENTIFIED BY MARK Δ ARE CRITICAL FOR RISK OF FIRE AND ELECTRIC SHOCK. REPLACE ONLY WITH PART NUMBERS SPECIFIED.

BLOCK DIAGRAM

TUNER SECTION

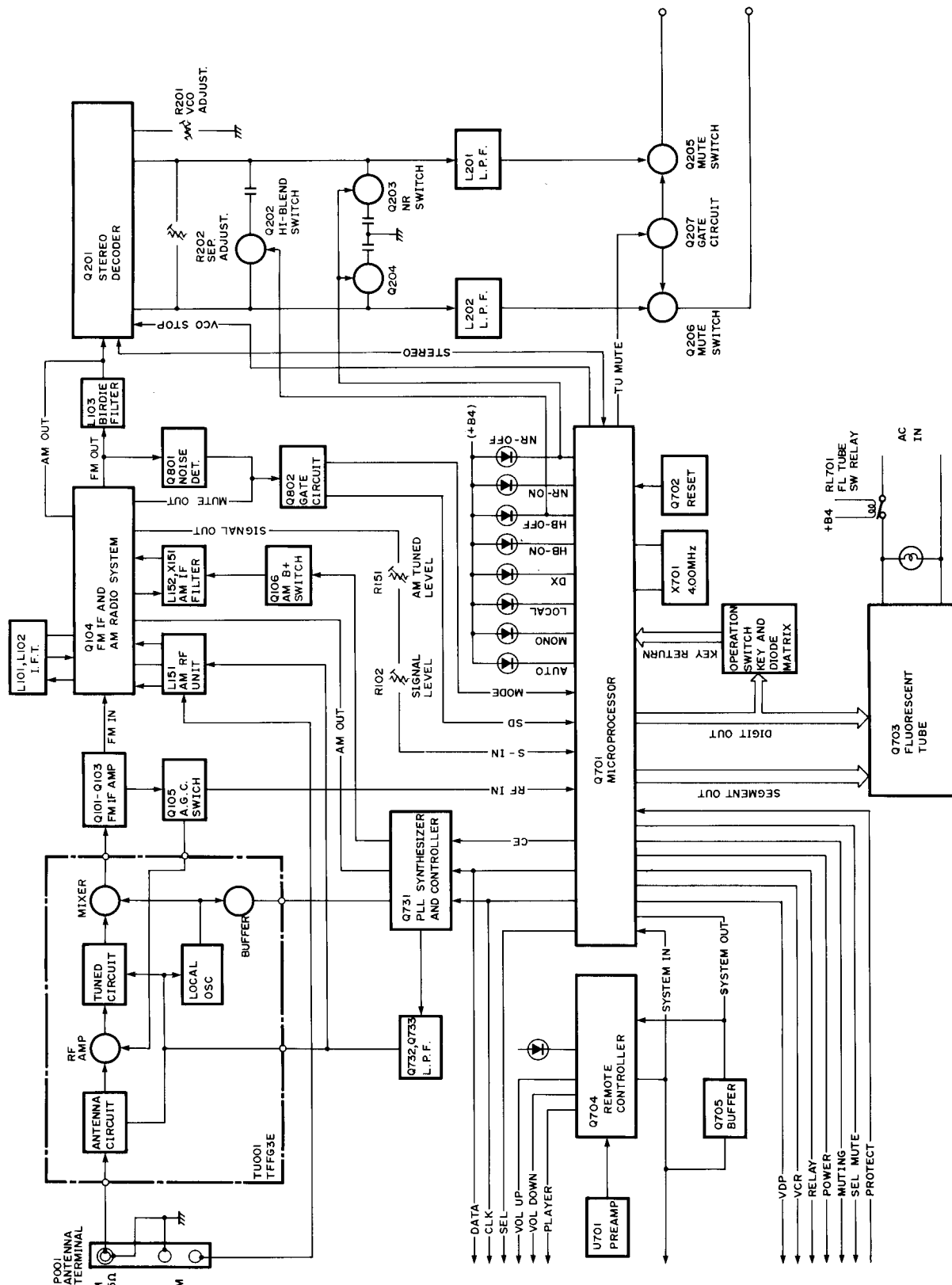

AMPLIFIER SECTION

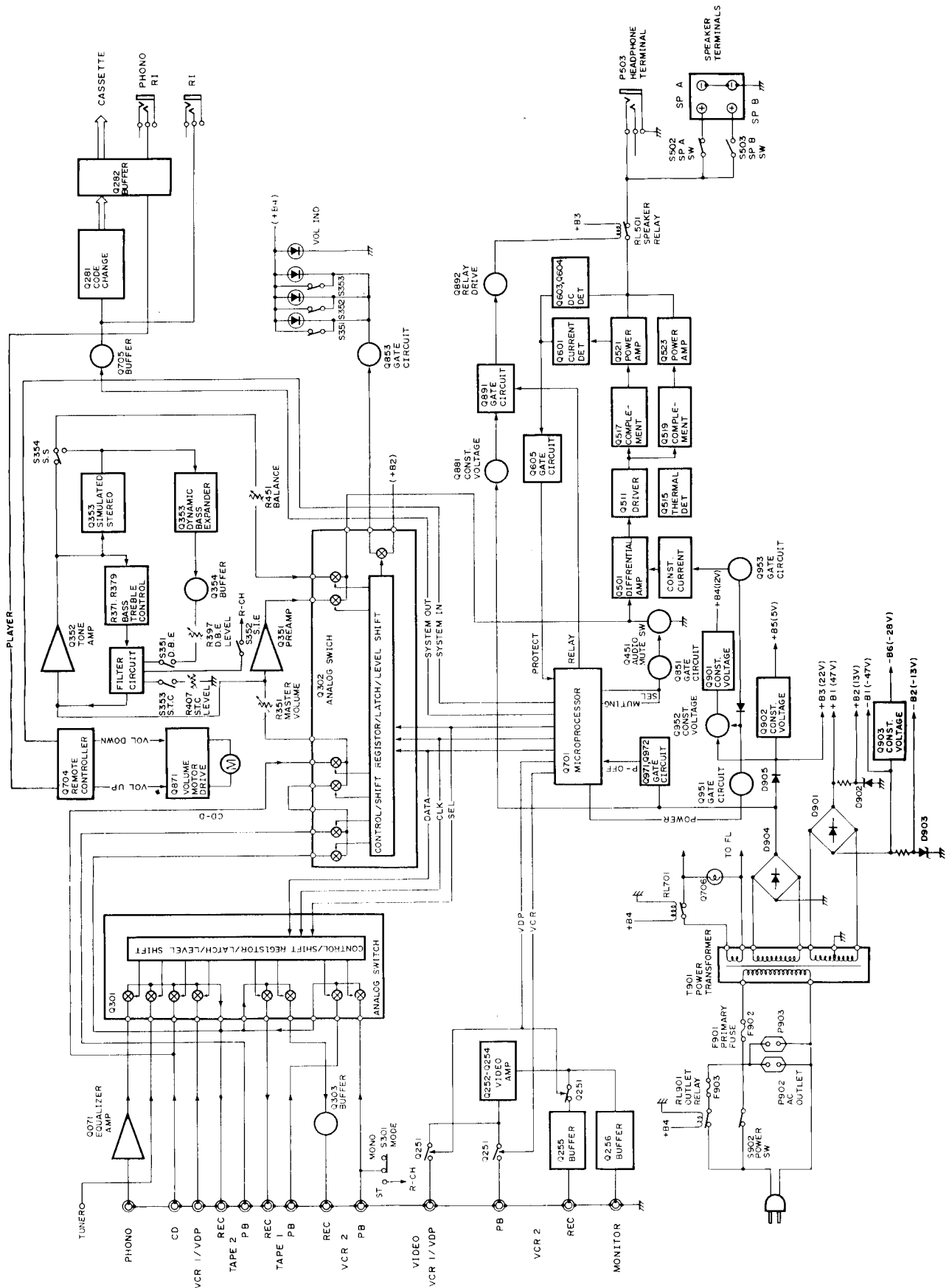

DISASSEMBLING PROCEDURES

1. Top cover

Remove a screw (3TTS+8BQ(BC)) holding the top cover and the back panel.
Remove the four screws (3TTS+8B(BC)) holding the back panel and the chassis.

2. Front panel

Remove the top cover.
Remove the six screws (3TTP+8P(BC)) holding the front panel and the front basket.

3. Power amplifier pc board

Remove the top cover.
Remove the five screws A.
Cut the binder B.

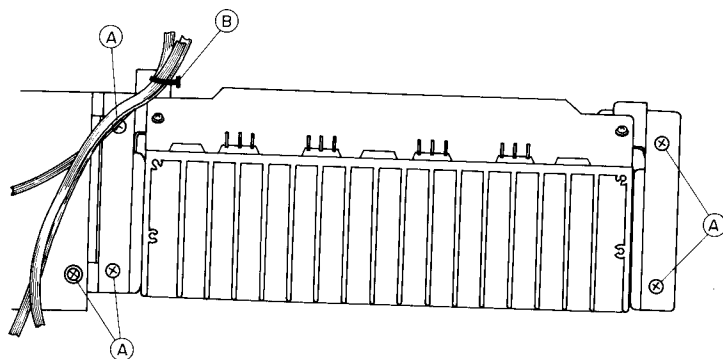

4. FM/AM tuner and selector switch pc board

Remove the top cover.
Remove the three screws C holding the pc board and chassis.
Remove the five screws D holding the back panel and chassis.
Remove the pc board from the two holders.

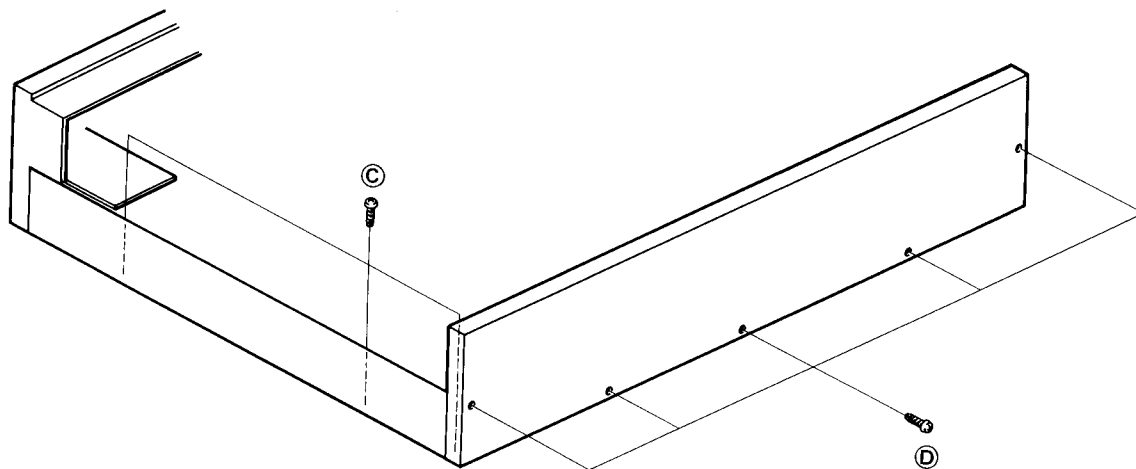

PACKING VIEW

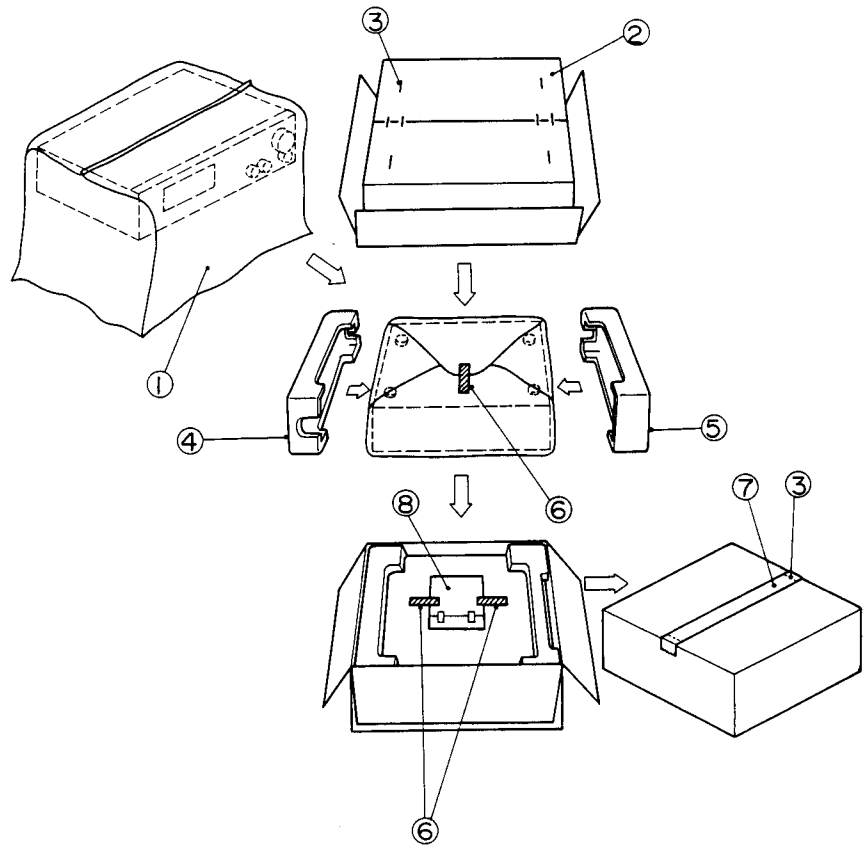

REF. NO.	PART NO.	DESCRIPTION
1	29100034	850×650mm, Poly-vinyl bag
	29095012-1	800×500mm, Protection sheet (Black model)
2	29051689	Master carton box (Black model)
	29051686	Master carton box (Silver model)
3	282301	Sealing hook
4	29091263	Pad R
5	29091262	Pad L
6	29110032	Adhesive tape
7	260012	Damplon tape
8	Accessory bag ass'y	
	29341253	Instruction manual
	292092	FM antenna
	232140	NMA-3057, AM loop antenna
	2010169	Connection cord for RI
	3010054	UM-3, Two batteries
	24140025	RC-119S, Remote control transmitter
	29100097	250×350mm, Poly-vinyl bag
	29365020	Warranty card
	29100094A	Poly-vinyl bag for warranty card

ONKYO CORPORATION

International Division: No. 24 Mori Bldg., 23-5, 3-chome, Nishi-Shinbashi, Minato-ku, Tokyo, Japan
 Telex: 2423551 ONKYO J. Phone: 03-432-6981

ONKYO DEUTSCHLAND GMBH, ELECTRONICS

8034 München-Germering, Industriestrasse 18 West Germany. Fax: 49-89-849-3226 Telefon: (089)-84-3071

AS102