

ONKYO® SERVICE MANUAL

QUARTZ SYNTHESIZED TUNER AMPLIFIER MODEL TX-8211



Black and Silver models

BMD/BMDN	120V AC, 60Hz
BMP/SMP/BMPA	230V AC, 50Hz
BMWT	230V AC, 50Hz
BMPT	120V/220-230V AC, 50/60Hz

SAFETY-RELATED COMPONENT WARNING!!

COMPONENTS IDENTIFIED BY MARK Δ ON THE SCHEMATIC DIAGRAM AND IN THE PARTS LIST ARE CRITICAL FOR RISK OF FIRE AND ELECTRIC SHOCK. REPLACE THESE COMPONENTS WITH ONKYO PARTS WHOSE PARTS NUMBERS APPEAR AS SHOWN IN THIS MANUAL.

MAKE LEAKAGE-CURRENT OR RESISTANCE MEASUREMENTS TO DETERMINE THAT EXPOSED PARTS ARE ACCEPTABLY INSULATED FROM THE SUPPLY CIRCUIT BEFORE RETURNING THE APPLIANCE TO THE CUSTOMER.

TABLE OF CONTENTS

SPECIFICATIONS	2
SERVICE PROCEDURES	3
EXPLODED VIEW	4
PARTS LIST	5
BLOCK DIAGRAMS	6
MICROPROCESSOR CONNECTION DIAGRAM	8
MICROPROCESSOR TERMINAL DESCRIPTION.....	9
IC BLOCK DIAGRAMS AND DESCRIPTION	10
PACKING VIEW /PARTS LIST.....	13
ADJUSTMENT PROCEDURES	14
PRINTED CIRCUIT BOARD VIEW FROM BOTTOM SIDE	17
PRINTED CIRCUIT BOARD-PARTS LIST	22
SCHEMATIC DIAGRAMS	25
FL TUBE	29



SPECIFICATIONS

TX-8211

AMPLIFIER SECTION

Power Output:

USA & Canadian models: 50 watts per channel, min RMS, at 8 ohms, both channels driven from 20 Hz to 20 kHz, with no more than 0.08% THD.

European models: 2 × 70 watts at 4 ohms, 1 kHz (DIN)

Asian models: 2 × 90 watts at 4 ohms, 1 kHz (EIAJ)

Dynamic power output:

USA & Canadian models: 2 × 135 watts at 2 ohms

2 × 105 watts at 4 ohms

2 × 70 watts at 8 ohms

Other area models: 2 × 110 watts at 2 ohms

2 × 90 watts at 4 ohms

2 × 55 watts at 8 ohms

Total Harmonic Distortion: 0.08% at rated power
0.08% at 1 watt output

IM Distortion: 0.08% at rated power
0.08% at 1 watt output

Damping Factor: 60 at 8 ohms

Input Sensitivities and Impedance:

PHONO: 2.5 mV, 50 kohms

Line (CD, TAPE-1, 2): 150 mV, 50 kohms

Output Level and Impedance:

Rec out (TAPE-1, 2): 150 mV, 2.2 kohms

Phono Overload: 120 mV RMS, at 1,000 Hz, 0.5% THD.

Frequency Response: 20 to 30,000 Hz, ±1 dB

RIAA Deviation: 20 to 20,000 Hz, ±0.8 dB

Tone Control:

BASS: ±10 dB at 100 Hz

TREBLE: ±10 dB at 10,000 Hz

Signal-to-Noise Ratio:

PHONO: 80 dB (IHF A, 5 mV input)

CD/TAPE: 100 dB (IHF A)

Muting: -50 dB

TUNER SECTION

FM:

Tuning Range:

U.S. and Canadian models: 87.50 to 108.00 MHz (100 kHz steps)

European and worldwide models:

87.50 to 108.00 MHz (50 kHz steps)

Usable Sensitivity: Mono: 11.2 dBf, 1.0 μV (75 ohms IHF)
0.9 μV (75 ohms DIN)

Stereo: 17.2 dBf, 2.0 μV (75 ohms IHF)
23 μV (75 ohm DIN)

50dB Quieting Sensitivity: Mono: 17.2 dBf, 2.0 μV (75 ohms)
Stereo: 37.2 dBf, 20.0 μV (75 ohms)

Capture Ratio: 1.5 dB

Image Rejection Ratio:

U.S. and Canadian models: 40 dB

Other models: 85 dB

IF Rejection Ratio: 90 dB

Signal-to-Noise Ratio: Mono: 76 dB, IHF

Stereo: 70 dB, IHF

Alternate Channel Attenuation (±400 kHz):

Mono 55 dB, IHF

Selectivity: 55 dB DIN (±300 kHz 40 kHz Devi.)

AM Suppression Ratio: 50 dB

Total Harmonic Distortion: Mono: 0.15%

Stereo: 0.25%

Frequency Response: 30 to 15,000 Hz ±1.5 dB

Stereo Separation: 45 dB at 1,000 Hz/

30 dB at 100 to 10,000 Hz

Stereo Threshold: 17.2 dBf, 2.0 μV (75 ohms)

AM:

Tuning Range:

U.S. and Canadian models: 530 to 1,710 kHz (10 kHz steps)

European models: 522 to 1,611 kHz (9 kHz steps)

Worldwide models: 530 to 1,710 kHz (10 kHz steps)

531 to 1,602 kHz (9 kHz steps)

Usable Sensitivity: 30 μV

Image Rejection Ratio: 40 dB

IF Rejection Ratio: 40 dB

Signal-to-Noise Ratio: 40 dB

Total Harmonic Distortion: 0.7%

GENERAL

Power Supply:

U.S. and Canadian models AC120 V, 60 Hz

European and Australian models:

AC230 V, 50 Hz

Worldwide models: AC 220-230/120 V switchable, 50/60 Hz

Power Consumption: 180 W

Dimensions (W × H × D): 435 × 150 × 322 mm

17-1/8" × 5-7/8" × 12-11/16"

Weight: 8.3 kg, 18.3 lbs

REMOTE CONTROL RC-330S

Transmitter: Infrared

Signal range: Approx. 5 meters, 16 ft.

Power supply: Two "AA" batteries (1.5 V × 2)

Specifications and features are subject to change without notice.

SERVICE PROCEDURES

1. Replacing the fuses

 This symbol located near the fuse indicates that the fuse used is fast operating type. For continued protection against fire hazard, replace with same type fuse. For fuse rating refer to the marking adjacent to the symbol.

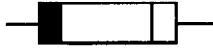
 Ce symbole indique que le fusible utilise est a rapide. Pour une protection permanents, n'utiliser que des fusibles de meme type. Ce dernier est indique la qu le present symbol est appose.

Circuit No.	Part No.	Description
F901	252163	4A-UL/T-237
F902	252073	1.6A-SE-EAK <P,WT,A>
F903	252075	2.5A-SE-EAK <P,PT>

NOTE: <D>: 120V model only
 <P>: 230V model only
 <A>: Australian model only
 <WT>: Taiwanese model only
 <PT>: Asian model only

2. To Initialize the unit

This device employs a microprocessor to perform various functions and operations. If interference generated by an external power supply, radio wave, or other electrical source results in accident which causes the specified operations and functions to operate abnormally.

To perform a reset, please follow the procedure below.

1. Press and hold down the TAPE-1 button, then press the SELECTIVE TONE CONT button.
2. After "clear" is displayed, the preset memory and each mode stored in then memory, such as surround, are initialized and will return to the factory settings.

3. Safety-check out

(Only U.S.A. model)

After correcting the original service problem, perform the following safety check before releasing the set to the customer.

Connect the insulating-resistance tester between the plug of power supply cord and the screw on the back panel.

Specifications : 3.3Mohm \pm 10% at 500V.

4. Change of voltage

Worldwide models are equipped with a voltage selector to conform to local power supplies. This switch is located on the back panel.

Be sure to set this switch to match the voltage of the power supply in your area before turning the the power switch on. This switch is set to 220-230V at the factory. Voltage is

changed by sliding the groove in the switch with the screwdriver to the right or left. Confirm that the switch has been moved all the way to the right or left before turning t power switch on.

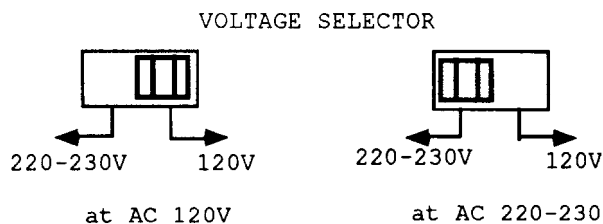

5. Memory preservation

This unit does not require memory preservation batteries.

A built-in memory power back-up system preserves contents of the memory during power failures and even when the unit is unplugged.

The unit must be plugged in and the power switch turned on and off once in order to charge the back-up system. Note that since this is not a permanent memory, the power switch must be turned on and off a few times each month the keep the back-up system operative.

The period of the time during which memory contents are preserved after power has last been turned off varies depending on climate and placement of the unit. On the average, memory contents are protected over a period of 3 to 4 weeks (a minimum of 2 weeks) after the last time power has been turned off. This period is shorted when the unit is exposed to very high humidity or used in an area with an extremely humid climate.

6. Setting the tuning step frequency

Worldwide models are equipped with a step band selector switch. This switch is located on the back papnel. This switch is set to 9 kHz at the factory, but may have to be reset to 10 kHz depending on the area where the unit is used.

AM band step
 Oher area: 9 kHz
 U.S.A. & Canada: 10 kHz

TUNER FREQ.

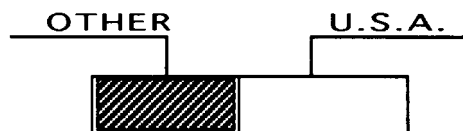

7. Changing the band step.

With the exception of the worldwide models, a tuning step selector switch is not provided. When you change the band step, change the parts as shown below.

	To 10 kHz	To 9 kHz
R727	Remove	10 ohm
R724	10 k ohm	Remove

EXPLODED VIEW

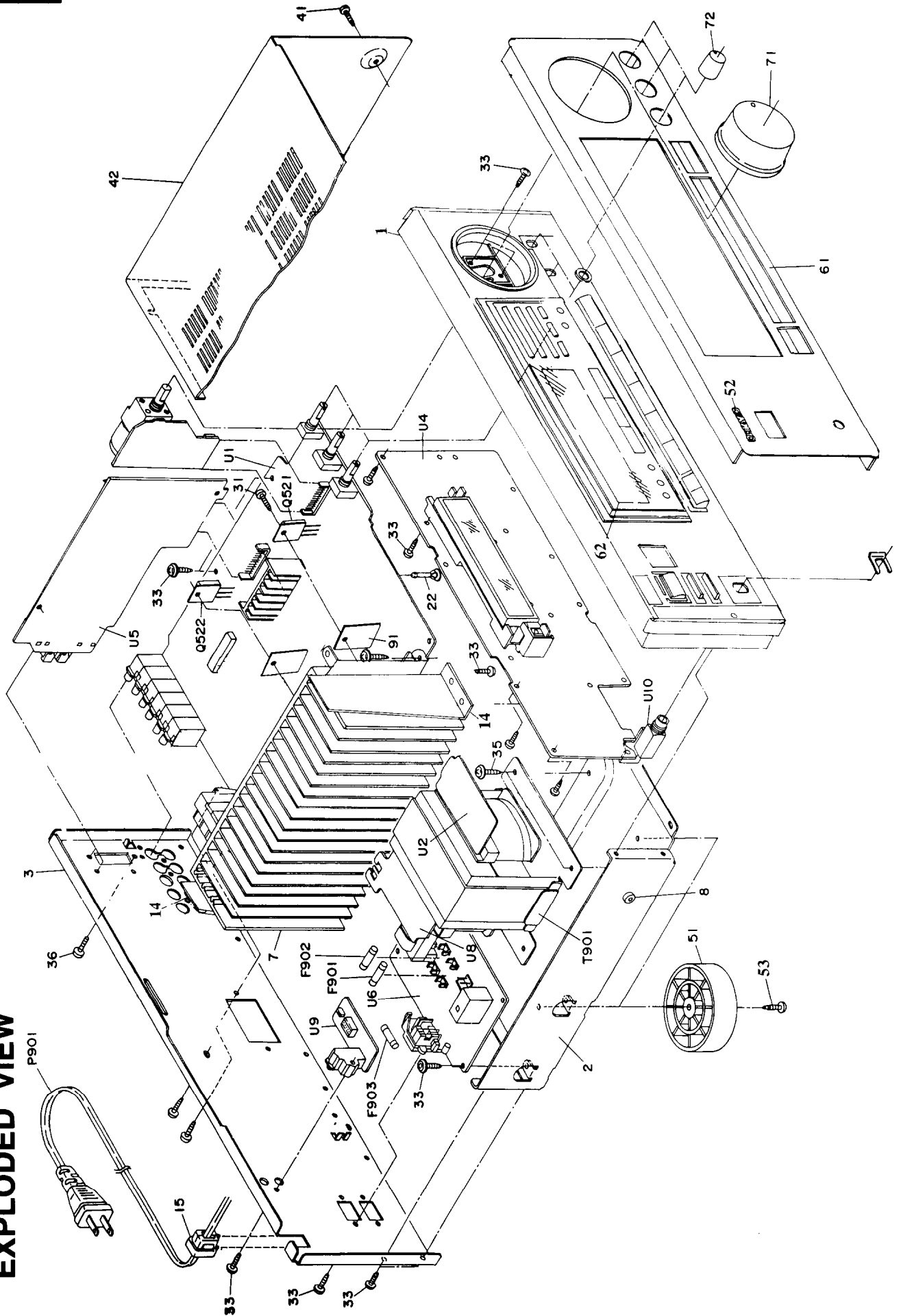

PARTS LIST

REF. NO.	PART NO.	DESCRIPTION	REF. NO.	PART NO.	DESCRIPTION
1	27110956Y	Front Bracket 	P901	253192HIT or	AS-UC-6#18, (SPT-2), Power supply cord
2	27110957Y	Front Bracket <S>	P901	253194MMAR	AS-CEE, Power supply cord <P,T>
3	27100321AY	Chassis	P901	253195MMAR	AS-SAA, Power supply cord <A>
	27122281Y	Rear Panel <D>	P901	253197HIT	AS-CEE-2, Power supply cord <W>
	27122282Y	Rear Panel <P>	P904,P905	253233KAW	NSCT-2P1357, AC Outlet <A>
	27122300Y	Rear Panel <A>	Q521,Q522	25051570	2SC5197-O, Transistor
	27122283Y	Rear Panel <PT>	Q523,Q524	2203043	2SA1940-O, Transistor
	27122284Y	Rear Panel <W, WT>	T901	2203033	NPT-1283D, Power Transformer <D>
	27160378Y	Radiator		2301220	NPT-1282P, Power Transformer <P,T,A>
11	27141530AY	Retainer (HS-2)		2301218	NPT-1282DG, Power Transformer <W>
15	27300750	AC Cord Bushing, #2271	U1	2301219	NAAR-5864-2A, Main circuit pc board ass'y <D>
22	27190991	Holder, KGFS-16RF	U2	1A723564-2AY	NAAR-5864-2B, Main circuit pc board ass'y <A,P,T,W>
28	27190266-1Y	Holder, LSR-12R	U3	1A723566-2AY	NAETC-5866, Power Supply pc board ass'y <D>
33	838130088	3TTB+8B, Self-tapping screw	U4	1A723571-2AY	NAETC-5865-2A, Volume pc board ass'y <D>
35	830440089	4TTC+8C(BC), Self-tapping screw	U4	1A723571-2BY	NAETC-5865-2B, Volume pc board ass'y <A,P,T,W>
36	27141672Y	Retainer (H)	U5	1A723571-2CY	NADIS-5871-2A, Display circuit pc board ass'y <D>
41	838430088	3TTB+8B(BC), Self-tapping screw 	U5	1A723571-2FY	NADIS-5871-2B, Display circuit pc board ass'y <P,PT>
42	838230088	3TTB+8B(NI), Self-tapping screw <S>	U5	1A723572-2AY	NADIS-5871-2C, Display circuit pc board ass'y <WT>
	28184663Y	Top Cover 	U6	1A723572-2BY	NADIS-5871-2F, Display circuit pc board ass'y <A>
	28184666Y	Top Cover <S>	U6	1A723572-2CY	NARF-5872-2A, Tuner circuit pc board ass'y <D>
51	27175319Y	Leg	U6	1A723572-2FY	NARF-5872-2B, Tuner circuit pc board ass'y <P,PT>
52	28135244Y	Badge 	U8	1A723577-2AY	NARF-5872-2C, Tuner circuit pc board ass'y <WT>
53	28135245Y	Badge <S>	U8	1A723577-2BY	NARF-5872-2F, Tuner circuit pc board ass'y <A>
53	27267955Y	Guide (POW) <P,A,PT,W,WT>	U8	1A723577-2CY	NAPS-5873-2A, Power Supply circuit pc board ass'y <D>
53	27267956Y	Guide (POW) <S><P>	U8	1A723577-2FY	NAPS-5873-2B, Power Supply circuit pc board ass'y <P,PT>
53	831430088	3TTW+8B(BC), Self-tapping screw	U8	1A723577-2AY	NAPS-5873-2C, Power Supply circuit pc board ass'y <WT>
54	28325451Y	Knob (POW) <P,A,PT,W,WT>	U9	1A723577-2BY	NAPS-5873-2F, Power Supply circuit pc board ass'y <A>
54	28325458Y	Knob (POW) <S><P>	U9	1A723577-2CY	NAETC-5877-2A, Primary pc board ass'y <D>
61	27211873Y	Front Panel <D>	U9	1A723577-2FY	NAETC-5877-2B, Primary pc board ass'y <P,PT>
	27211874Y	Front Panel <P,A,PT>	U9	1A723577-2AY	NAETC-5877-2A, Primary pc board ass'y <A>
	27211875Y	Front Panel <W, WT>	U9	1A723575-2AY	NADIS-5875-2A, RI Terminal pc board ass'y <D>
	27211876Y	Front Panel <S><P>	U9	1A723575-2BY	NADIS-5875-2B, RI Terminal pc board ass'y <P,PT>
62	28191756AY	Clear Plate <D,PT,W,WT>	U10	1A723575-2CY	NADIS-5875-2C, RI Terminal pc board ass'y <WT>
	28191757AY	Clear Plate <P,A>	U10	1A723575-2FY	NADIS-5875-2F, RI Terminal pc board ass'y <A>
	28191758AY	Clear Plate <S><P>	U10	1A723578-2AY	NAETC-5878-2A, Headphone pc board ass'y <D>
71	28325456Y	Knob (VOL) 	U10	1A723578-2BY	NAETC-5878-2B, Headphone pc board ass'y <P,PT>
	28325457Y	Knob (VOL) <S>	U10	1A723578-2FY	NAETC-5878-2C, Headphone pc board ass'y <WT>
72	28325454Y	Knob (TONE) 	U10	1A723578-2AY	NAETC-5878-2F, Headphone pc board ass'y <A>
	28325455Y	Knob (TONE) <S>	U10	1A723578-2BY	NAETC-5878-2B, Headphone pc board ass'y <D>
91	223024	AC238, Isolation Sheet	U10	1A723578-2FY	NAETC-5878-2C, Headphone pc board ass'y <P,PT>
F901	252163	4A-UL, T-237, Fuse	U10	1A723578-2AY	NAETC-5878-2F, Headphone pc board ass'y <WT>
F902	252073	1.6A-SE-EAK, Fuse <P,W,T,A>	U10	1A723578-2BY	NAETC-5878-2B, Headphone pc board ass'y <D>
F903	252075	2.5A-SE-EAK, Fuse <P,T>	U10	1A723578-2FY	NAETC-5878-2C, Headphone pc board ass'y <P,PT>
P711	2047311512	NCFC7-311512, Flat Flaskible Cabel	U10	1A723578-2AY	NAETC-5878-2F, Headphone pc board ass'y <WT>

NOTE: <D>: 120V model only
 <P>: 230V model only
 <A>: Australian model only
 <WT>: Taiwanese model only
 <PT>: Asian model only

NOTE: THE COMPONENTS IDENTIFIED BY MARK Δ ARE CRITICAL FOR RISK OF FIRE AND ELECTRIC SHOCK. REPLACE ONLY WITH PART NUMBER SPECIFIED.

BLOCK DIAGRAM

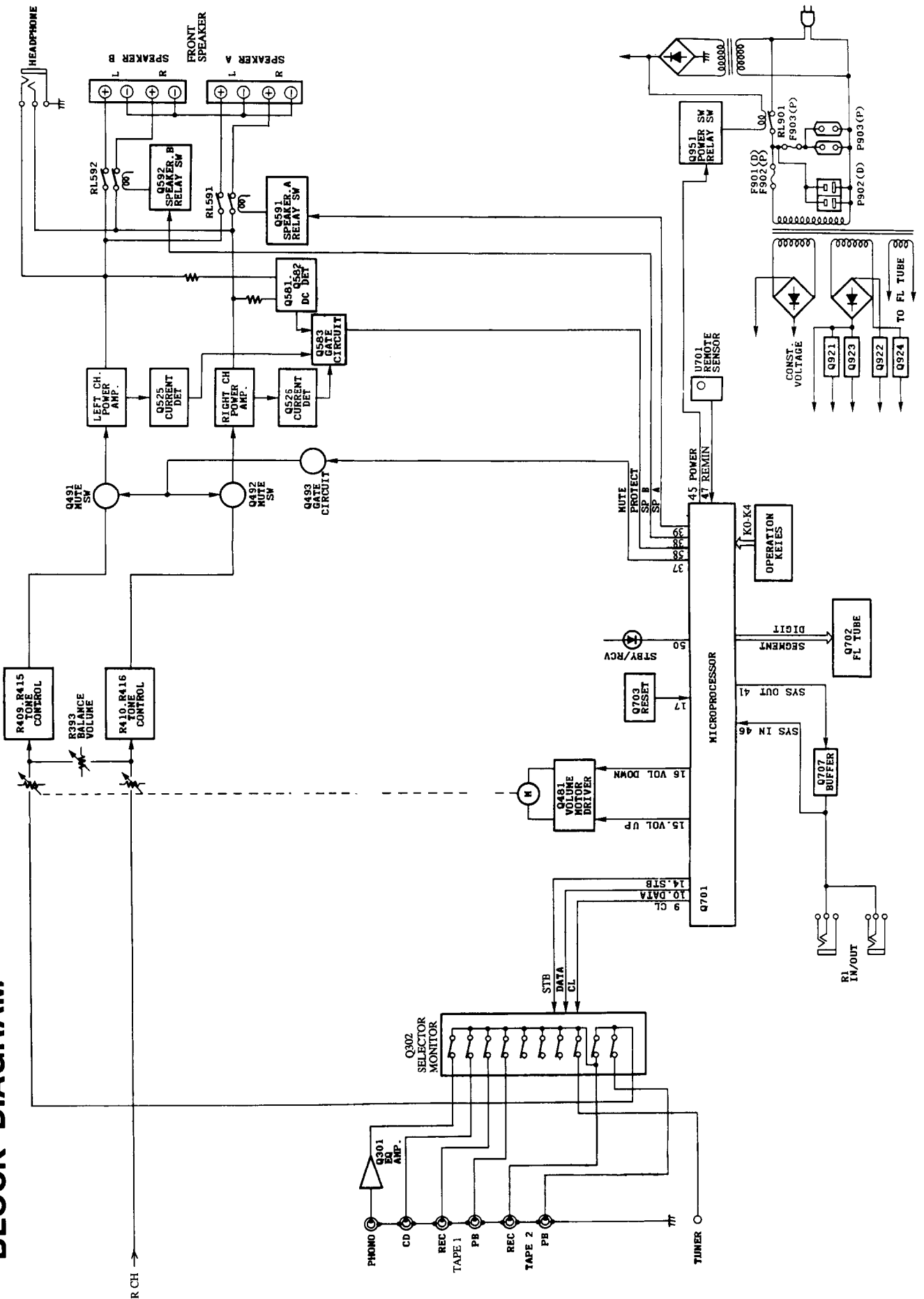

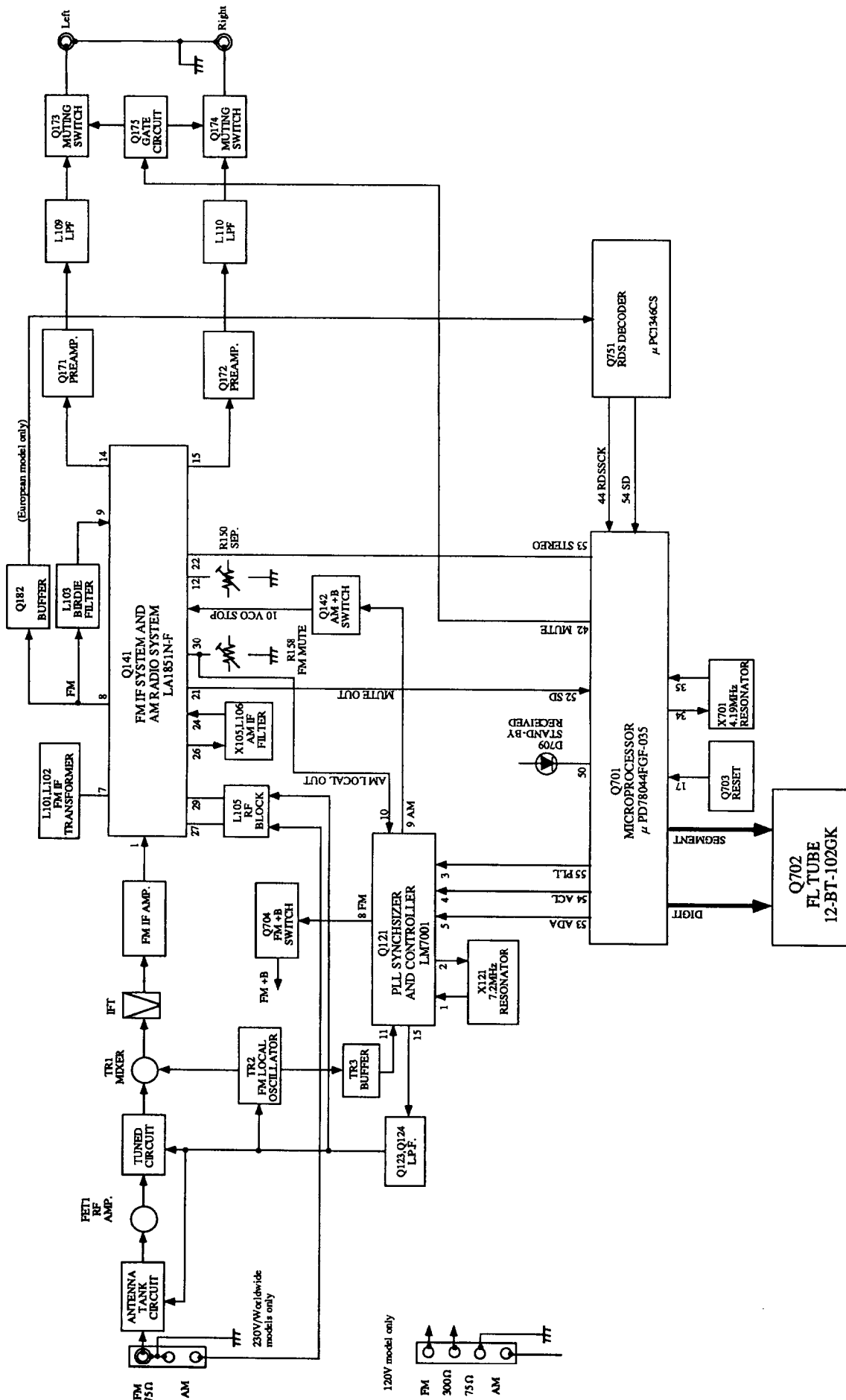

MICROPROCESSOR CONNECTION DIAGRAM

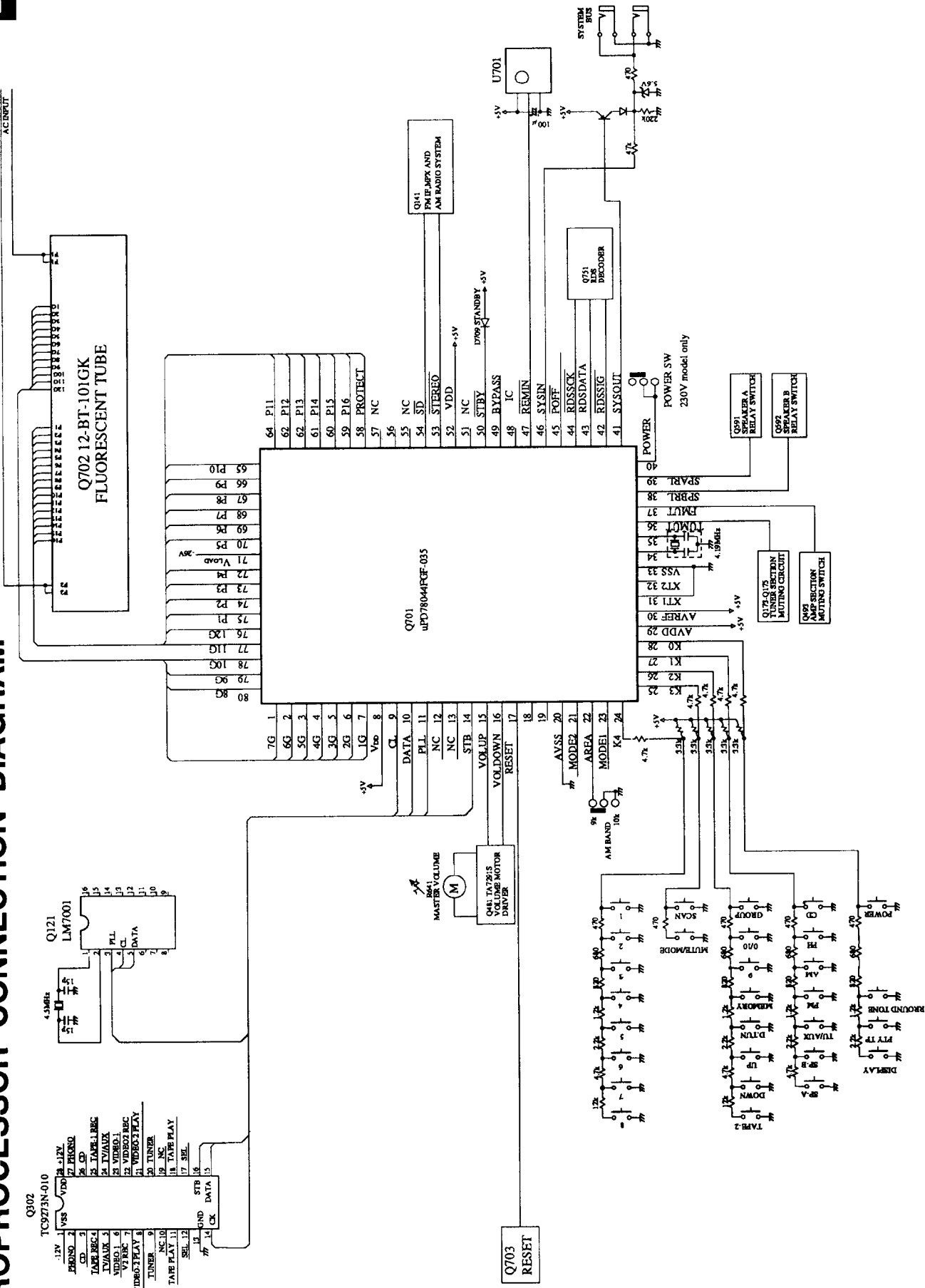

TERMINAL DESCRIPTION

μ PD78044FGF-035

Q701 μ PD78044FGF-035

Pin No.	Function	I/O	Description
1~7	7G~1G	O	Grid control output pin. On at the high level.
8	VDD		Power supply pin (+5V)
9	CL	O	Clock output pin. Connect to the terminals CK of function switch Q302, and PLL IC Q121.
10	DATA	O	Data output pin. Connect to the terminals DATA of function switch Q302, and PLL IC Q121.
11	PLL	O	Chip enable output pin for PLL IC Q121.
12	NC		Not used.
13	NC		Not used.
14	STB	O	Chip enable output pin. Connect to the terminal STB of function switch Q302.
15	VOLUP	O	Volume control output pin.
16	VOLDOWN	O	Volume control output pin. (Refer table 1.)
17	RESET	I	System reset input pin
18	NC		Not used.
19	NC		Not used.
20	AVSS		Ground pin of A/D converter
21	MODE2	I	A or B setting input pin.
22	AREA	I	Initializing input of band region
23	MODE1	I	Initializing input of operation mode
24	K4	I	Operation key connection pin
25	K3	I	Operation key connection pin
26	K2	I	Operation key connection pin
27	K1	I	Operation key connection pin
28	K0	I	Operation key connection pin
29	AVDD		Analogue power supply of A/D converter
30	AVREF		Reference voltage input pin of A/D converter
31	XT1		Crystal connection pin for sub system clock resonator
32	XT2		Not used.
33	VSS		Ground pin
34	X1		Resonator connection terminal for main system clock
35	X2		Connect the ceramic resonator 4.19MHz.
36	TUMUT	O	Muting output pin for tuner section.
37	FRONTMUT	O	Muting output pin for front amp.
38	SPBRL	O	Relay control pin for speaker B
39	SPARL	O	Relay control pin for speaker A.
40	POWER	O	Power source control output pin
41	SYSOUT	O	System code output pin
42	RDSSIG	I	Detector input pin of RDS broadcast. L:RDS broadcast
43	RDSDATA	I	Data input pin from RDS decoder uPD1346CS
44	RDSSCK	I	Clock input pin from RDS decoder IC uPC1346CS
45	POFF	I	Power stoppage detector input pin
46	SYSIN	I	System code input pin
47	REMIN	I	Remote control signal input pin
48	NC		Not used.
49	NC		Not used.
50	STBY/RCV	O	Standby and received indicator output pin
51	S. TONE		Selective tone control pin
52	VDD		Power supply pin (+5V)
53	STEREO	I	Detector input pin of FM stereo broadcast
54	SD	I	Detector input pin of broadcast more than muting level
55	MROFF		Multi reem indicator
56	NC		Not used
57	RFIN	I	RF mode input pin
58	PROTECT		Detector input pin of protection circuit.
59~70	P16 - P5	O	Segment output pins. On at the high level.
71	VLOAD	I	Pull-down resistor connection pin of controller and driver of FL.
72~75	P4 - P1	O	Segment output pins. On at the high level.
76~80	12G~8G	O	Grid control output pins. On at the high level.

Operation	#15	#16
VOLUME UP	H	L
VOLUME DOWN	L	H
STOP	H	H

Table 1

ADJUSTMENT PROCEDURES

Preparation

1. Input

FM mono: 1 kHz, 75 kHz devi., 60 dB/ μ V

FM stereo: 1 kHz, 7.5 kHz devi., 60 dB/ μ V

Pilot signal :19 kHz,7.5 kHz devi.

AM : 400Hz ,30% mod.

2. Outputs

Connect the non-inductive type resistors of 8 ohms to the speaker terminals A unless otherwise noted.

3. Standard Knob Positions

Master Volume Control	Maximum
Bass Control	Center
Treble Control	Center
Balance Control	Center
Input Selector.....	CD
Tape 2 Monitor.....	CD
Muting	Off
Selective tone	Off
Speaker	A on, B off

IDLING CURRENT ADJUSTMENT

1. Connect the DC voltmeter to the terminals P521 and P522(VCT and IID) on the main circuit pc board.

2. Adjust the trim resistors R533 and R534 so that the indicator of voltmeter becomes 2.0mV.

3. After 4 - 6 minutes of heat runing, readjust R533 and R534 to get 4.8 - 5.2mV.

NOTE: Set Volume knob to the minimum position.

Set the unit to the test mode.

1. Press and hold down the CD button, then press the Power button.
2. "TEST-" is displayed on the display.
3. While "TEST-" is displayed, press the FM key.

FM ADJUSTMENT

Item	Step	Connection of instrument	FM SG output	Stereo modulator output	Tuning frequency	Output indicator	Adjustment point	Adjust for	Remarks
FM IF/RF	1	Fig.1	99.0MHz 1kHz 75kHz devi. 65dBf(60dB)	—	99.0MHz	DC voltmeter	L101	0±20mV	FM MUTE/MODE switch:ON/STEREO Repeat the steps 1 and 3 until no further adjustment is necessary.
	AC voltmeter					IFT on the front end	Maximum		
	Distortion analyzer					L102	Minimum		
Stereo Distortion		Fig.2	99.0MHz Ext. mod.65dBf(60dB)	Channel L or R 1kHz	99.0MHz	Distortion analyzer	IFT on the front end	Minimum	Don't turn more than ±180°
Stereo Separation	1	Fig.2	99.0MHz Ext. mod. 65dBf(60dB)	Channel L 1kHz	99.0MHz	Channel R AC voltmeter	R150	Minimum	Maximum and same separation
	2			Channel R 1kHz		Channel L AC voltmeter		Minimum	
Muting Level		Fig.2	99.0MHz 21.2dBf(16dB) <P/W Models> 23.2dbF(18dB) <D model>	—	99.0MHz	Oscilloscope or TUNED indicator	R158	Signal output or light on	
RDS		Fig.3	99.0MHz Ext. mod.40dB	RDS data or 57kHz 3% devi.	99.0MHz	Oscilloscope	R786	Maximum	European model only

AM ADJUSTMENT

120V model

Step	AM SG output	Tuning Frequency	Output Indicator	Adjustment point	Adjust for
1		530kHz	Digital DC voltmeter	OSC coil on RF block L151	1.3±0.1V
2	600kHz 400Hz 30% mod. 60dB/m	600kHz	AC voltmeter	RF coil on RF block L105	Maximum
3	999kHz 400Hz 30% mod. 60dB/m	990kHz	AC voltmeter	L106	Maximum

Reference Specification

FM tuned voltage: 87.9MHz~107.9MHz
More than 1.3V~Less than 10V
AM tuned voltage: 530kHz~1710kHz
1.3±0.2V~Less than 9.0V

230V and worldwide models

Step	AM SG output	Tuning Frequency	Output Indicator	Adjustment point	Adjust for
1		522kHz or 531kHz	Digital DC voltmeter	OSC coil on RF block L151	1.3±0.1V
2	603kHz 400Hz 30% mod. 60dB/m	603kHz	AC voltmeter	RF coil on RF block L105	Maximum
3	999kHz 400Hz 30% mod. 60dB/m	999kHz	AC voltmeter	L106	Maximum

Reference Specification

FM tuned voltage: 87.5MHz~108.0MHz
more than 1.3V ~Less than 10V
AM tuned voltage: 522kHz~1611kHz
1.3±0.2V~Less than 9.0V
(230V model)
AM tuned voltage: 531kHz~1602kHz
1.3±0.2V~Less than 9.0V
(Worldwide model)

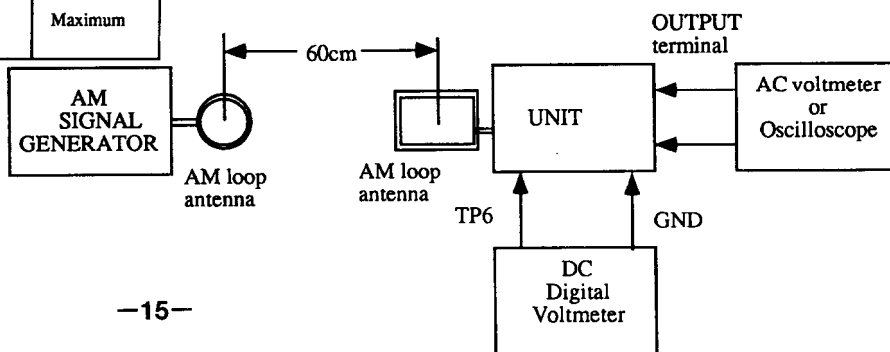

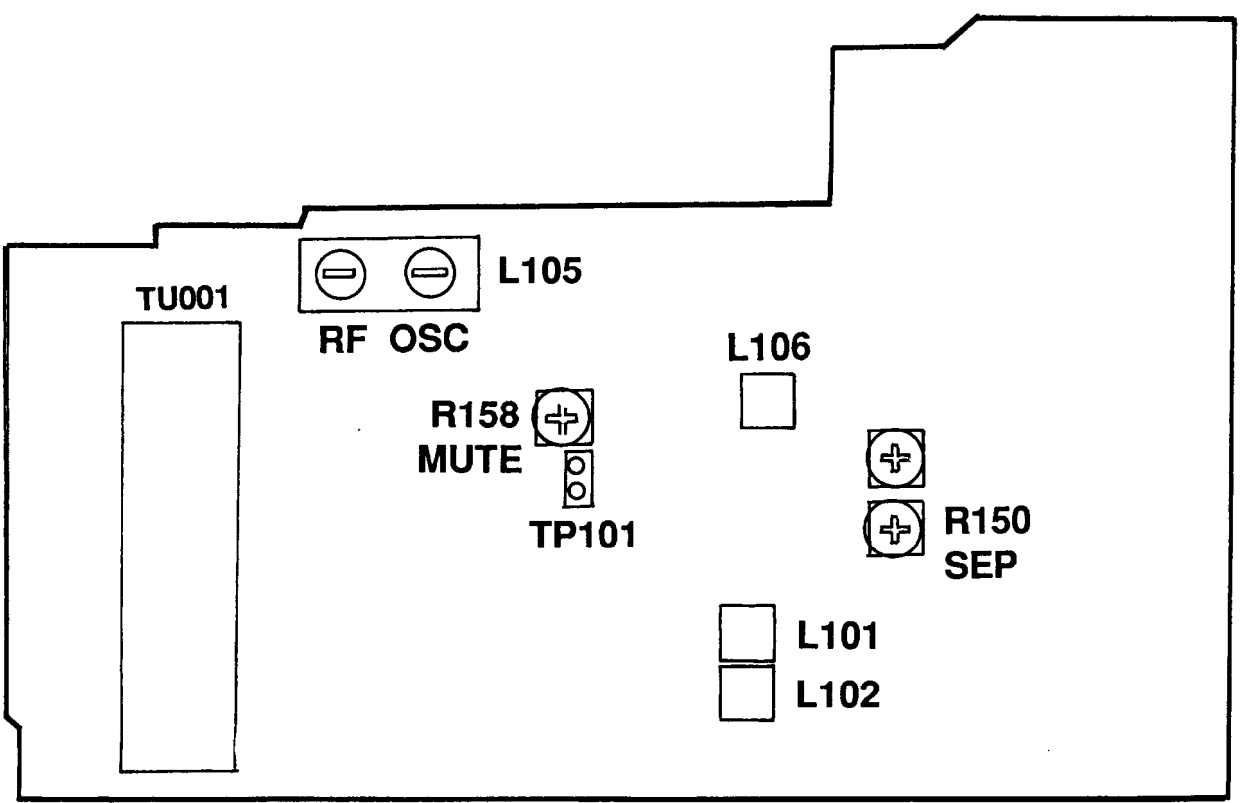
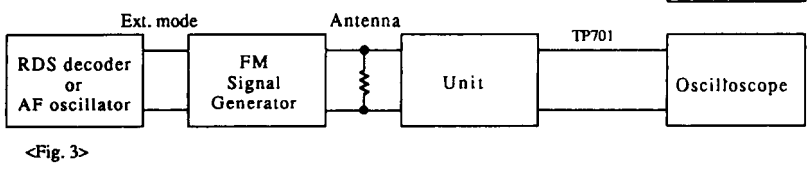
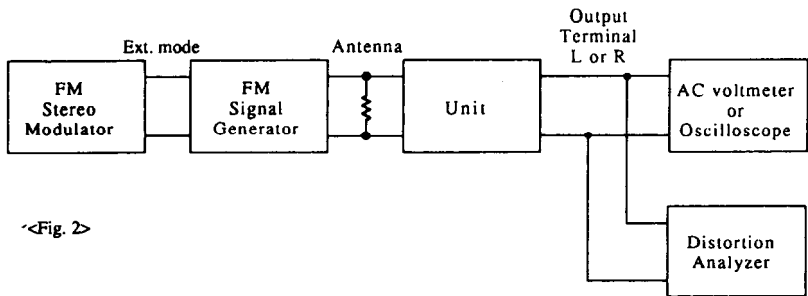
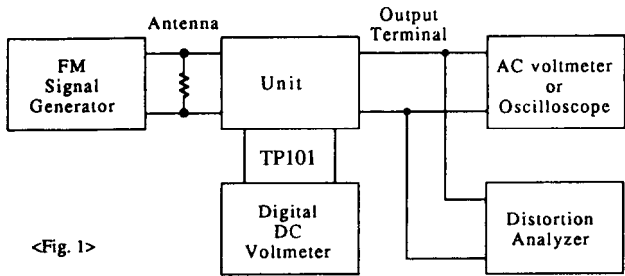

PRINTED CIRCUIT BOARD-PARTS LIST

U1 MAIN CIRCUIT PC BOARD (NAAR-5864)

CIRCUIT NO.	PART NO.	DESCRIPTION
	ICs	
Q301	222502	NJM4558D-X
Q302	22240881	TC9273N-010
Q401,Q402	22240250	NJM2068L-D
Q481	22240239	TA7291S
Q921	222780125NEC	MPC78M12AHF
Q922	222790125	79M12HF
Q923	222780565JRC	NJM78M56FA
	Transistors	
Q403-Q406	2211945	2SK246-GR
Q407,Q493	2213510 or 2214350	DTA114ES or RN2202
Q491,Q492	2213631	RN1241-A
Q501-Q504	2211733 or 2211732	2SC1845-E or 2SC1845-F
Q505,Q506	2211353	2SA949-O
Q507,Q508	2211733 or 2211732	2SC1845-E or 2SC1845-F
Q509,Q510	2213284	2SC1740S-R
Q511,Q512	2211353	2SA949-O
Q513,Q514	2211633	2SC2229-O
Q515,Q516	2213284	2SC1740S-R
Q517,Q518	2203010	2SC5171
Q519,Q520	2203000	2SA1930
Q525,Q526	2211733 or 2211732	2SC1845-E or 2SC1845-F
Q527,Q528	2211353	2SA949-O
Q529,Q530	2211633	2SC2229-O
Q581,Q582	2211733 or 2211732	2SC1845-E or 2SC1845-F
Q583	2211792	2SA992-F
Q591,Q592	2213640	DTC123JS
Q924	2211455	2SA1015-GR
	Diodes	
D401-D404	223163 or 223205	1SS133 or 1SS270A
D501,D502	22380260 or 22380032	RL1N4003 or 1SR139-100, GP104003E
D591,D592	223163 or 223205	1SS133 or 1SS270A
D911	22380271F or 22380022F	△ D3SB A20 or RBV402
D915-D921	22380260 or 22380032	△ RL1N4003 or 1SR139-100, GP104003E
D922	224472704	MTZJ27D, Zener
D923	223163 or 223205	1SS133 or 1SS270A
	Coils	
L501,L502	231176S	S-1.3C
	Capacitors	
C303,304	354741009	10 μ F,16V, Elect.
C307,C308	354721019	100 μ F,6.3V, Elect.
C309,C310	374726224	6200pF \pm 5%,50V,Plastic
C311,C312	374721824	1800pF \pm 5%,50V,Plastic
C313-C316	354741009	10 μ F,16V, Elect.
C391,C392	374721015	100pF \pm 10%,50V,Plastic
C407,C408	354741009	10 μ F,16V, Elect.
C401,C402	354741009	10 μ F,16V, Elect.
C411,C412	354741009	10 μ F,16V, Elect.
C413-C416	374721044	0.1 μ F \pm 5%,50V,Plastic
C417-C420	374721024	1000pF \pm 5%,50V,Plastic
C421-C422	374721534	0.015 μ F \pm 5%,50V,Plastic
C433-C434	374721534	0.015 μ F \pm 5%,50V,Plastic
C435,C436	374721015	100pF \pm 10%,50V,Plastic
C437	374721044	0.1 μ F \pm 5%,50V,Plastic
C441	354721019	100 μ F,6.3V, Elect.
C442	354780479	4.7 μ F,50V, Elect.
C501,C502	354781009	10 μ F,50V, Elect.
C503,C504	374721015	100pF \pm 10%,50V,Plastic
C507,C508	354724719	470 μ F,6.3V Elect.
C513,C514	354722219	220 μ F,6.3V, Elect.

CIRCUIT NO.	PART NO.	DESCRIPTION
C515,C516	354784719	470 μ F,50V, Elect.
C521,C522	354784709	47 μ F,50V, Elect.
C529,C530	374721044	0.1 μ F \pm 5%,50V,Plastic
C581	354721019	100 μ F,6.3V, Elect.
C911	374731034	0.01 μ F \pm 5%,50V,Plastic
C915,C916	3504207S	6800 μ F,50V, Elect.
C918	354761029	1000 μ F,35V, Elect.
C919	354763319	330 μ F,35V, Elect.
C922-C925	354781009	10 μ F,50V, Elect.
C926	354761019	100 μ F,35V, Elect.
C928	354781019	100 μ F,50V, Elect.
C932	354781009	10 μ F,50V, Elect.
C983	374721034	0.01 μ F \pm 5%,50V,Plastic
	Resistors	
R409,R415	5104356	N14RLC, 100KWT20Z, BASS, TREBEL
R511,R512	443525604	56ohm \pm 5%,1/2W, Metal oxid
R529-R532	443526804	68ohm \pm 5%, 1/2W, Metal oxid
R533,R534	5210259	N06HR, 2KBC, Trim
R539,R540	443526804	68ohm \pm 5%, 1/2W, Metal oxid
R541,R542	443525604	56ohm \pm 5%,1/2W, Metal oxid
R545,R546	4000131	0.22ohm \pm 10%, Metal plate
R551,R552	453630824	8.2ohm \pm 5%, 1W, Metal
R563,R564	453530224	2.2ohm \pm 5%, 1/2W, Metal
R565,R566	443623914	390ohm \pm 5%, 1W, Metal oxid
R581,R582	443523314	330ohm \pm 5%, 1/2W, Metal oxid
R583-R586	453530224	2.2ohm \pm 5%, 1/2W, Metal
	Relays	
RL591,RL592	25065517 or 25065485	NRL-2P5A-DC24-098 or NRL-2P2A-DC24-086
	Plugs	
P211a	25055709	NPLG-13P665
P521,P522	25055038	NPLG-2P29
P613a	25055706	NPLG-10P664
	Pin Jack	
P301,P302	25045458 or 25045300	NPJ-6PDBL279 or NPJ-6PDBL159
	Sockets	
P711a	25051838 or 25051297	NSCT-31P1625 or NSCT-31P1086, NSCT-31P758
	Terminal	
P501	25060224 or 25060158	NTM-8PDML146 or NTM-8PDML084
	Radiators	
D911a	27160166	(D911)
Q921a	27160209	RAD-67,Q921

U2 POWER SUPPLY PC BOARD (NAETC-5866)

CIRCUIT NO.	PART NO.	DESCRIPTION
	Resistors	
R921,R922	453530104	△ 1ohm \pm 5%, 1/2W, Metal

U3 VOLUME PC BOARD (NAETC-5865)

CIRCUIT NO.	PART NO.	DESCRIPTION
	Resistor	
R641	5104334	N16RGL100KBT, 25F, VOLUME
	Socket	
P613b	25051235	NSCT10P1025

U4 DISPLAY CIRCUIT PC BOARD (NADIS-5871)

CIRCUIT NO.	PART NO.	DESCRIPTION
	Remote sensor	
U701	24130011	PIC-12043TE2
	ICs	
Q701	22241057	μ PD78044FGF-035
Q751	22240679	μ PC1346CS <A.P.P.T>
	Transistors	
Q703	221282	DTC144ES
Q705,Q706	2213284	2SC1740S-R
Q707	2213510	DTA114ES

CIRCUIT NO.	PART NO.	DESCRIPTION	CIRCUIT NO.	PART NO.	DESCRIPTION
D701,D702	223163 or 223205	1SS133 or 1SS270A	D101,D102	223191	SD101
D703	224470913	MTZJ9.1C, Zener	D165	224470512	MTZJ5.1B, Zener
D704,D705,D708	223163 or 223205	1SS133 or 1SS270A	Coils and Transformers		
D706,D707	224470562	MTZJ5.6B, Zener	L101	233457	NFIF-4081, IF Trans
D709	225290	SEL4110R, LED	L102	233458	NFIF-4082, IF Trans
D710-D712	223163 or 223205	1SS133 or 1SS270A	L103	233471	NMC-6084 <P>
D751	223163 or 223205	1SS133 or <A,P,PT> 1SS270A	L104	233454K220	NCH-1452, 220K
L701-L703	233454K220	NCH-1452, 220K	L105	232174	NMRF-5077, RF Block
X701	3010163	CST-4.19MGW, Ceramic Lock	L106	232139	NMIF-4062, IF Trans
X751	3010203	AF6146CG, Crystal <A,P,T>	L107	233484	NMC-4085 <P>
C701	3000076 or 3000078	0.1F,5.5V, Sppper Elect.	L108	233484	NMC-4085 <P>
C702	375524744	0.47 μ F \pm 5%,50V, Plastic	L109,L110	231092	NCH-2140 <D>
C703,C709,C711	354721019	100 μ F,6.3V, Elect.	Ceramic Filters		
C704,C706,C707	353780109	1 μ F,50V, Elect.	X101,X103	3010071	SFE10.7MA5, (RED), Ceramic Filter
C751	354721019	100 μ F,6.3V,Elect. <A,P,PT>	X102	3010130	SFE10.7MZ2A, CERA FIL <A,P,PT>
C754	374724724	4700pF \pm 5%,50V, Plastic <A,P,PT>	X105	3010123	SFZ-450JL, Ceramic Filter
C755,C756	374723324	3300pF \pm 5%,50V, Plastic <A,P,PT>	Resonators		
C757	354780229	2.2 μ F,50V, Elect. <A,P,PT>	X104	3010268	CSB456F23, Ceramic Lock
C758	374724734	0.047 μ F \pm 5%,50V, Plastic <A,P,PT>	X121	3010141	X1L-7.2M, Srystal
C759	374722234	0.022 μ F \pm 5%,50V, Plastic <A,P,PT>	Capacitors		
C760	374724724	4700pF \pm 5%,50V, Plastic <A,P,PT>	C001,C133,C142	354741019	100 μ F,16V, Elect.
R786	5210265	N06HR, 50KBC, Trim <A,P,PT>	C106	354742209	22 μ F,16V, Elect.
Q702	212157	12-BT-102GK	C107,C160	354784799	0.47 μ F,50V, Elect.
S701	25035652	NPS-111-S604 <D>	C127	354721019	100 μ F,6.3V, Elect.
S704	25035652	NPS-111-S604	C130,C159,C177	354780229	2.2 μ F,50V, Elect.
S705,S706	25035652	NPS-111-S604 <A,P,T>	C131,C146	374722234	0.022 μ F \pm 5%, 50V, Plstic
S707-S713	25035652	NPS-111-S604	C132,C153	354783399	0.33 μ F,50V, Elect.
S715-S724	25035652	NPS-111-S604	C145,C154,C166	354741009	10 μ F, 16V,Elect.
S731-S738	25035652	NPS-111-S604	C147	374721534	0.015 μ F \pm 5%,50V, Plastic <D>
S739	25035653	NPS-122-L605, Power <A,P,PT,WT>	C149	374721034	0.01 μ F \pm 5%,50V,Plastic <A,P,PT>
P211b	25051238	NSCT-13P1028	C151,C152	354780479	4.7 μ F,50V, Elect.
P711b	25051875 or 25051335	NSCT-31P1662 or NSCT-31P1124, NSCT-31P727	C155,C156	354780109	1 μ F,50V, Elect.
TP101	25055038	NPLG-2P29	C171,C172,C178	374721034	0.01 μ F \pm 5%,50V,Plastic <D>
TP701	25055038	NPLG-2P29 <A,P,PT>	C162	374724724	4700pF \pm 5%,50V,Plastic <A,P,T>
Q702a	27190989	FL tube	C175,C176	374725624	5600pF \pm 5%,50V,Plastic <WT>
U5 TUNER CIRCUIT PC BOARD (NARF-5872)			C175,C176	374722724	10 μ F,16V,Elect.
CIRCUIT NO.	PART NO.	DESCRIPTION	R150	5210261	10 μ F,16V,Elect.
	Front End		R158	5210264	1000pF \pm 5%, 50V, Plastic
TU001	240104	ENV172D2G1 <D>	2700pF \pm 5%,50V, Plastic <A,P,PT>		
	240103	ENV172A2G1 <P,PT,WT,A>	Resistor		
	ICs		N06HR, 5KBC, Separation		
Q121	22240090	LM7001	N06HR, 30KBC, Mute		
Q141	22240983	LA1851N-F	Terminals		
Q101	2210746	2SC945A-P <A,P,PT,WT>	P101	25060239 or	NTM-4PDML161 or <D>
Q102	2211723	2SC1923-O		25060195	NTM-4PDML117
Q105,Q124	2213284	2SC1740S-R		25060222 or	NTM-2PDML144 or <P,pT,A>
Q122,Q142,Q175	2213510	DTA114ES		25060117	NTM-2PDML051
Q123	2212445	2SK365-GR		Shield Plate	
Q143	221282	DTC144ES		27150397	(Tuner) <A,PT,WT>
Q144	2213640	DTC123JS	U6 POWER SUPPLY PC BOARD (NAPS-5873)		
Q171,Q172	2213284	2SC1740S-R	CIRCUIT NO.	PART NO.	DESCRIPTION
Q173,Q174	2212794	2SD1468-R	Q951	2213284	2SC1740S-R
Q182	2213284	2SC1740S-R <A,P,PT>	Transistor		
			D951-D954	22380260 or	RL1N4003 or
			D955	22380032	1SR139-100, GP104003E
				223163 or	1SS133 or
				223205	1SS270A
				Transformer	
			T902	2300670A	NPT-1111D <D>
				2300671A	NPT-1111P <P,PT,A>
				2300672A	NPT-1111DG <WT>
				Capacitors	
			C901	3500191	DE7150F0.01 μ F, IS C
			C952	354742219	220 μ F,16V, Elect.
				Resistors	
			R901	431533355	3.3M ohm, 1/2W, Solid <D>
			R951	453530824	8.2ohm \pm 5%,1/2w, Metal
				Switch	
			S901	25065437	NSS-22157P, Voltage Selector <WT>

CIRCUIT NO.	PART NO.	DESCRIPTION
	Plug	
P901a	25055675	△ NPLG-2P631
	Relays	
RL901	25065515 or 25065508	△ NRL-1P5A-DC12-096 or △ NRL-1P10A-DC12-093
	Fuse Holders	
F901a	25050065	YSH403T <D,WT>
F902a	25050065	YSH403T <P,PT,WT,A>
F903a	25050065	YSH403T <P,PT>
	AC Outlets	
P902	25051126	NSCT-4P913 <D>
P903	25051125	NSCT-4P912 <P,PT,WT>

U9 RI TERMINAL PC BOARD (NADIS-5875)

CIRCUIT NO.	PART NO.	DESCRIPTION
	Switch	
S961	25065286	NSS-22112, AM Band switch <WT>
	Jack	
P961	25045481	NPJ-2PDBL299, RI Terminal

U10 HEADPHONE PC BOARD (NAETC-5878)

CIRCUIT NO.	PART NO.	DESCRIPTION
	Jack	
P503	25045255	YKB21-5009, Headphone

NOTE: THE COMPONENTS IDENTIFIED BY MARK △ ARE CRITICAL FOR RISK OF FIRE AND ELECTRIC SHOCK. REPLACE ONLY WITH PART NUMBER SPECIFIED.

NOTE: <D>: 120V model only
<P>: 230V model only
<A>: Australian model only
<WT>: Taiwanese model only
<PT>: Asian model only

ANODE CONNECTION

	12G	11G	10G-6G	5G	4G	3G	2G	1G
P1	A P R	SPEAKERS	a	a	a	a	a	a
P2		A	h	h	h	h	-	GROUP
P3	STEREO MODE ▽	B	j	j	j	j	-	SLEEP
P4	AUTO	T-2 MONITOR	k	k	k	k	-	E.DAY
P5	MONO	VIDEO	b	b	b	b	b	b
P6	RF MODE ▽	[1]	f	f	f	f	f	f
P7	LOCAL	[2]	m	m	m	m	-	ONCE
P8	DX	AUDIO MUTE	g	g	g	g	g	g
P9	-	[STC]	c	c	c	c	c	c
P10	-	FM MUTE	e	e	e	e	e	e
P11	-	ON	r	r	r	r	-	A
P12	-	OFF	p	p	p	p	-	B
P13	-	TUNED	n	n	n	n	-	C
P14	-	▷ ▽	d	d	d	d	d	d
P15	-	STEREO	-	col	-	KHZ	MEMORY	CH
P16	-	-	-	DP	-	MHZ	RDS	MIN

ONKYO CORPORATION

International Sales Div. : 31 Sankyo-bld. 3-8-5, Asakusabashi, Taito-ku, TOKYO 111, JAPAN
TEL : 03-5820-5865 FAX : 03-5820-5869

ONKYO U.S.A. CORPORATION
200 Williams Drive, Ramsey, N.J. 07446, U.S.A.
TEL : 201-825-7950 FAX : 201-825-8150

ONKYO EUROPE ELECTRONICS GmbH
Industriestrasse 18-20, 82110 Germering, GERMANY
TEL : 089 84 93 20 FAX : 089 84 93 226

ONKYO FRANCE
Immeuble Le Diamant, Domaine Technologique de Saclay, 4 Rue Rene Razel, 91892 SACLAY, FRANCE
TEL : (1) 69 33 14 00 FAX : (1) 69 41 35 84

*Parts

	C147	C150	C155 C156	C173 C174	C175 C176	R107	R142	R145 R146	R147	R153 R154
Dtype	153J	NONE	103J	102J	NONE	1K	33K	NONE	Shorted	8.2K
P/PT	103J	471K	472J	NONE	272J	470	68K	Shorted	NONE	15K
Wtype	103J	471K	562J	NONE	272J	470	68K	Shorted	NONE	15K

	R723	R724	R725	R726	R727	R755	R783	C575 C576
Dtype	8.2K	10K	NONE	33K	NONE	10	NONE	NONE
P/PT	10K	NONE	NONE	NONE	10	10	NONE	102
Wtype	10K	3.3K	NONE	5.6K	5.6K	10	560	102

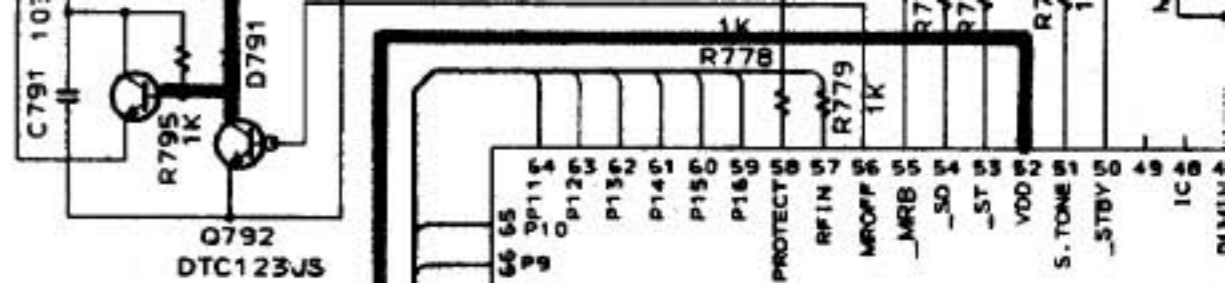

NADIS-5918

