

# ONKYO SERVICE MANUAL

## QUARTZ SYNTHESIZED TUNER AMPLIFIER MODEL TX-822

### Black model

BHUD, BHUDN	120V AC, 60Hz
BHUG	220V AC, 50Hz
BHUQA, BHUQB	240V AC, 50Hz
BHUW	120 or 220V AC, 50/60Hz

### SAFETY-RELATED COMPONENT WARNING!!

COMPONENTS IDENTIFIED BY MARK  $\Delta$  ON THE SCHEMATIC DIAGRAM AND IN THE PARTS LIST ARE CRITICAL FOR RISK OF FIRE AND ELECTRIC SHOCK. REPLACE THESE COMPONENTS WITH ONKYO PARTS WHOSE PART NUMBERS APPEAR AS SHOWN IN THIS MANUAL.

MAKE LEAKAGE-CURRENT OR RESISTANCE MEASUREMENTS TO DETERMINE THAT EXPOSED PARTS ARE ACCEPTABLY INSULATED FROM THE SUPPLY CIRCUIT BEFORE RETURNING THE APPLIANCE TO THE CUSTOMER.

### TABLE OF CONTENTS

Specifications	2
Service procedures	3
Exploded view	4
Parts list	5
IC block diagram and descriptions	6
Adjustment procedures	13
Printed circuit board views	15
Main circuit	15
Display	15
Other pc boards	23
Semi-conductor views	16
Schematic diagram	17
120V model	17
Other models	21
Pc board-parts list	19
Block diagram	24
Packing view	26



# SPECIFICATIONS

## AMPLIFIER SECTION

Power output:	40 watts (50 watts : only 120V model) per channel, min, RMS, at 8 ohms, both channels driven, from 40Hz to 20kHz, with no more than 0.3% total harmonic distortion.	
Musical Power Output:	2 × 95 watts at 4 ohms, 1kHz (DIN) 2 × 68 watts at 8 ohms, 1kHz (DIN)	
Continuous Power Output:	2 × 50 watts at 4 ohms, 1kHz (DIN) 2 × 45 watts at 8 ohms, 1kHz (DIN)	
Total Harmonic Distortion:	0.3% at rated power 0.1% at 30 watts output	
IM Distortion:	0.3% at rated power 0.1% at 30 watts output	
Damping Factor:	35 at 8 ohms	
Frequency Response:	20 – 30,000Hz ±1dB	
RIAA Diviation:	20 – 20,000Hz ±0.8dB	
Sensitivity and Impedance:	Phono:	2.5mV/50 kohms
	CD:	150mV/50 kohms
	Tape Play:	150mV/50 kohms
	Tape Rec:	150mV/3.5 kohms
Phono Overload (MM):	120mV RMS at 1kHz, 0.3% THD.	
Signal-to-Noise Ratio:	Phono:	80dB (at 5 mV input, A weighted)
	CD/Tape:	100dB (IHF- A)
Tone controls:	Bass:	±10dB at 100Hz
	Treble:	±10dB at 10kHz
Muting	– ∞	

## TUNER SECTION

<b>FM:</b>	<b>–220V/240V/ Worldwide models–</b>	<b>–120V model–</b>
Tuning Range:	87.50 – 108.00MHz (50kHz steps) 87.50 – 108.00MHz (50kHz steps) or (100kHz steps) (Worldwide model)	87.5 – 108.0MHz (100kHz steps)
Usable Sensitivity:	Mono: 12.4dBf, 1.2μV, 75ohms 1.2μV (S/N 26dB, 40kHz Devi.) 75ohms DIN Stereo: 19.2dBf, 2.5μV, 75ohms 25μV (S/N 46dB, 40kHz Devi.) 75ohms DIN	Mono: 12.4dBf, 2.3μV  Stereo: 18.2dBf, 4.5μV
50dB Quieting Sensitivity:	Mono: 18.2dBf, 2.2μV, 75ohms Stereo: 38.2dBf, 22μV, 75ohms	Mono: 18.2dBf, 4.5μV Stereo: 38.2dBf, 45μV
Capture Ratio:	1.5dB	1.5dB
Image Rejection Ratio:	85dB	40dB
IF Rejection Ratio:	90dB	90dB
Signal-to-Noise Ratio:	Mono: 70dB Stereo: 65dB	Mono: 70dB Stereo: 65dB
Alternate Channel Attenuation:		55dB
Selectivity:	50dB DIN (±300kHz, 40kHz dev.)	
AM suppression Ratio:	50dB	50dB
Harmonic Distortion:	Mono: 0.15% Stereo: 0.30%	Mono: 0.15% Stereo: 0.30%
Frequency Response:	30 – 15,000Hz ±1.5dB	30 – 15,000Hz ±1.5dB
Stereo Separation:	40dB at 1kHz 30dB at 100 – 10,000Hz	40dB at 1kHz 30dB at 100 – 10,000Hz
Muting Level:	17.2dBf, 4μV	17.2dBf, 4μV
<b>AM:</b>		
Tuning Range:	522 – 1611kHz ( 9kHz steps) 522 – 1611kHz ( 9kHz steps) or 530 – 1710kHz (10kHz steps) (Worldwide model)	530 – 1710kHz (10kHz steps)
Usable Sensitivity:	30μV	30μV
Image Rejection Ratio:	40dB	40dB
IF Rejection Ratio:	40dB	40dB
Signal-to-Noise Ratio:	40dB	40dB
Harmonic Distortion:	0.8%	0.8%

## GENERAL

Dimensions (W × H × D):	435 × 115 × 320mm 17-1/8" × 4-1/2" × 12-9/16"
Weight:	6.7kg., 14.8lbs.

**REMOTE CONTROL TRANSMITTER RC-148S/RC-144S**

Transmitter: Infrared  
 Signal range: Approx. 5 meters (16ft.4")  
 Power supply: TWO "AA" batteries (1.5V × 2)

Specifications and features are subject to change without notice.

## SERVICE PROCEDURES

### 1.Replacing the fuses

For continued protection against fire hazard,replace only with same type and same rating fuse.

D (120V) model

Circuit no.	Part no.	Description
F901	252049	4A(ST-6),Primary

G (220V) and Q (240V) models

Circuit no.	Part no.	Description
F902	252074	2A-SE-EAK,Primary

W (Worldwide) model

Circuit no.	Part no.	Description
F901	252049	4A(ST-6),Primary
F902	252074	2A-SE-EAK,Primary

### 2.Safety-check out

(Only U.S.A. model)

After correcting the original service problem,perform the following safety check before releasing the set to the customer.

Connect the insulating-resistance tester between the plug of power supply cord and nickel screw on the back panel.

Specifications: 3.3Mohm ±10% at 500V.

### 3.Change of voltage

Worldwide models are equipped with a voltage selector to conform with local power supplies. This switch is located on the back panel. Be sure to set this switch to match the voltage of the power supply in your area before turning the power switch on.

This switch is set to 220V at the factory. Voltage is changed by sliding the groove in the switch with the screwdriver to the right or left. Confirm that the switch has been moved all the way to the right or left before turning the power switch on.

### 4.Step band selector switch

Worldwide models are equipped with a step band selector switch. This switch is located on the back panel. This switch is set to 50kHz (FM) and 9kHz (AM) at the factory, but may have to be reset to 100kHz and 10kHz depending on the area where the unit is used.

De-emphasis	FM step	AM step
Europe: 50μsec	50kHz	9kHz
U.S.A.: 75μsec	100kHz	10kHz

### 5.Changing the band step

With the exception of the models below, a BAND STEP selector switch is not provided.

(FM)

MODEL	BAND STEP	D713	R122
UD	100kHz→50kHz	Additional	27kΩ→27kΩ
UG/UQ	50kHz→100kHz	Eliminated	27kΩ→13kΩ

(AM)

BAND STEP	D712
10kHz→9kHz	Additional
9kHz→10kHz	Eliminated

In D712 ISS133 (Part No. 223163) is used. In D713 US1040 (Part No. 223150) is used. R101, with the muting amplitude determined, is on the back panel side of the tuner circuit printed circuit board assembly test points TP-1 and TP-2. (Refer page 13)

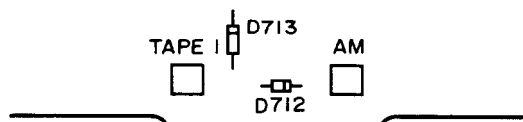

### 6.Memory preservation

This unit does not require memory preservation batteries. A built-in memory power back-up system preserves contents of the memory during power failures and even when the unit is unplugged. The unit must be plugged in and the power switch turned on and off once in order to charge the back-up system. Note that since this is not a permanent memory,the power switch must be turned on and off a few times each month to keep the back-up system operative. The period of time during which memory contents are preserved after power has last been turned off varies depending on climate and placement of the unit. On the average, memory contents are protected over a period of 3 to 4 weeks (a minimum of 2 weeks) after the last time power has been turned off. This period is shorter when the unit is exposed to very high humidity or used in an area with an extremely humid climate.

**EXPLODED VIEW**

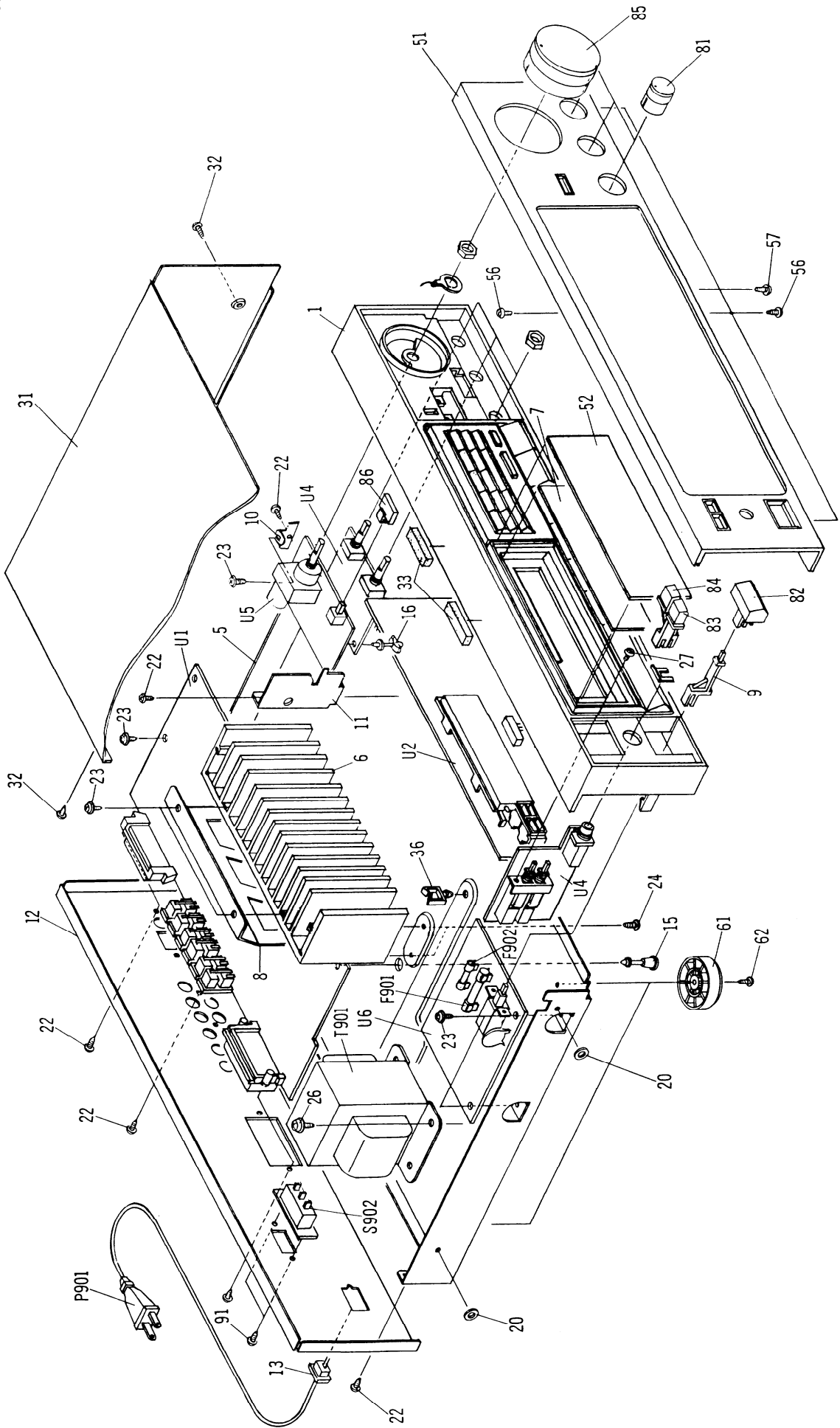

## PARTS LIST

REF. NO.	PART NO.	DESCRIPTION	REF. NO.	PART NO.	DESCRIPTION
1	27110540Y	Front bracket ass'y	S902	25065123	△ NSS-1258P, Voltage selector switch <W>
5	27100187BY	Chassis	T901	2300519Y	△ NPT-1060D, Power transformer <D>
6	27160210Y	Radiator		2300507Y	△ NPT-1028GM, Power transformer <G>
7	28133240Y	Back plate		2300508Y	△ NPT-1028DGM, Power transformer <W>
8	27130574Y	Bracket, IC		2300509Y	△ NPT-1028QM, Power transformer <QA/QB>
9	27273116Y	Joint, POWER	U1	1A203558-3	NAAR-3558-3, Main circuit pc board ass'y <D>
10	27141330Y	Bracket, PC		1A203558-3A	NAAR-3558-3A, Main circuit pc board ass'y <G/QA/QB>
11	27130577Y	Bracket, SHIELD		1A203558-3B	NAAR-3558-3B, Main circuit pc board ass'y <W>
12	27121316Y	Back panel <D>	U2	1A203559-3	NADIS-3559-3, Display circuit pc board ass'y <D>
	27121316-1Y	Back panel <G>		1A203559-3A	NADIS-3559-3A, Display circuit pc board ass'y <D>
	27121316-3Y	Back panel <W>		1A203559-3B	NADIS-3559-3B, Display circuit pc board ass'y <W>
	27121264-4Y	Back panel <QA/QB>	U3	1A203560-3	NAAF-3560-3, Tone circuit pc board ass'y <D>
13	27300750	△ Bushing(Strainrelief)		1A203560-3A	NAAF-3560-3A, Tone circuit pc board ass'y <D>
15	27190524	KGLS-14R, Holder	U4	1A203561-3	NASW-3561-3, Speaker switch pc board ass'y <G/W/QA/QB>
16	27190503	KGLS-8R, Holder		1A203561-3A	NASW-3561-3A, Speaker switch pc board ass'y <D>
17	27270148	Spacer	U5	1A203562-3	NAETC-3562-3, Volume circuit pc board ass'y
18	28141058	14×50×25, Cushion	U6	1A203563-3	NAPS-3563-3, Power supply circuit pc board ass'y <D>
20	27270212	Spacer		1A203563-3A	NAPS-3563-3A, Power supply circuit pc board ass'y <G/QA/QB>
22	834430088	3TTS+8B(BC), Tapping screw		1A203563-3B	NAPS-3563-3B, Power supply circuit pc board ass'y <G>
23	831130088	3TTW+8B, Tapping screw			
26	830440089	4TTC+8C(BC), Tapping screw			
27	82143006	3P+6FN(BC), Pan head screw			
31	28184432Y	Top cover			
32	834430088	3TTS+8B(BC), Tapping screw			
33	28140020Y	Cushion			
36	27300833	Clamp			
51	1A203121	Front panel ass'y			
52	28191504Y	Clear plate			
56	833430080	3TTP+8P(BC), Tapping screw			
57	834430088	3TTS+8B(BC), Tapping screw			
61	27175219CY	Leg			
62	834430088	3TTS+8B(BC), Tapping screw			
81	28323310AY	Knob, TONE			
82	28323241-1AY	Knob, POWER			
83	28323314Y	Knob, SPEAKER A			
84	28323316Y	Knob, SPEAKER B			
85	28323689	Knob, VOLUME			
86	28323638Y	Knob, LOUDNESS			
91	82143006	3P+6F(BC), Pan head screw <W>			
F901	252049	△ 4A(ST-6), Fuse, primary <D/W>			
F902	252074	△ 2A(SE-EAK), Fuse, primary <G/W/QA/QB>			
P901	253163	△ AS-UC-6#18, Power supply cord <D>			
	253164	△ AS-CEE, Power supply cord <G/W>			
	253118	△ AS-SAA, Power supply cord <QA>			
	2300413	△ Power supply cord <QB>			

NOTE: <D> : Only 120V model  
 <G> : Only 220V model  
 <W> : Only Worldwide model  
 <QA> : Only Australian model  
 <QB> : Only U.K. model

NOTE: THE COMPONENTS IDENTIFIED BY MARK △ ARE CRITICAL FOR RISK OF FIRE AND ELECTRIC SHOCK. REPLACE ONLY WITH PART NUMBER SPECIFIED.

# IC BLOCK DIAGRAM AND DESCRIPTIONS

Q705

LC6538D-3984 (Micro processor)

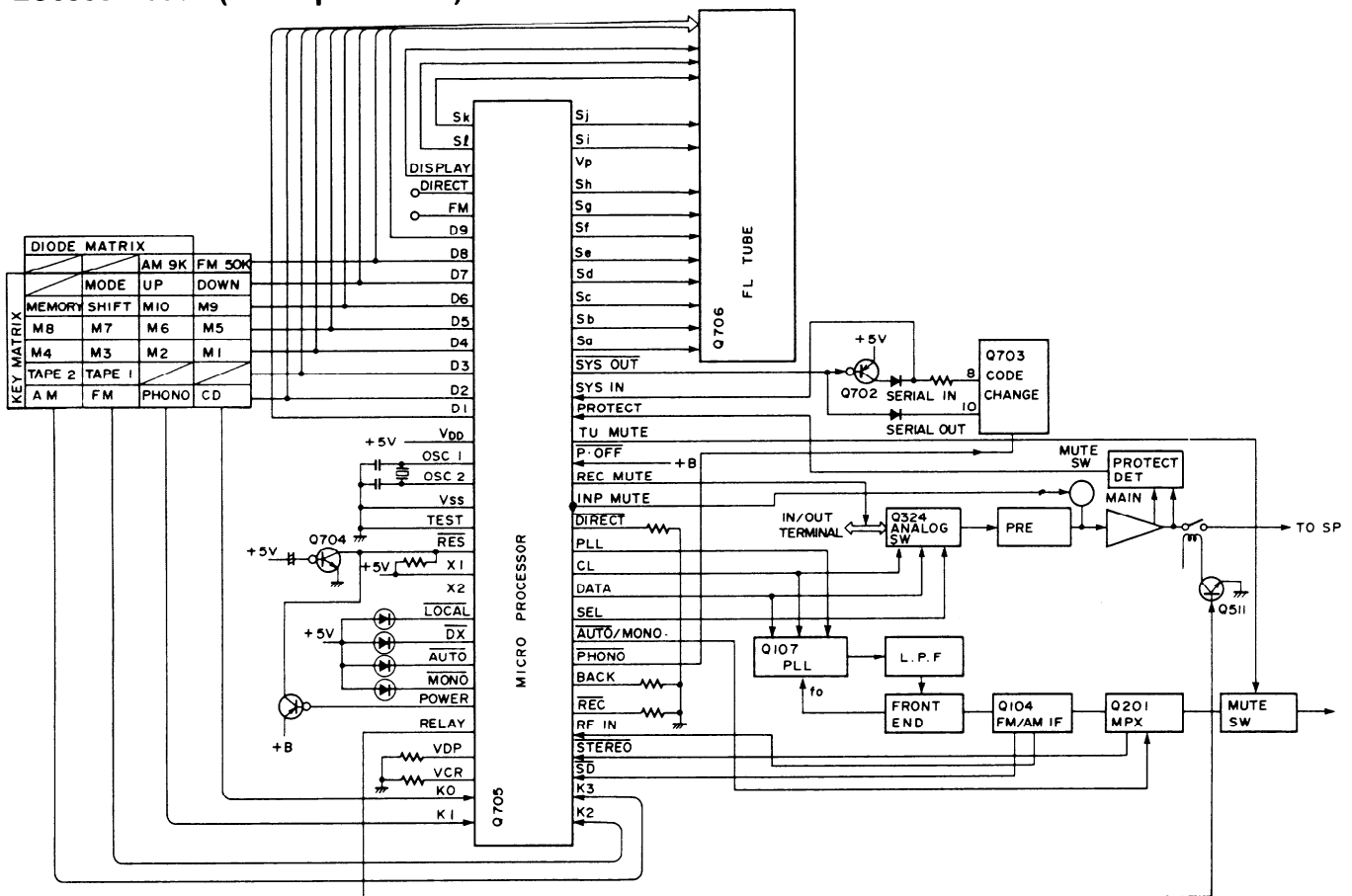

Pin No.	Terminal	Descriptions
1	Sk	These are the output terminal for segment signal. "H" when active.
2	Sl	
3	DISPLAY	This is the display control output terminal. "H" during FL tube lights on.
4	DIRECT	This is the direct indicator output terminal. Not used.
5	FM	This is FM control output terminal. Not used.
6	D9	These are the output terminal for digit and key scan signal. "H" when active.
7	D8	
8	D7	
9	D6	
10	D5	
11	D4	
12	D3	
13	D2	
14	D1	
15	V <sub>DD</sub>	This is the device power source terminal. At the time of operation, the supply is 5V. The internal data memory (RAM) is maintained by means of the super capacitor.
16	OSC1	This is the main system clock connection terminal. Connect to the 4.00MHz ceramic oscillator.
17	OSC2	
18	V <sub>SS</sub>	Ground terminal.
19	TEST	This is the test terminal for LSI. Connect to the ground terminal.
20	RES	This is the reset terminal. Reset at the low level when the power is turned on.
21	X1	These are the sub clock input terminal. Not used.
22	X2	
23	LOCAL	These are the auto reception mode indicator output terminal. "L" when active.
24	DX	
25	AUTO	
26	MONO	

Pin No.	Terminal	Descriptions
27	POWER	This is the power control output terminal. "H" when the power is turned on.
28	RELAY	This is the speaker protection relay control output terminal. "H" when active.
29 30	VDP VCR	These are the video signal control output terminal. Not used.
31 32 33 34	K0 K1 K2 K3	These are the key return signal input terminal. "H" when active.
35	SD	This is the auto stop input terminal. Auto tuning stops when this terminal becomes low level.
36	STEREO	This is the input terminal for detection of the stereo broadcast. "L" when stereo broadcast.
37	RF IN	This is IF signal level input terminal. DX mode when this terminal becomes the high level.
38 39	REC BACK	These are the mode setting input terminals.
40	PHONO	This is PHONO control output terminal. "L" when selector switch is PHONO.
41	AUTO/MONO	This is AUTO/MONO switching output terminal. "L" when AUTO.
42	SEL	Connect to terminal SEL of analog switch. (Q324 LC7821)
43	DATA	This is the serial data output terminal. Connect to terminal DATA of PLL IC (Q107 LM7001) and terminal DI of analog switch.
44	CLOCK	This is the serial clock output terminal. Connect to terminal CI of PLL IC and terminal DI of analog switch.
45	PLL	Connect to terminal CE of PLL IC.
46	DIRECT	This is the direct control output terminal. "L" when active.
47	INP MUTE	This is the muting output terminal for audio amplifier. "H" when the selector switch is operated.
48	REC MUTE	This is the muting output terminal for recording. "H" when the selector switch is operated.
49	P. OFF	This is the input terminal for detection of stoppage of electric current. "L" when the stoppage of electric current.
50	TU MUTE	This is the muting output terminal of tuner section. "H" when active.
51	PROTECT	This is the detection terminal for protection circuit. The speaker relay turns off when this terminal becomes the high level.
52	SYS IN	This is the system code input terminal. "H" when active.
53	SYS OUT	This is the system code output terminal. "L" when active.
54 55 56 57 58 59 60 61	Sa Sb Sc Sd Se Sf Sg Sh	These are the segment output terminal. "H" when active.
62	VP	This is the power supply terminal for pull-down resistor.
63 64	Si Sj	These are the segment output terminal. "H" when active.

### Key and diode matrix

	D1(14)	D2(13)	D3(12)	D4(11)	D5(10)	D6( 9)	D7( 8)	D8( 7)	D9( 6)
K3(34)		AM	TAPE-2	M4	M8	MEMORY	DIRECT	PSET30	
K2(33)		FM	TAPE-1	M3	M7	SHIFT	FM MODE	EU1/2	
K1(32)		PHONO	VCR	M2	M6	M10	UP	AM9K	VKEY
K0(31)	POWER	CD	VDP	M1	M5	M9	DOWN	FM50K	PKEY
									DIODE MATRIX

**FM50K (FM band setting)**

FM50K	Region	Frequency range	Channel space	Reference frequency	IF frequency
1	Europe	87.50 ~ 108.00MHz	50kHz	25kHz	10.7MHz
0	U.S.A.	87.5 ~ 108.0MHz	100kHz	25kHz	10.7MHz

**AM9K (AM band setting)**

AM9K	Region	Frequency range	Channel space	Reference frequency	IF frequency
1	Europe	522 ~ 1611 kHz	9kHz	9kHz	450kHz
0	U.S.A.	530 ~ 1710 kHz	10kHz	10kHz	450kHz

**Q706**

**FIP9BDM8 (FL tube)**

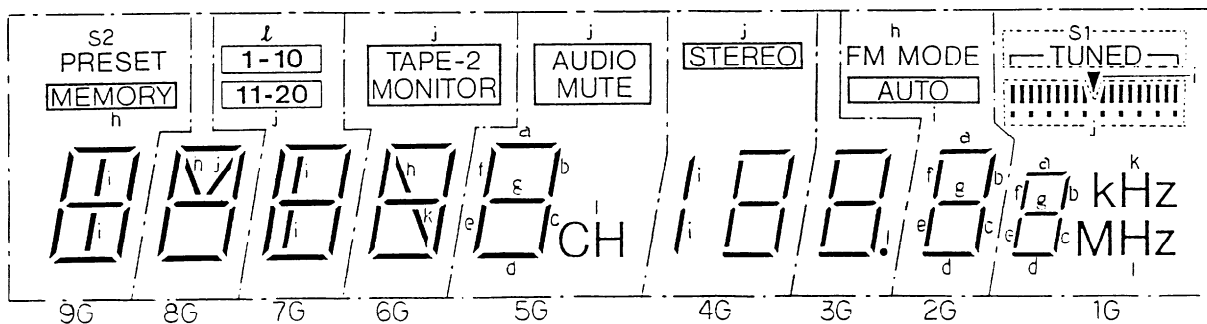

**Terminal connection**

TERMINAL NO. ELECTRODE	1 F	2 F	3 NP	4 P (j)	5 9G	6 P (i)	7 8G	8 P (h)	9 P (g)	10 7G	11 P (f)	12 NP	13 6G	14 P (e)	15 P (d)	16 P (c)	17 5G	18 P (b)		
TERMINAL NO. ELECTRODE			19 P (a)	20 NP	21 4G	22 P (k)	23 P (l)	24 NP	25 3G	26 P (s2)	27 2G	28 P (s1)	29 1G	30 NP	31 NP	32 NP	33 1G	34 NP	35 F	36 F

Notes F: Filament NP: No Pin  
G: Grid P: Anode

**Connection of fluorescent tube and microprocessor**

	D9 (6)	D8 (7)	D7 (8)	D6 (9)	D5 (10)	D4 (11)	D3 (12)	D2 (13)	D1 (14)
Sa (54)	a	a	a	a	a	a	a	a	a
Sb (55)	b	b	b	b	b	b	b	b	b
Sc (56)	c	c	c	c	c	c	c	c	c
Sd (57)	d	d	d	d	d	d	d	d	d
Se (58)	e	e	e	e	e	e	e	e	e
Sf (59)	f	f	f	f	f	f	f	f	f
Sg (60)	g	g	g	g	g	g	g	g	g
Sh (61)	MEMORY	h	h	h				FM MODE	
Si (63)	i	i	i		/	/		AUTO	▼
Sj (64)	j	j	11-20	TAPE-2	MUTING	STEREO		MONO	
Sk (1)			k	k	k				kHz
Sl (2)	l		l-10		CH				MHz

( ): Pin number of micro processor



**Q107**  
**LM7001 (PLL synthesizer and controller)**

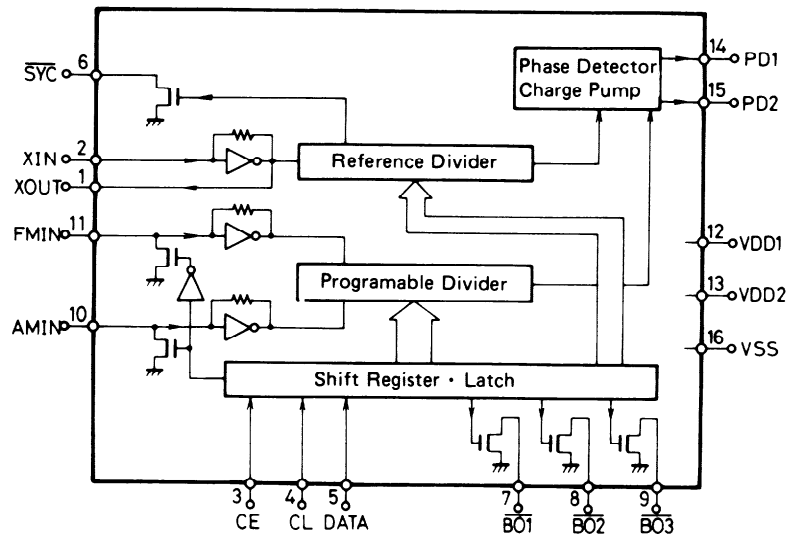

Pin No.	Terminal	Description
1	XOUT	Connect to the 7.2 MHz crystal oscillator.
2	XIN	
3	CE	Chip enable terminal. Connect to the PLL terminal of micro processor.
4	CL	Serial clock input terminal. Connect to the CLOCK terminal of micro processor.
5	DATA	Serial data input terminal. Connect to the DATA terminal of micro processor.
6	$\overline{\text{SYN}}$	Not used.
7	$\overline{\text{BO1}}$	Not used.
8	$\overline{\text{BO2}}$	FM control signal output terminal. "L" when FM.
9	$\overline{\text{BO3}}$	AM control signal output terminal. "L" when AM.
10	AMIN	AM local oscillator input terminal.
11	FMIN	FM local oscillator terminal.
12	VDD 1	Power supply terminal for back-up.
13	VDD 2	Power supply terminal.
14	PD1	Charge pump output of the phase detector which constitutes the PLL. High level is output when the divided local oscillator frequency is high than the reference frequency. In the opposite case, low level is output. Floating occurs when the frequencies matched. The output is applied to the variable capacitor diode in the local oscillator through the low pass filters.
15	PD2	
16	Vss	Ground terminal.

**Q324**  
**LC7821 (Analog switch)**

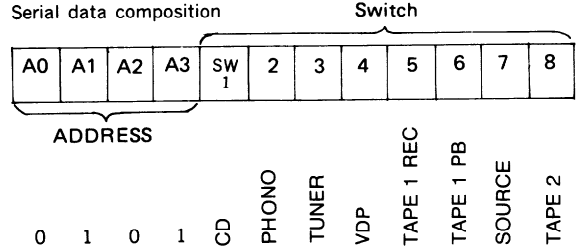
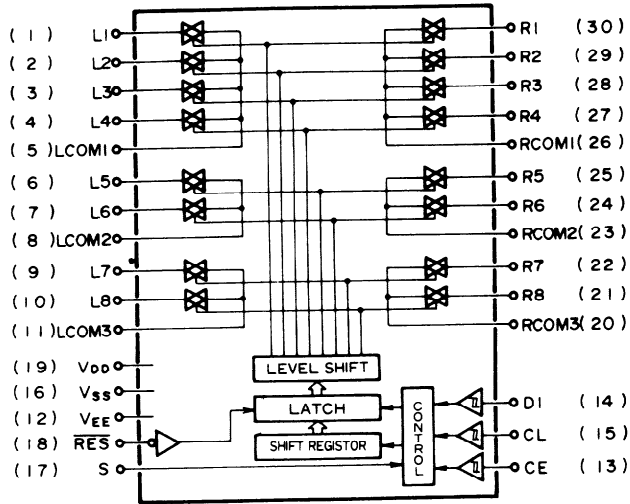

The source becomes ON when the bit of switch becomes the high level.

(Q312)

Pin No.	Terminal	Description	Pin No.	Terminal	Description
1	CD	Input/output terminals of audio signal of right channel. Control to the inside analog switch at the serial data.	16	VSS	Ground terminal.
2	PHONO		17	S	Selector terminal.
3	TUNER		18	RES	Reset terminal. When power is turned ON, the condition of the analog switch is not determined, but when this terminal is "L", all analog switches are OFF.
4	L COM 1		19	VDD	Power supply terminal. (+15V)
5	VDP		20	R COM 3	Input/output terminals of audio signal of left channel. Control to the inside analog switch at the serial data.
6	VCR PLAY		21	TAPE 1 PLAY	
7	L COM 2		22	R COM 2	
8	TAPE 1 PLAY		23	VCR PLAY	
9	L COM 3		24	VDP	
10			25	R COM 1	
11			26	TUNER	
12	VEE	27	PHONO		
13	CE	28	CD		
14	DI	29			
15	CL	30			

**Q301, Q401, Q402**  
**NJM4558D-X (Operation amplifier)**

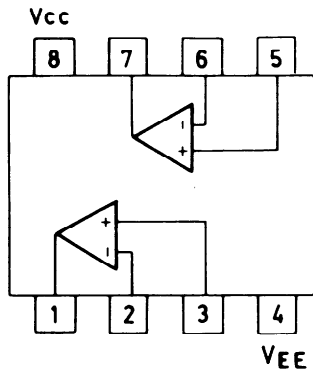

**Q501**  
**STK4171V / STK4151V (Power amplifier IC)**

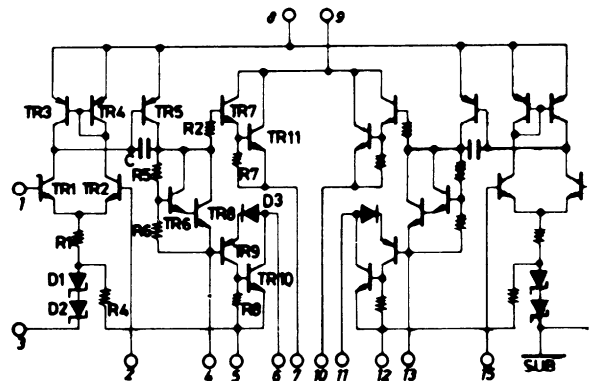

**Q104**  
**LA1266 (FM IF & AM radio system)**

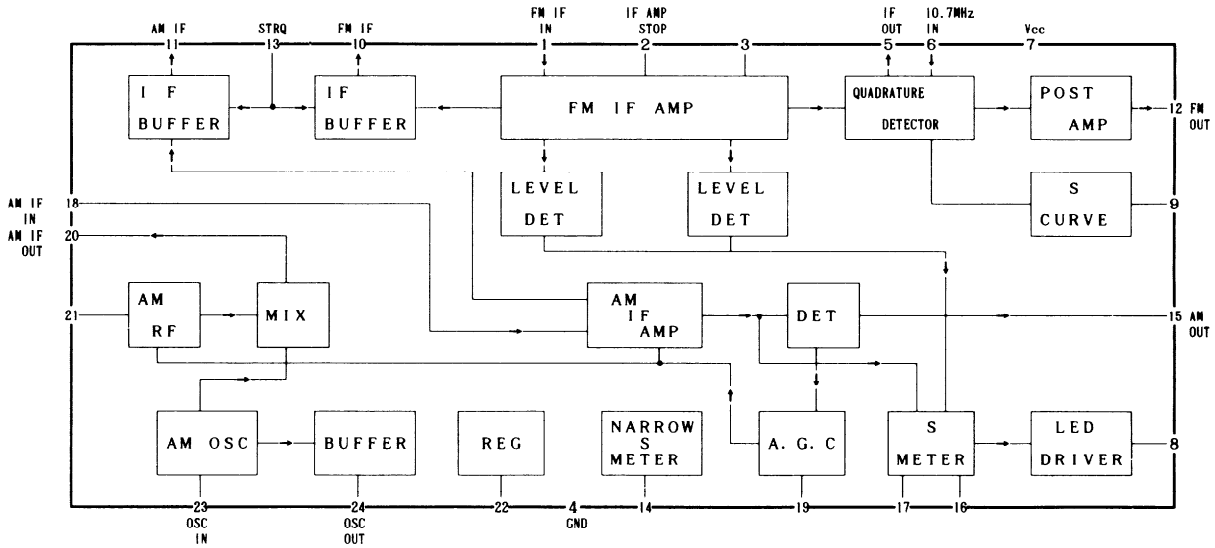

**Q201**  
**AN7470 (Stereo decoder)**

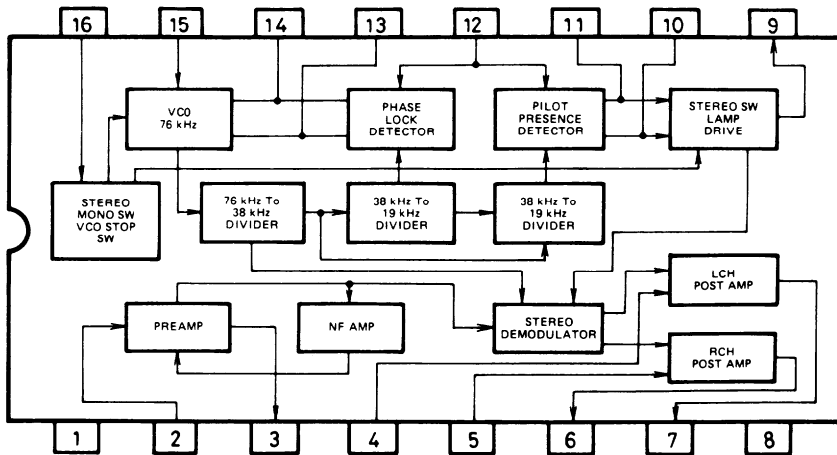

**Q403**  
**LB1630 (Motor driver)**

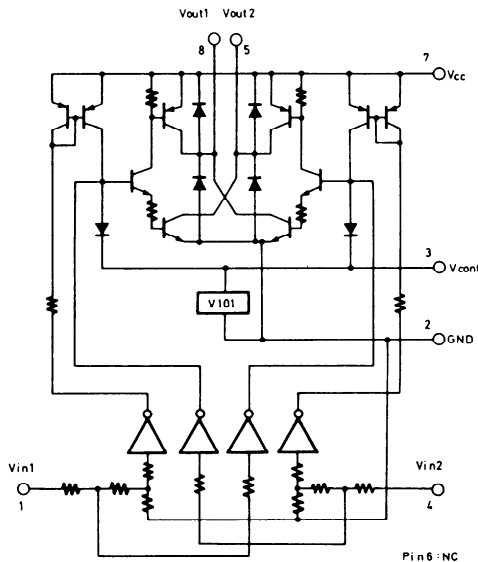

TRUTH TABLE

IN 1	IN 2	OUT 1	OUT 2	MOTOR
H	L	H	L	Normal
L	H	L	H	Reverse
H	H	OFF	OFF	Wait
L	L	OFF	OFF	Wait

**Q703**  
**LC6527C-3987 (Remote controller)**

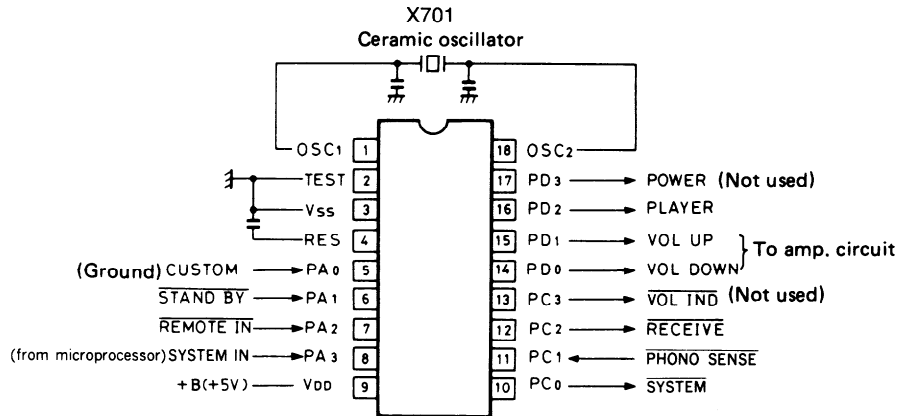
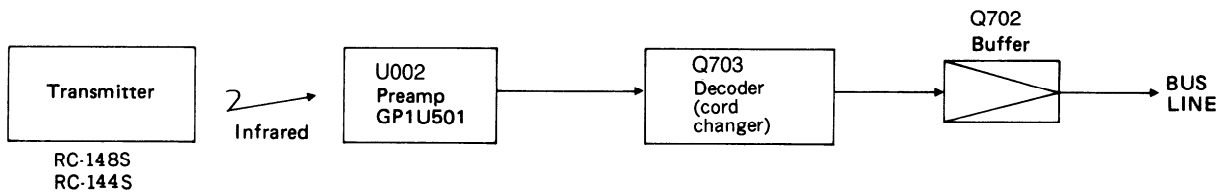

Connection diagram

Terminal No.	Symbol	Terminal	Description
1 18	OSC1 OSC2	OSC	Connect to the 4MHz ceramic oscillator.
2	TEST	TEST	Test terminal. Connect to the ground.
3	V <sub>SS</sub>	GND	Ground terminal.
4	RES	RES	Reset terminal.
5	PA0	CUSTOM	The custom code for decode is selected at this terminal. For this model, the level is low.
6	PA1	STANDBY	Terminal for STANDBY detection. During low input, only the POWER code is decoded.
7	PA2	REMOTE IN	Signal input terminal from remote control preamp. Active low.
8	PA3	SYSTEM IN	System code input terminal. Active high.
9	V <sub>DD</sub>	+B(5V)	Power supply terminal.
10	PC0	SYSTEM OUT	Output at this terminal are the custom code remote control code input to REMOTE IN, the system code that has been converted corresponding to the decoded data code.
11	PC1	PH SENS	Phono detection input terminal. Active low.
12	PC2	RECEIVE	This is the display output for remote control reception. Output is low when decoded code is being received.
13	PC3	VOLIND	During output of VOLUME UP/DOWN, a pulse ( $\sqrt{T} \text{ } \overline{\text{I}} \text{ } \overline{\text{T}}$ ; T=250ms) is output.
14	PD0	VOL DOWN	When the volume DOWN code is input, a high pulse of 120ms is output.
15	PD1	VOL UP	When the volume UP code is input, a high pulse of 120ms is output.
16	PD2	PLAYER	Player control output terminal.
17	PD3	POWER	The power code input inverts the L/H. Level is high for power being tuned ON.

# ADJUSTMENT PROCEDURES

## FM section

Item	Step	AM SG output	Connection of instrument	FM SG output	Stereo modulator output	Tuned frequency	Output indicator	Adjustment point	Adjust for	Remarks
I F	1	—	Fig. 1	99.1MHz 1kHz/75kHz devi. 55dB(60dB)	—	99.1MHz	DC voltmeter	L:01	0 ± 20mV	Set the FM mode switch to MONO. Repeat the steps 1 and 2 until no further adjustment is necessary.
	2	Distortion analyzer								
V C O	1	—	Fig. 2	99.1MHz 1kHz/75kHz devi. 55dB(60dB)	—	99.1MHz	Frequency counter	R201	19kHz ± 10Hz	Set the FM mode switch to AUTO.
Stereo distortion	2	Distortion analyzer								
Stereo separation	1	—	Fig.3	99.1MHz Ext. modulation 55dB(60dB)	Lch. 1kHz	99.1MHz	Rch. AC voltmeter	R202	Minimum	Maximum and same separation
	2	Ext. modulation 55dB(60dB)								
Tuned indicator level	1	—	Fig. 3	99.1MHz 1kHz, 75kHz devi. 19.2dB(14dB)(20V model) 12dB (other models)	—	99.1MHz	TUNED indicator	R101	Light on	
	2	—								

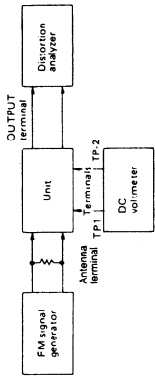

(Fig. 1)

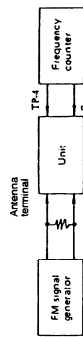

Use the high impedance probe. (10:1)

(Fig. 2)

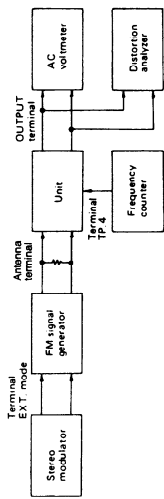

(Fig. 3)

## AM section

Step	AM SG output	Tuned Frequency	Output indicator	Adjustment point	Adjust for
1	—	522kHz (530kHz) (531kHz)	Digital DC voltmeter	OSC coil on RF block (L151)	1.5V ± 0.1V
2	603kHz/30dB/m (600kHz) 400Hz 30% mod.	603kHz (600kHz)	A C voltmeter	RF coil on RF block (L151)	Maximum
3	990kHz, 60dB/m 400Hz 30% mod.	990kHz	A C voltmeter	L152	Maximum

Note: ( ) :120V model (10kHz step)  
< > :Worldwide model

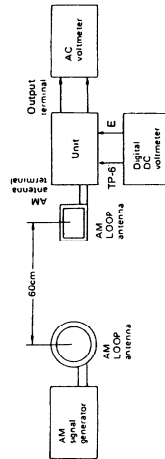

## Reference specifications

Tuned voltage AM 530kHz (U.S.A. model) 1.5 ± 0.4V  
522kHz (European model) 1.5 ± 0.4V  
1710kHz (U.S.A. model) 8.0 ± 0.5V  
1611kHz (Europe in model) 7.5 ± 0.5V  
87.9MHz (U.S.A. model) 2.0 ± 0.5V  
87.50MHz (European model) 2.0 ± 0.5V  
108.0MHz (U.S.A. model) 7.5 ± 0.5V  
108.0MHz (European model) 7.5 ± 0.5V

DC voltmeter to test point TP-6

Muting width (U.S.A. model) 65 ± 15kHz  
(European model) 35 ± 10kHz

Muting level (U.S.A. model) FM 14 ± 13dB  
(European model) FM 12 ± 3dB

Auto stop level AM Less than 72dB/m  
FM Less than 20dB $\mu$

Stereo indicator level 14 ± 4dB $\mu$

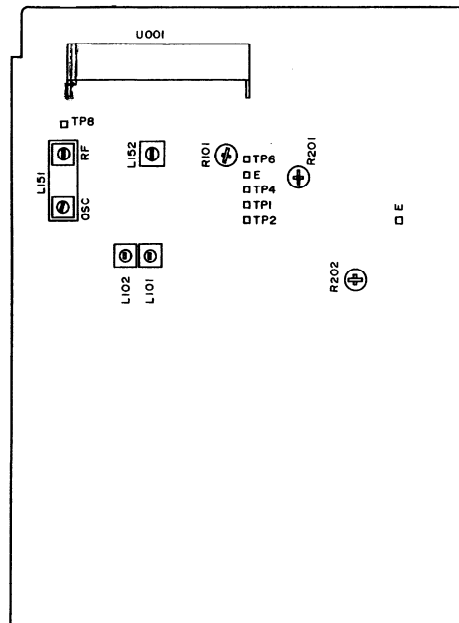

Adjustment point.

1 2 3 4 5 6 7

SCHEMATIC DIAGRAM

— 120V MODEL —

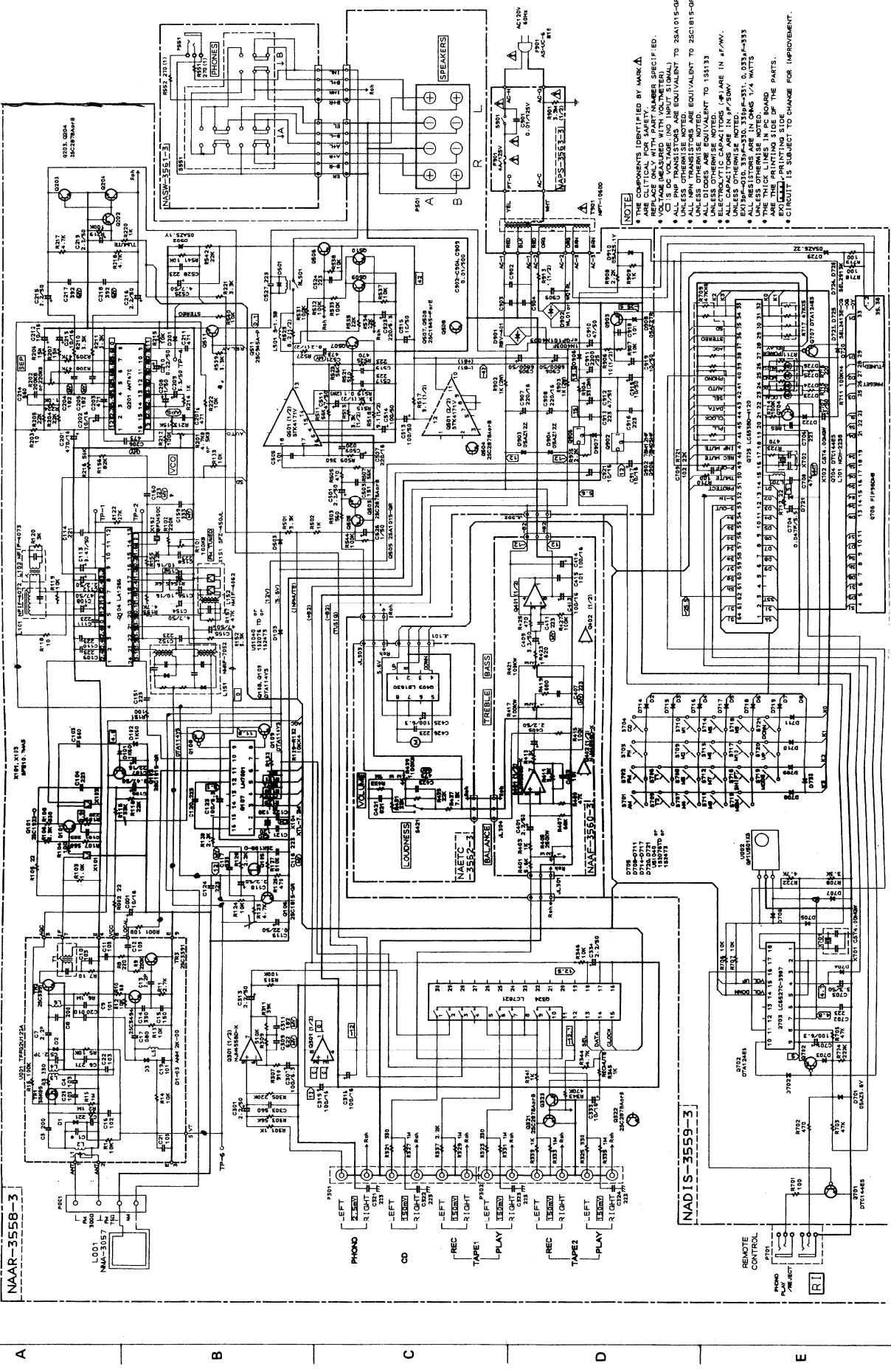

**NOTE**

- THE COMPONENTS IDENTIFIED BY MARK  $\Delta$  ARE AVAILABLE FROM ONKYO CORPORATION. REPLACE ONLY WITH PART NUMBER SPECIFIED.
- VOLTAGE MEASURED WITH VOLTMETER.
- ALL PNP TRANSISTORS ARE EQUIVALENT TO 2SA1015-QR.
- ALL NPN TRANSISTORS ARE EQUIVALENT TO 2SC1815-QR.
- UNLESS OTHERWISE NOTED, CAPACITORS ARE IN P.F.M.V.
- UNLESS OTHERWISE NOTED, RESISTORS ARE IN  $\Omega$ .
- ELECTROLYTIC CAPACITORS ( $\Phi$ ) ARE IN  $\mu$ F/V.
- EXCEPT FOR THE PARTS IDENTIFIED BY MARK  $\Delta$ , ALL OTHER PARTS ARE IN THE PRINTING SIDE OF THE PARTS.
- CIRCUIT IS SUBJECT TO CHANGE FOR IMPROVEMENT.

# PRINTED CIRCUIT BOARD PARTS LIST

## MAIN CIRCUIT PC BOARD (NAAR-3558-3/3A/3B)

CIRCUIT NO.	PART NO.	DESCRIPTION	CIRCUIT NO.	PART NO.	DESCRIPTION
	<b>Front end</b>			<b>Ceramic filters</b>	
U001	240084	TFFG2U122A <D>	X101, X103	3010071	SFE10.7MA5 <D>
	240085	TFFG4E122A <G/W>	X101	3010070	SFE10.7MS3GYA <G/W>
			X102	3010137	SFE10.7MMK <G/W>
	<b>ICs</b>		X151	3010123	SFZ450JL
Q104	22240039	LA1266	X152	3010076	BFU450C
Q107	22240090	LM7001			
Q201	22240242	AN7470		<b>X'tal</b>	
Q301	222502	NJM4558D-X	X104	3010158Y	XTL-7.2M
Q324	22240079	LC7821		<b>Capacitors</b>	
Q501	222083Y	STK4171V <D>	C001	354741009	10 $\mu$ F, 16V, Elect.
	222044	STK4151V <G/W>	C106	354784799	0.47 $\mu$ F, 50V, Elect.
Q902	222780125	78M12HF	C107	354742209	22 $\mu$ F, 16V, Elect.
Q906	222780055	78M05HF	C108	354784709	47 $\mu$ F, 50V, Elect.
	<b>Transistors</b>		C112	354780229	2.2 $\mu$ F, 50V, Elect.
Q101	2211723	2SC1923-O	C113	354784799	0.47 $\mu$ F, 50V, Elect.
Q102	2210746	2SC945A-P <G/W>	C116	371122234	0.022 $\mu$ F $\pm$ 5%, 50V, Mylar
Q103	2211255	2SC1815-GR	C117	371123334	0.033 $\mu$ F $\pm$ 5%, 50V, Mylar
Q105	2212294	2SK108-D	C118	354780229	2.2 $\mu$ F, 50V, Elect.
Q106	2211255	2SC1815-GR	C119	354782299	0.22 $\mu$ F, 50V, Elect.
Q108, Q109	2213090	DTA114YS	C123	354721019	100 $\mu$ F, 6.3V, Elect.
Q202, Q323	2211455	2SA1015-GR	C154	354780479	4.7 $\mu$ F, 50V, Elect.
Q203, Q204	2212285 or	2SC2878-A or	C155	354784709	47 $\mu$ F, 50V, Elect.
Q321, Q322	2212286	2SC2878-B	C156, C157	354741009	10 $\mu$ F, 16V, Elect.
Q503, Q504	2212285 or	2SC2878-A or	C159	371123334	0.033 $\mu$ F $\pm$ 5%, 50V, Mylar
	2212286	2SC2878-B	C160	371122234	0.022 $\mu$ F $\pm$ 5%, 50V, Mylar
Q505, Q506	2211455	2SA1015-GR	C201	354744719	470 $\mu$ F, 16V, Elect.
Q507, Q508	2211732 or	2SC1845-F or	C202	354741009	10 $\mu$ F, 16V, Elect.
	2211733	2SC1845-E	C204, C205	371121824	1800 pF $\pm$ 5%, 50V, Mylar <D>
Q509, Q510	2211255	2SC1815-GR		371121224	1200 pF $\pm$ 5%, 50V, Mylar <G>
Q511	2210746	2SC945A-P		371121524	1500 pF $\pm$ 5%, 50V, Mylar <W>
Q903	2211455	2SA1015-GR	C206	371124734	0.047 $\mu$ F $\pm$ 5%, 50V, Mylar
	<b>Diodes</b>		C207	370134714	470pF $\pm$ 5%, 100V, APS
D101, D102	223132	1K60	C208	354780109	1 $\mu$ F, 50V, Elect.
D103	223150,	US1040,	C209	354780339	3.3 $\mu$ F, 50V, Elect.
	223145 or	1S2076TD or	C210	354782299	0.22 $\mu$ F, 50V, Elect.
	223124	1S2473	C212, C213	354741009	10 $\mu$ F, 16V, Elect.
D201, D501	223163	1SS133	C215, C216	354780229	2.2 $\mu$ F, 50V, Elect.
D502	224150512	05AZ5.1Y	C217, C218	371123924	3900pF $\pm$ 5%, 50V, Mylar
D503	223163	1SS133	C219	354780229	2.2 $\mu$ F, 50V, Elect.
D901	22380023	RBV401	C301, C302	354780229	2.2 $\mu$ F, 50V, Elect.
D902	223862 or	WL01 or	C307, C308	354721019	100 $\mu$ F, 6.3V, Elect.
	223890	W01RL	C309, C310	371126224	6200pF $\pm$ 5%, 50V, Mylar
D903, D904	224151203	05AZ12Z	C311, C312	371121824	1800pF $\pm$ 5%, 50V, Mylar
D906	223880 or	GP101N4003 or	C313, C314	354780229	2.2 $\mu$ F, 50V, Elect.
	223896	1N4003F	C315, C316	354741019	100 $\mu$ F, 16V, Elect.
D907	223163	1SS133	C333	354741009	10 $\mu$ F, 16V, Elect.
D908	224152704	05AZ27R	C334	354780229	2.2 $\mu$ F, 50V, Elect.
D910	224150512	05AZ5.1Y	C501, C502	354780229	2.2 $\mu$ F, 50V, Elect.
	<b>Transformers</b>		C507, C508	354742219	220 $\mu$ F, 16V, Elect.
L101	233401	NFIF-4072	C511, C512	354784709	47 $\mu$ F, 50V, Elect.
L102	233402	NFIF-4073	C513, C514	354781019	100 $\mu$ F, 50V, Elect.
L152	232139	NMIF-4062	C515	354781009	10 $\mu$ F, 50V, Elect.
	<b>Coils</b>		C521, C522	371124734	0.047 $\mu$ F $\pm$ 5%, 50V, Mylar
L103	233383	NMC-6070 <G/W>	C523	354722219	220 $\mu$ F, 6.3V, Elect.
L201, L202	233294	NMC-5040 <G/W>	C525	354780479	4.7 $\mu$ F, 50V, Elect.
L501, L502	231001	S-1.3B	C526	354780109	1 $\mu$ F, 50V, Elect.
	<b>RF block</b>		C905, C906	3504207	6800 $\mu$ F, 50V, Elect.
L151	232152	NMRF-7052	C907, C908	354742219	220 $\mu$ F, 16V, Elect.
			C910, C912	354784709	47 $\mu$ F, 50V, Elect.
			C911	354752229	2200 $\mu$ F, 25V, Elect.
			C915, C919	354781009	10 $\mu$ F, 50V, Elect.
			C917, C921	354741009	10 $\mu$ F, 16V, Elect.
				<b>Resistors</b>	
			R101	5210070 or	N06HR 100KBD
				5210221	Semi-fixed

CIRCUIT NO.	PART NO.	DESCRIPTION	CIRCUIT NO.	PART NO.	DESCRIPTION
R201	5210062 or 5210216	N06HR4.7KBD or N06HR5KBD, Semi-fixed	X701, X702	3010150	CST4.00MGW
R202	5210072 or 5210222	N06HR220KBD or N06HR200KBD, Semi-fixed	L701	233400K220 or 233409K220	NCH-2238 or NCH-1284
R513-R516	442523324	3.3kohm, 1/2W, Metal oxide film	C701	354721019	100 $\mu$ F, 6.3V, Elect.
R517, R518	442520914	9.1ohm, 1/2W, Metal oxide film	C703	354780339	3.3 $\mu$ F, 50V, Elect.
R519, R520	4500001	BPR2FK-0.1, Metal plate	C704	3000051	0.047F, 5.5V, Super
R527-R530	442520824	8.2ohm, 1/2W, Metal oxide film	C707	353780109	1 $\mu$ F, 50V, Elect.
R902, R903	441721024 441729114	1kohm, 2W, Metal oxide film <D> 910ohm, 2W, Metal oxide film <G/W>	C708	375524744	0.47 $\mu$ F $\pm$ 5%, 50V, Plastic (MMT)
R904	441723304	33ohm, 2W, Metal oxide film	R709	49163473406	47kohm $\times$ 6, 1/10W, Network
R906	442521004	10ohm, 1/2W, Metal oxide film	R711	49163104404	100kohm $\times$ 4, 1/10W, Network
R913	442520104	1ohm, 1/2W, Metal oxide film	R717	49163473404	47kohm $\times$ 4, 1/10W, Network
	<b>Terminals</b>			<b>Switches</b>	
P001	25060085 25060087	NTM-4PDMN29, Antenna <D> NTM-2PDMN31, Antenna <G/W>	S701-S721	25035548	NPS-111-S510
P501	25060093	NTM-8PDMN34, Speaker	S722	25065286	NSS-22112, Slide, band <W>
P301	25045252	NPJ-6PDBL124		<b>Holder</b>	
P302	25045213	NPJ-6PDBL92		27190700	L.E.D
	<b>Jack</b>				
P701	25045172	HSJ1003-01-020			
	<b>Relay</b>				
RL501	25065339	NRL-2P5A-DC24-046			

#### DISPLAY CIRCUIT PC BOARD (NADIS-3559-3/3A/3B)

CIRCUIT NO.	PART NO.	DESCRIPTION
	<b>Remote control sensor</b>	
U002	24130003	GP1U501XS
	<b>ICs</b>	
Q703	22240243	LC6527C-3987
Q705	22240319	LC6538D-4297
	<b>Transistors</b>	
Q701	221282	DTC144ES <D>
Q702, Q707	2212600	DTA124ES
Q704	221282	DTC144ES
	<b>FL tube</b>	
Q706	212075	FIP9BDM8
	<b>Diodes</b>	
D701	224150562 or 224450562	05AZ5.6Y or MTZ5.6B
D702-D704	223163	1S5133
D705	223150,	US1040,
D708-D711	223145 or	1S2076TD or
D714-D717	223124	1S2473
D712	223163	1S5133 <G>
D713	223150,	US1040,
	223145 or	1S2076TD or
	223124	1S2473 <G>
D706, D707	223163	1S5133
D718-D720	223163	1S5133
D721	223150,	US1040,
	223145 or	1S2076TD or
	223124	1S2473
D722, D733	223163	1S5133
D729	224150623	05AZ6.2Z
D730, D732	223163	1S5133 <W>
D731	223150,	US1040,
	223145 or	1S2076TD or
	223124	1S2473 <W>
	<b>L.E.Ds</b>	
D723, D725	225137CG, 225137DG or 225137DY	SEL2413E-CG, SEL2413E-DG or SEL2413E-DY
D724, D726	225142	SEL2913K

#### TONE CIRCUIT PC BOARD (NAAF-3560-3/3A)

CIRCUIT NO.	PART NO.	DESCRIPTION
	<b>ICs</b>	
Q401, Q402	222502	NJM4558D-X
	<b>Capacitors</b>	
C401, C402	354780229	2.2 $\mu$ F, 50V, Elect.
C405, C406	354780229	2.2 $\mu$ F, 50V, Elect.
C407, C408	371122234	0.022 $\mu$ F $\pm$ 5%, 50V, Mylar
C409, C410	354780339	3.3 $\mu$ F, 50V, Elect.
C411, C412	371122234	0.022 $\mu$ F $\pm$ 5%, 50V, Mylar
C413, C414	354741019	100 $\mu$ F, 16V, Elect.
	<b>Resistors</b>	
R405	5104225	N11RGL250KWT22Z, Variable, Balance
R417	5104230	N14RLC100KWT22Z, Variable, Treble
R421	5104230	N14RLC100KWT22Z, Variable, Bass
	<b>Socket</b>	
JL304a	25050267	NSCT-3P95

#### SPEAKER SWITCH PC BOARD (NASW-3561-3/3A)

CIRCUIT NO.	PART NO.	DESCRIPTION
R551, R552	441622714	270ohm, 1W, Metal oxide film resistors
S551	25035610	NPS-122-142-L572, Speaker switch
P551	25045256	YKB21-5010, Headphone jack <D>
	25045255	YKB21-5009, Headphone jack <G/W>

#### VOLUME PC BOARD (NAETC-3562-3)

CIRCUIT NO.	PART NO.	DESCRIPTION
Q403	222963	LB1630, IC
C423, C424	371124734	0.047 $\mu$ F $\pm$ 5%, 50V, Mylar capacitors





## PRINTED CIRCUIT BOARD VIEW FROM BOTTOM SIDE

## POWER SUPPLY PC BOARD

CIRCUIT NO.	PART NO.	DESCRIPTION
C425	354721019	100 $\mu$ F, 6.3V, Elect. capacitor
R439	5104243	N16RGM100KBTP25F, Variable resistor, Volume
S421	25035609	NPS-122-L571, Push switch, Loudness

## POWER SUPPLY CIRCUIT PC BOARD (NAPS-3563-3/3A/3B)

CIRCUIT NO.	PART NO.	DESCRIPTION
C901	3500065A	$\Delta$ DE7150FZ103P AC400V/125V, Capacitor IS
	27301216	$\Delta$ SB1925, Cover for C901 <G/W>
R901	431523355	$\Delta$ 3.3Mohm, 1/2W, Solid resistor <D>

NOTE: THE COMPONENTS IDENTIFIED BY MARK  $\Delta$  ARE CRITICAL FOR RISK OF FIRE AND ELECTRIC SHOCK. REPLACE ONLY WITH PART NUMBERS SPECIFIED.

CIRCUIT NO.	PART NO.	DESCRIPTION
S901	25035550	$\Delta$ NPS-111-L512P, Power switch
F901a	250113	$\Delta$ SN5051, Fuseholder <D/W>
F902a	25050065	$\Delta$ YSH4037, Fuseholder <G/W>
F901	252049	$\Delta$ 4A (ST-6), Fuse, primary <D/W>
F902	252074	$\Delta$ 2A-SE-EAK, Fuse, primary <G/W>
	29360626-1	$\Delta$ Label, fuse <D>

NOTE: <D> : Only 120V model  
<G> : Only 220V/240V models  
<W> : Only Worldwide model

# BLOCK DIAGRAM

— 120V MODEL —

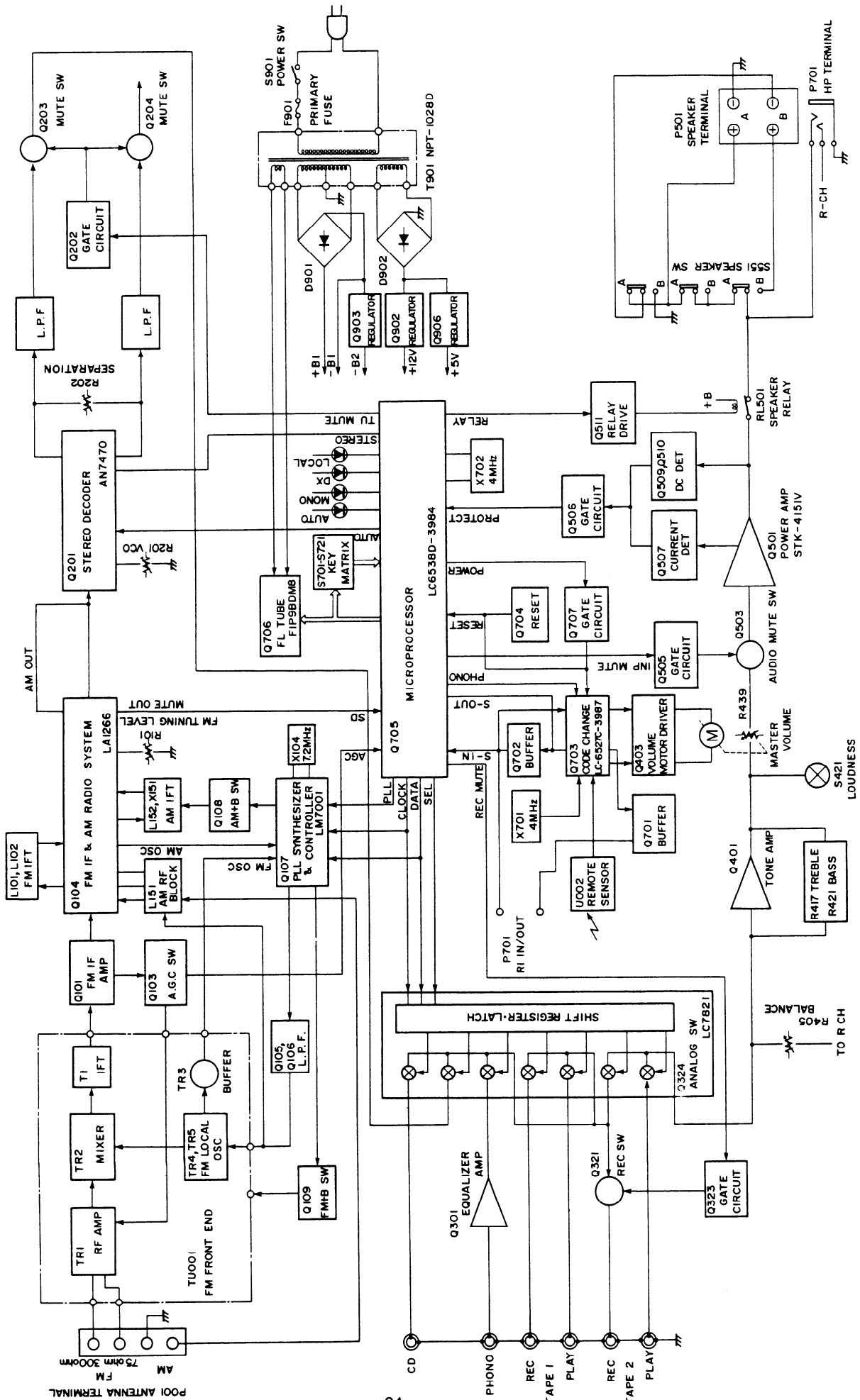

— OTHER MODELS —

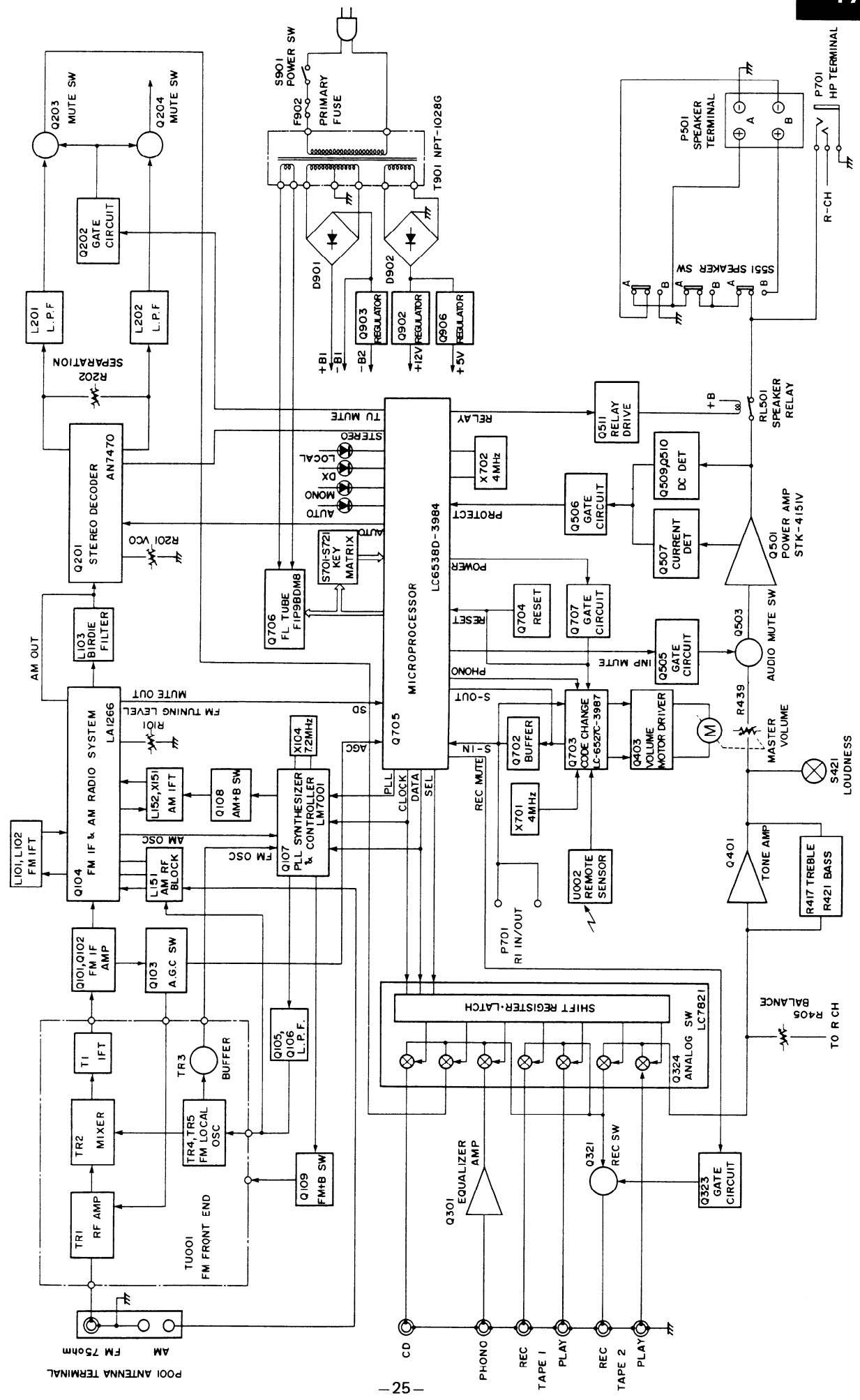

## PACKING VIEW

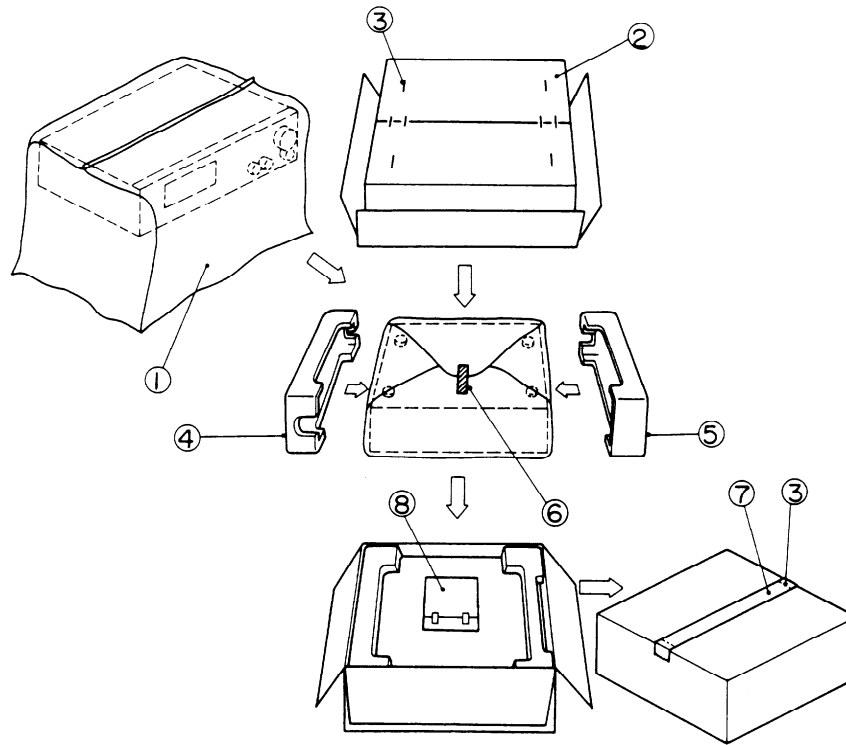

REF. NO.	PART NO.	DESCRIPTION
1	29100034AY	850 × 650mm, Poly-vinyl bag
2	29052019Y	Master carton box
3	282301	Sealing hook
4	29091328BY	Pad R
5	29091327BY	Pad L
6	261504	Adhesive tape
7	260012	Damplon tape
8	Accessory bag ass'y	
<b>-120V model-</b>		
	29341487Y	Instruction manual
	292064B	FM antenna
	232140	NMA-3057, AM loop antenna
	2010169	Connection cord for RI
	3010054	UM-3, Two batteries
	24140144A	RC-144S, Remote control transmitter
	29100097Y	250 × 350mm, Poly-vinyl bag
	29365019Y	Warranty card (U.S.A. model)
	29358002GY	Service station list (U.S.A. model)
	29341488Y	Instruction manual (Only Canadian model)
<b>-220V/240V models-</b>		
	29341488Y	Instruction manual
	292092	FM antenna
	232140	NMA-3057, AM loop antenna
	2010169	Connection cord for RI
	3010054	UM-3, Two batteries
	24140148	RC-148S, Remote control transmitter
	29100097Y	250 × 350mm, Poly-vinyl bag
	25060123	FM adaptor (240V model)
<b>-Worldwide model-</b>		
	2934188Y	Instruction manual
	292092	FM antenna
	232140	NMA-3057, AM loop antenna
	2010169	Connection cord for RI
	3010054	UM-3, Two batteries
	24140148	RC-148S, Remote control transmitter
	29100097Y	250 × 350mm, Poly-vinyl bag
	25060123	FM adaptor
	25055040	CV-K-2, Conversion plug

## ONKYO CORPORATION

International Division: No. 24 Mori Bldg., 23-5, Nishi-Shimbashi 3-chome, Minato-ku,  
TOKYO 105, JAPAN Telex: 242-3551 ONKYO J. Tel. 03-432-6981

## ONKYO U.S.A CORPORATION

200 Williams Drive, Ramsey, N.J. 07446 Tel. 201-825-7950