

# ONKYO SERVICE MANUAL

## QUARTZ SYNTHESIZED TUNER AMPLIFIER MODELS TX-830/TX-830M

### Black model

BHUD, BHUDN, MBHUDN	120V AC, 60Hz
BHUG	220V AC, 50Hz
BHUQA	240V AC, 50Hz
BHUW	120/220V AC, 50/60Hz

**SAFETY-RELATED COMPONENT WARNING!!**  
COMPONENTS IDENTIFIED BY MARK  $\Delta$  ON THE SCHEMATIC DIAGRAM AND IN THE PARTS LIST ARE CRITICAL FOR RISK OF FIRE AND ELECTRIC SHOCK. REPLACE THESE COMPONENTS WITH ONKYO PARTS WHOSE PART NUMBERS APPEAR AS SHOWN IN THIS MANUAL.

MAKE LEAKAGE-CURRENT OR RESISTANCE MEASUREMENTS TO DETERMINE THAT EXPOSED PARTS ARE ACCEPTABLY INSULATED FROM THE SUPPLY CIRCUIT BEFORE RETURNING THE APPLIANCE TO THE CUSTOMER.

## TABLE OF CONTENTS

Specifications	2
Service procedures	3
Exploded view	4
Parts list	5
Block diagram -120V model-	6
Block diagram -220V model-	8
Connection diagram of microprocessor	10
Block diagram of IC	11
Adjustment procedures	18
Pc board view/parts list	
Display/preamp./speaker	21
AM/FM tuner and selector circuit	25
Power amplifier	30
Other pc boards	33
Schematic diagram	
120V model -Tuner-	23
120V model -Amp.-	27
Other models -Tuner-	31
Other models -Amp.-	35
Disassembling procedures	37
Packing view	38

**ONKYO**  
**AUDIO COMPONENTS**

# SPECIFICATIONS

## AMPLIFIER SECTION

Power output:	58 watts per channel, min. RMS, at 8ohms, both channels driven, from 20Hz to 20kHz, with no more than 0.08% total harmonic distortion.
Musical Power Output:	2 × 150 watts at 4 ohms, 1kHz (DIN)
Continuous Power Output:	2 × 90 watts at 8 ohms, 1kHz (DIN)
Total Harmonic Distortion:	2 × 85 watts at 4 ohms, 1kHz (DIN)
	2 × 65 watts at 8 ohms, 1kHz (DIN)
IM Distortion:	0.08% at rated power
	0.08% at 1 watts output
Damping Factor:	0.08% at 1 watts output
Frequency Response:	40 at 8 ohms
RIAA Diviation:	20-30,000Hz ±1dB
Sensitivity and Impedance:	20-20,000Hz ±0.8dB
	Phono: 2.5mV/50 kohms
	CD: 150mV/50 kohms
	Tape Play: 150mV/50 kohms
	Tape Rec: 150mV/3.5 kohms
Phono Overload(MM):	120mV RMS at 1kHz, 0.08% THD.
Signal-to-Noise Ratio:	Phono: 85dB(at 10mV input, A weighted)
	75dB(IHF A-202)
	CD/Tape: 95dB(A weighterd)
	80dB(IHF A-202)
Tone controls:	Bass: ±10dB at 100Hz
	Treble: ±10dB at 10kHz

## TUNER SECTION

### FM:

	-220V/240V/ Worldwide models-	-120V model-
Tuning Range:	87.50-108.00MHz(50kHz steps) 87.50-108.00MHz(50kHz steps) or 87.9-107.9kHz(200kHz steps) (Worldwide model)	87.9-107.9kHz(200kHz steps)
Usable Sensitivity:	Mono: 12.8dBf, 1.2 μV, 75ohms 1.0 μV(S/N 26dB, 40kHz Devi.) 75ohms DIN	Mono: 11.2dBf, 2.0 μV
	Stereo: 18.0dBf, 2.2 μV, 75ohms 23μV(S/N 46dB, 40kHz Devi.) 75ohms DIN	Stereo: 17.2dBf, 4.0 μV
50dB Quieting Sensitivity:	Mono: 18.0dBf, 2.2 μV, 75ohms	Mono: 17.2dBf, 4.0 μV
	Stereo: 37.2dBf, 20μV, 75ohms	Stereo: 37.2dBf, 40μV
Capture Ratio:	1.5dB	1.5dB
Image Rejection Ratio:	85dB	40dB
IF Rejection Ratio:	90dB	90dB
Signal-to-Noise Ratio:	Mono: 72dB	Mono: 72dB
	Stereo: 66dB	Stereo: 66dB
Alternate Channel Attenuation:		55dB
Selectivity:	50dB DIN( ±300kHz, 40kHz dev.)	
AM suppression Ratio:	50dB	50dB
Harmonic Distortion:	Mono: 0.15%	Mono: 0.15%
	Stereo: 0.30%	Stereo: 0.30%
Frequency Response:	30-15,000Hz ±1.5dB	30-15,000Hz ±1.5dB
Stereo Separation:	45dB at 1kHz	45dB at 1kHz
	30dB at 100-10,000Hz	30dB at 100-10,000Hz
Muting Level:	17.2dBf, 4.0μV	17.2dBf, 4.0μV
<b>AM:</b>		
Tuning Range:	522-1611kHz( 9kHz steps) 522-1611kHz( 9kHz steps) or 530-1620kHz(10kHz steps) (Worldwide model)	530-1620kHz(10kHz steps)
Usable Sensitivity:	30μV	30μV
Image Rejection Ratio:	40dB	40dB
IF Rejection Ratio:	40dB	40dB
Signal-to-Noise Ratio:	40dB	40dB
Harmonic Distortion:	0.7%	0.7%

## GENERAL

Dimensions(W × H × D):	435 × 130 × 351mm
	17-1/8" × 5-1/8" × 13-13/16"
Weight:	8.2kg., 18.1lbs.

**REMOTE CONTROL TRANSMITTER RC-119S/RC-118S**

Transmitter: Infrared  
 Signal range: Approx. 5meters(16ft.4")  
 Power supply: TWO "AA" batteries (1.5V×2)  
 Dimensions(W×H×D): 64×18×176mm  
 2-1/2 " ×3/4 " × 7"  
 Weight: 140grams 5.0oz.(including batteries)

Specifications and features are subject to change without notice.

**SERVICE PROCEDURES**

**1. Replacing the fuses**

For continued protection against fire hazard, replace only with same type and same rating fuse.

D (120V) model

Circuit no.	Part no.	Description
F901	252050	5 A (ST-6), Primary

G (220V) and Q (240V) models

Circuit no.	Part no.	Description
F902	252075	2.5A-SE-EAK, Primary
F903	252075	2.5A-SE-EAK, AC outlet (Only 220V model)

F906 252070 1A-SE-EAK, Secondary

W (Worldwide) model

Circuit no.	Part no.	Description
F901	252050	5A (ST-6), Primary
F902	252075	2.5A-SE-EAK, Primary

**2. Change of FM/AM band step.**

With the exception of the models below, a BAND STEP selector switch is not provided.

(FM)

MODEL	BAND STEP	D717, J753	R119
UD	200kHz→50kHz	Additional	15kΩ→24kΩ
UG/UQ	50kHz→200kHz	Eliminated	24kΩ→15kΩ

(AM)

BAND STEP	D716, J754
10kHz→ 9kHz	Additional
9kHz→10kHz	Eliminated

In D716/7 1SS133 (Part No. 223163) is used. In J753/4, a jumper lead must be inserted. R119, with the muting amplitude determined, is on the back panel side of FM/AM tuner and selector circuit printed circuit board assembly test points TP-1 and TP-2.

– Worldwide model –

Worldwide models are equipped with a step band selector switch. This switch is located on the back panel. This switch is set to 50kHz (FM) and 9kHz (AM) at the factory, but may have to be reset to 200kHz and 10kHz depending on the area where the unit is used.

	De-emphasis	FM step	AM step
Europe:	50 μsec	50kHz	9kHz
U.S.A.:	75 μsec	200kHz	10kHz

**3. Memory preservation**

This unit does not require memory preservation batteries. A built-in memory power back-up system preserves contents of the memory during power failures and even when the unit is unplugged. The unit must be plugged in

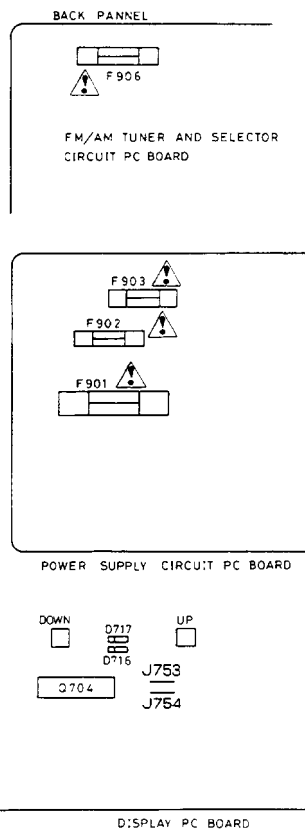

and the power switch turned on and off once in order to charge the back-up system. Note that since this is not a permanent memory the power switch must be turned on and off a few times each month to keep the back-up system operative. The period of time during which memory contents are preserved after power has last been turned off varies depending on climate and placement of the unit. On the average, memory contents are protected over a period of 3 to 4 weeks (a minimum of 2 weeks) after the last time power has been turned off. This period is shorter when the unit is exposed to very high humidity or used in an area with an extremely humid climate.

**4. Safety-check out**

(Only U.S.A. model)

After correcting the original service problem perform the following safety check before releasing the set to the customer.

Connect the insulating-resistance tester between the plug of power supply cord and terminal GND on the back panel. Specifications: 3.3 Mohm ±10% at 500V.

**5. Change of voltage**

Worldwide models are equipped with a voltage selector to conform with local power supplies. This switch is located on the back panel. Be sure to set this switch to match the voltage of the power supply in your area before turning the power switch on.

This switch is set to 220V at the factory. Voltage is changed by sliding the groove in the switch with the screwdriver to the right or left. Confirm that the switch has been moved all the way to the right or left before turning the power switch on.

EXPLODED VIEW

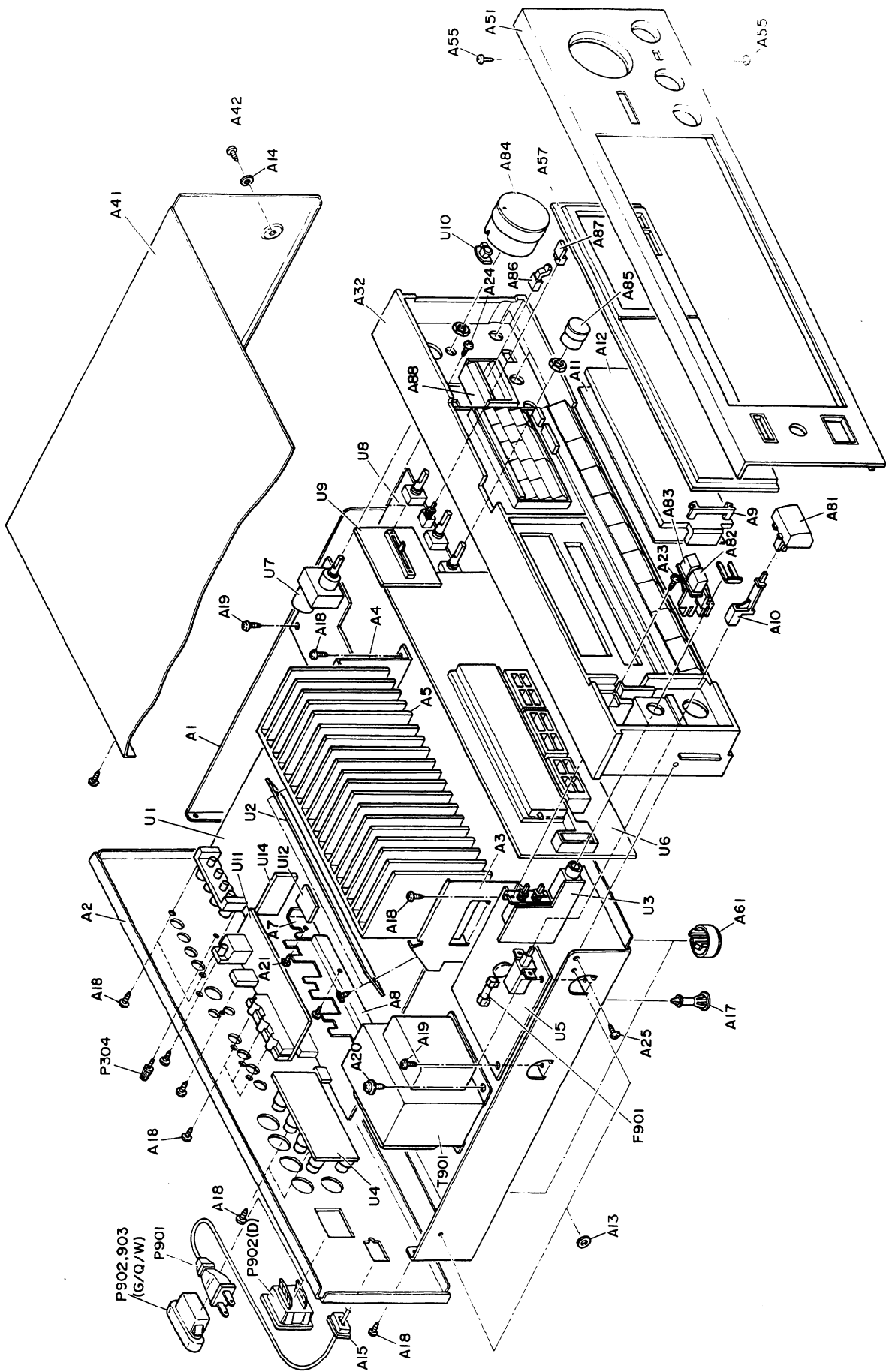

# PARTS LIST

REF. NO.	PART NO.	DESCRIPTION	REF. NO.	PART NO.	DESCRIPTION
A1	27100163	Chassis	U6	1A095581-2	NADIS-3281-2,Display pc board ass'y <D>
A2	27121112	Back panel <D>	U6	1A095581-2A	NADIS-3281-2A, Display pc board ass'y <G/Q>
	27121113	Back panel <G>		1A095581-2B	NADIS-3281-2B, Display pc board ass'y <W>
	27121115	Back panel <W>	U7	1A090582-1	NAAF-3282-1,Volume pc board ass'y <D>
A3	27121116	Back panel <Q>		1A090582-1A	NAAF-3282-1A, Volume pc board ass'y <G/W/Q>
A4	27141261A	Bracket LH	U8	1A095583-2	NAAF-3283-2,Preamplifier pc board ass'y <D>
A4	27141262	Bracket RH		1A095583-2A	NAAF-3283-2A, Preamplifier pc board ass'y <G/W/Q>
A5	27160226A	Radiator	U9	1A095584-2	NAAF-3284-2,Switch pc board ass'y <G/W/Q>
A7	27141263	Bracket SH	U10	1A090585-1	NADIS-3285-1,Volume indicator pc board ass'y
A8	27141264	Bracket H	U11	1A090586-1	NAETC-3286-1,Video terminal pc board ass'y <D>
A9	27190644	Holder,dial plate	U12	1A090587-1	NAETC-3287-1,Power supply circuit pc board ass'y <D>
A10	27273098A	Joint,power		1A090587-1A	NAPS-3287-1A,Power supply circuit pc board ass'y <G>
A11	28133199A	Back plate	U14	1A073554-2	NAAF-3054-2,Equalizer amplifier pc board ass'y <D>
A12	28130250	Dial plate		1A086554-3	NAAF-3054-3,Equalizer amplifier pc board ass'y <G/W/Q>
A13	27270147	Spacer			
A14	870048	3x8x0.8t,Nylon washer			
A15	27300750	Strainrelief			
A17	27190524	Holder			
A18	834430088	3TTS+8B(BC),Tapping screw			
A19	831130088	3TTW+8B,Tapping screw			
A20	830440089	4TTC+8C(BC),Tapping screw			
A21	834430108	3TTS+10B(BC),Tapping screw			
A22	834230108	3TTS+10B(Ni),Nickel screw			
A23	82143006	3P+6FN(BC),Pan head screw			
A24	82142004	2P+4F(BC),Pan head screw			
A25	833430080	3TTP+8P(BC),Tapping screw			
A32	27110418A	Front bracket ass'y			
A41	28184394	Top cover			
A42	834430088	3TTS+8B(BC),Tapping screw			
A43	801230	3STS+8BQ(BC),Tapping screw			
A51	1A096121	Front panel ass'y			
A55	833430080	3TTP+8P(BC),Tapping screw			
A57	28191466A	Clear plate			
A61	27175142	Leg			
A81	28323241	Knob POWER			
A82	28323361	Knob SPEAKER A			
A83	28323363	Knob SPEAKER B			
A84	28323365A	Knob VOLUME			
A85	28323310	Knob TONE			
A86	28322925	Knob SLIDE			
A87	28323367	Knob PUSH			
A88	27190647	Knob SLIDE			
F901	252050	5A(ST-6),Primary fuse <D/W>			
F902	252075	2.5A-SE-EAK,Primary fuse <G/W/Q>			
F903	252075	2.5A-SE-EAK,AC outlet fuse <G>			
F906	252070	1A-SE-EAK,Secondary fuse <G/Q>			
P304	25060044	3x14mm,Terminal GND			
P901	253123, 253136, 253140 or 253146	AS-UC-6 # 18,Power supply cord <D>			
	253150	AS-CEE,Power supply cord <G/W>			
	253118	AS-SAA,Power supply cord <Q>			
P902	25050341	NSCT-4P168T,AC outlet <D>			
P902,P903	25050337	NSCT-2P164,AC outlet <G/W>			
Q521,Q522	2501703, 2201704 or 2201706	2SC3855(O), 2SC3855(Y) or 2SC3855(P),Power amplifier transistor			
Q523,Q524	2201693, 2201694 or 2201696	2SA1491(O), 2SA1491(Y) or 2SA1491(P),Power amplifier transistor			
S903	25065123	NPS-1258P,Voltage selector switch <W>			
T901	2300306 2300307 2300308	NPT-993D,Power transformer <D> NPT-993G,Power transformer <G> NPT-993DG,Power transformer <W>			
U1	2300340 1A095576-2 1A095576-2A	NPT-993Q,Power transformer <Q> NAAR-3276-2,FM/AM tuner and selector circuit pc board ass'y <D> NAAR-3276-2A, FM/AM tuner and selector circuit pc board ass'y <G/Q>			
U2	1A095577-2	NAAF-3277-2,Power amplifier pc board ass'y			
U3	1A095578-2	NASW-3278-2,Speaker switch pc board ass'y <D/W>			
U4	1A095578-2A 1A090579-1 1A090579-1A	NASW-3278-2A, Speaker switch pc board ass'y <G/Q> NAETC-3279-1,Speaker terminal pc board ass'y <D> NAETC-3279-1A, Speaker terminal pc board ass'y <G/W/Q>			
U5	1A090580-1	NAETC-3280-1,Const. voltage circuit pc board ass'y			

NOTE: <D>: Only 120V model  
 <G>: Only 220V model  
 <W>: Only Worldwide model  
 <Q>: Only 240V model

NOTE: THE COMPONENTS IDENTIFIED BY MARK Δ ARE CRITICAL FOR RISK OF FIRE AND ELECTRIC SHOCK. REPLACE ONLY WITH PART NUMBERS SPECIFIED.

# BLOCK DIAGRAM

-120V MODEL -  
TUNER SECTION

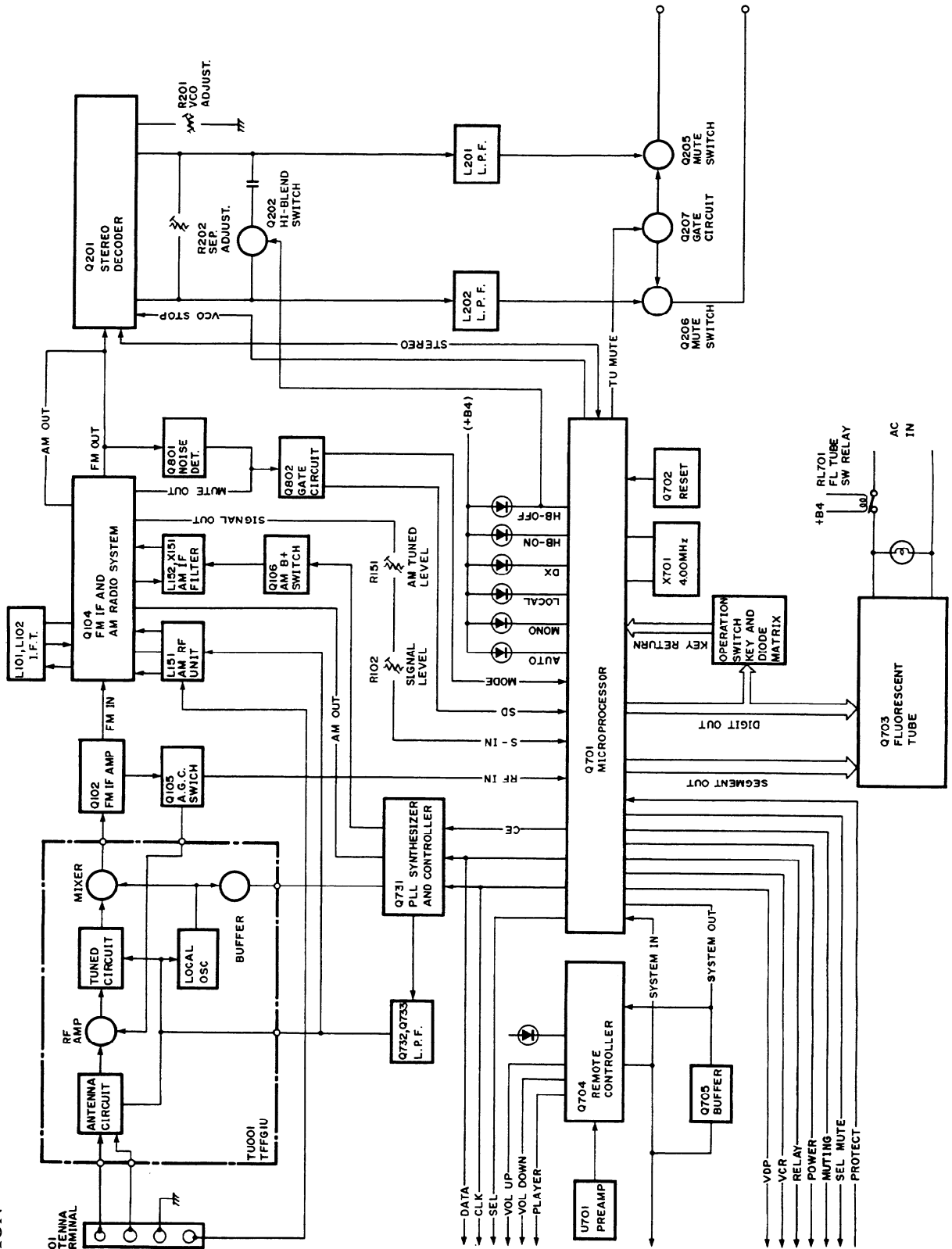

AMPLIFIER SECTION

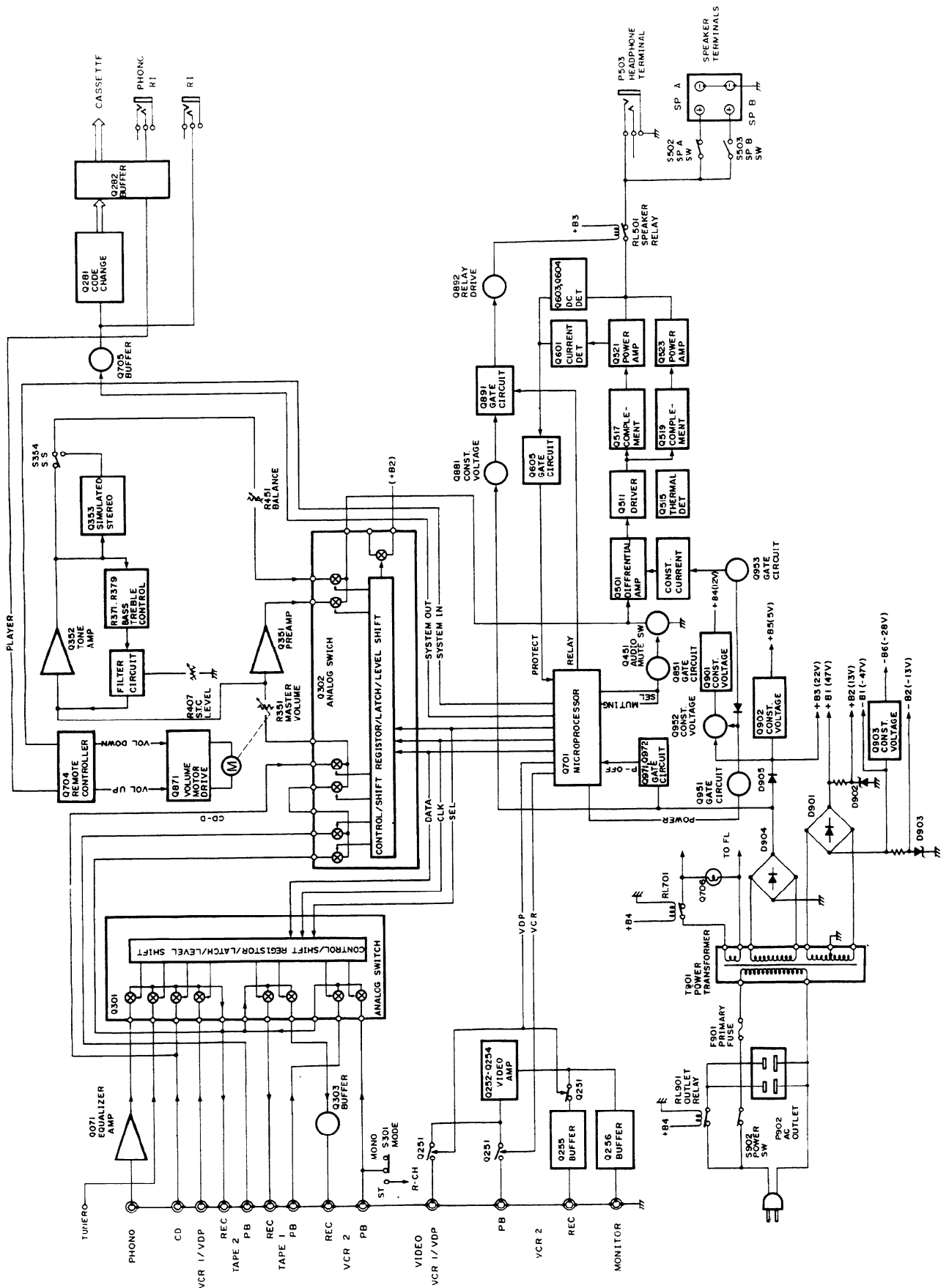

# BLOCK DIAGRAM

—OTHER MODELS—  
TUNER SECTION

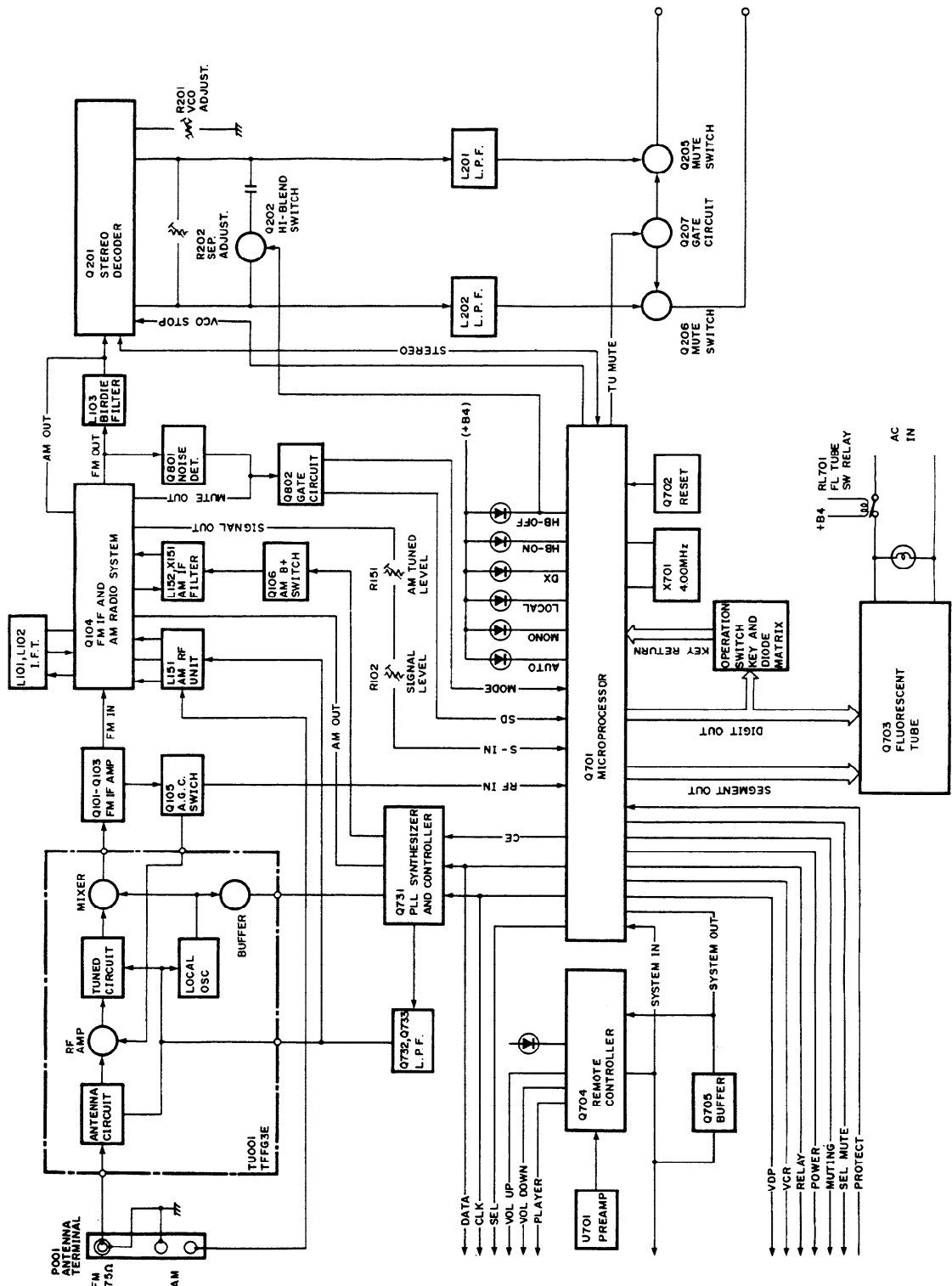



AMPLIFIER SECTION

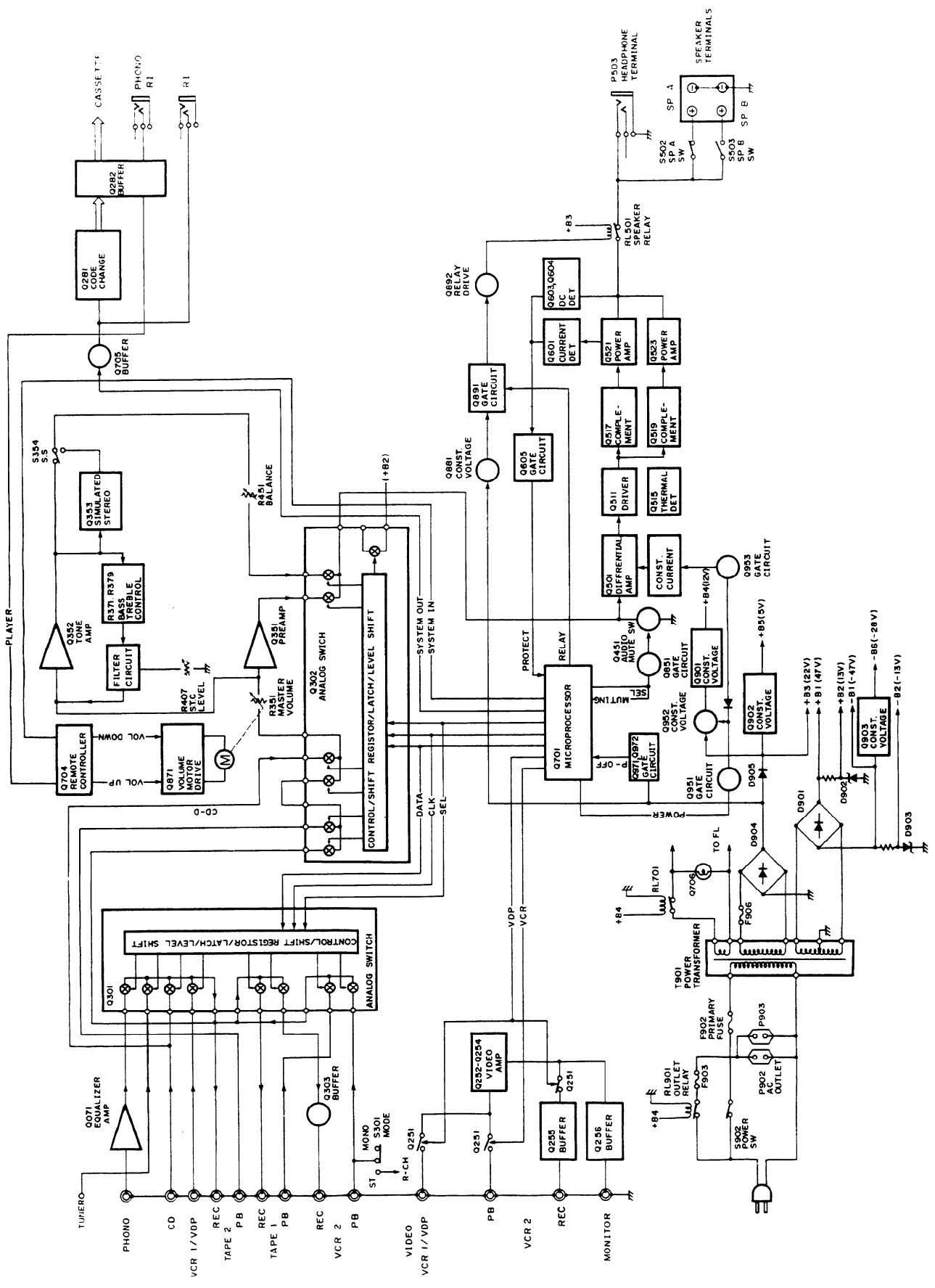

# CONNECTION VIEW OF MICROPROCESSOR

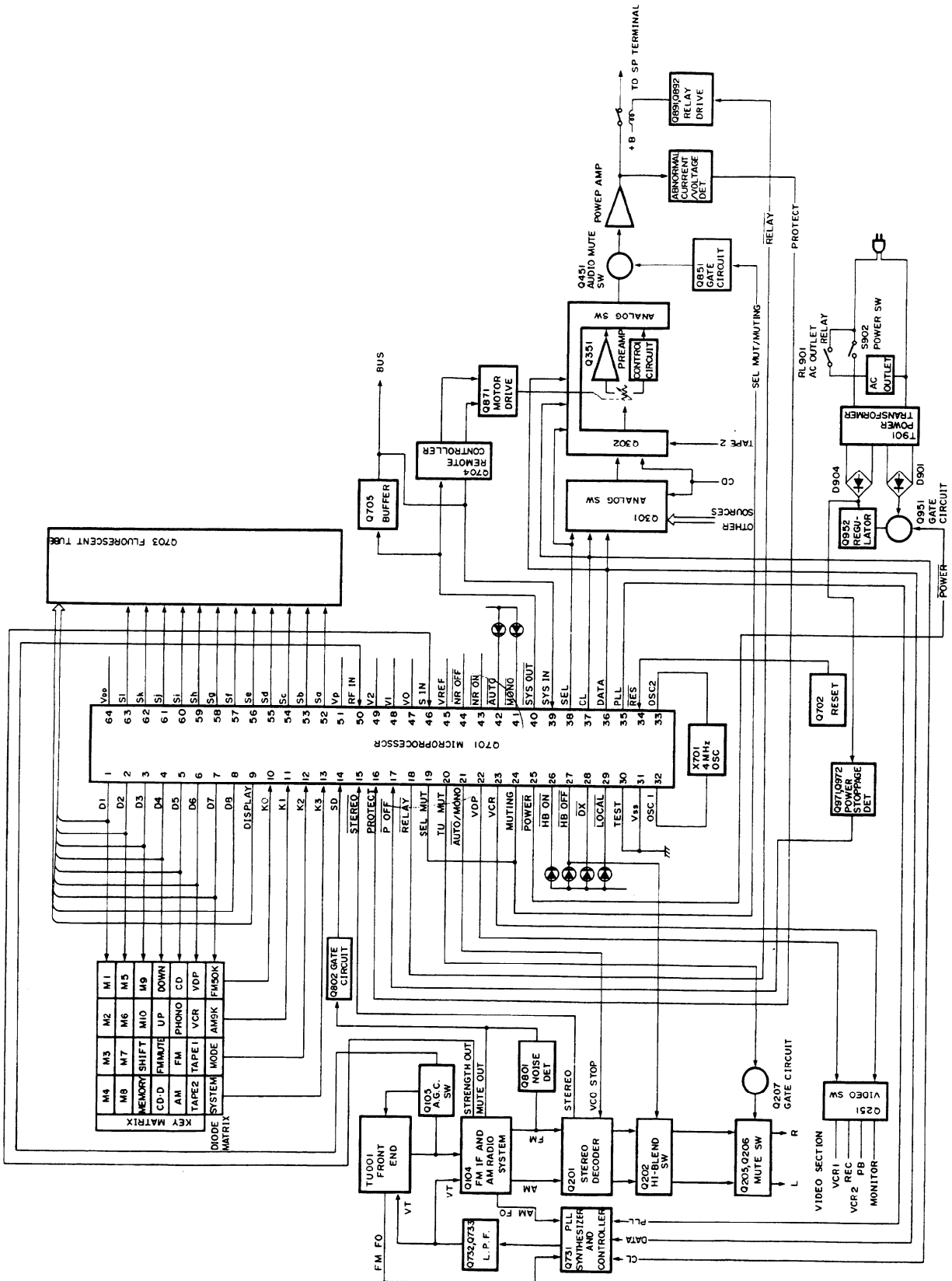

# BLOCK DIAGRAM OF ICS

## LC6568H-3643 (MICROPROCESSOR)

### Terminal Descriptions

Pin No.	Terminal	Description
1	D1	These are the digit and key scan signal terminals. "H" when active.
2	D2	
3	D3	
4	D4	
5	D5	
6	D6	
7	D7	
8	D8	
9	DISPLAY	Display output terminal."H" when active.
10	K0	These are the input terminal for key return signal source and diode matrix."H" when active.
11	K1	
12	K2	
13	K3	
14	SD	Auto stop signal input terminal.Auto tuning stops when this terminal becomes the high level.
15	STEREO	This is the input terminal for detection of the stereo broadcast."L" when active.
16	PROTECT	This is the detection terminal for protection circuit.The speaker relay turns off when this terminal becomes the high level.
17	POWER OFF	This is the input terminal for detection of the stoppage of electric current."L" when the stoppage of electric current.
18	RELAY	This is the output terminal for control of the speaker relay."L" when active.
19	SEL MUTE	This is the muting output terminal when the selector key is operated."H" when active.
20	TU MUTE	This is the output terminal for muting control of tuner section."L" when active.
21	AUTO/MONO	This is the AUTO/MONO switching output terminal. "L" when AUTO.
22	VDP	These are the output terminal for control of video signal.
23	VCR	
24	MUTING	This is the output terminal for muting control. "H" when active.
25	POWER	This is the output terminal for power source.It is "H" for power on.
26	HB ON	This is the output terminal for indication of HI-BLEND ON. "L" when active.
27	HB OFF	This is the output terminal for indication of HI-BLEND OFF. "L" when active.
28	DX	This is the output terminal for indication of DX. "L" when active.
29	LOCAL	This is the output terminal for indication of LOCAL. "L" when active.
30	TEST	Test terminal.Connect to the ground.
31	Vss	Ground terminal.
32	OSC1	Connect to the 4.00MHz ceramic oscillator.
33	OSC2	
34	RES	This is the input terminal for reset. "L" when active
35	PLL	Connect to the terminal CE of PLL IC(LM7001).
36	DATA	This is the serial data output terminal.Connect to the terminal DATA of PLL IC and terminal DI of analog switches. (LC7821/LC7823)
37	CLOCK	This is the serial clock output terminal.Connect to the terminal CI of PLL IC and terminal CL of analog switches.
38	SEL	Connect to terminal SEL of analog switch(LC7821).
39	SYSTEM IN	This is the input terminal for system code. "H" when active.
40	SYSTEM OUT	This is the input terminal for system code. "L" when active.
41	MONO	This is the output terminal for indication of MONO. "L" when active.
42	AUTO	This is the output terminal for indication of AUTO. "L" when active.
43	NR ON	This is the output terminal for indication of NR ON. "L" when active.
44	NR OFF	This is the output terminal for indication of NR OFF. "L" when active.
45	VREF	This is the input terminal for comparator reference voltage.
46	S IN	This is the signal strength input terminal.
47	V0	This is the output terminal for comparator reference voltage.
48	V1	This is the output terminal for comparator reference voltage.
49	V2	This is the output terminal for comparator reference voltage.
50	RF IN	This is the input terminal for control of AGC. "H" when active.
51	VP	Pull-down resistor connection terminal of FIP controller/driver.

Pin No.	Terminal	Description
52	Sa	These are the output terminal for segment signal. "H" when active.
53	Sb	
54	Sc	
55	Sd	
56	Se	
57	Sf	
58	Sg	
59	Sh	
60	Si	
61	Sj	
62	Sk	This is the device power source terminal. At the time of operation, the supply is 5V. The internal data memory (RAM) is maintained by means of the super capacitor.
63	Sl	
64	VDD	

**FM50K (FM band setting)**

FM50K	Region	Frequency range	Channel space	Reference frequency	IF frequency
1	Europen	87.50 ~ 108.00MHz	50kHz	25kHz	10.7MHz
0	U.S.A.	87.9 ~ 107.9MHz	200kHz	25kHz	10.7MHz

**AM9**

AM9K	Region	Frequency range	Channel space	Reference frequency	IF frequency
1	Europen	522 ~ 1611 kHz	9kHz	9kHz	450kHz
0	U.S.A.	530 ~ 1620 kHz	10kHz	10kHz	450kHz

**Connection of fluorescent tube and microprocessor**

**ANODE CONNECTION**

	8 G (D 8)	7 G (D 7)	6 G (D 6)	5 G (D 5)	4 G (D 4)	3 G (D 3)	2 G (D 2)	1 G (D 1)
a	SLEEP		a	a	a	a	a	a
b	CD DIRECT		b	b	b	b	b	b
c	MEMORY		c	c	c	c	c	c
d	11-20		d	d	d	d	d	d
e	1-10	FM FM MUTE	e	e	e	e	e	e
f	AUDIO MUTE	STEREO	f	f	f	f	f	f
g	-	AM	g	g	g	g	g	g
h	T-2 MONITOR	OFF	-	-	-	h	-	h
i	-	ON	i	-	i	-	-	i
j	-	MIN	j	-	-	-	-	j
k	-	kHz	-	-	k	k	-	k
l	-	MHZ	-	-	DP	-	-	CH
m	PRESET STATION	-	-	-	-	-	-	-
n	SIGNAL FREQUENCY INPUT SELECTOR	-	-	-	-	-	-	-
o	-	SIGNAL STRENGTH	-	-	-	-	-	-
p	-		-	-	-	-	-	-

**μPA81C (BUFFER)**

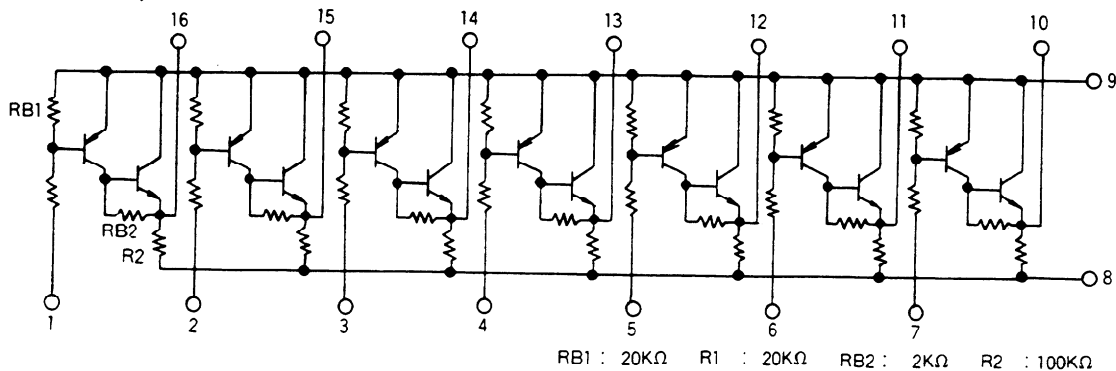

RB1 : 20KΩ R1 : 20KΩ RB2 : 2KΩ R2 : 100KΩ

7-BT-95GK (FLUORESCENT TUBE)

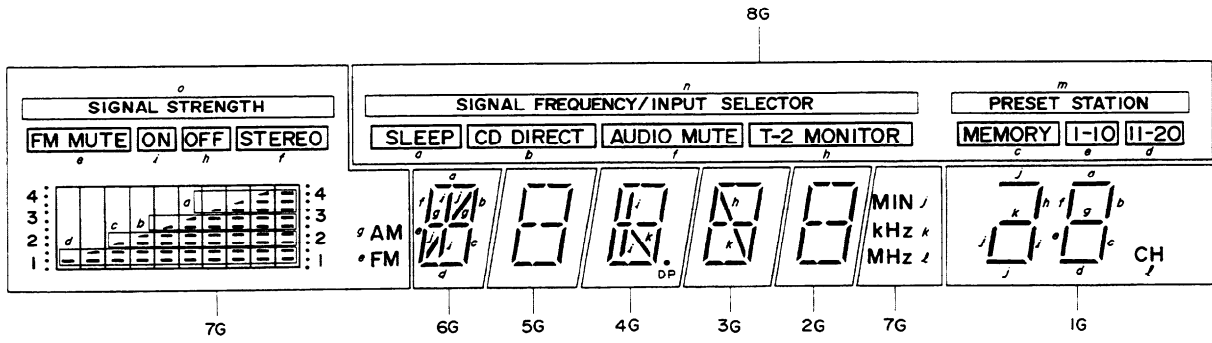

LC7823 (ANALOG SWITCH)

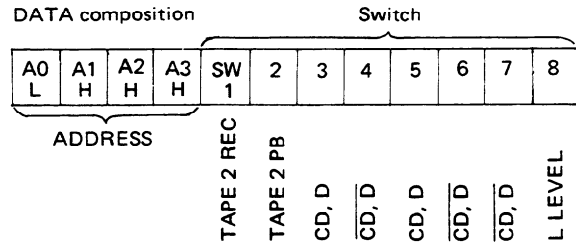
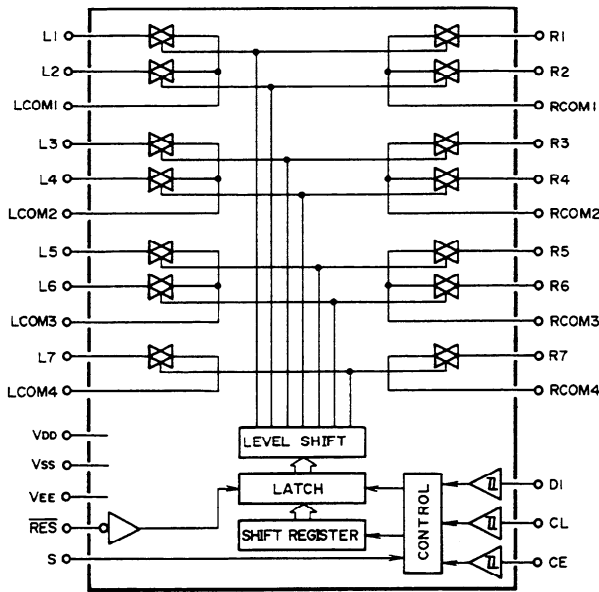

The source becomes ON when the bit of switch becomes high.

Pin No.	Terminal	Description	Pin No.	Terminal	Description
1 (L1)	TAPE 2 REC	Input/output terminals of audio signal of left channel. Control to the inside analog switch at the serial data.	16	VSS	Ground terminal.
2 (L2)	TAPE 2 PB		17	S	Selector terminal.
3	L COM 1		18	RES	Reset terminal. When power is turned ON, the condition of the analog switch is not determined, but when this terminal is "L", all analog switches are OFF.
4 (L3)	CD·D		19	VDD	Power supply terminal. (+15V)
5 (L4)	CD·D		20	R COM 4	Input/output terminals of audio signal of right channel. Control to the inside analog switch at the serial data.
6	L COM 2		21 (R7)	CD·D	
7 (L5)	CD·D		22	R COM 3	
8 (L6)	CD·D		23 (R6)	CD·D	
9	L COM 3		24 (R5)	CD·D	
10 (L7)	CD·D		25	R COM 2	
11	L COM 4		26 (R4)	CD·D	
12	VEE	27 (R3)	CD·D		
13	CE	28	R COM 1		
14	D1	29 (R2)	TAPE 2 PB		
15	CL	30 (R1)	TAPE 2 REC		

LC7821 (Analog switch)

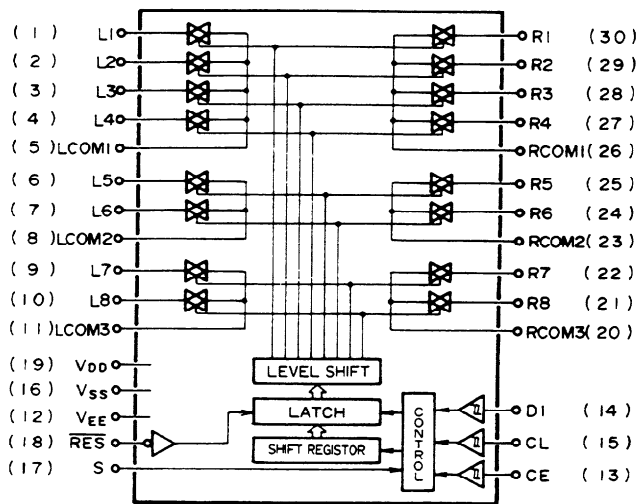

DATA composition

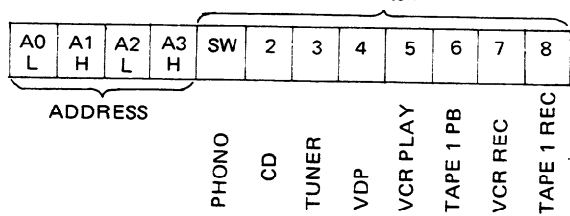

The source becomes ON when the bit of switch becomes high.

Pin No.	Terminal	Description	Pin No.	Terminal	Description
1	PHONO	Input/output terminals of audio signal of left channel. Control to the inside analog switch at the serial data.	16	Vss	Ground terminal.
2	CD		17	S	Selector terminal.
3	TUNER		18	RES	Reset terminal. When power is turned ON, the condition of the analog switch is not determined, but when this terminal is "L", all analog switches are OFF.
4	VDP		19	VDD	Power supply terminal. (+15V)
5	L COM 1		20	R COM 3	Input/output terminals of audio signal of right channel. Control to the inside analog switch at the serial data.
6	VCR PB		21	TAPE 1 REC	
7	TAPE 1 PB		22	VCR REC	
8	L COM 2		23	R COM 2	
9	VCR REC		24	TAPE 1 PB	
10	TAPE 1 REC		25	VCR P	
11	L COM 3		26	R COM 1	
12	Vss	27	VDP		
13	CE	28	TUNER		
14	D1	29	CD		
15	CL	30	PHONO		

μPC1161C3 (FM stereo decoder)

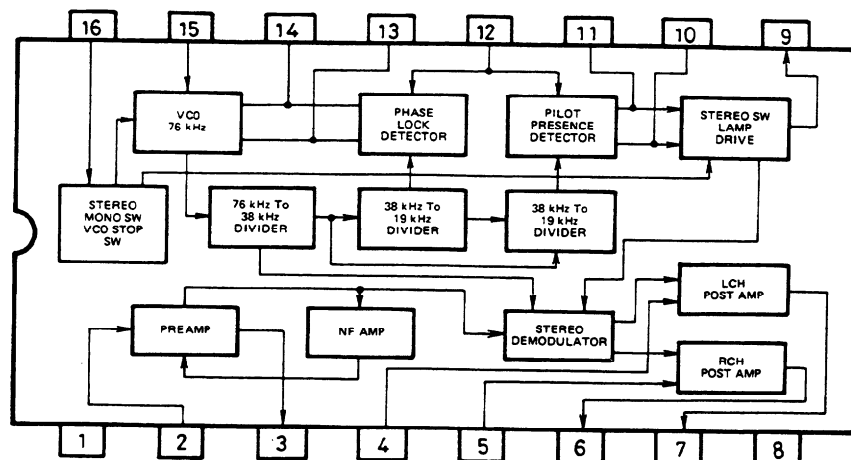

## LM7001 (PLL SYNTHESIZER AND CONTROLLER)

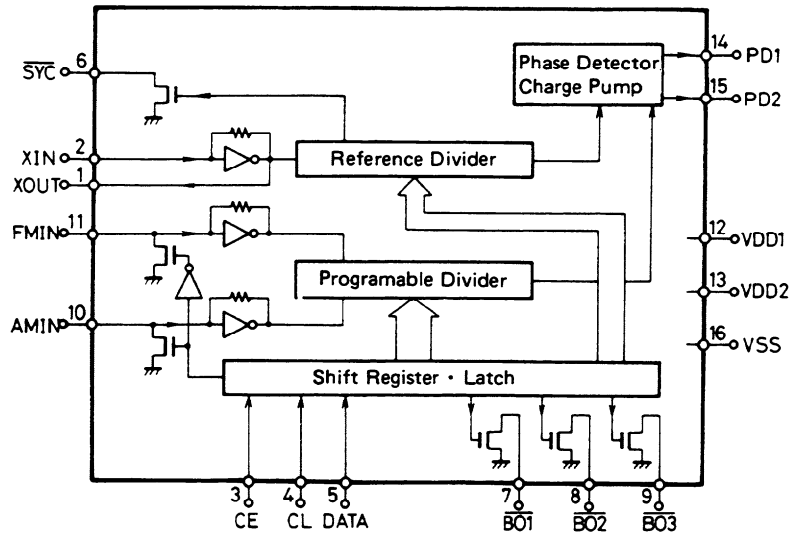

Pin No.	Terminal	Description
1	XOUT	Connect to the 7.2 MHz crystal oscillator.
2	XIN	
3	CE	Chip enable terminal. Connect to the PLL terminal of LC6568H-3643.
4	CL	Serial clock input terminal. Connect to the CLOCK terminal of LC6568H-3643.
5	DATA	Serial data input terminal. Connect to the DATA terminal of LC6568H-3643.
6	$\overline{\text{SYN}}$	Not used.
7	$\overline{\text{BO1}}$	Phono control signal output terminal. "L" when phono.
8	$\overline{\text{BO2}}$	FM control signal output terminal. "L" when FM.
9	$\overline{\text{BO3}}$	AM control signal output terminal. "L" when AM.
10	AMIN	AM local oscillator input terminal.
11	FMIN	FM local oscillator terminal.
12	VDD 1	Power supply terminal for back-up.
13	VDD 2	Power supply terminal.
14	PD1	Charge pump output of the phase detector which constitutes the PLL. High level is output when the divided local oscillator frequency is high than the reference frequency. In the opposite case, low level is output. Floating occurs when the frequencies matched. The output is applied to the variable capacitor diode in the local oscillator through the low pass filters.
15	PD2	
16	Vss	Ground terminal.

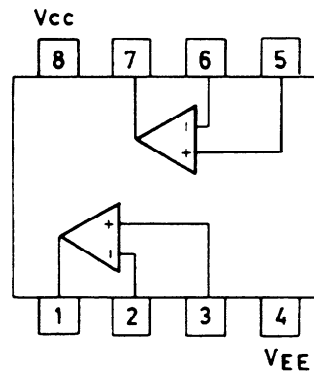
 $\mu$ PC4570C (OP AP)

## LC6527C-3608 (REMOTE CONTROLLER)

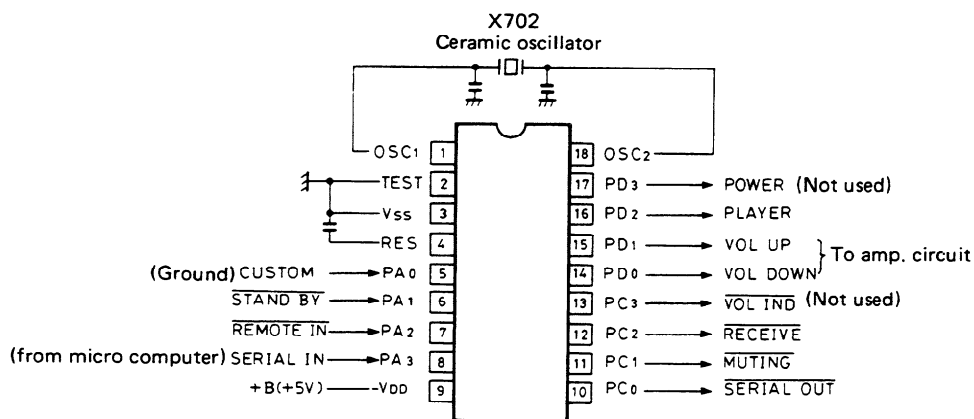
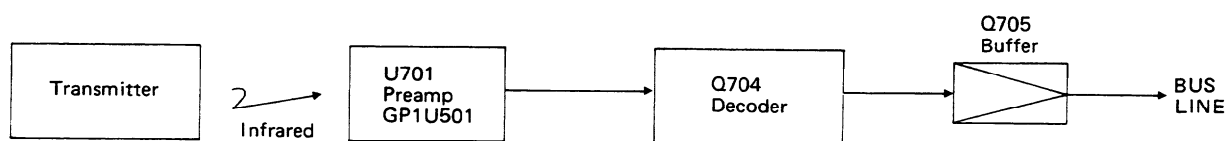

Connection diagram

Terminal No.	Symbol	Terminal	Description
1 18	OSC1 OSC2	OSC	Connect to the 1MHz ceramic oscillator.
2	TEST	TEST	Test terminal. Connect to the ground.
3	V <sub>ss</sub>	GND	Ground terminal.
4	$\overline{\text{RES}}$	$\overline{\text{RES}}$	Reset terminal.
5	PA0	CUSTOM	The custom code for decode is selected at this terminal. For U.S.A., the level is low.
6	PA1	$\overline{\text{STANDBY}}$	Terminal for STANDBY detection. During low input, only the POWER code is decoded.
7	PA2	$\overline{\text{REMOTE IN}}$	Signal input terminal for remote control preamp. Active low.
8	PA3	$\overline{\text{SERIAL IN}}$	
9	V <sub>DD</sub>	+B	Power supply terminal.
10	PC0	$\overline{\text{SERIAL OUT}}$	Output at this terminal are the custom code (16 bit) remote control code input to REMOTE IN, data code (8 bit), and the serial code (12 bit) that has been converted corresponding to the decoded data code (8 bit).
11	PC1	$\overline{\text{MUTING}}$	At this terminal, the audio muting code that is input is inverted for each L/H. When power is ON, the level is high.
12	PC2	$\overline{\text{RECEIVE}}$	This is the display output for remote control reception. Output is low when decoded code is being received.
13	PC3	$\overline{\text{VOL IND}}$	During output of VOLUME UP/DOWN, a pulse ( $\overline{\text{J T T T}}$ ; T = 0.3ms) is output.
14	PD0	VOL DOWN	When the volume DOWN code is input, a high pulse of 120ms is output.
15	PD1	VOL UP	When the volume UP code is input, a high pulse of 120ms is output.
16	PD2	PLAYER	When the player PLAY/REJECT is input, a high pulse of 200ms is output.
17	PD3	POWER	The power code input inverts the L/H. Level is high for power being turned ON.



LA1266 (FM IF AND AM RADIO SYSTEM)

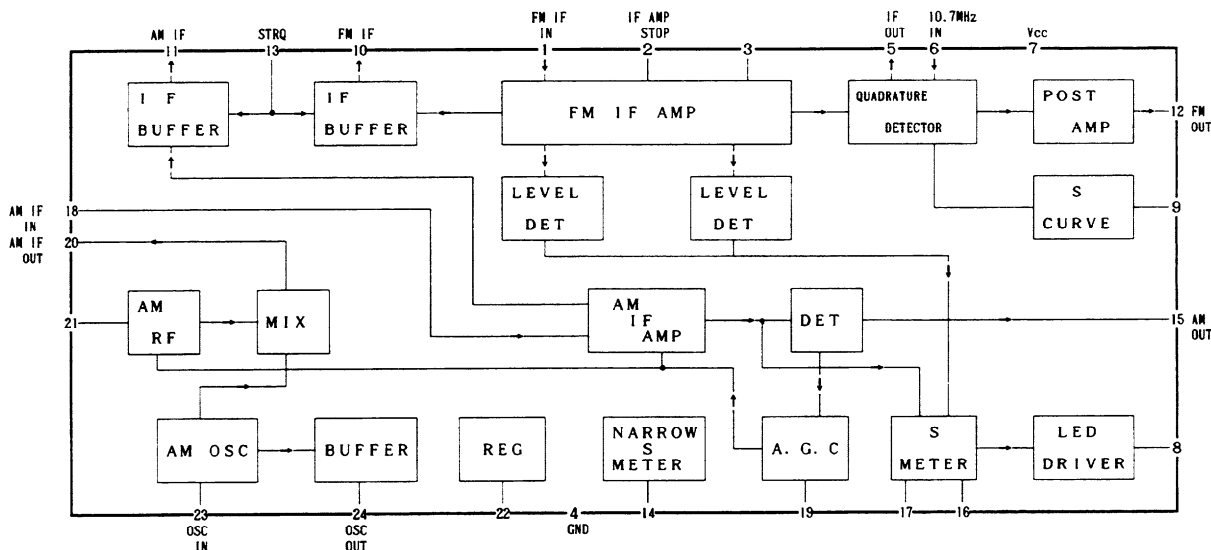

LB1630 (MOTOR DRIVE)

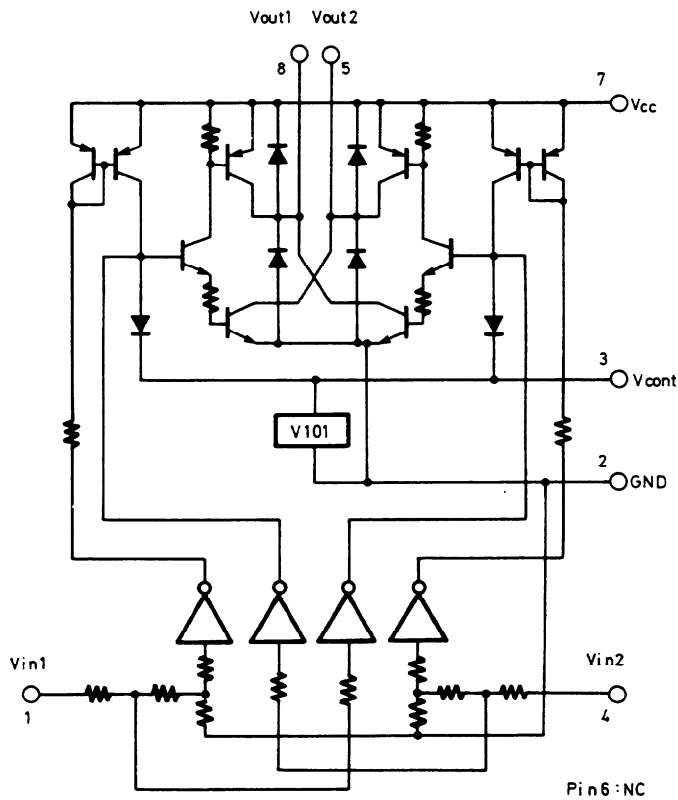

TRUTH TABLE

IN 1	IN 2	OUT 1	OUT 2	MOTOR
H	L	H	L	Normal
L	H	L	H	Reverse
H	H	OFF	OFF	Wait
L	L	OFF	OFF	Wait

NJM-4558D/4560D/DX (OP AMP)

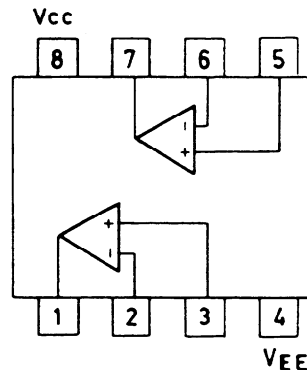

4066B (ANALOG SWITCH)

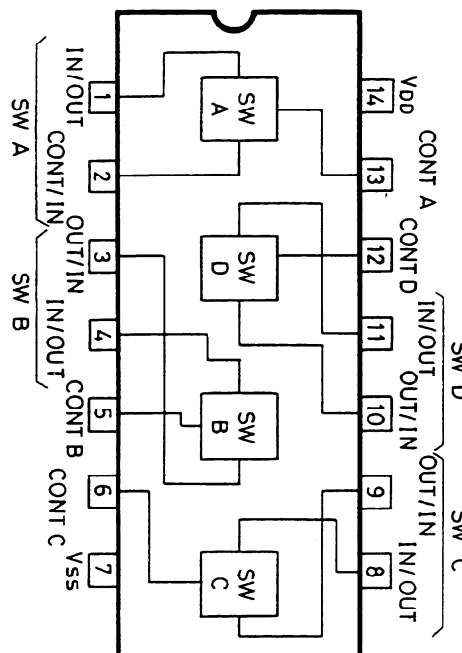

## ADJUSTMENT PROCEDURES

### Preparation

#### • Input

FM mono: 1kHz, 75kHz devi., 60dB/ $\mu$ V

FM stereo: 1kHz, L+R 67.5kHz devi.: Pilot signal 19kHz  
7.5kHz devi.

AM: 400Hz, 30% mod.,

#### • Output

Connect the non-inductive type resistor of 8 ohms to the speaker terminal A of left and right channels unless otherwise noted.

#### • Standard knob position

TAPE MONITOR .....	SOURCE
VOLUME .....	Maximum
BASS/TREBLE/BALANCE .....	Center
VCR 2 MODE .....	STEREO
SPEAKER .....	A
SIMULATED STEREO .....	OFF

### Amplifier section

#### 1. Idling current adjustment

Connect the DC voltmeter to the terminals IID and VCT on the power amplifier pc board.

Adjust the semi-fixed resistors R533 and R534 so that the indication of voltmeter is  $7.5 \pm 1.5$ mV.

Notes: VOLUME ..... Maximum, Open load,  
Adjust after switching on for 5 minutes.

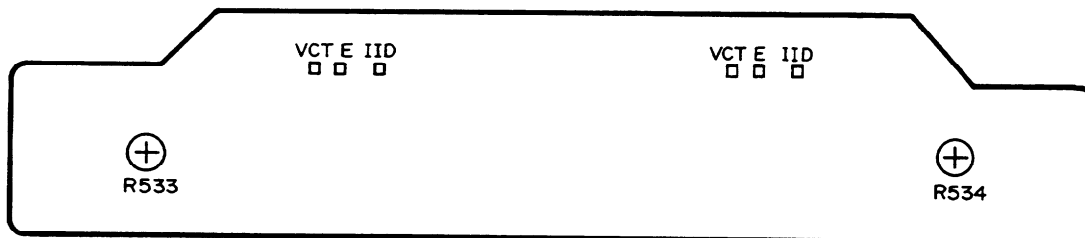

Power amplifier pc board

FM section

Item	Step	Connection of instrument	FM SG output	Stereo modulation output	Turning dial setting	Output indicator	Adjustment	Adjust for	Remarks
FM IF	1	Fig. 1	99.1MHz 1KHz, 75KHz devi. 65dB (60dB)	-	99.1MHz	DC voltmeter	L101	0V ± 20mV	Mode switch: MONO Repeat the steps 1 and 3 until no further adjustment is necessary
	2		99.1MHz 1KHz, 75KHz devi. 65dB (60dB)	-	99.1MHz	AC voltmeter	IF on the front end	Maximum	
	3		99.1MHz 1KHz, 75KHz devi. 65dB (60dB)	-	99.1MHz	Distortion analyzer	L102	Minimum	
Stereo indicator level	1	Fig. 3	99.1MHz 17.2dB (12dB) Ext. modulation	L + R : 1KHz 67.5KHz devi.	99.1MHz	Stereo indicator	R101	Light on	Mode switch: STEREO
	2		99.1MHz 16.2dB (11dB) Ext. modulation	Pilot signal 19KHz 7.5KHz devi.	99.1MHz	Frequency counter	R201	19KHz ± 10Hz	
VCO		Fig. 2	99.1MHz 1KHz, 75KHz devi. 65dB (60dB)	-	99.1MHz	Frequency counter	R201	19KHz ± 10Hz	
Stereo Distortion		Fig. 3	99.1MHz 65dB (60dB) Ext. modulation	L or R ch. 1KHz	99.1MHz	Distortion analyzer	IF on the front end	Minimum	Don't turn more than ± 180°.
	1		99.1MHz 65dB (60dB) Ext. modulation	Lch. 1KHz	99.1MHz	Rch. AC voltmeter	R201	Minimum	
Stereo Separation	1	Fig. 3	99.1MHz 65dB (60dB) Ext. modulation	Rch. 1KHz	99.1MHz	Lch. AC voltmeter	R201	Minimum	Maximum and same separation
	2		99.1MHz 35.2dB (30dB) 1KHz, 75KHz devi.	-	99.1MHz	Ht-blend indicator	R102	Light off	

AM section

Step	AM SG output	Tuned frequency	Output Indicator	Adjustment point	Adjust for
1		530KHz [522KHz] [531KHz]	Digital DC voltmeter	OSC on RF block	1.3V ± 0.1V
2	600Hz(603KHz) 60dB/m	600KHz (603KHz)	AC voltmeter	RF on RF block	Maximum
3	1000KHz (999KHz) 400Hz 30% mod. 60dB/m	1000KHz (999KHz)	AC voltmeter	L152	Maximum
4	Same as above	1000KHz (999KHz)	First signal indicator	R151	Light on

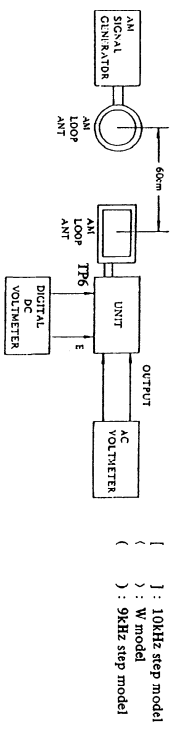

Reference specifications  
 FM Tuned voltage  
 87.9MHz 2.0 ± 0.5V  
 107.9MHz 7.7 ± 0.5V  
 (1.20V model)  
 87.5MHz 2.0 ± 0.5V  
 108.0MHz 7.7 ± 0.5V  
 (Other models)

Auto stop level  
 AM: Less than 66dB/m  
 FM: Less than 17dBμ

AM Tuned voltage  
 530KHz 1.3 ± 0.5V  
 1620KHz 8.0 ± 0.5V  
 (120V model)  
 522KHz 1.3 ± 0.5V  
 1611KHz 8.0 ± 0.5V  
 (Other models)

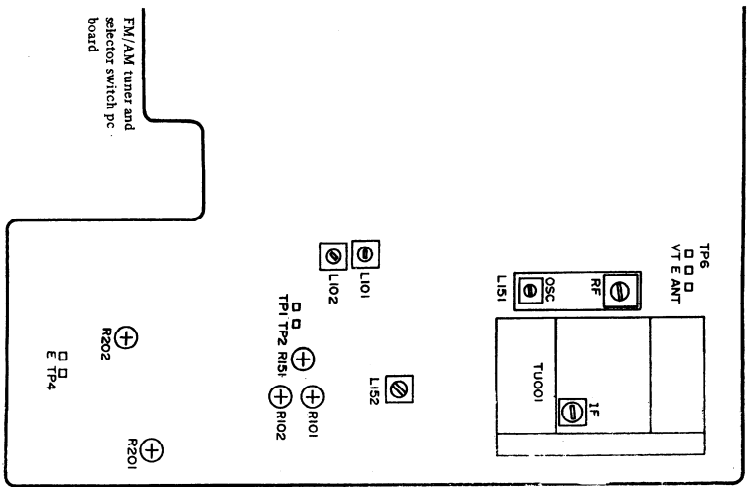
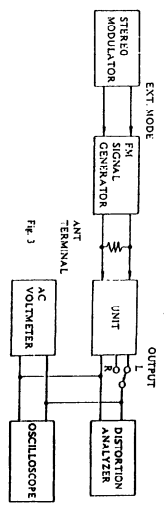
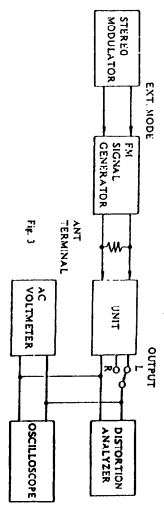
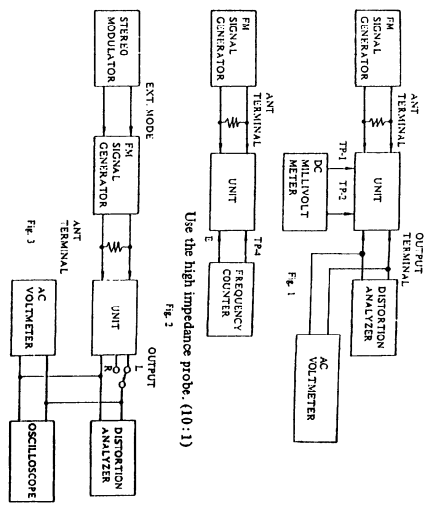

## PRINTED CIRCUIT BOARD-PARTS LIST

### DISPLAY PC BOARD(NADIS-3281-2/2A/2B)

CIRCUIT NO.	PART NO.	DESCRIPTION
U701	24130001	GPIU501S
Q701	22240153	LC6568H-3643
Q704	<del>22240150</del>	<del>LC6527C-3608</del>
<b>Transistors</b>		
Q702	2211255 or 2210746	2SC1815(GR) or 2SC945A(P)
Q705	2211455 or 2210803	2SA1015(GR) or 2SA733(P)
<b>Fluorescent tube</b>		
Q703	212054	7-BT-95GK
<b>Lamp</b>		
Q706	210064A	6.3V,0.25A
<b>Diodes</b>		
D702-D715	223163	1SS133
D716,D717	223163	1SS133 <G/W>
D718	224650822, 224150822 or 224450822	05AZ8.2Y or HZ8.2EB2 MTZ8.2B
D719	223163	1SS133
D720	224150562 or 224650562	05AZ5.6Y or HZ5.6EB2
D733-D735	223163	1SS133
<b>L.E.Ds</b>		
D723,D725	225137CG,	SEL2413ECG.
D727	225137DG or 224137DY	SEL2413EDG or SEL2413EDY
D724,D726	225142	SEL2913K
D728	225142	SEL2913K
D731	225141	SEL2213C
<b>Osc. elements</b>		
X701	3010099	CSA4.00MG,Ceramic

X702	3010119	CSB-1000D,Ceramic
<b>Capacitors</b>		
C702	3020027 or 3000051	0.047F,5.5V or 0.047F,5.5V,Super
C704	354780109	1 $\mu$ F,50V,Elect.
C707,C715	354782299	0.22 $\mu$ F,50V,Elect.
C708	354741009	10 $\mu$ F,16V,Elect.
<b>Resistors</b>		
R710	49163473404	47kohm $\times$ 4, 1/10W,Network
R734,R735	49163104404	100kohm $\times$ 4,1/10W,Network
<b>Switches</b>		
S701-S724	25035548	NPS-111-S510
S725	25065286	NSS-22112,Band <W>
<b>Relay</b>		
RL701	25065298	NRL-1P1A-DC12-40
<b>Holder</b>		
	27190643A	L.E.D

### SPEAKER TERMINAL PC BOARD(NASW-3279-1/1A)

CIRCUIT NO.	PART NO.	DESCRIPTION
P501,P502	25060110	NTM-4PDMN44,Speaker terminals

### PREAMPLIFIER PC BOARD(NAAF-3283-2/2A)

CIRCUIT NO.	PART NO.	DESCRIPTION
<b>ICs</b>		
Q352	222579 or 222570	NJM4560D or NJM4560DX
Q353	222465	NJM4558D

	<b>Transistors</b>	
Q851	2212600	DTA124ES
	<b>Capacitors</b>	
C359,C360	354780229	2.2 $\mu$ F,50V,Elect.
C363,C364	354741009	10 $\mu$ F,16V,Elect.
C367,C368	352983396	0.33 $\mu$ F,50V,Non-polar elect.
C373,C374	354780229	2.2 $\mu$ F,50V,Elect.
C375-C378	354781099	0.1 $\mu$ F,50V,Elect.
C389	354780229	2.2 $\mu$ F,50V,Elect.
C851	354780339	3.3 $\mu$ F,50V,Elect.
	<b>Resistors</b>	
R371,R372	5104216	N14RLC50KC22Z, Variable,Bass
R379,R380	5104216	N14RLC50KC22Z, Variable,Treble
R451	5104225	N11RGLC250KW22Z, Variable,Balance
	<b>Switch</b>	
S354	25035590	NPS-122-L552

**SPEAKER SWITCH PC BOARD(NASW-3278-2/2A)**

CIRCUIT NO.	PART NO.	DESCRIPTION
L501,L502	231001	S-1.3B,Coils
R549,R550	442520474	4.7ohm,1/2W,Metal oxide film resistors
R551,R552	441623914	390ohm,1W,Metal oxide film resistors
S502,S503	25035517	NPS-222-L479,Push switch
P503	25045187	HLJ-0541-01-010,Stereo headphone terminal <D/W>
	25045139	HLJ-0540-01-010,Stereo headphone terminal<G>

nals

**SPEAKER SWITCH PC BOARD**

NOTE: <D>: Only 120V model  
 <G>: Only 220V/240V models  
 <W>: Only Worldwide model



# SCHEMATIC DIAGRAM

## - AMPLIFIER SECTION - - 120V MODEL -

1 2 3 4 5 6 7

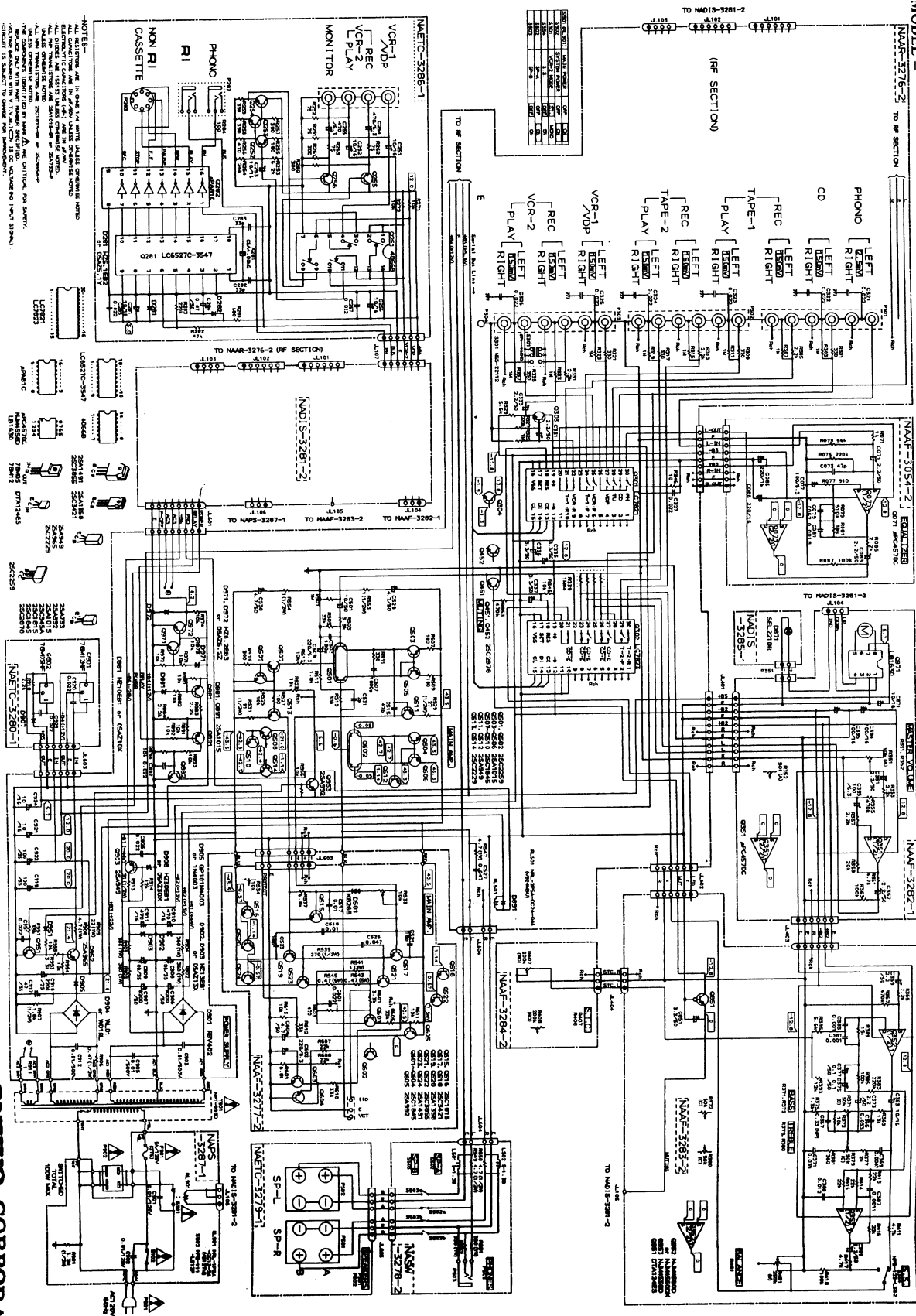

ONKYO CORPORATION

# SCHEMATIC DIAGRAM -AMPLIFIER SECTION-

220V MODEL

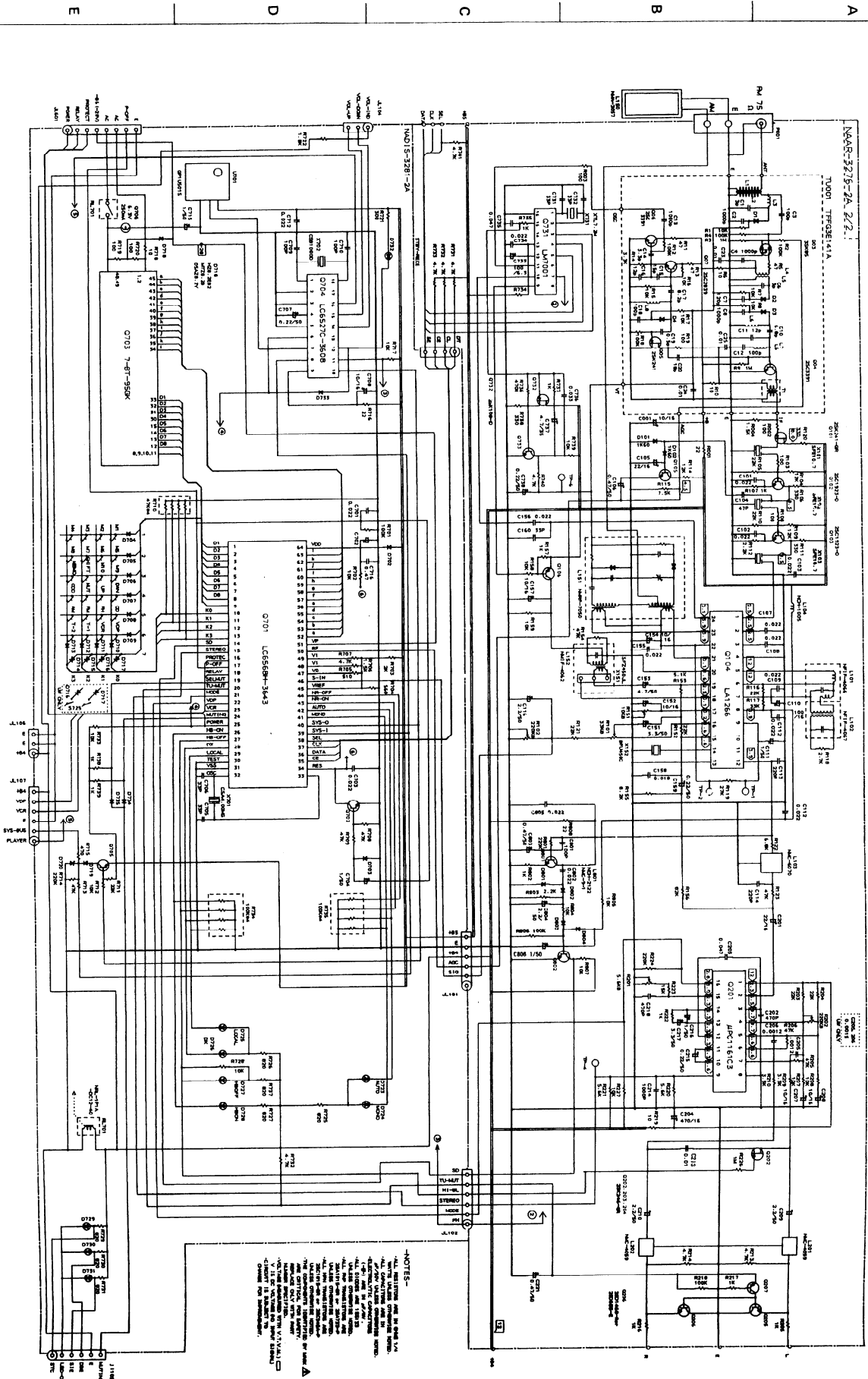





# PRINTED CIRCUIT BOARD-PARTS LIST

FM/AM TUNER AND SELECTOR CIRCUIT PC BOARD(NAAR  
-3276-2/2A/2B)

CIRCUIT NO.	PART NO.	DESCRIPTION	CIRCUIT NO.	PART NO.	DESCRIPTION
TU001	240070	TFFG1U116A <D>	L103	233383	NMC-6070 <G/W>
	240081	TFFG3E <G/W>	L104	233105	NCH-1005
		<b>ICs</b>	L201,L202	233355A	NMC-4059
Q104	22240039	LA1266	L801	231081 or	NCH-2129 or
Q201	222678	$\mu$ PC1161C3		233031	NMC-9-1
Q301	22240079	LC7821			<b>RF block</b>
Q302	22240158	LC7823	L151	232148	NMRF-7050
Q731	22240090	LM7001			<b>Ceramic filters</b>
		<b>Transistors</b>	X101,X102	3010071	SFE10.7MA5 (RED) <D>
Q101	2212195	2SK241(GR) <G/W>	X101-X103	3010137	SFE10.7MMK <G/W>
Q102	2211723	2SC1923(O)	X151	3010123	SFZ450JL
Q103	2211723	2SC1923(O) <G/W>	X152	3010076	BFU450C
Q105	2211255 or	2SC1815(GR) or			<b>X'tal</b>
	2210746	2SC945A(P)	X731	3010073	XTL-7.2M
Q106,Q207	2211455	2SA1015(GR)			<b>Capacitors</b>
Q202	2211945	2SK246(GR)	C001	354741009	10 $\mu$ F,16V,Elect.
Q205,Q206	2211705 or	2SD655(E) or	C105	354742209	22 $\mu$ F,16V,Elect.
	2212794	2SD1468(R)	C106	354784799	0.47 $\mu$ F,50V,Elect.
Q303,Q304	2211255 or	2SC1815(GR) or	C110	354741019	100 $\mu$ F,16V,Elect.
	2210746	2SC945A(P)	C111	354780109	1 $\mu$ F,50V,Elect.
Q451,Q452	2212285 or	2SC2878(A) or	C116	354780229	2.2 $\mu$ F,50V,Elect.
	2212286	2SC2878(B)	C151	354780339	3.3 $\mu$ F,50V,Elect.
Q501,Q502	2211371 or	2SC2259(O-001) or	C152	354741009	10 $\mu$ F,16V,Elect.
	2211372	2SC2259(O-002)	C153	354780479	4.7 $\mu$ F,50V,Elect.
Q503-Q506	2211455	2SA1015(GR)	C154,C157	354741009	10 $\mu$ F,16V,Elect.
Q507-Q510	2211732 or	2SC1845(F) or	C159	354782299	0.22 $\mu$ F,50V,Elect.
	2211733	2SC1845(E)	C201	354742209	22 $\mu$ F,16V,Elect.
Q511,Q512	2211353 or	2SA949(O) or	C204	354744719	470 $\mu$ F,16V,Elect.
	2211354	2SA949(Y)	C207,C208	354741009	10 $\mu$ F,16V,Elect.
Q513,Q514	2211633 or	2SC2229(O) or	C209,C210	354780229	2.2 $\mu$ F,50V,Elect.
	2211634	2SC2229(Y)	C215	354782299	0.22 $\mu$ F,50V,Elect.
Q732	2212294	2SK108(D)	C216	354780109	1 $\mu$ F,50V,Elect.
Q733,Q801	2211255 or	2SC1815(GR) or	C217	354780339	3.3 $\mu$ F,50V,Elect.
Q802,Q892	2210746	2SC945A(P)	C218	370134714	470pF $\pm$ 5%,100V,APS
Q881,Q891	2211455	2SA1015(GR)	C221	354784799	0.47 $\mu$ F,50V,Elect.
Q903	2211353 or	2SA949(O) or	C331-C334	354780229	2.2 $\mu$ F,50V,Elect.
	2211354	2SA949(Y)	C335-C337	354780339	3.3 $\mu$ F,50V,Elect.
Q951,Q971	2211255 or	2SC1815(GR) or	C501,C502	354781009	10 $\mu$ F,50V,Elect.
Q972	2210746	2SC945A(P)	<u>C509,C510</u>	<u>354722219</u>	220 $\mu$ F, 6.3V,Elect.
Q952	2211643 or	2SA965(O) or	C529,C530	354780479	4.7 $\mu$ F,50V,Elect.
	2211644	2SA965(Y)	C733	354721019	100 $\mu$ F, 6.3V,Elect.
Q953	2211792 or	2SA992(F) or	C737	354780479	4.7 $\mu$ F,50V,Elect.
	2211793	2SA992(E)	C738	354782299	0.22 $\mu$ F,50V,Elect.
		<b>Diodes</b>	C803	354784799	0.47 $\mu$ F,50V,Elect.
D101,D102	223132	1K60	C804	354780229	2.2 $\mu$ F,50V,Elect.
D801-D804	223163	1SS133	C806	354780109	1 $\mu$ F,50V,Elect.
D881	224651001 or	HZ10EB1 or	C903,C905	335251039A	0.01 $\mu$ F,500V,Ceramic
	224151001	05AZ10X	C906,C907	3504225	8200 $\mu$ F,50V,Elect.
D891	223163	1SS133	C908,C909	354761019	100 $\mu$ F,35V,Elect.
D901	22380022	RBV402	C910,C911	354744719	470 $\mu$ F,16V,Elect.
D902,D903	224151301 or	05ZA13X or	C912	335251039A	0.01 $\mu$ F,500V,Ceramic
	224651301	HZ13EB1	C917	354764709	47 $\mu$ F,35V,Elect.
D904	223862 or	WL01 or	C918	354762229	2200 $\mu$ F,35V,Elect.
	223890	W01RL	C919	354761019	100 $\mu$ F,35V,Elect.
D905	223880 or	GP101N4003 or	C921,C924	354741009	10 $\mu$ F,16V,Elect.
	223896	1N4003F	C922	354761019	100 $\mu$ F,35V,Elect.
D908	224153001 or	05AZ30X or			<b>Resistors</b>
	224653001	HZ30EB1	R101	5210067	N06HR33KBD,Semi-fixed
D951	223163	1SS133	R102	5210072	N06HR220KBD,Semi-fixed
D971,D972	224650623 or	HZ6.2EB3 or	R151	5210064	N06HR10KBD,Semi-fixed
	224150623	05AZ6.2Z	R201	5210062	N06HR4.7KBD,Semi-fixed
		<b>Transformers</b>	R202	5210072	N06HR220KBD,Semi-fixed
L101	233389	NFIF-4066	R339,R340	49163105404	1Mohm $\times$ 4,1/10W,Network
L102	233390	NFIF-4067	R529,R530	442522704	27ohm,1/2W,Metal oxide film
L152	232139	NMIF-4062	R531,R532	442529104	91ohm,1/2W,Metal oxide film

## POWER AMPLIFIER PC BOARD

CIRCUIT NO.	PART NO.	DESCRIPTION
R547,R548	441620474	4.7ohm,1W,Metal oxide film
R553,R554	442520104	1ohm,1/2W,Metal oxide film
R902-R905	441623614	360ohm,1W,Metal oxide film
R906	442524794	0.47ohm, 1/2W,Metal oxide film <D/W>
R907	442521824	1.8kohm,1/2W,Metal oxide film
R908	441620474	4.7ohm,1W,Metal oxide film
R909	441622204	22ohm,1W,Metal oxide film
R913	442529104	91ohm, 1/2W,Metal oxide film
<b>Relay</b>		
RL501	25065339	NRL-2P5A-DC24-046
<b>Terminals</b>		
P001	25060085	NTM-4PDMN29,Antenna <D>
	25060087	NTM-2PDMN31,Antenna <G/W>
P301-P303	25045213	NPJ-6PDBL-92
<b>Switch</b>		
S301	25065286	NPS-22112,VCR mode
<b>Sockets</b>		
P101,P102	25050270	NSCT-6P98
P402,P602	25050270	NSCT-6P98
P103	25050268	NSCT-4P96
P401	25050275	NSCT-11P103
P601	25050272	NSCT-8P100
<b>Fuse</b>		
F906	252070	1A-SE EAK,Secondary <G>
<b>Fuseholders</b>		
F906a	25050065	YSH403T <G>
<b>Radiator</b>		
	27160166	

NOTE: <D>: Only 120V model  
 <G>: Only 220V/240V models  
 <W>: Only Worldwide model

## POWER AMPLIFIER PC BOARD(NAAF-3277-2)

CIRCUIT NO.	PART NO.	DESCRIPTION
<b>Transistors</b>		
Q515,Q516	2211255	2SC1815(GR)
Q517,Q518	2212653 or 2212654	2SC3421(O) or 2SC3421(Y)
Q519,Q520	2212643 or 2212644	2SA1358(O) or 2SA1358(Y)
Q521,Q522 ☆	2201703, 2201704 or 2201706	2SC3855(O), 2SC3855(Y) or 2SC3855(P)
Q523,Q524 ☆	2201693, 2201694 or 2201696	2SA1491(O), 2SA1491(Y) or 2SA1491(P)

CAUTION: Replacement for transistor of mark ☆,if necessary,  
 must be made from the same beta group (HFE) as  
 the original type.

Ex. 2SC3855(O) 2SA1491(O)

Same beta group

Q601-Q604	2211732 or 2211733	2SC1845(F) or 2SC1845(E)
Q605	2211792 or 2211793	2SA992(F) or 2SA992(E)
<b>Diodes</b>		
D501,D502	4000120	KB265
<b>Capacitors</b>		
C603	354722219	220 $\mu$ F, 6.3V,Elect.
C604	354780479	4.7 $\mu$ F,50V,Elect.
<b>Resistors</b>		
R533,R534	5210064	N06HR10KBD,Semi-fixed
R539,R540	442522714	270ohm,1/2W,Metal oxide film
R541,R542	441720104	1ohm,2W,Metal oxide film
R543-R546	4000080 or 4500022	0.47ohm,5W,Metal plate
<b>Terminals</b>		
	25060118	NTM-1S52,For leg of power trans- istor

# PRINTED CIRCUIT BOARD-PARTS LIST

## VIDEO TERMINAL PC BOARD(NAETC-3286-1/1A)

CIRCUIT NO.	PART NO.	DESCRIPTION
	<b>ICs</b>	
Q251	222840661	4066B
Q281	22240145	LC6527C-3547
Q282	222807	$\mu$ PA81C
	<b>Transistors</b>	
Q252	2211455 or 2210803	2SA1015(GR) or 2SA733(P)
Q253-Q256	2211255 or 2210746	2SC1815(GR) or 2SC945A(P)
	<b>Diode</b>	
D281	224650512 224150512	HZ5.1EB2 or 05AZ5.1Y
D282	223163	1SS133
	<b>Osc. element</b>	
X281	3010099	CSA4.00MG,Ceramic
	<b>Capacitors</b>	
C251-C253	354741009	10 $\mu$ F,16V,Elect.
C254,C255	354724719	470 $\mu$ F,6.3V,Elect.
C256,C281	354741009	10 $\mu$ F,16V,Elect.
C284	354784799	0.47 $\mu$ F,50V,Elect.
	<b>Terminals</b>	
P251	25045216	NPJ-4PDBL94
P282	25045172	HSJ1003-01-020
	<b>Socket</b>	
P283	25050294	NSCT-8P121

## VOLUME PC BOARD(NAAF-3282-1/1A)

CIRCUIT NO.	PART NO.	DESCRIPTION
Q351	22240050	$\mu$ PC4570C,IC
Q871	222963	LB1630,IC
C351,C352	354780229	2.2 $\mu$ F,50V,Elect. capacitors
C355,C356	354721019	100 $\mu$ F,6.3V, Elect. capacitors
C357,C358	354780229	2.2 $\mu$ F,50V,Elect. capacitors
C394,C395	354741019	100 $\mu$ F,16V,Elect. capacitors
C871	354741009	10 $\mu$ F,16V,Elect. capacitor
R351,R352	5104234	N16RGM50KA30F,Variable resistor,Volume
P351	2000635A 25050270	NSAS-4P591,Socket NSCT-6P98,Socket

## VOLUME INDICATOR PC BOARD(NADIS-3285-1)

CIRCUIT NO.	PART NO.	DESCRIPTION
D871	225241 or 225242 27190545	SEL2210R-C or SEL2210R-D,LED Holder,LED

## CONST. VOLTAGE CIRCUIT PC BOARD(NAETC-3280-1)

CIRCUIT NO.	PART NO.	DESCRIPTION
Q901	222780125	NEC 78M12HF,IC
Q902	222780055	NEC 78M05HF,IC
D907	223163	1SS133,Diode

## SWITCH PC BOARD(NAAF-3284-2)

CIRCUIT NO.	PART NO.	DESCRIPTION
R407,R408	6182005	N25LGL200KRD10Z,Variable resistor

## EQUALIZER AMPLIFIER PC BOARD(NAAF-3054-2/3)

CIRCUIT NO.	PART NO.	DESCRIPTION
	<b>IC</b>	
Q071	22240191 or 222570	NJM4565DD or NJM4560DX
	<b>Elect. capacitors</b>	
C071,C072	354780229	2.2 $\mu$ F,50V
C077,C078	354721019	100 $\mu$ F,6.3V
C083,C084	354780229	2.2 $\mu$ F,50V
C085,C086	354742219	220 $\mu$ F,16V
	<b>Plug</b>	
P071	25055334	NPLG-9P317

NOTE: <D>: Only 120V model  
<G>: Only 220V/240V models  
<W>: Only Worldwide model

## POWER SUPPLY CIRCUIT PC BOARD(NAPS-3287-1/1A/1B/1C)

CIRCUIT NO.	PART NO.	DESCRIPTION
C901,C902	3500065A	DE7150FZ103PAC400V/125V, Capacitor IS
R901	431523355	3.3Mohm,1/2W,Solid resistor <D>
S902	<del>25035550</del>	NPS-111-L512P,Power
RL901	25065266 <del>25065248</del>	NRL-1P5A-DC12-36,Relay <D> NRL-1P15A-DC12-29,Relay <G/W>
F901a	250113	SN5051,Fuseholders <D/W>
F901	252050	5A(ST-6),Primary fuse <D/W>
F902a	25050065	YSH-403T,Fuseholders <G/W/Q>
F902	252075	2.5A-SE-EAK,Primary fuse <G/W/Q>
F903a	25050065	YSH-403T,Fuseholders <G>
F903	252075	2.5A-SE-EAK,Fuse for AC outlet <G>
	29360626-1	Label, fuse <D>

NOTE: <D>: Only 120V model  
<G>: Only 220V model  
<W>: Only Worldwide model  
<Q>: Only 240V model

NOTE: THE COMPONENTS IDENTIFIED BY MARK  $\Delta$  ARE CRITICAL FOR RISK OF FIRE AND ELECTRIC SHOCK. REPLACE ONLY WITH PART NUMBER SPECIFIED.

## DISASSEMBLING PROCEDURES

### 1. Top cover

Remove a screw (3TTS+8BQ(BC)) holding the top cover and the back panel.  
Remove the four screws (3TTS+8B(BC)) holding the back panel and the chassis.

### 2. Front panel

Remove the top cover.  
Remove the six screws (3TTP+8P(BC)) holding the front panel and the front basket.

### 3. Power amplifier pc board

Remove the top cover.  
Remove the five screws A.  
Cut the binder B.

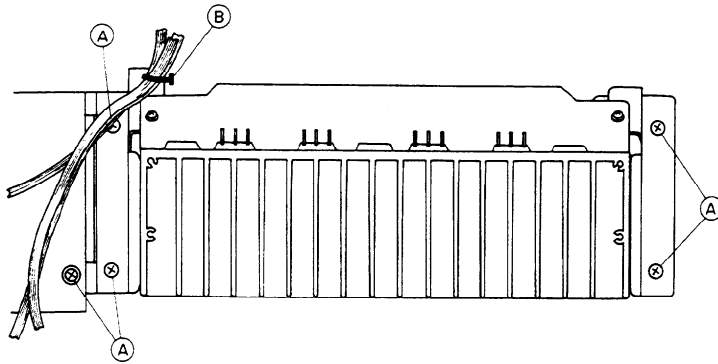

### 4. FM/AM tuner and selector switch pc board

Remove the top cover.  
Remove the three screws C holding the pc board and chassis.  
Remove the five screws D holding the back panel and chassis.  
Remove the pc board from the two holders.

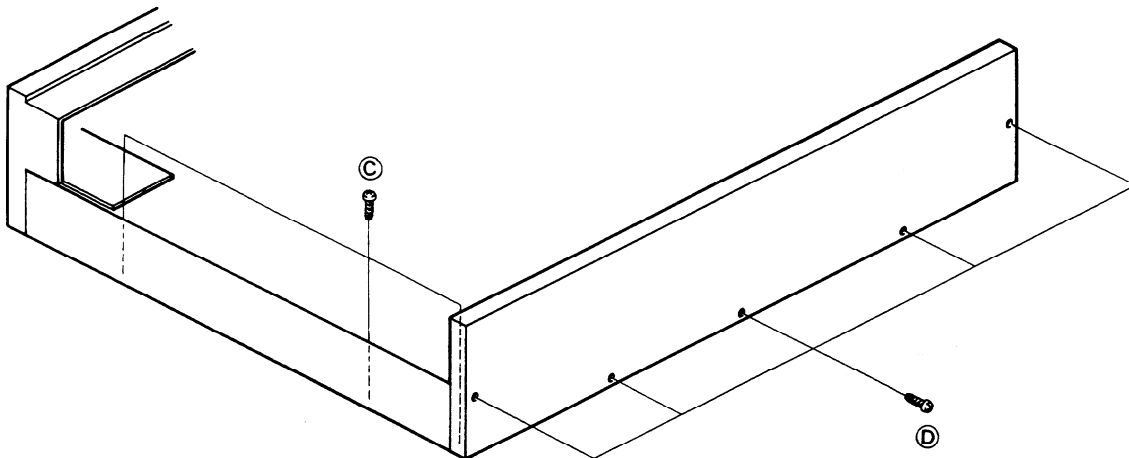

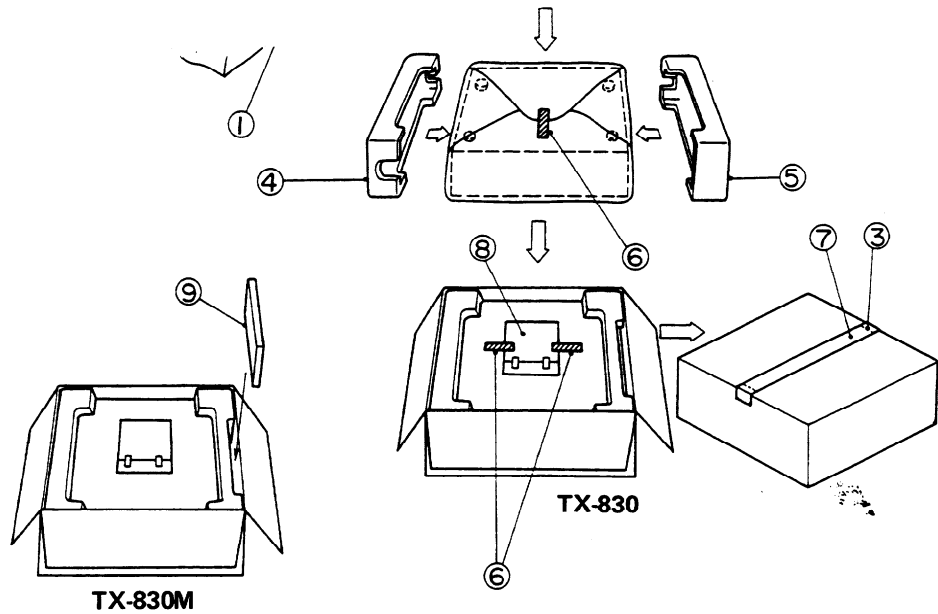

REF. NO.	PART NO.	DESCRIPTION
1	29100034	850×650mm, Poly-vinyl bag
	29095012-1	800×500mm, Protection sheet
2	29051692	Master carton box (TX-830)
	29051693	Master carton box (TX-830M)
3	282301	Sealing hook
4	29091263	Pad R
5	29091262	Pad L
6	29110032	Adhesive tape
7	260012	Damplon tape
8	Accessory bag ass'y	
	<b>-120V model-</b>	
	29341252	Instruction manual
	292064B	FM antenna
	232140	NMA-3057, AM loop antenna
	2010169	Connection cord for RI
	3010054	UM-3, Two batteries (TX-830)
		UM-3, Four batteries (TX-830M)
	24140021	RC-118S, Remote control transmitter (TX-850)
	29380091	Caution sheet (U.S.A. model)
	29100097	250×350mm, Poly-vinyl bag
	29365019	Warranty card (U.S.A. model)
	29358002F	Service station list (U.S.A. model)
		<b>-220V/240V models-</b>
	29341254	Instruction manual
	292092	FM antenna
	232140	NMA-3057, AM loop antenna
	2010169	Connection cord for RI
	3010054	UM-3, Two batteries
	24140025	RC-119S, Remote control transmitter
	29100097	250×350mm, Poly-vinyl bag
	25060123	FM adaptor (240V model)
		<b>-Worldwide model-</b>
	29341254	Instruction manual
	292092	FM antenna
	232140	NMA-3057, AM loop antenna
	2010169	Connection cord for RI
	3010054	UM-3, Two batteries
	24140025	RC-119S, Remote control transmitter
	29100097	250×350mm, Poly-vinyl bag
	25060123	FM adaptor
	25055018	CV-K-1, Conversion plug
	24140024	RC-AV10, Remote control transmitter (TX-830M)
	29341248	Instruction manual for remote control (Refer the service manual of RC-AV10M)

## ONKYO CORPORATION

International Division: No. 24 Mori Bldg., 23-5, Nishi-Shimbashi 3-chome, Minato-ku,  
 TOKYO 105. JAPAN Telex: 242-3551 ONKYO J. Tel. 03-432-6981  
**ONKYO U.S.A CORPORATION**  
 200 Williams Drive, Ramsey, N.J. 07446 Telex: 25-710-988-1033 Tel. 201-825-7950