

ONKYO SERVICE MANUAL

QUARTZ SYNTHESIZED TUNER AMPLIFIER MODELS TX-850/TX-850M

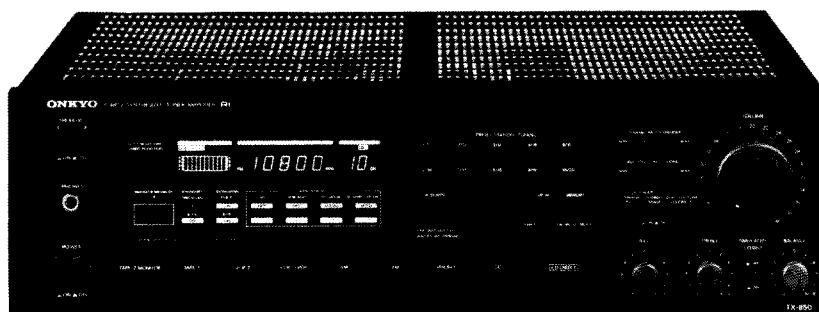

Black model

BHUD, BHUDN, MBHUDN	120V AC, 60Hz
BHUG	220V AC, 50Hz
BHUQA	240V AC, 50Hz
BHUW, MBHUWX	120/220V AC, 50/60Hz

SAFETY-RELATED COMPONENT WARNING!!

COMPONENTS IDENTIFIED BY MARK Δ ON THE SCHEMATIC DIAGRAM AND IN THE PARTS LIST ARE CRITICAL FOR RISK OF FIRE AND ELECTRIC SHOCK. REPLACE THESE COMPONENTS WITH ONKYO PARTS WHOSE PART NUMBERS APPEAR AS SHOWN IN THIS MANUAL.

MAKE LEAKAGE-CURRENT OR RESISTANCE MEASUREMENTS TO DETERMINE THAT EXPOSED PARTS ARE ACCEPTABLY INSULATED FROM THE SUPPLY CIRCUIT BEFORE RETURNING THE APPLIANCE TO THE CUSTOMER.

TABLE OF CONTENTS

Specifications	2
Service procedures	3
Exploded view	4
Parts list	5
Block diagram -120V model-	6
Block diagram -220V model-	8
Connection diagram of microprocessor	10
Block diagram of IC	11
Adjustment procedures	18
Pc board view/parts list	
Display/preamp./speaker	21
AM/FM tuner and selector circuit	25
Power amplifier	30
Other pc boards	33
Schematic diagram	
120V model -Tuner-	23
120V model -Amp.-	27
Other models -Tuner-	31
Other models -Amp.-	35
Disassembling procedures	37
Packing view	38

ONKYO

AUDIO COMPONENTS

SPECIFICATIONS

AMPLIFIER SECTION

Power output:	68 watts per channel, min, RMS, at 8ohms, both channels driven from 20Hz to 20kHz, with no more than 0.04% total harmonic distortion.	
Musical Power Output:	2×175 watts at 4 ohms, 1kHz (DIN) 2×110 watts at 8 ohms, 1kHz (DIN)	
Continuous Power Output:	2×100 watts at 4 ohms, 1kHz (DIN) 2×75 watts at 8 ohms, 1kHz (DIN)	
Total Harmonic Distortion:	0.04% at rated power 0.04% at 1 watts output	
IM Distortion:	0.04% at rated power 0.04% at 1 watts output	
Damping Factor:	40 at 8 ohms	
Frequency Response:	20-30,000Hz ±1dB	
RIAA Diviation:	20-20,000Hz ±0.8dB	
Sensitivity and Impedance:	Phono:	2.5mV/50 kohms
	CD:	150mV/50 kohms
	Tape Play:	150mV/50 kohms
	Tape Rec:	150mV/3.5 kohms
Phono Overload(MM):	120mV RMS at 1kHz, 0.04% THD.	
Signal-to-Noise Ratio:	Phono:	85dB(at 10mV input, A weighted) 75dB(IHF A-202)
	CD/Tape:	95dB(A weighted) 80dB(IHF A-202)
Tone controls:	Bass:	±10dB at 100Hz
	Treble:	±10dB at 10kHz

TUNER SECTION

FM:

	-220V/240V/ Worldwide models-	-120V model-
Tuning Range:	87.50-108.00MHz(50kHz steps) 87.50 108.00MHz(50kHz steps) or 87.9-107.9kHz(200kHz steps) (Worldwide model)	87.9-107.9kHz(200kHz steps)
Usable Sensitivity:	Mono: 11.2dBf, 1.0 μV, 75ohms 0.9 μV(S/N 26dB, 40kHz Devi.) 75ohms DIN Stereo: 18.0dBf, 2.2 μV, 75ohms 23μV(S/N 46dB, 40kHz Devi.) 75ohms DIN	Mono: 10.8dBf, 1.9μV Stereo: 17.2dBf, 4.0 μV
50dB Quieting Sensitivity:	Mono: 18.0dBf, 2.2 μV, 75ohms Stereo: 37.2dBf, 20μV, 75ohms	Mono: 17.2dBf, 4.0 μV Stereo: 37.2dBf, 40μV
Capture Ratio:	1.5dB	1.5dB
Image Rejection Ratio:	85dB	40dB
IF Rejection Ratio:	90dB	90dB
Signal-to-Noise Ratio:	Mono: 73dB Stereo: 67dB	Mono: 73dB Stereo: 67dB
Alternate Channel Attenuation:		55dB
Selectivity:	50dB DIN(±300kHz, 40kHz dev.)	
AM suppression Ratio:	50dB	50dB
Harmonic Distortion:	Mono: 0.15% Stereo: 0.25%	Mono: 0.15% Stereo: 0.25%
Frequency Response:	30 15,000Hz ±1.5dB	30 15,000Hz ±1.5dB
Stereo Separation:	45dB at 1kHz 30dB at 100-10,000Hz	45dB at 1kHz 30dB at 100-10,000Hz
Muting Level:	17.2dBf, 4.0μV	17.2dBf, 4.0μV
AM:		
Tuning Range:	522 1611kHz(9kHz steps) 522 1611kHz(9kHz steps) or 530-1620kHz(10kHz steps) (Worldwide model)	530-1620kHz(10kHz steps)
Usable Sensitivity:	30μV	30μV
Image Rejection Ratio:	40dB	40dB
IF Rejection Ratio:	40dB	40dB
Signal-to-Noise Ratio:	40dB	40dB
Harmonic Distortion:	0.7%	0.7%

GENERAL

Dimensions(W×H×D):	435×130×351mm 17-1/8" ×5-1/8" ×13-13/16"
Weight:	8.8kg., 19.4lbs.

REMOTE CONTROL TRANSMITTER RC-119S/RC-118S

Transmitter:	Infrared
Signal range:	Approx. 5meters(16ft.4")
Power supply:	TWO "AA" batteries (1.5V×2)
Dimensions(W×H×D):	64×18×176mm 2-1/2" × 3/4" × 7"
Weight:	140grams 5.0oz.(including batteries)

Specifications and features are subject to change without notice.

SERVICE PROCEDURES**1. Replacing the fuses**

For continued protection against fire hazard, replace only with same type and same rating fuse.

D (120V) model

Circuit no.	Part no.	Description
F901	252050	5 A (ST-6), Primary

G (220V) and Q (240V) models

Circuit no.	Part no.	Description
F902	252075	2.5A-SE-EAK, Primary
F903	252075	2.5A-SE-EAK, AC outlet (Only 220V model)

F906	252070	1A-SE-EAK, Secondary
------	--------	----------------------

W (Worldwide) model

Circuit no.	Part no.	Description
F901	252050	5 A (ST-6), Primary
F902	252075	2.5A-SE-EAK, Primary

2. Change of FM/AM band step.

With the exception of the models below, a BAND STEP selector switch is not provided.

(FM)

MODEL	BAND STEP	D717, J753	R119
UD	200kHz→50kHz	Additional	15kΩ→24kΩ
UG/UQ	50kHz→200kHz	Eliminated	24kΩ→15kΩ

(AM)

BAND STEP	D716, J754
10kHz→9kHz	Additional
9kHz→10kHz	Eliminated

In D716/7 1SS133 (Part No. 223163) is used. In J753/4, a jumper lead must be inserted. R119, with the muting amplitude determined, is on the back panel side of FM/AM tuner and selector circuit printed circuit board assembly test points TP-1 and TP-2.

— Worldwide model —

Worldwide models are equipped with a step band selector switch. This switch is located on the back panel. This switch is set to 50kHz (FM) and 9kHz (AM) at the factory, but may have to be reset to 200kHz and 10kHz depending on the area where the unit is used.

	De-emphasis	FM step	AM step
Europe:	50 μsec	50kHz	9kHz
U.S.A.:	75 μsec	200kHz	10kHz

3. Memory preservation

This unit does not require memory preservation batteries. A built-in memory power back-up system preserves contents of the memory during power failures and even when the unit is unplugged. The unit must be plugged in

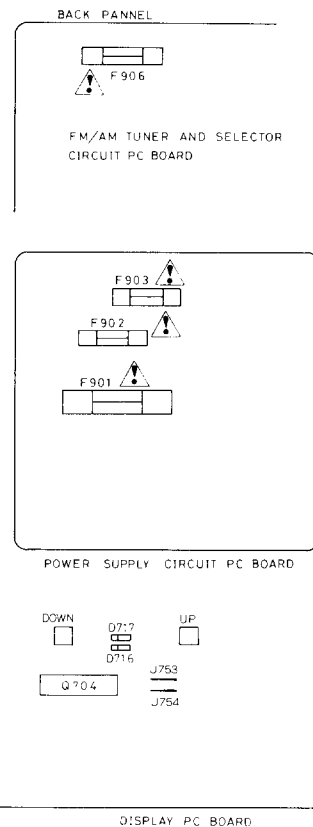

and the power switch turned on and off once in order to charge the back-up system. Note that since this is not a permanent memory the power switch must be turned on and off a few times each month to keep the back-up system operative. The period of time during which memory contents are preserved after power has last been turned off varies depending on climate and placement of the unit. On the average, memory contents are protected over a period of 3 to 4 weeks (a minimum of 2 weeks) after the last time power has been turned off. This period is shorter when the unit is exposed to very high humidity or used in an area with an extremely humid climate.

4. Safety-check out

(Only U.S.A. model)

After correcting the original service problem perform the following safety check before releasing the set to the customer.

Connect the insulating-resistance tester between the plug of power supply cord and terminal GND on the back panel. Specifications: 3.3 Mohm ±10% at 500V.

5. Change of voltage

Worldwide models are equipped with a voltage selector to conform with local power supplies. This switch is located on the back panel. Be sure to set this switch to match the voltage of the power supply in your area before turning the power switch on.

This switch is set to 220V at the factory. Voltage is changed by sliding the groove in the switch with the screwdriver to the right or left. Confirm that the switch has been moved all the way to the right or left before turning the power switch on.

EXPLODED VIEW

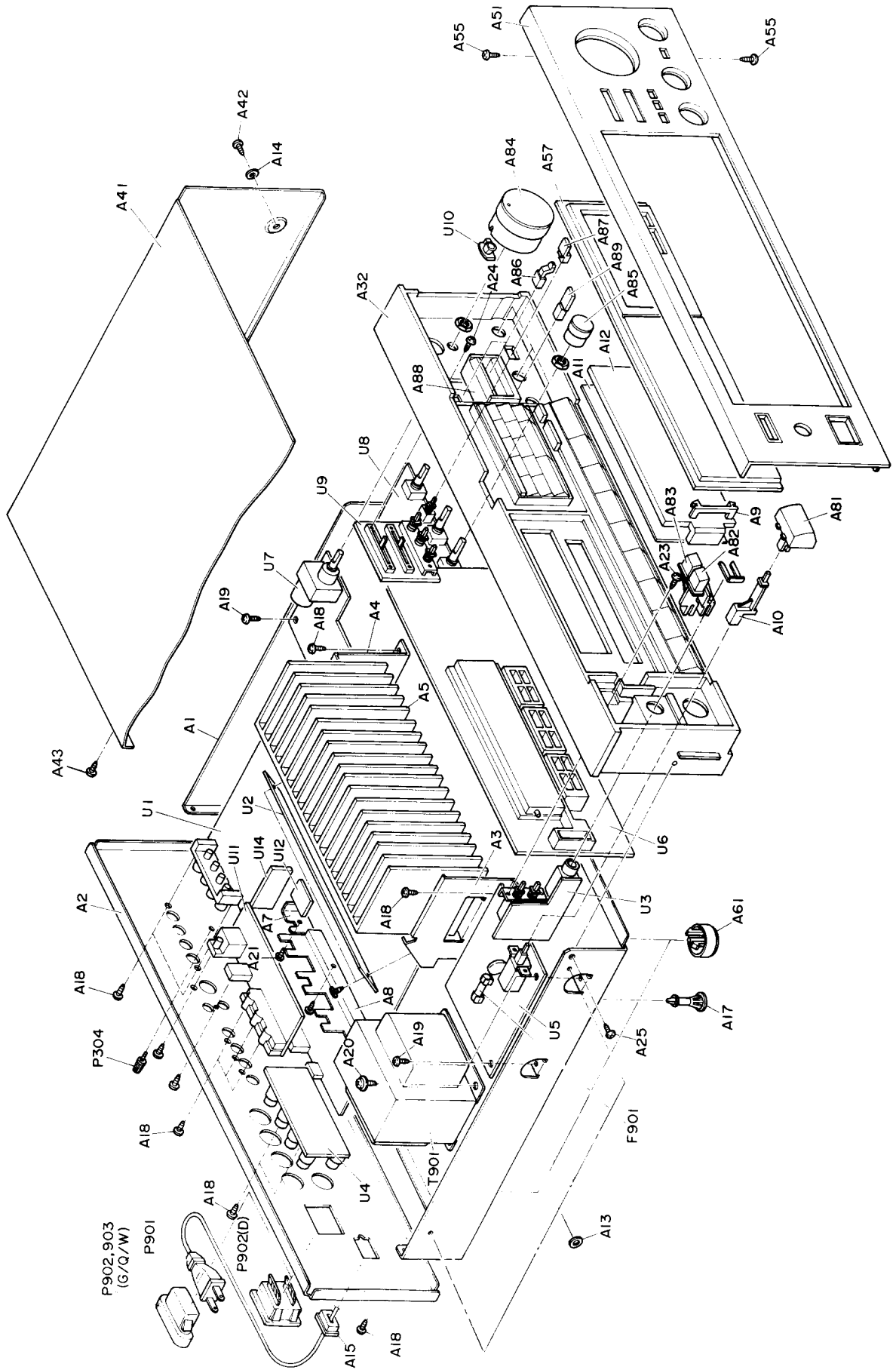

PARTS LIST

REF. NO.	PART NO.	DESCRIPTION	REF. NO.	PART NO.	DESCRIPTION
A1	27100163	Chassis	F903	252075	△ 2.5A-SE-EAK,AC outlet fuse <G>
A2	27121106	Back panel <D>	F906	252070	△ 1A-SE-EAK,Secondary fuse <G/Q>
	27121107	Back panel <G>	P304	25060044	3×14mm,Terminal GND
	27121109	Back panel <W>	P901	253123,	△ AS-UC-6 # 18,Power supply cord
	27121110	Back panel <PX>		253136,	<D/PX>
	27121111	Back panel <Q>		253140 or	
A3	27141261A	Bracket LH		253146	
A4	27141262	Bracket RH		253148 or	△ AS-CEE,Power supply cord <G/W>
A5	27160225	Radiator		253150	
A7	27141263	Bracket SH		253118	△ AS-SAA,Power supply cord <Q>
A8	27141264	Bracket H	P902	25050341	△ NSCT-4P168T,AC outlet <D/PX>
A9	27190644	Holder,dial plate	P902,P903	25050337	△ NSCT-2P164,AC outlet <G/W>
A10	27273098A	Joint,power	Q521,Q522	2501653,	2SC3856(O),
A11	28133198A	Back plate		2201654 or	2SC3856(Y) or
A12	28130249	Dial plate		2201655	2SC3856(P),Power amplifier transister
A13	27270147	Spacer	Q523,Q524	2201663,	2SA1492(O),
A14	870048	3 × 8×0.8t,Nylon washer		2201664 or	2SA1492(Y) or
A15	27300750	△ Strainrelief		2201665	2SA1492(P),Power amplifier transister
A17	27190524	Holder	S903	25065123	△ NPS-1258P,Voltage selector switch <W>
A18	834430088	3TTS+8B(BC),Tapping screw	T901	2300303	△ NPT-992D,Power transformer <D>
A19	831130088	3TTW+8B,Tapping screw		2300304	△ NPT-992G,Power transformer <G>
A20	830440089	4TTC+8C(BC),Tapping screw		2300305	△ NPT-992DG,Power transformer <W/PX>
A21	834430108	3TTS+10B(BC),Tapping screw	U1	2300339	△ NPT-992Q,Power transformer <Q>
A22	834230108	3TTS+10B(Ni),Nickel screw		1A090576-1	NAAR-3276-1,FM/AM tuner and selector circuit pc board ass'y <D>
A23	82143006	3P+6F(N(BC),Pan head screw		1A090576-1A	NAAR-3276-1A, FM/AM tuner and selector circuit pc board ass'y <G/Q>
A24	82142004	2P+4F(BC),Pan head screw	U2	1A091576-1B	NAAR-3276-1B, FM/AM tuner and selector circuit pc board ass'y <W/PX>
A25	833430080	3TTP+8P(BC),Tapping screw	U3	1A090577-1	NAAF-3277-1,Power amplifier pc board ass'y
A32	27110418A	Front bracket ass'y	U3	1A090578-1	NASW-3278-1,Speaker switch pc board ass'y <D/W/PX>
A41	28184394	Top cover	U4	1A090578-1A	NASW-3278-1A, Speaker switch pc board ass'y <G/Q>
A42	834430088	3TTS+8B(BC),Tapping screw		1A090579-1	NAETC-3279-1,Speaker terminal pc board ass'y <D>
A43	801230	3STS+8BQ(BC),Tapping screw		1A090579-1A	NAETC-3279-1A, Speaker terminal pc board ass'y <G/W/PX/Q>
A51	1A091121	Front panel ass'y			
A55	833430080	3TTP+8P(BC),Tapping screw			
A57	28191466A	Clear plate			
A61	27175142	Leg			
A81	28323241	Knob POWER			
A82	28323361	Knob SPEAKER A			
A83	28323363	Knob SPEAKER B			
A84	28323365A	Knob VOLUME			
A85	28323310	Knob TONE			
A86	28322925	Knob SLIDE			
A87	28323367	Knob PUSH			
A88	27190647	Knob SLIDE			
A89	28323369	Knob PUSH			
F901	252050	△ 5A(ST-6),Primary fuse <D/W/PX>			
F902	252075	△ 2.5A-SE-EAK,Primary fuse <G/W/PX/Q>			
U5	1A090580-1	NAETC-3280-1,Const. voltage circuit pc board ass'y	U5	1A090580-1	NAETC-3280-1,Const. voltage circuit pc board ass'y
U6	1A090581-1	NADIS-3281-1,Display pc board ass'y <D>	U6	1A090581-1	NADIS-3281-1,Display pc board ass'y <D>
	1A090581-1A	NADIS-3281-1A, Display pc board ass'y <G/Q>		1A090581-1A	NADIS-3281-1A, Display pc board ass'y <G/Q>
	1A091581-1B	NADIS-3281-1B, Display pc board ass'y <W/PX>		1A091581-1B	NADIS-3281-1B, Display pc board ass'y <W/PX>
U7	1A090582-1	NAAF-3282-1,Volume pc board ass'y <D>	U7	1A090582-1	NAAF-3282-1,Volume pc board ass'y <D>
	1A090582-1A	NAAF-3282-1A, Volume pc board ass'y <G/W/PX/Q>		1A090582-1A	NAAF-3282-1A, Volume pc board ass'y <G/W/PX/Q>
U8	1A090583-1	NAAF-3283-1,Preampfier pc board ass'y <D>	U8	1A090583-1	NAAF-3283-1,Preampfier pc board ass'y <D>
	1A090583-1A	NAAF-3283-1A, Preampfier pc board ass'y <G/W/PX/Q>		1A090583-1A	NAAF-3283-1A, Preampfier pc board ass'y <G/W/PX/Q>
U9	1A090584-1	NAAF-3284-1,Switch pc board ass'y	U9	1A090584-1	NAAF-3284-1,Switch pc board ass'y
U10	1A090585-1	NADIS-3285-1,Volume indicator pc board ass'y	U10	1A090585-1	NADIS-3285-1,Volume indicator pc board ass'y
U11	1A090586-1	NAETC-3286-1,Video terminal pc board ass'y <D/PX>	U11	1A090586-1	NAETC-3286-1,Video terminal pc board ass'y <D/PX>
	1A090586-1A	NAETC-3286-1A, Video terminal pc board ass'y <G/W/Q>		1A090586-1A	NAETC-3286-1A, Video terminal pc board ass'y <G/W/Q>
U12	1A090587-1	NAPS-3287-1,Power supply circuit pc board ass'y <D>	U12	1A090587-1	NAPS-3287-1,Power supply circuit pc board ass'y <D>
	1A090587-1A	NAPS-3287-1A,Power supply circuit pc board ass'y <G>		1A090587-1A	NAPS-3287-1A,Power supply circuit pc board ass'y <G>
	1A091587-1B	NAPS-3287-1B,Power supply circuit pc board ass'y <W/PX>		1A091587-1B	NAPS-3287-1B,Power supply circuit pc board ass'y <W/PX>
	1A091587-1C	NAPS-3287-1C,Power supply circuit pc board ass'y <Q>		1A091587-1C	NAPS-3287-1C,Power supply circuit pc board ass'y <Q>
U14	1A073554-2	NAAF-3054-2,Equalizer amplifier pc board ass'y <D>	U14	1A073554-2	NAAF-3054-2,Equalizer amplifier pc board ass'y <D>
	1A086554-3	NAAF-3054-3,Equalizer amplifier pc board ass'y <G/W/PX/Q>		1A086554-3	NAAF-3054-3,Equalizer amplifier pc board ass'y <G/W/PX/Q>

NOTE: <D>: Only 120V model
<G>: Only 220V model
<W>: Only Worldwide model
<PX>: Only PX model
<Q>: Only 240V model

NOTE: THE COMPONENTS IDENTIFIED BY MARK△ ARE CRITICAL FOR RISK OF FIRE AND ELECTRIC SHOCK. REPLACE ONLY WITH PART NUMBERS SPECIFIED.

BLOCK DIAGRAM

-120V MODEL- TUNER SECTION

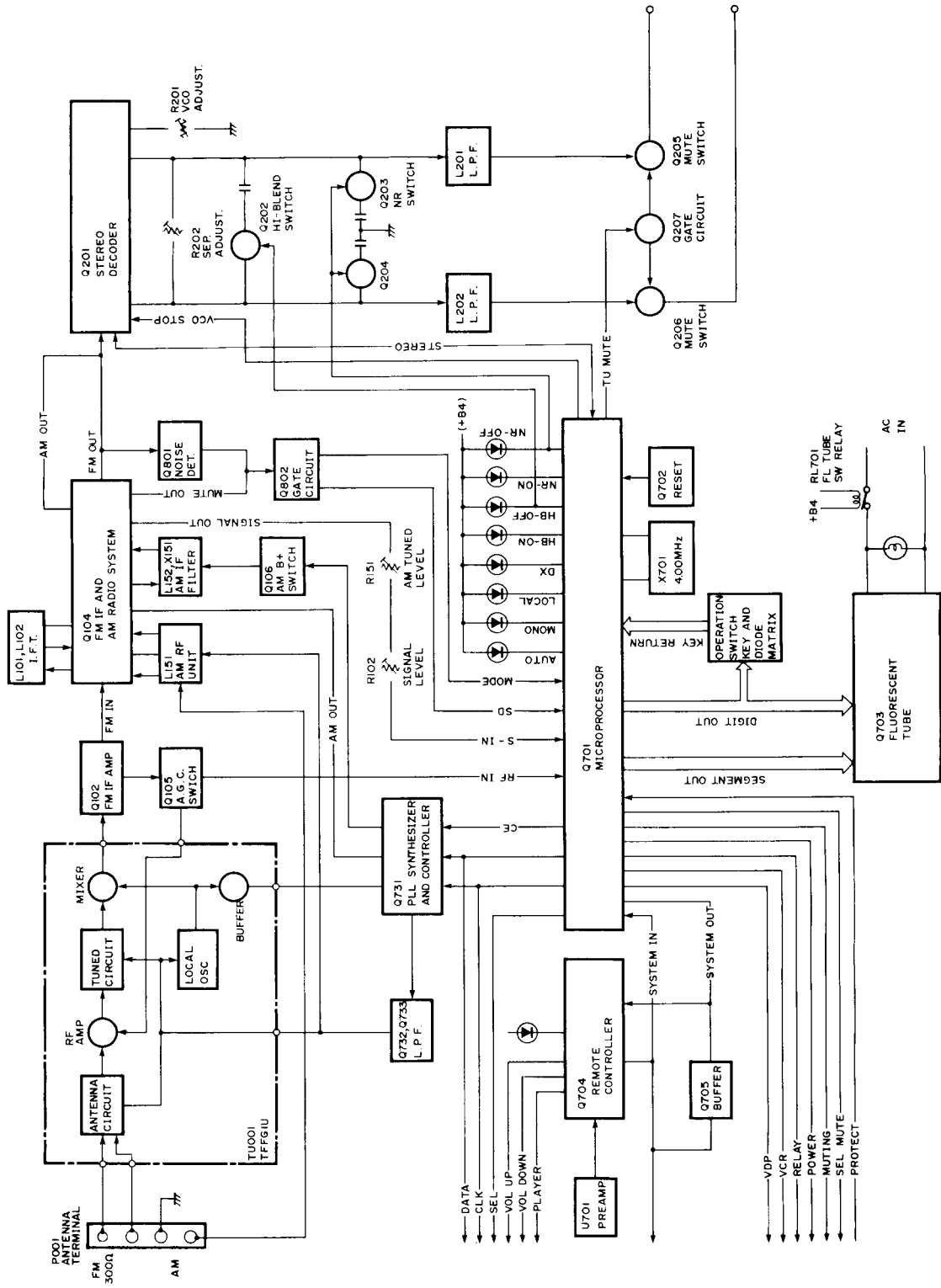

AMPLIFIER SECTION

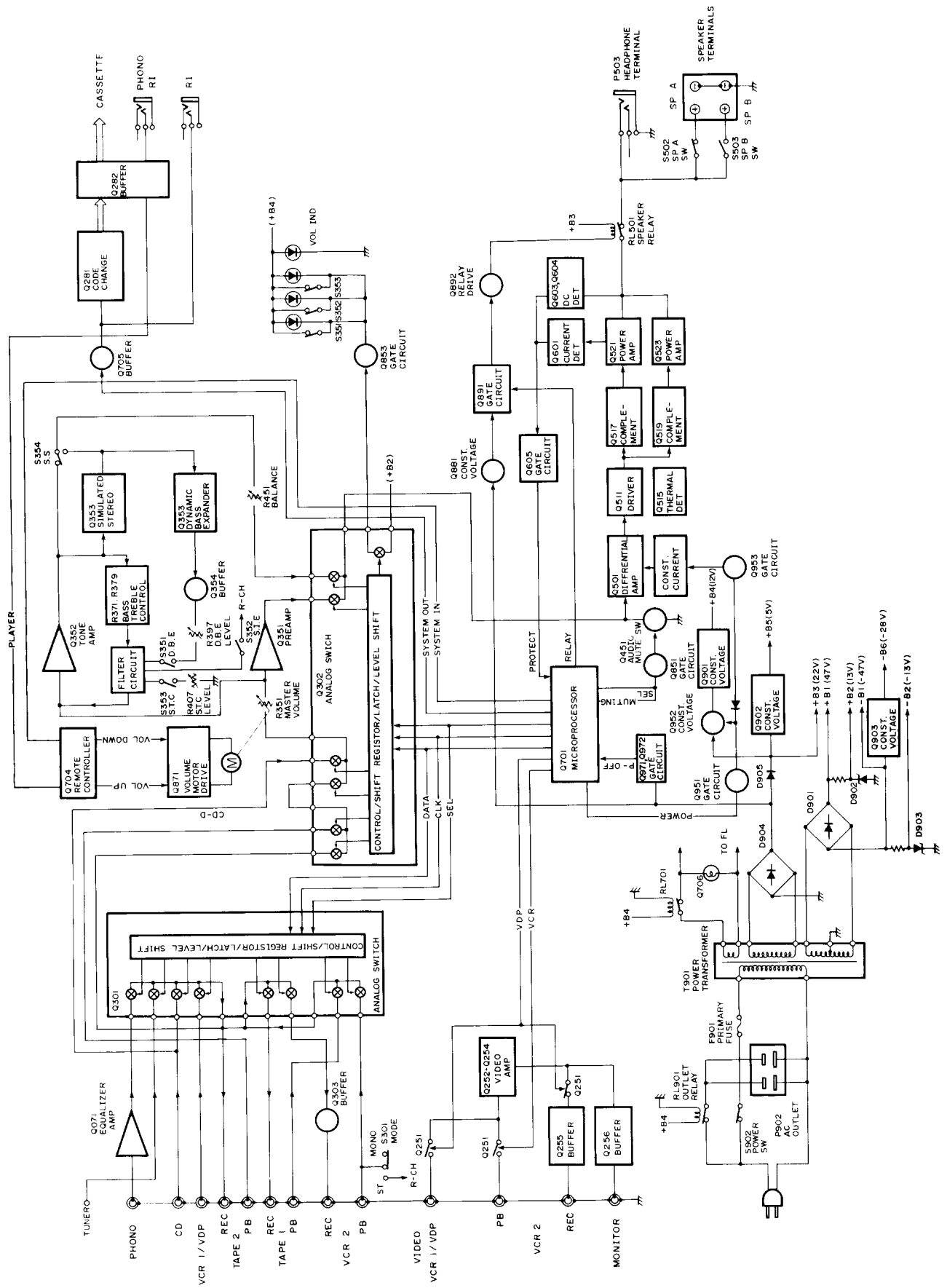

BLOCK DIAGRAM

—OTHER MODELS—
TUNER SECTION

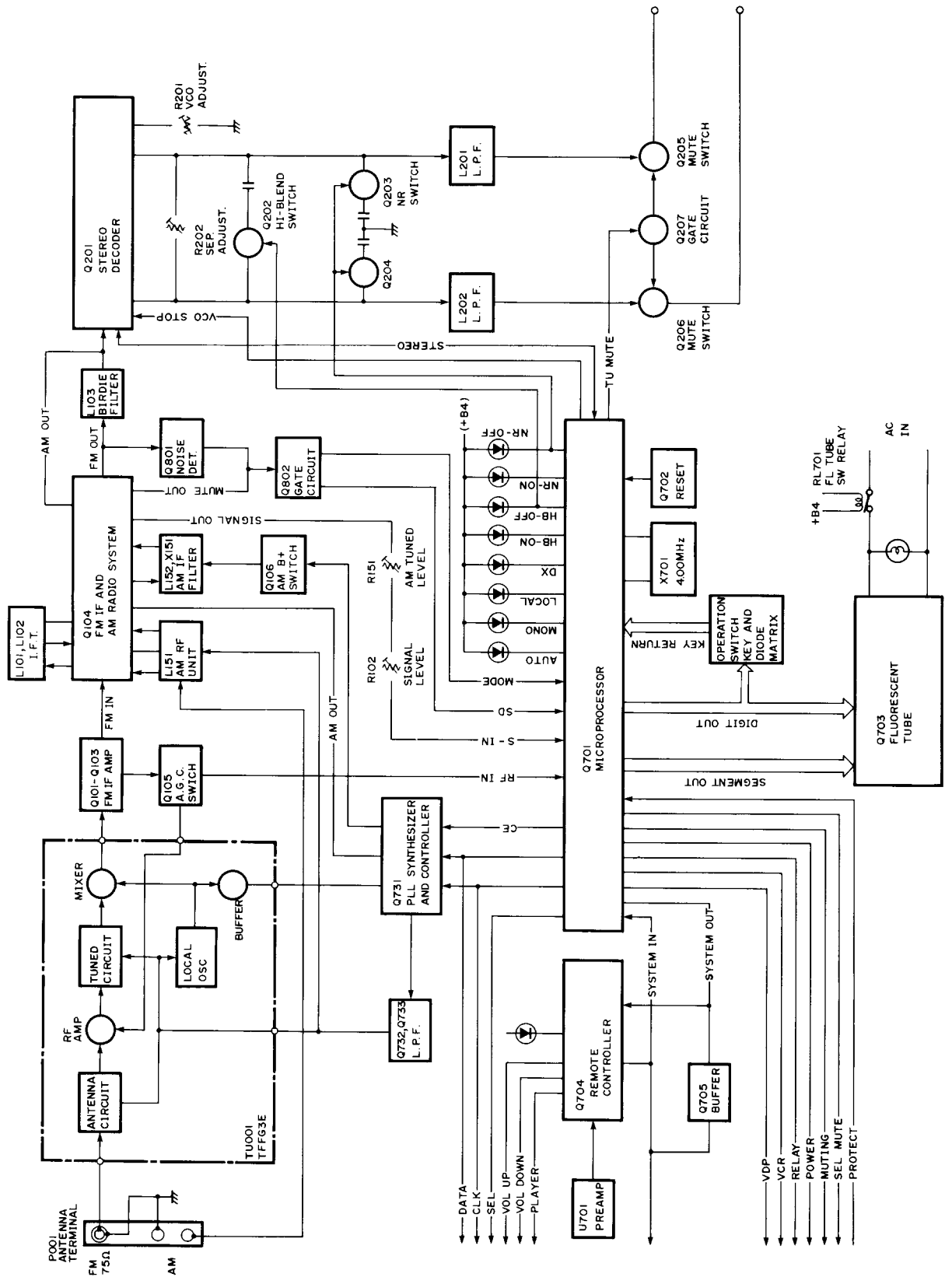

AMPLIFIER SECTION

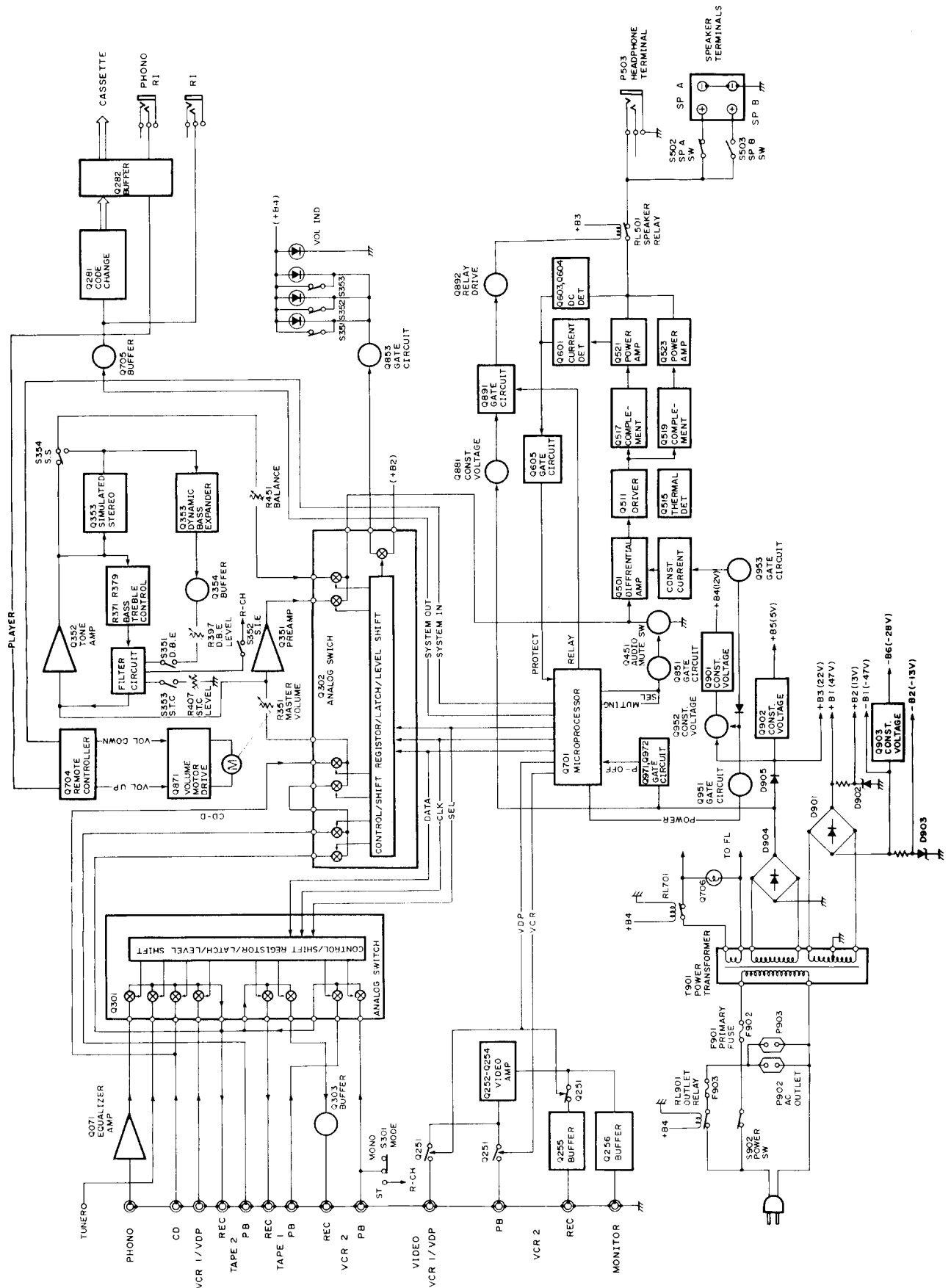

CONNECTION VIEW OF MICROPROCESSOR

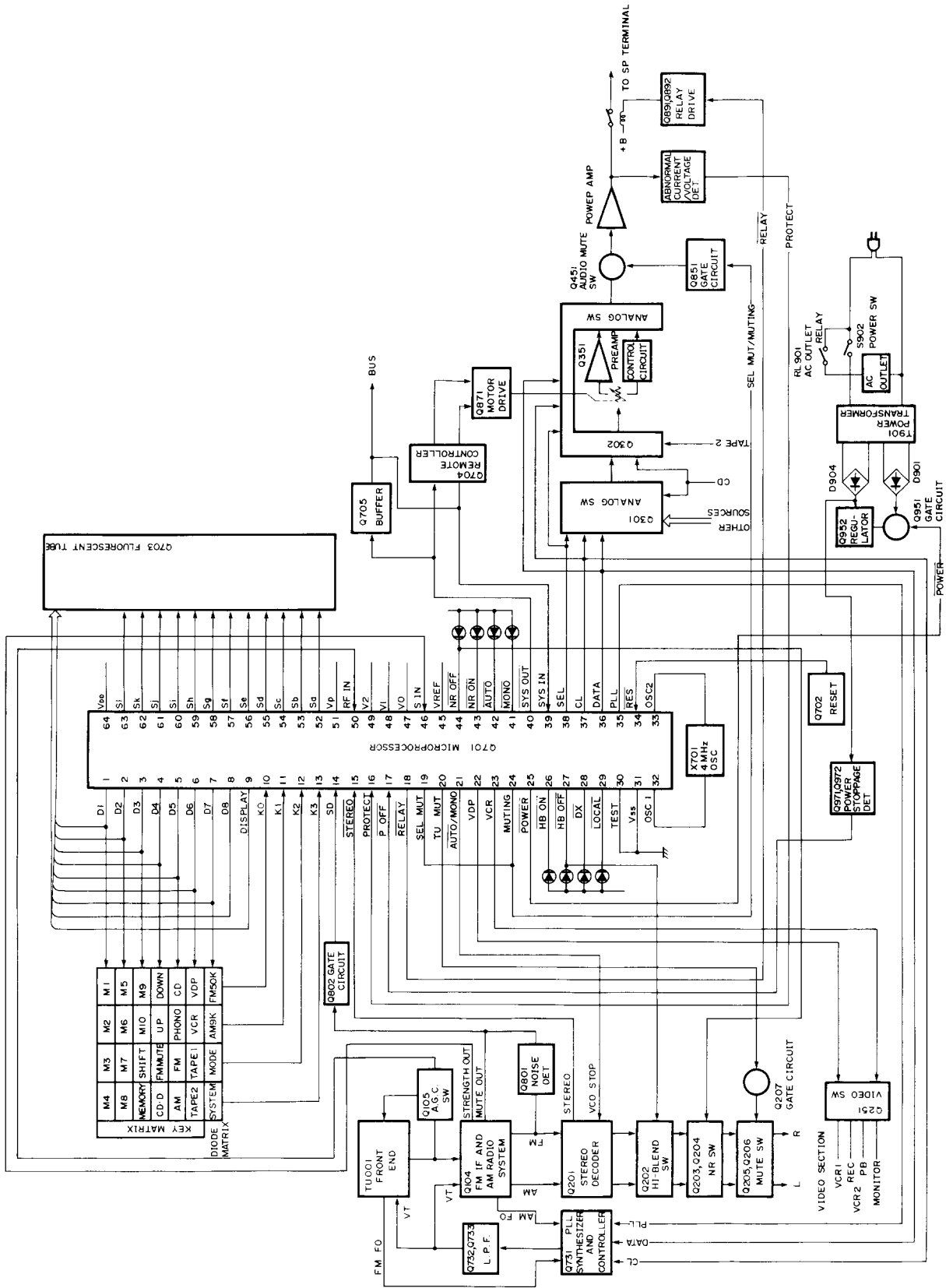

BLOCK DIAGRAM OF ICS

LC6568H-3643 (MICROPROCESSOR)

Terminal Descriptions

Pin No.	Terminal	Description
1	D1	These are the digit and key scan signal terminals. "H" when active.
2	D2	
3	D3	
4	D4	
5	D5	
6	D6	
7	D7	
8	D8	
9	DISPLAY	Display output terminal."H" when active.
10	K0	These are the input terminal for key return signal source and diode matrix."H" when active.
11	K1	
12	K2	
13	K3	
14	SD	Auto stop signal input terminal.Auto tuning stops when this terminal becomes the high level.
15	STEREO	This is the input terminal for detection of the stereo broadcast."L" when active.
16	PROTECT	This is the detection terminal for protection circuit.The speaker relay turns off when this terminal becomes the high level.
17	POWER OFF	This is the input terminal for detection of the stoppage of electric current."L" when the stoppage of electric current.
18	RELAY	This is the output terminal for control of the speaker relay."L" when active.
19	SEL MUTE	This is the muting output terminal when the selector key is operated."H" when active.
20	TU MUTE	This is the output terminal for muting control of tuner section."L" when active.
21	AUTO/MONO	This is the AUTO/MONO switching output terminal. "L" when AUTO.
22	VDP	These are the output terminal for control of video signal.
23	VCR	
24	MUTING	This is the output terminal for muting control. "H" when active.
25	POWER	This is the output terminal for power source.It is "H" for power on.
26	HB ON	This is the output terminal for indication of HI-BLEND ON. "L" when active.
27	HB OFF	This is the output terminal for indication of HI-BLEND OFF. "L" when active.
28	DX	This is the output terminal for indication of DX. "L" when active.
29	LOCAL	This is the output terminal for indication of LOCAL. "L" when active.
30	TEST	Test terminal.Connect to the ground.
31	Vss	Ground terminal.
32	OSC1	Connect to the 4.00MHz ceramic oscillator.
33	OSC2	
34	RES	This is the input terminal for reset. "L" when active
35	PLL	Connect to the terminal CE of PLL IC(LM7001).
36	DATA	This is the serial data output terminal.Connect to the terminal DATA of PLL IC and terminal DI of analog switches. (LC7821/LC7823)
37	CLOCK	This is the serial clock output terminal.Connect to the terminal CI of PLL IC and terminal CL of analog switches.
38	SEL	Connect to terminal SEL of analog switch(LC7821).
39	SYSTEM IN	This is the input terminal for system code. "H" when active.
40	SYSTEM OUT	This is the input terminal for system code. "L" when active.
41	MONO	This is the output terminal for indication of MONO. "L" when active.
42	AUTO	This is the output terminal for indication of AUTO. "L" when active.
43	NR ON	This is the output terminal for indication of NR ON. "L" when active.
44	NR OFF	This is the output terminal for indication of NR OFF. "L" when active.
45	VREF	This is the input terminal for comparator reference voltage.
46	S IN	This is the signal strength input terminal.
47	V0	This is the output terminal for comparator reference voltage.
48	V1	This is the output terminal for comparator reference voltage.
49	V2	This is the output terminal for comparator reference voltage.
50	RF IN	This is the input terminal for control of AGC. "H" when active.
51	VP	Pull-down resistor connection terminal of FIP controller/driver.

Pin No.	Terminal	Description
52	Sa	These are the output terminal for segment signal. "H" when active.
53	Sb	
54	Sc	
55	Sd	
56	Se	
57	Sf	
58	Sg	
59	Sh	
60	Si	
61	Sj	
62	Sk	This is the device power source terminal. At the time of operation, the supply is 5V. The internal data memory (RAM) is maintained by means of the super capacitor.
63	Sl	
64	VDD	

FM50K (FM band setting)

FM50K	Region	Frequency range	Channel space	Reference frequency	IF frequency
1	Europor	87.50 ~ 108.00MHz	50kHz	25kHz	10.7MHz
0	U.S.A.	87.9 ~ 107.9MHz	200kHz	25kHz	10.7MHz

AM9

AM9K	Region	Frequency range	Channel space	Reference frequency	IF frequency
1	Europor	522 ~ 1611 kHz	9kHz	9kHz	450kHz
0	U.S.A.	530 ~ 1620 kHz	10kHz	10kHz	450kHz

Connection of fluorescent tube and microprocessor

ANODE CONNECTION

	8 G (D 8)	7 G (D 7)	6 G (D 6)	5 G (D 5)	4 G (D 4)	3 G (D 3)	2 G (D 2)	1 G (D 1)
a	SLEEP		a	a	a	a	a	a
b	CD DIRECT		b	b	b	b	b	b
c	MEMORY		c	c	c	c	c	c
d	11-20		d	d	d	d	d	d
e	1-10	FM FM MUTE	e	e	e	e	e	e
f	AUDIO MUTE	STEREO	f	f	f	f	f	f
g	-	AM	g	g	g	g	g	g
h	T-2 MONITOR	OFF	-	-	-	h	-	h
i	-	ON	i	-	i	-	-	i
j	-	MIN	j	-	-	-	-	j
k	-	kHz	-	-	k	k	-	k
l	-	MHZ	-	-	DP	-	-	CH
m	PRESET STATION	-	-	-	-	-	-	-
n	SIGNAL FREQUENCY / INPUT SELECTOR	-	-	-	-	-	-	-
o	-	SIGNAL STRENGTH	-	-	-	-	-	-
p	-		-	-	-	-	-	-

μPA81C (BUFFER)

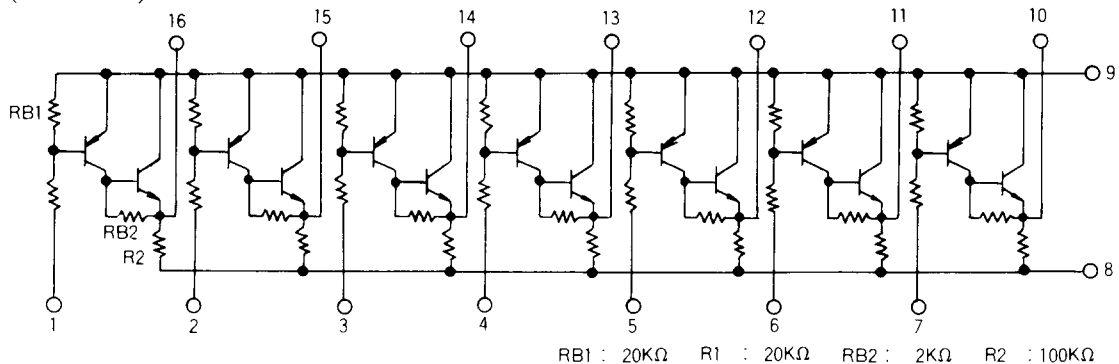

7-BT-95GK (FLUORESCENT TUBE)

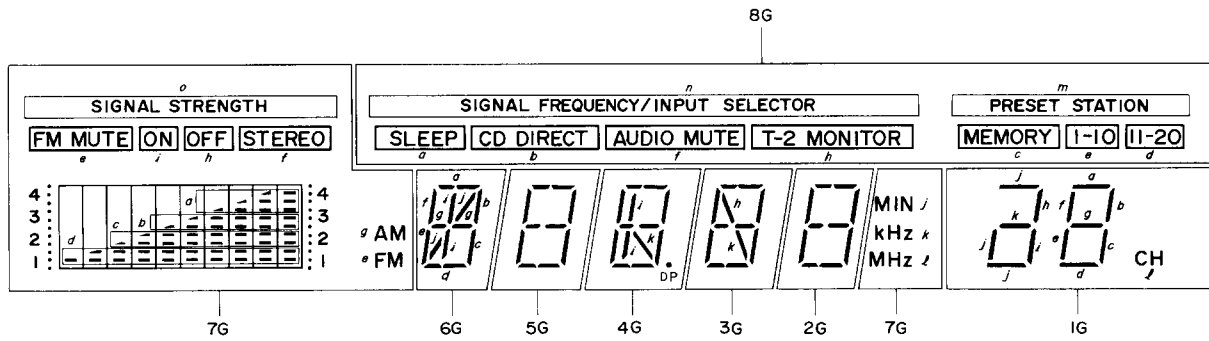

LC7823 (ANALOG SWITCH)

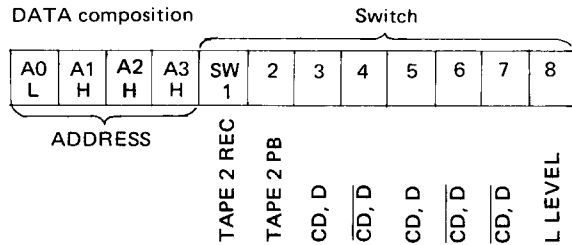
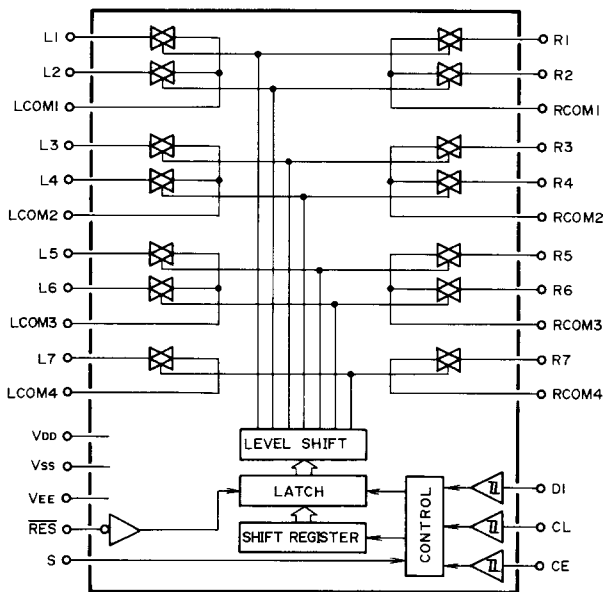

The source becomes ON when the bit of switch becomes high.

Pin No.	Terminal	Description	Pin No.	Terminal	Description
1 (L1)	TAPE 2 REC	Input/output terminals of audio signal of left channel. Control to the inside analog switch at the serial data.	16	Vss	Ground terminal.
2 (L2)	TAPE 2 PB		17	S	Selector terminal.
3	L COM 1		18	RES	Reset terminal. When power is turned ON, the condition of the analog switch is not determined, but when this terminal is "L", all analog switches are OFF.
4 (L3)	CD·D		19	VDD	Power supply terminal. (+15V)
5 (L4)	CD·D		20	R COM 4	Input/output terminals of audio signal of right channel. Control to the inside analog switch at the serial data.
6	L COM 2		21 (R7)	CD·D	
7 (L5)	CD·D		22	R COM 3	
8 (L6)	CD·D		23 (R6)	CD·D	
9	L COM 3		24 (R5)	CD·D	
10 (L7)	CD·D		25	R COM 2	
11	L COM 4		26 (R4)	CD·D	
12	VEE	27 (R3)	CD·D		
13	CE	28	R COM 1		
14	D1	29 (R2)	TAPE 2 PB		
15	CL	30 (R1)	TAPE 2 REC		

ADJUSTMENT PROCEDURES

Preparation

• Input

FM mono: 1kHz, 75kHz devi., 60dB/ μ V

FM stereo: 1kHz, L+R 67.5kHz devi.: Pilot signal 19kHz
7.5kHz devi.

AM: 400Hz, 30% mod.,

• Output

Connect the non-inductive type resistor of 8 ohms to the speaker terminal A of left and right channels unless otherwise noted.

• Standard knob position

TAPE MONITOR	SOURCE
VOLUME	Maximum
BASS/TREBLE/BALANCE	Center
VCR 2 MODE	STEREO
SPEAKER	A
SIMULATED STEREO	OFF
DYNAMIC BASS EXPANDER	OFF
STEREO IMAGE EXPANDER	OFF
SELECTIVE TONE CONTROL	OFF

Amplifier section

1. Idling current adjustment

Connect the DC voltmeter to the terminals IID and VCT on the power amplifier pc board.

Adjust the semi-fixed resistors R533 and R534 so that the indication of voltmeter is 7.5 ± 1.5 mV.

Notes: VOLUME Maximum, Open load,
Adjust after switching on for 5 minutes.

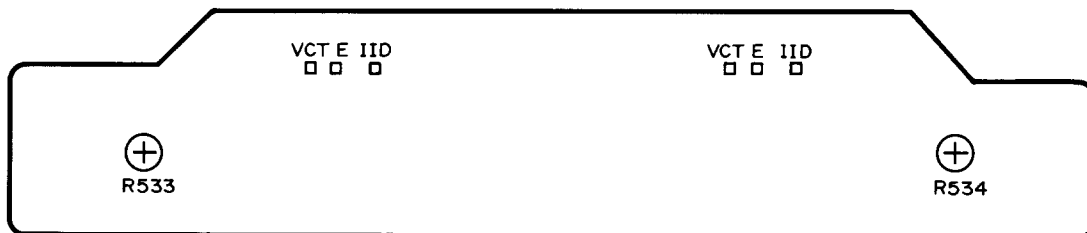

Power amplifier pc board

I section

Item	Step	Connection of instrument	FM SG output	Stereo modulator output	Turning dial setting	Output indicator	Adjustment	Adjust for	Remarks
FM IF	1		99.1MHz	-	99.1MHz	DC voltmeter	L101	0V ± 20mV	Mode switch: MONO Repeat the steps 1 and 3 until no further adjustment is necessary
	2	Fig. 1	1kHz, 75kHz devl. 65dBf (60dB)			AC voltmeter	IF on the front end	Maximum	
	3					Distortion analyzer	L102	Minimum	
Stereo indicator level	1		99.1MHz 17.2dBf (12dB) Ext. modulation	L + R : 1kHz 67.5kHz devl.	99.1MHz	Stereo indicator	R101	Light on	Mode switch: STEREO
	2	Fig. 3	99.1MHz 16.2dBf (11dB) Ext. modulation	Pilot signal 19kHz 7.5kHz devl.				Light off	
VCO			99.1MHz 1kHz, 75kHz devl. 65dBf (60dB)	-	99.1MHz	Frequency counter	R201	19kHz ± 10Hz	
Stereo Distortion	1		99.1MHz 65dBf (60dB) Ext. modulation	L or Rch. 1kHz	99.1MHz	Distortion analyzer	IF on the front end	Minimum	Don't turn more than ± 180°
	2	Fig. 3	99.1MHz 65dBf (60dB) Ext. modulation	Lch. 1kHz Rch. 1kHz		Rch. AC voltmeter Lch. AC voltmeter	R202	Minimum	
-blend level			99.1MHz 35.2dBf (30dB) 1kHz, 75kHz devl.	-	99.1MHz	Hi-blend indicator	R102	Light off	

A section

Step	AM SG output	Tuned frequency	Output indicator	Adjustment point	Adjust for
1		530kHz [522kHz] (531kHz)	Digital DC voltmeter	OSC on RF block	1.3V ± 0.1V
2	600kHz(603kHz) 400Hz 30% mod. 60dB/m	600kHz (603kHz)	AC voltmeter	RF on RF block	Maximum
3	1000kHz (999kHz) 400Hz 30% mod. 60dB/m	1000kHz (999kHz)	AC voltmeter	L152	Maximum
4	Same as above	1000kHz (999kHz)	First signal indicator	R151	Light on

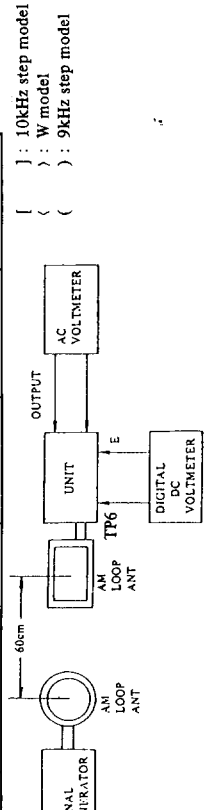

Reference specifications
 FM Tuned voltage
 87.9MHz 2.0 ± 0.5V
 107.9MHz 7.7 ± 0.5V (120V model)
 87.5MHz 2.0 ± 0.5V
 108.0MHz 7.7 ± 0.5V (Other models)

Auto stop level
 AM: Less than 66dB/m
 FM: Less than 17dBμ

AM Tuned voltage
 530kHz 1.3 ± 0.5V
 1620kHz 8.0 ± 0.5V (120V model)
 522kHz 1.3 ± 0.5V
 1611kHz 8.0 ± 0.5V (Other models)

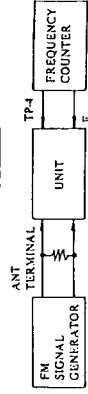
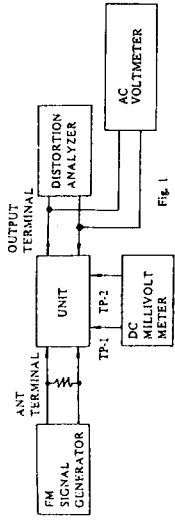

Use the high impedance probe. (10:1)

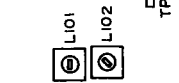
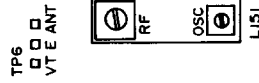
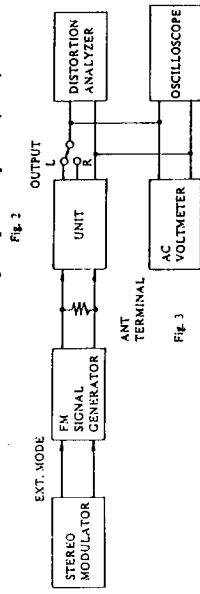

FM/AM tuner and selector switch pc board

TP4

DISPLAY PC BOARD PRINTED CIRCUIT BOARD-PARTS LIST

DISPLAY PC BOARD(NADIS-3281-1/1A/1B)

CIRCUIT NO.	PART NO.	DESCRIPTION			
		ICs			
U701	24130001	GP1U501S	X702	3010119	CSB-1000D,Ceramic
Q701	22240153	LC6568H-3643		Capacitors	
Q704	22240150	LC6527C-3608	C702	3020027 or	0.047F,5.5V or
		Transistors		3000051	0.047F,5.5V,Super
Q702	2211255 or	2SC1815(GR) or	C704	354780109	1 μ F,50V,Elect.
	2210746	2SC945A(P)	C707,C715	354782299	0.22 μ F,50V,Elect.
Q705	2211455 or	2SA1015(GR) or	C708	354741009	10 μ F,16V,Elect.
	2210803	2SA733(P)		Resistors	
		Fluorescent tube	R710	49163473404	47kohm \times 4, 1/10W,Network
Q703	212054	7-BT-95GK	R734,R735	49163104404	100kohm \times 4, 1/10W,Network
		Lamp		Switches	
Q706	210064A	6.3V,0.25A	S701-S724	25035548	NPS-111-S510
		Diodes	S725	25065286	NSS-22112,Band <W>
D702-D715	223163	1SS133		Relay	
D716,D717	223163	1SS133 <G/W>	RL701	25065298	NRL-1P1A-DC12-40
D718,D720	224650822,	05AZ8.2Y,		Holder	
	224150822 or	HZ8.2EB2 or		27190643A	L.E.D
	224450822	MTZ8.2B			
D719	223163	1SS133			
D720	224150562 or	05AZ5.6Y or			
	224650562	HZ5.6EB2			
D733-D735	223163	1SS133			
		L.E.Ds			
D721,D723	225137CG,	SEL2413ECG,			
D725,D727	225137DG or	SEL2413EDG or			
D729-D731	224137DY	SEL2413EDY			
D722,D724	225142	SEL2913K			
D726,D728	225142	SEL2913K			
D732	225141	SEL2213C			
		Osc. elements			
X701	3010099	CSA4.00MG,Ceramic			

SPEAKER SWITCH PC BOARD(NASW-3278-1/1A)

CIRCUIT NO.	PART NO.	DESCRIPTION
R549,R550	442520474	4.7ohm,1/2W,Metal oxide film resistors
R551,R552	441623914	390ohm,1W,Metal oxide film resistors
S502,S503	25035517	NPS-222-L479,Push switch
P503	25045187	HLJ-0541-01-010,Stereo headphone terminal <D/W>
	25045139	HLJ-0540-01-010,Stereo headphone terminal <G>

PREAMPLIFIER PC BOARD(NAAF-3283-1/1A)

CIRCUIT NO.	PART NO.	DESCRIPTION
Q352	222579 or 222570	NJM4560D or NJM4560DX
Q353	222465	NJM4558D
Transistors		
Q851	2212600	DTA124ES
Q853	221281	DTC114YS
Diodes		
D351	224650623 or 224150623	HZ6.2EB3 or 05AZ6.2Z
D352,D353	223163	1SS133
Capacitors		
C359,C360	354780229	2.2 μ F,50V,Elect.
C363,C364	354741009	10 μ F,16V,Elect.
C367,C368	352983396	0.33 μ F,50V,Non-polar elect.
C373,C374	354780229	2.2 μ F,50V,Elect.
C375-C378	354781099	0.1 μ F,50V,Elect.
C389	354780229	2.2 μ F,50V,Elect.
C390,C392	354781099	0.1 μ F,50V,Elect.
C393,C851	354780339	3.3 μ F,50V,Elect.
Resistors		
R371,R372	5104216	N14RLC50KC22Z, Variable,Bass
R379,R380	5104216	N14RLC50KC22Z, Variable,Treble
R451	5104225	N11RGLC250KW22Z, Variable,Bal- ance
Switch		
S354	25035590	NPS-122-L552

SPEAKER TERMINAL PC BOARD(NAETC-3279-1/1A)

CIRCUIT NO.	PART NO.	DESCRIPTION
P501,P502	25060110	NTM-4PDMN44,Speaker termi- nals

SPEAKER SWITCH PC BOARD

NOTE: <D>: Only 120V model
<G>: Only 220V/240V models
<W>: Only Worldwide model

SCHEMATIC DIAGRAM

- TUNER SECTION -
- 120V MODEL -

NAAS-3276-1-2,21

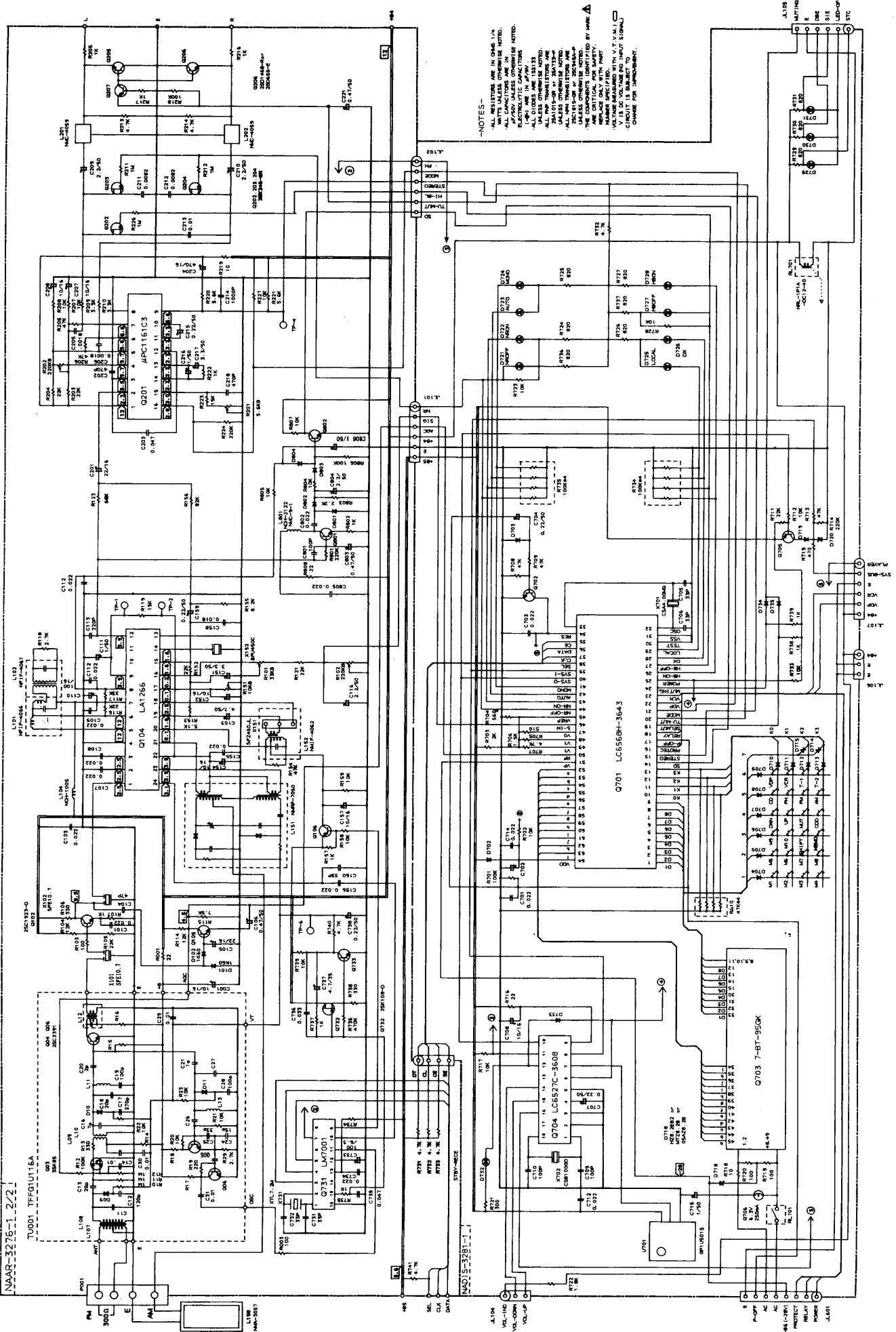

SCHEMATIC DIAGRAM

- AMPLIFIER SECTION -

- 120V MODEL -

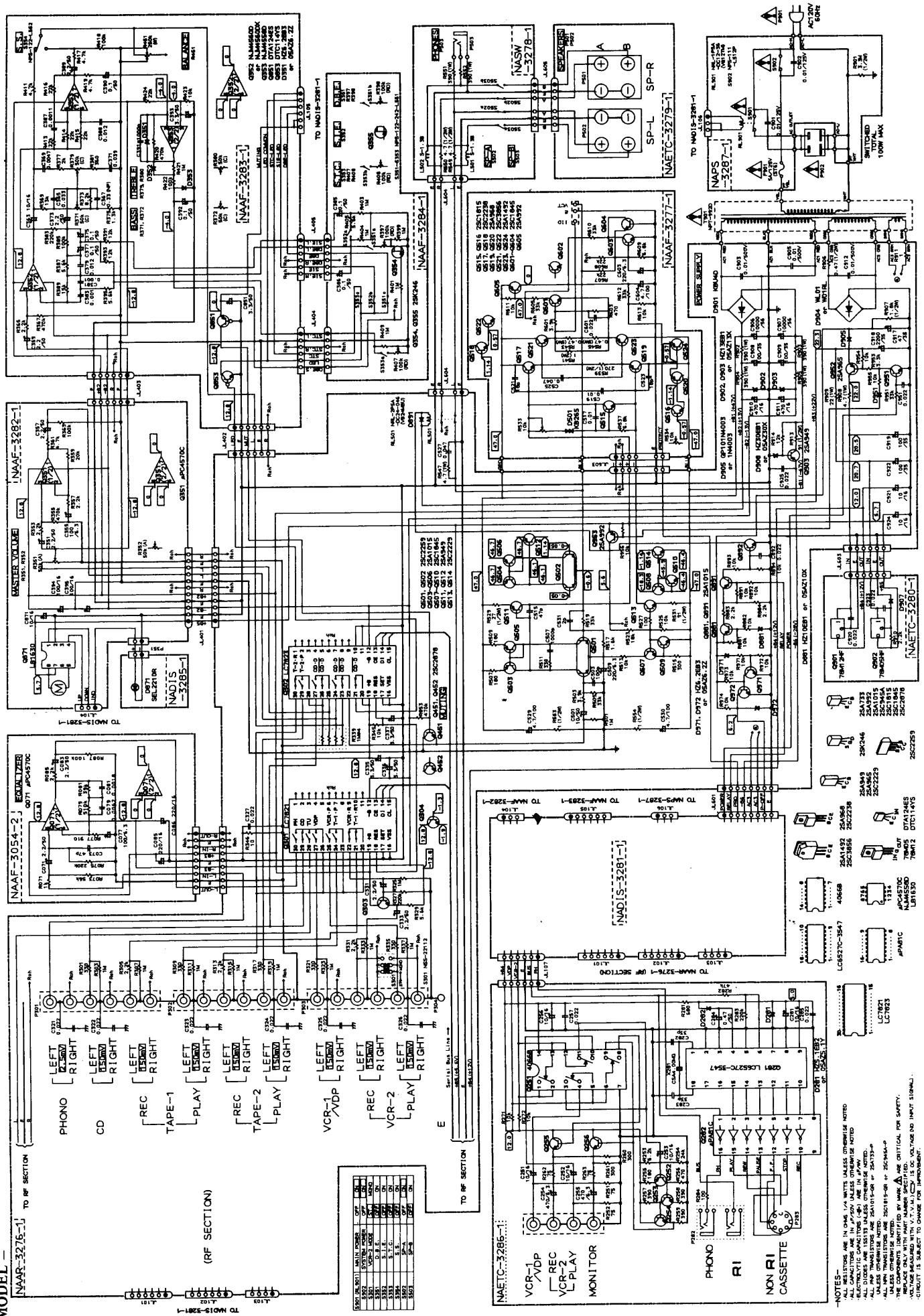

RES. VALUE	RES. VALUE	RES. VALUE	RES. VALUE
RES1	RES2	RES3	RES4
RES5	RES6	RES7	RES8
RES9	RES10	RES11	RES12
RES13	RES14	RES15	RES16
RES17	RES18	RES19	RES20
RES21	RES22	RES23	RES24
RES25	RES26	RES27	RES28
RES29	RES30	RES31	RES32
RES33	RES34	RES35	RES36
RES37	RES38	RES39	RES40
RES41	RES42	RES43	RES44
RES45	RES46	RES47	RES48
RES49	RES50	RES51	RES52
RES53	RES54	RES55	RES56
RES57	RES58	RES59	RES60
RES61	RES62	RES63	RES64
RES65	RES66	RES67	RES68
RES69	RES70	RES71	RES72
RES73	RES74	RES75	RES76
RES77	RES78	RES79	RES80
RES81	RES82	RES83	RES84
RES85	RES86	RES87	RES88
RES89	RES90	RES91	RES92
RES93	RES94	RES95	RES96
RES97	RES98	RES99	RES100

-NOTES-
 ALL RESISTORS ARE IN OHMS UNLESS OTHERWISE NOTED.
 ALL CAPACITORS ARE IN MICROFARADS UNLESS OTHERWISE NOTED.
 ALL DIODES ARE 1N4148 UNLESS OTHERWISE NOTED.
 ALL IC'S ARE IDENTIFIED BY PART NO. IN CIRCLE.
 THE COMPONENTS IDENTIFIED BY MARK 'A' ARE CRITICAL FOR SAFETY.
 REPLACE THESE COMPONENTS WITH THE SAME TYPE AND VOLTAGE RATING.
 CIRCUIT IS SUBJECT TO CHANGE FOR IMPROVEMENT.

PRINTED CIRCUIT BOARD-PARTS LIST

FM/AM TUNER AND SELECTOR CIRCUIT PC BOARD(NAAR
-3276-1/1A/1B)

CIRCUIT NO.	PART NO.	DESCRIPTION	CIRCUIT NO.	PART NO.	DESCRIPTION
TU001	240070	TFFGIU116A <D>	L103	233383	NMC-6070 <G/W>
	240081	TFFG3E <G/W>	L104	233105	NCH-1005
	ICs		L201,L202	233355A	NMC-4059
Q104	22240039	LA1266	L801	231081 or 233031	NCH-2129 or NMC-9-1
Q201	222678	μ PC1161C3		RF block	
Q301	22240079	LC7821	L151	232148	NMRF-7050
Q302	22240158	LC7823		Ceramic filters	
Q731	22240090	LM7001	X101,X102	3010071	SFE10.7MA5 (RED) <D>
	Transistors		X101-X103	3010137	SFE10.7MMK <G/W>
Q101	2212195	2SK241(GR) <G/W>	X151	3010123	SFZ450JL
Q102	2211723	2SC1923(O)	X152	3010076	BFU450C
Q103	2211723	2SC1923(O) <G/W>		X'tal	
Q105	2211255 or 2210746	2SC1815(GR) or 2SC945A(P)	X731	3010073	XTL-7.2M
Q106,Q207	2211455	2SA1015(GR)		Capacitors	
Q202-Q204	2211945	2SK246(GR)	C001	354741009	10 μ F,16V,Elect.
Q205,Q206	2211705 or 2212794	2SD655(E) or 2SD1468(R)	C105	354742209	22 μ F,16V,Elect.
Q303,Q304	2211255 or 2210746	2SC1815(GR) or 2SC945A(P)	C106	354784799	0.47 μ F,50V,Elect.
Q451,Q452	2212285 or 2212286	2SC2878(A) or 2SC2878(B)	C110	354741019	100 μ F,16V,Elect.
Q501,Q502	2211371 or 2211372	2SC2259(O-001) or 2SC2259(O-002)	C111	354780109	1 μ F,50V,Elect.
Q503-Q506	2211455	2SA1015(GR)	C116	354780229	2.2 μ F,50V,Elect.
Q507-Q510	2211732 or 2211733	2SC1845(F) or 2SC1845(E)	C151	354780339	3.3 μ F,50V,Elect.
Q511,Q512	2211353 or 2211354	2SA949(O) or 2SA949(Y)	C152	354741009	10 μ F,16V,Elect.
Q513,Q514	2211633 or 2211634	2SC2229(O) or 2SC2229(Y)	C153	354780479	4.7 μ F,50V,Elect.
Q732	2212294	2SK108(D)	C154,C157	354741009	10 μ F,16V,Elect.
Q733,Q801	2211255 or	2SC1815(GR) or	C159	354782299	0.22 μ F,50V,Elect.
Q802,Q892	2210746	2SC945A(P)	C201	354742209	22 μ F,16V,Elect.
Q881,Q891	2211455	2SA1015(GR)	C204	354744719	470 μ F,16V,Elect.
Q903	2211353 or 2211354	2SA949(O) or 2SA949(Y)	C207,C208	354741009	10 μ F,16V,Elect.
Q951,Q971	2211255 or	2SC1815(GR) or	C209,C210	354780229	2.2 μ F,50V,Elect.
Q972	2210746	2SC945A(P)	C215	354782299	0.22 μ F,50V,Elect.
Q952	2211643 or 2211644	2SA965(O) or 2SA965(Y)	C216	354780109	1 μ F,50V,Elect.
Q953	2211792 or 2211793	2SA992(F) or 2SA992(E)	C217	354780339	3.3 μ F,50V,Elect.
	Diodes		C218	370134714	470pF \pm 5%,100V,APS
D101,D102	223132	1K60	C221	354784799	0.47 μ F,50V,Elect.
D801-D804	223163	1SS133	C331-C334	354780229	2.2 μ F,50V,Elect.
D881	224651001 or 224151001	HZ10EB1 or 05AZ10X	C335-C337	354780339	3.3 μ F,50V,Elect.
D891	223163	1SS133	C501,C502	354781009	10 μ F,50V,Elect.
D901	22380024	KBU4D	C509,C510	354722219	220 μ F, 6.3V,Elect.
D902,D903	224151301 or 224651301	05ZA13X or HZ13EB1	C529,C530	354790479	4.7 μ F, 100V,Elect.
D904	223862 or 223890	WL01 or W01RL	C733	354721019	100 μ F, 6.3V,Elect.
D905	223880 or 223896	GP101N4003 or 1N4003F	C737	354780479	4.7 μ F,50V,Elect.
D908	224153001 or 224653001	05AZ30X or HZ30EB1	C738	354782299	0.22 μ F,50V,Elect.
D951	223163	1SS133	C803	354784799	0.47 μ F,50V,Elect.
D971,D972	224650623 or 224150623	HZ6.2EB3 or 05AZ6.2Z	C804	354780229	2.2 μ F,50V,Elect.
	Transformers		C806	354780109	1 μ F,50V,Elect.
L101	233389	NFIF-4066	C903,C905	335251039A	0.01 μ F,500V,Ceramic
L102	233390	NFIF-4067	C906,C907	3504224	10000 μ F,56V,Elect.
L152	232139	NMIF-4062	C908,C909	354761019	100 μ F,35V,Elect.
			C910,C911	354744719	470 μ F,16V,Elect.
			C912	335251039A	0.01 μ F,500V,Ceramic
			C917	354764709	47 μ F,35V,Elect.
			C918	354762229	2200 μ F,35V,Elect.
			C919	354761019	100 μ F,35V,Elect.
			C921,C924	354741009	10 μ F,16V,Elect.
			C922	354761019	100 μ F,35V,Elect.
				Resistors	
			R101	5210067	N06HR33KBD,Semi-fixed
			R102	5210072	N06HR220KBD,Semi-fixed
			R151	5210064	N06HR10KBD,Semi-fixed
			R201	5210062	N06HR4.7KBD,Semi-fixed
			R202	5210072	N06HR220KBD,Semi-fixed
			R339,R340	49163105404	1Mohm \times 4,1/10W,Network
			R529,R530	442522704	27ohm,1/2W,Metal oxide film
			R531,R532	442529104	91ohm,1/2W,Metal oxide film

PRINTED CIRCUIT BOARD VIEW FROM BOTTOM SIDE

POWER AMPLIFIER PC BOARD

CIRCUIT NO.	PART NO.	DESCRIPTION
R547,R548	441620474	4.7ohm,1W,Metal oxide film
R553,R554	442520104	1ohm,1/2W,Metal oxide film
R902-R905	441623914	390ohm,1W,Metal oxide film <D>
R902,R903	441725114	510ohm,2W,Metal oxide film <G/W>
R904,R905	441623314	330ohm,1W,Metal oxide film <G/W>
R906	442524794	0.47ohm, 1/2W,Metal oxide film <D/W>
R907	442521824	1.8kohm,1/2W,Metal oxide film
R908	441620474	4.7ohm,1W,Metal oxide film
R909	441622204	22ohm,1W,Metal oxide film
R913	442529104	91ohm, 1/2W,Metal oxide film
Relay		
RL501	25065339	NRL-2P5A-DC24-046
Terminals		
P001	25060085	NTM-4PDMN29,Antenna <D>
	25060087	NTM-2PDMN31,Antenna <G/W>
P301-P303	25045213	NPJ-6PDBL-92
Switch		
S301	25065286	NPS-22112,VCR mode
Sockets		
P101,P102	25050270	NSCT-6P98
P402,P602	25050270	NSCT-6P98
P103	25050268	NSCT-4P96
P401	25050275	NSCT-11P103
P601	25050272	NSCT-8P100
Fuse		
F906	252070	1A-SE-EAK,Secondary <G>
Fuseholders		
F906a	25050065	YSH403T <G>
Radiator		
	27160166	

NOTE: <D>: Only 120V model
 <G>: Only 220V/240V models
 <W>: Only Worldwide model

POWER AMPLIFIER PC BOARD(NAAF-3277-1)

CIRCUIT NO.	PART NO.	DESCRIPTION
Transistors		
Q515,Q516	2211255	2SC1815(GR)
Q517,Q518	2200863 or 2200864	2SC2238(O) or 2SC2238(Y)
Q519,Q520	2200873 or 2200874	2SA968(O) or 2SA968(Y)
Q521,Q522 ☆	2201653, 2201654 or 2201655	2SC3856(O), 2SC3856(Y) or 2SC3856(P)
Q523,Q524 ☆	2201663, 2201664 or 2201665	2SA1492(O), 2SA1492(Y) or 2SA1492(P)

CAUTION: Replacement for transistor of mark ☆,if necessary, must be made from the same beta group (H_{FE}) as the original type.

Ex. 2SC3856(O) 2SA1492(O)

Same beta group

Q601-Q604	2211732 or 2211733	2SC1845(F) or 2SC1845(E)
Q605	2211792 or 2211793	2SA992(F) or 2SA992(E)
Diodes		
D501,D502	4000120	KB265
Capacitors		
C603	354722219	220 μF, 6.3V,Elect.
C604	354790479	4.7 μF, 100V,Elect.

Resistors		
R533,R534	5210064	N06HR10KBD,Semi-fixed
R539,R540	442522714	270ohm,1/2W,Metal oxide film
R541,R542	441720104	1ohm,2W,Metal oxide film
R543-R546	4000080 or 4500022	0.47ohm,5W,Metal plate

Terminals
 25060118 NTM-1S52,For leg of power transistor

PRINTED CIRCUIT BOARD-PARTS LIST

VIDEO TERMINAL PC BOARD(NAETC-3286-1/1A)

CIRCUIT NO.	PART NO.	DESCRIPTION
Q251	222840661	4066B
Q281	22240145	LC6527C-3547
Q282	222807	μ PA81C
Transistors		
Q252	2211455 or 2210803	2SA1015(GR) or 2SA733(P)
Q253-Q256	2211255 or 2210746	2SC1815(GR) or 2SC945A(P)
Diodes		
D281	224650512	HZ5.1EB2 or
	224150512	05AZ5.1Y
D282	223163	1SS133
Osc. element		
X281	3010099	CSA4.00MG,Ceramic
Capacitors		
C251-C253	354741009	10 μ F,16V,Elect.
C254,C255	354724719	470 μ F,6.3V,Elect.
C256,C281	354741009	10 μ F,16V,Elect.
C284	354784799	0.47 μ F,50V,Elect.
Terminals		
P251	25045216	NPJ-4PDBL94
P282	25045172	HSJ1003-01-020
Socket		
P283	25050294	NSCT-8P121

VOLUME PC BOARD(NAAF-3282-1/1A)

CIRCUIT NO.	PART NO.	DESCRIPTION
Q351	22240050	μ PC4570C,IC
Q871	222963	LB1630,IC
C351,C352	354780229	2.2 μ F,50V,Elect. capacitors
C355,C356	354721019	100 μ F,6.3V, Elect. capacitors
C357,C358	354780229	2.2 μ F,50V,Elect. capacitors
C394,C395	354741019	100 μ F,16V,Elect. capacitors
C871	354741009	10 μ F,16V,Elect. capacitor
R351,R352	5104234	N16RGM50KA30F,Variable resistor,Volume
P351	2000635A	NSAS-4P591,Socket
	25050270	NSCT-6P98,Socket

VOLUME INDICATOR PC BOARD(NADIS-3285-1)

CIRCUIT NO.	PART NO.	DESCRIPTION
D871	225241 or 225242	SEL2210R-C or SEL2210R-D,LED
	27190545	Holder,LED

CONST. VOLTAGE CIRCUIT PC BOARD(NAETC-3280-1)

CIRCUIT NO.	PART NO.	DESCRIPTION
Q901	222780125	NEC 78M12HF,IC
Q902	222780055	NEC 78M05HF,IC
D907	223163	1SS133,Diode

SWITCH PC BOARD(NAAF-3284-1)

CIRCUIT NO.	PART NO.	DESCRIPTION
Transistors		
Q354,Q355	2211945	2SK246(GR)
Capacitors		
C385,C386	354781099	0.1 μ F,50V,Elect.
Resistors		
R397,R398	6182003	N25LGL100KRD10Z,Variable,D.B.E
R407,R408	6182003	N25LGL100KRD10Z,Variable,S.T.C
Switches		
S351-S353	25035589	NPS-122-242-L551

EQUALIZER AMPLIFIER PC BOARD(NAAF-3054-2/3)

CIRCUIT NO.	PART NO.	DESCRIPTION
IC		
Q071	22240191 or 222570	NJM4565DD or NJM4560DX
Elect. capacitors		
C071,C072	354780229	2.2 μ F,50V
C077,C078	354721019	100 μ F,6.3V
C083,C084	354780229	2.2 μ F,50V
C085,C086	354742219	220 μ F,16V
Plug		
P071	25055334	NPLG-9P317

NOTE: <D>: Only 120V model
<G>: Only 220V/240V model
<W>: Only Worldwide model

POWER SUPPLY CIRCUIT PC BOARD(NAPS-3287-1/1A/1B/1C)

CIRCUIT NO.	PART NO.	DESCRIPTION
C901,C902	3500065A	Δ DE7150FZ103PAC400V/125V, Capacitor IS
R901	431523355	Δ 3.3Mohm,1/2W,Solid resistor <D>
S902	25035550	Δ NPS-111-L512P,Power
RL901	25065269	Δ NRL-1P5A-DC12-36,Relay <D>
	25065248	Δ NRL-1P15A-DC12-29,Relay <G/ W>
F901a	250113	Δ SN5051,Fuseholders <D/W>
F901	252050	Δ 5A(ST-6),Primary fuse <D/W>
F902a	25050065	Δ YSH-403T,Fuseholders <G/W/Q>
F902	252075	Δ 2.5A-SE-EAK,Primary fuse <G/ W/Q>
F903a	25050065	Δ YSH-403T,Fuseholders <G>
F903	252075	Δ 2.5A-SE-EAK,Fuse for AC outlet <G>
	29360626-1	Label, fuse <D>

NOTE: <D>: Only 120V model
<G>: Only 220V model
<W>: Only Worldwide model
<Q>: Only 240V model

NOTE: THE COMPONENTS IDENTIFIED BY MARK Δ ARE CRITICAL FOR RISK OF FIRE AND ELECTRIC SHOCK. REPLACE ONLY WITH PART NUMBER SPECIFIED.

DISASSEMBLING PROCEDURES

1. Top cover

Remove a screw (3TTS+8BQ(BC)) holding the top cover and the back panel.
Remove the four screws (3TTS+8B(BC)) holding the back panel and the chassis.

2. Front panel

Remove the top cover.
Remove the six screws (3TTP+8P(BC)) holding the front panel and the front basket.

3. Power amplifier pc board

Remove the top cover.
Remove the five screws A.
Cut the binder B.

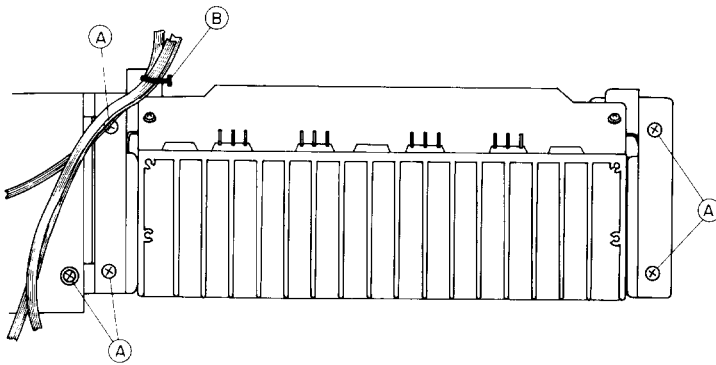

4. FM/AM tuner and selector switch pc board

Remove the top cover.
Remove the three screws C holding the pc board and chassis.
Remove the five screws D holding the back panel and chassis.
Remove the pc board from the two holders.

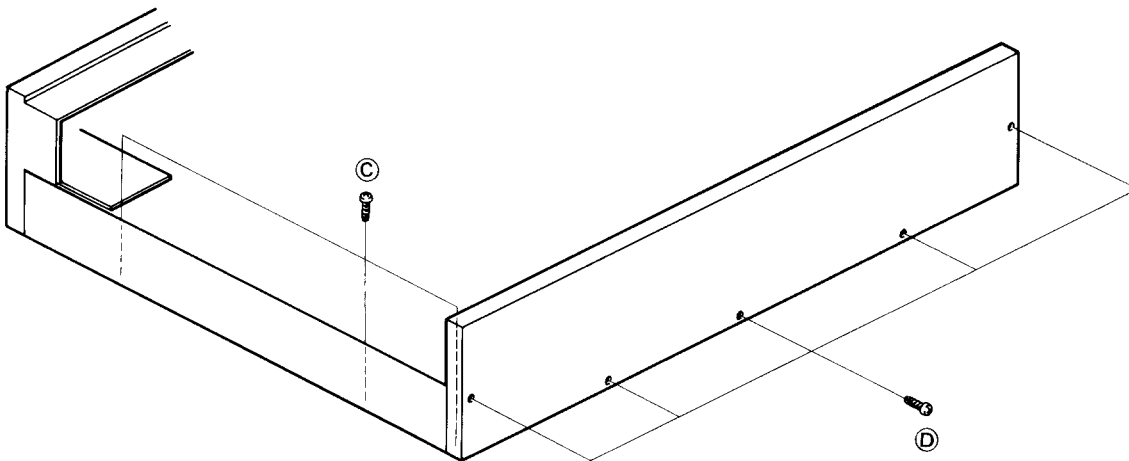

PACKING VIEW

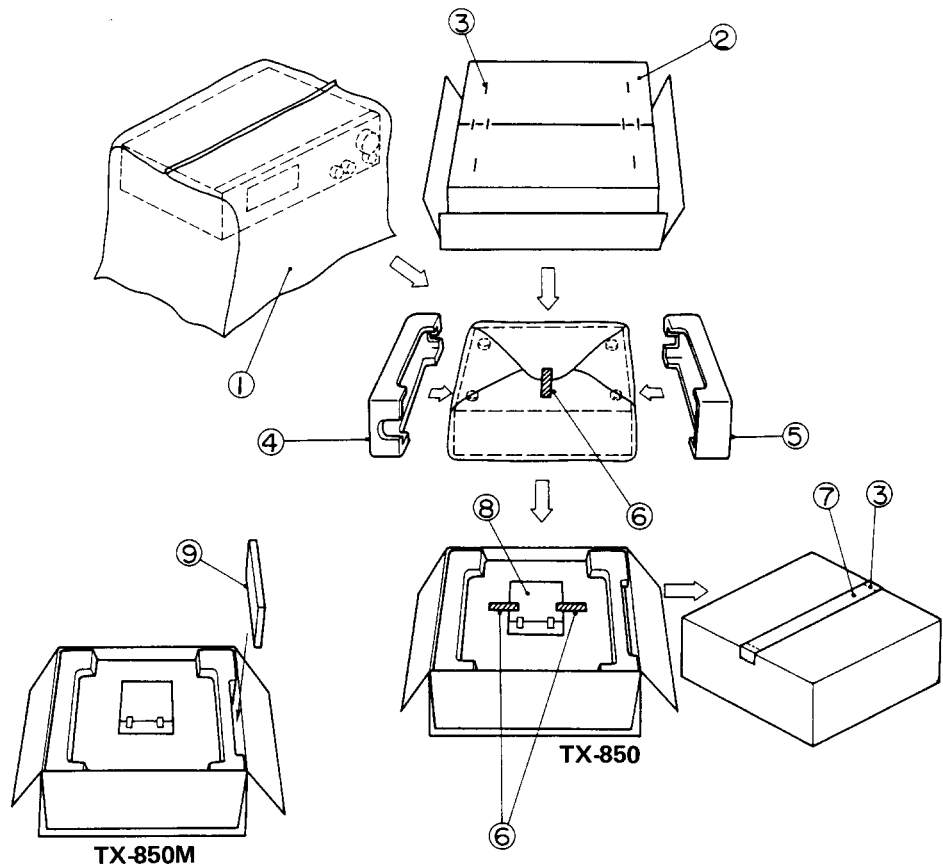

REF. NO.	PART NO.	DESCRIPTION		
1	29100034	850×650mm,Poly-vinyl bag		25060123 FM adaptor (240V model)
	29095012-1	800×500mm,Protection sheet		-Worldwide model-
2	29051687	Master carton box (TX-850)		29341254 Instruction manual
	29051688	Master carton box (TX-850M)		292092 FM antenna
	29051690	Master carton box (PX model)		232140 NMA-3057,AM loop antenna
3	282301	Sealing hook		2010169 Connection cord for RI
4	29091263	Pad R		3010054 UM-3,Two batteries
5	29091262	Pad L		24140025 RC-119S,Remote control transmitter
6	29110032	Adhesive tape		29100097 250×350mm,Poly-vinyl bag
7	260012	Damplon tape		25060123 FM adaptor
8	Accessary bag ass'y			25055018 CV-K-1,Conversion plug
	-120V model-			-PX model-
	29341252	Instruction manual		29341254 Instruction manual
	292064B	FM antenna		292064B FM antenna
	232140	NMA-3057,AM loop antenna		232140 NMA-3057,AM loop antenna
	2010169	Connection cord for RI		2010169 Connection cord for RI
	3010054	UM-3,Two batteries (TX-850)		3010054 UM-3, Four batteries
		UM-3,Four batteries (TX-850M)		24140024 RC-AV10M, Remote control transmitter
	24140021	RC-118S,Remote control transmitter (TX-850)		29100097 250×350mm,Poly-vinyl bag
	29380091	Caution sheet (U.S.A. model)		25060123 FM adaptor
	29100097	250×350mm,Poly-vinyl bag		25055251 CV-CP, Conversion plug
	29365019	Warranty card (U.S.A. model)		29365021 Warranty card
	29358002F	Service station list (U.S.A. model)		29358002F Service station list
	-220V/240V models-		9	29341248 Instruction manual for remote control
	29341254	Instruction manual		24140024 RC-AV10,Remote control transmitter (TX-850M)
	292092	FM antenna		29341248 Instruction manual for remote control
	232140	NMA-3057,AM loop antenna		(Refer the service manual of RC-AV10M)
	2010169	Connection cord for RI		
	3010054	UM-3,Two batteries		
	24140025	RC-119S,Remote control transmitter		
	29100097	250×350mm,Poly-vinyl bag		

ONKYO CORPORATION

International Division: No. 24 Mori Bldg., 23-5, Nishi-Shimbashi 3-chome, Minato-ku, TOKYO 105. JAPAN Telex: 242-3551 ONKYO J. Tel. 03-432-6981

ONKYO U.S.A CORPORATION

200 Williams Drive, Ramsey, N.J. 07446 Telex: 25-710-988-1033 Tel. 201-825-7950