

ONKYO® SERVICE MANUAL

QUARTZ LOCKED STEREO RECEIVER MODEL TX-8500

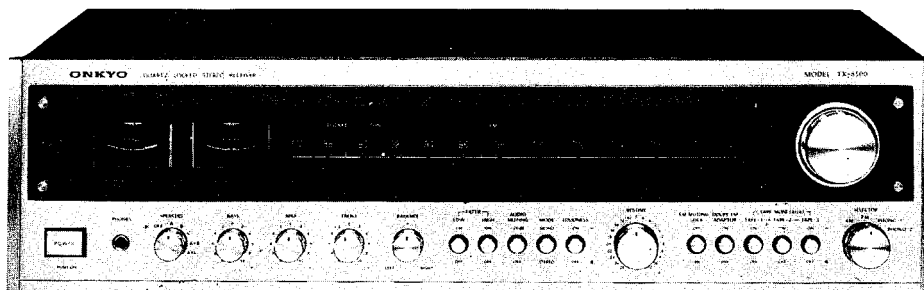

INDEX

Item	Page
Specifications	2
Circuit Description	3
Component Location	4
Block Diagram	5
AM/FM Alignment Procedures	6
Chassis Layout	10
Parts List	11
Service Procedures	12
Stringing Diagram	12
AM/FM Tuner P.C. Board View	13
AM/FM Tuner P.C.B. — Parts List	13
Front End, Equalizer and Tone P.C. Board View	15
Front End, Equalizer and Tone P.C.B. — Parts List	16
Power Amp. P.C. Board View	17
Power Amp. P.C.B. — Parts List	17
Power Amp. Alignment Procedures	18
Rectifier P.C. Board View	19
Rectifier P.C.B. — Parts List	20
Schematic Diagram — Universal model	21
Schematic Diagram — U.S.A. model	25
Packing Procedures	29

ONKYO®
AUDIO COMPONENTS

SPECIFICATIONS

Power Supply Rating	ac 120 volts 60 Hz (U.S.A. model) ac 220 volts 50/60 Hz (Universal model)	Power amp. Tilt	better than 5% at 50 Hz	
Controls	POWER	Sensitivity and Impedance	PHONO: 2.5 mV 50 kohms	
	SPEAKERS (OFF, A, B, C, A+B, A+C)		TAPE PLAY: 150 mV 50 kohms	
Antennas	SELECTOR (AM, FM, PHONO 1, PHONO 2)		TAPE REC: 150 mV	
	TAPE MONITOR 1, 2 & 3		DOLBY OUT: 150 mV 3 kohms	
	TUNING, VOLUME, BALANCE, TREBLE, MID, BASS, DOLBY NR SWITCH, FM MUTING/LOCK SWITCH, LOUDNESS, MODE, FILTER HIGH & LOW, AUDIO MUTING, SENSOR SWITCH (REAR PANEL)	Phono Overload Tone Controller		DOLBY IN: 350 mV (30%) 50 kohms
	FM: 300 ohms balanced and 75 ohms unbalanced	Signal to Noise Ratio		PRE OUT: 1V 3 kohms
	AM: built in ferrite core antenna and external terminal			MAIN IN: 1V 50 kohms
		RIAA Curve Deviation		250 mV RMS at 1 kHz, 0.1% THD.
		Filters		TREBLE: ±10 dB at 10 kHz
		Loudness		MID RANGE: ±5 dB at 1.2 kHz
		Audio Muting		BASS: ±12 dB at 100 Hz
				PHONO: 65 dB (IHF C) 75 dB (IHF A)
Outputs	SPEAKER A, B & C, HEADPHONES TAPE REC OUT 1, 2 & 3, FM DOLBY OUT PRE OUT, FM 4 CH OUT AC OUTLET SWITCHED & UNSWITCHED x 2		TAPE PLAY: 85 dB (IHF C) 90 dB (IHF A)	
Inputs	PHONE 1 & 2, TAPE PLAY 1, 2 & 3, FM DOLBY IN, MAIN IN,			
Dimensions	570 W x 160 H x 455 D mm 22-7/16" x 6-5/16" x 17-15/16"			
Weight	25 kg. 55 lbs.			
Semiconductors	1 FET, 95 Transistors, 8 ICs, 58 Diodes			
Amplifier section				
Power Output (through TAPE)	150 watts per channel, min. RMS, at 4 ohms both channels driven, from 20 Hz to 20 kHz, with no more than 0.1% total harmonic distortion.	Tuner section		
	110 watts per channel, min. RMS, at 8 ohms both channels driven, from 20 Hz to 20 kHz, with no more than 0.1% total harmonic distortion.	Tuning Range	FM: 88 – 108 MHz	
	160 watts per channel min. RMS, at 4 ohms both channels driven, 1 kHz, 0.1% total harmonic distortion.	Usable Sensitivity	AM: 530 – 1605 kHz	
	115 watts per channel min. RMS, at 8 ohms both channels driven, 1 kHz, 0.1% total harmonic distortion	50 dB Quieting Sensitivity	FM mono: 1.7 μV, 9.8 dBf	
Total Harmonic (TAPE) Distortion	0.1% at Rated power	Intermediate Frequency	FM stereo: 4 μV, 17.2 dBf	
IM Distortion (TAPE) (70 Hz: 7 kHz=4:1)	0.08% at 1 watt, 8 ohms	Capture Ratio	FM mono: 3 μV, 14.7 dBf	
Damping Factor	50 (8 ohms, 1 kHz)	Image Rejection Ratio	FM stereo: 35 μV, 36 dBf	
Frequency Response	15 – 30,000 Hz (±1 dB)	IF Rejection Ratio	FM: 10.7 MHz	
	2 – 60,000 Hz (±1 dB at power amplifier)	Spurious Rejection	AM: 455 kHz	
		Signal to Noise Ratio	FM: 1.5 dB	
		Alternate Channel Attenuation	FM: 83 dB	
		AM Suppression Ratio	AM: 55 dB	
		Harmonic Distortion	FM: 100 dB	
		Frequency Response	AM: 55 dB	
		Stereo Separation	FM: 95 dB	
		Muting Level	FM mono: 70 dB	
		Stereo Threshold	FM stereo: 65 dB	
		Quartz Lock Level	AM: 45 dB	
		Sub Carrier	FM: 70 dB	
		Suppression	FM: 70 dB	
			FM: 50 dB	
			FM mono: 0.15%	
			FM stereo: 0.3%	
			AM: 0.8%	
			FM: 30 – 15,000 Hz±1.5dB	
			FM: 40 dB at 1 kHz	
			FM: 32 dB at 70–10,000Hz	
			FM: 4 μV, 17.2 dBf	
			FM: 4 μV, 17.2 dBf	
			FM: 4 μV, 17.2 dBf	
			FM: 60 dB	

Specifications are subject to change without notice.

CIRCUIT DESCRIPTION

1. SPEAKER PROTECTION CIRCUIT

The speaker protection circuit is operated:

- 1) When the B circuit is unstable when the power is turned ON (approximately 5 seconds).
- 2) When the speaker terminals are shorted and abnormal current has flowed in the power amplifier thru this low impedance.
- 3) When the center voltage has increased because of trouble at the differential amplifier, etc.
- 4) When the temperature of the heat sink has risen.

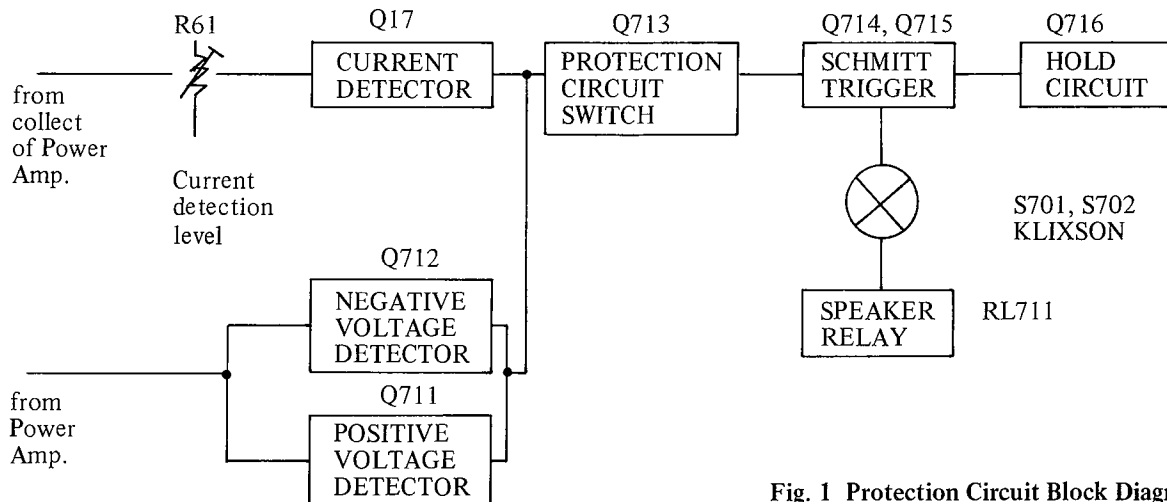

Fig. 1 Protection Circuit Block Diagram

When Q713 is turned on by voltage detection or current detection, Q714 is turned ON by the voltage drop across R719. Q714, Q715 constitute a digitalized, fast response Schmitt trigger circuit. When Q714 is turned ON, Q715 is turned OFF. Q715 is a relay drive transistor. When it is turned OFF, the relay is also turned OFF. The temperature of the heat sink is detected at the collector circuit of Q715 by the Klixson. If the temperature of the heat sink rises excessively, the klixson is turned OFF and the relay is also turned OFF.

When the power switch is turned ON, charging current flows thru the loop R721 → C714 → R718, R719 and Q714 is turned ON by the voltage drop across R719. Consequently, Q715 and the relay are turned OFF until the charging current drops below a certain value. When the power switch is turned OFF, the B voltage falls and C714 is quickly discharged thru the loop C714 → R721 → D711. During normal operation, C714 is charged to almost the B voltage. But since the saturation resistance of Q713 is sufficiently low, when Q713 is turned ON, C714 is quickly discharged thru the loop C714 → R721 → Q713 and the relay is also turned OFF. The relay is not turned ON again thereafter until C714 is charged, even if the set should return to normal and Q713 is turned OFF.

HOLD CIRCUIT

The reference voltage is produced by R726, R727, Q716 is operated as a comparator. When Q715 has been turned OFF, the collector voltage of Q715 rises and C716 is charged. Therefore, when C716 is charged to above a certain voltage relative to the reference voltage at the junction of R726 and R727, Q716 is turned ON, Q713 is turned ON thru R728 and the circuit is held.

CURRENT DETECTOR

Q17 is turned ON by the voltage detected from the collector circuit of the power amplifier. C24 prevents erroneous operation, R61 sets the current detection level and thermister R66 controls changes in the current detection level caused by temperature rise.

When the impedance is low at a certain frequency of the speaker, the protection circuit may be unexpectedly actuated each time a large audio signal of that frequency has entered. However, when this occurs the relay is opened and the power amplifier current returns to normal. The power amplifier current is also automatically returned to normal in a like manner when the load has been inadvertently shorted momentarily.

When connected with the load shorted, the relay is repeatedly turned ON and OFF in load short → relay OFF (no load) → automatic reset (load short current detection) → relay OFF order. Since the OFF time is sufficiently longer than the relay ON time in this case, the voltage across C716 gradually increases until a voltage sufficient to turn Q716 is reached, at which time the relay is held OFF, thus protecting the power transistor against damage by a continuous overcurrent.

VOLTAGE DETECTOR

The voltage detection circuit is an OR circuit consisting of Q711, Q712. First, the Lch and Rch signals are mixed by R711, R712. When this voltage is minus, Q712 is turned ON and when this voltage is plus, Q711 is turned ON and the relay is turned OFF.

Since the center voltage is unrelated to ON-OFF of the load, when an abnormal voltage has been detected, the relay remains off and the hold circuit is operated until the voltage returns to normal. Once the hold circuit has been actuated it is not reset until the power has been turned back on after the cause of the trouble has been corrected.

2. RL701 RELAY

To prevent a rush current from flowing when the power is turned ON, when AC is applied to the transformer thru R701, R702, B voltage is applied, current flows thru the loop R706 → C703 → R707 → R708, Q702 is turned ON and Q701 is turned OFF by the voltage drop across R708 and the relay is turned OFF. When the charging current drops below a certain value, Q702 is turned OFF, the relay is turned ON and the rated voltage is applied to the power transformer.

COMPONENT LOCATION

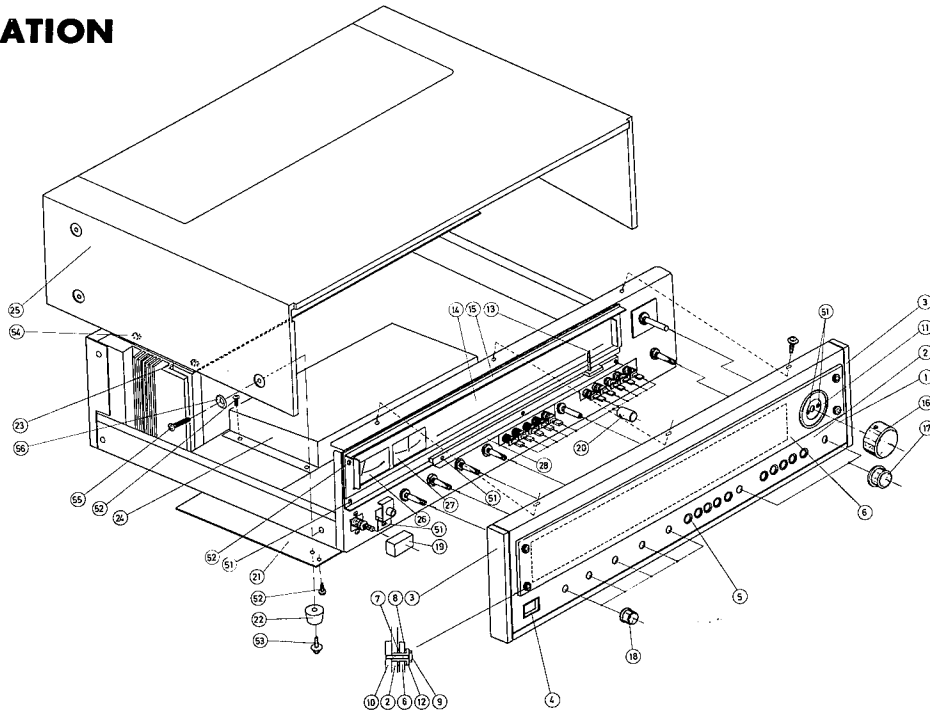
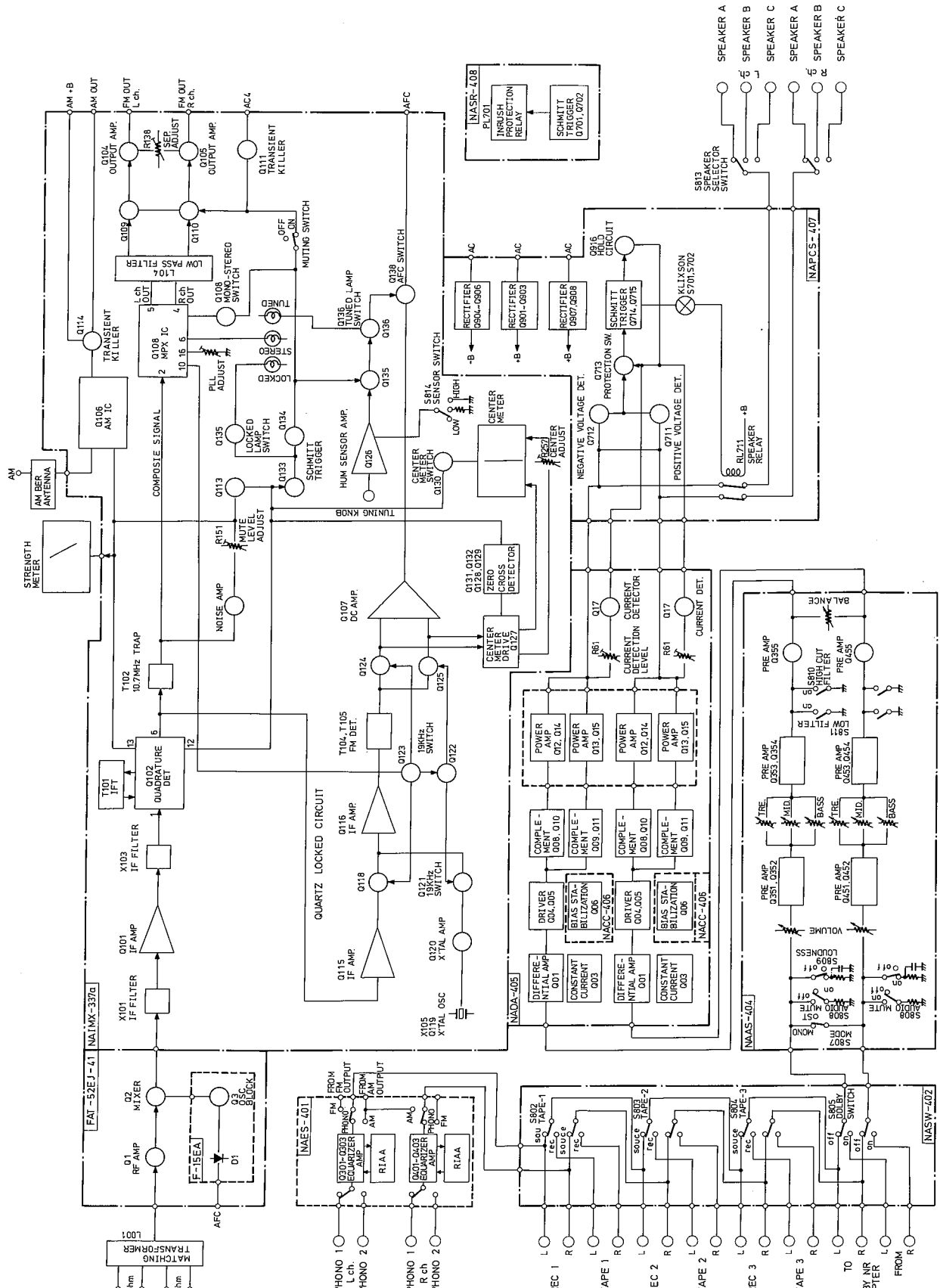

Fig. 2

PARTS LIST

REF. NO.	PARTS NO.	DESCRIPTION	REF. NO.	PARTS NO.	DESCRIPTION
1	13759121	Front Panel Ass'y	18	28320131	Tone Knob
2	27210075	Front Panel	19	28320130	Power Button
3	28125032	End Cap	20	28320133	Push Button
4	27267011	Power Knob Guide	21	27170026	Bottom Board
5	27267010	Push Knob Guide	22	280889	Leg
6	28191018	Dial Glass	23	28184027A	Cover
7	870051	Washer	24	27225016	Shielded Case F
8	870052	Washer	25	28110114	Top Cover (U.S.A. Model)
9	27300038A	Decorative Screw		28110125	Top Cover (Universal Model)
10	27140092	Bracket	26	243054	Strength Meter
11	27265003A	Tuning Ring	27	243055	Center Meter
12	27270014	Spacer	28	27300035	Pointer Rail
13	13829133	Pointer	51	834130062	3STS+6BQ Tapping Screw
	210015	Pointer Lamp 6.3V 0.05AW-3	52	831130082	3STW+8BQ Tapping Screw
14	28130051	Dial Plate	53	831130162	3STW+16BQ Tapping Screw
15	27240013	Dial Plate Bracket	54	834440102	4STS+10BQ(BC) Screw
16	28320136	Tuning Knob	55	82374015	4MW+15BS-Ni Screw
17	28320132	Volume Knob	56	870040	4x12BS-Ni Washer

BLOCK DIAGRAM



ALIGNMENT PROCEDURES

INSTRUMENTS REQUIRED

1. DC Ammeter
2. DC Voltmeter
3. AM/FM Sweep Generator
4. AM/FM Signal Generator
5. Vacuum Tube Voltage Meter (VTVM) AC, DC
6. Oscilloscope
7. Monitorscope
8. Distortion Analyzer
9. Stereo Modulator
10. Frequency Counter

GENERAL ALIGNMENT CONDITIONS

1. Signal input should be kept as low as possible.
2. Standard modulation is 400Hz 30% (AM), 400Hz 100% (FM MONO), pilot 10% sub and main 90% (FM STEREO)
3. Standard knob position
 SPEAKERS A
 TONE & BALANCE Center
 MODE STEREO
 FILTER, LOUD, MUTE/LOCKED, DOLBY,
 TAPE OFF

ATTACHMENT OF DIAL POINTER

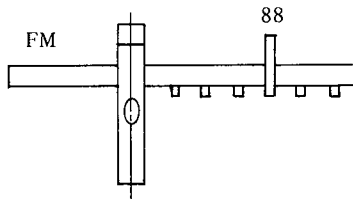
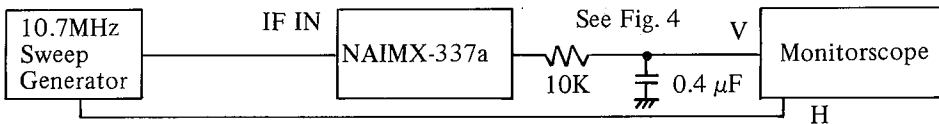

Fig. 3

1. Close the variable capacitor completely.
2. Set the radio dial pointer to zero (0) on dial scale and install the dial pointer ass'y.

QUARTZ LOCKED CIRCUIT ALIGNMENT

Set SELECTOR switch to FM.



10.7MHz Sweep	Adjustment	Adjustment for
10.7MHz	T104, 105	Maximum symmetrical response Fig. 5

Connect Monitorscope

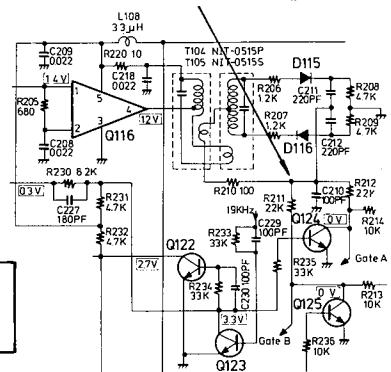

Fig. 4

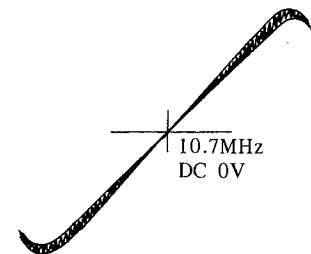
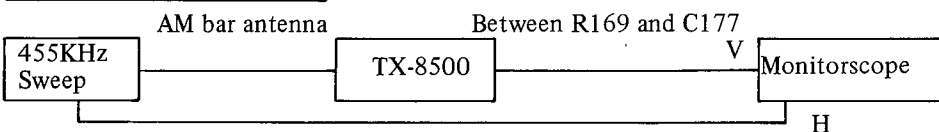

Fig. 5

AM IF ALIGNMENT



Set Radio Dial	Adjust	Adjust for	Remarks
Upper end	X104	Maximum symmetrical response	Usually not necessary to adjust

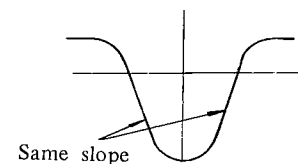
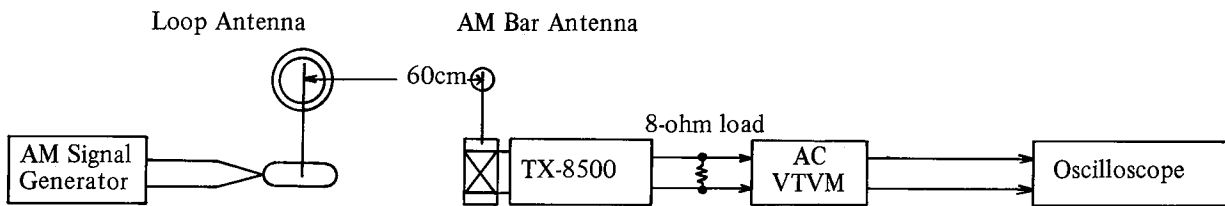

Fig. 6

AM RF ALIGNMENT

Confirm start point of dial pointer before alignment.



Connect AC VTVM across LEFT SPEAKER terminals.

Step	AM Signal Generator	Dial to set	Adjust	AC VTVM reading	Remarks
1	515KHz 400Hz 30% mod.	515KHz Lower end	L105	Maximum	Repeat step 1 and 2 as necessary
2	1680KHz 400Hz 30% mod.	1680KHz Upper end	TC-6	Maximum	
3	600KHz 400Hz. 30% mod.	600KHz	L001 L111	Maximum	Repeat step 3 and 4 as necessary
4	1400KHz 400Hz 30% mod.	1400KHz	TC-2 TC-4	Maximum	

FM FRONT END ALIGNMENT

Set SELECTOR switch to FM.

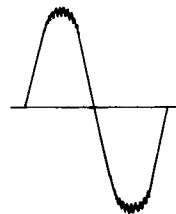
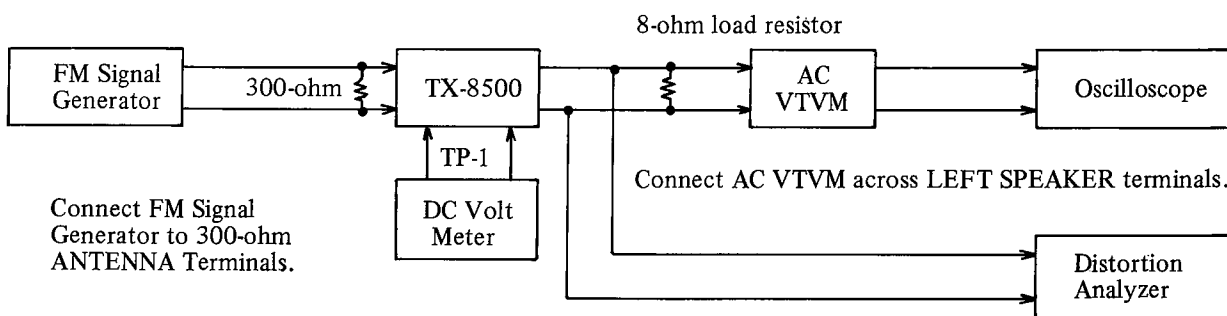
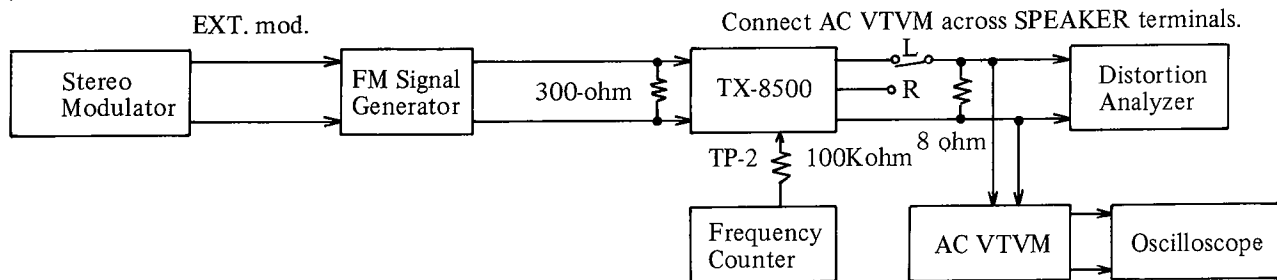

Fig. 7

Step	FM Signal Generator	Dial to set	Adjust	Output Indicator	Adjust for	Remarks
1	No Signal	Quiet Point	T101 Bottom	DC Volt Meter	0mV	
2	98MHz 400Hz 100% mod. 60dB	98MHz	T101 Top	Distortion Analyzer	Minimum Distortion	Set the output voltage to 3V with VOLUME.
3	Repeat step 1 and 2 as necessary.					
4	98MHz 400Hz 100% mod. 60dB	98MHz	R257	TUNING Meter	Center	
5	90MHz 400Hz 100% mod. 60dB	90MHz	OSC Coil L6	DC Volt Meter	0mV	
6	106MHz 400Hz 100% mod. 60dB	106MHz	OSC Trimmer TC7(TCO)	Same as above	0mV	
7	Repeat step 5 and 6 as necessary.					
8	90MHz 400Hz 100% mod.	90MHz	L1 L2 L3	AC VTVM or Oscilloscope	Maximum	
9	106MHz 400Hz 100% mod.	106MHz	TC1 TC3 TC5	Same as above	Maximum	Set FM Signal Generator level as low as possible. Fig. 7
10	Repeat step 8 and 9 as necessary					
11	98MHz 400Hz 100% mod.	98MHz	IC Core Top and Bottom L5	AC VTVM or Oscilloscope	Maximum	

FM MONO DISTORTION AND MULTIPLEX ALIGNMENT



Alignment	Step	FM Signal Generator	Stereo Modulator	Dial to set	Adjust	Output Indicator	Adjust for	Remarks
Mono Distortion		98MHz 400Hz 100% mod. 60dB	—————	98MHz	T101 Bottom	Distortion Analyzer	Minimum	
19KHz	1	98MHz 400Hz No mod. 60dB	—————	98MHz	R142	Frequency Counter	19KHz	
	2	STEREO INDICATOR should light up when stereo program is being received.						
Multiplex	1	98MHz EXT. Mod.	Pilot Sig. 10% Main & Sub Sig. 1KHz Lch 90%	98MHz	R138	AC VTVM Right ch.	Minimum	Repeat step 1 & 2 as necessary
	2	Same as above	Pilot Sig. 10% Main & Sub Sig. 1KHz Rch 90%	98MHz	R138	AC VTVM Left ch.	Minimum	

CENTER METER AND MUTING LEVEL ADJUSTMENT

Set SELECTOR switch to FM.

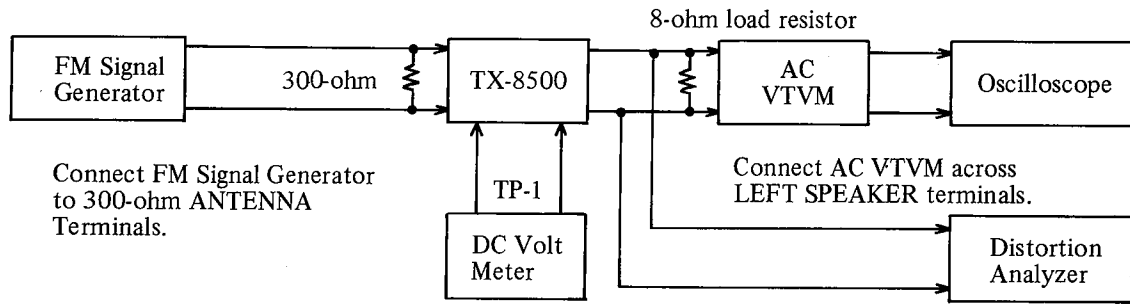

Set TUNING dial pointer and FM Signal Generator Frequency (no mod.) to 98MHz.
Confirm LOCKED LAMP should light up.

Adjustment	FM Signal Generator	Dial to set	Adjust	Output Indicator	Adjust for	Remarks
CENTER METER	98MHz 60dB no mod.	98MHz	R257	TUNING METER	Center	
MUTING	1 98MHz 400Hz 100% mod. 12dB	98MHz	R151	Oscilloscope or AC VTVM	Signal	Repeat step 1 & 2.
	2 11dB				no signal and noise	

ADJUSTMENT POINT

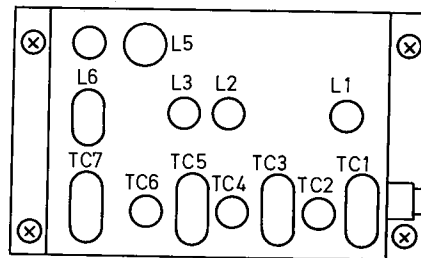

FRONT END
TOP VIEW

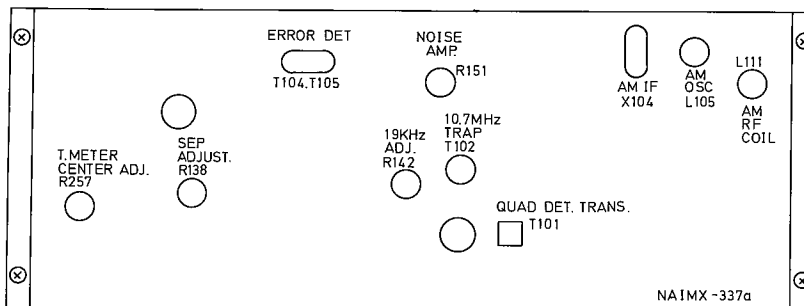

CHASSIS LAYOUT

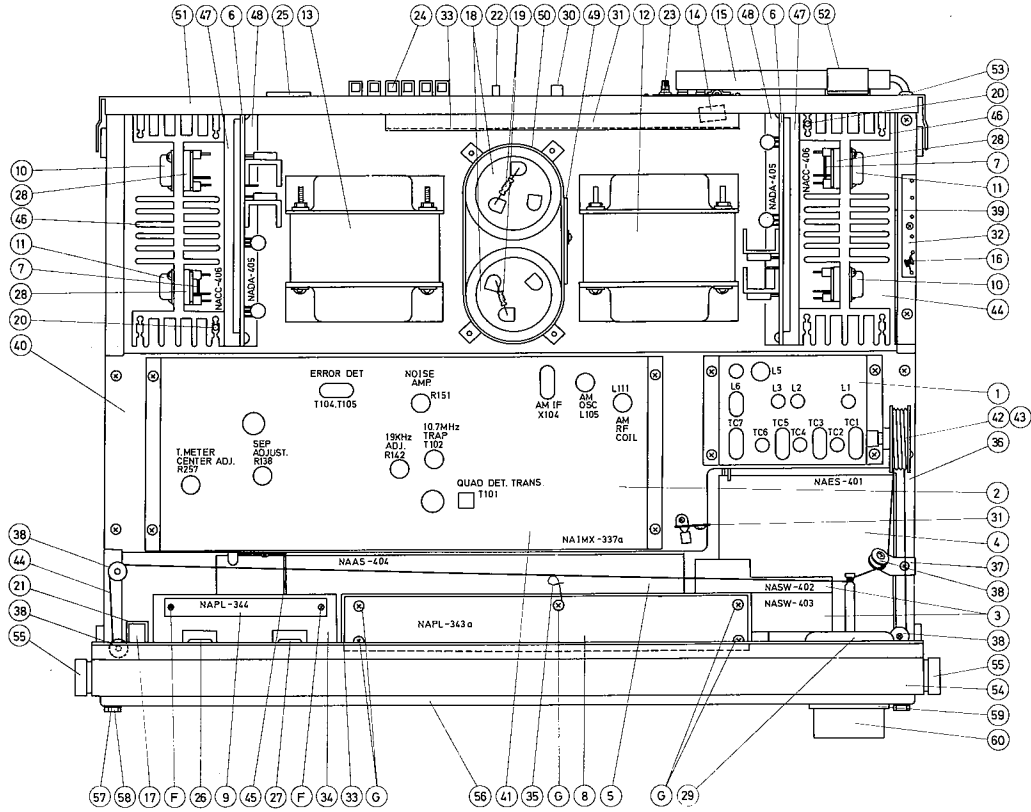

TOP VIEW

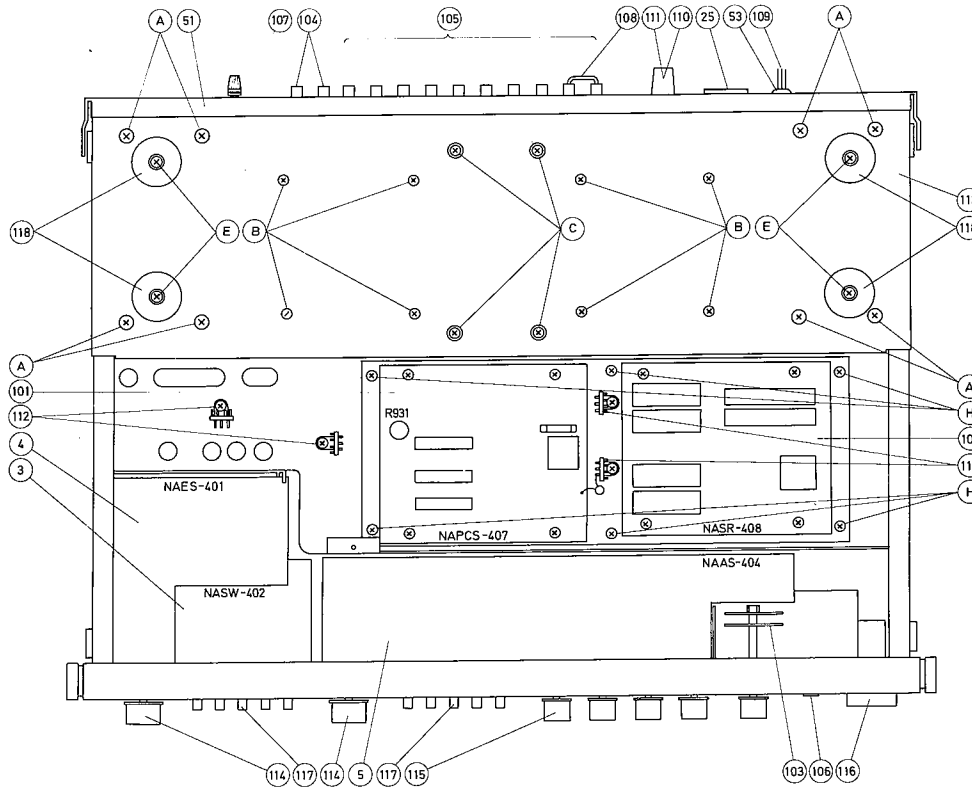

BOTTOM VIEW

PARTS LIST

U.S.A. Model

REF. NO.	PARTS NO.	DESCRIPTION
1	240037	FAT-52EJ-41 Front End
2	13759537A	NAIMX-337a AM/FM Tuner PC Board Complete
3	13759502	NASW-402 Switch PC Board Complete
4	13759501	NAES-401 Equalizer PC Board Complete
5	13759504	NAAS-404 Tone Amp. PC Board Complete
6	13759505	NADA-405 Power Amp. PC Board Complete
7	13759506	NACC-406 Bias Stabilization PC Board Complete
8	13759543A	NAPL-343a Dial Illuminator PC Board Complete
9	13829544	NAPL-344 Meter Lamp PC Board Complete
10	2200532 or 2200533	2SD424(R) or 2SD424(O) or Power Amp. Transistor
11	2200542 or 2200543	2SB554(R) or 2SB554(O) or Power Amp. Transistor
12	230190	NPT-618D Power Transformer
13	230191	NPT-619D Power Transformer
14	233026	NBLN-1 BLN Transformer
15	232061	NMA-1006 AM Bar Antenna
16	233105	NCH-1005 Choke Coil
17	3504012	0.01μF 125V UL Capacitor
18	3504092	10000μF×2 63V Elect. Capacitor
19	441723924	3.9KΩ 2W Metal Oxide Film Resistor
20	252041	9700L-36-11 Klixson
21	25035015	NPS-111LA3 Power Switch
22	25065016	NSS-2327 Hum Sensor Slide Switch
23	25060021B	NTM-3PUM1 Antenna Terminal
24	25060005	NTM-12PUR1 Speaker Terminal
25	25050008	S-16432 AC Outlet
26	243054	NIND-0500S53 Strength Meter
27	243055	NIND-0250S54 Center Meter
28	250249	M-1614 Power Transistor Socket
29	27205005	Drive Shaft
30	250256A	NTM-1WPBL-E1 4CH Det. Output Terminal
31	251065	MD-21 Lug Plate
32	251070	LG-2L Lug Plate
33	27250006A	Lamp Case
34	27300074A	Meter Cover
35	270317	Pointer Lead Clamper
36	27115019A	Side Bracket
37	27140150	Dial Pulley Bracket
38	27185003	Dial Pulley
39	27150059	Shielded Plate B
40	27100021	Front Chassis
41	27225016A	Shielded Case F
42	27200020	Dial Drum
43	273803	SP-14A Dial Drum Spring
44	273903	Dial Cord
45	27150060	Shielded Plate S
46	27160025	Heat Sink
47	27140151	Upper PC Bracket
48	27140152	Lower PC Bracket
49	27190025	Elect. Capacitor Holder
50	27300073	Elect. Capacitor Band
51	27120075A	Back Panel
52	27190021	Antenna Holder
53	270280	Strainrelief
54	13759121	Front Panel Ass'y
55	28125032	End Cap
56	28191018	Dial Glass
57	27270014	Spacer
58	27300038	Decorative Screw
59	27265003A	Tuning Ring
60	28320136	Tuning Knob
101	13759507	NAPCS-407 Rectifier PC Board Complete
102	13759508	NASR-408 Rectifier PC Board Complete
103	25030077	NRS-266-30YW Speaker Selector Switch
104	250170	NTM-2WPBL-E1 Phono Input Terminal
105	250169	NTM-4WPBL-E1 Tape, Dolby, Pre & Main Terminal
106	25045018	LJ-100H Stereo Headphone Jack
107	25060008	Ground Terminal
108	25055015	Shorted Plug
109	253091	10A Power Supply Cord
110	252053	8A(ST-6) Power Fuse
111	250080	S-N1301 Fuse Holder
112	250130	T-4461 Ground Terminal
113	27100022	Back Chassis
114	28320132	Volume Knob
115	28320131	Tone Knob
116	28320130	Power Button
117	28320133	Push Button A
118	280889	Leg

Universal Model

REF. NO.	PARTS NO.	DESCRIPTION
1	240037	FAT-52EJ-41 Front End
2	13759537A	NAIMX-337a AM/FM Tuner PC Board Complete
3	13759502	NASW-402a Switch PC Board Complete
4	13759501	NAES-401 Equalizer PC Board Complete
5	13759504	NAAS-404 Tone Amp. PC Board Complete
6	13759505	NADA-405 Power Amp. PC Board Complete
7	13759506	NACC-406 Bias Stabilization PC Board Complete
8	13759543A	NAPL-343a Dial Illuminator PC Board Complete
9	13829544	NAPL-344 Meter Lamp PC Board Complete
10	2200532 or 2200533	2SD424(R) or 2SD424(O) or Power Amp. Transistor
11	2200542 or 2200543	2SB554(R) or 2SB554(O) or Power Amp. Transistor
12	230207	NPT-618G Power Transformer
13	230208	NPT-619G Power Transformer
14	233026	NBLN-1 BLN Transformer
15	232061	NMA-1006 AM Bar Antenna
16	233105	NCH-1005 Choke Coil
17	3500052	PME271Y510CEE IS Capacitor
18	3504092	10000μF×2 63V Elect. Capacitor
19	441723924	3.9KΩ 2W Metal Oxide Film Resistor
20	252041	9700L-36-11 Klixson
21	25035015	NPS-111LA3 Power Switch
22	25065016	NSS-2327 Hum Sensor Slide Switch
23	25060021B	NTM-3PUM1 Antenna Terminal
24	25060005	NTM-12PUR1 Speaker Terminal
25	none	
26	243054	NIND-0500S53 Strength Meter
27	243055	NIND-0250S54 Center Meter
28	250249	M-1614 Power Transistor Socket
29	27205005	Drive Shaft
30	250256A	NTM-1WPBL-E1 4CH Det. Output Terminal
31	251065	MD-21 Lug Plate
32	251070	LG-2L Lug Plate
33	27250006A	Lamp Case
34	27300074A	Meter Cover
35	270317	Pointer Lead Clamper
36	27115019A	Side Bracket
37	27140150	Dial Pulley Bracket
38	27185003	Dial Pulley
39	27150059	Shielded Plate B
40	27100021	Front Chassis
41	27225016A	Shielded Case F
42	27200020	Dial Drum
43	273803	SP-14A Dial Drum Spring
44	273903	Dial Cord
45	27150060	Shielded Plate S
46	27160025	Heat Sink
47	27140151	Upper PC Bracket
48	27140152	Lower PC Bracket
49	27190025	Elect. Capacitor Holder
50	27300073	Elect. Capacitor Band
51	27120083	Back Panel
52	27190021	Antenna Holder
53	270280	Strainrelief
54	13759121	Front Panel Ass'y
55	28125032	End Cap
56	28191018	Dial Glass
57	27270014	Spacer
58	27300038	Decorative Screw
59	27265003A	Tuning Ring
60	28320136	Tuning Knob
101	13759507	NAPCS-407 Rectifier PC Board Complete
102	13759508	NASR-408 Rectifier PC Board Complete
103	25030077	NRS-266-30YW Speaker Selector Switch
104	250170	NTM-2WPBL-E1 Phono Input Terminal
105	250169	NTM-4WPBL-E1 Tape, Dolby, Pre & Main Terminal
106	25045018	LJ-100H Stereo Headphone Jack
107	20560008	Ground Terminal
108	25055015	Shorted Plug
109	253086	Power Supply Cord AS-CEE-1
109	253088	Power Supply Cord AS-VDE-1 (german model)
110	252020	5A-T Power Fuse
111	250080	S-N1301 Fuse Holder
112	250130	T-4461 Ground Terminal
113	27100022	Back Chassis
114	28320132	Volume Knob
115	28320131	Tone Knob
116	28320130	Power Button
117	28320133	Push Button A
118	280889	Leg

SERVICE PROCEDURES

1. REMOVAL OF THE POWER AMP. PC BOARD

Left ch.

- (1) Remove six screws which hold the top cover to the chassis and lift off the top cover.
- (2) Remove four screws which hold the cover to the heat sink.
- (3) Remove four screws which hold the heat sink to the back chassis.

Right ch.

- (1)-(2) Same as above
- (3) Remove three screws which hold the shielded plate to the side bracket.
- (4) Remove five screws which hold the shielded case to the back panel.
- (5) Remove four screws which hold the heat sink to the back chassis.

NOTES: When removing the power amplifier PCB at the right side, the back panel may contact the Klaxson lead wire and the lead may be damaged.

Therefore, be very careful or unsolder the Klaxson when removing the power amplifier.

2. CHECKING OF THE AM/FM PC BOARD.

- (1) Remove seven screws which hold the bottom board to the front chassis.
- (2) Remove six screws which hold the PC bracket to the front chassis.

3. REPLACING OF THE DIAL LAMP

- (1) Remove six screws which hold the top cover to the chassis and lift off the top cover.
- (2) Remove five screws which hold the lamp PC Board to the lamp case.

4. SCREWS

- | | |
|----------------------------------|--------------------------------|
| A: Heatsink fixed screw | F: Meter lamp PCB. fixed screw |
| B: Power Transformer fixed screw | G: Dial lamp PCB. fixed screw |
| C: Elect. Capacitor fixed screw | H: PC bracket fixed screw |
| E: Leg fixed screw | |

STRINGING DIAGRAM

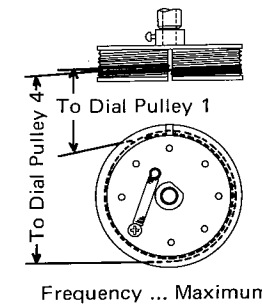

1. Open the variable capacitor complete and tie dial cord to the spring of the drum.
2. Thread dial cord in the direction of arrow from (1) to (3) and wind dial cord three turns around the tuning shaft clockwise.
3. Thread dial cord in the direction of arrow from (4) to (6).
4. Thread dial cord to the Dial Pulley 4.

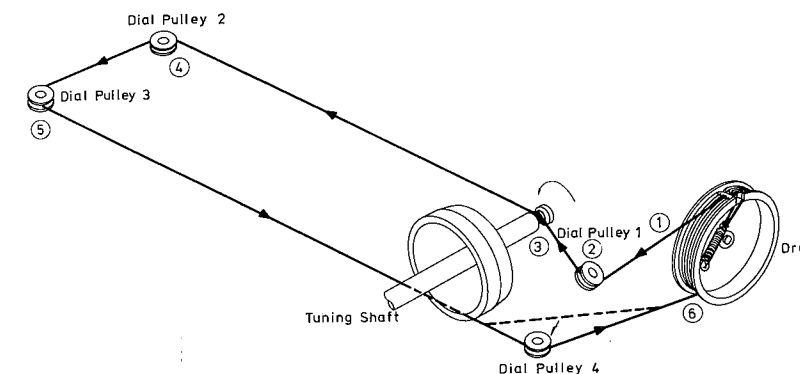

AM/FM TUNER PC BOARD VIEW

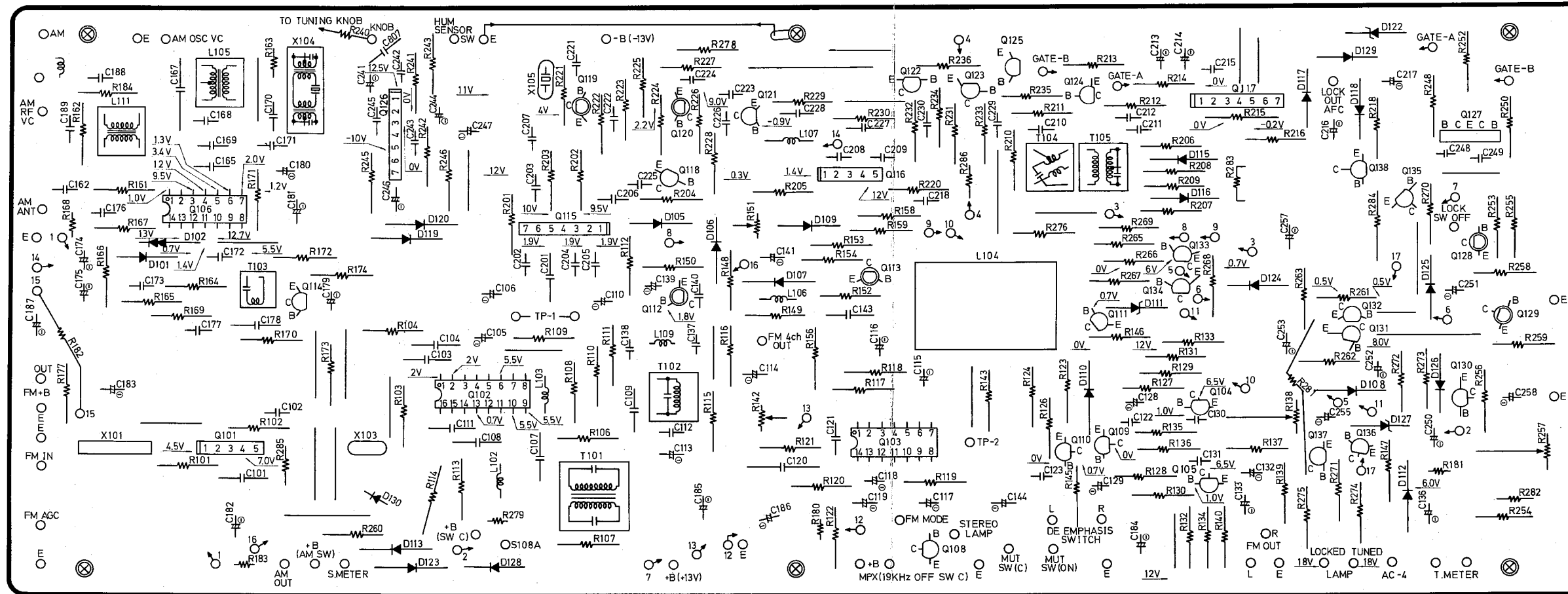

NAIMX-337a
BOTTOM VIEW

AM/FM TUNER PC BOARD-PARTS LIST

CIRCUIT NO.	PARTS NO.	DESCRIPTION	CIRCUIT NO.	PARTS NO.	DESCRIPTION
TRANSISTORS					
Q101	222407	TA-7060P FM IF Amp.	D101, D105		
Q102	222421	HA-1137 Quadrature Det.	D110, D118		
Q103	222419	HA-1156W MPX.	D124, D125	223105	1S1555
Q106	222418	HA-1151 AM	D128		
Q115	222402	TA-7061AP IF Amp.	D102	4000022	VD1212 Varistor
Q116	222407	TA-7060P IF Amp.	D106~D109		
Q117	222424	TA-7504S Differential Amp.	D112~D117		
Q126	222423	TA-7136P Hum Sensor Amp.	D119, D120	2231031	1N60(N)FM
DIODES					
Q104, Q105	2210136	2SC1312(F) MPX Output Amp.	D123, D129		
Q108	2210745	2SC945(L) Q Mono-Stereo Switch	D130		
Q109, Q110	2210943	2SC1317(R) or Muting	D111	223945	RD5.1EB or Zener
	2210244	2SC735(Y) or Muting	D122	224012	WZ-052 or Zener
Q111, Q114	2210745	2SC945(L) Q Transient Killer		223943	RD4.7EB or Zener
Q112, Q113	2210086	2SC733(BL) Muting	D127	224011	YZ-047 or Zener
Q118, Q121	2210943	2SC1317(R) or 19KHz Switch		223948	RD5.6EC or Zener
Q122~Q125	2210244	2SC735 (Y) or 19KHz Switch		223928	WZ-061 or Zener
Q127	2210707	2SC1583(G) Differential Amp.	COILS		
Q128, Q129	2210086	2SC733(BL) Zero Cross Det.	L102	233105	NCH-1005 3.3μH Choke
Q130	2210943	2SC1317(R) Center Meter Switch	L103	233074	NCCH-1506 Choke
Q131, Q132	2210416	2SA726(F) Zero Cross Det.	L104	233104	NMC-5001 or Low Pass Filter
Q133, Q134	2210943	2SC1317(R) or Schmitt Trigger	L105	233032	NMC-8-7 or Low Pass Filter
	2210244	2SC735(Y) or Schmitt Trigger	L106	232064	NMO-2001 AM OSC
Q135, Q136	Same as above	Same as above Lamp Switch	L107	233031	NMC-9-1
Q137, Q138	Same as above	Same as above Lamp Switch	L109	233024	NCCH-1501 3.3μH Choke
Q119, Q120	2210123	2SC380(O) x 4al osc.	L111	233018	NMC-4-11 MPX Coil
				232043	NMRF-2503 AM RF

CIRCUIT NO.	PARTS NO.	DESCRIPTION
TRANSFORMERS		
T101	233101	NFIF6003
	233083	NIT3516
T102	233084	NIT-0517
T103	232041	NIT-0509
T104	233078	NIT-0515P
T105	233079	NIT-0515S
CERAMIC FILTERS		
X101	3010018	SFJ10.7MA(RED) FM IF
X103	3010006	SFE10.7MA(RED) FM IF
X104	3010012	CFT-455B AM IF
X'TAL		
X105	3010015	XTL-10.7M 10.7MHz OSC
CAPACITORS		
C105	352750471	4.7μF 25V Elect.
C106	352784791	0.47μF 50V Elect.
C110	352780101	1μF 50V Elect.
C113, C114	352741001	10μF 16V Elect.
C115, C116	352780221	2.2μF 50V Elect.
C117, C118	392884797	0.47μF±20% 50V LL
C119	392880107	1μF±20% 50V LL
C120	372325114	510pF±5% 50V ST
C121	374124737	0.047μF±20% 50V DE
C128, C129	352780101	1μF 50V Elect.
C132, C133	392882297	0.22μF±20% 50V LL
C136	392041007	10μF 16V MS
C139	352780101	1μF 50V Elect.
C141	352741001	10μF 16V Elect.
C144	352741011	100μF 16V Elect.
C167	372323615	360pF±10% 50V ST

CIRCUIT NO.	PARTS NO.	DESCRIPTION
CAPACITORS		
C174	352780101	1μF 50V Elect.
C175	352780331	3.3μF 50V Elect.
C178	374124737	0.047μF ±20% 50V DE
C179	352751001	10μF 25V Elect.
C180	352741001	10μF 16V Elect.
C181, C183	352741011	100μF 16V Elect.
C186		
C182, C187	352744701	47μF 16V Elect.
C184	352742211	220μF 16V Elect.
C185	352744711	470μF 16V Elect.
C213, C214	392884797	0.47μF ±20% 50V LL
	392084797	0.47μF ±20% 50V MS
C216	352744701	47μF 16V Elect.
C217, C241	352780101	1μF 50V Elect.
C244	352741001	10μF 16V Elect.
C246	352784791	0.47μF 50V Elect.
C247	352741001	10μF 16V Elect.
C250	352780331	3.3μF 50V Elect.
C251~C253	352741001	10μF 16V Elect.
C255	352780101	1μF 50V Elect.
C257	352744711	470μF 16V Elect.
C258	352744701	47 μF 16V Elect.
VARIABLE RESISTORS		
R138	5225018	R-HK1KB3P Sep. Adjust
R142	5225019	N10HR4.7KBD VCO. Adjust
R151	5225016	R-HK100KB3M Mute. Level
R257	5225055	N10HR2KBC Tuning Meter Center Adjust
RESISTORS		
R274	441622214	220Ω 1W Metal Oxide Film
R275	441622714	270Ω 1W Metal Oxide Film

tone amp. pc board view

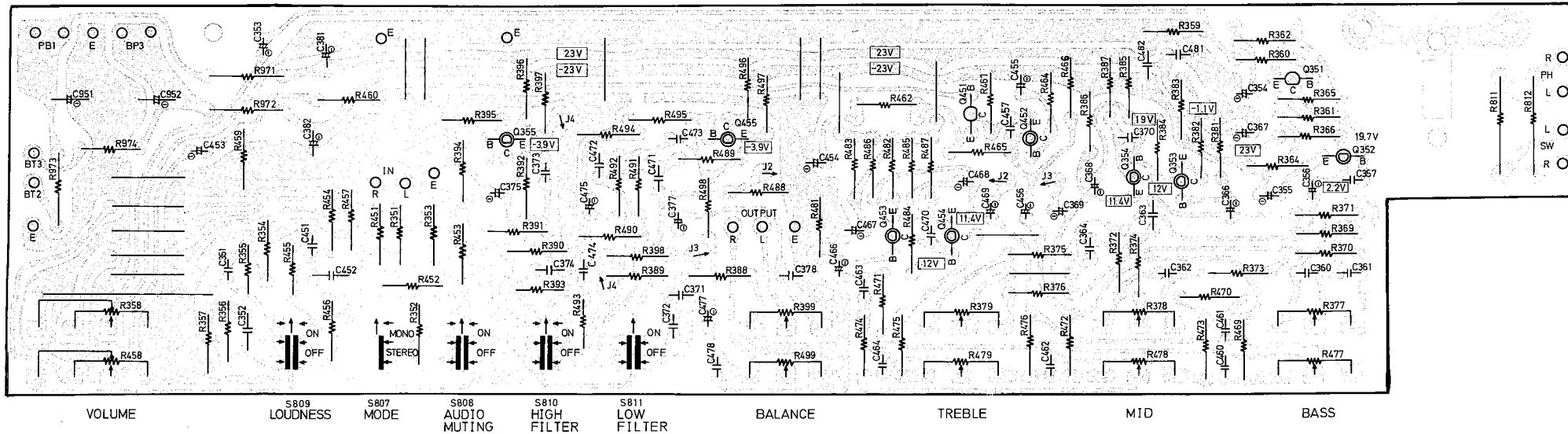

**NAAS-404
BOTTOM VIEW**

EQUALIZER AMP. PC BOARD VIEW

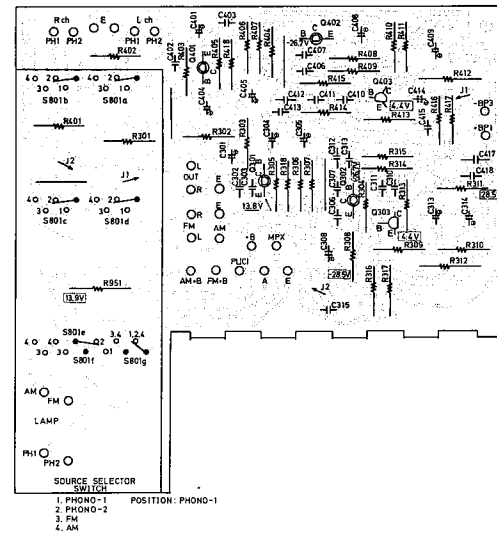

**NAES-401
BOTTOM VIEW**

EQUALIZER AMP. PC BOARD - PARTS LIST

CIRCUIT NO.	PARTS NO.	DESCRIPTION
TRANSISTORS		
Q301, Q401	2210665 or 2210666	2SA841(GR) or Equalizer Amp.
Q302, Q402	2210670 or 2210671	2SC1681(0-1) or Equalizer Amp.
Q303, Q403	2211063 or 2211064	2SC1509(R) or Equalizer Amp.
CAPACITORS		
C301, C401	392680221	2.2μF 50V LR
C304, C404	352734701	47μF 10V Elect.
C305, C405	352741001	10μF 16V Elect.
C308, C408	352721011	100μF 6.3V Elect.
C309, C409	352753301	33μF 25V Elect.
C314, C414	392684791	0.47μF 50V LR
RESISTORS		
R312, R412	441623324	3.3KΩ 1W Metal Oxide Film
R951	441622714	270Ω 1W Metal Oxide Film
ROTARY SWITCH		
S801	25030076	NRS-374-30A Source Selector

tone amp. pc board - PARTS LIST

CIRCUIT NO.	PARTS NO.	DESCRIPTION
TRANSISTORS		
Q351, Q451	2210666, 2210916 or 2210417	2SA841(BL), 2SA722(T) or Preamp.
Q352~Q355, Q452~Q455	2210670 or 2210671	2SC1681(O-1) or Preamp.
CAPACITORS		
C353, C453	392680221	2.2μF 50V LR
C354, C355	352721011	100μF 6.3V Elect.
C454, C455	352780471	4.7μF 50V Elect.
C356, C456	352780221	2.2μF 50V Elect.
C367, C467	352733301	33μF 10V Elect.
C368, C468	352751001	10μF 25V Elect.
C374, C474	372328214	820pF ±5% 50V ST
C375, C475	392684791	0.47μF 50V LR
C377, C477	352780101	1μF 50V Elect.
C381, C382	352753311	330μF 25V Elect.
C951, C952	352764711	470μF 35V Elect.
VARIABLE RESISTORS		
R358, R458	5172047	N24RGL41C100KBTP30 VOLUME
R377, R477		BASS
R378, R478	5172044	N24RGP100KB30-21C MIDDLE
R379, R479		TREBLE
R399, R499	5172043	N24RGP100KMN30-C BALANCE
RESISTORS		
R811, R812	441723314	330Ω 2W Metal Oxide Film
SWITCHES		
S807~S811	25035053	NPS-522-L18 MODE/LOUD/MUTE./FILTER

FRONT END PC BOARD VIEW

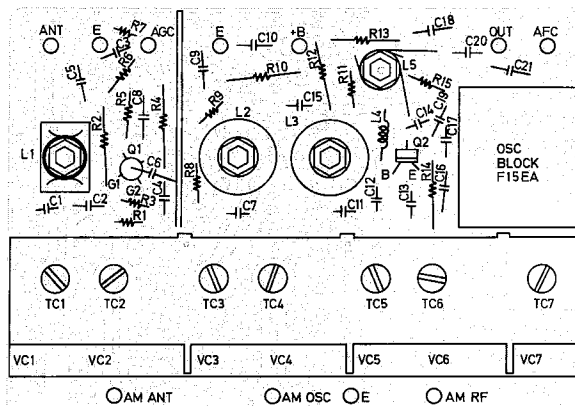

FRONT END PC BOARD - PARTS LIST

CIRCUIT NO.	PARTS NO.	DESCRIPTION
TRANSISTORS		
Q1	3SK45(B)	
Q2	2SC535(B)	
OSC BLOCK		
222013	F-15EA	

SWITCH PC BOARD - PARTS LIST

CIRCUIT NO.	PARTS NO.	DESCRIPTION
R961~R964	441622714	270Ω 1W Metal Oxide Film
SWITCHES		
S802~S806	25035052	NPS-562-L17 TAPE, DOLBY, FM MUTING

**FAT-52EJ-41
BOTTOM VIEW**

NOTES:

- DE: Non-Inductive Polyester Film Capacitor.
- LD, SLD: Low Leakage Current Type Electrolytic Capacitor.
- ST: Polystyren Film Capacitor.

POWER AMP. PC BOARD VIEW

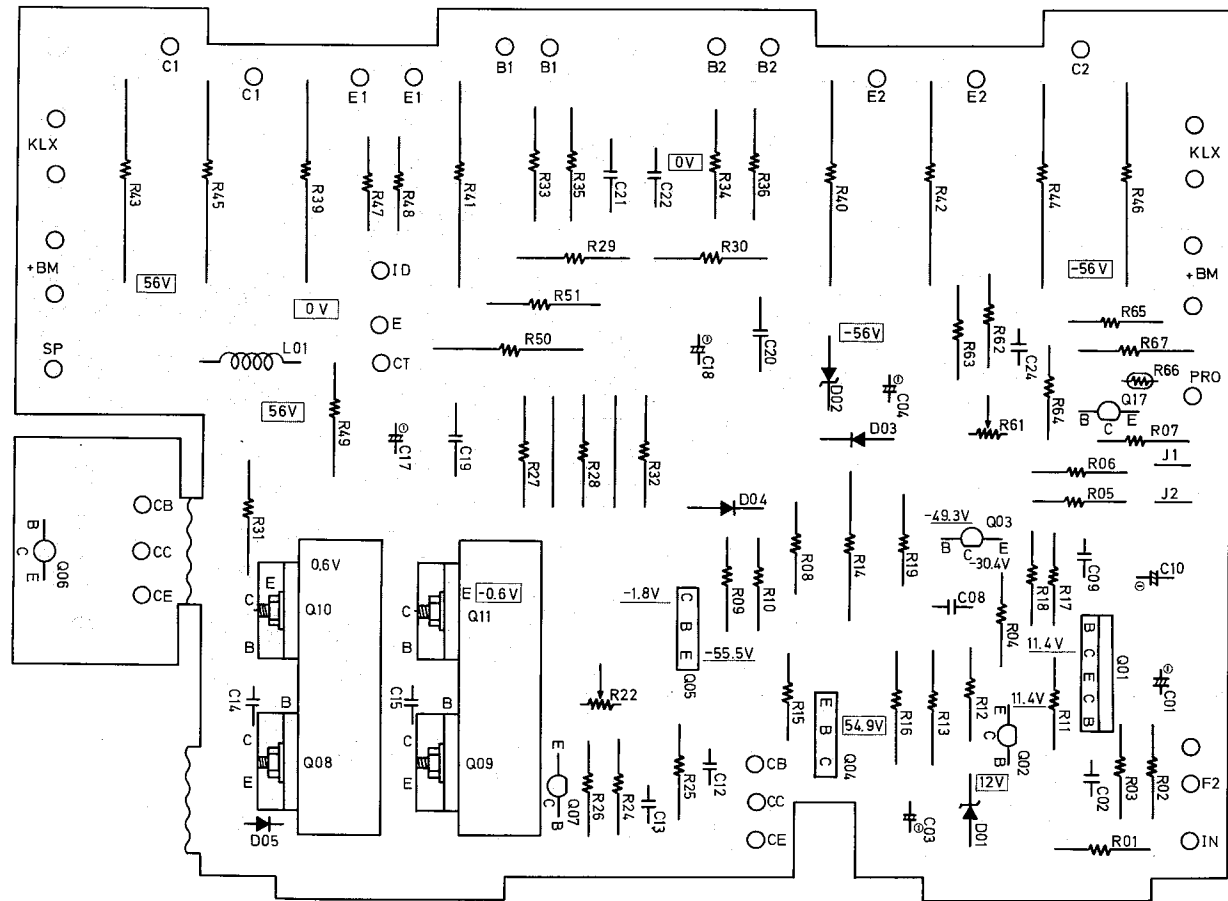

NADA-405
BOTTOM VIEW

POWER AMP. PC BOARD - PARTS LIST

CIRCUIT NO.	PARTS NO.	DESCRIPTION	CIRCUIT NO.	PARTS NO.	DESCRIPTION
TRANSISTORS					
Q01	2210700	2SC1583(O-001) Differential Amp.	L01	231001	S-1.3B
Q02	2210755	2SC1775A(E) Driver	CAPACITORS		
Q03	2210795	2SC1890A(E) Regulator Current	C01	392651001	10μF 25V LR
Q04	2210774	2SA818(Y) Driver	C03, C10	352744701	47μF 16V Elect.
Q05	2210784	2SC1628(Y) Driver	C17, C18	352771001	10μF 63V Elect.
Q07	2211183	2SC1740(R) Complement	C22	374131045	0.1μF ±10% 100V DE
Q08	2210782	2SC1628(O) Complement	RESISTORS		
	2210784	2SC1628(Y) Complement	R13	441628224	8.2KΩ 1W Metal Oxide Film
Q09	2210772	2SA818(O) Complement	R14	441721534	15KΩ 2W Metal Oxide Film
	2210774	2SA818(Y) Complement	R29, R30	441624704	47Ω 1W Metal Oxide Film
Q10	2200552	2SC1669(O) Complement	R31, R32	451631004	10Ω 1W Metal
	2200553	2SC1669(Y) Complement	R33~R36	451630274	2.7Ω 1W Metal
Q11	2200562	2SA839(O) Complement	R39~R42	48114795	0.47Ω 5W Cement
	2200563	2SA839(Y) Complement	R43~R46	48193395	0.33Ω 3W Cement
Q12, Q14	2200532	2SD424(R) Power Amp.	R49	451630684	6.8Ω 1W Metal
	2200533	2SD424(O) Power Amp.	R50	451731004	10Ω 2W
Q13, Q15	2200542	2SB554(R) Power Amp.	R66	4000003	D22A Termistor
	2200543	2SB554(O) Power Amp.	VARIABLE RESISTORS		
Q17	2210795	2SC1890A(E) Current Detector Amp.	R22	5221017	R-HK1KB3S
DIODES					
D01	223910	WZ-120 Zener	R61	5221007	R-HK2.2KB3S
D02	223928	WZ-061 Zener	HEAT SINK		
D03, D04	4000031	M8513A(O) Varistor	27160011	RAD-05	
D05	223105	1S1555			

POWER AMP. ALIGNMENT PROCEDURES

IDLING CURRENT ADJUSTMENT

Connect the DC voltmeter between ID-CT terminals.
Adjust the voltage to 40 + 10mV with R22.
NOTES: Adjust after switching on for 10 minutes.
Open Load Volume ... Minimum

CURRENT DETECTOR LEVEL ADJUSTMENT

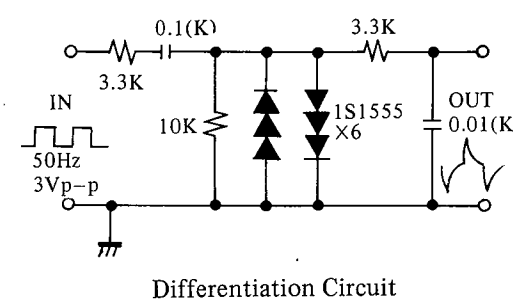
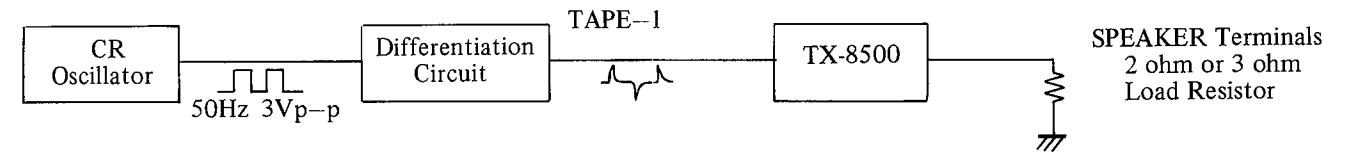

NOTES: Adjust after switching on for 10 minutes.
VOLUME - Maximum

Apply a tone burst signal to the TAPE-1 terminal, connect a 2 ohm hollow resistor to the speaker terminals and adjust variable resistor R61 so that the relay is operated at maximum volume. Confirm that the relay is not operated when the 3 ohm hollow resistor is connected.

CENTER VOLTAGE CHECK

When the transistor of the differential amp (Q1) of the power amplifier (NADA-405) or the constant current circuit (Q3) has been replaced, check the center voltage.

(Check method)

Connect a DC VTVM between the CT-E terminals and check if the reading of the DC VTVM is within 30mV of the rated voltage.

When outside the rated voltage, cut or connect the jumper wires (J1, J2) by referring to the below table. Perform this check 10 minutes after the power switch has been set to ON.

J1	J2	Center Voltage
Connect	Connect	0mV
Connect	Cut	-9 ~ -13mV
Cut	Connect	-18 ~ -22mV
Cut	Cut	-34 ~ -38mV

The center voltage when jumpers J1, J2 are connected was assumed to be 0mV.

28.5 VOLT LINE ADJUSTMENT

Connect the DC Voltmeter between PL1 and E terminals.
Adjust the voltage to 28.5 Volt with R931.

RECTIFIER PC BOARD VIEW

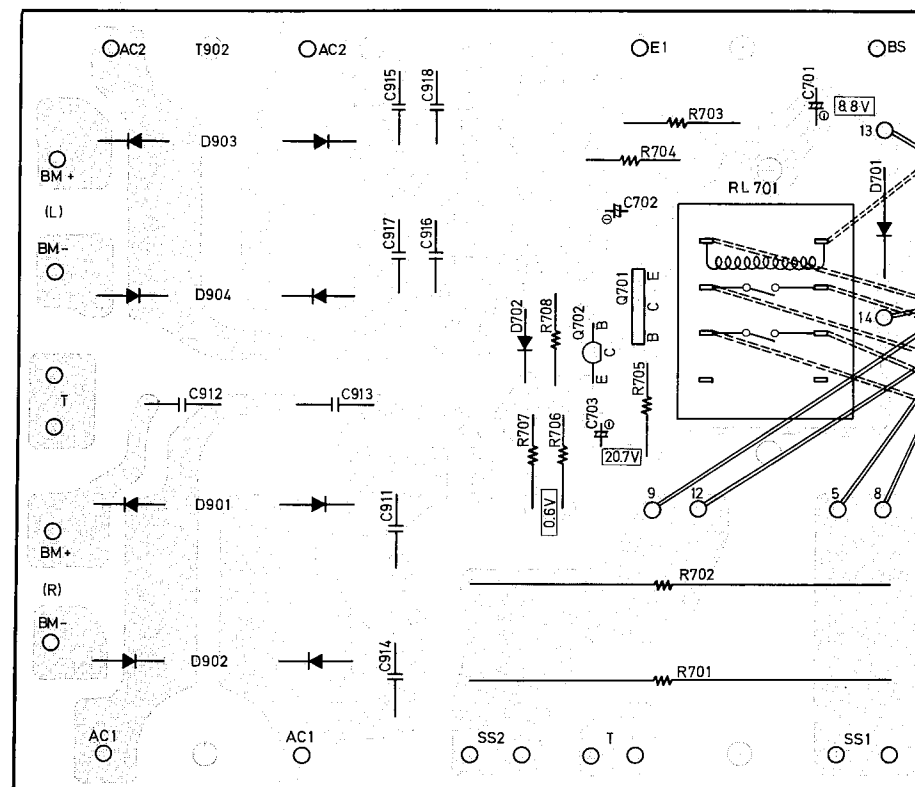
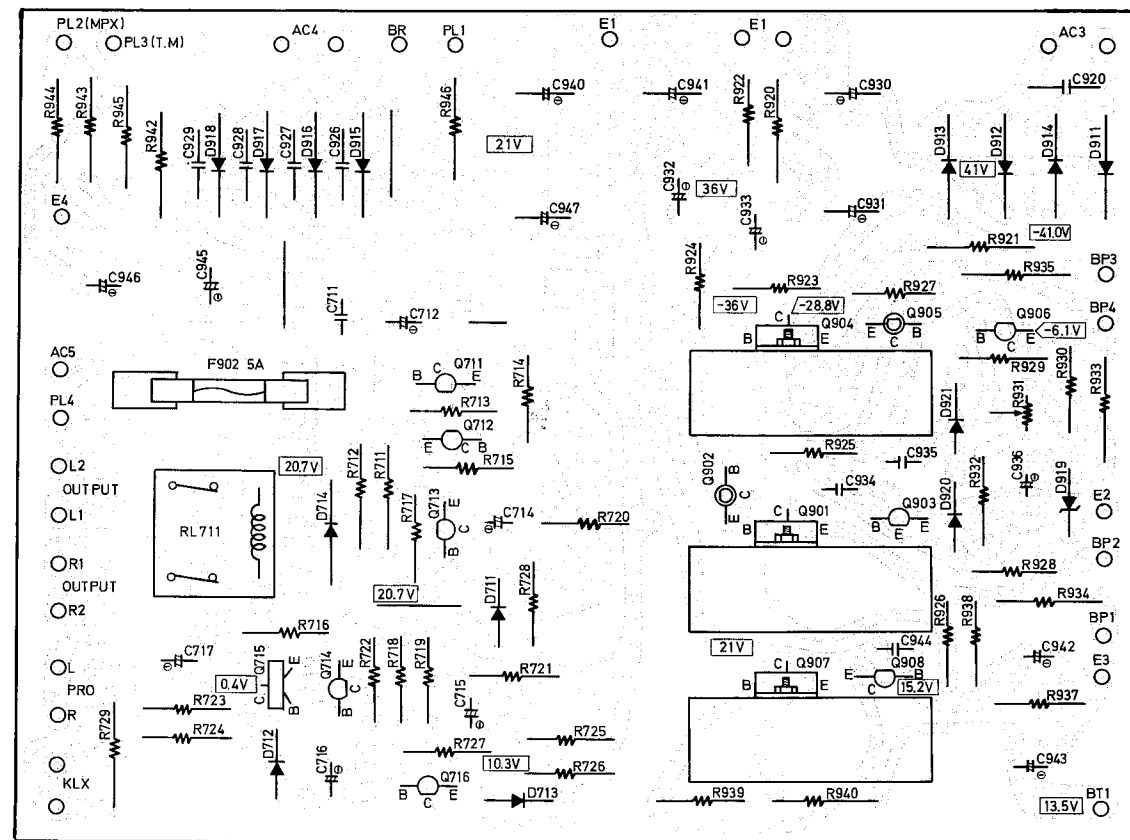

NASR-408
BOTTOM VIEW

NAPCS-407
BOTTOM VIEW

RECTIFIER P.C.B. – PARTS LIST

CIRCUIT NO.	PARTS NO.	DESCRIPTION	CIRCUIT NO.	PARTS NO.	DESCRIPTION
TRANSISTORS					
Q711, Q712	2211183 or 2211184	2SC1740(R) or 2SC1740(S) Voltage det.	C714	352753301	33μF 25V Elect.
Q713	2210416 or 2210417	2SA726(F) or 2SA726(G) Protection Switch	C715	352780331	3.3μF 50V Elect.
Q714	2211183 or 2211184	2SC1740(R) or 2SC1740(S) Schmitt Trigger	C716	352741011	100μF 16V Elect.
Q715	2210863 or 2210864	2SC1212AWT(C) or 2SC1212AWT(D) Schmitt Trigger	C717	352753301	330μF 25V Elect.
Q716	2211183 or 2211184	2SC1740(R) or 2SC1740(S) Hold Circuit	C930, C931	352783311	330μF 50V Elect.
Q901, Q904	2200113 or 2200020	2SD234(O) or 2SD234(Y) Rectifier	C932, C933	352783301	33μF 50V Elect.
Q902	2210670 or 2210671	2SC1681(O-1) or 2SC1681(O-2) Rectifier	C936	352734701	47μF 10V Elect.
Q903, Q908	2211183 or 2211184	2SC1740(R) or 2SC1740(S) Rectifier	C940, C941	352754711	470μF 25V Elect.
Q905	2210665 or 2210666	2SA841(GR) or 2SA841(BL) Rectifier	C942	352744701	47μF 16V Elect.
Q906	2210416 or 2210417	2SA726(F) or 2SA726(G) Rectifier	C943	352743311	330μF 16V Elect.
Q907	2200013 or 2200014	2SD235(O) or 2SD235(Y) Rectifier	C945	352752211	220μF 25V Elect.
DIODES					
D711~D713	223105	1S1555	C946	352753311	330μF 25V Elect.
D714	223802	1S1885	C947	352754711	470μF 25V Elect.
D911~D914	223806	1S1886	RESISTORS		
D915~D918	223802	1S1885	R720	441623314	330Ω 1W Metal Oxide Film
D919	223928	WZ-061 Zener	R729	441621214	120Ω 1W Metal Oxide Film
D920, D921	223105	1S1555	R942	441621014	100Ω 1W Metal Oxide Film
CAPACITORS					
C712	352724711	470μF 6.3V Elect.	R943	441621514	150Ω 1W Metal Oxide Film
VARIABLE RESISTOR					
R931 5225005 R-HK2.2KB Voltage Adjustment					
FUSE					
F902 252020 5A-T					
FUSE HOLDER					
F902a 250113 SN5051					
RELAY					
RL711 250166 NRS2P5A-DC12 Speaker					
RADIATOR					
27160011					

RECTIFIER P.C.B. – PARTS LIST

CIRCUIT NO.	PARTS NO.	DESCRIPTION	CIRCUIT NO.	PARTS NO.	DESCRIPTION
TRANSISTORS					
Q701	2210863 or 2210864	2SC1212AWT(C) or 2SC1212AWT(D) Schmitt Trigger	C701	352733311	330μF 10V Elect.
Q702	2211183 or 2211184	2SC1740(R) or 2SC1740(S) Schmitt Trigger	C702	352780331	3.3μF 50V Elect.
DIODES					
D701	223802	1S1885	C703	352780101	1μF 50V Elect.
D702	223105	1S1555	RESISTORS		
D901, D903	223819	S5151	R701, R702	4000033	3.9Ω 10W Fuse
D902, D904	223820	S5151R	R703	441621214	120Ω 1W Metal Oxide Film
RELAY					
RL701 25065030 NRL-2P5ADC12-01					

DIAL LAMP P.C.B. – PARTS LIST

CIRCUIT NO.	PARTS NO.	DESCRIPTION	CIRCUIT NO.	PARTS NO.	DESCRIPTION
PL801~PL804	210026	250mA 6.3V Dial Lamp	RELAY		
PL808~PL814	210027	50mA 6.3V Indicator Lamp	RL701 25065030 NRL-2P5ADC12-01		
PL816~PL819	210027	50mA 6.3V Indicator Lamp	RESISTORS		
	250113	SN5051 Fuse Holder	27140082 Lamp Bracket		
			27190014 Lamp Holder		
			27140104 Bracket		

METER LAMP P.C.B. – PARTS LIST

CIRCUIT NO.	PARTS NO.	DESCRIPTION
PL805, PL806	210026	250mA 6.3V Meter Lamp
	250113	SN5051 Fuse Holder

BIAS STABILIZATION PC BOARD – PARTS LIST

CIRCUIT NO.	PARTS NO.	DESCRIPTION
TRANSISTOR		
Q06	2211183 or 2211184	2SC1740(R) or 2SC1740(S) or Bias Stabilization

NOTES:

DE: Non-Inductive Polyester Film Capacitor
 LD: Low Leakage Current Type Electrolytic Capacitor
 SLD: Low Leakage Current Type Electrolytic Capacitor
 ST: Polystyren Film Capacitor
 NP: Non-polar Electrolytic capacitor
 When replacing differential amplifier or push-pull amplifier transistors, be sure that transistors of one channel have the same h_{FE} ratings.

AM/FM TUNER SCHEMATIC DIAGRAM

UNIVERSAL MODEL

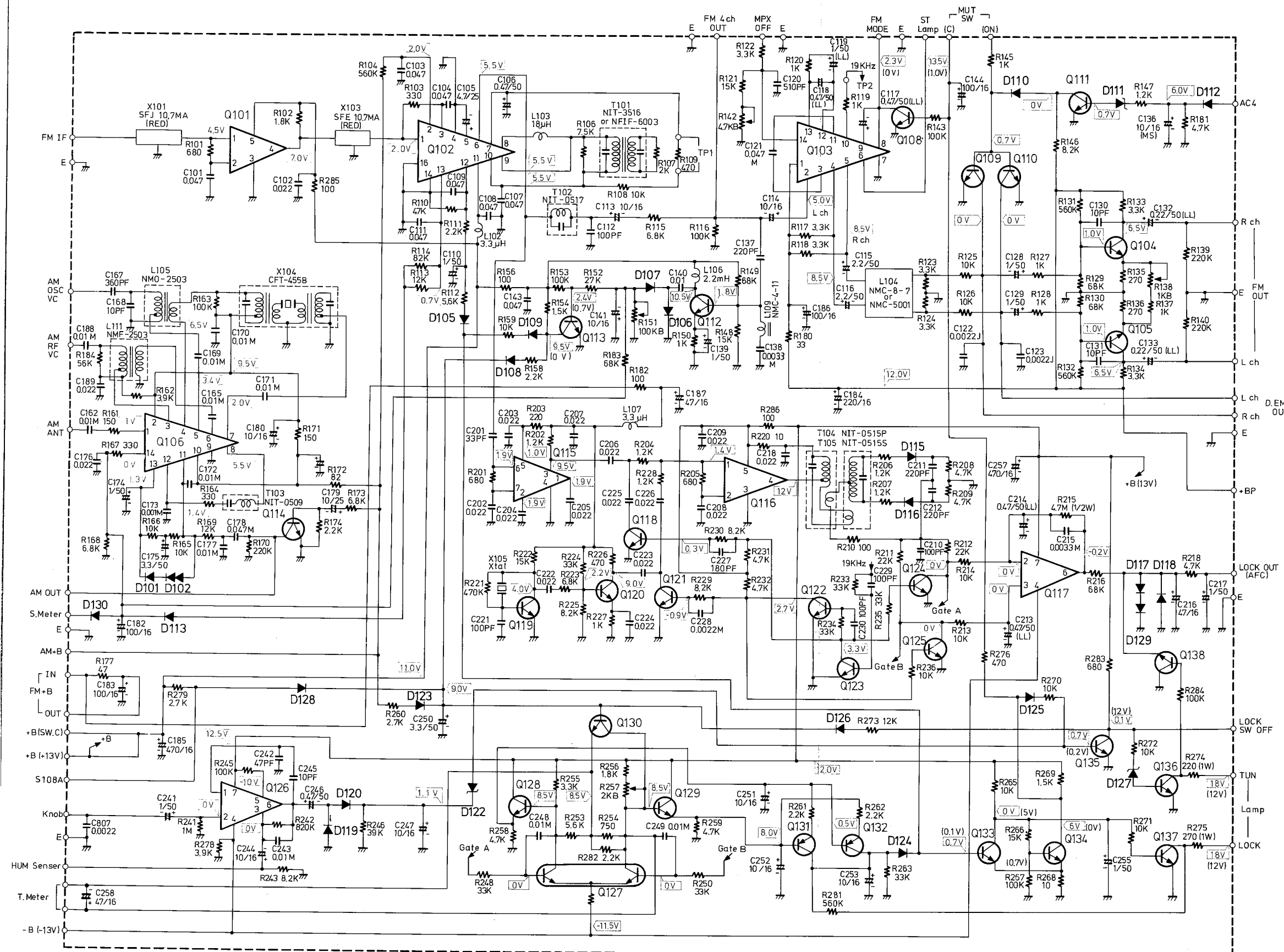

- Q101, Q116----- TA7060P
- Q102----- HA1137
- Q103----- HA1156W
- Q104, Q105----- 2SC1312(F)
- Q106----- HA1151
- Q108, Q111, Q114----- 2SC945(Q or 2SC732(B) or(GR)
- Q109, Q110, Q118, Q130----- 2SC1317(R) or 2SC735(Y)
- Q121-Q125, Q133-Q138----- 2SC733(BL)
- Q112, Q113, Q128, Q129----- 2SC733(BL)
- Q115----- TA7061AP
- Q117----- TA7504S
- Q119, Q120----- 2SC380(O)
- Q126----- TA7136P
- Q127----- 2SC1583G
- Q131, Q132----- 2SA726(F)

- D101, D105, D110, D118----- 1S1555
- D124, D125, D128----- VD1212
- D102----- VD1212
- D106-D109, D112-D117----- 1N60
- D119, D120, D123, D126----- 1N60
- D129, D130----- 1N60
- D111----- WZ051 or RD5.1EB
- D122----- YZ047 or RD4.7EB
- D127----- WZ061 or RD5.6EC

NOTES

- ALL RESISTORS ARE IN OHMS, 1/4 WATT UNLESS OTHERWISE NOTED.
- ALL CAPACITORS ARE IN μ F, 500VW UNLESS OTHERWISE NOTED.
- ELECTROLYTIC CAPACITORS (—|—) ARE IN μ F/WV.
- VOLTAGE (MEASURED WITH V.T.V.M.)
- V DC VOLTAGE (NO INPUT SIGNAL).
- V DC VOLTAGE (FM STEREO).

SCHEMATIC DIAGRAM

UNIVERSAL MODEL

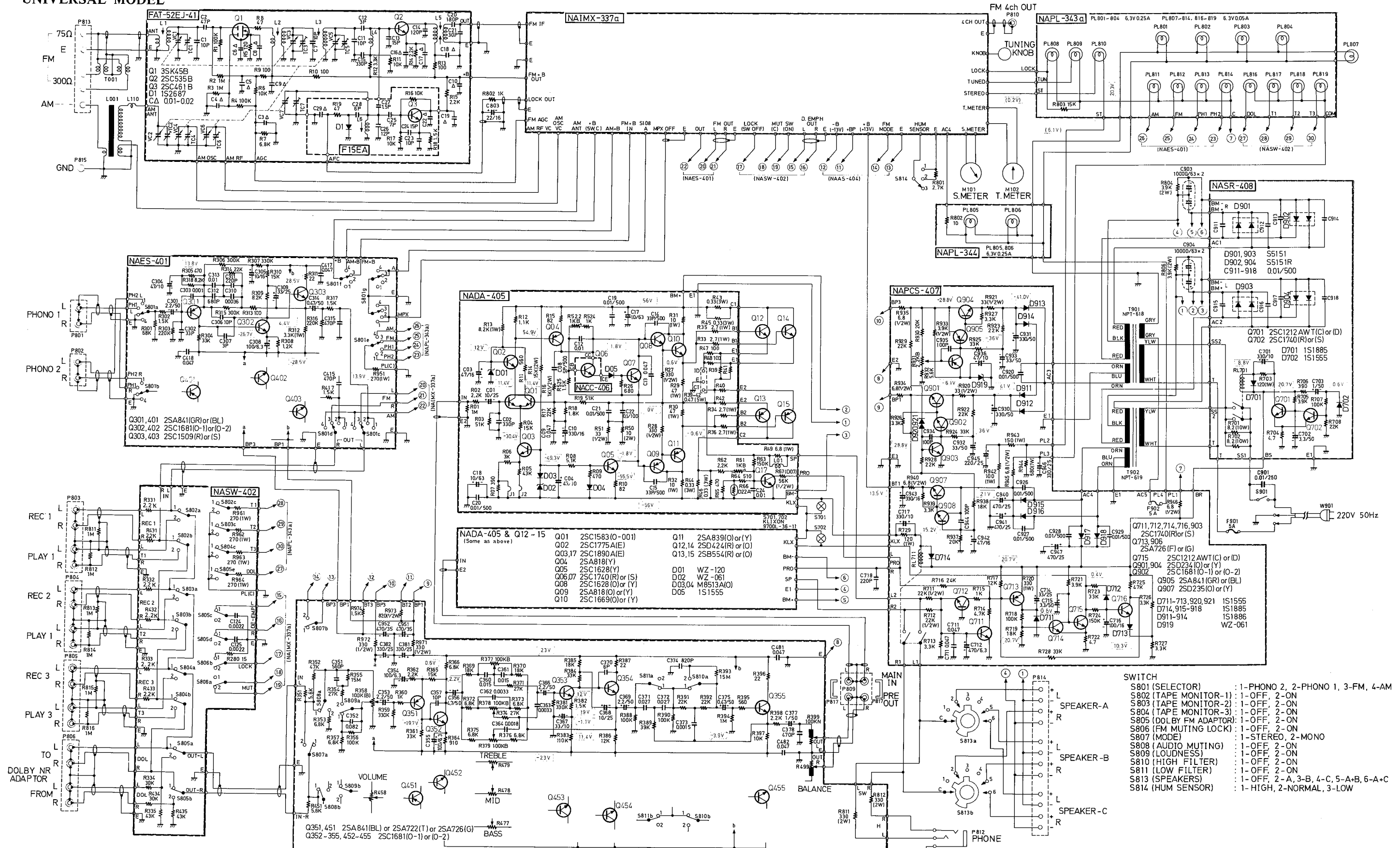

NOTE:
 • ALL RESISTORS ARE IN OHMS, 1/4WATT UNLESS OTHERWISE NOTED.
 • ALL CAPACITORS ARE IN μ F, 50W.V. UNLESS OTHERWISE NOTED.
 • ELECTROLYTIC CAPACITORS (—E—) ARE IN μ F/W.

VOLTAGE (MEASURED WITH V.T.V.M.)
 [V]: DC VOLTAGE (NO SIGNAL INPUT).
 [V]: DC VOLTAGE (FM-STEREO)

AM/FM TUNER SCHEMATIC DIAGRAM

U.S.A. MODEL

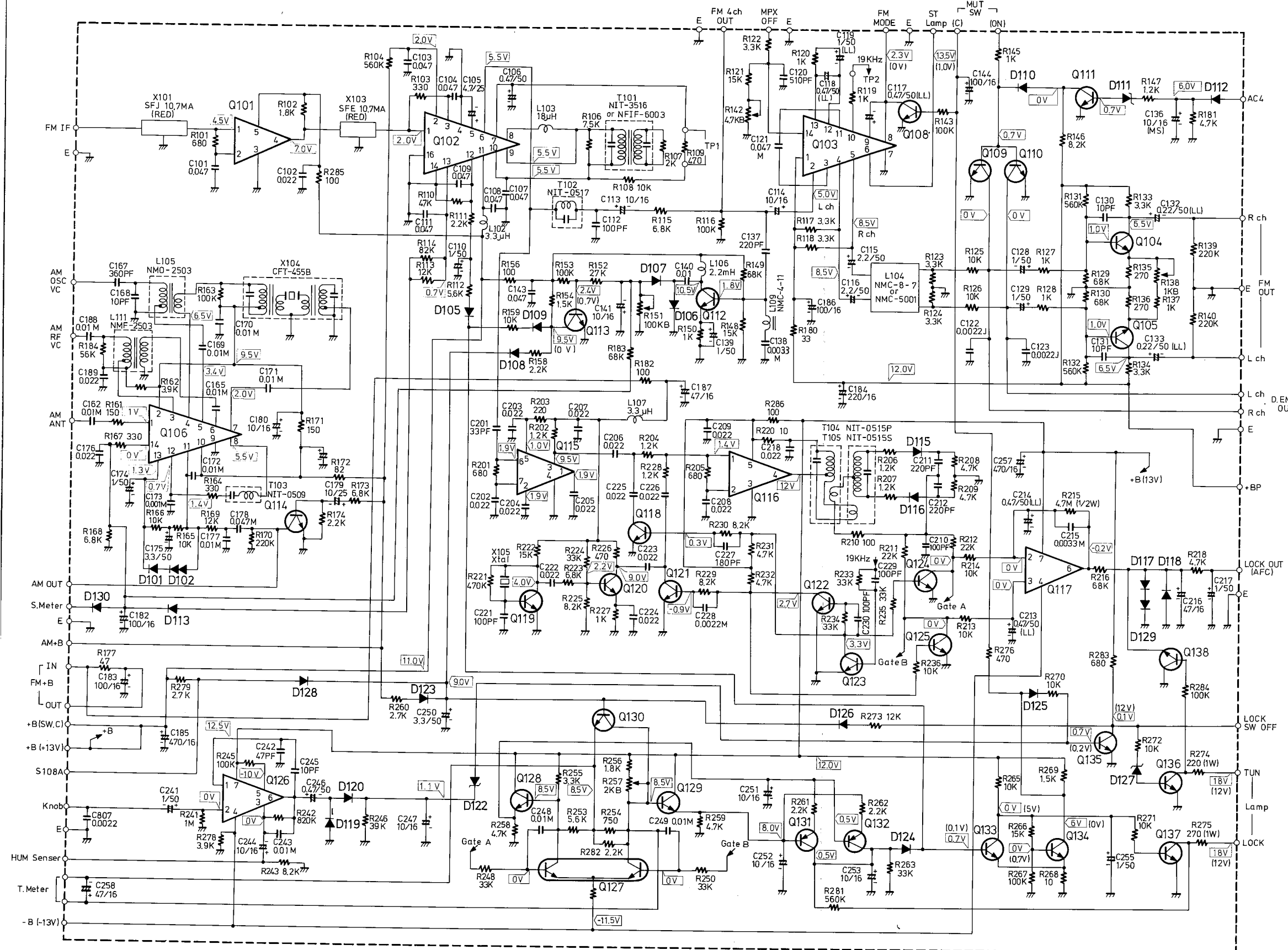

- Q101, Q116-----TA7060P
- Q102-----HA1137
- Q103-----HA1156W
- Q104, Q105-----2SC1312(F)
- Q106-----HA1151
- Q108, Q111, Q114-----2SC945(Q or 2SC732(B) or(GR))
- Q109, Q110, Q118, Q130-----2SC1317(R) or 2SC735(Y)
- Q121-Q125, Q133-Q138-----
- Q112, Q113, Q128, Q129-----2SC733(BL)
- Q115-----TA7061AP
- Q117-----TA7504S
- Q119, Q120-----2SC380(O)
- Q126-----TA7136P
- Q127-----2SC1583G
- Q131, Q132-----2SA726(F)

- D101, D105, D110, D118-----1S1555
- D124, D125, D128-----VD1212
- D102-----VD1212
- D106-D109, D112-D117-----
- D119, D120, D123, D126-----1N60
- D129, D130-----
- D111-----WZ051 or RD5.1EB
- D12-----YZ047 or RD4.7EB
- D127-----WZ061 or RD5.6EC

NOTES

- ALL RESISTORS ARE IN OHMS, 1/4 WATT UNLESS OTHERWISE NOTED.
- ALL CAPACITORS ARE IN μ F, 500WV UNLESS OTHERWISE NOTED.
- ELECTROLYTIC CAPACITORS (-H-) ARE IN μ F/WV.
- VOLTAGE (MEASURED WITH V.T.V.M.)
- (V) DC VOLTAGE (NO INPUT SIGNAL).
- () DC VOLTAGE (FM STEREO).

SCHEMATIC DIAGRAM

U.S.A. MODEL

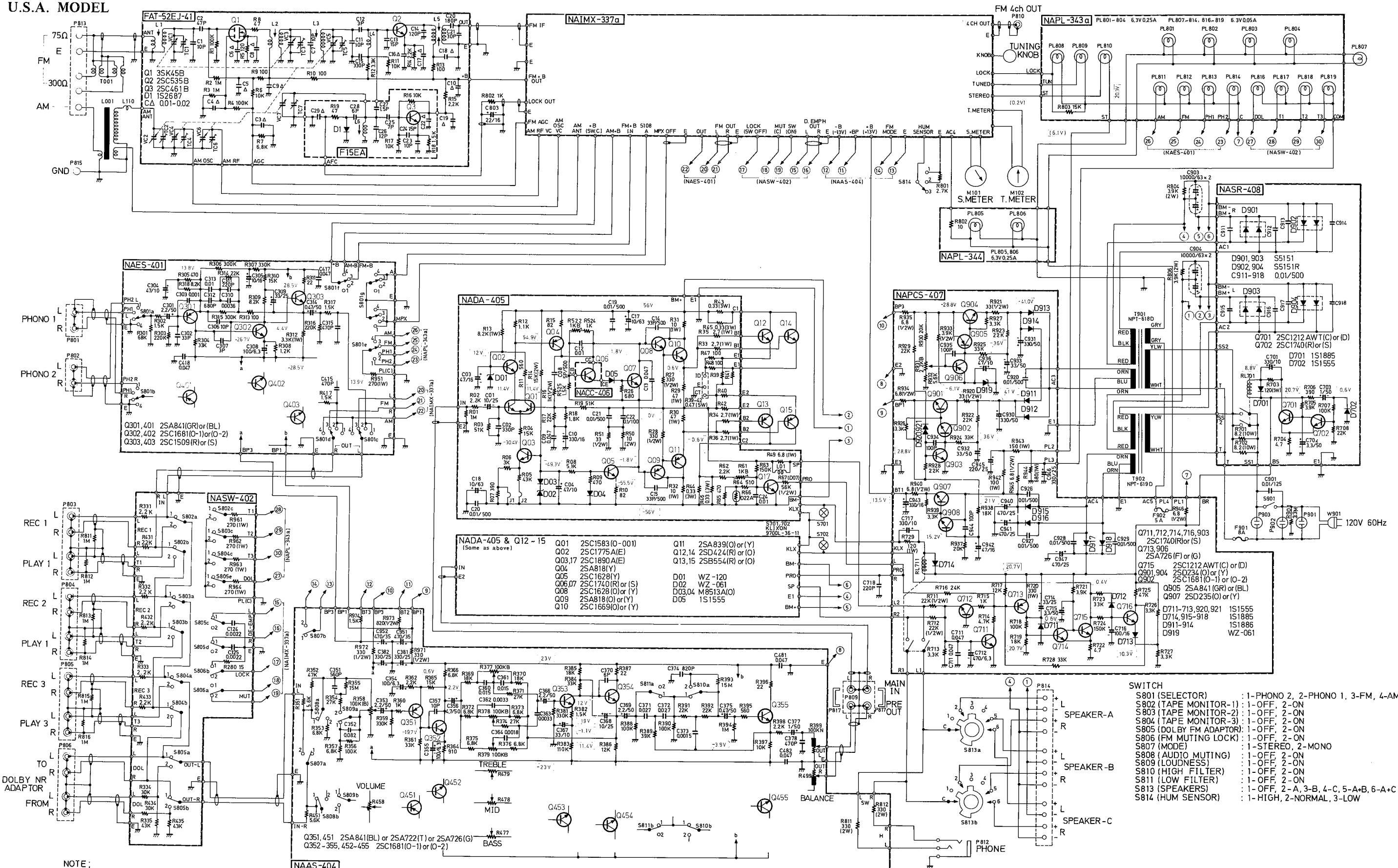

- SWITCH**
- S801 (SELECTOR) : 1-PHONO 2, 2-PHONO 1, 3-FM, 4-AM
 - S802 (TAPE MONITOR-1) : 1-OFF, 2-ON
 - S803 (TAPE MONITOR-2) : 1-OFF, 2-ON
 - S804 (TAPE MONITOR-3) : 1-OFF, 2-ON
 - S805 (DOLBY FM ADAPTOR) : 1-OFF, 2-ON
 - S806 (FM MUTING LOCK) : 1-OFF, 2-ON
 - S807 (MODE) : 1-STEREO, 2-MONO
 - S808 (AUDIO MUTING) : 1-OFF, 2-ON
 - S809 (LOUDNESS) : 1-OFF, 2-ON
 - S810 (HIGH FILTER) : 1-OFF, 2-ON
 - S811 (LOW FILTER) : 1-OFF, 2-ON
 - S813 (SPEAKERS) : 1-OFF, 2-A, 3-B, 4-C, 5-A+B, 6-A+C
 - S814 (HUM SENSOR) : 1-HIGH, 2-NORMAL, 3-LOW

NOTE:

- ALL RESISTORS ARE IN OHMS, 1/4WATT UNLESS OTHERWISE NOTED.
- ALL CAPACITORS ARE IN μ F, 50W.V. UNLESS OTHERWISE NOTED.
- ELECTROLYTIC CAPACITORS ARE IN μ F/W.V.

VOLTAGE (MEASURED WITH V.T.V.M.)

- v: DC VOLTAGE (NO SIGNAL INPUT)
- v: DC VOLTAGE (FM-STEREO)

PACKING PROCEDURES

U.S.A. MODEL

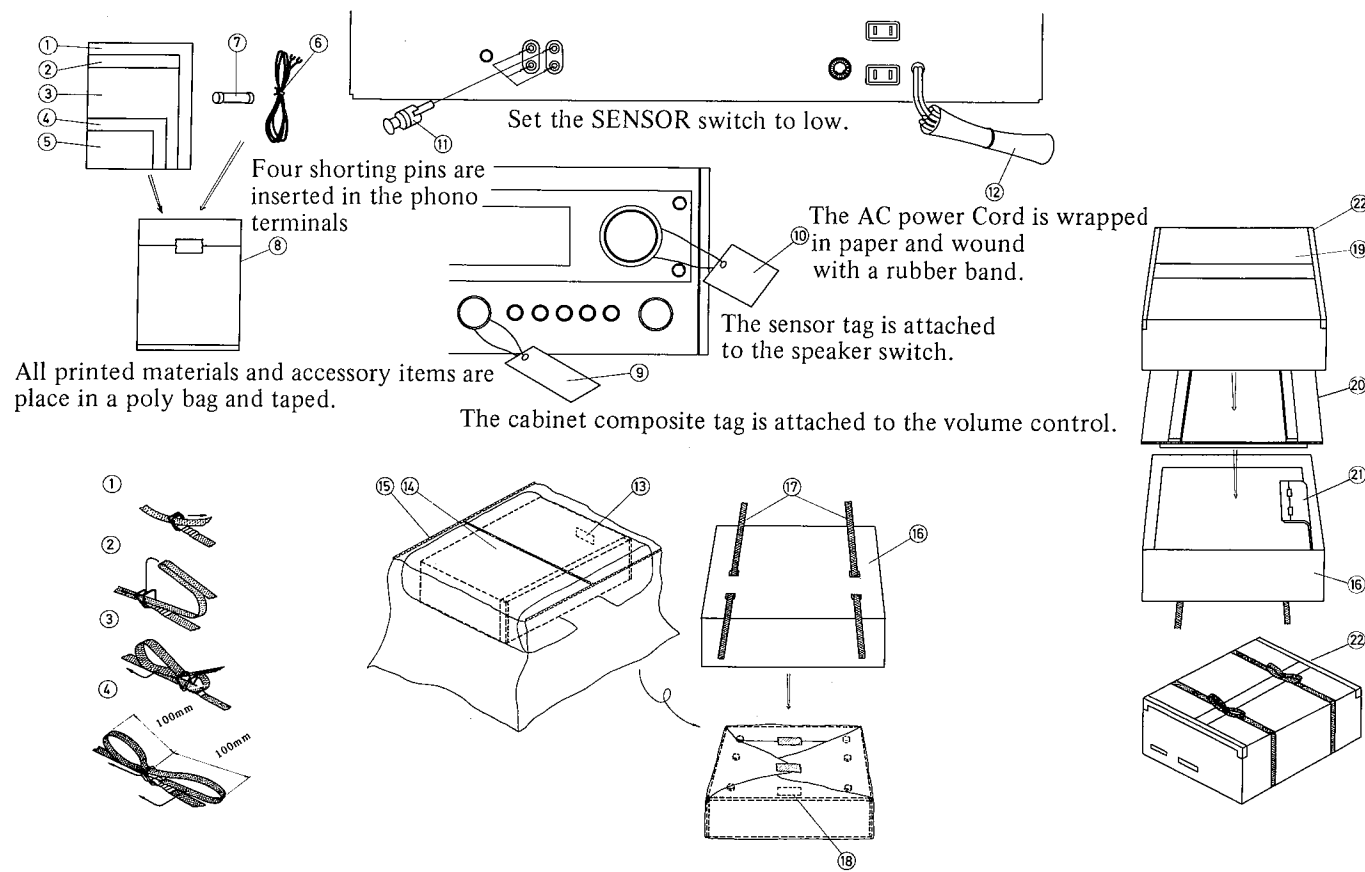

UNIVERSAL MODEL

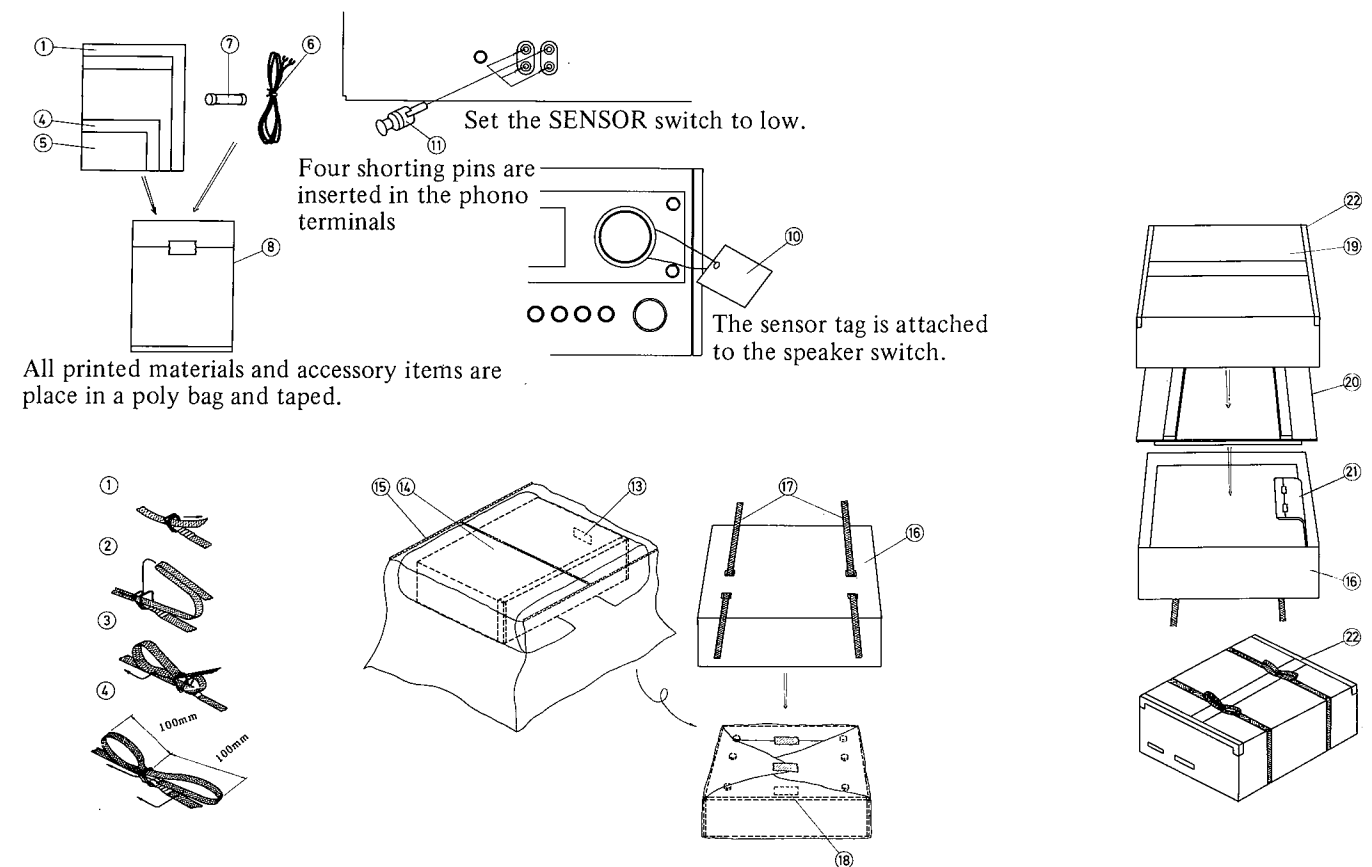

PARTS LIST

REF. NO.	PARTS NO.	DESCRIPTION	REF. NO.	PARTS NO.	DESCRIPTION
1	29340205	Instruction Manual	13	282969	Caution Card A
2	29358001	Service Station List	14	29095003	670x1600mm Sheet
3	29355046	Caution Card for Warranty Card	15	29100029	Poly Bag
4	29365003	Warranty Card	16	29090223	Pad, Bottom
5	292017-2	Silicon Cloth	17	29112001	Band
6	292064	5059-01 FM Antenna	18	293041	Caution Card
7	252053	8A(ST-6) Fuse	19	29050138	Carton Box
8	29100006A	Poly Bag	20	29090224	Pad, Top
9	29380004	Cabinet Composite Tag	21	13759119	Accessory Bag Complete
10	29355045	Sensor Tag	22	260012	Adhesive Tape
11	250153	PO-107 Shorting Pin			
12	290076	AC Cord Wrapper			

PARTS LIST

REF. NO.	PARTS NO.	DESCRIPTION	REF. NO.	PARTS NO.	DESCRIPTION
1	29340207	Instruction Manual	14	29095003	670x1600mm Sheet
4	29365001-1	Warranty Card (Only German Model)	15	29100029	Poly Bag
5	292017-2	Silicon Cloth	16	29090223	Pad, Bottom
6	29064	5059-01 FM Antenna	17	29112001	Band
7	252020	5A-T Fuse	18	293041	Caution Card
8	29100006A	Poly Bag	19	29050138	Carton Box
10	29355045	Sensor Tag	20	29090224	Pad, Top
11	250153	PO-107 Shorting Pin	21		Accessory Bag Complete
12	290076	AC Cord Wrapper	22	260012	Adhesive Tape
13	282969	Caution Card A	23	253088	AS-VDE-1 (German Model)
				253086	AS-CEE-1 (Universal Model)

■ **ONKYO U.S.A. CORPORATION**
FASTERN OFFICE
 42-07 20th Avenue Long Island City N.Y. 11105 U.S.A. PHONE:

■ **ONKYO U.S.A. CORPORATION**
MIDWEST OFFICE
 935 Sivert Drive, Wood Dale, Ill. 60191 U.S.A. PHONE: Chicago 312(595) 2970

■ **INTERNATIONAL DIVISION**
 The 24th MORI Bldg., 23-5, Nishishinbashi 3-chome, Minato-ku, Tokyo, Japan PHONE: TOKYO(432)6981
 TELEX: 242-3551

■ **ONKYO Deutschland G.M.B.H ELECTRONICS**
 8034 München-Germering Industriestrasse 18 West Germany PHONE: München 089-845041 TELEX: 05-21726

■ **ONKYO Handels - B.m.b.H**
 A-5011 Salzburg, Criesgasse 4/11, Austria PHONE: Salzburg 6222-43462 TELEX: 63539