

ONKYO® SERVICE MANUAL

QUARTZ LOCKED STEREO RECEIVER MODEL TX-8500 MKII

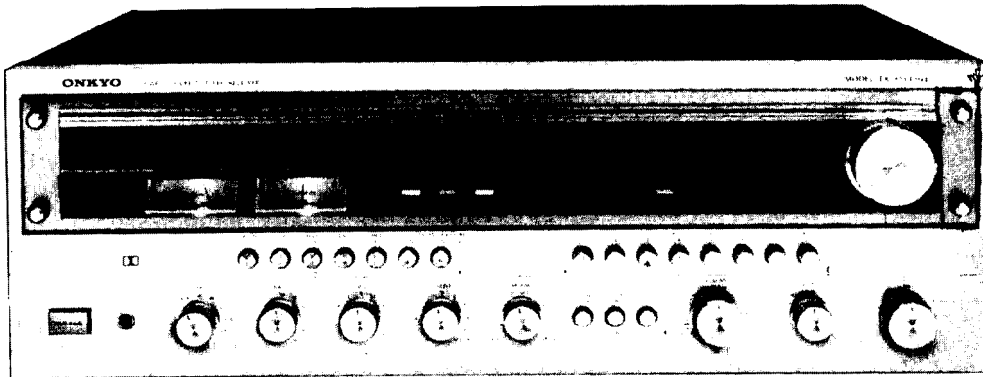

TABLE OF CONTENTS

Item	Page
Specifications	2
Precautions	3
Service procedures	3
Stringing diagram	4
Exploded view	5
Component location	6
Circuit description	8
Alignment procedures	11
Block diagram	14
Tuner section-schematic diagram	17
PC board view and parts list	19
Schematic diagram	27
Power amplifier adjustment	29
Packing procedures	30

ONKYO®
AUDIO COMPONENTS

SPECIFICATIONS

Amplifier section		Spurious Rejection: FM: 1/2 IF: 100dB
Power Output:	160 watts per channel, min. RMS, at 8 ohms, both channels driven, from 20Hz to 20kHz, with no more than 0.05% total harmonic distortion.	Signal to Noise Ratio: FM mono: 70dB FM stereo: 65dB AM: 45dB
Total Harmonic Distortion:	0.05% at Rated power	ACA: FM: 70dB
IM Distortion:	0.05% at Rated power	AM suppression Ratio: FM: 55dB
Damping Factor:	50 (8 ohms, 1kHz)	Harmonic Distortion: FM mono: 0.15% FM stereo: 0.25% AM: 0.5%
Frequency Response:	3-30,000Hz (±1dB through TAPE) DC-60,000Hz (±1dB at power amplifier)	Frequency Response: FM: 30~15,000Hz ±1.5dB
Tilt:	better than 5% at 50Hz (through TAPE)	Stereo Separation: FM: 40dB at 1kHz 35dB 70~10,000Hz
Sensitivity and Impedance:	PHONO: 2.5mV 50 kohms EPS IN: 150mV 50 kohms EPS OUT: 150mV 3.5 kohms (PHONO) TAPE PLAY: 150mV 50 kohms TAPE REC: 150mV 3.5 kohms (PHONO) PRE OUT: 1V 3 kohms MAIN IN: 1V 50 kohms	Muting Level: FM: 17.2dBf, 4μV Stereo Threshold: FM: 17.2dBf, 4μV Quartz Lock Level: FM: 17.2dBf, 4μV Sub Carrier Suppression: FM: 60dB
Phono Overload:	250mV RMS at 1kHz, 0.05% THD.	General
Tone Controller:	TREBLE: ±10dB at 10kHz (Turn over at 2kHz) MID: ±5dB at 1kHz BASS: ±12dB at 100Hz (Turn over at 400Hz)	Power Supply Rating: AC 120V 60Hz Controls: POWER SPEAKERS (OFF, A, B, C, A+B, A+C) SELECTOR (AM, FM, DOLBY FM, PHONO 1, PHONO 2) TAPE MONITOR (DUB 1→2, TAPE 1, SOURCE, TAPE 2, DUB 2→1) TUNING, VOLUME, BALANCE, TREBLE, MID, BASS FM MUTING, EPS, LOUDNESS, MODE FILTER HIGH, LOW & SUBSONIC, AUDIO MUTING BASS & TREBLE TURNOVER PRE SET (1-7, MANUAL/LOCK) SENSOR (rear panel)
Signal to Noise Ratio:	PHONO: 70dB (IHF C) 88dB (IHF A 10mV input) TAPE, EPS: 90dB (IHF C) 95dB (IHF A)	Antennas: FM: 300 ohms balanced and 75 ohms unbalanced AM: built-in ferrite core antenna and external terminal
RIAA Curve Deviation:	±0.2dB, 30Hz to 15kHz	Outputs: SPEAKER A, B & C, HEAD- PHONES TAPE REC OUT 1 & 2, EPS OUT PRE OUT FM 4CH OUT AC OUTLET (SWITCHED & UNSWITCHED x 2)
Filter:	HIGH: 6kHz (12dB/oct.) LOW: 100Hz (12dB/oct.) SUBSONIC: 7Hz (6dB/oct.)	Inputs: PHONO 1 & 2, TAPE PLAY 1 & 2, EPS IN MAIN IN, FM & AM ANTENNA
Loudness:	+5,5dB at 40Hz +5dB at 20kHz	Dimensions: 538 W x 187 H x 475 D mm 21 3/16" x 7 3/8" x 18 11/16"
Audio Muting:	-20dB	Weight: 28kg. 61.6 lbs.
Tuner section		Semiconductors: 9 FETs, 93 Transistors, 12 ICs, 66 Diodes, 1 Fluorescent digital display tube
Tuning Range:	FM: 88~108MHz AM: 530~1605kHz	
Usable Sensitivity:	FM mono: 9.3dBf, 1.6μV FM stereo: 17.2dBf, 4μV AM: 25μV	
50dB Quieting Sensitivity:	FM mono: 14.7dBf, 3μV FM stereo: 36dBf, 35μV	
Intermediate Frequency:	FM: 10.7MHz AM: 455kHz	
Capture Ratio:	FM: 1.3dB	
Image Rejection Ratio:	FM: 100dB AM: 60dB	
IF Rejection Ratio:	FM: 100dB AM: 55dB	

Specifications and features are subject to change without notice.

PRECAUTIONS

1. For continued protection against fire hazard, replace only with same type and same rating fuse.

		PARTS NO.
AC fuse	5A (ST-6)	252050
Lamp fuse	4A-T	252014

2. Replacement for power, complementary and driver transistors, if necessary, must be made from the same beta (h_{FE}) group as the original type.
3. Always disconnect the chassis from power line when soldering.
Turning the power switch OFF is not enough.
Power line leakage passing through the heating element may destroy the transistors.
4. All CMOS devices have diode input protection against adverse electrical environments such as static discharge. Unfortunately, there can be severe electrical environments during the process of handling. For example, static voltages generated by a person walking across a common waxed floor have been measured in the 4 to 15kV range (depending on humidity, surface conditions, etc.) These static voltages are potentially disastrous when discharged into a CMOS input considering the energy stored in the capacity ($\approx 300\text{pF}$) of the human body at these voltage levels.
Present CMOS gate protection structures can generally protect against overvoltages. This is usually sufficient except in the severe cases. Following are some suggested handling procedures for CMOS devices, many of which apply to most semiconductor devices.
 1. All MOS devices should be stored or transported in materials that are somewhat conductive. MOS devices must not be inserted into conventional plastic "snow" or plastic trays.
 2. All MOS devices should be placed on a grounded bench surface and operators should ground themselves prior to handling devices, since a worker can be statically charged with respect to the bench surface.
 3. Nylon clothing should not be worn while handling MOS circuits.
 4. When lead straightening or hand soldering is necessary, provide ground straps for the apparatus used.
 5. Double check test equipment setup for proper polarity of voltage before conducting parametric or functional testing.
 6. All unused device inputs should be connected to V_{DD} or V_{SS} .

SERVICE PROCEDURES

1. REMOVAL OF THE DIAL GLASS

Remove four screws holding dial glass and front panel.

NOTES: The dial glass has been mounted by applying an 800gr torque to the screws. If the dial glass is removed during repairs, and a torque driver is available, apply 800gr torque to the screws when replacing. If however, a torque driver is not available, simply tighten the screws by hand. When replacing the dial glass, insert all relevant component parts in accordance with the cross sectional diagram.

2. REMOVAL OF THE FRONT PANEL

- 1) Remove six screws holding the top cover and side bracket.
- 2) Loosen the enamel screw on the tuning shaft.
- 3) Remove the Speakers, Bass, Middle, Treble, Tuning, Balance, Tape monitor, Source selector and Volume knobs.
- 4) Remove five screws holding the front panel and front bracket.

3. REMOVAL OF THE BOTTOM BOARD

- 1) Remove six tapping screws holding the leg and bottom board.
- 2) Remove six screws holding the bottom board and side bracket.
- 3) Remove a wooden screw (M3.1+20F) holding the bottom board and spacer.

4. CHECKING TUNER PC BOARD

- 1) Remove the top cover and bottom board.
- 2) Remove four screws holding the rectifier p.c.b. bracket and chassis.

5. CHECKING POWER AMPLI. PC BOARD (NACR-516, NACC-517 and Power ampli. transistor)

- 1) Remove the top cover.
- 2) Remove two screws holding the radiator bracket and chassis.
- 3) Send the radiator down in the direction of the side bracket.
- 4) Remove eight screws holding the radiator and power ampli. p.c.b. bracket.

6. SENSOR SWITCH

For matching the automatic FM tuning quartz lock system to the various operating conditions. Set to LOW initially and switch to NORMAL or HIGH if the TUNED lamp does not turn off as soon as the tuning knob is touched.

7. REPLACING METER

- 1) Remove the top cover and front panel.
- 2) Remove two screws securing the illumination bracket and front bracket.
- 3) Remove the pointer from the front bracket.
- 4) Remove two screws securing the lamp case (L) and front bracket.
- 5) Remove two screws securing the lamp case (R) and front bracket.
- 6) Then remove the dial plate from the drive shaft.
- 7) Remove two screws securing the back plate and front bracket.
- 8) The top and bottom sides of the meter covers are fastened to the back plate by adhesive tape. Remove this tape, taking care not to jar or knock the meters.

8. REPLACING PRE-SET PC BOARD

- 1) Remove the top cover and front panel.
- 2) Remove two screws securing the shielded case for equalizer p.c.b. and the chassis.
- 3) Pull out the control knobs.
- 4) Remove two screws securing the its p.c.b. and the front bracket.
- 5) When replace the pre-set switch, replace the p.c.b. complete.

STRINGING DIAGRAM

1. Open the variable capacitor complete and tie the dial cord to the spring of the drum.
2. Thread the dial cord in the direction of arrow from (1) to (2) and wind the dial cord three turns around the tuning shaft counter-clockwise.
3. Thread the dial cord to the dial pulley 2.
4. Wind the dial cord 1½ turns around the dial drum.
5. Thread the dial cord to the dial pulley 3.

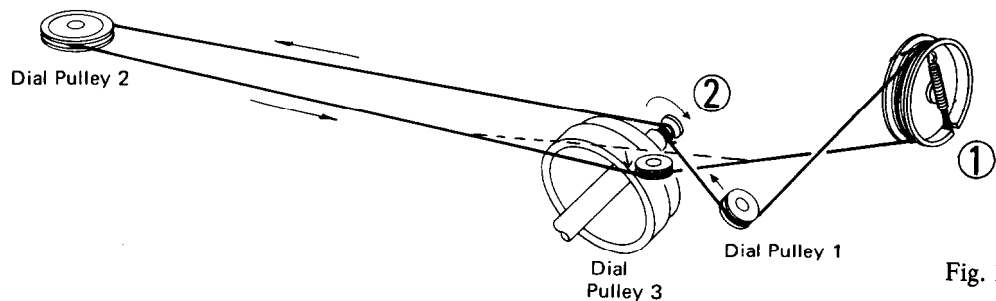
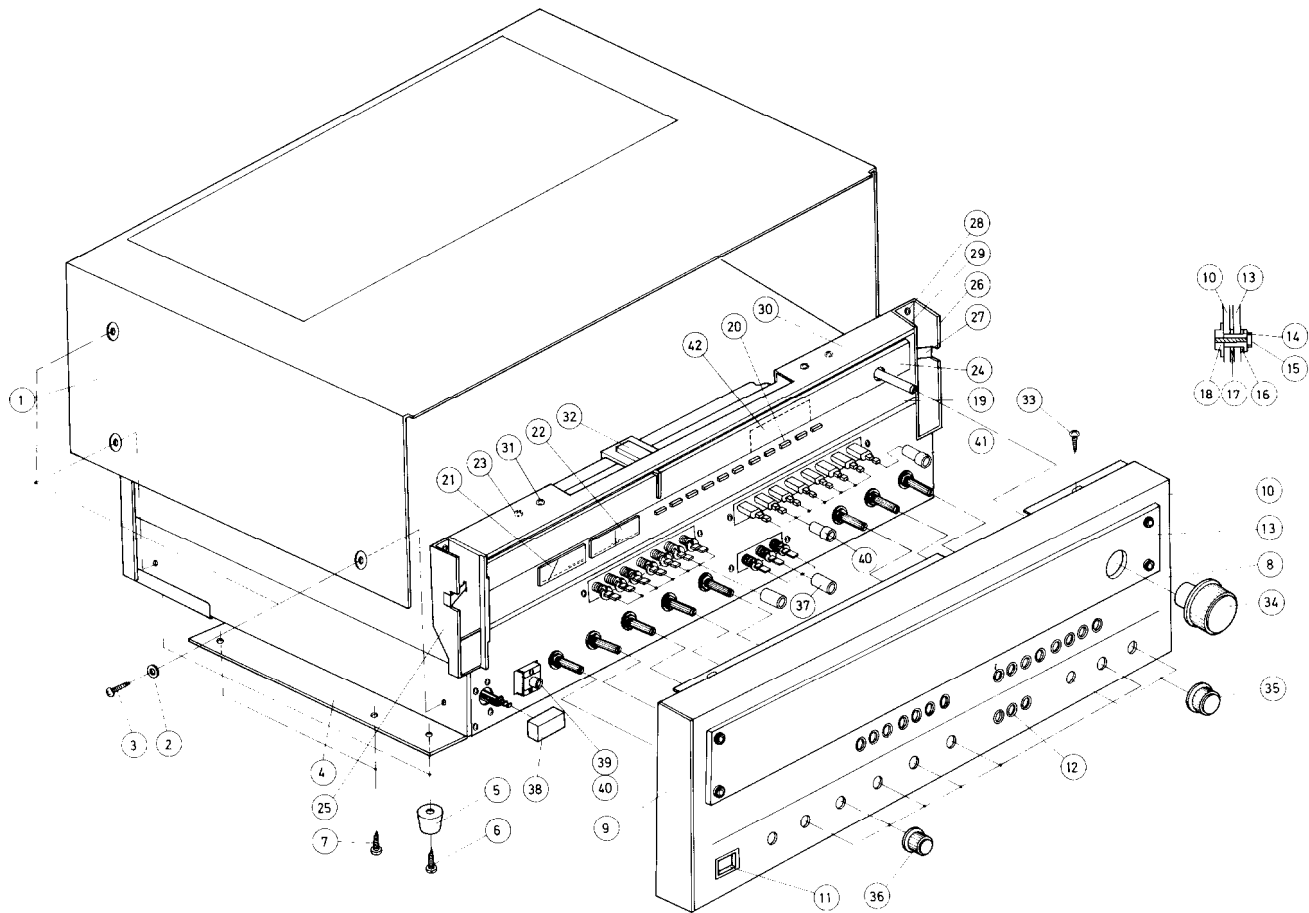

Fig. 1

EXPLODED VIEW



EXPLODED VIEW - PARTS LIST

REF. NO.	PARTS NO.	DESCRIPTION	REF. NO.	PARTS NO.	DESCRIPTION
1	28110143	Top cover	22	243087	NIND-0250S87,
2	87644012	W4X12F, Washer			Center tuning meter
3	838440109	4TTB+10C (BC)	23	834130062	3STS+6BQ
4	27170046A	Bottom board	24	28130069	Dial plate
5	280889	Leg	25	27215031A	Lamp case (L)
6	831130162	3STW+16BQ	26	27215030A	Lamp case (R)
7	831130082	3STW+8BQ	27	27140203	Spring
8	13689121-1	Front panel ass'y	28	831130082	3STW+8BQ
9	28125051A	End cap (L)	29	13719574	NAPL-474, Dial illumination p.c.b.
10	28125050A	End cap (R)	30	27240016A	Illumination bracket
11	27267027	Power switch guide	31	834130062	3STW+6BQ
12	27267026	Push switch guide	32	13689712	Pointer ass'y
13	28191027	Dial glass	33	834130062	3STS+6BQ
14	27270014	Spacer	34	28320241A	Tuning knob
15	27300038A	Screw	35	28320238	Volume knob
16	870051	Washer	36	28320237	Tone knob
17	870052	Washer	37	28320239	Push switch knob
18	86213010	WN3X10FN	38	28320235	Power switch knob
19	28133011	Back plate	39	25045018	Headphone jack
20	28198512-1	Facet	40	28320248	Knob (P)
21	243086	NIND-0500S86, Signal strength meter	41	28320249	Knob (S)
			42	28191029	Smoking plate

COMPONENT LOCATION

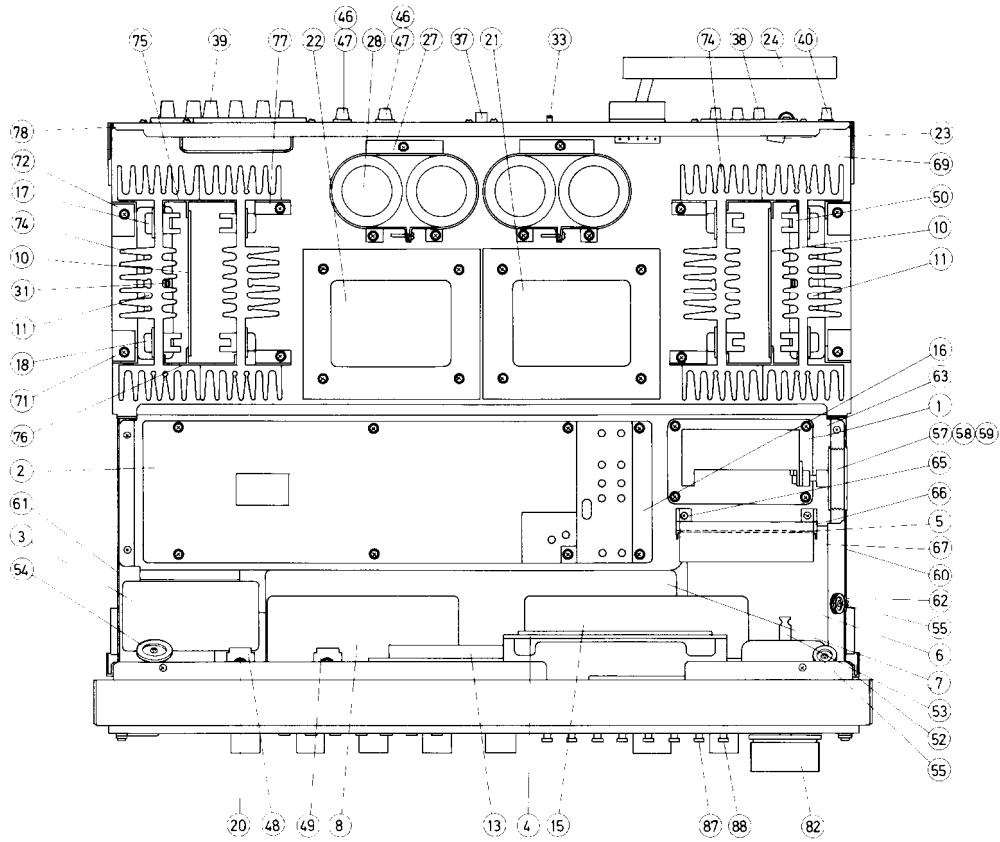

TOP VIEW

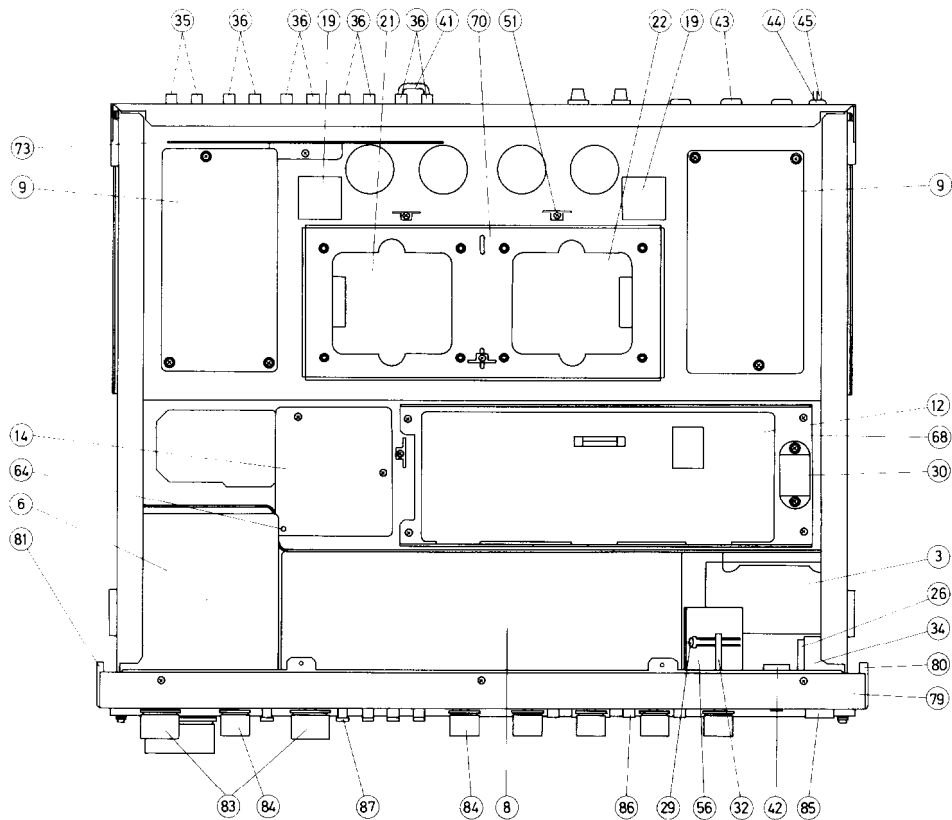

BOTTOM VIEW

COMPONENT LOCATION - PARTS LIST

REF. NO.	CIRCUIT NO.	PARTS NO.	DESCRIPTION	REF. NO.	CIRCUIT NO.	PARTS NO.	DESCRIPTION
1	U1	13689508	NAVC-508, Variable capacitor p.c.b.	41	P815	25055015	Shorted plug
2	U2	13689509	NAIRM-509, FM IF/MPX and AM p.c.b.	42	P816	25045018	LJ-100-H, Stereo headphone jack
3	U3	13689576A	NAXL-476a, Quartz locked circuit p.c.b.	43	P901-P903	25050032	S-1644-01, AC socket
4	U4	13689510	NADIS-510, Display p.c.b.	44	W901	253100	AS-UC-4, Power supply cord
5	U5	13689511	NAEQ-511, Equalizer ampli. p.c.b.	45	W901a	270280	SR-4K-4, Strainrelief
6	U6	13689512	NASW-512, Switch p.c.b.	46	F901,F902	252050	5A (ST-6), Fuse
7	U7	13689513	NAAF-513, Preamp. p.c.b.	47	F901a, F902a	250080	S-N1301, Fuseholder
8	U8	13689514	NASW-514, Switch p.c.b.	48	M801	243086	NIND-0500S86, Signal strength meter
9	U9, U12	13689557	NADA-557, Power ampli. p.c.b.	49	M802	243087	NIND-0250S87, Tuning meter
10	U10, U13	13689516	NACR-516, Power ampli. p.c.b.	50	Q513a-Q516a	250249	M-1614, Transistor socket
11	U11, U14	13689517	NACC-517, Thermo ampli. p.c.b.		Q611a-Q614a		
12	U15	13689518	NAPS-518, Power supply p.c.b.	51		250130	T-4461, Ground terminal
13	U17	13689520	NAPL-520, Indicator lamp p.c.b.	52	A001	27110063A	Front bracket
14	U20	13689521	NADN-521, FM dolby p.c.b.	53	A008	27205012	Drive shaft <i>7.30</i>
15	U21	25065050	PS-M7MA, Presetter p.c.b. <i>70⁰²</i>	54	A011	27185001	DP-26N, Dial pulley
16	U22	13689541	NAR-541, Front end p.c.b.	55	A012	27185002	DP-16N, Dial pulley
17	Q513,Q514 Q613,Q614	2200892 or 2200893	2SD665 (R) or 2SD665 (O) transistor	56	A042	27150086	Shielded plate (S)
18	Q515,Q516 Q615,Q616	2200882 or 2200883	2SB645 (R) or 2SB645 (O) transistor	57	A051	27200019	Dial drum
19	D901,D902	223852	S5188, Silicon diode	58	A052	273803	SP-14A, Dial drum spring
20	PL802, PL803	210041	PL8V0.15AW-2, Meter lamp	59		13689701	Stringing
21	T901	230253	NPT-647D, Power transformer	60	A057	27115036	Side bracket (R)
22	T902	230254	NPT-648D, Power transformer	61	A056	27115035	Side bracket (L)
23	T001	233026	NBLN-1, Balun transformer	62	A058	27140213	Bracket for dial pulley
24	L001	232075	NMA-3017, AM bar antenna	63	A063	27100033A	Sub chassis
25	L002	233105 or 233024	NCH-1005 or NCCH-1501	64	A067	27190009	Holder
26	C901	3504012	UL125V103M, UL capacitor	65	A068	27140224	Bracket (C)
27		27300128	Band for capacitor	66	A069	27140225	Bracket (D)
28	C911-C914	3504110	15,000 μ F, 78V, Elect. capacitor	67	A070	27225030	Shielded cover
29	R801,R802	441723914	390 Ω , 2W, Metal oxide film resistor	68	A073	27130133	Bracket
30	RL901	25065049	NRL-2P10A-DC12-01, Relay	69	A078	27100032A	Chassis
31	S701,S702	252041	9700L-36-11, Klixson	70	A080	27130134	Bracket for power transformer
32	S805	25030077	NRS-266-30YW, Speaker selector switch	71	A087	27140221	Bracket (E)
33	S806	25065016	NSS-2327, Sensor switch	72	A088	27140222	Bracket (F)
34	S901	25035015	NPS-111LA3, Power switch	73	A093	27150087	Shielded plate
35	P801	25045044	NPJ-4PRBL21, Phono input terminal	74	A097	27160042	Radiator
36	P802-P805	25045025	NPJ-4PRBL03, Tape/EPS/Pre out/Main input terminal	75	A098	27140219	Bracket (A)
37	P806	250256A	NTM-1WPBL-E1, 4ch. output terminal	76	A099	27140220	Bracket (B)
38	P809	25060021B	NTM-3PUN1, Antenna terminal	77	A100	27140223	Bracket (G)
39	P810-P812	25060029	NTM-4PRMN05, Speaker terminal	78	A110	27120125	Back panel
40	P813	25060008	Ground terminal	79		27210101	Front panel
				80	A503	28125051A	End cap (L)
				81	A502	28125050A	End cap (R)
				82	A801	28320241	Tuning knob
				83	A802	28320238	Volume control knob
				84	A803	28320237	Tone control knob
				85	A804	28320235	Power knob
				86	A805	28320239	Push switch knob
				87	A806	28320248	Knob (P)
				88	A807	28320249	Knob (S)

27300071 SHAFT SUPPORT BEARING

CIRCUIT DESCRIPTION

1. SPEAKER PROTECTION CIRCUIT

The speaker protection circuit is operated:

- 1) When the B circuit is unstable when the power is turned ON (approximately 5 seconds).
- 2) When the speaker terminals are shorted and abnormal current has flowed in the power amplifier thru this low impedance.
- 3) When the center voltage has increased because of trouble at the differential amplifier, etc.
- 4) When the temperature of the heat sink has risen.

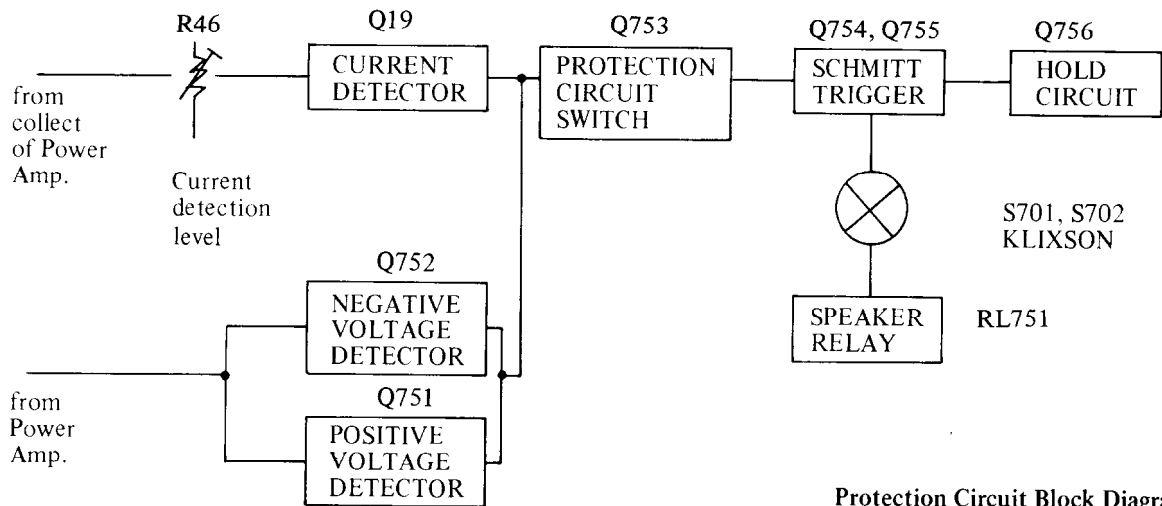

Protection Circuit Block Diagram

When **Q753** is turned on by voltage detection or current detection, **Q754** is turned ON by the voltage drop across **R757**. **Q754, Q755** constitute a digitalized, fast response Schmitt trigger circuit. When **Q754** is turned ON, **Q755** is turned OFF. **Q755** is a relay drive transistor. When it is turned OFF, the relay is also turned OFF. The temperature of the heat sink is detected at the collector circuit of **Q755** by the Klixson. If the temperature of the heat sink rises excessively, the klixson is turned OFF and the relay is also turned OFF.

When the power switch is turned ON, charging current flows thru the loop **R758 → C752 → R756, R757** and **Q754** is turned ON by the voltage drop across **R757**. Consequently, **Q755** and the relay are turned OFF until the charging current drops below a certain value. When the power switch is turned OFF, the B voltage falls and **C752** is quickly discharged thru the loop **C752 → R758 → D755**. During normal operation, **C752** is charged to almost the B voltage. But since the saturation resistance of **Q753** is sufficiently low, when **Q753** is turned ON, **C752** is quickly discharged thru the loop **C752 → R758 → Q753** and the relay is also turned OFF. The relay is not turned ON again thereafter until **C752** is charged, even if the set should return to normal and **Q753** is turned OFF.

HOLD CIRCUIT

The reference voltage is produced by **R765, R764**, **Q756** is operated as a comparator. When **Q755** has been turned OFF, the collector voltage of **Q755** rises and **C753** is charged. Therefore, when **C753** is charged to above a certain voltage relative to the reference voltage at the junction of **R765** and **R764**, **Q756** is turned ON, **Q753** is turned ON thru **R766** and the circuit is held.

CURRENT DETECTOR

Q19 is turned ON by the voltage detected from the collector circuit of the power amplifier. **C24** prevents erroneous operation, **R46** sets the current detection level and thermister **R49** controls changes in the current detection level caused by temperature rise.

When the impedance is low at a certain frequency of the speaker, the protection circuit may be unexpectedly actuated each time a large audio signal of that frequency has entered. However, when this occurs the relay is opened and the power amplifier current returns to normal. The power amplifier current is also automatically returned to normal in a like manner when the load has been inadvertently shorted momentarily.

When connected with the load shorted, the relay is repeatedly turned ON and OFF in load short → relay OFF (no load) → automatic reset (load short current detection) → relay OFF order. Since the OFF time is sufficiently longer than the relay ON time in this case, the voltage across **C753** gradually increases until a voltage sufficient to turn **Q756** is reached, at which time the relay is held OFF, thus protecting the power transistor against damage by a continuous overcurrent.

VOLTAGE DETECTOR

The voltage detection circuit is an OR circuit consisting of Q751, Q752. First, the Lch and Rch signals are mixed by D751, D752, D753, D754. When this voltage is minus, Q752 is turned ON and when this voltage is plus, Q751 is turned ON and the relay is turned OFF.

Since the center voltage is unrelated to ON-OFF of the load, when an abnormal voltage has been detected, the relay remains off and the hold circuit is operated until the voltage returns to normal. Once the hold circuit has been actuated it is not reset until the power has been turned back on after the cause of the trouble has been corrected.

2. RL901 RELAY

To prevent a rush current from flowing when the power is turned ON, when AC is applied to the transformer thru R902, R903, B voltage is applied, current flows thru the loop R781 → C761 → R782 → R782, Q761 is turned ON and Q762 is turned OFF by the voltage drop across R783 and the relays is turned OFF. When the charging current drops below a certain value, Q761 is turned OFF, the relay is turned ON and the rated voltage is applied to the power transformer.

3. POWER AMPLIFIER

The power amplifier is a DC amplifier. Being a DC amplifier, even very small DC variations in the input will be amplified, and appear at the output. So the suppression of noise and drift in the low frequency range is very important indeed. Consequently, a low-noise dual gate FET differential input has been employed.

4. VOLUME CONTROL CIRCUIT

The volume control is linked to both before and after the preamplifier, considerably reducing the amount of residual noise when the control is turned right down.

5. QUARTZ LOCKED CIRCUIT

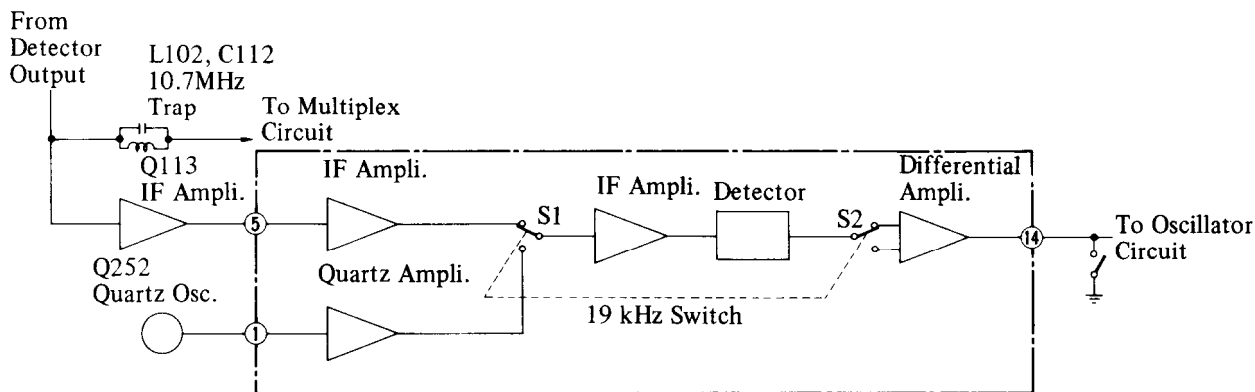

The quartz locked circuit compares the frequency difference between the 10.7MHz reference signal and the IF signal, the difference being used to subsequently drive the AFC circuit.

A 10.7MHz component is extracted from the quadrature detector output by the L102 trap, amplified by the Q113 IC, and applied to pin no. 5 of the Q251 IC. An accurate 10.7MHz reference signal is generated by the quartz oscillator, and applied to pin no. 1 of the same IC. A 19kHz square wave is obtained from pin no. 10 of the PLL IC, and applied to pin no. 3 of Q251. The IF signal and the quartz oscillator reference signal are switched back and forth in a 19kHz cycle, and passed on to the detector and amplification stages. When S1 and S2 and both connected to the IF signal line, the IF frequency is detected, resulting in the generation of a voltage whose level corresponds to the IF frequency. This voltage is then applied to one of the differential amplifier inputs. When S1 and S2 are then both switched across to the quartz oscillator signal line, the quartz oscillator reference signal is detected, converted into the corresponding voltage, and applied to the other input of the differential amplifier. The difference between the IF detector DC component and quartz oscillator detector component is then amplified, appearing at pin no. 14 of the IC. This voltage serves as the AFC circuit control voltage. Any slight drift or deviation in the detector transformer will therefore result in the same amount of drift in both lines, thereby maintaining a constant difference. Precise local oscillator frequency will thus be kept at all times.

3. TUNING METER CIRCUIT

The tuning meter circuit compares the DC component difference between the quartz oscillator signal and IF signal detector outputs, and drives the tuning meter in accordance to this difference. The Q253 transistor is designed to short circuit the tuning meter when the input signals are weak.

7. AFC SWITCHING CIRCUIT

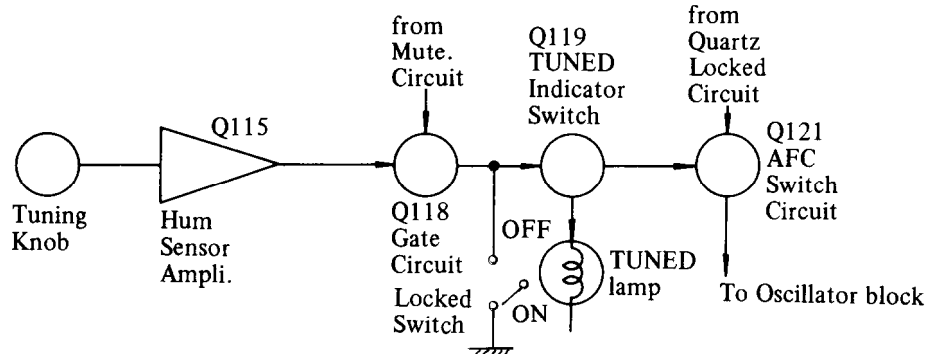

In order to ensure accurate turning, the AFC circuit is turned off automatically once the tuning knob is touched, and also when the muting circuit is switched off.

When a station is tuned, Q118 will turn off and Q119 turn on (since Q116 will already be off and Q117 on), resulting in the LOCKED lamp turning on. And since Q121 will turn off when Q119 turns on, the AFC circuit will also begin to operate.

When the tuning knob is touched, a certain amount of hum is induced. This hum is amplified by Q115, rectified (full-wave) by D115 and D116 into a DC signal, and applied to Q118 is consequently turned on, resulting in the AFC circuit being switched off. If, however, the hum level is rather low, the LOCKED lamp might not turn on even when the tuning knob is touched. If this happens, reset the rear panel sensor switch to either the Normal or High positions.

8. MUTING CIRCUIT

The muting circuit is activated by the combined effects of the IF component and noise component. The IF level detector circuit is incorporated in the quadrature IC, the output appearing at pin no. 12. This pin is switched to high level when the IF level drops below the muting level, but is switched back to low level when the IF level exceeds the muting level again. The detection of noise above 100kHz in the composite signal will also result in the noise detector output being switched to high level.

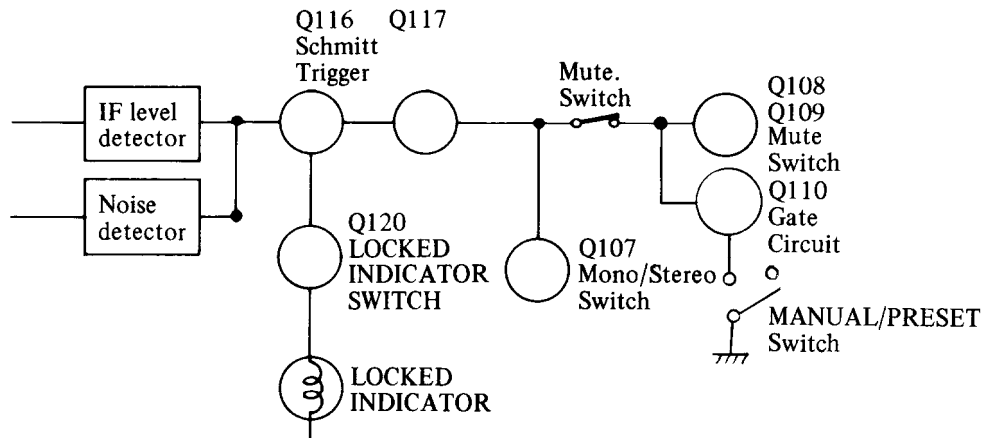

Consequently, when two detector circuit outputs are switched to low level, the Q116 transistor is cut off, and the Q120 transistor turned on, followed by the LOCKED lamp turning on. At the same time, Q117 is also turned on, and Q107 turned off, resulting in the STEREO lamp turning on (if the tuned station is broadcasting in stereo). Q108 and Q109 are also turned off, resulting in the appearance of an FM broadcast output signal at the receiver's output terminals.

The muting circuit is activated when press the MANUAL or PRE-SET switch.

ALIGNMENT PROCEDURES

INSTRUMENTS REQUIRED

1. DC Voltmeter
2. AM Sweep Generator
3. AM/FM Signal Generator
4. AC VTVM
5. Oscilloscope
6. Monitorscope
7. Distortion Analyzer
8. Stereo Modulator
9. Frequency Counter
10. DC Voltmeter (High Impedance)
11. AC VTVM (Max. Frequency: More than 120MHz)

GENERAL ALIGNMENT CONDITIONS

1. Signal input should be kept as low as possible.
2. Standard modulation is 400Hz 30% (AM), 1kHz 100% (FM MONO), pilot 9% sub and main 91% (FM STEREO).
3. Standard knob position
 SPEAKERS A
 MID, BASS, TREBLE, BALANCE Center
 HIGH/LOW/SUBSONIC FILTER OFF
 MODE STEREO
 EPS OFF
 LOUDNESS, AUDIO, MUTE OFF
 MUTING LOCK OFF
 TAPE 1, 2 OFF (SOURCE)
 PRESET MANUAL ON
 LOCK OFF

AM IF ALIGNMENT

1. Set SELECTOR switch to AM.
2. Set radio dial to quiet point.

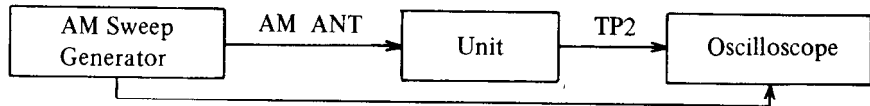

Set signal	Adjust	Oscilloscope	Remarks
455kHz	X103	Maximum Symmetrical Response	Usually not necessary to adjust

AM RF ALIGNMENT

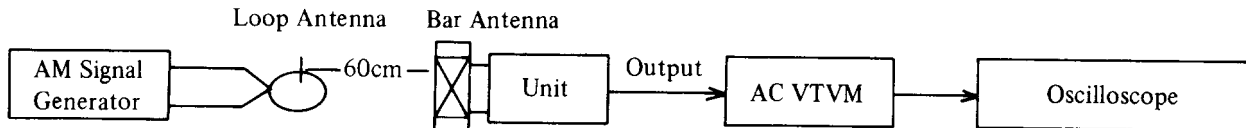

Step	Set Signal	Set Radio Dial	Adjust	VTVM reading	Remarks
1	515kHz 400Hz 30%	Lower end (515kHz)	L107	Maximum	Repeat steps 1 and 2 as necessary
2	1680kHz 400Hz 30%	Upper end (1680kHz)	TC2	Maximum	
3	600kHz 400Hz 30%	600kHz	L001 L108	Maximum	Repeat steps 3 and 4 as necessary
4	1400kHz 400Hz 30%	1400kHz	TC1 TC3	Maximum	

FM ALIGNMENT

1. FM IF ALIGNMENT

1. Set the selector switch to FM and radio dial to quiet point.
2. Connect the DC voltmeter to TP-1 terminals and the shorted wire between the TP-5 terminal on the quartz locked p.c.b. and IF OUT terminal on the front end.
3. Adjust the voltage to 0V with the T101 detector transformer lower core.
4. Remove the shorted wire after adjustment.

2. FRONT END TUNING VOLTAGE ADJUSTMENT

1. Connect the high impedance DC voltmeter across the +B terminal.
2. Turn the tuning pointer to 90MHz and adjust the indication of the fluorescent indicator tube to 90MHz with R737.
3. Turn the tuning pointer to 106MHz and adjust the indication of the fluorescent indicator tube to 106MHz with R733.
4. Repeat steps 2 and 3 until no further adjustment is necessary.
5. Set the tuning pointer to the lower frequency and check if the reading of the DC voltmeter is within $3.27 \pm 0.2V$ of the rated voltage.
6. Set the tuning pointer to the upper frequency and check if the reading of the DC voltmeter is within $27.3 \pm 0.7V$ of the rated voltage.
7. When outside the rated voltage, adjust the oscillator coil and trimmer capacitor.

3. OSCILLATOR COIL AND TRIMMER CAPACITOR ALIGNMENT

1. Set the tuning pointer to the lower frequency and adjust the voltage to 3.27V with LO oscillator coil.
2. Set the tuning pointer to the upper frequency and adjust the voltage to 27.3V with TCO trimmer capacitor.
3. Repeat steps 1 and 2 until no further adjustment is necessary.
4. To adjust the front end tuning voltage after adjustment.

4. BUFFER AMPLI. TRACKING ALIGNMENT

1. Connect the high frequency AC voltmeter across OSC OUT terminal.
2. Turn the tuning pointer to the lower frequency and adjust L721 oscillator coil for maximum output.
3. Turn the tuning pointer to the upper frequency and adjust C725 trimmer capacitor for maximum output.
4. Repeat steps 2 and 3 until no further adjustment is necessary.

5. FM FRONT END ALIGNMENT

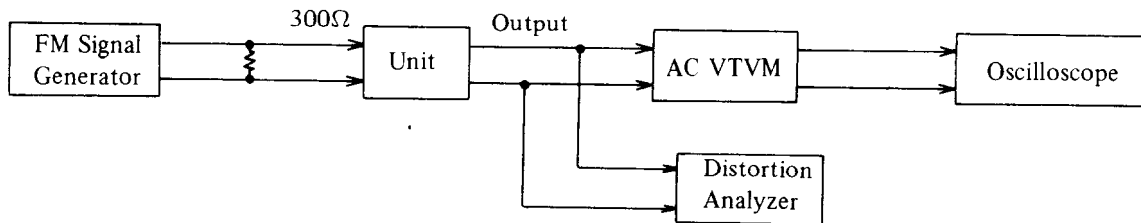

Step	FM Signal Generator	Dial to set	Adjust	Output Indicator	Adjust for	Remarks
1	98MHz 65dBf (60dB) 1kHz 75kHz devi.	98MHz	T101 Top	Distortion Analyzer	Minimum	
2	90MHz 20dBf (15dB) 1kHz 75kHz devi.	90MHz	LA, LM LR1, LR2	AC VTVM or Oscilloscope	Maximum	Repeat Steps 2 and 3 as necessary.
3	106MHz 20dBf (15dB) 1kHz 75kHz devi.	106MHz	TCA, TCR1 TCR2, TM		Maximum	
4	98MHz 65dBf (60dB) 1kHz 75kHz devi.	98MHz	IF	Distortion Analyzer	Minimum	

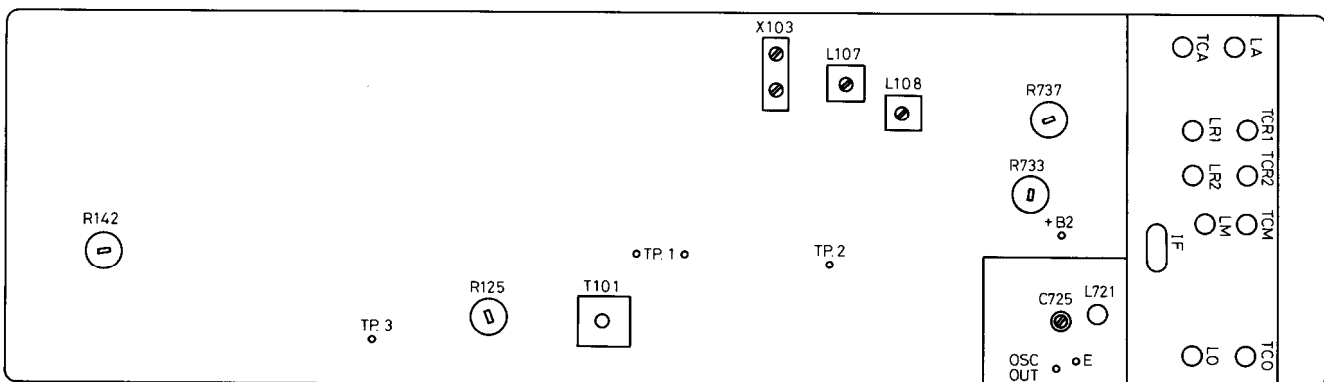

6. MULTIPLEX ALIGNMENT

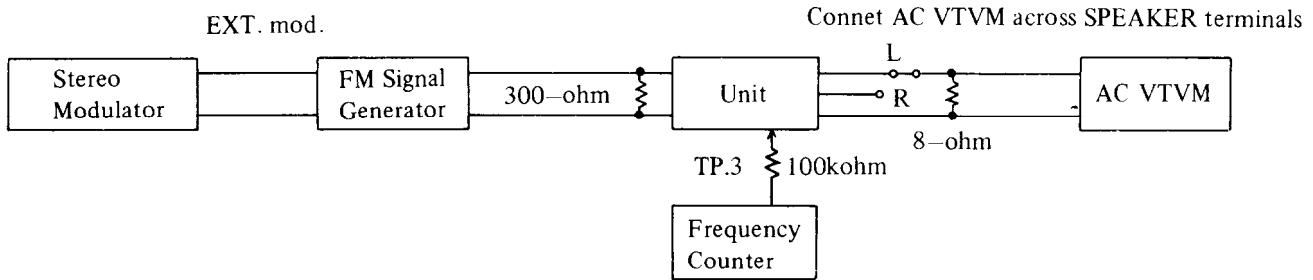

Step	FM Signal Generator	Stereo Modulator	Dial to set	Adjust	Output Indicator	Adjust for	Remarks
1	98MHz no mod. 65dBf (60dB)	—	98MHz	R125	Frequency Counter	19000±19Hz	
2	STEREO INDICATOR should light up when stereo program is being received.						
3	98MHz EXT. Mod. 65dBf (60dB)	Pilot Sig. 9% Main & Sub Sig. 1KHz Lch 91%	98MHz	R142	AC VTVM Right ch.	Minimum	Repeat Steps 3 & 4 as necessary Same and max. separation
4	Same as above	Pilot Sig. 9% Main & Sub Sig. 1KHz Rch 91%	98MHz	R142	AC VTVM Left ch.	Minimum	

7. QUARTZ LOCKED CIRCUIT ALIGNMENT

1. Connect the signal generator to the ANTENNA terminals and the DC voltmeter to the detector output (pin nos. 10).
2. Set the SG output to 98MHz, 1kHz, 75kHz devi. 65dBf (60dB).
3. Tune the receiver to 98MHz.
4. Adjust the voltage to 3.5V with a detector coil of T251.

8. TUNING METER CENTER ADJUSTMENT

1. Connect the signal generator to the ANTENNA terminals and the DC voltmeter to the detector output (pin nos. 10).
2. Set the SG output to 98MHz, 1kHz, 75kHz devi. 65dBf (60dB).
3. Tune the receiver to 98MHz.
4. Place a short circuit across TP6 (pin nos. 10 and 11).
5. Adjust the semi-fixed resistor R261 to bring the tuning meter needle to dead center.
6. Then adjust the semi-fixed resistor R268 to bring the TP7 (pin no. 14) output voltage (AFC output) to zero.

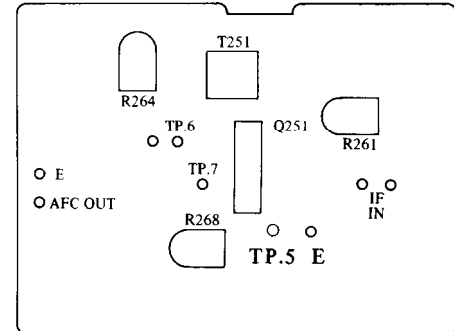

Adjustment point

9. SYNCHRONIZING THE LOCKED FREQUENCY WITH THE IF FREQUENCY

Adjust the semi-fixed resistor R264 to bring the TP7 output voltage to zero.

10. DOLBY FM CIRCUIT ADJUSTMENT

1. Set the Selector switch to DOLBY FM and remove the shorted wire between MONI OUT and NR PATH IN terminals.
2. Connect the FM signal generator to 300 ohm antenna terminals and the AC VTVM to MONI OUT terminals. (Lch. and Rch.)

Step	FM Signal Generator	Disl to set	Adjust	Output Indicator	Adjust for
1	98MHz, 400Hz, 75dBf 37.5kHz devi.	98MHz	R821 (Lch.) R822 (Rch.)	AC VTVM	775mV
2	98MHz, 5kHz 37.5kHz devi.	98MHz	FM Signal Generator	AC VTVM	59mV
3	Connect the shorted wire between MONI OUT and NR PATH IN terminals.				
4	Same as step2		R843	AC VTVM	23.4mV

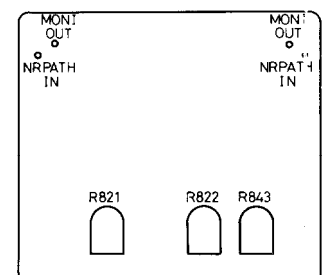

HD7490A Decade Counter

MSM-5525 RADIO FREQUENCY COUNTER/DISPLAY DRIVER

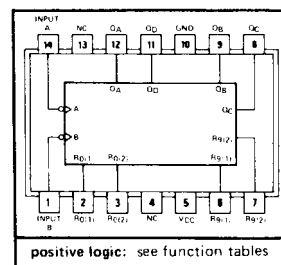
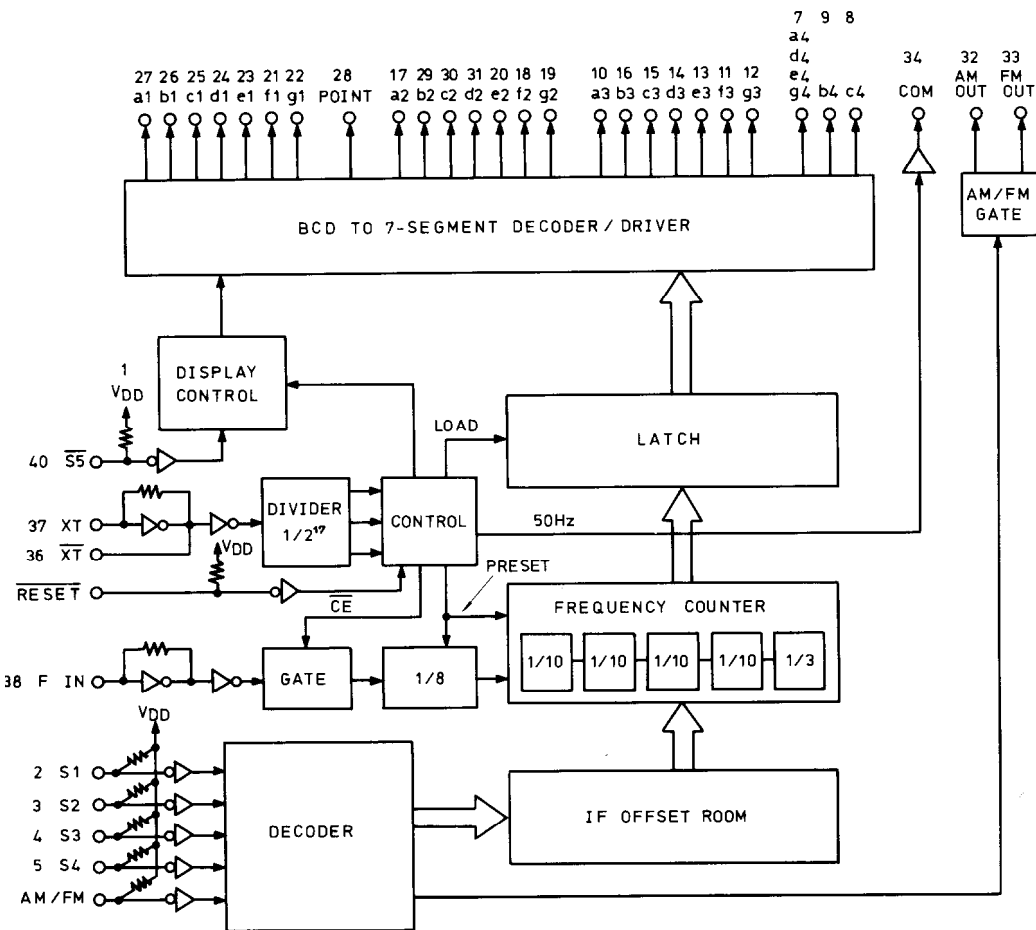

BCD COUNT SEQUENCE (See Note A)

COUNT	Q _D	Q _C	Q _B	Q _A
0	L	L	L	L
1	L	L	L	H
2	L	L	H	L
3	L	L	H	H
4	L	H	L	L
5	L	H	L	H
6	H	L	L	L
7	H	L	L	H
8	H	L	H	L
9	H	L	H	H

BI-QUINARY (5-2) (See Note B)

COUNT	Q _A	Q _D	Q _C	Q _B
0	L	L	L	L
1	L	L	L	H
2	L	L	H	L
3	L	L	H	H
4	L	H	L	L
5	H	L	L	L
6	H	L	L	H
7	H	L	H	L
8	H	L	H	H
9	H	H	L	L

RESET/COUNT FUNCTION TABLE

RESET INPUTS				OUTPUT			
R ₀ (1)	R ₀ (2)	R ₉ (1)	R ₉ (2)	Q _D	Q _C	Q _B	Q _A
H	H	L	X	L	L	L	L
H	H	X	L	L	L	L	L
X	X	H	H	H	L	L	H
X	L	X	L				COUNT
L	X	L	X				COUNT
L	X	X	L				COUNT
X	L	L	X				COUNT

- NOTES: A. Output Q_A is connected to input B for BCD count.
 B. Output Q_D is connected to input A for bi quinary count.
 C. Output Q_A is connected to input B.
 D. H = high level, L = low level, X = irrelevant

HD74S112

Dual J-K Negative Edge-Triggered Flip-Flops with Preset and Clear

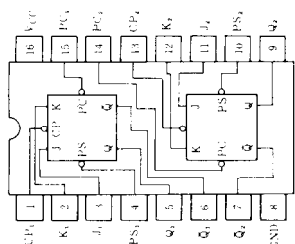

Input					Output	
PS	PC	CP	J	K	Q	Q
0	1	x	x	x	1	0
1	0	x	x	x	0	1
0	0	x	x	x	1*	1*
1	1	↓	0	0	Q	Q
1	1	↓	1	0	1	0
1	1	↓	0	1	0	1
1	1	↓	1	1	Toggle	
1	1	1	x	x	Q	Q

HA 11226 BLOCK DIAGRAM (One channel shown)

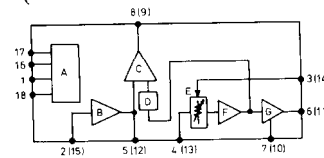

- A: POWER SUPPLY
 B: INPUT AMP
 C: ADDER
 D: OVERSHOOT SUPPRESSION
 E: VARY RESISTANS
 F: SIDE CHAIN AMP
 G: RECTIFIER AMP.

- NOTES: 1. X : irrelevant 2. ↓ : Transition from high to low level
 3. The level of Q₀ before the indicated input conditions were established.
 4. Toggle : Each output changes to the complement of its previous level on each active transition (pulse) of the clock.
 5. * : This configuration is nonstable; that is, it will not persist when present and clear inputs return to their inactive (high) level.

AM/FM TUNER SCHEMATIC DIAGRAM

- O101TA 7060P
- O102HA 1137
- O103HA 1156 W
- O104,O1052SC1312(F)
- O106HA 1151
- O107,O110,O1142SC945(A) O1
- O108,O109,O1202SC1317(R)
- O121,O1221S2688-B
- O111,O1122SC733(BL)
- O113BA402
- O115TA7136P
- O116,O117,O1182SC1317(R) or 2SC1815(Y)
- O119IN60
- O1242SC461-B
- O1252SC1815(Y)
- O731,O732VD1212
- O733YZ047
- O734WZ052
- D101,D103,D106,D1071S1555
- D108,D109,D112,D120052-7.5L
- D123,D128,D1291S1555
- D102,D104,D105,D110IN60
- D114,D115,D116,D121VD1212
- D122,D124,D126,D127YZ047
- D113,D119WZ052
- D1171S1555
- D118052-7.5L
- D51S2688-B
- D6,D7,D8,D91S1555
- D101S2688-B
- D111S1555
- D121S2688-B
- D131S1555
- D141S2688-B
- D151S1555
- D161S2688-B
- D171S1555
- D181S2688-B
- D191S1555
- D201S2688-B
- D211S1555
- D221S2688-B
- D231S1555
- D241S2688-B
- D251S1555
- D261S2688-B
- D271S1555
- D281S2688-B
- D291S1555
- D301S2688-B
- D311S1555
- D321S2688-B
- D331S1555
- D341S2688-B
- D351S1555
- D361S2688-B
- D371S1555
- D381S2688-B
- D391S1555
- D401S2688-B
- D411S1555
- D421S2688-B
- D431S1555
- D441S2688-B
- D451S1555
- D461S2688-B
- D471S1555
- D481S2688-B
- D491S1555
- D501S2688-B
- D511S1555
- D521S2688-B
- D531S1555
- D541S2688-B
- D551S1555
- D561S2688-B
- D571S1555
- D581S2688-B
- D591S1555
- D601S2688-B
- D611S1555
- D621S2688-B
- D631S1555
- D641S2688-B
- D651S1555
- D661S2688-B
- D671S1555
- D681S2688-B
- D691S1555
- D701S2688-B
- D711S1555
- D721S2688-B
- D731S1555
- D741S2688-B
- D751S1555
- D761S2688-B
- D771S1555
- D781S2688-B
- D791S1555
- D801S2688-B
- D811S1555
- D821S2688-B
- D831S1555
- D841S2688-B
- D851S1555
- D861S2688-B
- D871S1555
- D881S2688-B
- D891S1555
- D901S2688-B
- D911S1555
- D921S2688-B
- D931S1555
- D941S2688-B
- D951S1555
- D961S2688-B
- D971S1555
- D981S2688-B
- D991S1555
- D1001S2688-B

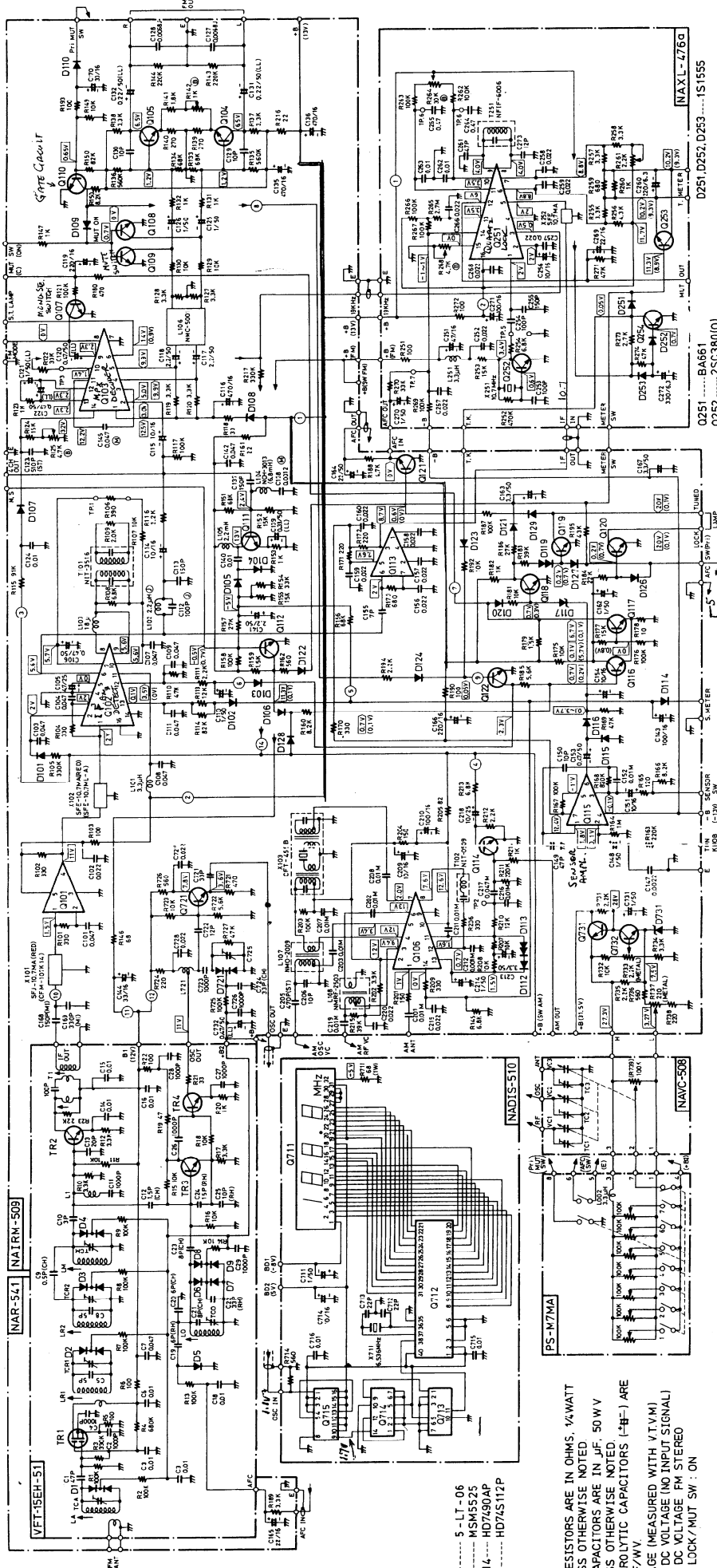

Q251BA661
 Q2522SC380(O)
 Q2532SC1317(R)
 Q2542SC945(A) O1

188.8 MHz (FRONT VIEW) 5-LT-06

MSM5525
 HA 1137
 BA 661
 HD74S112P

HA1156W
 HA1151
 HC7490A P

TA7136P
 BA402
 TA7080P

2SC1317
 2SC1815
 2SC945

2SC1312
 2SC380
 2SC733

35K45
 25C535
 25C461

(BOTTOM VIEW)

NOTES:
 ○ ALL RESISTORS ARE IN OHMS, 1/4-WATT
 ○ ALL CAPACTORS ARE IN JUF. 50 W V
 ○ UNLESS OTHERWISE NOTED
 ○ ELECTROLYTIC CAPACITORS (E-C) ARE IN JUF/WV
 ○ VOLTAGE (MEASURED WITH V.TVM)
 ○ DC VOLTAGE (NO INPUT SIGNAL)
 ○ LOCK/MUT SW: ON

POWER AMPLI. ALIGNMENT PROCEDURES

1. Set all control knobs to standard position. (See page 11)
2. Remove the bottom board.

1. BP+ VOLT LINE ADJUSTMENT

Connect the DC voltmeter between BP+ and E terminals.
Adjust the voltage to 27V with R936.

2. IDLING CURRENT ADJUSTMENT

Connect the DC voltmeter between ID and CT terminals.
Adjust the voltage to $40 \pm 10\text{mV}$ with R33.

NOTES: Adjust after switching on for five minutes.
Open load, VOLUME Minimum

3. CENTER VOLTAGE ADJUSTMENT

Connect the DC voltmeter between CT and E terminals.
Adjust the voltage to $0 \pm 10\text{mV}$ with R04.

NOTES: Adjust after switching on for five minutes.
Connect the hollow resistor across the speaker terminals.
Turn the volume control to maximum position.

PRECAUTIONS: Adjust the idling current and center voltage when the power ampli. transistor has been replaced.

4. CURRENT DETECTOR LEVEL ADJUSTMENT

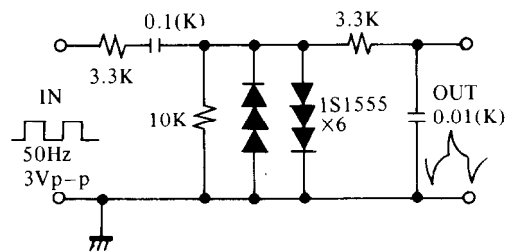
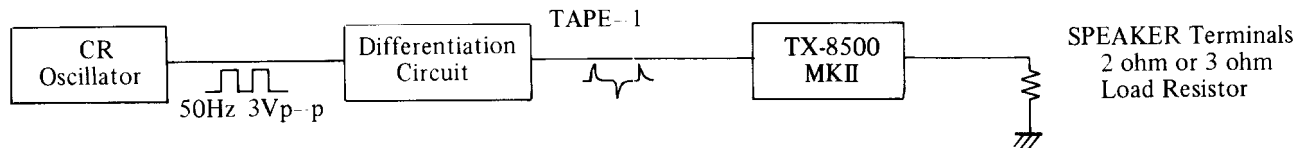

Differentiation Circuit

Apply a tone burst signal to the TAPE-1 terminal, connect a 2 ohms hollow resistor to the speaker terminals and adjust variable resistor R46 so that the relay is operated at maximum volume. Confirm that the relay is not operated when the 3 ohm hollow resistor is connected.

NOTES: Adjust after switching on for 5 minutes.
VOLUME Maximum

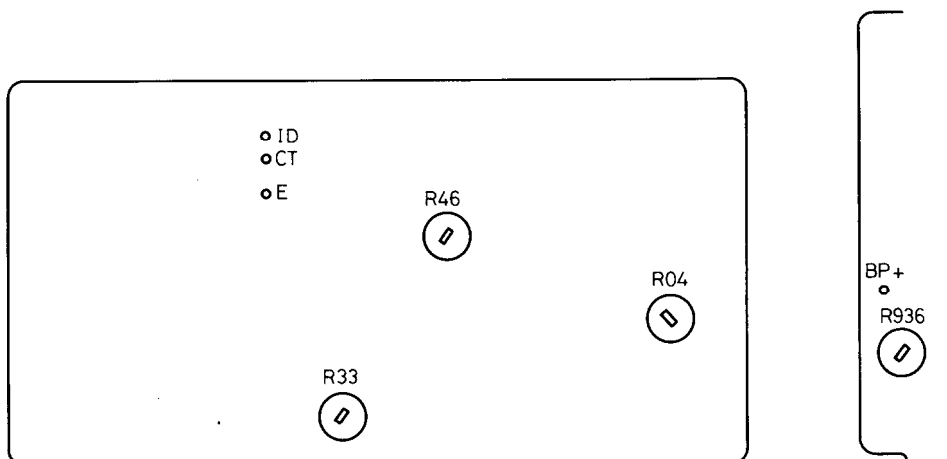

PACKING PROCEDURES

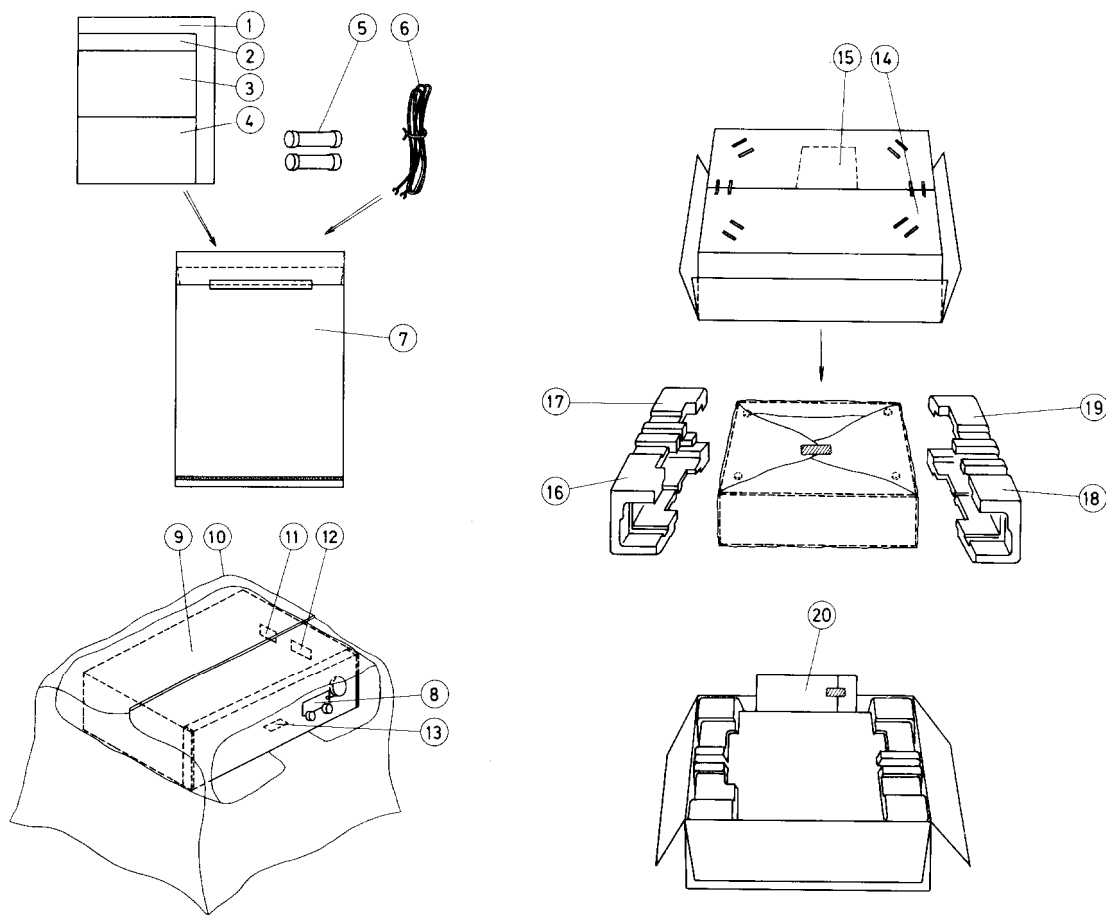

1. All printed material and accessory items are placed in the poly bag.
2. Four shorted pins are inserted in the phono terminals.
3. The Sensor tag U is attached to the Tuning shaft and it is inserted between the volume and tape switch shaft.

PARTS LIST

Ref. No.	Parts No.	Description	Ref. No.	Parts No.	Description
1	29340277	Instruction manual	11	282969	Caution label A
2	29355046	Caution card for 4	12	29360209	Cabinet composite lat
3	29358001	Service station list	13	293041	Caution label
4	29365003	Warranty card	14	29050202	Carton box
5	252050	5A (ST-6), AC fuse	15	29090358	Bottom pad
6	292064	FM antenna	16	29090288-1	Pad (RF)
7	29100006	250x350mm, Poly bag	17	29090288-2	Pad (RB)
8	29355045	Sensor tag U	18	29090287-1	Pad (LF)
9	29095085	670x1,200mm, Protection sheet	19	29090287-2	Pad (LB)
10	29100020	720x1,020mm, Poly bag	20	13689119	Accessory bag
				250153	Shorted pin

ONKYO CORPORATION

International Division: No. 24 Mori Bldg., 23-5, 3-chome, Nishi-Shinbashi, Minato-ku, Tokyo, Japan
 Telex: 2423551 ONKYO J. Phone: 03-432-6981

ONKYO U.S.A. CORPORATION

Eastern Office:
 42-07 20th Avenue, Long Island City, New York 11105, U.S.A. Phone: (212) 728-4639
 Midwest Office:
 935 Sivert Drive, Wooddale, Illinois 60191, U.S.A. Phone: (312) 595-2970