

ONKYO SERVICE MANUAL

QUARTZ SYNTHESIZED TUNER AMPLIFIER MODELS TX-870/TX-870M

BHUD, BHUDN, MBHUDN	120V AC, 60Hz
MBHUWX	120/220V AC, 50/60Hz

SAFETY-RELATED COMPONENT WARNING!!

COMPONENTS IDENTIFIED BY MARK Δ ON THE SCHEMATIC DIAGRAM AND IN THE PARTS LIST ARE CRITICAL FOR RISK OF FIRE AND ELECTRIC SHOCK. REPLACE THESE COMPONENTS WITH ONKYO PARTS WHOSE PART NUMBERS APPEAR AS SHOWN IN THIS MANUAL.

MAKE LEAKAGE-CURRENT OR RESISTANCE MEASUREMENTS TO DETERMINE THAT EXPOSED PARTS ARE ACCEPTABLY INSULATED FROM THE SUPPLY CIRCUIT BEFORE RETURNING THE APPLIANCE TO THE CUSTOMER.

TABLE OF CONTENTS

Specifications	2
Service procedures	3
Exploded view	4
Parts list	5
Block diagram-Tuner section	6
Block diagram-Amplifier section	7
IC block diagram and descriptions	8
Adjustment procedures	18
Pc board view/parts list	21
FM/AM tuner	21
Display/Operation switch	23
Pre. and power amplifier	25
Tone control	28
Power supply	29
Volume/Volume indicator	30
Packing view	31

ONKYO
AUDIO COMPONENTS

SPECIFICATIONS

AMPLIFIER SECTION

Power Output:	105 watts per channel, min. RMS, at 8 ohms, both channels driven, from 20Hz to 20kHz, with no more than 0.025% total harmonic distortion
Total Harmonic Distortion:	
IM Distortion:	0.025% at rated power
Damping Factor:	80 at 8 ohms
Frequency Response:	20-30,000Hz \pm 1dB
RIAA Deviation:	20-20,000Hz \pm 0.5dB
Sensitivity and Impedance:	Phono: 2.5mV/50kohms Phono (MC): 350 μ V/330 ohms CD/Tape Play: 150mV/50kohms Tape Rec: 150mV/3.5kohms Main In: 1V/47kohms
Phono Overload:	150mV RMS at 1kHz, 0.025% THD
Signal-to-Noise Ratio:	Phono (MM): 93dB (at 10mV input, A weighted) 75dB (IHF A-202) Phono (MC): 88dB (at 5mV input, A weighted) 67dB (IHF A-202) CD/Tape: 98dB (A weighted) 80dB (IHF A-202)
Tone Controls:	Bass: \pm 10dB at 100Hz Treble: \pm 10dB at 10kHz
Muting:	-20dB

TUNER SECTION:

FM:

Tuning Range:	87.5-108.0MHz (50kHz steps or 25kHz steps)
Usable Sensitivity:	Mono: 10.8dBf, 1.9 μ V Stereo: 17.2dBf, 4.0 μ V
50dB Quieting Sensitivity:	Mono: 17.2dBf, 4.0 μ V Stereo: 37.2dBf, 40 μ V
Capture Ratio:	1.5dB
Image Rejection Ratio:	45dB
IF Rejection Ratio:	90dB
Signal-to-Noise Ratio:	Mono: 73dB Stereo: 67dB
Alternate Channel Attenuation:	65dB
AM Suppression Ratio:	50dB
Harmonic Distortion:	Mono: 0.1% Stereo: 0.2%
Frequency Response:	30-15,000Hz \pm 1.5dB
Stereo Separation:	45dB at 1kHz/30dB at 100-10,000Hz
Tuning Level:	27/17dBf

AM:

Tuning Range:	530-1620kHz (10kHz steps) and/or 522-1611kHz (9kHz steps) (Worldwide model)
Usable Sensitivity:	30 μ V
Image Rejection Ratio:	40dB
IF Rejection Ratio:	40dB
Signal-to-Noise Ratio:	40dB
Harmonic Distortion:	0.7%

GENERAL

Power Supply:	
USA & Canadian models:	AC120V, 60Hz
Worldwide models:	120 and 220V switchable, 50/60Hz
Dimensions (W \times H \times D):	435(465) \times 157(158) \times 432(432)mm 17-1/8"(18-5/16") \times 6-3/16"(6-3/16") \times 17"(17")
Weight:	13.2(14.6)kg, 29.1(32.2)lbs *() indicate worldwide models.

REMOTE CONTROL TRANSMITTER RC-118S

Transmitter: Infrared
 Signal range: Approx. 5meters(16ft.4")
 Power supply: TWO "AA" batteries (1.5V×2)
 Dimensions(W×H ×D): 64×18×176mm
 2-1/2 " ×3/4 " × 7"
 Weight: 140grams 5.0oz.(including batteries)

Specifications and features are subject to change without notice.

SERVICE PROCEDURES**1. Replacing the fuses**

For continued protection against fire hazard, replace only with same type and same rating fuse.

D (120V) model

Circuit no.	Part no.	Description
F901	252052	7 A (ST-6), Primary

W (Worldwide) model

Circuit no.	Part no.	Description
F901	252052	7 A (ST-6), Primary
F902	252077	4 A-SE-EAK, Primary

2. Change of AM band step.

With the exception of the models below, a BAND STEP selector switch is not provided.

BAND STEP	D763, JL009
10kHz→ 9kHz	Additional
9kHz→10kHz	Eliminated

In D763 ISS133 (Part No. 223163) is used. Between #1 and #2 of JL009 a jumper lead must be inserted. (Refer to page 23)

– Worldwide model –

Worldwide models are equipped with a step band selector switch. This switch is located on the back panel. This switch is set to 10kHz and 9kHz at the factory, but may have to be reset to 9kHz or 10kHz depending on the area where the unit is used.

	De-emphasis	AM step
Europe:	50μsec	9kHz
U.S.A.:	75μsec	10kHz

3. Change of voltage

Worldwide models are equipped with a voltage selector to conform with local power supplies. This switch is located on the back panel. Be sure to set this switch to match the voltage of the power supply in your area before turning the power switch on.

This switch is set to 220V at the factory. Voltage is changed by sliding the groove in the switch with the screwdriver to the right or left. Confirm that the switch has been moved all the way to the right or left before turning the power switch on.

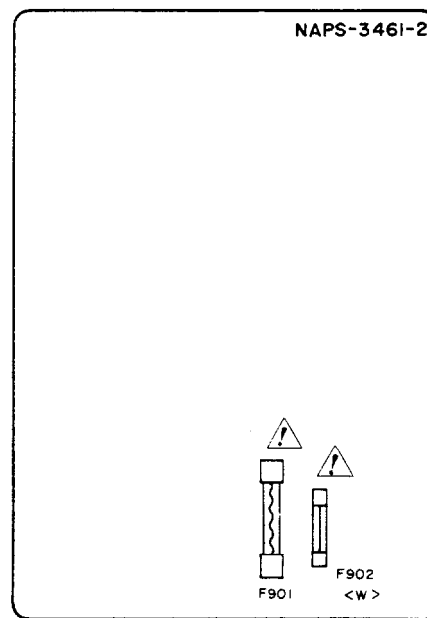

POWER SUPPLY CIRCUIT PC BOARD

4. Safety-check out

(Only U.S.A. model)

After correcting the original service problem perform the following safety check before releasing the set to the customer.

Connect the insulating-resistance tester between the plug of power supply cord and terminal GND on the back panel. Specifications: 3.3 Mohm ±10% at 500V.

5. Memory preservation

This unit does not require memory preservation batteries. A built-in memory power back-up system preserves contents of the memory during power failures and even when the unit is unplugged. The unit must be plugged in and the power switch turned on and off once in order to charge the back-up system. Note that since this is not a permanent memory the power switch must be turned on and off a few times each month to keep the back-up system operative. The period of time during which memory contents are preserved after power has last been turned off varies depending on climate and placement of the unit. On the average, memory contents are protected over a period of 3 to 4 weeks (a minimum of 2 weeks) after the last time power has been turned off. This period is shorter when the unit is exposed to very high humidity or used in an area with an extremely humid climate.

EXPLODED VIEW

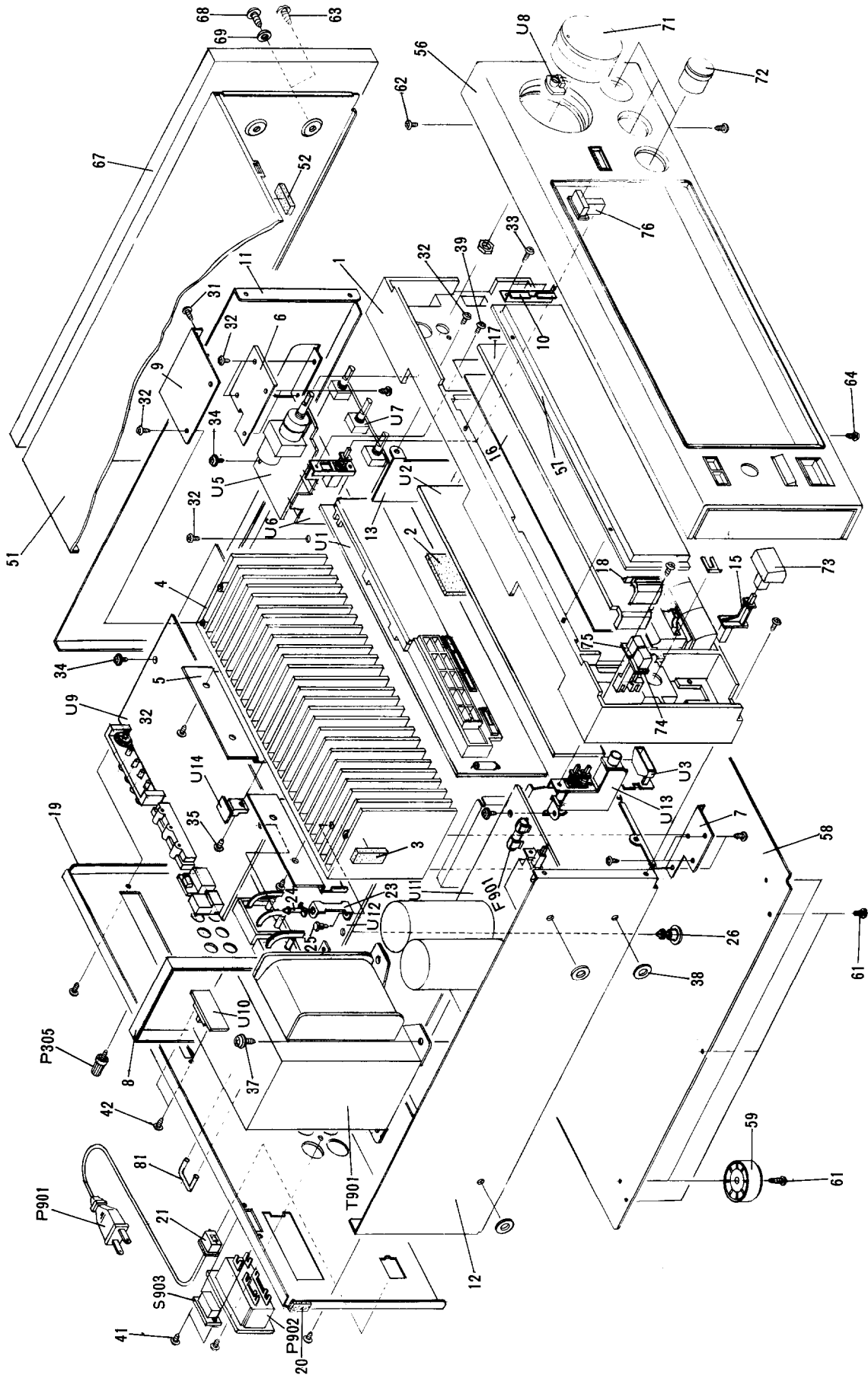

PARTS LIST

REF. NO.	PART NO.	DESCRIPTION	REF. NO.	PART NO.	DESCRIPTION	REF. NO.	PART NO.	DESCRIPTION
1	27110457B	Front bracket ass'y	51	28184419A	Top cover	U1	1A121552-2	NADIS-3452-2, Display circuit pc board ass'y
2	28140923	t3 × 60 × 45, Cushion	52	28140020	t4 × 10 × 40, Cushion	U2	1A121553-2	NASW-3453-2, Operation switch pc board ass'y<D>
3	28140927	t2 × 30 × 10, Cushion	56	1A121121	Front panel ass'y	U3	1A121554-2	NASW-3454-2, Stand-by switch pc board ass'y
4	27160236A	Radiator	57	28191491A	Clear plate —	U4	1A122553-2A	NASW-3453-2A, Operation switch pc board ass'y<W>
5	27130435	Bracket, transistor	58	27170254B	Bottom board	U5	1A121556-2	NAAF-3456-2, Volume pc board ass'y
6	27141301	Bracket HR	59	27175153	Leg	U6	1A121557-2	NASW-3457-2, Mode switch pc board ass'y
7	27141302	Bracket HL	61	834430088	3TTS+8B(BC), Tapping screw	U7	1A121558-2	NAAF-3458-2, Tone control circuit pc board ass'y
8	27141321	Bracket, power transformer	62	833430080	3TTP+8P(BC), Tapping screw	U8	1A121559-2	NADIS-3459-2, Volume indicator pc board ass'y
9	27141322-1	Bracket R	63	838440089	4TTB+8C(BC), Tapping screw	U9	1A121560-2	NARF-3460-2, FM/AM tuner pc board ass'y<D>
10	27141300	Bracket S	64	834430108	3TTF+10B(BC), Tapping screw	U10	1A122567-2	NASW-3467-2, De-emphasis switch pc board ass'y<W>
11	27115240A	Side bracket R	66	28185340A	Side panel L<W>	U11	1A121561-2	NAPS-3461-2, Power supply circuit pc board ass'y<D>
12	27130564A	Bracket, power transformer	67	28185342A	Side panel R<W>	U12	1A121562-2	NAAF-3462-2, Pre. and power amplifier pc board ass'y
13	27130565A	Bracket F	68	836440303	4STV+30CQ(BC), Tapping screw<W>	U13	1A121563-2	NASW-3463-2, Speaker switch pc board ass'y
15	27273111	Joint, power	69	870086	W4 × 12(BC), Special Washer<W>	U14	1A121564-2	NAETC-3464-2, Power supply transistor pc board ass'y
16	28133212	Back plate	71	28323558	Knob VOLUME	U15	1A121565-2	NAETC-3465-2, Power supply transistor pc board ass'y
17	28130252	Dial plate	72	28323559	Knob TONE			
18	27190686	Holder, dial plate	73	28323241A	Knob POWER			
19	27121195	Back panel <D>	74	28323314	Knob SPEAKER A			
20	28140020	Back panel <W>	75	28323316	Knob SPEAKER B			
21	27300750	Strainrelief	76	28323560	Knob PUSH			
23	27141200A	Bracket, pc board	81	27141033	Connection plug(pre out-main in)			
24	27190062	KGLS-12S, Holder	F901	252052	7A(ST-6), Primary fuse			
25	880009	Rivet	F902	252077	4A-SE-EAK, Primary fuse<W>			
26	27190693	KGLS-6R, Holder	P305	25060044	Terminal GND			
31	838430068	3TTB+6B(BC), Tapping screw	P901	253123, 253136,	AS-UC-6 #18, Power supply cord			
32	834430088	3TTS+8B(BC), Tapping screw		253140 or				
33	833430080	3TTP+8P(BC), Tapping screw	P902	253146				
34	831130088	3TTW+8B, Tapping screw	Q525, Q526	25050293	NSCT-6P120, AC outlet			
35	834430108	3TTS+10B(BC), Tapping screw	Q529, Q530	2201703, 2201704 or	2SC3855-O, 2SC3855-Y or			
36	834230108	3TTS+10B(Ni), Tapping screw	Q527, Q528	2201706, 2201693,	2SC3855-P, Power transistor			
37	830440089	4TTC+8C(BC), Tapping screw	Q531, Q532	2201694 or	2SA1491-O			
38	27270212	Spacer	S903	2201696	2SA1491-P, Power transistor			
39	82143006	3P+6FN(BC), Pan head screw	T901	2300381	NSS-1258P, Voltage selector switch<W>			
40	833426060	2.6TTP+6P(BC), Tapping screw for U2		2300382	NPT-1017D, Power transformer<D>			
41	82143006	3P+6FN(BC), Pan head screw<Voltage selector switch><W>			NPT-1017DG, Power transformer<W>			
42	82142604	2.6P+4F(BC), Pan head screw<Band/De-emphasis switch><W>						

NOTE: <D>: Only 120V model
<W>: Only Worldwide model

NOTE: THE COMPONENTS IDENTIFIED BY MARK Δ ARE CRITICAL FOR RISK OF FIRE AND ELECTRIC SHOCK. REPLACE ONLY WITH PART NUMBERS SPECIFIED.

BLOCK DIAGRAM

— TUNER SECTION —

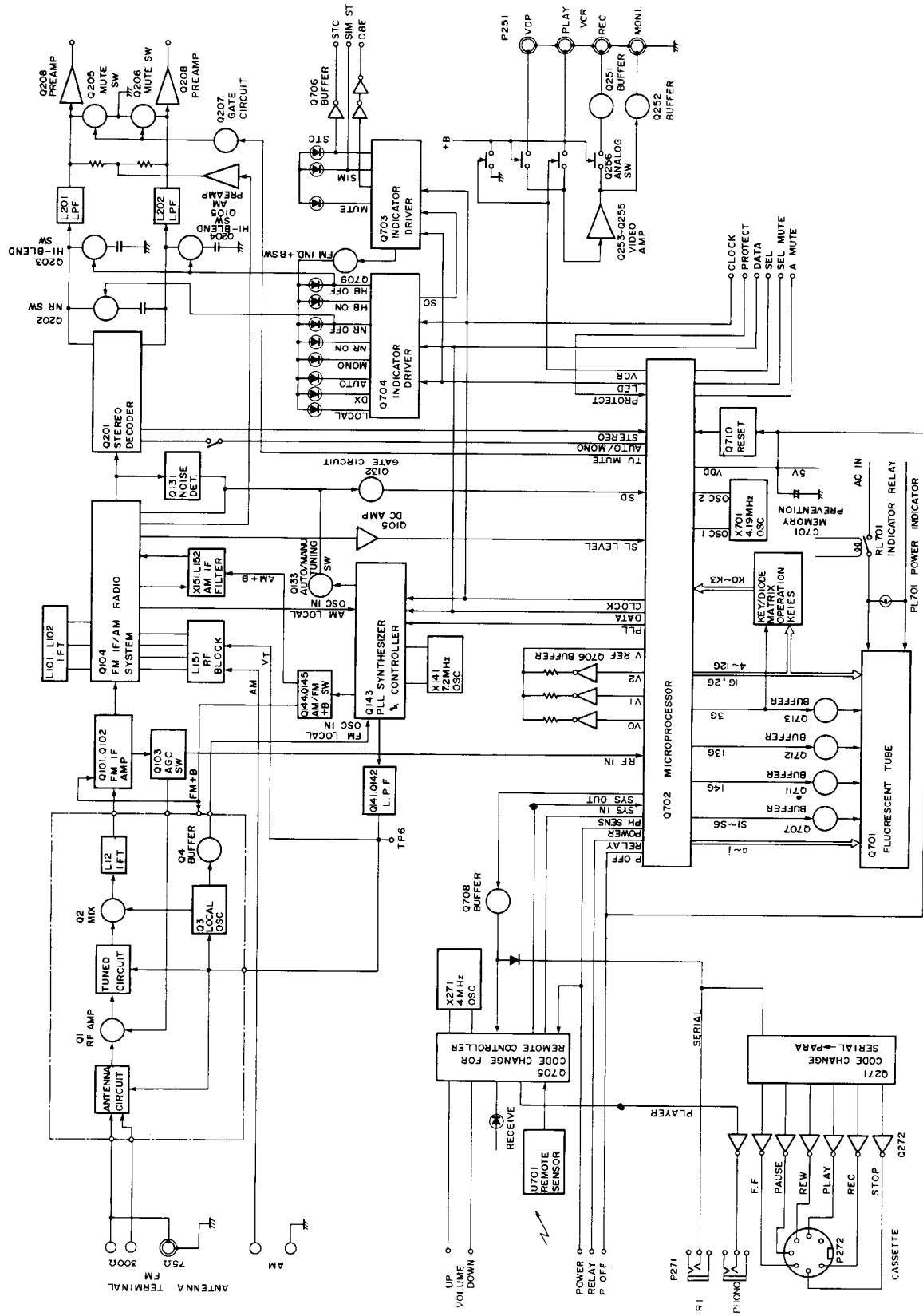

AMPLIFIER SECTION

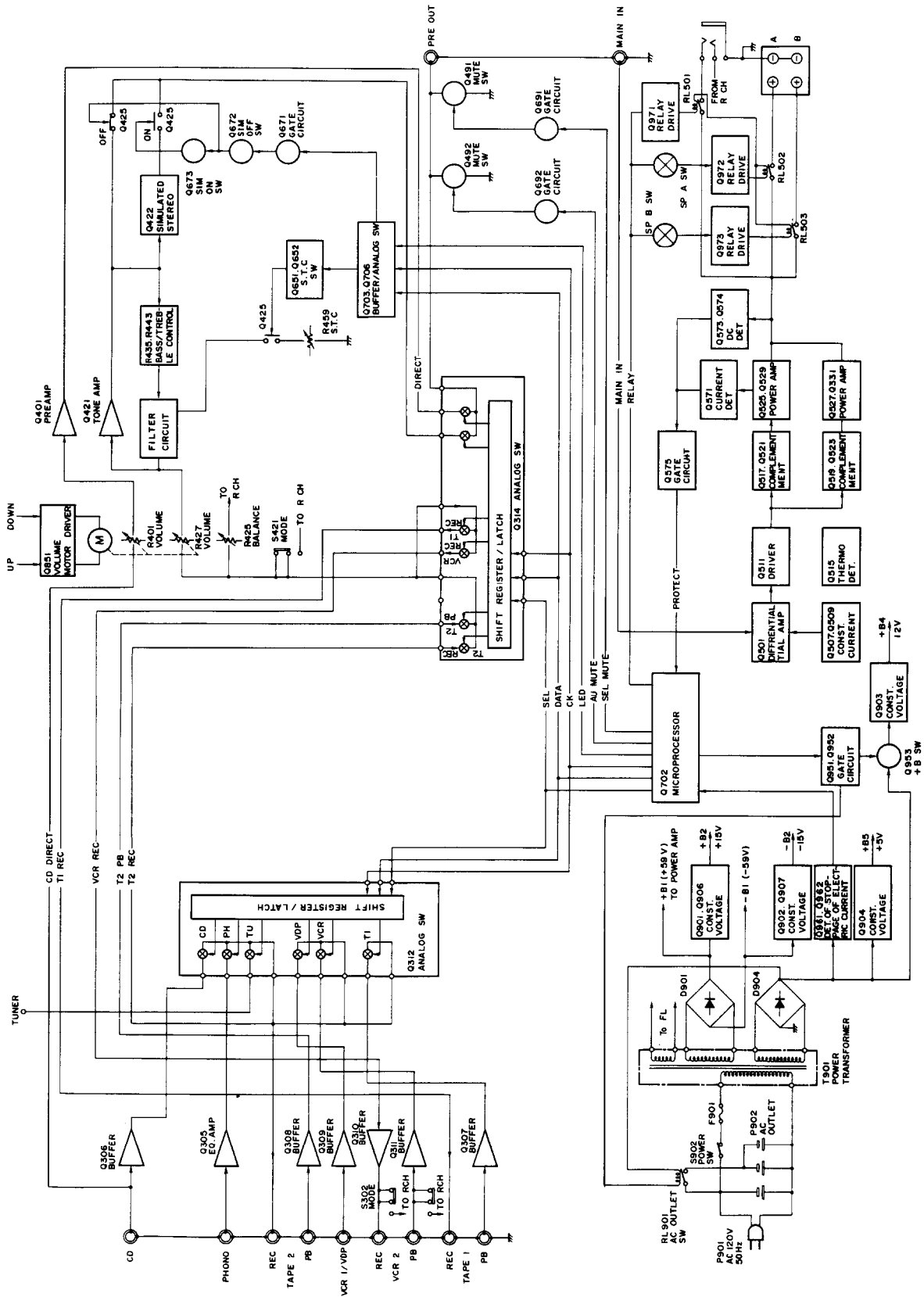

IC BLOCK DIAGRAM AND DESCRIPTIONS

HA12016 (FM STEREO DECODER)

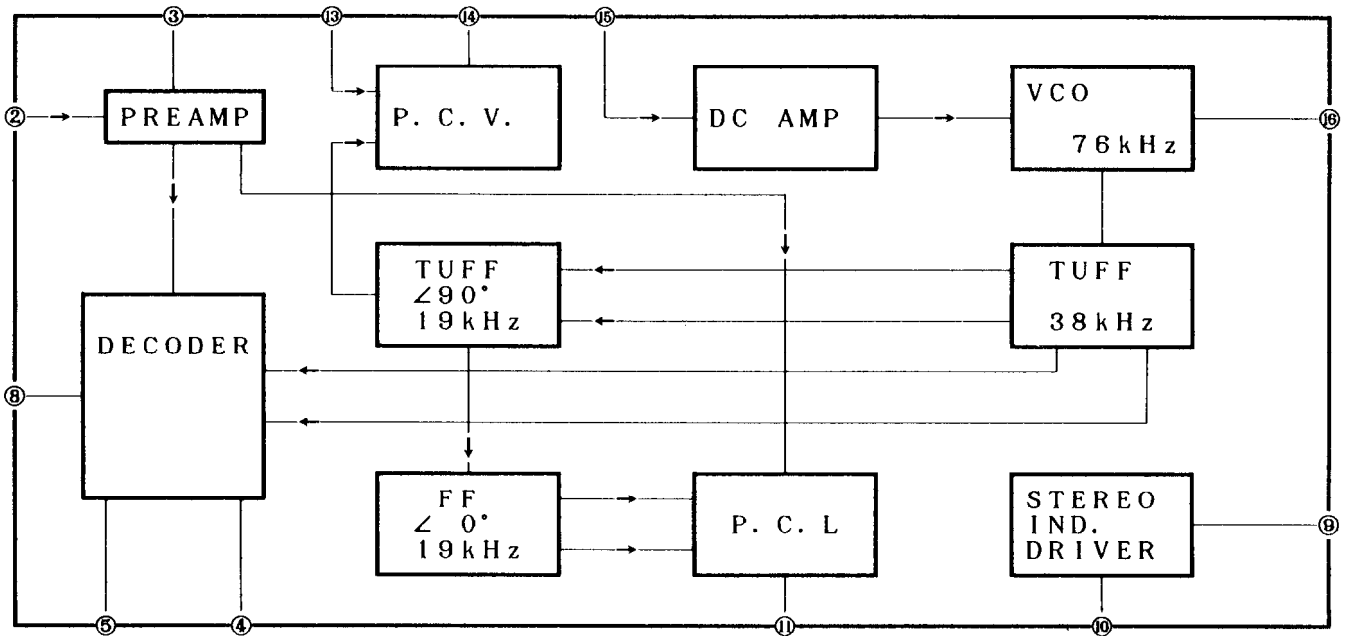

LC4966 (ANALOG SWITCH)

4069UB (HEX INVERTER)

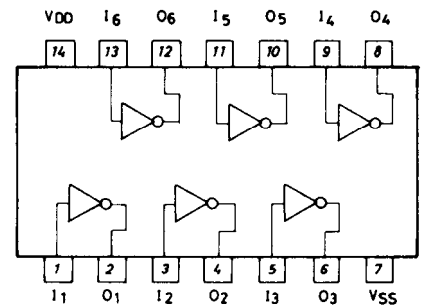
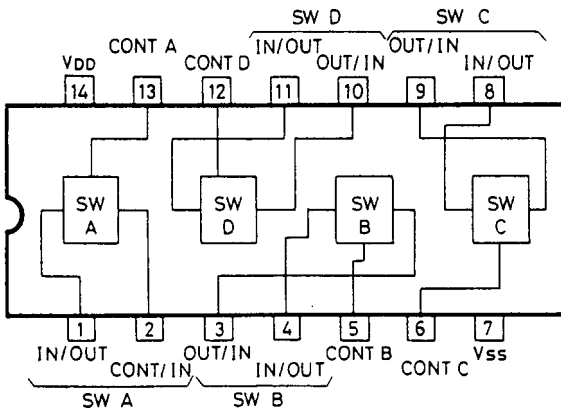

μPA81C (INVERTER/BUFFER)

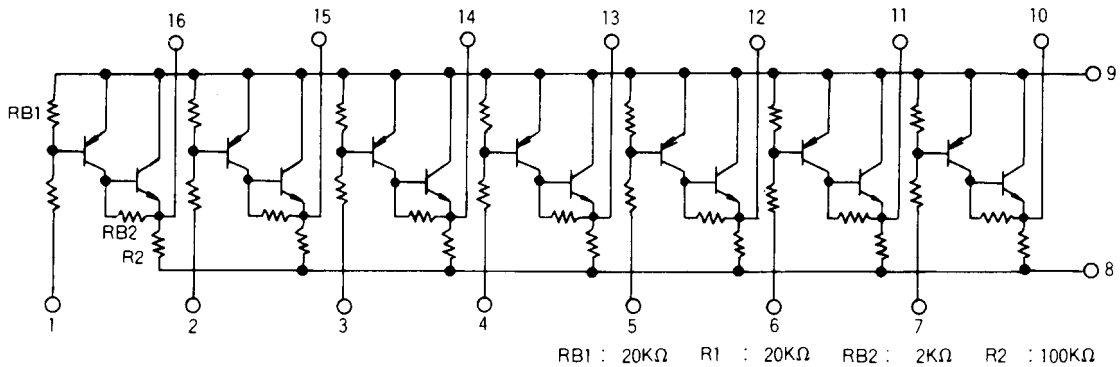

LA1266A (FM IF AND AM RADIO SYSTEM)

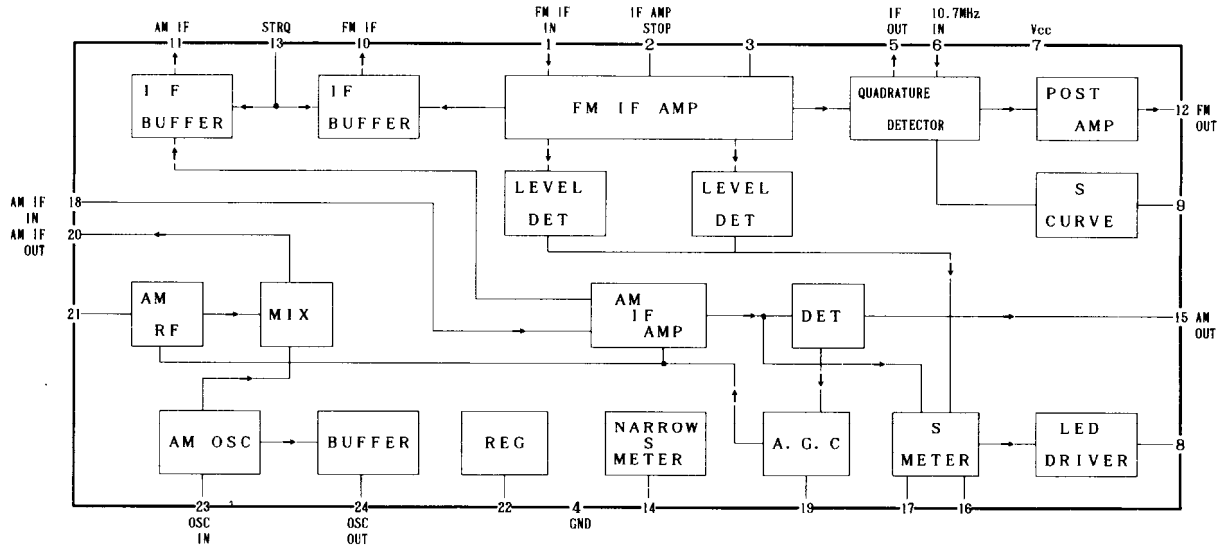

LB1630 (MOTOR DRIVER)

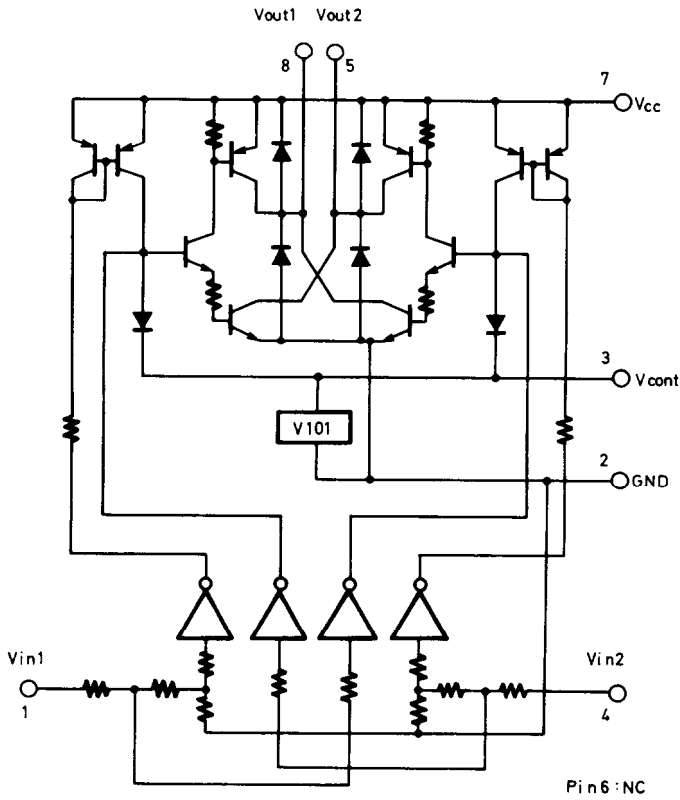

TRUTH TABLE

IN 1	IN 2	OUT 1	OUT 2	MOTOR
H	L	H	L	Normal
L	H	L	H	Reverse
H	H	OFF	OFF	Wait
L	L	OFF	OFF	Wait

NJM4565DD/NJM4558DX/
μPC4570C (OP. AMP)

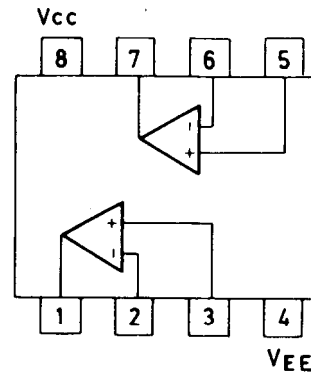

4066B (ANALOG SWITCH)

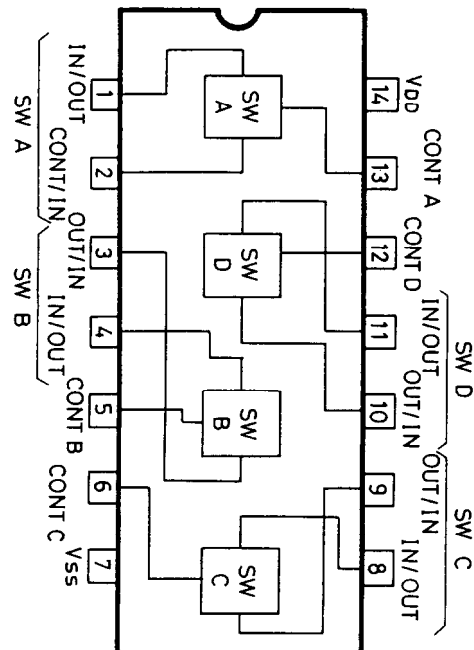

LC6538D-3838 (MICROPROCESSOR)

Pin No.	Symbol	Description
1	D14	These are the digit and key scan signal output terminals. "H" when active. Refer to the key and diode matrix.
2	D13	
3	D12	
4	D11	
5	D10	
6	D9	
7	D8	
8	D7	
9	D6	
10	D5	
11	D4	
12	D3	
13	D2	
14	D1	
15	VDD	Power supply terminal. (+5V)
16	OSC1	Connect to the 4.19MHz ceramic oscillator.
17	OSC2	
18	VSS	Ground terminal.
19	TEST	Test terminal. Connect to the ground.
20	RES	This is the input terminal for reset when the power switch turns on. "L" when active.
21	X1	Sub clock terminal. Not used. Terminal X1 Connects to the ground.
22	X2	
23	POWER	This is the output terminal for power source. It is "H" for power on. This signal controls to the power supply circuit and the relay for AC outlet.
24	RELAY	This is the output terminal for control of the speaker and headphone relays. "H" when active.
25	VDP	These are the output terminals for control of video signal.
26	VCR	
27	PHONO	This is the output terminal for control of record player. "L" when the source selector is PHONO
28	MUTING	This is the output terminal for muting control. "H" when active.
29	SEL MUTE	This is the muting output terminal when the selector key is operated. "H" when active.
30	TUNER MUTE	This is the output terminal for muting control of tuner section. "H" when active.
31	K0	These are the input terminals for key return signal source and diode matrix. "H" when active.
32	K1	
33	K2	
34	K3	
35	S IN	This is the signal strength input terminal.
36	SD	Auto stop signal input terminal. Auto tuning stops when this terminal becomes to the high level
37	STEREO	This is the input terminal for detection of the stereo broadcast. "L" when active.
38	RF IN	This is the input terminal for RF level.
39	LED	This is the output terminal for indicator LED driver. Connect to terminal LAT of μ PD6345C.
40	VREF	This is the input terminal for comparator reference voltage.
41	AUTO/MONO	This is the AUTO/MONO switching output terminal. "L" when AUTO.
42	PLL	Connect to the terminal CE of PLL IC (LM7001).
43	DATA	This is the serial data output terminal. Connect to the terminal DATA of PLL IC, and terminal DI of LED driver (μ PD6345C), and terminal DI of analog switches (LC7821/LC7822).
44	CL	This is the serial clock output terminal. Connect to the terminal CI of PLL IC, and terminal SCK of LED driver, and terminal CL of analog switches.
45	SEL	Connect to the terminal SEL of analog switches.
46	$\overline{V0}$	These are the output terminals for comparator reference voltage. Refer to the signal level indicator circuit.
47	$\overline{V1}$	
48	$\overline{V2}$	
49	P OFF	This is the input terminal for detection of the stoppage of electric current. "L" when the stoppage of electric current.
50	PROTECT	This is the detection terminal for protection circuit. The speaker and headphone relays turn off when this terminal become to the high level.
51	SYSTEM OUT	This is the output terminal for system code. "L" when active.
52	SYSTEM IN	This is the input terminal for system code. "H" when active.

Pin No.	Symbol	Description	
53	DISPLAY	This is the display output terminal. This signal controls to the static indication section of fluorescent tube. "L" when active.	
54 55 56 57 58 59 60 61	Sa Sb Sc Sd Se Sf Sg Sh	These are the segment signal output terminals. "H" when active.	
62	VP		Pull-down resistor connection terminal of FIP controller/driver.
63 64	Si Sj		These are the segment signal output terminals. "H" when active.

KEY AND DIODE MATRIX

	K3 (#34)	K2 (#33)	K1 (#32)	K0 (#31)
D1 (#14)	M4	M3	M2	M1
D2 (#13)	M8	M7	M6	M5
D3 (#12)	MEMORY	SHIFT	M10	M9
D4 (#11)	TU LEVEL	FM MUTE	UP	DOWN
D5 (#10)	CD DIRECT	POWER	APR	ANT
D6 (#9)	AM	FM	PHONO	CD
D7 (#8)	TAPE 2	TAPE 1	VCR	VDP
D8 (#7)	SIM STEREO	STC	DBE	REC SEL
D9 (#6)				AUTO/MONO
D10 (#5)	SYS DIS(1)	TI DIS(0)	AM9K(0/1)	MODE

ALTERNATE KEY
DIODE MATRIX

AM9K (AM band step setting diode matrix)

D763	Frequency range	Channel space	Refernce frequency	IF frequency
0	530~1620kHz	10kHz	10kHz	450kHz
1	522~1611kHz	9kHz	9kHz	450kHz

SIGNAL LEVEL INDICATOR CIRCUIT

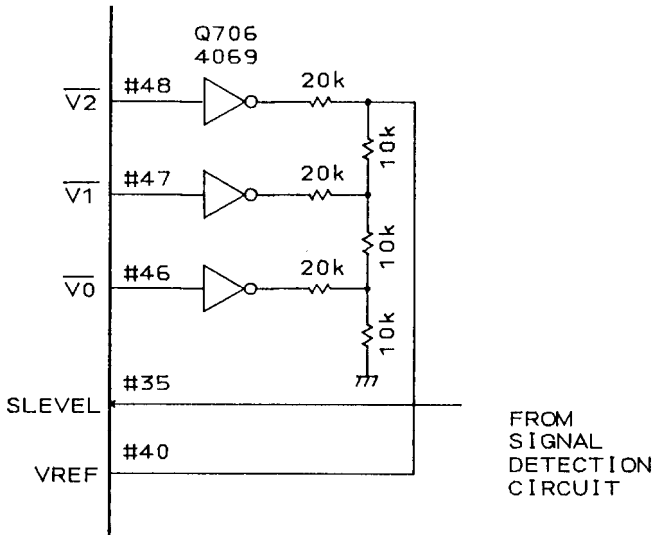

Output terminals			Signal strength indicator
V2	V1	V0	
H	H	H	Light off
H	H	L	Light off
H	L	H	1st on
H	L	L	2nd on
L	H	H	3th on
L	H	L	4th on
L	L	H	5th on
L	L	L	5th on

LC7821 (Analog switch)

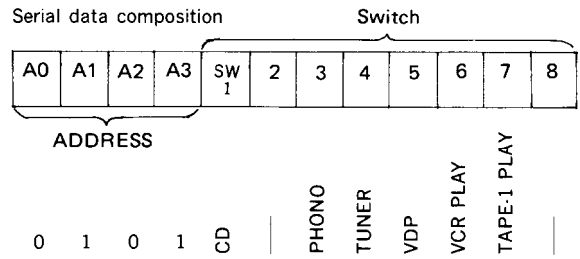
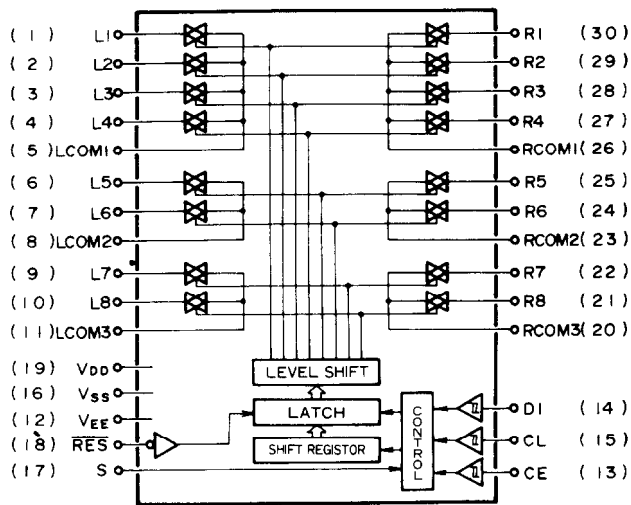

(Q312)

Pin No.	Terminal	Description	Pin No.	Terminal	Description	
1	CD	Input/output terminals of audio signal of right channel. Control to the inside analog switch at the serial data.	16	V _{SS}	Ground terminal.	
2	—		17	S	Selector terminal.	
3	PHONO		Input/output terminals of audio signal of left channel. Control to the inside analog switch at the serial data.	18	RES	Reset terminal. When power is turned ON, the condition of the analog switch is not determined, but when this terminal is "L", all analog switches are OFF.
4	TUNER			19	V _{DD}	Power supply terminal. (+15V)
5	L COM 1			20	R COM 3	Input/output terminals of audio signal of left channel. Control to the inside analog switch at the serial data.
6	VDP			21	—	
7	VCR PLAY			22	TAPE 1 PLAY	
8	L COM 2			23	R COM 2	
9	TAPE 1 PLAY			24	VCR PLAY	
10	—			25	VDP	
11	L COM 3			26	R COM 1	
12	V _{EE}	27		TUNER		
13	CE	28		PHONO		
14	DI	29	—			
15	CL	30	CD			

LC7822 (ANALOG SWITCH)

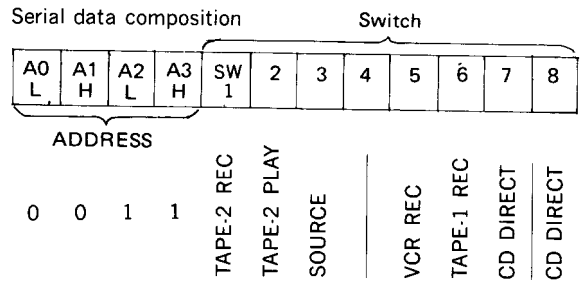
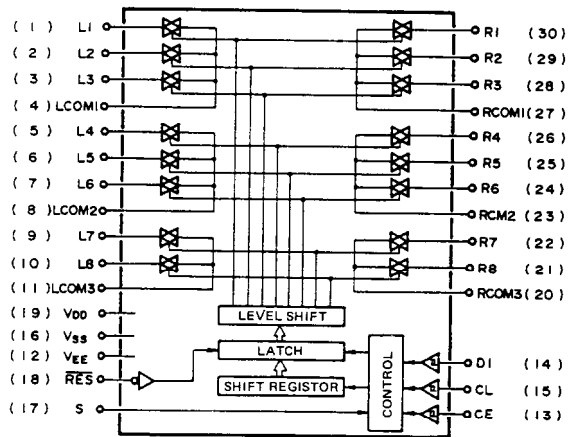

(Q314)

Pin No.	Terminal	Description	Pin No.	Terminal	Description
1	TAPE 2 REC	Input/output terminals of audio signal of right channel. Control to the inside analog switch at the serial data.	16	V _{SS}	Ground terminal.
2	TAPE 2 PB		17	S	Selector terminal.
3	SOURCE		18	RES	Reset terminal. When power is turned ON, the condition of the analog switch is not determined, but when this terminal is "L", all analog switches are OFF.
4	L COM 1		19	V _{DD}	Power supply terminal. (+5V)
5	VCR REC		20	R COM 3	Input/output terminals of audio signal of left channel. Control to the inside analog switch at the serial data.
6	TAPE 1 REC		21	CD DIRECT	
7	L COM 2		22	CD DIRECT	
8	L COM 2		23	R COM 2	
9	CD DIRECT		24	TAPE 1 REC	
10	CD DIRECT		25	VCR REC	
11	L COM 3		26		
12	V _{EE}	27	R COM 1		
13	CE	28	SOURCE		
14	D1	29	TAPE 2 PB		
15	CL	30	TAPE 2 REC		

μPD6345C (INDICATOR LED DRIVER)

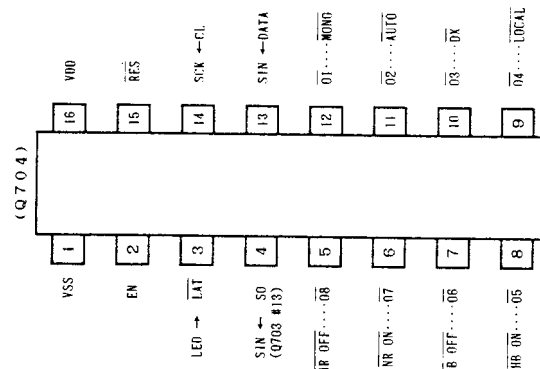
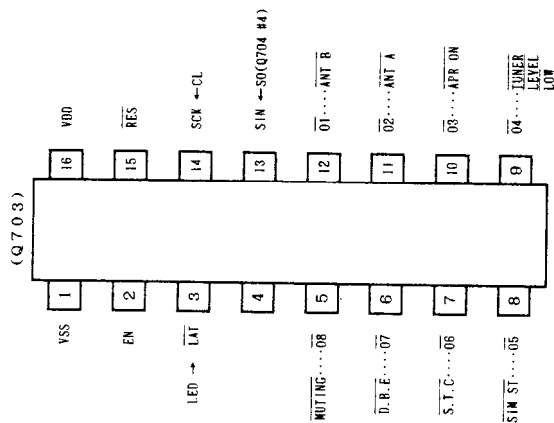

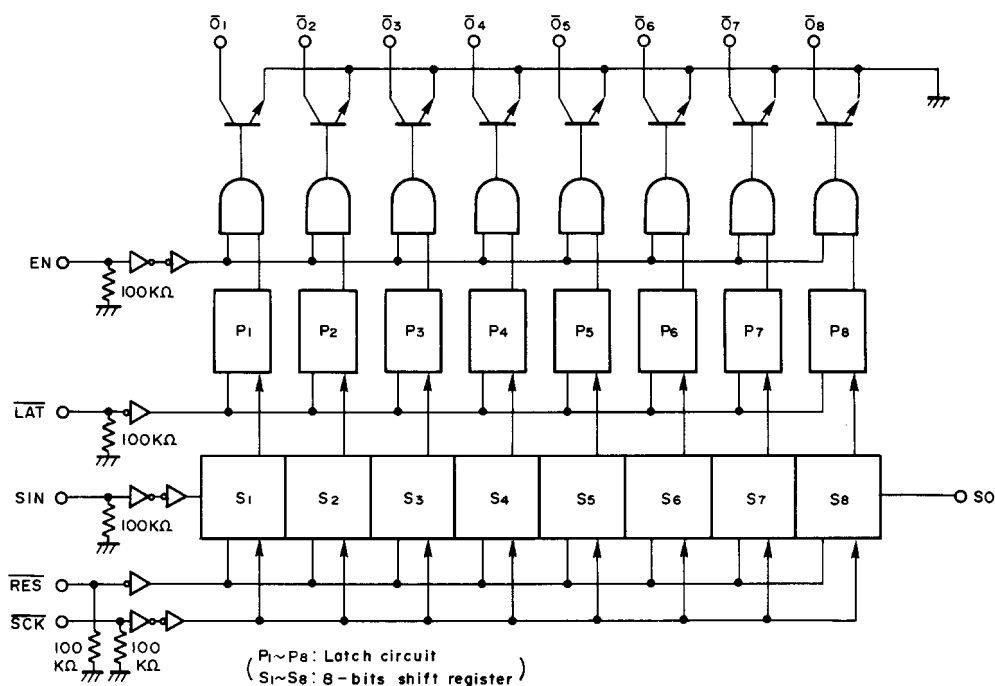

(Q704)

(Q703)

Pin No.	Symbol	Descriptions	Pin No.	Symbol	Descriptions
1	VSS	Ground terminal.	1	VSS	Ground terminal.
2	EN	Enable terminal. Connect to 5V.	2	EN	Enable terminal. Connect to 5V.
3	$\overline{\text{LAT}}$	Latch terminal. Connect to the terminal LED of LC6538D-3838.	3	$\overline{\text{LAT}}$	Latch terminal. Connect to the terminal LED of LC6538D-3838.
4	S0	Serial data output terminal. Connect to terminal SIN of $\mu\text{PD6345C}$ (Q703)	4	S0	Serial data output terminal.
5~12	$\overline{\text{O8}} \sim \overline{\text{O1}}$	Data output terminals. Connect to the indicator L. E. Ds.	5~12	$\overline{\text{O8}} \sim \overline{\text{O1}}$	Data output terminals. Connect to the indicator L. E. Ds.
13	SIN	Serial data input terminal. Connect to the terminal DATA of LC6538D-3838.	13	SIN	Serial data input terminal. Connect to the terminal S0 of $\mu\text{PD6345C}$ (Q704).
14	SCK	Serial clock input terminal. Connect to the terminal CL of LC6538D-3838.	14	SCK	Serial clock input terminal. Connect to the terminal CL of LC6538D-3838.
15	$\overline{\text{RES}}$	Reset input terminal. "L" when active.	15	$\overline{\text{RES}}$	Reset input terminal. "L" when active.
16	VDD	Power supply terminal. (+5V)	16	VDD	Power supply terminal. (+5V)

LC6527C-3802 (CODE CHANGER)

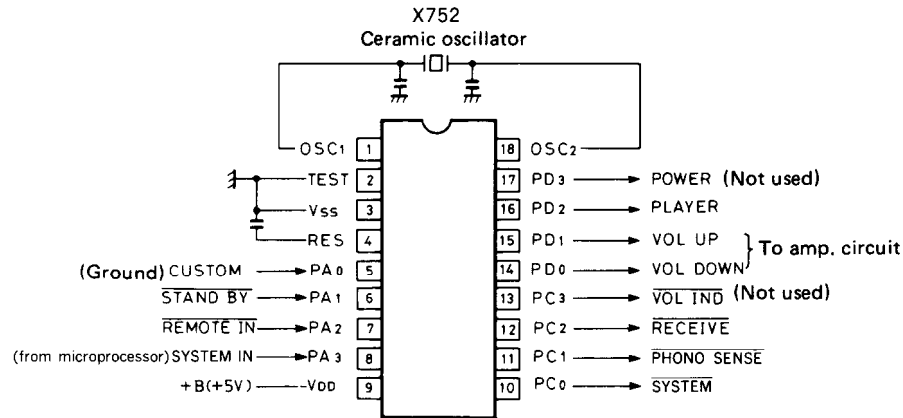
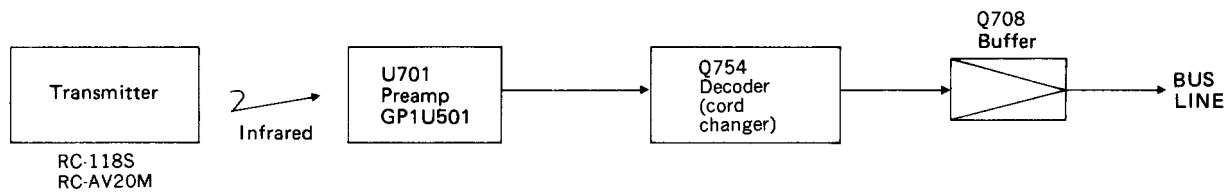

Connection diagram

Terminal No.	Symbol	Terminal	Description
1 18	OSC1 OSC2	OSC	Connect to the 4MHz ceramic oscillator.
2	TEST	TEST	Test terminal. Connect to the ground.
3	Vss	GND	Ground terminal.
4	RES	RES	Reset terminal.
5	PA0	CUSTOM	The custom code for decode is selected at this terminal. For this model, the level is low.
6	PA1	STANDBY	Terminal for STANDBY detection. During low input, only the POWER code is decoded.
7	PA2	REMOTE IN	Signal input terminal from remote control preamp. Active low.
8	PA3	SYSTEM IN	System code input terminal. Active high.
9	V _{DD}	+B(5V)	Power supply terminal.
10	PC0	SYSTEM OUT	Output at this terminal are the custom code remote control code input to REMOTE IN, the system code that has been converted corresponding to the decoded data code.
11	PC1	PH SENS	Phono detection input terminal. Active low.
12	PC2	RECEIVE	This is the display output for remote control reception. Output is low when decoded code is being received.
13	PC3	VOLIND	During output of VOLUME UP/DOWN, a pulse ($\overline{\text{I}}\text{T}\text{I}$; T=250ms) is output.
14	PD0	VOL DOWN	When the volume DOWN code is input, a high pulse of 120ms is output.
15	PD1	VOL UP	When the volume UP code is input, a high pulse of 120ms is output.
16	PD2	PLAYER	Player control output terminal.
17	PD3	POWER	The power code input inverts the L/H. Level is high for power being tuned ON.

LM7001 (PLL SYNTHESIZER AND CONTROLLER)

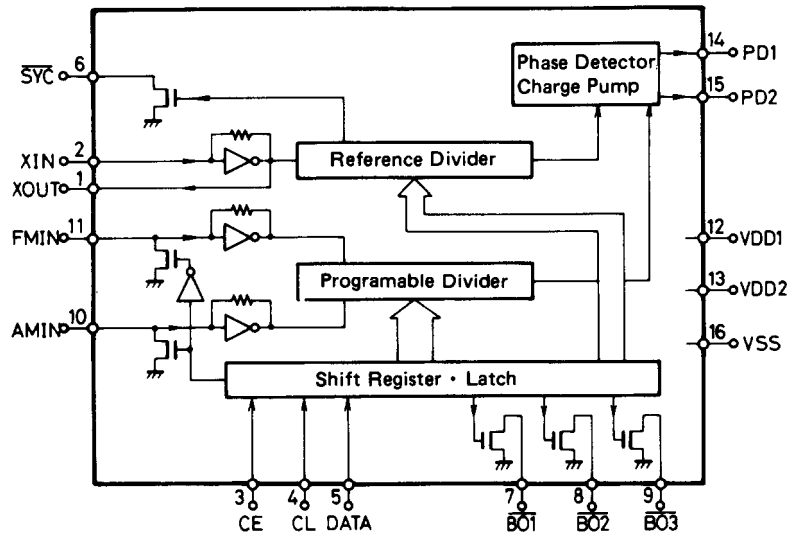

Pin No.	Terminal	Description
1	XOUT	Connect to the 7.2 MHz crystal oscillator.
2	XIN	
3	CE	Chip enable terminal. Connect to the PLL terminal of LC6538D-3838.
4	CL	Serial clock input terminal. Connect to the CL terminal of LC6538D-3838.
5	DATA	Serial data input terminal. Connect to the DATA terminal of LC6538D-3838.
6	$\overline{\text{SYN}}$	Not used.
7	$\overline{\text{BO1}}$	Antenna selector output terminal. Antenna B.
8	$\overline{\text{BO2}}$	FM auto tuning output terminal. "L" when FM. Auto tuning at low level at high level.
9	$\overline{\text{BO3}}$	AM band control signal output terminal. AM band at low level.
10	AMIN	AM local oscillator input terminal.
11	FMIN	FM local oscillator terminal.
12	VDD1	Power supply terminal for back-up.
13	VDD2	Power supply terminal.
14	PD1	Charge pump output of the phase detector which constitutes the PLL. High level is output when the divided local oscillator frequency is high than the reference frequency.
15	PD2	In the opposite case, low level is output. Floating occurs when the frequencies matched. The output is applied to the variable capacitor diode in the local oscillator through the low pass filters.
16	VSS	Ground terminal.

FIP15AMW26 (FLUORESCENT INDICATOR TUBE)

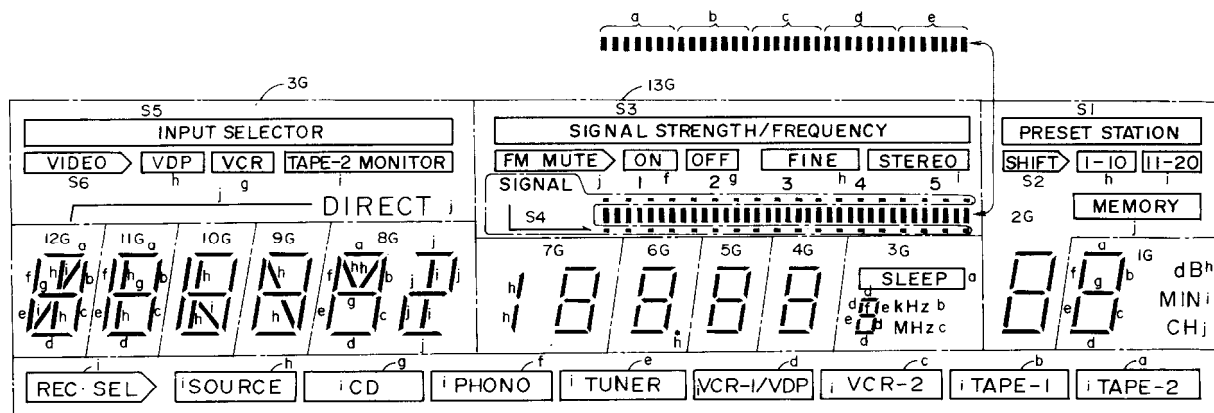

Terminal No.	1	2	3	4	5	6	7	8	9	10	11	12	13	14	15	16	17
Electrode	F	NP	S1	S2	S3	S4	S5	S6	j	i	NP	h	NP	g	f	NP	e

(Left)

Terminal No.	18	19	20	21	22	23	24	25	26	27	28	29	30	31	32	33	34
Electrode	d	c	b	a	NP	NP	NP	14G	NP	13G	12G	11G	10G	9G	8G	7G	6G

Terminal No.	35	36	37	38	39	40	41	42	43
Electrode	5G	4G	3G	2G	1G	NP	NP	NP	F

F : Filament
 G : Grid
 NP: No pin
 a~j/1G~14G: Anode

(Right)

Segment	Digit	D14	D13	D12	D11	D10	D9	D8	D7	D6	D5	D4	D3	D2	D1
Sa	TAPE-2	1th □	a	a	a	a	a	a	a	a	a	a	SLEEP	a	a
Sb	TAPE-1	2nd □	b	b	b	b	b	b	b	b	b	b	kHz	b	b
Sc	VCR	3rd □	c	c	c	c	c	c	c	c	c	c	MHz	c	c
Sd	VDP	4th □	d	d	d	d	d	d	d	d	d	d	┌ └	d	d
Se	TUNER	5th □	e	e	e	e	e	e	e	e	e	e	┌ └	e	e
Sf	PHONO	ON	f	f	f	f	f	f	f	f	f	f	—	f	f
Sg	CD	OFF	g	g	g	g	g	g	g	g	g	g	VCR	g	g
Sh	SOURCE	FINE					\	∨					VDP	1-10(A)	dB
Si	REC SEL	STEREO	/				\						TAPE-2	11-20(B)	MIN
Sj		FM MUTE						┌ └					DIRECT	MEMORY	CH

ADJUSTMENT PROCEDURES

Preparation

• Input

FM mono: 1kHz, 75kHz devi., 60dB/μV

FM stereo: 1kHz, L+R 67.5kHz devi.: Pilot signal 19kHz
7.5kHz devi.

AM: 400Hz, 30% mod.,

• Output

Connect the non-inductive type resistor of 8 ohms to the speaker terminal A of left and right channels unless otherwise noted.

• Standard knob position

TAPE MONITOR	SOURCE
VOLUME	Maximum
BASS/TREBLE/BALANCE	Center
MODE	STEREO
SPEAKER	A
SIMULATED STEREO	OFF
DYNAMIC, BASS EXPANDER	OFF
SELECTIVE TONE CONTROL	OFF
MUTING/LOUDNESS	OFF
CARTRIDGE SELECTOR	MM
REC SELECTOR	SOURCE

Amplifier section

1. Idling current adjustment

Connect the DC voltmeter to the terminals IID and VCT on the power amplifier pc board.

Adjust the semi-fixed resistors R531 and R532 so that the indication of voltmeter is 15 ± 2 mV.

Notes: VOLUME Maximum, Open load,
Adjust after switching on for 15 minutes.



2. Check of operation of protection circuit.

1) Check of operation of protection relay.

(1) Confirm that the relay turns ON approximately 5 seconds after the power switch is turned ON.

(2) The relay should turn OFF approximately 0.5 seconds after the power switch is turned OFF.

2) Check of DC detection

(1) Turn the power on with no load.

(2) After the speaker relay turns ON, apply DC1~1.5V to the CD input terminals. Confirm that the relay turns OFF.

(3) Confirm that operation is the same as (2) above when an input of DC-1~-1.5V is applied.

Note) Under no circumstances connect a load or short the speaker terminals when performing the above test.

FM section

Item	Step	Connection of instrument	FM SG output	Stereo modulator output	Turning dial setting	Output indicator	Adjustment	Adjust for	Remarks
FM IF	1		99.1MHz	-	99.1MHz	DC millivolt meter	L101	0V ± 20mV	Muting switch: OFF
	2	Fig. 1	1kHz, 75kHz devi. 65dB (60dB)	-		DC voltmeter	IF on the front end	Maximum	Repeat the steps 1 and 3 until no further adjustment is necessary
	3					Distortion analyzer	L102	Minimum	
VCO		Fig. 2	99.1MHz 1kHz, 75kHz devi. 65dB (60dB)	-	99.1MHz	Frequency counter	R201	76kHz ± 40Hz	
Stereo Distortion		Fig. 3	99.1MHz 65dB (60dB) Ext. modulation	L or Reh. 1kHz	99.1MHz	Distortion analyzer	IF on the front end	Minimum	Don't turn more than ± 180°
		Fig. 3	99.1MHz 65dB (60dB) Ext. modulation	Lch. 1kHz	99.1MHz	Rech. AC voltmeter	R202	Minimum	Maximum and same separation
Stereo Separation	1		99.1MHz 19.2dB (14dB) Ext. modulation	-	99.1MHz	Rech. AC voltmeter		Light on	
	2	Fig. 3	99.1MHz 18.2dB (13dB) Ext. modulation	Rech. 1kHz	99.1MHz	Rech. AC voltmeter		Light off	Muting switch: ON
Muting level		Fig. 3	99.1MHz 45.2dB (40dB) 1kHz, 75kHz devi.	-	99.1MHz	Auto indicator	R101	Light on	
Signal indicator level		Fig. 3	99.1MHz 45.2dB (40dB) 1kHz, 75kHz devi.	-	99.1MHz	5th Signal indicator	R102	Light on	

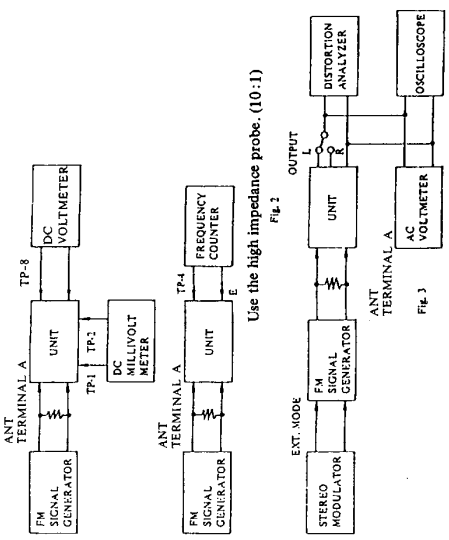

Use the high impedance probe. (10:1)

AM section

Step	AM SG output	Tuned frequency	Output indicator	Adjustment point	Adjust for
1		530kHz (531kHz)	Digital DC voltmeter	OSC on RF block	1.3V ± 0.1V
2	600kHz(603kHz) 400Hz 30% mod. 60dB/m	600kHz (603kHz)	AC voltmeter	RF on RF block	Maximum
3	1000kHz (999kHz) 400Hz 30% mod. 60dB/m	1000kHz (999kHz)	AC voltmeter	L152	Maximum

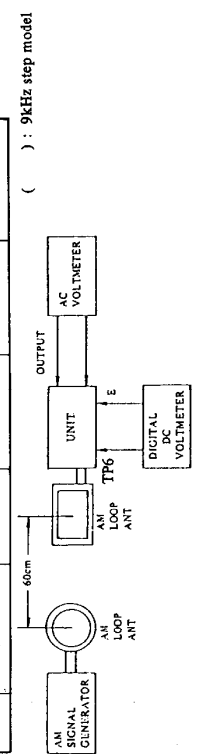

Reference specifications
 FM Tuned voltage (TP-6)
 87.5MHz 1.5±0.5V
 108.0MHz 8.0±0.5V
 Signal meter voltage (TP-8)
 98MHz 60dBμ more than 4V
 Auto stop level AM: Less than 62dB/m
 FM: 14±3dBμ
 Hi-blend switching level 33±5dBμ
 NR switching level 17±5dBμ
 DX/LOCAL switching level 60±8dBμ
 AM Tuned voltage (TP-6)
 530kHz 1.3±0.5V
 1620kHz 8.0±0.5V

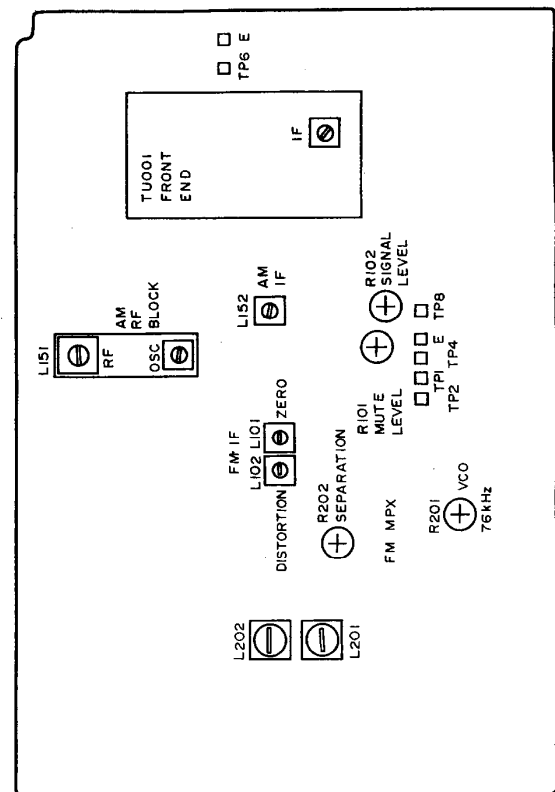

SCHEMATIC DIAGRAM

NARF-3460-2

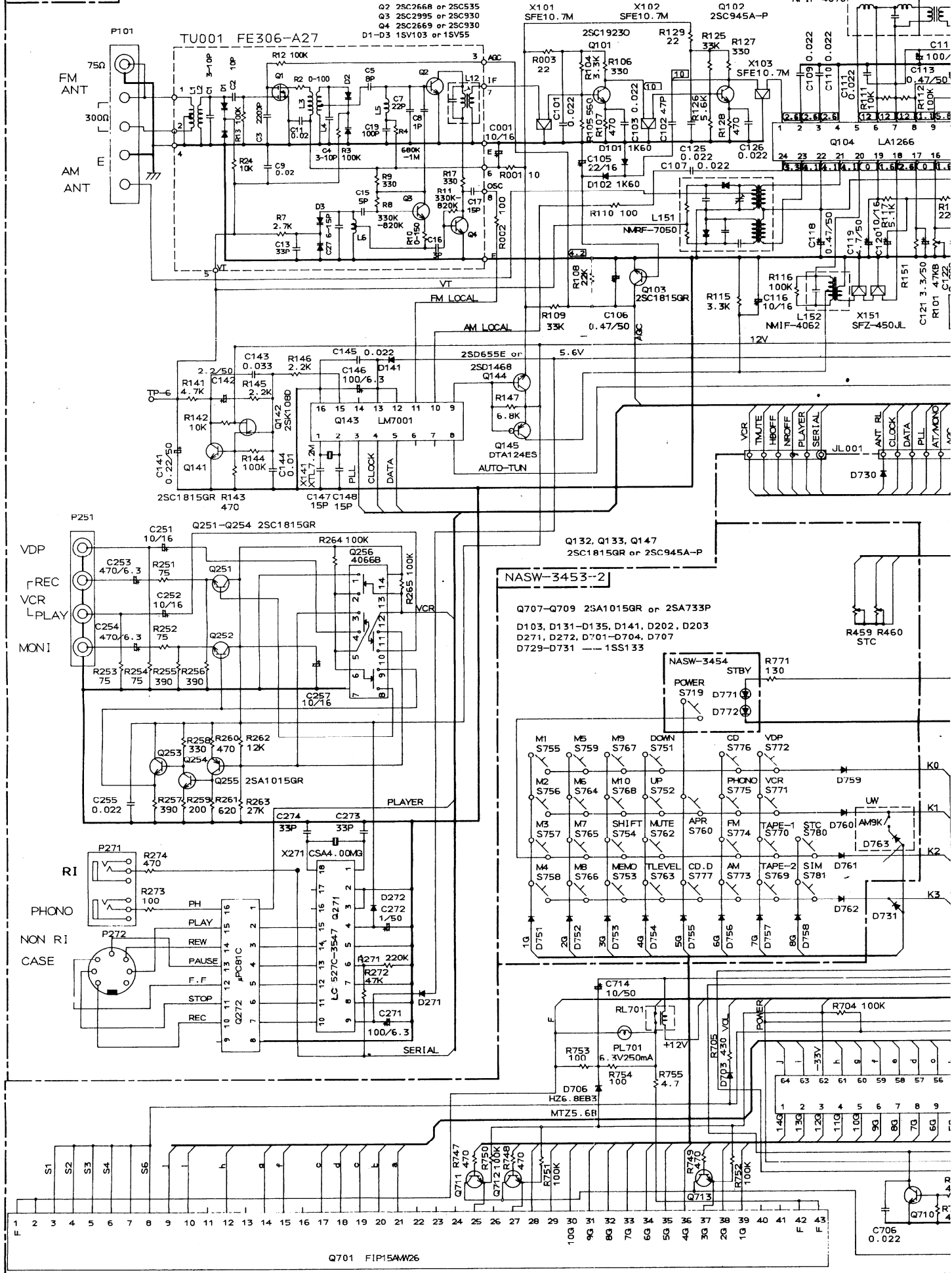

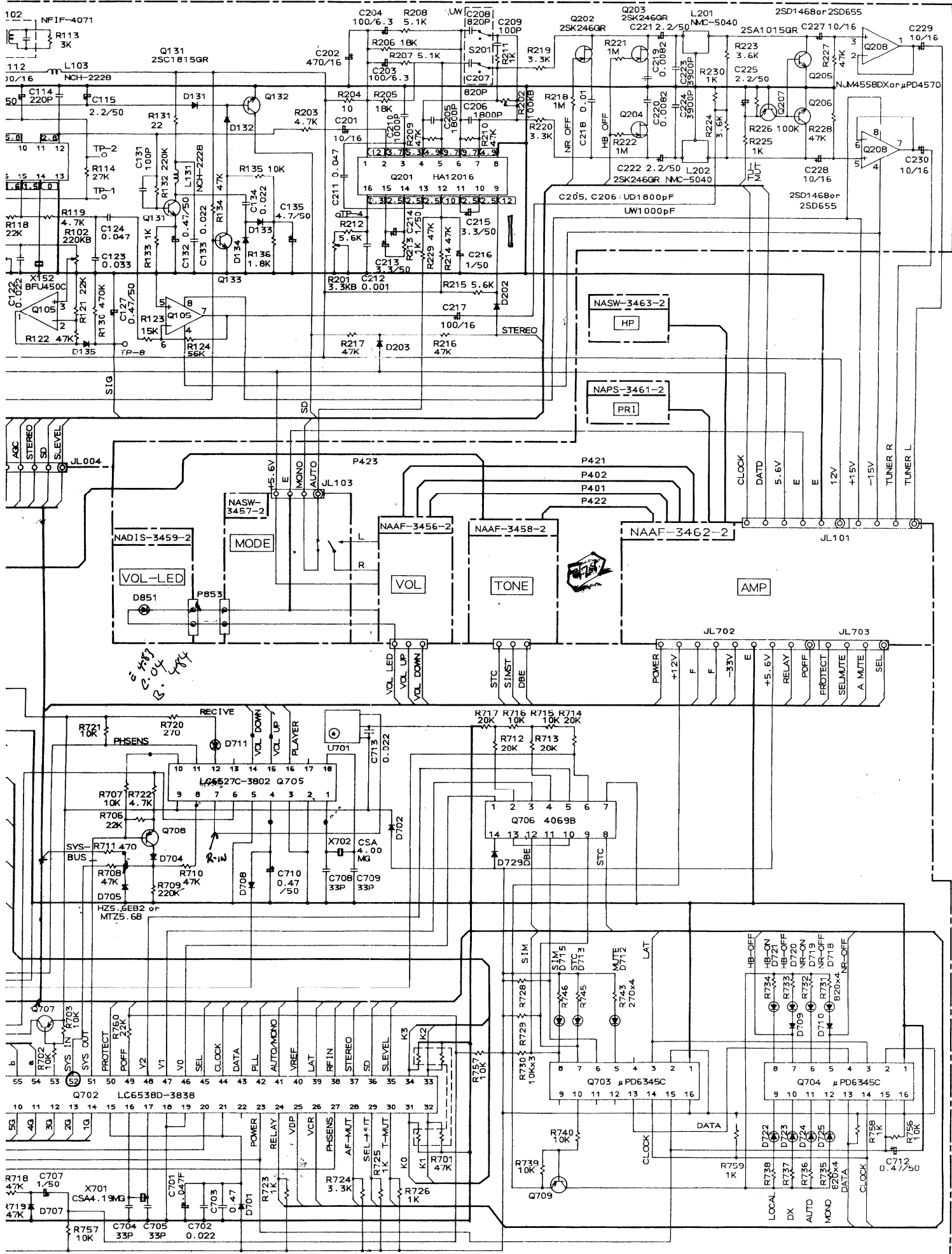

SCHEMATIC DIAGRAM

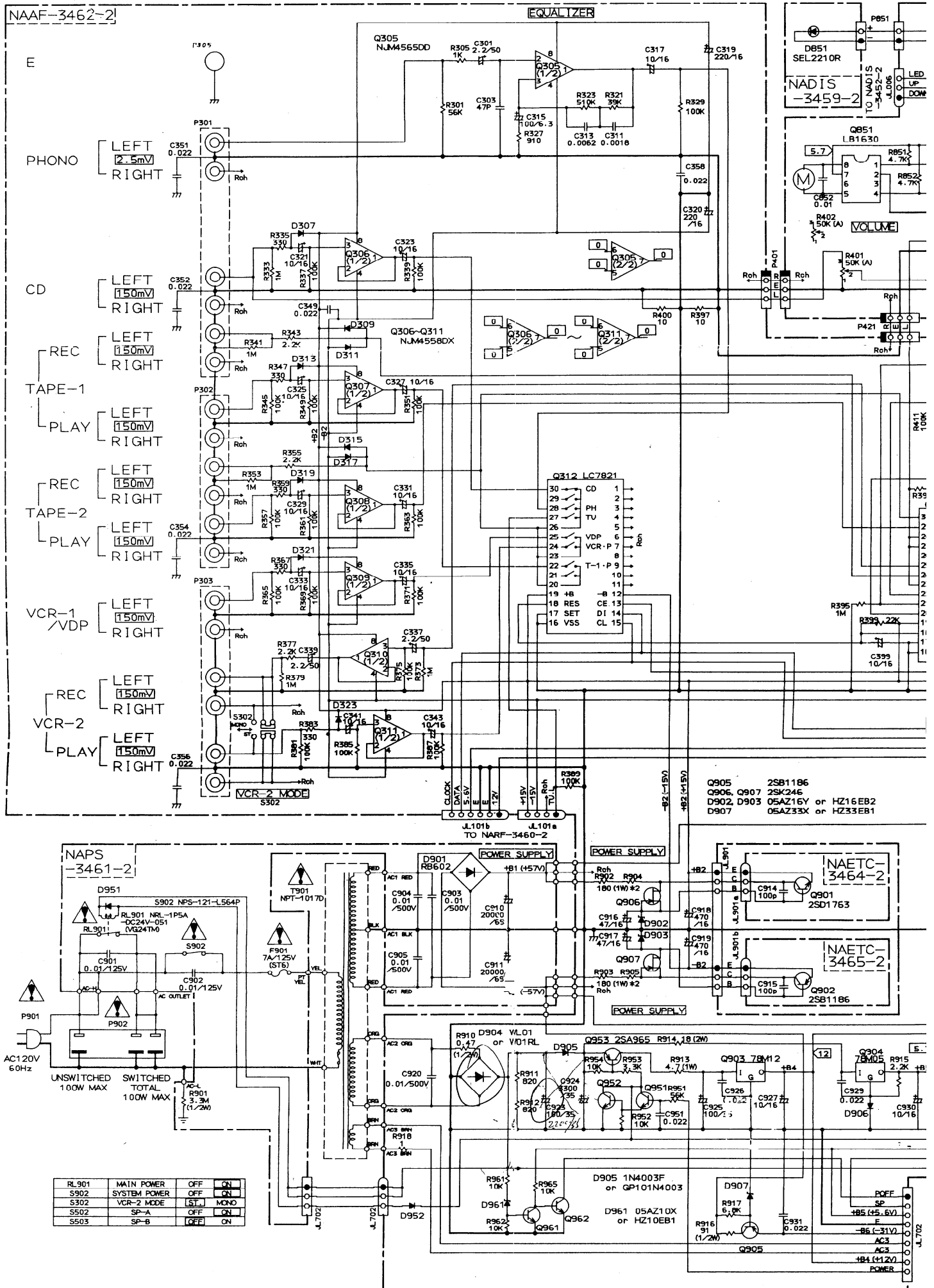

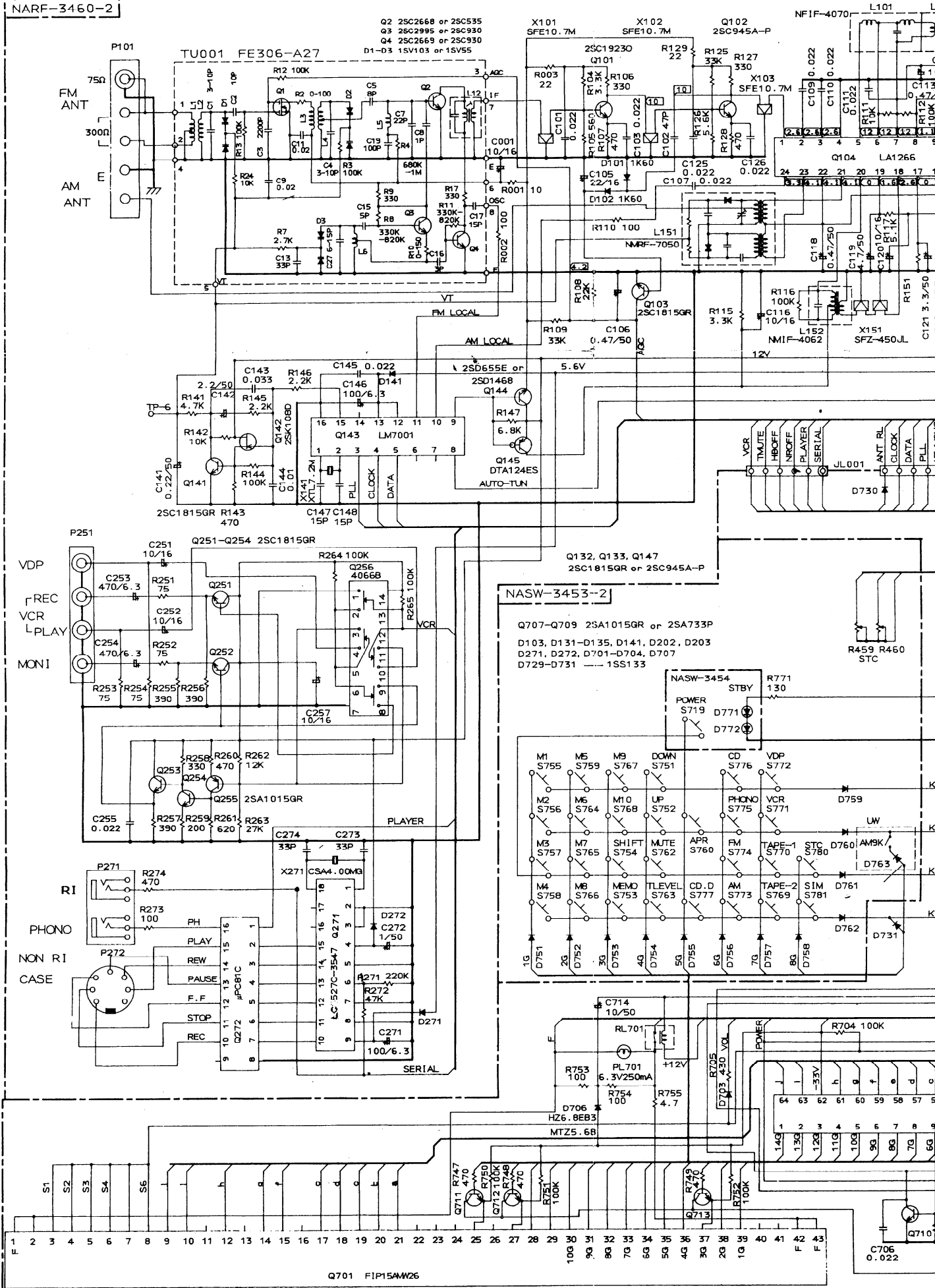

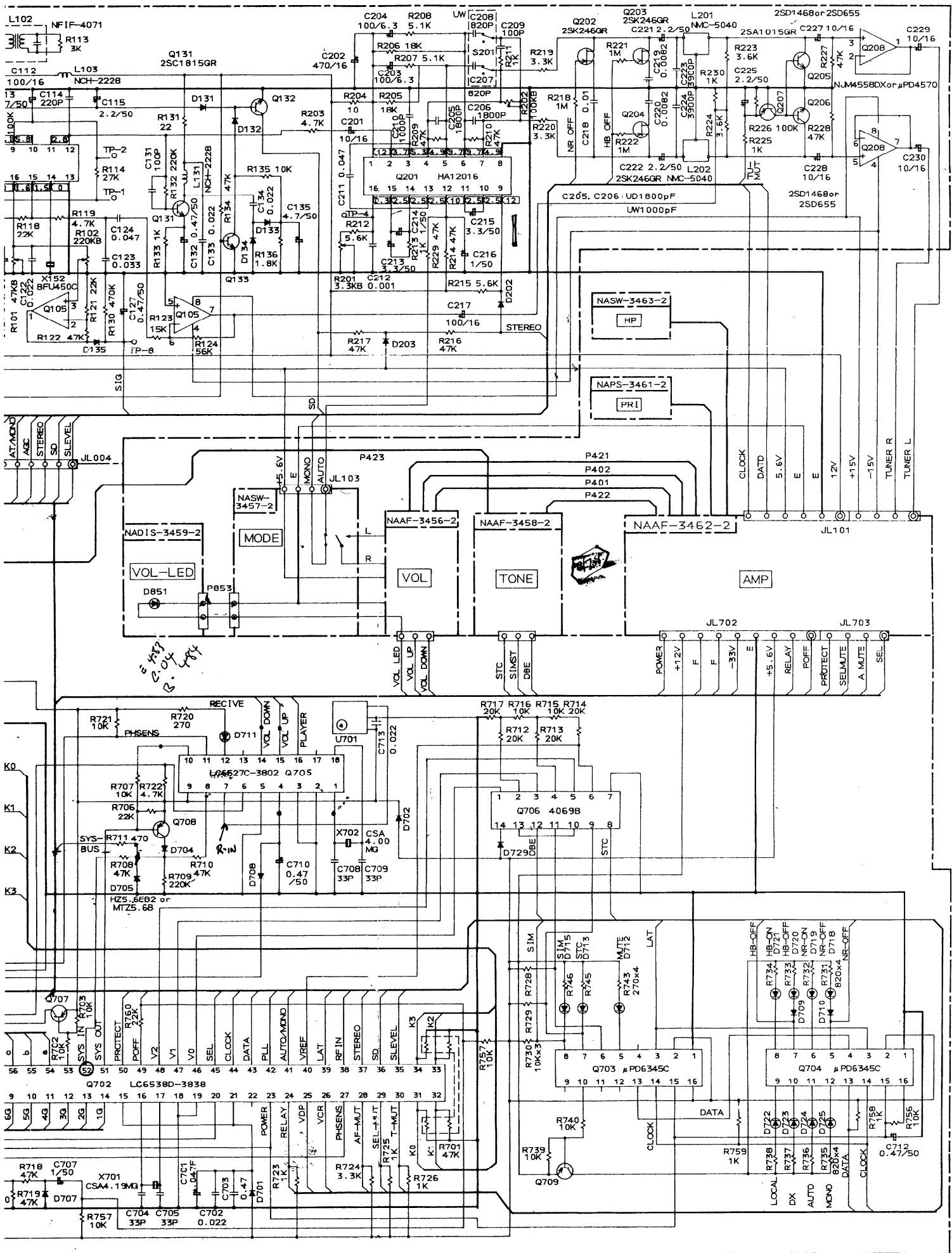

PRINTED CIRCUIT BOARD- PARTS LIST

DISPLAY CIRCUIT PC BOARD (NADIS-3452-2)

CIRCUIT NO.	PART NO.	DESCRIPTION
		Remote sensor
U701	24130001	GPIU501S
		Lamp
Q700	210064A	PL6. 3V, 250mA
		Fluorescent tube
Q701	212069	FIP15AMW26
		ICs
Q702	22240210	LC6538D-3838
Q703, Q704	22240211	μ PD6345C
Q705	22240194	LC6527C-3802
Q706	222840692	4069UB
		Transistors
Q707-Q709	2211455 or 2210803	2SA1015-GR or 2SA733-P
Q710-Q713	2211255 or 2210746	2SC1815-GR or 2SC945A-P

CIRCUIT NO.	PART NO.	DESCRIPTION
		Diodes
D701-D704	223163	1SS133
D705	224150562, 224650562 or 224450562	05AZ5. 6Y, HZ5. 6EB2 or MTZ5. 6B
D706	224150752, 224650752 or 224450752	05AZ7. 5Y, HZ7. 5EB2 or MTZ7. 5B
D707-D710	223163	1SS133
D729-D731	223163	1SS133
		L. E. Ds
D711, D712	225141	SEL2213C
D713, D715	225137CG,	SEL2413E-CG,
D718, D720	225137DG or	SEL2413E-DG or
D722, D724	225137DY	SEL2413E-DY
D719, D721	225142	SEL2913K
D723, D725	225142	SEL2913K
		OSC elements
X701	3010133	CSA4. 19MG, Ceramic
X702	3010099	CSA4. 00MG, Ceramic
		Capacitors
C701	3000051	0.047F, 5. 5V, Super for memory prevention
C703	375524744	0.47 μ F \pm 5%, 50V, Plastic(MMT)
C707	353780109	1 μ F, 50V, Elect.
C710, C712	353784799	0.47 μ F, 50V, Elect.
C714	353781009	10 μ F, 50V, Elect.
		Resistor
R701	49163473404	47kohm \times 4, 1/10W, Network
		Relay
RL701	25065298	NRL-1P1A-DC12-40
		Holder
	27190682	LED

OPERATION SWITCH PC BOARD (NASW-3453-2/2A)

CIRCUIT NO.	PART NO.	DESCRIPTION
		Diodes
D751-D762	223163	1SS133
D763	223163	1SS133<W>
		Variable resistor
R459	6112008	N30LGL100KRD5Z
		Push switches
S751-S777	25035548	NPS-111-S510
S780, S781	25035548	NPS-111-S510

STAND-BY SWITCH PC BOARD (NASW-3454-2)

CIRCUIT NO.	PART NO.	DESCRIPTION
D771, D772	225142	SEL2913K, L. E. Ds
S771	25035548	NPS-111-S510, Power switch
	27190454A	Holder, LED

AM BAND STEP SELECTOR PC BOARD (NASW-3455-2)

<Only Worldwide model>

CIRCUIT NO.	PART NO.	DESCRIPTION
S775	25065267	NSS-22109, Band step switch

DE-EMPHASIS SWITCH PC BOARD (NASW-3467-2)

<Only Worldwide model>

CIRCUIT NO.	PART NO.	DESCRIPTION
	25065267	NSS-22109, De-emphasis switch

NOTE : <D> : Only 120V model
<W> : Only Worldwide model

PRINTED CIRCUIT BOARD-PARTS LIST

FM/AM TUNER PC BOARD (NARF-3460-2/2A)

CIRCUIT NO.	PART NO.	DESCRIPTION
	Front end	
TU001	240080	FE306-A27
	ICs	
Q104	22240214	LA1266A
Q105	222502 or 22240050	NJM4558DX or μ PC4570C
Q143	22240090	LM7001
Q201	222593	HA12016
Q208	222502 or 22240050	NJM4558DX or μ PC4570C
Q256	222840661	4066B
Q271	22240145	LC6527C-3547
Q272	222807	μ PA81C
	Transistors	
Q101	2211723	2SC1923-O
Q102	2210746	2SC945A-P
Q103, Q131	2211255	2SC1815-GR
Q132, Q133	2211255 or	2SC1815-GR or
Q147	2210746	2SC945A-P
Q141	2211255	2SC1815-GR
Q142	2212294	2SK108-D
Q144	2211705,	2SD655-E,
Q205, Q206	2211706 or 2212794	2SD655-F or 2SD1468-R
Q145	2212600	DTA124ES
Q202-Q204	2211945	2SK246-GR
Q207	2211455 or 2210803	2SA1015-GR or 2SA733-P
Q251-Q254	2211255	2SC1815-GR
Q255	2211455	2SA1015-GR
	Diodes	
D101, D102	223132	1K60
D131-D135	223163	1SS133
D141	223163	1SS133
D202, D203	223163	1SS133
D271, D272	223163	1SS133
	Transformers	
L101	233396	NFIF-4070
L102	233397	NFIF-4071
L152	232139	NMIF-4062
	Coils	
L103	233400K033	NCH-2228
L131	231081	NCH-2129
L201, L202	233294	NMC-5040
	RF block	
L151	232148	NMRF-7050
	Ceramic filters	
X101, X102	3010137	SFE10. 7MMK
X103	3010006	SFE10. 7MA8
X151	3010123	SFZ450JL
X152	3010076	BFU450C
	OSC element	
X141	3010141	XTL7. 2M, X'tal
X271	3010099	CSA4. 00MG, Ceramic
	Capacitors	
C001	354741009	10 μ F, 16V, Elect.
C105	354742209	22 μ F, 16V, Elect.
C106, C113	354784799	0.47 μ F, 50V, Elect.
C112	354741019	100 μ F, 16V, Elect.
C115	354780229	2.2 μ F, 50V, Elect.
C116	354741009	10 μ F, 16V, Elect.

CIRCUIT NO.	PART NO.	DESCRIPTION
	Capacitors	
C118	354784799	0.47 μ F, 50V, Elect.
C119	354780479	4.7 μ F, 50V, Elect.
C120	354741009	10 μ F, 16V, Elect.
C121	354780339	3.3 μ F, 50V, Elect.
C123	371123334	0.033 μ F \pm 5%, 50V, Mylar
C124	371124734	0.047 μ F \pm 5%, 50V, Mylar
C127, C132	354784799	0.47 μ F, 50V, Elect.
C135	354780479	4.7 μ F, 50V, Elect.
C141	354782299	0.22 μ F, 50V, Elect.
C142	354780229	2.2 μ F, 50V, Elect.
C143	371123334	0.033 μ F \pm 5%, 50V, Mylar
C144	371121034	0.01 μ F \pm 5%, 50V, Mylar
C146	354721019	100 μ F, 6.3V, Elect.
C201	354741009	10 μ F, 16V, Elect.
C202	354744719	470 μ F, 16V, Elect.
C203, C204	354721019	100 μ F, 6.3V, Elect.
C205, C206	371121824	1800pF \pm 5%, 50V, Mylar<D>
	371121024	1000pF \pm 5%, 50V, Mylar<W>
C207, C208	370138214	820pF \pm 5%, 100V, APS<W>
C211	371124734	0.047 μ F \pm 5%, 50V, Mylar
C212	370131024	1000pF \pm 5%, 100V, APS
C213, C215	354780339	3.3 μ F, 50V, Elect.
C214, C216	354780109	1 μ F, 50V, Elect.
C217	354741019	100 μ F, 16V, Elect.
C218	371121034	0.01 μ F \pm 5%, 50V, Mylar
C219, C220	371128224	8200pF \pm 5%, 50V, Mylar
C221, C222	354780229	2.2 μ F, 50V, Elect.
C223, C224	371123924	3900pF \pm 5%, 50V, Mylar
C225	354780229	2.2 μ F, 50V, Elect.
C227-C230	354741009	10 μ F, 16V, Elect.
C251, C252	354741009	10 μ F, 16V, Elect.
C253, C254	354724719	470 μ F, 6.3V, Elect.
C257	354741009	10 μ F, 16V, Elect.
C271	354721019	100 μ F, 6.3V, Elect.
C272	354780109	1 μ F, 50V, Elect.
	Resistors	
R101	5210068	N06HR47KBD, Semi-fixed, FM mute level
R102	5210072	N06HR220KBD, Semi-fixed, FM signal level
R201	5210061	N06HR3.3KBD, Semi-fixed, VCO
R202	5210070	N06HR100KBD, Semi-fixed, Separation
	Terminals	
P101	25060091	NTM-3PDMN32, Antenna
P251	25045216	NPJ-4PDBL94, Output VIDEO
P271	25045172	HSJ1003-01-020, Phono/RI
P272	25050294	NSCT-8P-121, Tape DIN
	Sockets	
JL103	25050268	NSCT-4P-96
JL001	25050270	NSCT-6P-98
JL004	25050272	NSCT-8P-100
JL101	25050274	NSCT-10P-102
	Bracket	
	27141059	Ground

NOTE : <D> : Only 120V model
<W> : Only Worldwide model

PRINTED CIRCUIT BOARD-PARTS LIST

PRE. AND POWER AMPLIFIER PC BOARD (NAAF-3462-2)

CIRCUIT NO.	PART NO.	DESCRIPTION
Transistors		
Q491-Q494	2212285 or 2212286	2SC2878-A or 2SC2878-B
Q501, Q502	2211371 or 2211372	2SC2259-O-001 or 2SC2259-O-002
Q503-Q506	2211455	2SA1015-GR
Q507, Q508	2211732 or 2211733	2SC1845-F or 2SC1845-E
Q509, Q510	2211255	2SC1815-GR
Q511, Q512	2211353 or 2211354	2SA949-O or 2SA949-Y
Q513, Q514	2211633 or 2211634	2SC2229-O or 2SC2229-Y
Q515, Q516	2211255	2SC1815-GR
Q517, Q518	2211633 or 2211634	2SC2229-O or 2SC2229-Y
Q519, Q520	2211353 or 2211354	2SA949-O or 2SA949-Y
Q521, Q522	2201643 or 2201644	2SC3298-O or 2SC3298-Y
Q523, Q524	2201633 or 2201634	2SA1306-O or 2SA1306-Y
Q525, Q526	2201703,	2SC3855-O, #
Q529, Q530	2201704 or 2201706	2SC3855-Y or 2SC3855-P
Q527, Q528	2201693,	2SA1491-O, #
Q531, Q532	2201694 or 2201696	2SA1491-Y or 2SA1491-P
NOTE : Replacement for transistor of mark #, if necessary, must be made from the same beta group (HFE) as the original type.		
	Ex.	2SC3855-O 2SA1491-O
		└──────────┘
		Same beta group
Q571, Q572	2211633 or 2211634	2SC2229-O or 2SC2229-Y
Q573, Q574	2211732 or 2211733	2SC1845-F or 2SC1845-E
Q575	2211792 or 2211793	2SA992-F or 2SA992-E
Q691, Q692	2212600	DTA124ES
Q905	2201934, 2201935 or 2201936	2SB1186-D, 2SB1186-E or 2SB1186-F
Q906, Q907	2211945	2SK246-GR
Q951, Q952	2211255 or 2210746	2SC1815-GR or 2SC945A-P
Q953	2211643 or 2211644	2SA965-O or 2SA965-Y
Q954	2211792 or 2211793	2SA992-F or 2SA992-E
Q961, Q962	2211255 or 2210746	2SC1815-GR or 2SC945A-P
Q971-Q973	2211255	2SC1815-GR
ICs		
Q306-Q311	222502	NJM4558DX
Q312	22240079	LC7821
Q314	22240081	LC7822
Q305, Q401	22240191	NJM4565DD
Q903	222780122NEC	78M12
Q904	222780052NEC	78M05
Diodes		
D301-D302	223163	1SS133
D307-D324	223163	1SS133
D491-D494	223163	1SS133

CIRCUIT NO.	PART NO.	DESCRIPTION
Diodes		
D501-D506	223163	1SS133
D507, D508	4000120	KB265
D902, D903	224151602 or 224651602	05AZ16Y or HZ16EB2
D904	223862 or 223890	WL01 or W01RL
D905	223880 or 223896	GP101N4003 or 1N4003F
D906	223163	1SS133
D907	224153301 or 224653301	05Z33X or HZ33EB1
D952, D953	223163	1SS133
D961	224151001 or 224651001	05AZ10X or HZ10EB1
D971-D973	223163	1SS133
Capacitors		
C301, C302	354780229	2.2 μ F, 50V, Elect.
C311, C312	371121824	1800pF \pm 5%, 50V, Mylar
C313, C314	371126224	6200pF \pm 5%, 50V, Mylar
C315, C316	354721019	100 μ F, 6.3V, Elect.
C317, C318	354741009	10 μ F, 16V, Elect.
C319, C320	354742219	220 μ F, 16V, Elect.
C321-C336	354741009	10 μ F, 16V, Elect.
C337-C340	354780229	2.2 μ F, 50V, Elect.
C341-C348	354741009	10 μ F, 16V, Elect.
C399	354741009	10 μ F, 16V, Elect.
C401, C402	354780229	2.2 μ F, 50V, Elect.
C405, C406	354721019	100 μ F, 6.3V, Elect.
C407, C408	354741009	10 μ F, 16V, Elect.
C501, C502	354741009	10 μ F, 16V, Elect.
C507, C508	354722219	220 μ F, 6.3V, Elect.
C513, C514	354780229	2.2 μ F, 50V, Elect.
C525-C528	371124734	0.047 μ F \pm 5%, 50V, Mylar
C573	354722219	220 μ F, 6.3V, Elect.
C574	354790479	4.7 μ F, 100V, Elect.
C591, C592	354790479	4.7 μ F, 100V, Elect.
C691, C692	354741009	10 μ F, 16V, Elect.
C916, C917	354744709	47 μ F, 16V, Elect.
C918, C919	354744719	470 μ F, 16V, Elect.
C920	335251039	0.01 μ F, 500V, Ceramic
C923	354761019	100 μ F, 35V, Elect.
C924	354763329	3300 μ F, 35V, Elect.
C925	354761019	100 μ F, 35V, Elect.
C927, C930	354741009	10 μ F, 16V, Elect.
Resistors		
R525, R526	442522704	27ohm, 1/2W, Metal oxide film
R529, R530	442529104	91ohm, 1/2W, Metal oxide film
R531, R532	5210062	N06HR4.7KBD, Semi-fixed, Idling
R537, R538	442521024	1kohm, 1/2W, Metal oxide film
R539, R540	442521014	100ohm, 1/2W, Metal oxide film
R541-R548	442520224	2.2ohm, 1/2W, Metal oxide film
R549-R552	441620104	1ohm, 1W, Metal oxide film
R553-R560	4000063 or 4500009	0.47ohm, 2W, Metal plate
R561, R562	441520474	4.7ohm, 1/2W, Metal oxide film
R563, R564	441720824	8.2ohm, 2W, Metal oxide film
R567-R570	442521014	100ohm, 1/2W, Metal oxide film
R591, R592	442520224	2.2ohm, 1/2W, Metal oxide film
R902-R905	441621814	180ohm, 1W, Metal oxide film
R910	442524794	0.47ohm, 1/2W, Metal oxide film
R913	441620474	4.7ohm, 1W, Metal oxide film
R914	441721804	18ohm, 2W, Metal oxide film
R916	442529104	91ohm, 1/2W, Metal oxide film

CIRCUIT NO.	PART NO.	DESCRIPTION	CIRCUIT NO.	PART NO.	DESCRIPTION
L501, L502	231134	S-0.8E	P422a	25055133	NPLG-3P117
S302	25065286	NSS-22112, Mode VCR	P421	2000931	NSAS-6P884
RL501	25065342	NRL-2P1.25A-DC24-048, Head-phone	JL421	25050267	NSCT-3P95
RL502, RL503	25065360	NRL-2P7A-DC24V-052, Speaker	JL702	25050273	NSCT-9P101
P301	25045252	NPJ-6PDBL-124	JL703	25050268	NSCT-4P96
P302, P303	25045213	NPJ-6PDBL-92	JL901	25050270	NSCT-6P98
P304	25045171	NPJ-4PDBL-65	Shield plate		
P501	25060125	NTM-8PDMN058	27150267		
P401a, P402a	25055133	NPLG-3P117	Bracket		
			27141059	GND	
			Radiators		
			27160146	RAD-52	

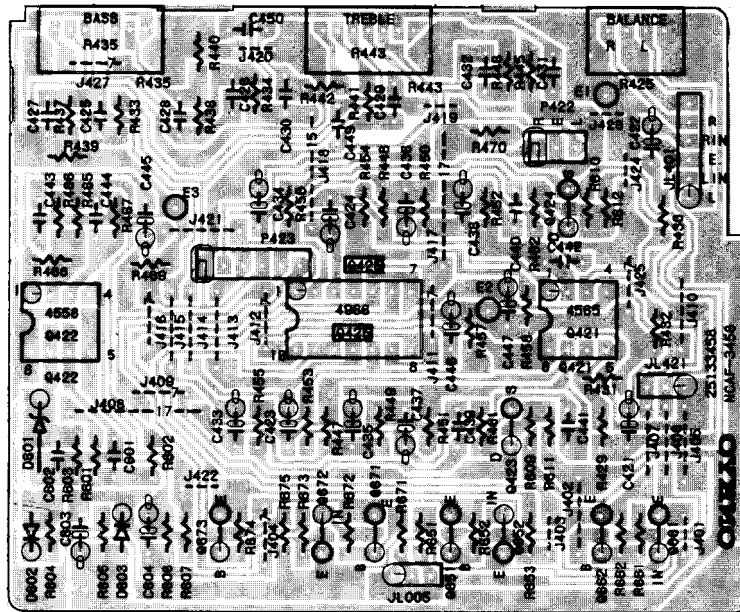

TONE CONTROL CIRCUIT PC BOARD

TONE CONTROL CIRCUIT PC BOARD (NAAF-3458-2)

CIRCUIT NO.	PART NO.	DESCRIPTION	CIRCUIT NO.	PART NO.	DESCRIPTION
					Capacitors
Q421	22240191	NJM4565DD	C435-C438	354781099	0.1 μ F, 50V, Elect.
Q422	222502	NJM4558DX	C439-C442	371121024	1000pF \pm 5%, 50V, Mylar
Q425	22240025	LC4965	C443	371121124	1100pF \pm 5%, 50V, Mylar
			C444	371121234	0.01 μ F \pm 5%, 50V, Mylar
			C445	354741009	10 μ F, 16V, Elect.
Q651, Q671	2211255 or	2SC1815-GR or	C446, C447	354744709	47 μ F, 16V, Elect.
Q673	2210746	2SC945A-P			Resistors
Q652, Q672	2212600	DTA124ES	R425	5104225	N11RGLC250KWT22Z, Variable, Balance
			R435, R436	5104216	N14RLC50KC22Z, Variable, Bass
C421, C422	354780229	2.2 μ F, 50V, Elect.	R443, R444	5104216	N14RLC50KC22Z, Variable, Treble
C423, C424	354741009	10 μ F, 16V, Elect.			Sockets
C425, C426	371123334	0.033 μ F \pm 5%, 50V, Mylar	P422	2000931	NSAS-6P884
C427, C428	352983396	0.33 μ F, 50V, Non-polar elect.	P423	2000558	NSAS-6P514
C429, C430	371124724	4700pF \pm 5%, 50V, Mylar			
C431, C432	371123934	0.039 μ F \pm 5%, 50V, Mylar			
C433, C434	354780229	2.2 μ F, 50V, Elect.			

PRINTED CIRCUIT BOARD VIEW FROM BOTTOM SIDE

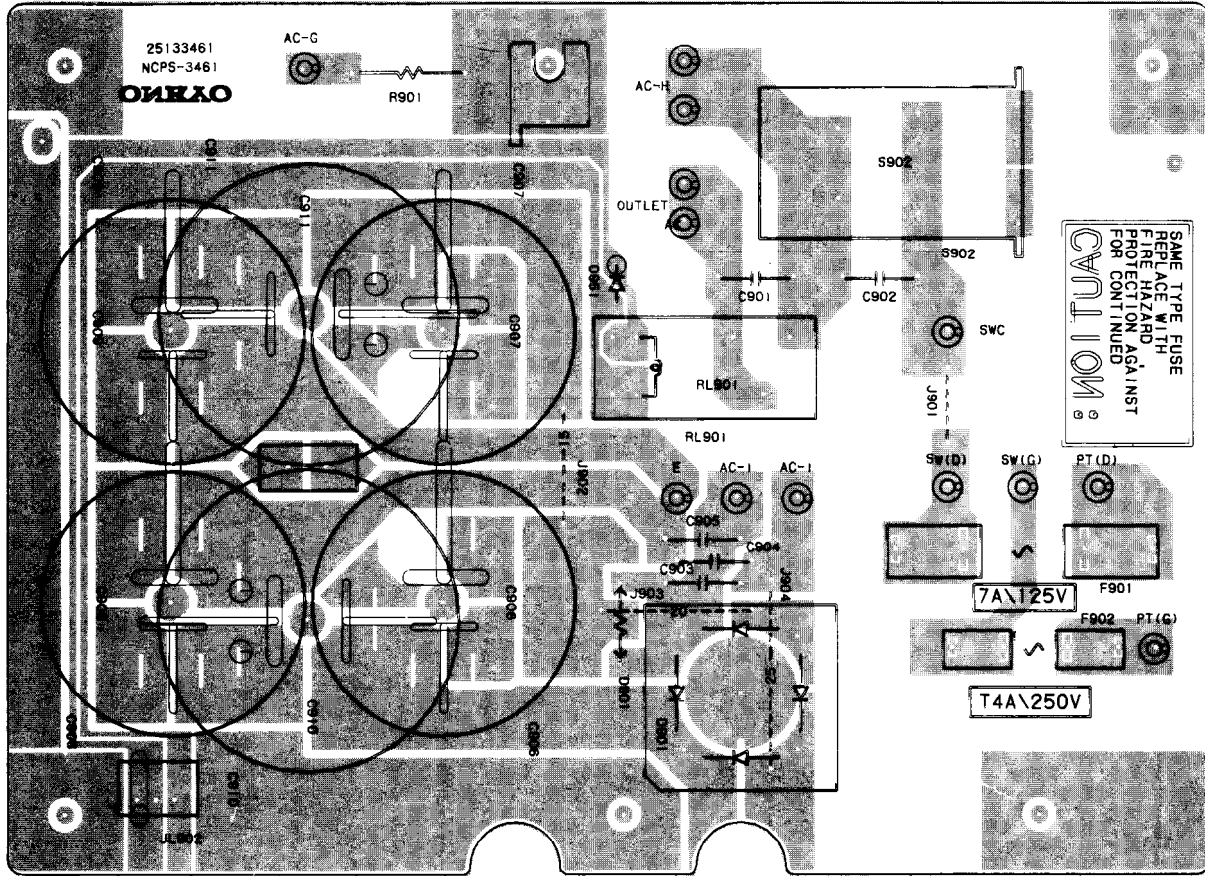

POWER SUPPLY CIRCUIT PC BOARD

PRINTED CIRCUIT BOARD-PARTS LIST

POWER SUPPLY CIRCUIT (NAPS-3461-2)

CIRCUIT NO.	PART NO.	DESCRIPTION
Diodes		
D901	223898	RB602
D951	223163	1SS133
Capacitors		
C901, C902	3500065A	△ DE7150FZ103PAC400V/125V, Capacitor IS
C903-C905	335251039	0.01μF, 500V, Ceramic
C910, C911	3504176	20000 μF, 69V, Elect.
Resistor		
R901	431523355	△ 3.3Mohm, 1/2W, Solid<D>
Relay		
RL901	25065357	NRL-1P5A-DC24V-051<D>
	25065341	NRL-1P15A-DC24V-047<W>
Switch		
S902	25035603	△ NPS-121-L564P
Fuseholders		
F901a	250113	△ SN5051
F902a	25050065	△ YSH403T<W>

CIRCUIT NO.	PART NO.	DESCRIPTION
Fuses		
F901	252052	△ 7A(ST-6)
F902	252077	△ 4A-SE-EAK<W>
Socket		
JL901	25050267	NSCT-3P95
Bracket		
	27141059	GND
Buss		
	27300732	

NOTE : <D> : Only 120V model
 <W> : Only Worldwide model

NOTE : THE COMPONENTS IDENTIFIED BY △ MARK ARE CRITICAL FOR RISK OF FIRE AND ELECTRIC SHOCK. REPLACE ONLY WITH PART NUMBERS SPECIFIED.

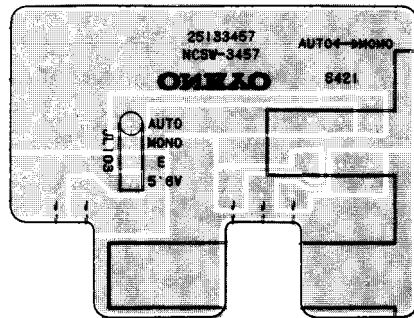

MODE SWITCH PC BOARD

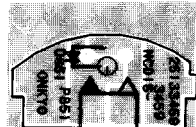

VOLUME INDICATOR PC BOARD

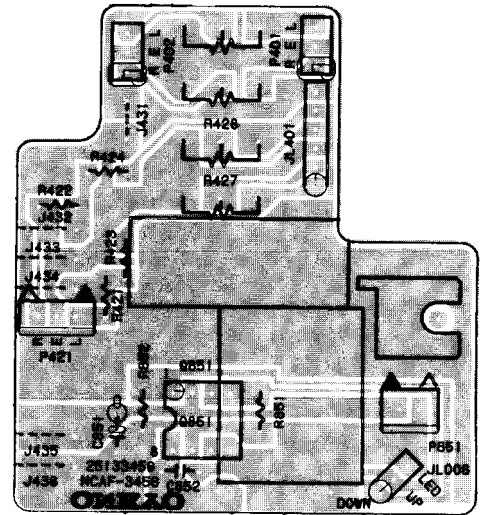

VOLUME PC BOARD

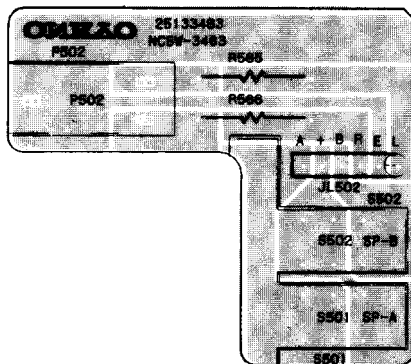

SPEAKER SWITCH PC BOARD

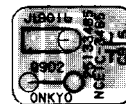

POWER SUPPLY TRANSISTOR PC BOARDS

MODE SWITCH PC BOARD (NASW-3457-2)
 CIRCUIT NO. PART NO. DESCRIPTION
 S421 25035600 NPS-122-L562, Mode switch

VOLUME INDICATOR PC BOARD (NADIS-3459-2)
 CIRCUIT NO. PART NO. DESCRIPTION
 D851 225241 or SEL2210R-C or
 225242 SEL2210R-D, LED
 27190545 Holder

SPEAKER SWITCH PC BOARD (NASW-3463-2)
 CIRCUIT NO. PART NO. DESCRIPTION
 R565, R566 441623914 390ohm, 1W, Metal oxide film
 S501, S502 25035517 NPS-222-L479, Speaker switch
 P502 25045187 HLJ-0541-01-010, Headphone terminal

VOLUME PC BOARD (NAAF-3456-2)
 CIRCUIT NO. PART NO. DESCRIPTION
 Q851 222963 LB1630, IC
 C851 354721019 100 μ F, 6.3V, Elect. capacitor

CIRCUIT NO. PART NO. DESCRIPTION
 R401, R402 5144008 N16RGL50KA30F, Variable resistor
 R427, R428
 P401 2000931 NSAS-6P884, Socket
 P402 2000809 NSAS-6P765, Socket
 P851 2000635A NSAS-4P591, Socket
 P421a 25055133 NPLG-3P117, Plug
 27141059 Bracket GND

POWER SUPPLY TRANSISTOR PC BOARD (NAETC-3464-2)
 CIRCUIT NO. PART NO. DESCRIPTION
 Q901 2201944, 2SD1763-D,
 2201945 or 2SD1763-E or
 2201946 2SD1763-F, Transistor

POWER SUPPLY TRANSISTOR PC BOARD (NAETC-3465-2)
 CIRCUIT NO. PART NO. DESCRIPTION
 Q902 2201934, 2SB1186-D,
 2201935 or 2SB1186-E or
 2201936 2SB1186-F, Transistor