

A

B

C

D

# SCHEMATIC DIAGRAM

TX-88

## -TUNER SECTION-

1

2

3

4

5

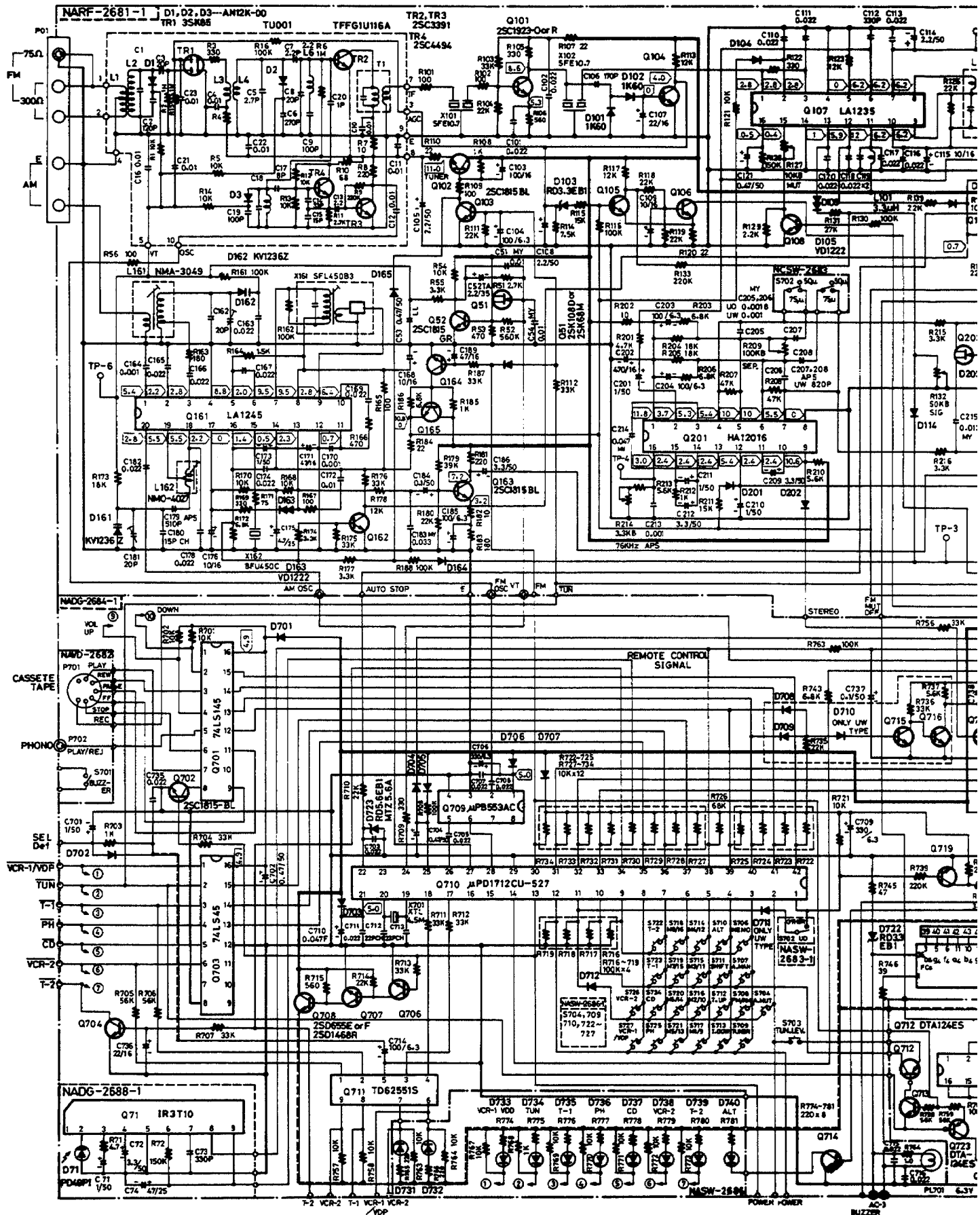

TX-88

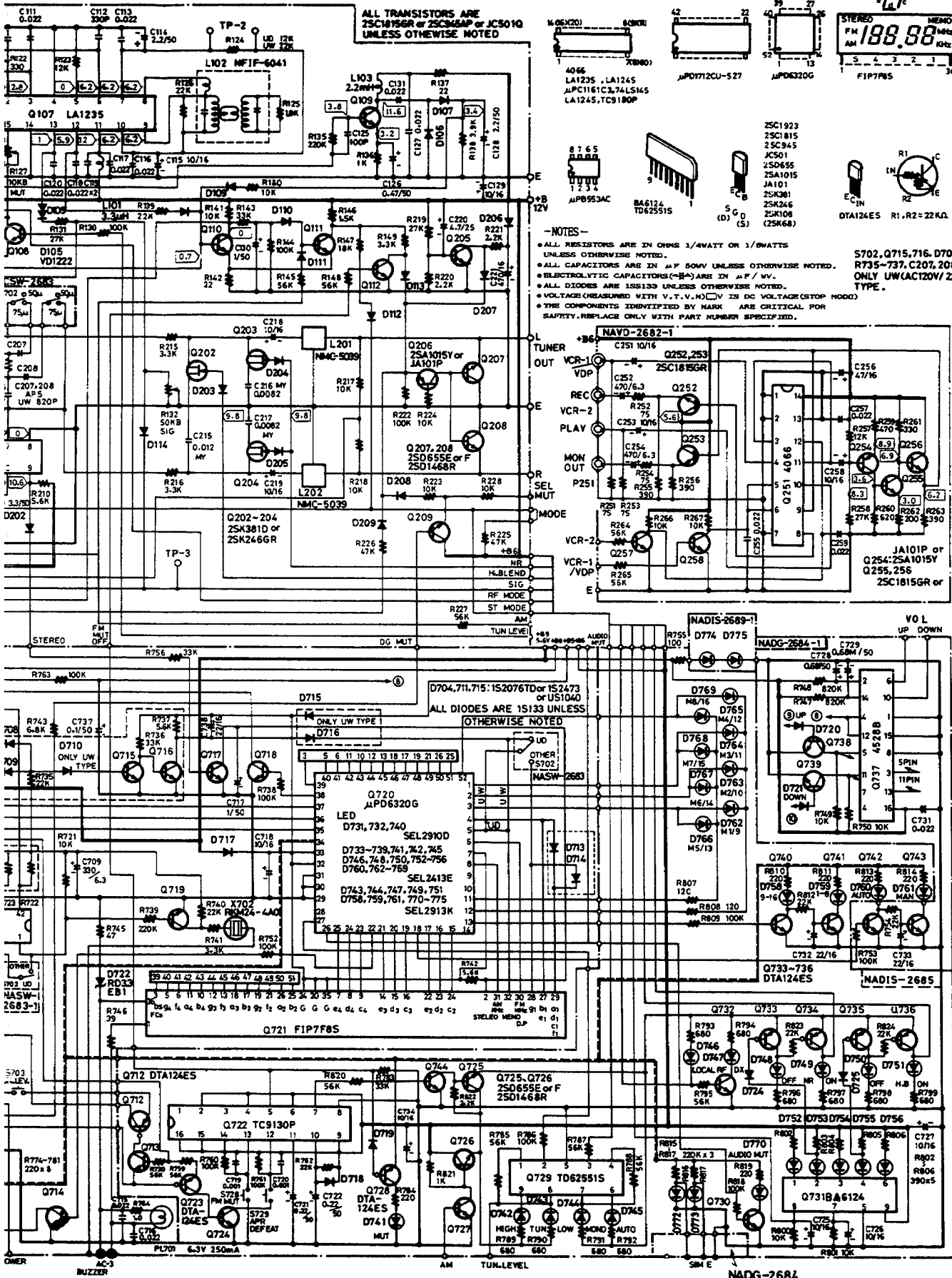

A

B

C

D

# SCHEMATIC DIAGRAM -AMPLIFIER SECTION-

TX-88

1

S901	MAIN POWER	OFF	ON
S902	SYSTEM POWER	OFF	ON
S321	VCR-MODE	ST	MONO
S351	S.S.	OFF	ON
S353	D.B.E.	OFF	ON
S571	MODE	OFF	ON
S572	MUTING	OFF	ON
S581	LOUDNESS	OFF	ON
S502	SPEAKERS	OFF	ON
S904	VOLUME	120V	220V

2

3

4

5

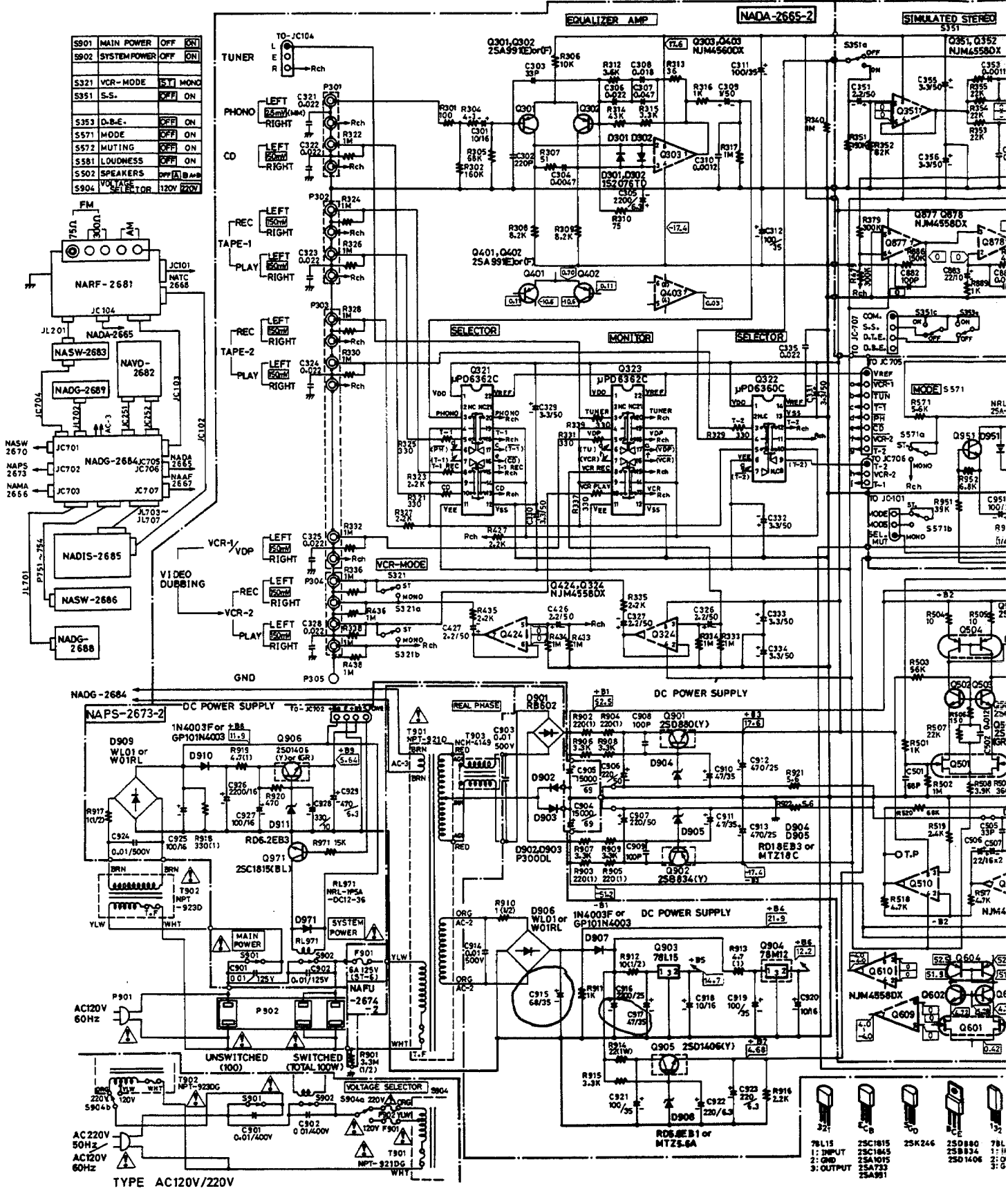

TYPE AC120V/220V

- 78L15
- 250B80
- 250B84
- 250B88
- 250B92
- 250B96
- 250B100
- 250B104
- 250B108
- 250B112
- 250B116
- 250B120
- 250B124
- 250B128
- 250B132
- 250B136
- 250B140
- 250B144
- 250B148
- 250B152
- 250B156
- 250B160
- 250B164
- 250B168
- 250B172
- 250B176
- 250B180
- 250B184
- 250B188
- 250B192
- 250B196
- 250B200



# BLOCK DIAGRAM OF IC

TX-88

## Microcomputer operation

### $\mu$ PD-1712CU-527 (Synthesizer and controller)

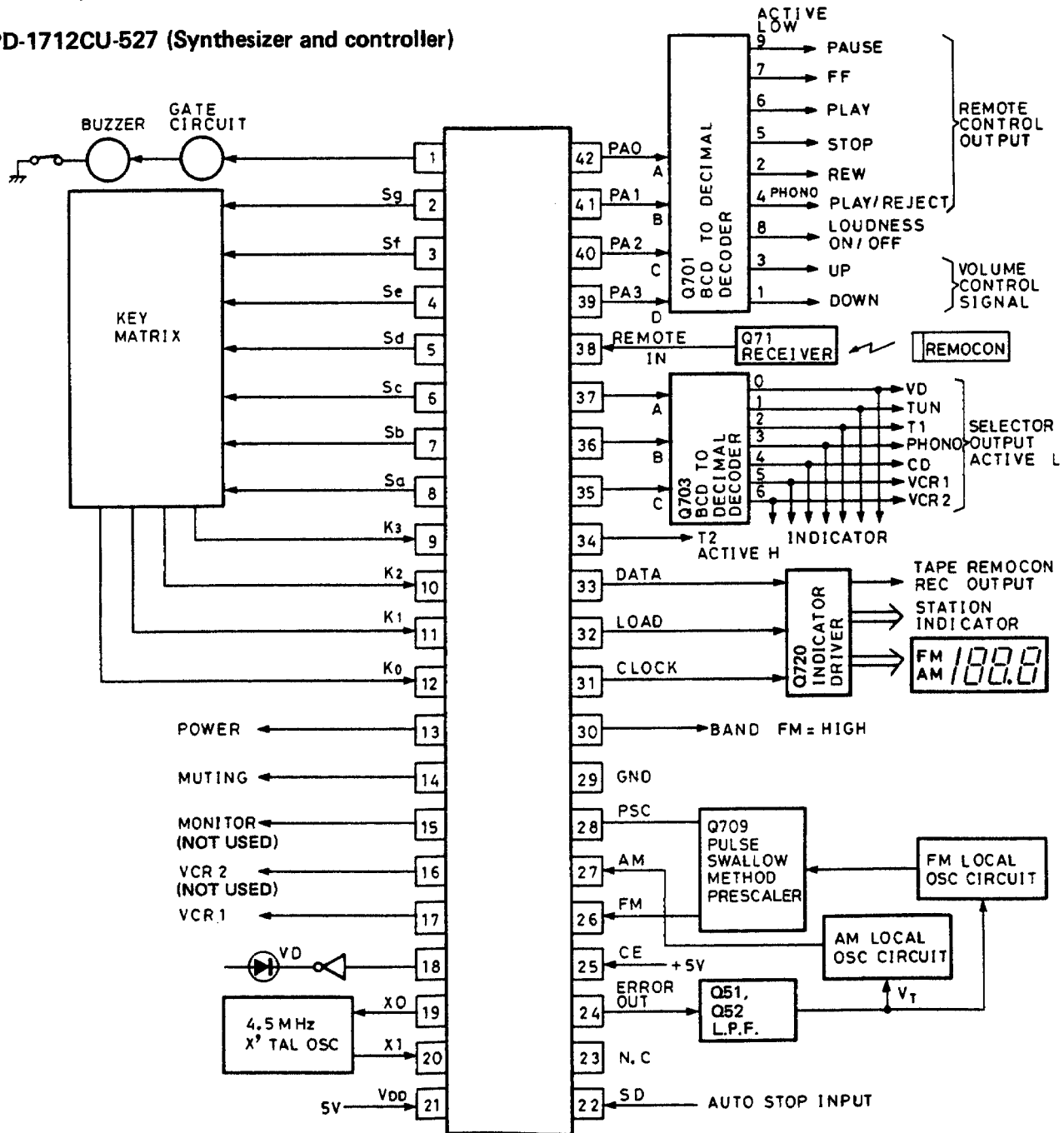

Pin No.	Symbol	Description
1.	CPG	Clock pulse output for buzzer when pressed the operation keies and auto-tuning.
2	Sg	Key return signal source output terminals.
3	Sf	
4	Se	
5	Sd	
6	Sc	
7	Sb	
8	Sa	

Pin No.	Symbol	Description																																																		
9 10 11 12	K3 K2 K1 K0	Key return signal input terminals.																																																		
13	POWER	System power control output. Active high.																																																		
14	MUTE	Goes to the high level during muting control signal output. Active high.																																																		
15	MONITOR	Monitor output terminal for control of video. Active high.																																																		
16	VCR2	VCR2 output terminal for control of video. Active high.																																																		
17	VCR1	VCR1 output terminal for control of video. Active high.																																																		
18	VD	Output terminal for indicator VD. Active high.																																																		
19 20	X0 X1	Connect to the 4.5MHz crystal oscillator.																																																		
21	VDD	Device power terminal; supplies 5V during normal operation and 3V from the super capacitor C710 for memory preservation.																																																		
22	SD	Station detector input terminal. When this terminal goes to the high level, auto search tuning is stopped.																																																		
23 24	E02 E01	Charge pump output of the phase detector which constitutes the PLL. High level is output when the divided local oscillator frequency is high than the reference frequency. In the opposite case, low level is output. Floating occurs when the frequencies matched. The output is applied to the variable capacitor diode in the local oscillator circuit of AM/FM through low pass filter Q151 and Q152. The output from both terminals is the same, but only E01 is used.																																																		
25	CE	Chip enable input. Device selection signal terminal. High level ... Normal operation Low level ... Memory preservation.																																																		
26	FM	Local oscillator frequency input terminal is divided by prescaler Q709.																																																		
27	AM	Local oscillator frequency input terminal.																																																		
28	PSC	Output terminal to control the division ratio of the prescaler Q709.																																																		
29	GND	Ground terminal																																																		
30	FM/AM	FM/AM band selector output. FM at the high level and AM at the low level.																																																		
31	CK	Clock output for indicator driver IC Q718.																																																		
32	LOAD	Load output for indicator driver IC Q718.																																																		
33	DATA	Data output for indicator driver IC Q718.																																																		
34	TAPE 2	TAPE 2 control output terminal. Active high.																																																		
35 36 37	PC2 (C) PC1 (B) PC0 (A)	BCD code output for source selector. <table border="1" data-bbox="711 1549 1334 1701"> <thead> <tr> <th></th> <th>VD</th> <th>TUNER</th> <th>TAPE 1</th> <th>PHONO</th> <th>CD</th> <th>VCR 1</th> <th>VCR 2</th> </tr> </thead> <tbody> <tr> <td>C</td> <td>0</td> <td>0</td> <td>0</td> <td>0</td> <td>1</td> <td>1</td> <td>1</td> </tr> <tr> <td>B</td> <td>0</td> <td>0</td> <td>1</td> <td>1</td> <td>0</td> <td>0</td> <td>1</td> </tr> <tr> <td>A</td> <td>0</td> <td>1</td> <td>0</td> <td>1</td> <td>0</td> <td>1</td> <td>0</td> </tr> </tbody> </table> Active low.		VD	TUNER	TAPE 1	PHONO	CD	VCR 1	VCR 2	C	0	0	0	0	1	1	1	B	0	0	1	1	0	0	1	A	0	1	0	1	0	1	0																		
	VD	TUNER	TAPE 1	PHONO	CD	VCR 1	VCR 2																																													
C	0	0	0	0	1	1	1																																													
B	0	0	1	1	0	0	1																																													
A	0	1	0	1	0	1	0																																													
38	INT	Remote control input.																																																		
39 40 41 42	PA3 (D) PA2 (C) PA1 (B) PA0 (A)	BCD code outputs for the electron volume and remote control signal for tape deck and turntable. <table border="1" data-bbox="721 1789 1393 1986"> <thead> <tr> <th></th> <th>DOWN</th> <th>REW</th> <th>UP</th> <th>PLAY/REJ</th> <th>STOP</th> <th>PLAY</th> <th>FF</th> <th>LOUD</th> <th>PAUSE</th> </tr> </thead> <tbody> <tr> <td>D</td> <td>0</td> <td>0</td> <td>0</td> <td>0</td> <td>0</td> <td>0</td> <td>0</td> <td>1</td> <td>1</td> </tr> <tr> <td>C</td> <td>0</td> <td>0</td> <td>0</td> <td>1</td> <td>1</td> <td>1</td> <td>1</td> <td>0</td> <td>0</td> </tr> <tr> <td>B</td> <td>0</td> <td>1</td> <td>1</td> <td>0</td> <td>0</td> <td>1</td> <td>1</td> <td>0</td> <td>0</td> </tr> <tr> <td>A</td> <td>1</td> <td>0</td> <td>1</td> <td>0</td> <td>1</td> <td>0</td> <td>1</td> <td>0</td> <td>1</td> </tr> </tbody> </table> Active low.		DOWN	REW	UP	PLAY/REJ	STOP	PLAY	FF	LOUD	PAUSE	D	0	0	0	0	0	0	0	1	1	C	0	0	0	1	1	1	1	0	0	B	0	1	1	0	0	1	1	0	0	A	1	0	1	0	1	0	1	0	1
	DOWN	REW	UP	PLAY/REJ	STOP	PLAY	FF	LOUD	PAUSE																																											
D	0	0	0	0	0	0	0	1	1																																											
C	0	0	0	1	1	1	1	0	0																																											
B	0	1	1	0	0	1	1	0	0																																											
A	1	0	1	0	1	0	1	0	1																																											

# BLOCK DIAGRAM

## -TUNER SECTION-

TX-88

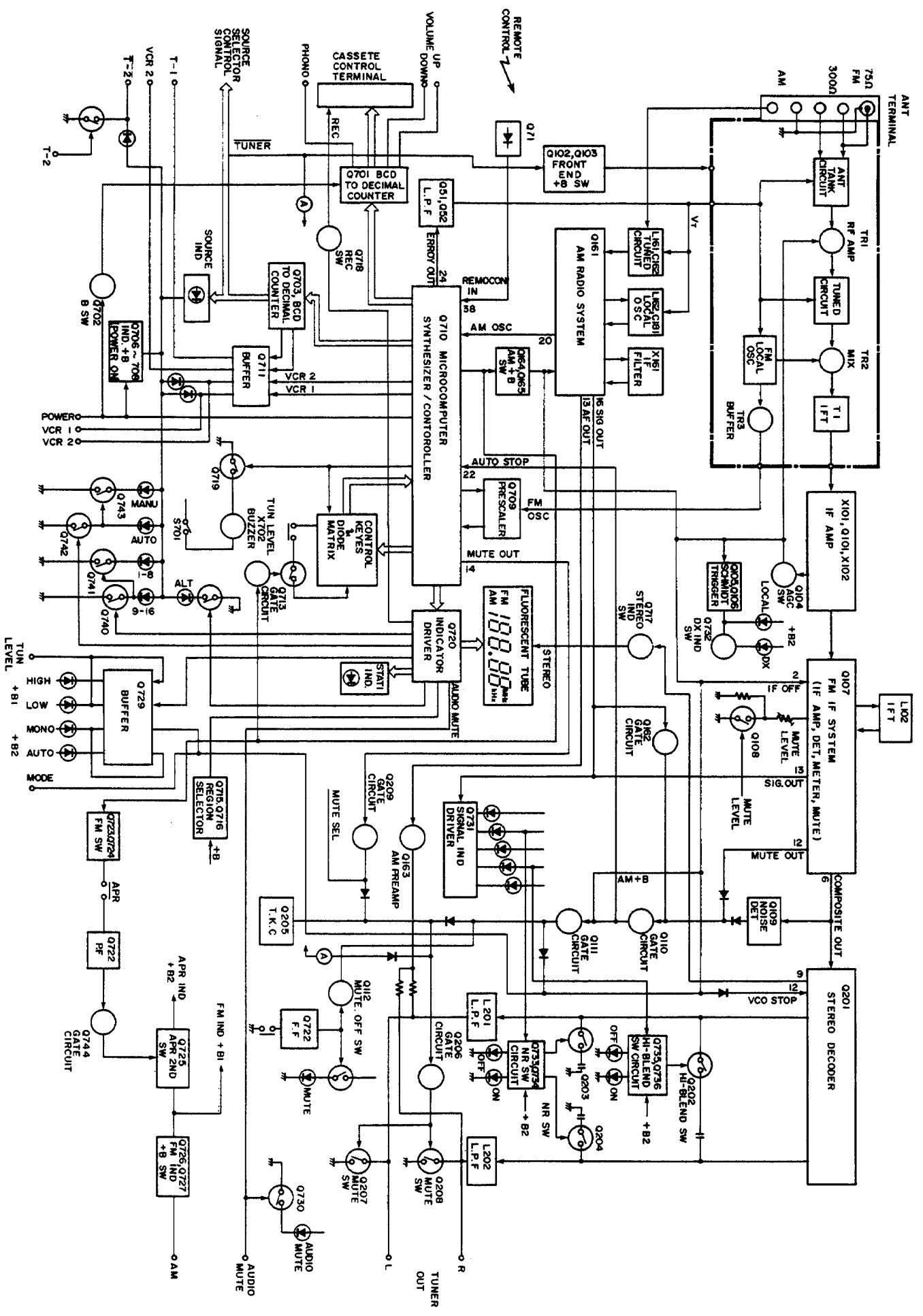

TX-88

Step	AM SG output	Tuned frequency	Output indicator	Adjustment point	Adjust for	Remarks
1		530 kHz (522 kHz)	Digital DC voltmeter	L162	$1.2V \pm 0.5V$	Repeat the steps 1 and 2 until no further adjustment is necessary.
2		1620 kHz (1611 kHz)	Digital DC voltmeter	C181	$9.5V \pm 0.1V$	
3	600 kHz (603 kHz) 400 Hz 30% mod. 60dB/m	600 kHz (603 kHz)	AC voltmeter	L161	Maximum	Repeat the steps 3 and 4 until no further adjustment is necessary.
4	1400kHz(1404kHz) 400 Hz 30% mod. 60dB/m	1400 kHz (1404 kHz)	AC voltmeter	C162	Maximum	
5	1000kHz(999kHz) 400 Hz 30% mod.	1000 kHz (999 kHz)	AC voltmeter	X161	Maximum	Set the output of SG to about 30mV.

( ): 9kHz step model

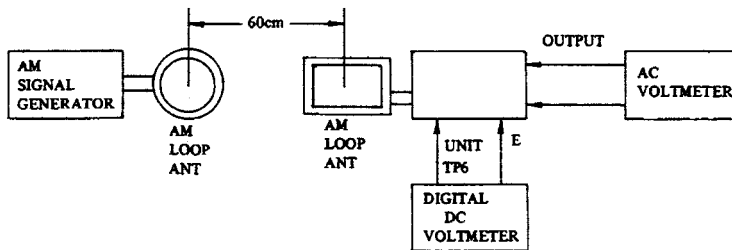



Item	Step	Connection of instrument	FM SG output	Stereo modulator output	Turning dial setting	Output indicator	Adjustment	Adjust for	Remarks
FM IF	1	Fig. 1	99.1 MHz 1 kHz, 75 kHz devi. 65 dBf (60 dB)	—	99.1 MHz	DC voltmeter	L102 Primary coil	0V	Muting switch: off Repeat the steps 1 and 2 until no further adjustment is necessary
	2	Fig. 1	99.1 MHz 1 kHz, 75 kHz devi. 65 dBf (60 dB)	—	99.1 MHz	Distortion analyzer	L102 Secondary coil	Minimum	
VCO		Fig. 2	99.1 MHz 1 kHz, 75 kHz devi. 65 dBf (60 dB)	—	99.1 MHz	Frequency counter	R214	76 kHz ± 10 Hz	Muting switch: on
Stereo Distortion		Fig. 3	99.1 MHz 65 dBf (60 dB) Ext. modulation	L or R ch 1 kHz	99.1 MHz	Distortion analyzer	IF on front end	Minimum	Maximum and same separation
	1	Fig. 3	99.1 MHz 65 dBf (60 dB) Ext. modulation	L ch. 1 kHz	99.1 MHz	R ch. AC voltmeter	R209	Minimum	
Stereo Separation	2	Fig. 3	99.1 MHz 65 dBf (60 dB) Ext. modulation	R ch. 1 kHz	99.1 MHz	L ch. AC voltmeter	R209	Minimum	Maximum and same separation
	1	Fig. 3	99.1 MHz 29.2 dBf (24 dB) 1 kHz, 75 kHz devi.	—	99.1 MHz	Oscilloscope	R127	Signal output	
Muting level	2	Fig. 3	99.1 MHz 28.2 dBf (23 dB) 1 kHz, 75 kHz devi.	—	99.1 MHz	Oscilloscope	R127	No output	Set Tuning level to high Muting switch: on
Signal Indicator level		Fig. 3	99.1 MHz 35.2 dBf (30 dB) 1 kHz, 75 kHz devi.	—	99.1 MHz	4th signal indicator	R132	light on	