

# ONKYO® SERVICE MANUAL

## AUDIO VIDEO CONTROL TUNER AMPLIFIER MODEL TX-DS838



**Black and Golden model**

BUDN	120V AC,60Hz
BUP,GUPT	230V AC,50Hz
BUW,GUW	120V or 220V AC,50/60Hz.

### SAFETY-RELATED COMPONENT WARNING!!

COMPONENTS IDENTIFIED BY MARK  $\triangle$  ON THE SCHEMATIC DIAGRAM AND IN THE PARTS LIST ARE CRITICAL FOR RISK OF FIRE AND ELECTRIC SHOCK. REPLACE THESE COMPONENTS WITH ONKYO PARTS WHOSE PART NUMBERS APPEAR AS SHOWN IN THIS MANUAL.

MAKE LEAKAGE-CURRENT OR RESISTANCE MEASUREMENTS TO DETERMINE THAT EXPOSED PARTS ARE ACCEPTABLY INSULATED FROM THE SUPPLY CIRCUIT BEFORE RETURNING THE APPLIANCE TO THE CUSTOMER.

**ONKYO®**  
**AUDIO COMPONENTS**

# SPECIFICATIONS

## AMPLIFIER SECTION

Power output:	<b>Stereo mode</b> (Surround mode: OFF) L and R FRONT SPEAKERS 100 watts per channel min. RMS. at 8 ohms; both channels driven between 20 Hz and 20,000 Hz with no more than 0.08 % total harmonic distortion. Continuous power 2 x 150 Watt at 6 ohms (DIN) <b>Surround mode</b> L and R FRONT and CENTER SPEAKERS 90 watts per channel min RMS. at 8 ohms three channels driven from 20 Hz to 20,000 Hz, with no more than 0.08% total harmonic distortion. L and R SURROUND SPEAKERS 50 watts per channel min. RMS. at 8 ohms; both channels driven from 20 Hz to 20,000 Hz with no more than 0.08% total harmonic distortion.
IM distortion:	0.08% at rated power (L and R)
Damping factor:	60 at 8 ohms (L and R)
Input sensitivity/impedance:	Phono: 2.5 mV/50 kohms Line (CD, TAPE-1 and - 2, VIDEO-1 ~ 4): 150 mV/50 kohms
Output level/impedance:	OUTPUT (REC) (TAPE-1 and -2): 150 mV/2.2 kohms OUT (VIDEO 1, 2): 150 mV/2.2 kohms PRE OUT (LEFT, RIGHT, LEFT SURROUND, RIGHT SURROUND, SUBWOOFER, CENTER): 1V/470 ohms
Phono overload:	120 mV RMS. at 1,000 Hz, 0.5 % THD.
Frequency response:	20 to 30,000 Hz, +/-0.5 dB
RIAA deviation:	20 to 20,000 Hz, +/-0.8 dB
Tone control:	BASS: +/-10 dB at 50 Hz MIDBASS: +/-10 dB at 300 Hz TREBLE: +/-10 dB at 10,000 Hz
Signal-to-noise ratio:	PHONO: 80 dB (IHF A, 5mV input) (Surround mode: OFF) CD/TAPE: 100 dB (IHF A)
Muting:	-∞dB

## VIDEO SECTION

Television format:	NTSC (U.S. and Canadian models) NTSC/PAL (Other models)
Input sensitivity/impedance	IN (VIDEO-1 ~ 4) VIDEO (Composite): 1 Vp-p/75 ohms IN (VIDEO-1 ~ 4) S-VIDEO (Y signal): 1 Vp-p/75 ohms IN (VIDEO-1 ~ 4) S-VIDEO (C signal): 0.28 Vp-p/75 ohms
Output level/impedance	OUT (VIDEO-1 ~ 2, MONITOR OUT ) VIDEO (Composite): 1 Vp-p/75 ohms OUT (VIDEO-1 ~ 2, MONITOR OUT ) S-VIDEO (Y signal): 1 Vp-p/75 ohms OUT (VIDEO-1 ~ 2, MONITOR OUT ) S-VIDEO (C signal): 0.28 Vp-p/75 ohms

## DIGITAL SECTION

Digital input sampling frequency:	32, 44.1, 48 kHz
Input sensitivity/impedance:	Coaxial: 0.5 Vpp/75 ohms AC-3RF: 0.4 Vpp/75 ohms

## TUNER SECTION

### FM:

Tuning range:	87.50 – 108.00 MHz (50 kHz steps)
Usable sensitivity:	Mono: 11.2 dBf, 1.0 μV (75 ohms) Stereo: 17.2 dBf, 2.0 μV (75 ohms)
50-dB Quieting sensitivity:	Mono: 17.2 dBf, 2.0 μV (75 ohms) Stereo: 37.2 dBf, 20 μV (75 ohms)
Capture ratio:	1.5 dB
Image rejection ratio:	40 dB (U.S. and Canadian models) 85 dB (European models) 85 dB (Worldwide model)
IF rejection ratio:	90 dB
Signal-to-noise ratio:	Mono: 76 dB Stereo: 70 dB
Alternate channel Attenuation:	55 dB
AM suppression ratio:	50 dB
Harmonic distortion:	Mono: 0.1% Stereo: 0.2%
Frequency response:	30 – 15,000 Hz ± 1.0 dB
Stereo separation:	45 dB at 1kHz 30 dB between 100 and 10,000 Hz
Muting level:	17.2 dBf

### AM:

Tuning:	U.S. and Canadian models 530 to 1710 kHz (10 kHz steps) European models 522 to 1611 kHz (9 kHz steps) Worldwide models 530 to 1710 kHz (10 kHz steps) or 531 to 1602 kHz (9 kHz steps)
Usable sensitivity:	30 μV
Image rejection ratio:	40 dB
IF rejection ratio:	40 dB
Signal-to-noise ratio:	40 dB
Harmonic distortion:	0.7%

## GENERAL

Power supply: U.S. and Canadian models	AC120V, 60 Hz
European models	AC 230V, 50 Hz
Worldwide model	120/220 – 230 V switchable, 50/60 Hz
Dimensions (W x H x D):	435 x 175 x 428 mm (17-1/8" x 6-7/8" x 16-7/8")
Weight:	16.5 kg (36.4 lbs.)

## REMOTE CONTROL RC-P101S, RC-P201S

Transmitter:	Infrared
Signal range:	Approx. 5 meters (16 ft.)
Power supply:	Two AA batteries (1.5 V x 2)

Specifications and features are subject to change without notice.

## SERVICE GUIDE

### 1. Replacing the fuses

 This symbol located near the fuse indicates that the fuse used is fast operating type. For continued protection against fire hazard, replace with same type fuse. For fuse rating refer to the marking adjacent to the symbol.

 Ce symbole indique que le fusible utilise est a rapide. Pour une protection permanente, n'utiliser que des fusibles de meme type. Ce dernier est indique la qu le present symbol est appose.

CIRCUIT NO.	PART NO.	DESCRIPTION
F901	252155	△ 10A-TSC, Fuse <D/W>
F902	252078	△ 5A-SE-EAK, Fuse <P/W/K>
F903	252075	△ 2.5A-SE-EAK, Fuse <P>
F915, F916	252153	△ 6.3A-TSC, Fuse <D>
	252079	△ 6.3A-SE-EAK, Fuse <P/W/K>
NOTE: <D>: 120V model only      <P>: 230V model only		
<W>: Worldwide model only <K>: Korean model only		

### 2. To Initialize the unit

This device employs a microprocessor to perform various functions and operations. If interference generated by an external power supply, radio wave, or other electrical source results in accident which causes the specified operations and functions to operate abnormally.

To perform a result, please follow the procedure below.

1. Turn POWER button on.
2. Press and hold down the VIDEO-1 button, then press SPEAKER button.
3. After "clear" is displayed, the preset memory and each mode stored in the memory, such as surround, are initialized and will return to the factory settings.

### 3. Safety-check out

(Only U.S.A. model)

After correcting the original service problem, perform the following safety check before releasing the set to the customer. Connect the insulating-resistance tester between the plug of power supply cord and the screw on the back panel.

Specifications: 3.3 Mohm±10% at 500V.

### 4. Change of voltage

Worldwide models are equipment with a voltage selector to conform with local power supplies. This switch is located on the back panel.

Be sure to set this switch to match the voltage of the power supply in your area before turning the power switch on.

This switch is set to 220V at the factory. Voltage is changed by

sliding the groove in the switch with the screwdriver to the right or left. Confirm that the switch has been moved all the way to the right or left before turning the power switch on.

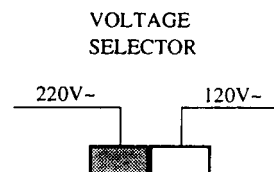

### 5. Memory preservation

This unit does not require memory preservation batteries.

A built-in memory power back-up system preserves contents of the memory during power failures and even when the unit is unplugged.

The unit must be plugged in and the power switch turned on and off once in order to charge the back-up system. Note that since this is not a permanent memory, the power switch must be turned on and off a few times each month the keep the back-up system operative.

The period of the time during which memory contents are preserved after power has last been turned off varies depending on climate and placement of the unit. On the average, memory contents are protected over a period of 3 to 4 weeks (a minimum of 2 weeks) after the last time power has been turned off. This period is shorted when the unit is exposed to very high humidity or used in an area with an extremely humid climate.

### 6. Setting the tuning step frequency

Worldwide models are equipped with a step band selector switch. This switch is located on the back panel. This switch is set to 9 kHz at the factory, but may have to be reset to 10 kHz depending on the area where the unit is used.

AM band step  
 Europe: 9 kHz  
 U.S.A.: 10 kHz

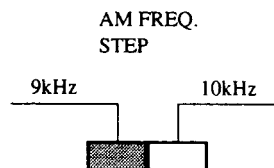

### 7. Changing the band step

With the exception of the worldwide models, a tuning step selector switch is not provided. When you change the band step, change the parts as shown below.

	To 10kHz	To 9kHz
R1750,R1751	Remove	10kohm
R1747,R1748	10kohm	Remove

# BLOCK DIAGRAM TUNED SECTION

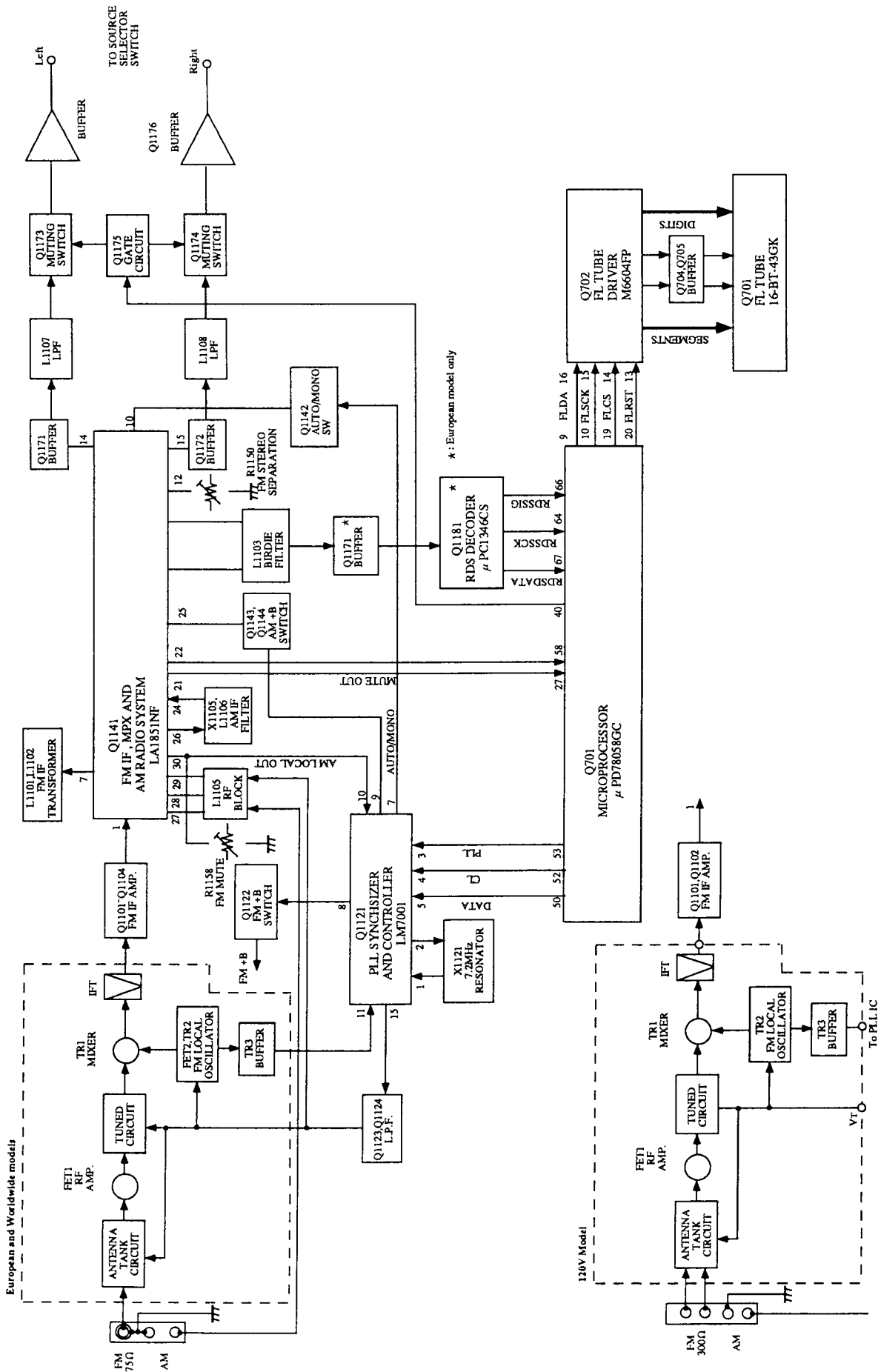

VIDEO SECTION

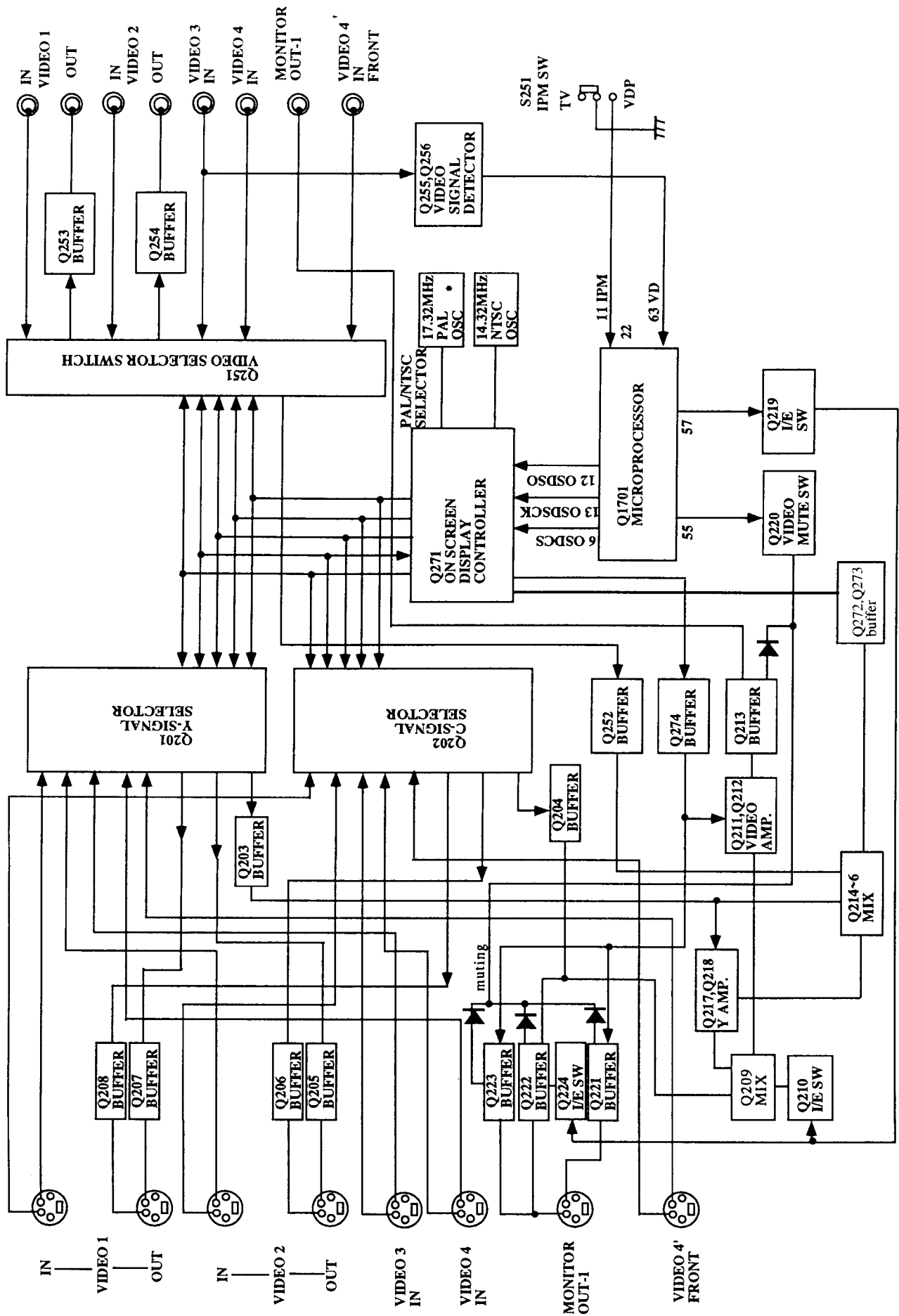

POWER SUPPLY SECTION

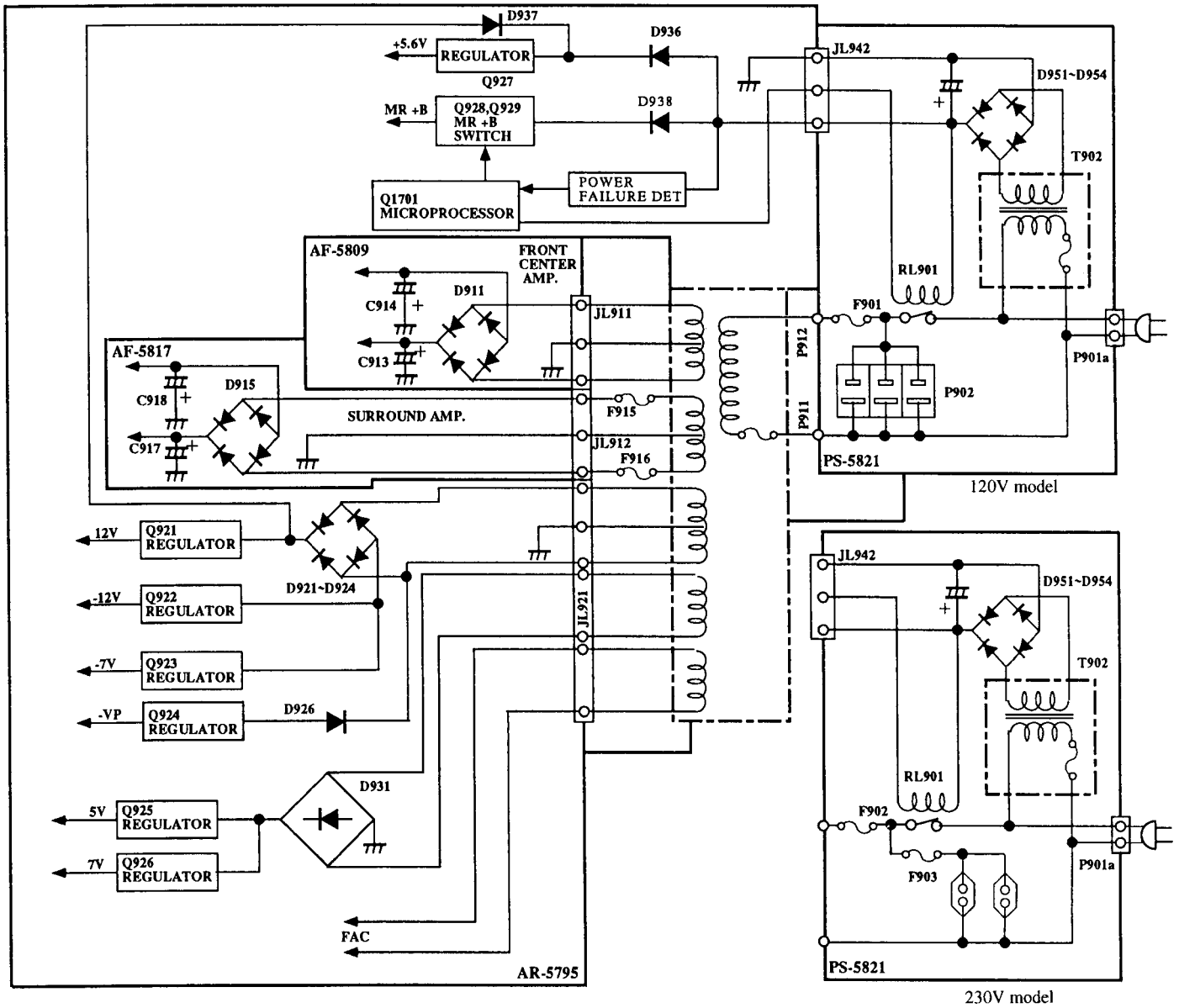

# MICROPROCESSOR-CONNECTION DIAGRAM MAIN MICROPROCESSOR

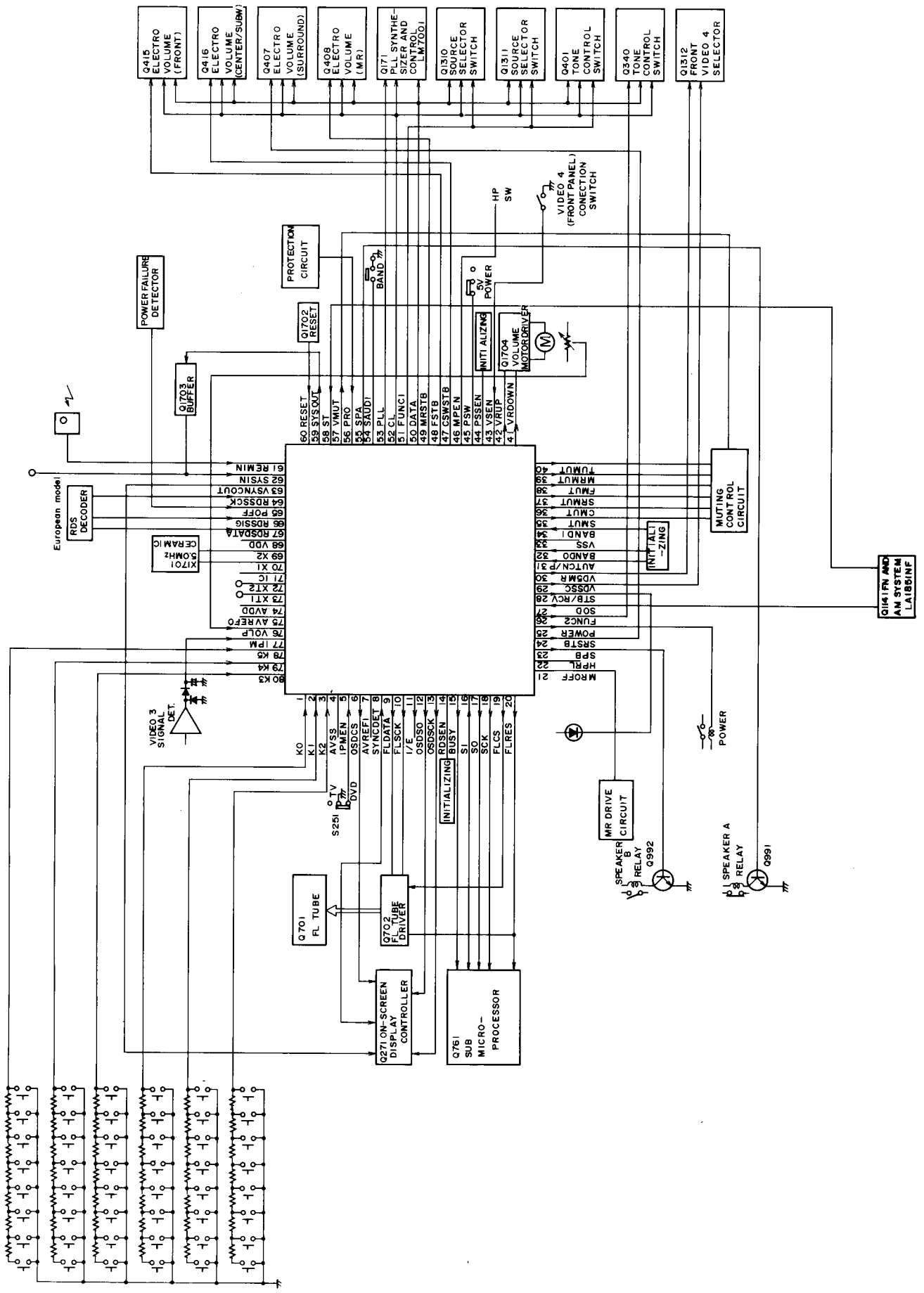

## MICROPROCESSOR-TERMINAL DESCRIPTIONS

No.	Mark	Symbol	Description
1	P15/ANI5	K3	Operation key connection pin
2	P16/ANI6	K4	Operation key connection pin
3	P17/ANI7	K5	Operation key connection pin
4	AV <sub>ss</sub>	AVSS	Ground voltage pin for A/D converter
5	P130/ANO0	IPMEN	IPM operation selector pin.
6	P131/ANO1	OSDCS	Output pin to connect to the terminal CS for OSD controller LC74761
7	AVREF	AVREF1	Reference voltage pin for D/A converter
8	P70/S12/RxD	SYNCDT	Judge input pin for external synchronizing of OSD IC
8			External synchronizing when high level
9	P71/SO2/TxD	FLSDATA	Data output pin to connect to pin SDTAT of FL tube driver IC
10	P72/SCK2/ASCK	FLSCK	Clock output pin to connect to pin SCK of FL tube driver IC
11	P20/S11	EXT/INT	Output pin to show the status of synchronizing for OSD IC. High level when external synchronizing
12	P21/S01	OSDSO	Output pin to connect to the pin SIN of OSD controller
13	P22/SCK1	OSDSCK	Output pin to connect to the pin SCLK of OSD controller
14	P23/STB	RDSEN	Initializing input for RDS
15	P24/BUSY	BUSY	Busy pin for transfer to the sub microprocessor
16	P25/S10/SB0	SI	Data input pin for transfer to the sub microprocessor
17	P26/SO0/SB1	SO	Data output pin for transfer to the sub microprocessor
18	P27/SCK0	SCK	Clock output pin for transfer to the sub microprocessor
19	P40/AD0	FLCS	Output pin to connect to pin CS of FL tube driver
20	P41/AD1	FLRES	Output pin to connect to pin RES of FL tube driver Use the reset signal of sub microprocessor when power on
21	P42/AD2	MROFF	Multi room indicator and control output pin
22	P43/AD3	HPRL	Headphone relay control output pin
23	P44/AD4	SPBRL	Speaker B relay control output pin
24	P45/AD5	SRSTB	Strobe output pin to connect to the pin STB of electro. volume
25	P46/AD6	POWER	Power source control pin
26	P47/AD7	FUNC2	Strobe output pin to connect to the pin ST of function switch
27	P50/A8	SD	Station detection pin
28	P51/A9	STBY/RCV	RECEIVED or STANDBY indicator control output pin
29	P52/A10	V-4F	Control output pin for VIDEO-4 on the front panel. On when high level.
30	P53/A11	V-4F'	Control output pin for multi-source and recording of VIDEO-4 on the front panel. On when high level.
31	P54/A12	AUTONP	Initializing pin to select NTSC or PAL.
32	P55/A13	BAND0	Initializing pin for band range of FM/AM
33	V <sub>ss</sub>	VSS	Ground pin
34	P56/A14	BAND1	Initializing pin for band range of FM/AM
35	P57/A15	WMUT	Muting control output pin for sub-woofer. On when high level
36	P60	CMUT	Muting control output pin for center amplifier On when high level
37	P61	SRMUT4	Muting control output pin for surround amplifier On when high level
38	P62	FMUT	Muting control output pin for front amplifier On when high level
39	P63	MRMUT	Muting control output pin for multi-amplifier On when high level
40	P64/RD	TUMUT	Muting control output pin for tuner section. On when high level

BAND1	BAND0	SAUDI	Region	Band	Frequency Range	Channel Space
0	0		U.S.A	FM	87.50~108.00MHz	50kHz
				AM	530~1710kHz	10kHz
0	1		Japan	FM	76.0~90.0MHz	100kHz
				AM	522~1629kHz	9kHz
1	0	1*	Worldwide	FM	87.50~108.00MHz	50kHz
				AM	531~1602kHz	9kHz
1	1		Europe	FM	87.50~108.00MHz	50kHz
				AM	522~1611kHz	9kHz

The region becomes U.S.A band when this terminal is low.



No.	Mark	Symbol	Description															
41	P65/WR	VOLDOWN	Volume control output pin															
42	P66/WAIT	VOLUP	These pins change as the below table by the signal from remote control transmitter. <table border="1" style="margin-left: 20px;"> <thead> <tr> <th>Operation</th> <th>VOLUP</th> <th>VOLDOWN</th> </tr> </thead> <tbody> <tr> <td>STOP</td> <td>H</td> <td>H</td> </tr> <tr> <td>When UP</td> <td>H</td> <td>L</td> </tr> <tr> <td>When DOWN</td> <td>L</td> <td>H</td> </tr> <tr> <td>Power OFF</td> <td>L</td> <td>L</td> </tr> </tbody> </table>	Operation	VOLUP	VOLDOWN	STOP	H	H	When UP	H	L	When DOWN	L	H	Power OFF	L	L
Operation	VOLUP	VOLDOWN																
STOP	H	H																
When UP	H	L																
When DOWN	L	H																
Power OFF	L	L																
43	P67/ASTB	V-4FEN	Detector input pin for VIDEO-4 on the front panel This pin becomes the high level when the video cassette deck is connected to VIDEO-4 on the front panel. When this pin is high, the selector switch is changed the VIDEO-4 on the front panel. When this pin is low, the selector switch is changed the VIDEO-4 on the rear panel.															
44	P30/TO0	PSWEN	Initializing input to use the mechanical power switch.															
45	P31/TO1	PSW	Input pin for mechanical power switch.															
46	P32/TO2	HPIN	Detection input pin for insertion of headphone When the headphone is used, the surround mode turns off.															
47	P33/TI1	CWSTB	Strobe output pin to connect to the terminal STB of electro volume.															
48	P34/TI2	FSTB	Strobe output pin to connect to the terminal STB of electro volume.															
49	P35/PCL	MRSTB	Strobe output pin to connect to the terminal STB of electro volume.															
50	P36/BUZ	DATA	Data output pin to the function switch, PLL, and electro volume ICs.															
51	P37	FUNC1	Strobe output pin to the function switch ICs.															
52	P120/RTP0	CL	Strobe output pin to the function switch, PLL and electro volume ICs.															
53	P121/RTP1	PLL	Chip enable output pin to PLL IC.															
54	P122/RTP2	SAUDI	Initializing pin for band range of FM/AM															
55	P123/RTP3	SPARL	Control output pin for speaker relay A. On when high level.															
56	P124/RTP4	PROTECT	Input pin to operate the protection circuit. When this pin becomes the low level more than 20 $\mu$ sec, a protection circuit operates.															
57	P125/RTP5	VMUT	Muting control output for video signal															
58	P126/RTP6	STEREO	Input pin to detect the stereo broadcast. Low level when stereo broadcast.															
59	P127/RTP7	SYSOUT	System code output pin															
60	RESET	RESET	System reset input pin.															
61	P00/INTP0/TI00	REMIN	Remote control signal input pin															
62	P01/INTP1	SYSIN	System code input pin															
63	P02/INTP2	VSYNC	Vertical synchronizing signal input pin															
64	P03/INTP3	RDSSCK	Clock input pin from RDS decoder.															
65	P04/INTP4	POFF	Detection input pin for power failure.															
66	P05/INTP5	RDSSIG	Detection input pin for RDS broadcast.															
67	P06/INTP6	RDSDATA	Data input pin from RDS decoder.															
68	VD D	VDD	Power supply pin															
69	X2	X2	Crystal connection pins for main system clock															
70	X1	X1	These pins is connected to the 5MHz resonator.															
71	IC	IC	Internal connection pin.															
72	XT2	XT2	Crystal connection pins for sub system clock															
73	XT1/P07	XT1	Not used.															
74	AVDD	AVDD	Analog power supply pin for A/D converter.															
75	AVREF0	AVREF	Reference voltage input pin for A/D converter.															
76	P10/ANI0	VOLP	Input pin to detect the position of master volume.															
77	P11/ANI1	IPM	Input pin to detect the operation of Intelligent Power Management															
78	P12/ANI2	K0	Operation key connection pin															
79	P13/ANI3	K1	Operation key connection pin															
80	P14/ANI4	K2	Operation key connection pin															

**MICROPROCESSOR-CONNECTION DIAGRAM  
SUB MICROPROCESSOR**

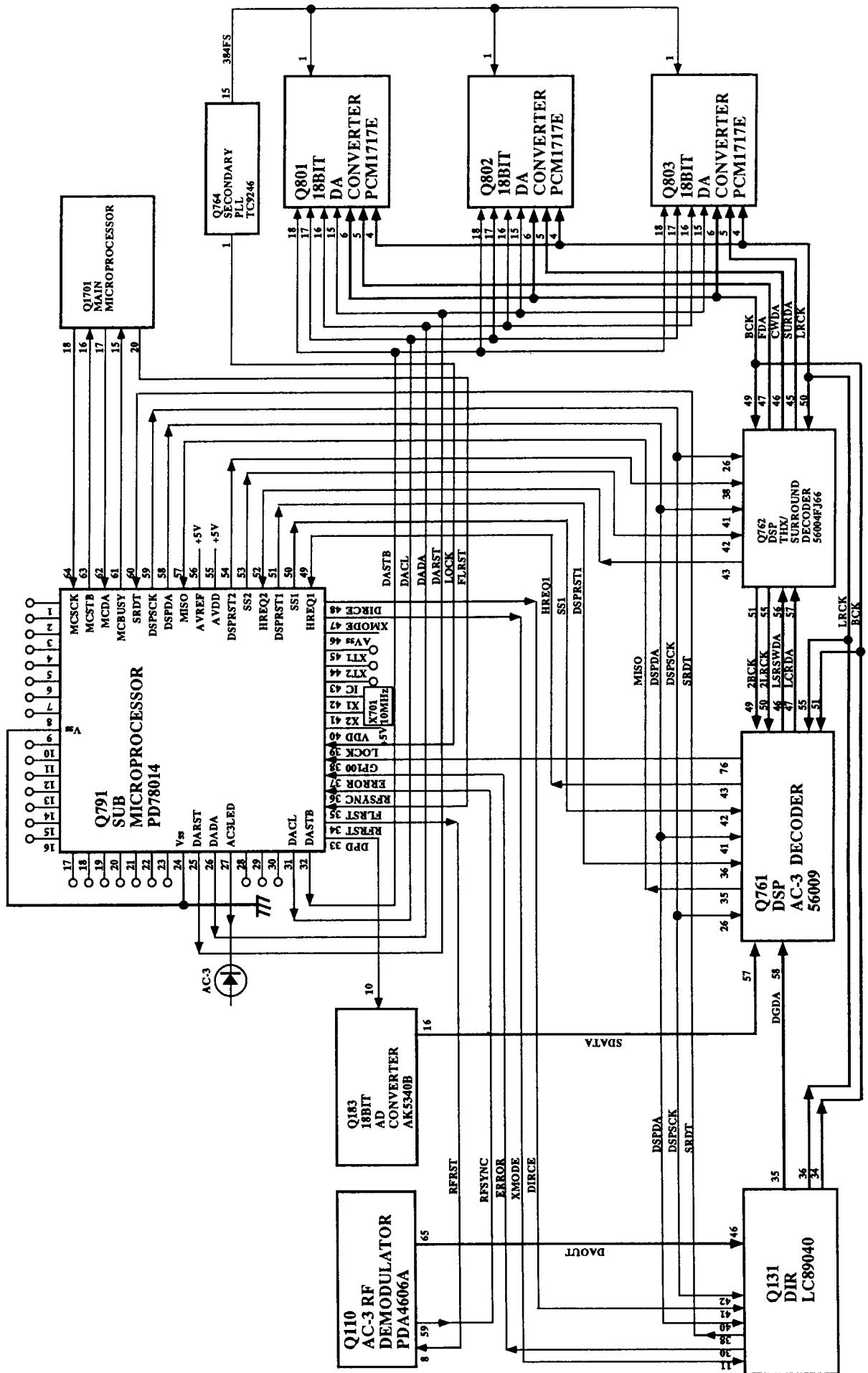

## MICROPROCESSOR-TERMINAL DESCRIPTIONS

Pin No.	Terminal	Description
1-8	NC	
9	VSS	Ground terminal
10-23	NC	
24	VSS	Ground terminal
25	DARSTB	Output terminal to connect to the terminal RSTB of D/A converter PCM1717E.
26	DAMD	Data output terminal to connect to the terminal MD of D/A converter.
27	AC-3LED	"AC-3" indicator control output terminal
28-30	NC	
31	DAMC	Clock output terminal to connect to the terminal MC of D/A converter.
32	DAML	Load output terminal to connect to the terminal ML of D/A converter.
33	DPD	Digital power down control output terminal
34	RFRST	Reset output terminal for AC-3 RF demodulator.
35	RESRT	System reset input terminal
36	RFSYNC	Synchronizing detection input pin for AC-3 RF demodulator
37	ERROR	Input terminal to connect to terminal ERROR of DIR IC LC8904Q.
38	GPI00	Input terminal to connect to terminal GPI00 of DST IC.
39	LOCK	Input terminal to connect to the terminal LOCK of clock generation IC TC9246F.
40	VDD	Power supply (5V)
41	X2	Crystal resonator connection terminals for main system.
42	X1	Connect the ceramic resonator 10MHz.
43	IC	Internal connection terminal
44	XT2	Sub system clock connection terminals.
45	XT1	Not used.
46	AVSS	Ground terminal for A/D converter
47	XMODE	Output terminal to connect to the terminal XMODE of DIR IC LC8904Q.
48	DIRCE	Chip enable output terminal to connect to the terminal CE of DIR IC LC8904Q.
49	HREQ1	Input terminal to connect to the terminal HREQ of DSP IC DSP56009.
50	SS1	Input terminal to connect to the terminal SS of DSP IC DSP56009.
51	DSPRST1	Input terminal to connect to the terminal RESET of DSP IC DSP56009.
52	HREQ2	Input terminal to connect to the terminal HREQ of DSP IC DSP56004.
53	SS2	Input terminal to connect to the terminal SS of DSP IC DSP56004.
54	DSPRST2	Input terminal to connect to the terminal RESET of DSP IC DSP56004.
55	AVDD	Power supply circuit for analog section
56	AVREF	Reference voltage input terminal for A/D converter
57	DSPSI	Input terminal to connect to the terminal MOSI of DSP IC DSP56009.
58	DSPSO	Data output terminal. Connect to the terminal MOSI of DSP ICs and the terminal DI OF DIR IC.
59	DSPSCK	Clock output terminal. Connect to the terminal SCK of DSP ICs and the terminal CL OF DIR IC.
60	SRDT	Input terminal to connect to the terminal SRDT of DIR IC.
61	BUSY	Busy signal output terminal to main microprocessor.
62	SI	Data input terminal from main microprocessor.
63	SO	Data output terminal to main microprocessor.
64	SCK	Clock input terminal for main microprocessor

## ADJUSTMENT PROCEDURES

### Preparation

#### 1. Input

FM mono: 1kHz, 75kHz devi., 60dB/ $\mu$  V

FM stereo: 1kHz, L+R 67.5kHz devi., 60dB/ $\mu$  V

Pilot signal 19kHz 7.5kHz devi.

AM: 400Hz, 30% mod.

#### 2. Outputs

Connect the non-inductive type resistor of 8 ohms to the all speaker terminals unless otherwise noted.

### Idling Current Adjustment

Connect the DC voltmeter to the terminals P507, P508, and P509 ( IB and +B ) on the main amplifier circuit pc board. Turn POWER on. Adjust the trim resistors R522, R622, and R1522 so that the indicator of voltmeter becomes  $4 \pm 0.5\text{mV}$ .

Check the voltage of these terminals about 5 minutes after adjustment.

When the voltage is less than 4.0mV, adjust trim resistors so that the indicator of voltmeter becomes  $5 \pm 1.0\text{mV}$ .

When the voltage is 4.0mV to 8mV, you are not necessary to adjust.

When the voltage is more than 8.0mV, adjust trim resistors so that the indicator of voltmeter becomes  $7 \pm 1.0\text{mV}$ .

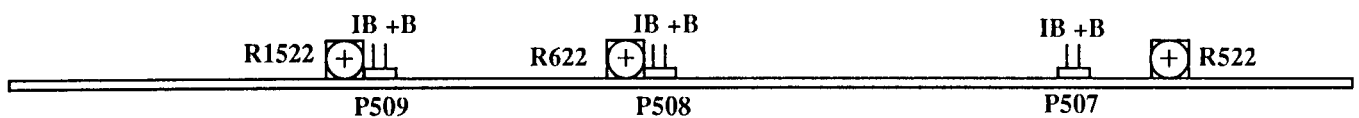

NAAF-5809

# ADJUSTMENT PROCEDURES

## 1. FM ADJUSTMENT

Item	Step	Connection of instrument	FM SG output	Stereo modulator output	Tuning frequency	Output indicator	Adjustment point	Adjust for	Remarks
FM IF/RF	1	Fig.1	99.0MHz, 1kHz 75kHz devi. 65dBf(60dBu)	—	99.00MHz	DC voltmeter	L1101	0 ± 20mV	FM MUTE/MODE switch: ON/AUTO Repeat the steps 1 and 3 until no further adjustment is necessary.
	AC voltmeter					IFT on the front end	Maximum		
	Distortion analyzer					L1102	Minimum		
Stereo Distortion		Fig.2	99.0MHz Ext. mod. 65dBf(60dB)	Channel L or R 1kHz	99.00MHz	Distortion analyzer	IFT on the front end	Minimum	Don't turn more than ±180°
Stereo Separation	1	Fig.2	99.0MHz Ext. mod. 65dBf(60dB)	Channel L 1kHz	99.00MHz	Channel R AC voltmeter	R1150	Minimum	Maximum and same separation
	2			Channel R 1kHz		Channel L AC voltmeter		Minimum	
Muting Level		Fig.2	99.0MHz 1kHz 22.5kHz devi. 19.2dBf(14dB)	—	99.00MHz	Oscilloscope	R1158	Signal output	
RDS		Fig.3	99.10MHz Ext. mod. 60dB	RDS data or 57kHz 3% devi.	99.00MHz	Oscilloscope	R1191	Maximum	European model only

## 2. AM ADJUSTMENT

### 120V model

Step	AM SG output	Tuning Frequency	Output Indicator	Adjustment point	Adjust for
1		530kHz	Digital DC voltmeter	OSC coil on RF block L1105	1.4 ± 0.2V
2	600kHz 400Hz 30% mod. 60dB/m	600kHz	AC voltmeter	RF coil on RF block L1105	Maximum
3	990kHz 400Hz 30% mod. 60dB/m	990kHz	AC voltmeter	L1106	Maximum

### Reference Specification

FM tuned voltage: 87.50MHz ~ 108.00MHz  
 More than 1.0V ~ Less than 9.0V  
 AM tuned voltage: 530kHz ~ 1710kHz  
 1.3 ± 0.2 ~ Less than 9.0V

### 230V and Worldwide models

Step	AM SG output	Tuning Frequency	Output Indicator	Adjustment point	Adjust for
1		522kHz or 531kHz	Digital DC voltmeter	OSC coil on RF block L1105	1.3 ± 0.2V
2	603kHz 400Hz 30% mod. 60dB/m	603kHz	AC voltmeter	RF coil on RF block L1105	Maximum
3	999kHz 400Hz 30% mod. 60dB/m	999kHz	AC voltmeter	L1106	Maximum

### Reference Specification

FM tuned voltage: 87.50MHz ~ 108.00MHz  
 More than 1.0V ~ Less than 9.0V  
 AM tuned voltage: 522kHz ~ 1611kHz  
 1.3 ± 0.2 ~ Less than 9.0V (230V model)  
 AM tuned voltage: 531kHz ~ 1602kHz  
 1.3 ± 0.2 ~ Less than 9.0V (Worldwide model)

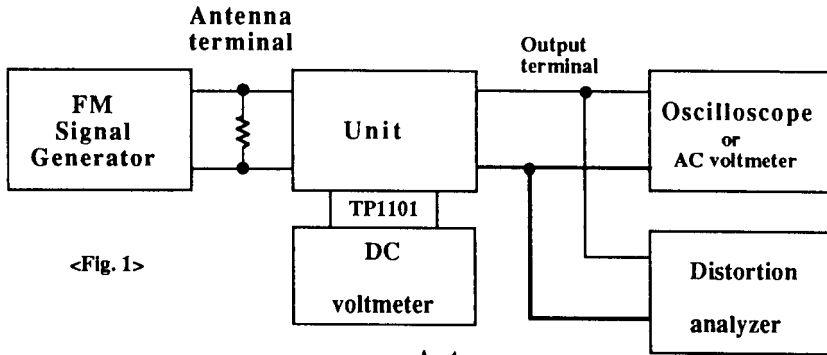

<Fig. 1>

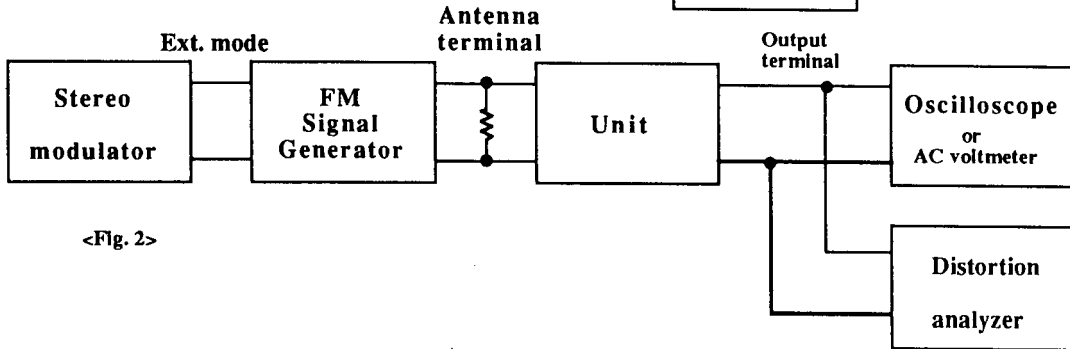

<Fig. 2>

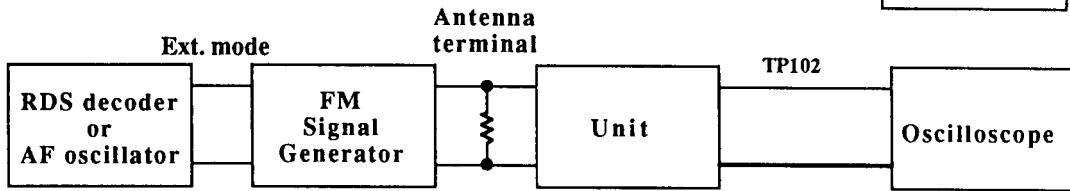

<Fig. 3>

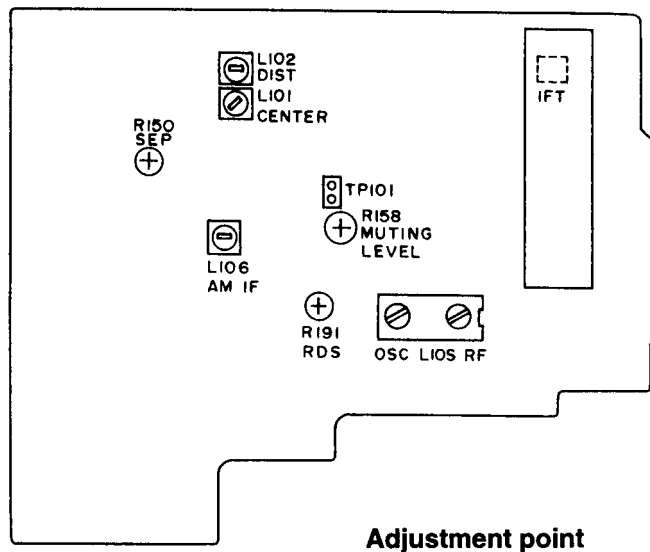
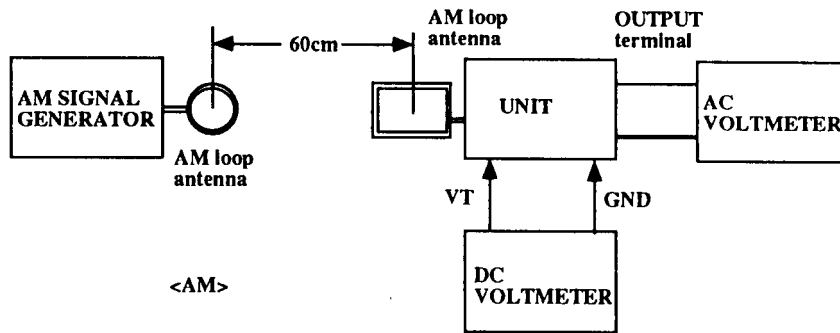

# SCHEMATIC DIAGRAM

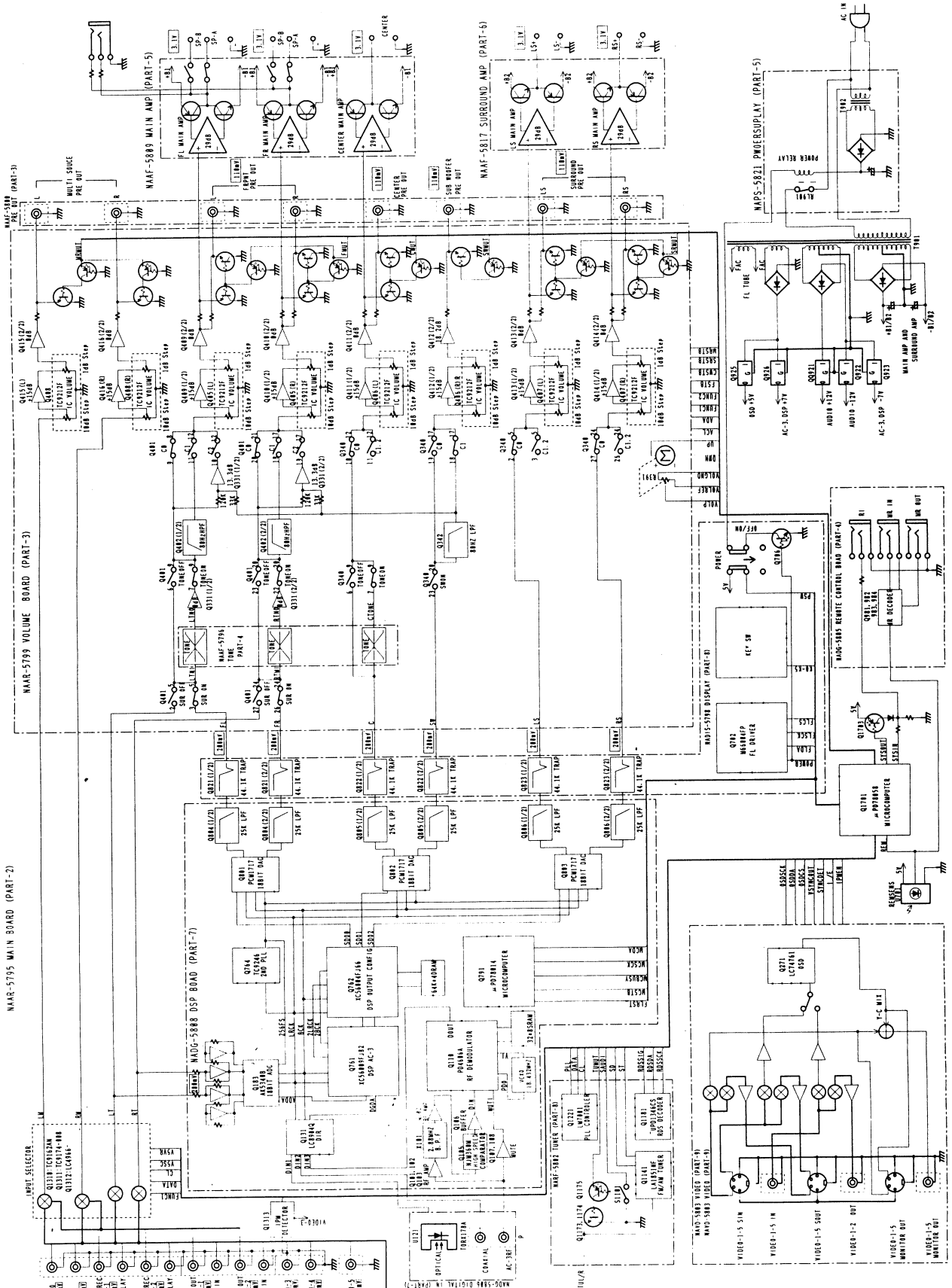

MAAF-5889 MAIN BOARD (PART-2)

MAAF-5799 VOLUME BOARD (PART-3)

MAAF-5817 SURROUND AMP (PART-5)

MAAF-5889 MAIN AMP (PART-5)

MAFS-5821 POWER DISPLAY (PART-5)

MAAF-5799 VOLUME BOARD (PART-3)

MAAF-5817 SURROUND AMP (PART-5)

MAAF-5889 MAIN BOARD (PART-2)

A

B

C

D

E

F

G







**DSP CIRCUIT PC BOARD (NADG-5808-1)**

CIRCUIT NO.	PART NO.	DESCRIPTION
<b>ICs</b>		
Q102	22240976R1	MC14577A
Q105	22240977R2	NJM360M
Q106	222740045R1TO	TC74HCU04AF
Q107,Q109	22240581R1	NJM4565M
Q110	22240973R3	PD4606A
Q111,Q112	22240985R3 or 22241036R9	TC55257CFL-85 or MSM5256CFP-70
Q131	22240915R3	LC8904Q
Q181,Q182	22240581R1	NJM4565M
Q183	22241013R2	AK5340B
Q761	22240972R3	DSP56009FJ80
Q762	22240940R3	XC56004FJ66
Q763	22240720 or 22240867	LH2464-10 or LC32464P-80
Q764	22240928R2	TC9246F
Q791	22241033R3	MPD78P014FGC
Q801~Q803	22241035R2	PCM1717E
Q804~Q806	22240581R1	NJM4565M
Q891	222780053JRC	NJM78L05A
Q892	222780055JRC	NJM78M05FA
Q893	222790053JRC	NJM79L05A
<b>Transistors</b>		
Q101,Q103	2213143R2	2SC2712-O
Q104	2214373R2	2SA1162-O
Q108	2214373R2	2SA1162-O
<b>Diodes</b>		
D101	223236R2	KV1851-TL
D151	223234R2	1SS352
<b>Coils</b>		
L101	233493K680	NCH-1487-680K
L102~L105	231237K470R2	NCH-1479
L131	231237K470R2	NCH-1479
L161,L162	231237K470R2	NCH-1479
L752	230921R2	BLM-21B222ST
L753,L754	231237K470R2	NCH-1479
L761,L762	231237M022R2	NCH-1471-022M
L763	231237K470R2	NCH-1479
L764	231237M022R2	NCH-1471-022M
L801,L802	231237K470R2	NCH-1479
<b>Ceramic filter</b>		
X101	3010263	SBP-4930
<b>Resonators</b>		
X102,X131	3010266	XTL-18.432M, Crystal
X103	3010267	XTL-46.08M, Crystal
X791	3010273R2	CSTCS10.0MT, Ceramic
<b>Capacitors</b>		
C107,C116	356744709R2	CEWX16V, 47M, C-Elect.
C108,C123	356724709R2	CEWX6.3V, 47M, C-Elect.
C124,C130	356724709R2	CEWX6.3V, 47M, C-Elect.
C133,C139	356724709R2	CEWX6.3V, 47M, C-Elect.
C149	356741009R2	CEWX16V, 10M, C-Elect.
C151,C152	356741009R2	CEWX16V, 10M, C-Elect.
C161,C162	356724709R2	CEWX6.3V, 47M, C-Elect.
C166,C766	356724709R2	CEWX6.3V, 47M, Elect.
C770,C780	374724734	0.047 $\mu$ F $\pm$ 5%, 50V, Plastic
C776,C781	356724709R2	CEWX6.3V, 47M, C-Elect.
C788,C789	356724709R2	CEWX6.3V, 47M, C-Elect.
C793	356724709R2	CEWX6.3V, 47M, C-Elect.
C804~C806	356724709R2	CEWX6.3V, 47M, C-Elect.

CIRCUIT NO.	PART NO.	DESCRIPTION
<b>Capacitors</b>		
C810~C812	356724709R2	CEWX6.3V, 47M, C-Elect.
C816~C818	356724709R2	CEWX6.3V, 47M, C-Elect.
C821~C826	356780229R2	CEWX50V, 2.2M, C-Elect.
C893~C895	356741009R2	CEWX16V, 10M, C-Elect.
<b>Plug</b>		
P804	25055236	NPLG-5P220
<b>Sockets</b>		
JL801b,JL802b	25050286	NSCT-9P114

**AC-3 TERMINAL PC BOARD (NADG-5806-1A/1B/1C/1D/1E)**

CIRCUIT NO.	PART NO.	DESCRIPTION
U121	24120037	TORX178A, Photo coupler
L121	233454M022	NCH-1452-022M, Choke coil
L122	232136	NSRF-2046,Coil
C1115	374721044	0.1 $\mu$ F $\pm$ 5%, 50V, Plastic capacitor
C1116	375524744	0.47 $\mu$ F $\pm$ 5%, 50V, Plastic capacitor
P101	25045477	NPJ-1PDBL295, Terminal
P102	25045478	NPJ-1PDBL296, Terminal
P804	2009990434	NSAS-10P0578, Socket

**FRONT AND CENTER MAIN AMP. PC BOARD (NAAF-5809-1A/1B/1D/1E)**

CIRCUIT NO.	PART NO.	DESCRIPTION
<b>Transistors</b>		
Q1501,Q1502	2211733	2SC1845-E
Q1503	2212115 or 2213284	2SC2458-GR or 2SC1740S-R
Q1504~Q1506	2211353 or 2211354	2SA949-O or 2SA949-Y
Q1507,Q1517	2211633 or 2211634	2SC2229-O or 2SC2229-Y
Q1508	2212653 or 2212654	2SC3421-O or 2SC3421-Y
Q1509	2212653 or 2212654	2SC3421-O or 2SC3421-Y
Q1510	2212643 or 2212644	2SA1358-O or 2SA1358-Y
Q1515	2212864	2SC3419-Y
Q1518	2211733	2SC1845-E
Q501,Q502	2211733	2SC1845-E
Q503,Q603	2212115 or 2213284	2SC2458-GR or 2SC1740S-R
Q504~Q506	2211353 or 2211354	2SA949-O or 2SA949-Y
Q604~Q606	2211633 or 2211634	2SC2229-O or 2SC2229-Y
Q507,Q607	2211633 or 2211634	2SC2229-O or 2SC2229-Y
Q517,Q617	2211634	2SC2229-Y
Q508,Q608	2212653 or 2212654	2SC3421-O or 2SC3421-Y
Q509,Q609	2212654	2SC3421-Y
Q510,Q610	2212643 or 2212864	2SA1358-O or 2SC3419-Y
Q515,Q615	2212864	2SC3419-Y
Q518,Q618	2211733	2SC1845-E
Q541,Q542	2213284 or 2212115	2SC1740S-R or 2SC2458-GR
Q601,Q602	2211733	2SC1845-E
Q961	2211733	2SC1845-E
Q962,Q965	2211792 or 2211793	2SA992-F or 2SA992-E
Q964	2211733	2SC1845-E
Q991,Q992	2213284 or 2212115	2SC1740S-R or 2SC2458-GR

# PRINTED CIRCUIT BOARD-PARTS LIST

CIRCUIT NO.	PART NO.	DESCRIPTION	CIRCUIT NO.	PART NO.	DESCRIPTION
	<b>Diodes</b>			<b>Sockets</b>	
D1501	223163,	1SS133,	JL501b	25050268	NSCT-4P96
D501,D601	223222 or	WG713A or	JL911a	25051110	NSCT-6P897
D961,D971	223205	1SS270A	JL941a	25050271	NSCT-7P99
D991,D992	223163,	1SS133,	P511	2009990382	NSAS-10P0519
	223222 or	WG713A or		<b>Radiators</b>	
	223205	1SS270A	Q1508a	27160374	
	<b>Cores</b>		Q508a,Q609a	27160374	
L1501,L1502	5597-45502			<b>Screws</b>	
L501,L502	5597-45502		Q1508b	838430107	3TTB+10S(BC),Self-tapping
L601,L602	5597-45502				
	<b>Capacitors</b>				
C1502	354781009	10 $\mu$ F,50V, Elect.	<b>TRANSISTOR TERMINAL PC BOARD (NAETC-5810-1A/1B/1D/1E)</b>		
C1505	354742219	220 $\mu$ F,16V, Elect.	<b>CIRCUIT NO.</b>	<b>PART NO.</b>	<b>DESCRIPTION</b>
C1509	374721015	100pF $\pm$ 10%, 50V, Plastic	Q511	2203000	2SA1930,Transistor
C1514	354764709	47 $\mu$ F,35V, Elect.	Q512	2203010	2SC5171,Transistor
C1517	374721044	0.1 $\mu$ F $\pm$ 5%, 50V, Plastic	Q513	2203073 or	* 2SA1987-O or
C1521,C1522	354700109	1 $\mu$ F,160V, Elect.		2203072	* 2SA1987-R,Transistor
C1525	374723315	330pF $\pm$ 10%, 50V, Plastic	Q514	2203083 or	* 2SC5359-O or
C502,C602	354781009	10 $\mu$ F,50V, Elect.		2203082	* 2SC5359-R,Transistor
C505,C605	354742219	220 $\mu$ F,16V, Elect.	P521	25055331	NPLG-6P314, Plug
C509,C609	374721015	100pF $\pm$ 10%, 50V, Plastic	P522,P523	25055329	NPLG-4P312, Plug
C514,C614	354764709	47 $\mu$ F,35V, Elect.	P524	25055330	NPLG-5P313, Plug
C517,C617	374721044	0.1 $\mu$ F $\pm$ 5%, 50V, Plastic			
C521,C522	354700109	1 $\mu$ F,160V, Elect.			
C525,C625	374723315	330pF $\pm$ 10%, 50V, Plastic	<b>TRANSISTOR TERMINAL PC BOARD (NAETC-5811-1A/1B/1D/1E)</b>		
C541	354722219	220 $\mu$ F,6.3V, Elect.	<b>CIRCUIT NO.</b>	<b>PART NO.</b>	<b>DESCRIPTION</b>
C621,C622	354700109	1 $\mu$ F,160V, Elect.	Q611	2203000	2SA1930,Transistor
C911,C912	374731044	0.1 $\mu$ F $\pm$ 5%, 100V, Plastic	Q612	2203010	2SC5171,Transistor
C913,C914	3504259	12000 $\mu$ F,71V, Elect.	Q613	2203073 or	* 2SA1987-O or
C961,C971	354744709	47 $\mu$ F,16V, Elect.		2203072	* 2SA1987-R,Transistor
	<b>Resistors</b>		Q614	2203083 or	* 2SC5359-O or
R1513,R1514	4500093	82 $\Omega$ $\pm$ 5%, 1/4W, Metal		2203082	* 2SC5359-R,Transistor
R1515	443526804	68 $\Omega$ $\pm$ 5%, 1/2W, Metal oxide	D911	22380279	△ RS804, Rectifier diode
R1516,R1517	4500093	82 $\Omega$ $\pm$ 5%, 1/4W, Metal	P516	25055330	NPLG-5P313, Plug
R1522	5210285	N06HR680BE, Trimming	P517	25055329	NPLG-4P312, Plug
R1528,R1531	4500101	180 $\Omega$ $\pm$ 5%, 1/4W, Metal	P518	25055332	NPLG-7P315, Plug
R1532,R1533	4500083	33 $\Omega$ $\pm$ 5%, 1/4W, Metal	P519	25055328	NPLG-3P311, Plug
R1538,R1539	4000116	MPC74-5WK, 0.1, Metal plate	P520	25055333	NPLG-8P316, Plug
R1540	453630824	8.2 $\Omega$ $\pm$ 5%, 1W, Metal			
R1545,R1546	4500055	2.2 $\Omega$ $\pm$ 5%, 1/4W, Metal	<b>TRANSISTOR TERMINAL PC BOARD (NAETC-5812-1A/1B/1D/1E)</b>		
R513,R514	4500093	82 $\Omega$ $\pm$ 5%, 1/4W, Metal	<b>CIRCUIT NO.</b>	<b>PART NO.</b>	<b>DESCRIPTION</b>
R515,R615	443526804	68 $\Omega$ $\pm$ 5%, 1/2W, Metal oxide	Q1511	2203000	2SA1930,Transistor
R516,R517	4500093	82 $\Omega$ $\pm$ 5%, 1/4W, Metal	Q1512	2203010	2SC5171,Transistor
R522,R622	5210285	N06HR680BE, Trimming	Q1513	2203073 or	* 2SA1987-O or
R528,R531	4500101	180 $\Omega$ $\pm$ 5%, 1/4W, Metal		2203072	* 2SA1987-R,Transistor
R532,R533	4500083	33 $\Omega$ $\pm$ 5%, 1/4W, Metal	Q1514	2203083 or	* 2SC5359-O or
R538,R539	4000116	MPC74-5WK, 0.1, Metal plate		2203082	* 2SC5359-R,Transistor
R540,R640	453630824	8.2 $\Omega$ $\pm$ 5%, 1W, Metal	P512,P515	25055330	NPLG-5P313, Plug
R545,R546	4500055	2.2 $\Omega$ $\pm$ 5%, 1/4W, Metal	P513,P514	25055329	NPLG-4P312, Plug
R547,R647	443623914	390 $\Omega$ $\pm$ 5%, 1W, Metal oxide			
R613,R614	4500093	82 $\Omega$ $\pm$ 5%, 1/4W, Metal	<b>BIAS TRANSISTOR PC BOARD (NAETC-5813-1A/1B/1D/1E)</b>		
R616,R617	4500093	82 $\Omega$ $\pm$ 5%, 1/4W, Metal	<b>CIRCUIT NO.</b>	<b>PART NO.</b>	<b>DESCRIPTION</b>
R622	5210285	N06HR680BE, Trimming	Q1516	2211733	2SC1845-E,Transistor
R628,R631	4500101	180 $\Omega$ $\pm$ 5%, 1/4W, Metal	Q516,Q616	2211733	2SC1845-E,Transistor
R632,R633	4500083	33 $\Omega$ $\pm$ 5%, 1/4W, Metal	P504*P506	2009990422	NSAS-4P0566, Socket
R638,R639	4000116	MPC74-5WK, 0.1, Metal plate			
R645,R646	4500055	2.2 $\Omega$ $\pm$ 5%, 1/4W, Metal	<b>HEADPHONE TERMINAL PC BOARD (NAAF-5801-1A/1B/1C)</b>		
	<b>Relays</b>		<b>CIRCUIT NO.</b>	<b>PART NO.</b>	<b>DESCRIPTION</b>
RL501,RL502	25065510 or 25065517	NRL-2P5A-DC24V-095 or NRL-2P5A-DC24-098	JL503a	25051089	NSCT-5P876, Socket
	<b>Plugs</b>		P503	25045385	YKB26-5153, Terminal
JL503b	25055626	NPLG-5P588			
P507*P509	25055038	NPLG-2P29			

**AC OUTLET TERMINAL PC BOARD (NAETC-5819-1A/5822-1B/1E)**

CIRCUIT NO.	PART NO.	DESCRIPTION
P902	25051220	NSCT-6P1010, AC OUTLET <D>
P903	25051125	NSCT-4P912, AC OUTLET <P/PB/PT/W/K>

**POWER SUPPLY CIRCUIT PC BOARD (NAPS-5821-1A/5822-1B/1E)**

CIRCUIT NO.	PART NO.	DESCRIPTION
<b>Diodes</b>		
D951	22380260,	RL1N4003,
	22380035 or	GP104003E or
	22380046	AM01Z
D955	223163,	1SS133,
	223222 or	WG713A or
	223205	1SS270A <D/W/K>
<b>Transformer</b>		
T902	2300670	NPT-1111D, Power <D>
	2300671	NPT-1111P, Power <P/PB/PT>
	2300672	NPT-1111DG, Power <W/K>
<b>Capacitors</b>		
C901	3500191	△ DE7150F-103M, IS
C952	354742219	220 $\mu$ F, 16V, Elect.
<b>Resistor</b>		
R901	431533355	△ RC1/2GFK, 3.3M, Solid <D>
R951	453530824	8.2 $\Omega$ $\pm$ 5%, 1/2W, Metal
<b>Relay</b>		
RL901	25065248 or	NRL-1P15A-DC12V-29 or
	25065516	NRL-1P10A-DC12-097 <D/K>
	25065515 or	NRL-1P5A-DC12-096 or
	25065508	NRL-1P10A-DC12-093 <P/PB/PT/W>
<b>Fuses</b>		
F901	252155	△ 10A-TSC <D/W>
F902	252078	△ 5A-SE-EAK <P/PB/PT/W/K>
F903	252075	△ 2.5A-SE-EAK <P/PB>
<b>Holders</b>		
F901a	25050065	△ YSH403T, Fuse <D/W>
F902a	25050065	△ YSH403T, Fuse <P/PB/PT/W/K>
F903a	25050065	△ YSH403T, Fuse <P/PB>
<b>Plugs</b>		
JL942a	25055624	NPLG-3P586
P901a	25055675	NPLG-2P631

**SECONDARY CIRCUIT PC BOARD (NAPS-5824-1A/1B/1D/1E)**

CIRCUIT NO.	PART NO.	DESCRIPTION
F915a,F916a	25050065	△ YSH403T, Fuseholder
F915,F916	252153	△ 6.3A-TSC, Fuse <D>
	252079	△ 6.3A-SE-EAK, Fuse <P/W/K>
JL911b	25050270	NSCT-6P98, Socket
JL912b	25050267	NSCT-3P95, Socket
JL921b	25050281	NSCT-4P109, Socket
R921,R922	453532294	0.22 $\Omega$ $\pm$ 5%, 1/2W, Metal resistor
R948	453530104	1 $\Omega$ $\pm$ 5%, 1/2W, Metal resistor
R929	453632294	0.22 $\Omega$ $\pm$ 5%, 1W, Metal resistor

**SPEAKER TERMINAL PC BOARD (NAETC-5825-1A/1B/1D/1E)**

CIRCUIT NO.	PART NO.	DESCRIPTION
<b>Terminals</b>		
P501	25060147	NTM-4PDMN075, Speaker
P502	25060235	NTM-6PDMN157, Speaker

**CAUTION: Replacement for transistor of mark \*, if necessary, must be made from the same beta group (H FE) as the original type.**

**NOTE: THE COMPONENTS IDENTIFIED BY MARK △ ARE CRITICAL FOR RISK OF FIRE AND ELECTRIC SHOCK. REPLACE ONLY WITH PART NUMBER SPECIFIED.**

NOTE: <D>: 120V model only      <PT>: Asian model only  
 <P>: 230V model only      <PB>: U.K. model only  
 <W>: Worldwide model only  
 <K>: Korean model only

A B C D E F G

**SCHEMATIC DIAGRAM**

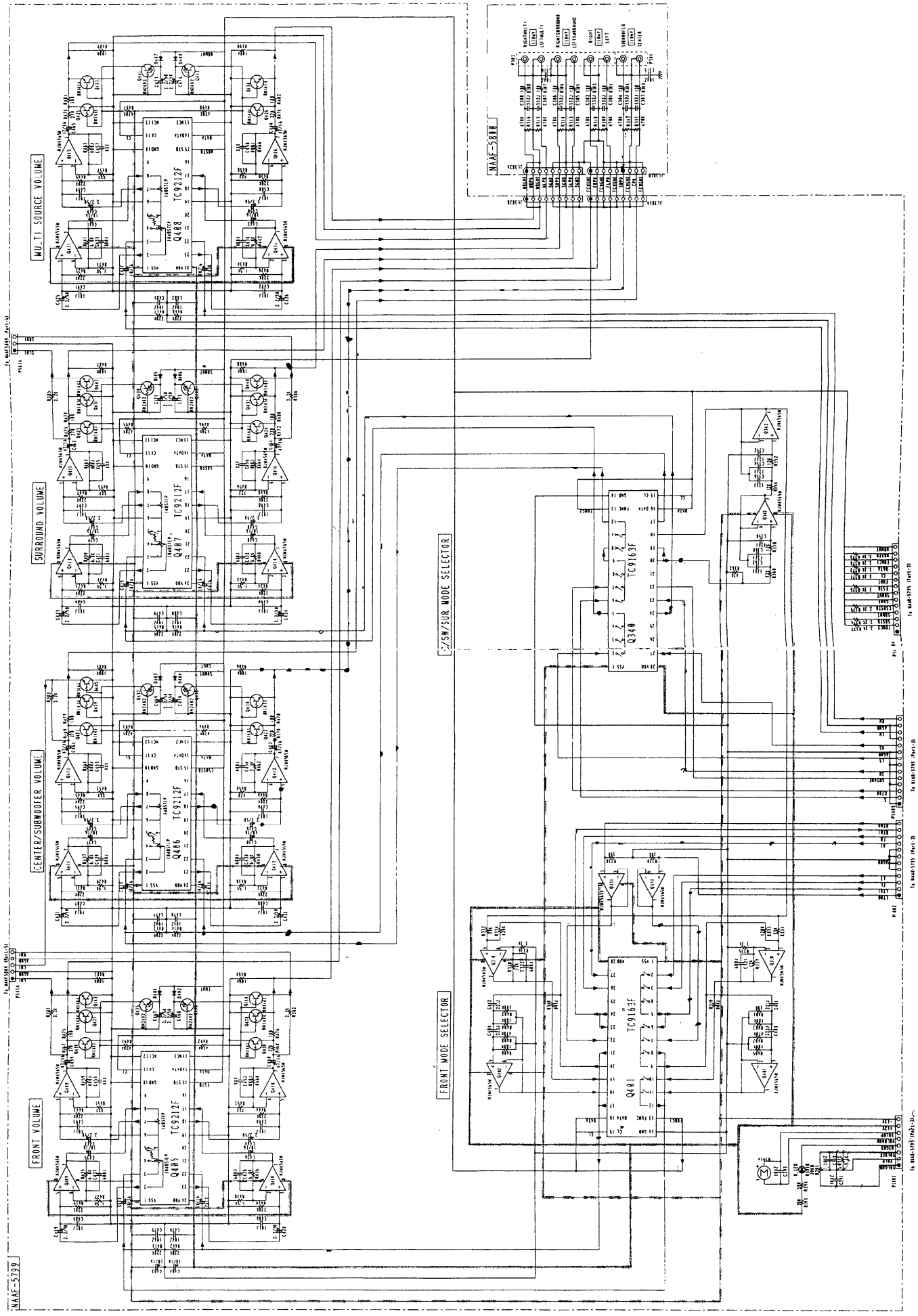

## PRINTED CIRCUIT BOARD-PARTS

### VOLUME CIRCUIT PC BOARD (NAAF-5799-1A/1B/1C)

CIRCUIT NO.	PART NO.	DESCRIPTION
	<b>ICs</b>	
Q330,Q331	22240581R1	NJM4565M
Q340	22240943R2	TC9163AF
Q342	22240581R1	NJM4565M
Q401	22240943R2	TC9163AF
Q402	22240581R1	NJM4565M
Q405~Q408	22240944R2	TC9212F
Q409~Q416	22240581R1	NJM4565M
	<b>Transistors</b>	
Q419~Q434	2215410R2	RN1441
Q435~Q442	2214530R2	RN2402
Q443~Q445	2215410R2	RN1441
Q447,Q448	2215410R2	RN1441
	<b>Diodes</b>	
D401~D408	223234R2	1SS352
	<b>Capacitors</b>	
C352,C354	374721244	0.12 $\mu$ F $\pm$ 5%, 50V, Plastic
C356,C358	374721244	0.12 $\mu$ F $\pm$ 5%, 50V, Plastic
C360,C362	374721244	0.12 $\mu$ F $\pm$ 5%, 50V, Plastic
C401~C404	374722234	0.022 $\mu$ F $\pm$ 5%, 50V, Plastic
C411~C418	354741009	10 $\mu$ F, 16V, Elect.
C419~C426	354780229	2.2 $\mu$ F, 50V, Elect.
C435~C442	354741009	10 $\mu$ F, 16V, Elect.
C443~C450	354780229	2.2 $\mu$ F, 50V, Elect.
C459~C466	354744709	47 $\mu$ F, 16V, Elect.
C467~C474	354780229	2.2 $\mu$ F, 50V, Elect.
C483,C484	354741009	10 $\mu$ F, 16V, Elect.
	<b>Resistor</b>	
R391	5142017	N16RGL20KB25F, Variable
	<b>Plugs</b>	
P561a	25055133	NPLG-3P11
P511a	25055135	NPLG-5P119
	<b>Sockets</b>	
JL381a,JL382b	25051093	NSCT-9P880
P1401	25050983	NSCT-8P770
P1402	25050985	NSCT-12P772
P1403,P1404	25050986	NSCT-14P773

### PRE., OUTPUT PC BOARD (NAAF-5800-1A/1B/1C)

CIRCUIT NO.	PART NO.	DESCRIPTION
C301~C308	374723324	3300pF $\pm$ 5%, 50V, Plastic capacitor
JL381b,JL382a	25051093	NSCT-9P880, Socket
P301	25045357	NPJ-2PDBL203, Terminal
P302	25045480	NPJ-6PDBL298, Terminal

SCHEMATIC DIAGRAM

A B C D E F G

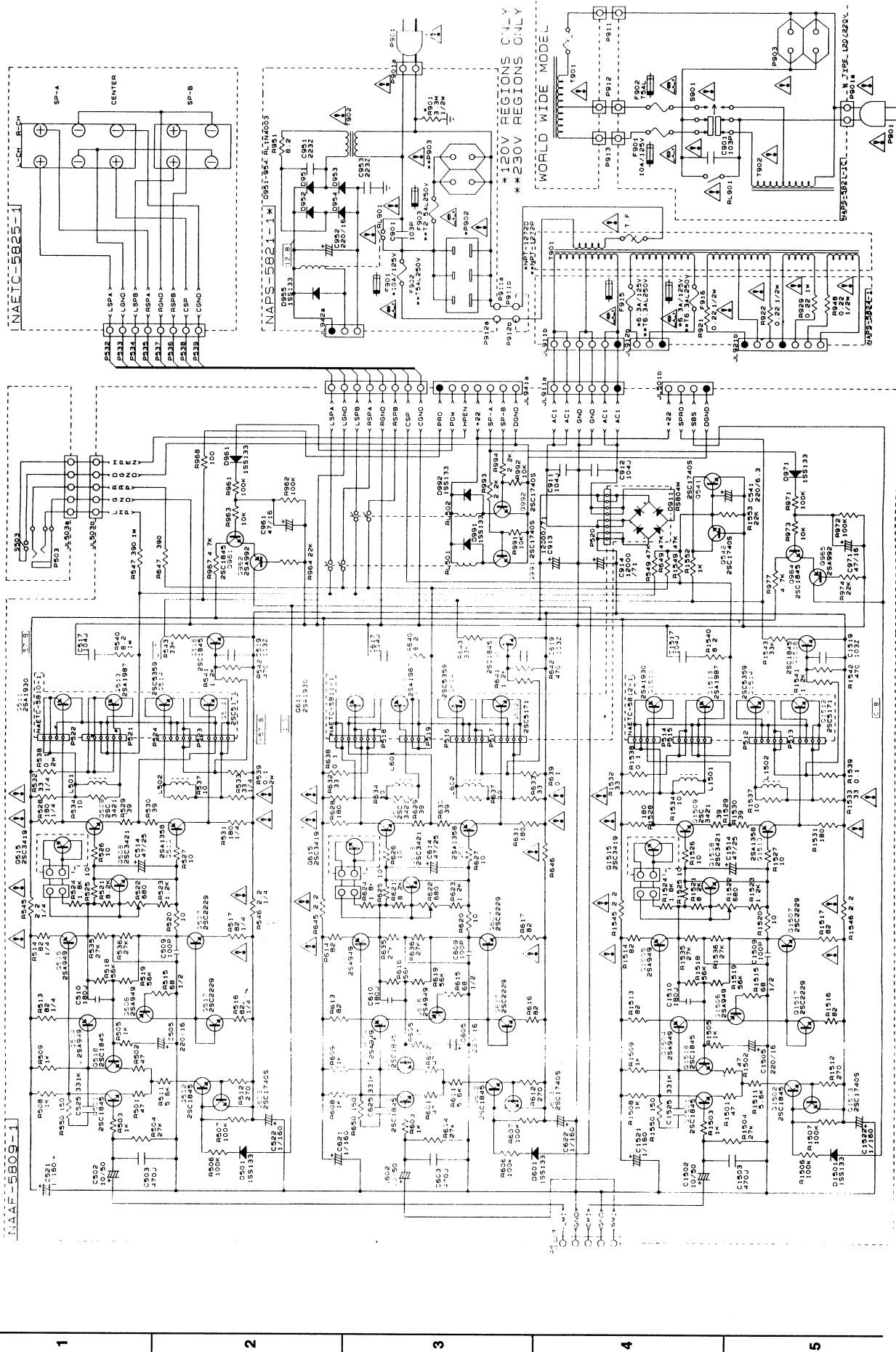

SCHEMATIC DIAGRAM

A B C D E F G

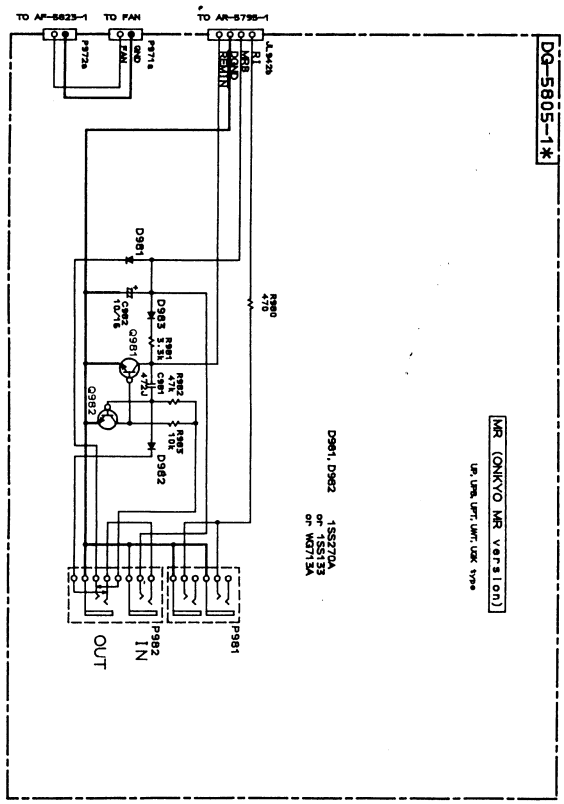
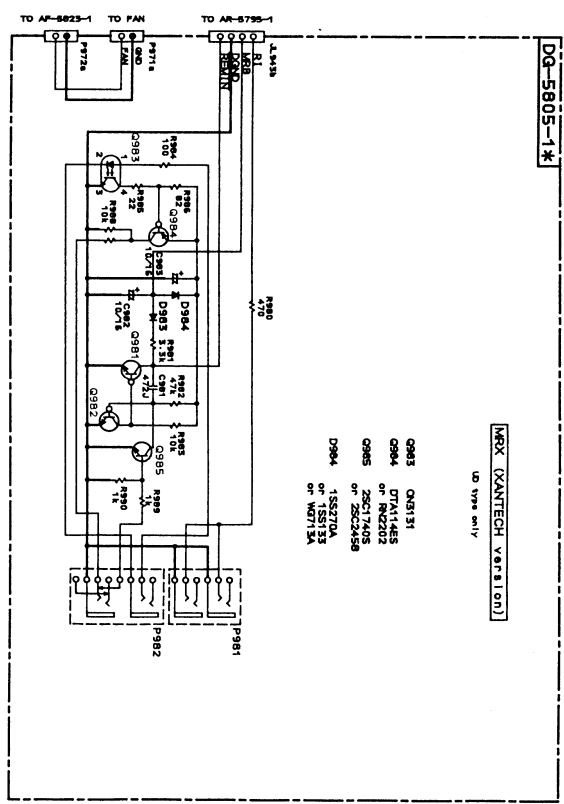
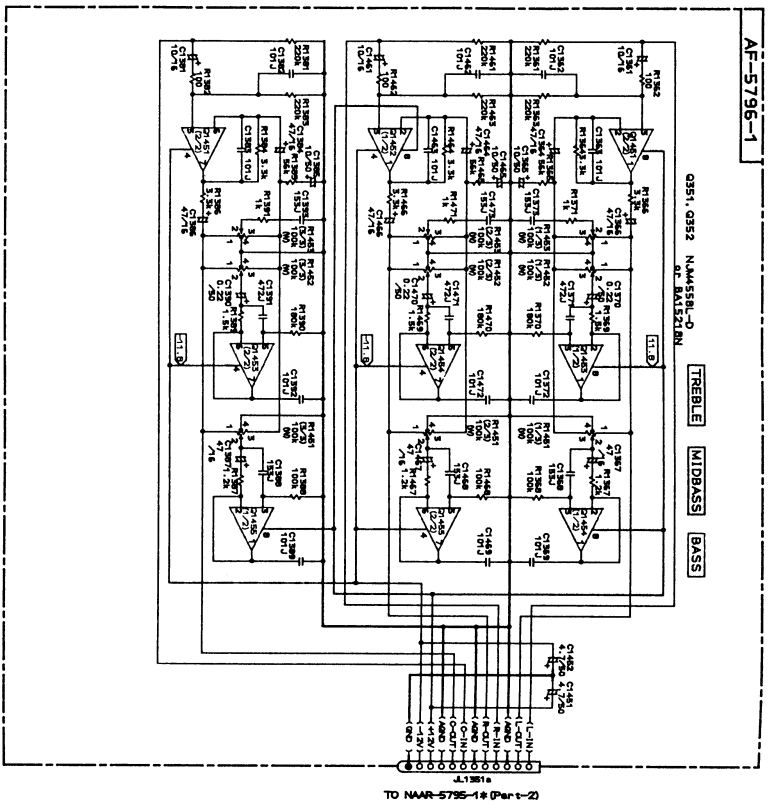

1 2 3 4 5



## PRINTED CIRCUIT BOARD-PARTS LIST

### TONE CONTROL CIRCUIT PC BOARD (NAAF-5796-1A/1B/1C/1D/1E)

CIRCUIT NO.	PART NO.	DESCRIPTION
	<b>ICs</b>	
Q1451~Q1455	22240293 or 22240247	NJM4558L-D or BA15218N
	<b>Capacitors</b>	
C1361,C1381	354741009	10 $\mu$ F,16V, Elect.
C1364,C1366	354744709	47 $\mu$ F,16V, Elect.
C1365,C1385	354741009	10 $\mu$ F,16V, Elect.
C1367,C1384	354744709	47 $\mu$ F,16V, Elect.
C1368,C1373	374721534	0.015 $\mu$ F $\pm$ 5%, 50V, Plastic
C1370,C1390	354782299	0.22 $\mu$ F,50V, Elect.
C1371,C1391	374724724	4700pF $\pm$ 5%, 50V, Plastic
C1386,C1387	354744709	47 $\mu$ F,16V, Elect.
C1388,C1393	374721534	0.015 $\mu$ F $\pm$ 5%, 50V, Plastic
C1451,C1452	354780479	4.7 $\mu$ F,50V, Elect.
C1461,C1465	354741009	10 $\mu$ F,16V, Elect.
C1464,C1466	354744709	47 $\mu$ F,16V, Elect.
C1467	354744709	47 $\mu$ F,16V, Elect.
C1468,C1473	374721534	0.015 $\mu$ F $\pm$ 5%, 50V, Plastic
C1470	354782299	0.22 $\mu$ F,50V, Elect.
C1471	374724724	4700pF $\pm$ 5%, 50V, Plastic
	<b>Resistors</b>	
R1451~R1453	5104386	N9RTL100KWT-25F, Variable
	<b>Socket</b>	
JL1351	25051096	NSCT-12P883

### RI/MR TERMINAL PC BOARD (NADG-5805-1A/1B/1C/1D/1E)

CIRCUIT NO.	PART NO.	DESCRIPTION
	<b>Transistors</b>	
Q981,Q982	221282 or 2213560	DTC144ES or RN1204
Q984	2213510 or 2214350	DTA114ES or RN2202 <D>
Q985	2213284 or 2212115	2SC1740S-R or 2SC2458-GR <D>
	<b>Photo coupler</b>	
Q983	24120043	ON3131 <D>
	<b>Diodes</b>	
D981,D982	223163, 223222 or 223205	1SS133, WG713A or 1SS270A <P/PT/PB/W/K>
D983	223163, 223222 or 223205	1SS133, WG713A or 1SS270A
D984	223163, 223222 or 223205	1SS133, WG713A or 1SS270A <D>
	<b>Capacitors</b>	
C981	374724724	4700pF $\pm$ 5%, 50V, Plastic
C982	354741009	10 $\mu$ F,16V, Elect.
C983	354741009	10 $\mu$ F,16V, Elect. <D>
	<b>Plugs</b>	
JL943b	25055625	NPLG-4P587
P971a	25055600	NPLG-2P568
P972a	25055366	NPLG-2P349
	<b>Terminals</b>	
P981	25045433	HSJ-1003-01-013 <D>
	25045293	HSJ-1003-01-012 <P/PT/PB/W/K>
P982	25045172	HSJ-1003-01-020

## PRINTED CIRCUIT BOARD-PARTS LIST

### SURROUND AMPLIFIER PC BOARD (NAAF-5817-1A/1B/1D/1E)

CIRCUIT NO.	PART NO.	DESCRIPTION
	<b>Transistors</b>	
Q551,Q651	2215427	2SC5169-G
Q552,Q652	2211733	2SC1845-E
Q553,Q653	2213284 or 2212115	2SC1740S-R or 2SC2458-GR
Q554~Q556 Q654~Q656	2211354 or 2211353	2SA949-Y or 2SA949-O
Q557,Q657	2211634 or 2211633	2SC2229-Y or 2SC2229-O
Q558,Q658	2212654 or 2212653	* 2SC3421-Y or * 2SC3421-O
Q561,Q661	2203010	2SC5171
Q562,Q662	2203000	2SA1930
Q565,Q665	2211634 or 2211633	2SC2229-Y or 2SC2229-O
Q566,Q666	2211793 or 2211792	2SA992-E or 2SA992-F
Q567,Q667	2211733	2SC1845-E
Q591,Q592	2213284 or 2212115	2SC1740S-R or 2SC2458-GR
Q594	2212445	2SK365-GR
Q593	2212644 or 2212643	2SA1358-Y or 2SA1358-O
	<b>Diodes</b>	
D551,D591	223163,	1SS133,
D651,D691	223222 or 223205	WG713A or 1SS270A
	<b>Capacitors</b>	
C552,C652	354780479	4.7 $\mu$ F,50V, Elect.
C555,C655	354742219	220 $\mu$ F,16V, Elect.
C564,C665	354764709	47 $\mu$ F,35V, Elect.
C566,C666	374721044	0.1 $\mu$ F $\pm$ 5%, 50V, Plastic
C571,C572	354784709	47 $\mu$ F,50V, Elect.
C576,C676	374721024	1000pF $\pm$ 5%, 50V, Plastic
C591	354722219	220 $\mu$ F,6.3V, Elect.
C593	354764709	47 $\mu$ F,35V, Elect. <D>
C594	354781009	10 $\mu$ F,50V, Elect.
C664,C665	354764709	47 $\mu$ F,35V, Elect.
C671,C672	354784709	47 $\mu$ F,50V, Elect.
C915,C916	374731044	0.1 $\mu$ F $\pm$ 5%, 100V, Plastic
C917,C918	3504272	6800 $\mu$ F,50V, Elect.
	<b>Resistors</b>	
R1574	4400021	120 $\Omega$ $\pm$ 5%, 2W, Metal oxide
R563,R564	443526804	68 $\Omega$ $\pm$ 5%, 1/2W, Metal oxide
R566,R567	443526804	68 $\Omega$ $\pm$ 5%, 1/2W, Metal oxide
R573,R673	443521014	100 $\Omega$ $\pm$ 5%, 1/2W, Metal oxide
R574,R575	453530224	2.2 $\Omega$ $\pm$ 5%, 1/2W, Metal
R576,R676	453630824	8.2 $\Omega$ $\pm$ 5%, 1W, Metal
R582,R682	4500031	MPC722-5WK-0.22, Metal plate
R583,R683	443523924	3.9k $\Omega$ $\pm$ 5%, 1/2W, Metal oxide
R588,R589	453530224	2.2 $\Omega$ $\pm$ 5%, 1/2W, Metal
R663,R664	443526804	68 $\Omega$ $\pm$ 5%, 1/2W, Metal oxide
R666,R667	443526804	68 $\Omega$ $\pm$ 5%, 1/2W, Metal oxide
R674,R675	453530224	2.2 $\Omega$ $\pm$ 5%, 1/2W, Metal
R688,R689	453530224	2.2 $\Omega$ $\pm$ 5%, 1/2W, Metal
	<b>Sockets</b>	
JL501a	25051108	NSCT-4P895
JL552a	25051109	NSCT-5P896
JL912a	25051107	NSCT-3P894
P561	2009990241A	NSAS-6P0346
P571,P671	2009990439	NSAS-4P0583
P913	2009990419	NSAS-4P0563

### TRANSISTOR TERMINAL PC BOARD (NAETC-5818-1A/1B/1D/1E)

CIRCUIT NO.	PART NO.	DESCRIPTION
Q563,Q663	2203063 or 2203062	* 2SC5198-O or * 2SC5198-R,transistor
Q564,Q664	2203053 or 2203052	* 2SA1941-O or * 2SA1941-R, Transistor
D915	22380274, 22380038 or 22380070	$\Delta$ RS603M, $\Delta$ RBV602 or $\Delta$ D5SBA60, Rectifier diode
P562~P564	25055330	NPLG-5P313, Plug
P565,P566	25055331	NPLG-6P314, Plug
P567	25055330	NPLG-5P313, Plug

### SPEAKER TERMINAL PC BOARD (NAETC-5826-1A/1B/1D/1E)

CIRCUIT NO.	PART NO.	DESCRIPTION
JL552b	25050269	NSCT-5P97, Socket
P551	25060147	NTM-4PDMN075, Speaker terminal
C955	354741019	100 $\mu$ F,16V, Elect. capacitor <P/PB/PT>
P525	2009990431	NSAS-4P0575, Socket

NOTE: <D>:120V model only <PT>:Asian model only  
<P>:230V model only <PB>: U.K. model only  
<W>:Worldwide model only  
<K>: Korean model only



SCHEMATIC DIAGRAM

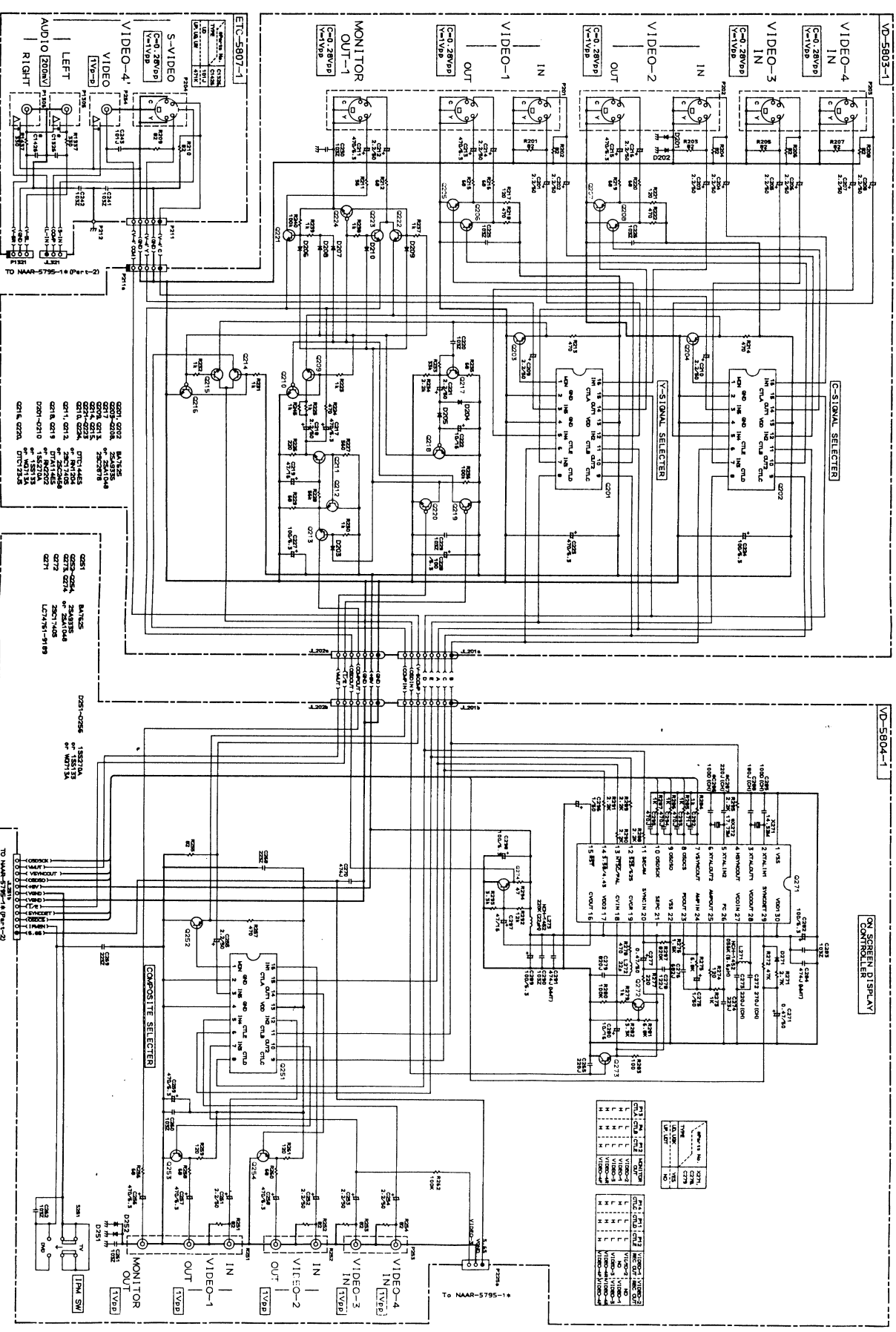

## PRINTED CIRCUIT BOARD-PARTS LIST

### S VIDEO CIRCUIT PC BOARD (NAVD-5803-1A/1B/1C/1D/1E)

CIRCUIT NO.	PART NO.	DESCRIPTION
Q201,Q202	ICs 22240373	BA7625
	<b>Transistors</b>	
Q203~Q208	2213354 or	2SA933S-R or
Q217	2212125	2SA1048-GR
Q209	2212286 or	2SC2878-B or
Q213~Q215	2212285	2SC2878-A
Q210,Q224	221282 or	DTC144ES or
	2213560	RN1204
Q211,Q212	2213284 or	2SC1740S-R or
	2212115	2SC2458-GR
Q216	2213640	DTC123JS
Q218,Q219	2213510 or	DTA114ES or
	2214350	RN2202
Q220	2213640	DTC123JS
Q221~Q223	2212286 or	2SC2878-B or
	2212285	2SC2878-A
	<b>Diode</b>	
D201~D210	223163,	1SS133,
	223222 or	WG713A or
	223205	1SS270A
	<b>Capacitors</b>	
C201~C210	354780229	2.2 $\mu$ F,50V, Elect.
C211,C213	354724719	470 $\mu$ F,6.3V, Elect.
C212,C214	354780229	2.2 $\mu$ F,50V, Elect.
C215,C217	354724719	470 $\mu$ F,6.3V, Elect.
C216,C218	354780229	2.2 $\mu$ F,50V, Elect.
C219	354744709	47 $\mu$ F,16V, Elect.
C221	354780229	2.2 $\mu$ F,50V, Elect.
C222	354741009	10 $\mu$ F,16V, Elect.
C223	354724719	470 $\mu$ F,6.3V, Elect.
C224,C227	354721019	100 $\mu$ F,6.3V, Elect.
C228	354721019	100 $\mu$ F,6.3V, Elect.
	<b>Sockets</b>	
P201	25051568	NSCT-12P1355
P202,P203	25051748	NSCT-8P1535
JL201a	25051092	NSCT-8P879
JL202a	25051091	NSCT-7P878

### VIDEO 4 TERMINAL PC BOARD (NAETC-5807-1A/1B/1C/1D/1E)

CIRCUIT NO.	PART NO.	DESCRIPTION
P204	25051749	NSCT-4P1536, Socket
P211	2009990433	NSAS-10P0577, Socket
P211a	25055135	NPLG-5P119, Plug
P254	25045479A	NPJ-1PDBL297,Terminal
P1305,P1306	25045479A	NPJ-1PDBL297,Terminal
P1321	2009990432A	NSAS-6P0576, Socket
JL321a	25051087	NSCT-3P874, Socket

### ON SCREEN CIRCUIT PC BOARD (NAVD-5804-1A/1B/1C/1D/1E)

CIRCUIT NO.	PART NO.	DESCRIPTION
Q251	ICs 22240373	BA7625
Q271	22241037	LC74761-9189
	<b>Transistors</b>	
Q252~Q254	2213354 or	2SA933S-R or
Q273,Q274	2212125	2SA1048-GR
Q272	2213284	2SC1740S-R
	<b>Diodes</b>	
D251,D252	223163,	1SS133,
D271	223222 or	WG713A or
	223205	1SS270A
	<b>Resonators</b>	
X271	3010167	XTL-14.32M, Crystal
X272	3010238	XTL-17.73M <P/PB/PT/W/K>
	<b>Coils</b>	
L271	233454K056	NCH-1452-056K, Choke
L272,L273	233454K220	NCH-1452-220K, Choke
	<b>Capacitors</b>	
C251~C255	354780229	2.2 $\mu$ F,50V, Elect.
C256~C259	354724719	470 $\mu$ F,6.3V, Elect.
C270,C284	375524744	0.47 $\mu$ F $\pm$ 5%, 50V, Plastic
C271,C277	354784799	0.47 $\mu$ F,50V, Elect.
C274	374722234	0.022 $\mu$ F $\pm$ 5%, 50V, Plastic
C275,C296	354780109	1 $\mu$ F,50V, Elect.
C280	354741009	10 $\mu$ F,16V, Elect.
C282,C289	354721019	100 $\mu$ F,6.3V, Elect.
C291	375524744	0.47 $\mu$ F $\pm$ 5%, 50V, Plastic
C297	354744709	47 $\mu$ F,16V, Elect.
C298	354721019	100 $\mu$ F,6.3V, Elect.
	<b>Switches</b>	
S251	25065286	NSS-22112
S1101	25065286	NSS-22112 <W>
	<b>Terminals</b>	
P251	25045363	NPJ-3PDYE208
P252,P253	25045319	NPJ-2PDYE176
	<b>Plugs</b>	
JL251b	25055633	NPLG-12P595
P225a	25055133	NPLG-3P117
	<b>Sockets</b>	
JL202b	25051091	NSCT-7P878
JL201b	25051092	NSCT-8P879

NOTE: <D>:120V model only <PT>:Asian model only  
 <P>:230V model only <PB>: U.K. model only  
 <W>:Worldwide model only  
 <K>: Korean model only

## DISPLAY CIRCUIT PC BOARD (NADIS-5798-1A/1B/1C)

CIRCUIT NO.	PART NO.	DESCRIPTION	CIRCUIT NO.	PART NO.	DESCRIPTION
U701	24130011	PIC-12043TE2	C702	353741009	10 $\mu$ F,16V, Elect.
	<b>Remote sensor</b>		C714,C718	375524744	0.47 $\mu$ F $\pm$ 5%, 50V, Plastic
	<b>FL tube</b>		C716	353781009	10 $\mu$ F,50V, Elect.
Q701	212153	16-BT-43GK	C717	353721019	100 $\mu$ F,6.3V, Elect.
	<b>ICs</b>		C723,C724	355741009	10 $\mu$ F,16V, Elect.
Q702	22240685R9	M66004FP	C851~C856	374723924	3900pF $\pm$ 5%, 50V, Plastic
Q851~Q853	22240581R1	NJM4565M	C857~C862	374721024	1000pF $\pm$ 5%, 50V, Plastic
	<b>Transistors</b>		C863~C874	374721824	1800pF $\pm$ 5%, 50V, Plastic
Q704,Q705	2213284 or	2SC1740S-R or	C875~C880	374723924	3900pF $\pm$ 5%, 50V, Plastic
	2212115	2SC2458-GR	C887~C892	355741009	10 $\mu$ F,16V, Elect.
Q706	2213650 or	DTD113ZS or		<b>Resistor</b>	
	2213560	RN1226	R705	49163103415	RM1/10IJ, 10K*13, Array
	<b>Diodes</b>			<b>Switches</b>	
D701,D702	225291D	SEL4910D-D, LED	S700	25035653	NPS-122-L605, P SW <P/PB>
D703,D711	223234R2	1SS352	S701	25035652	NPS-111-S604, P SW <D/W/PT>
D704	225291D	SEL4910D-D, LED	S702~S707	25035652	NPS-111-S604, Push
D705	225259	SEL2910A, LED	S709~S715	25035652	NPS-111-S604, Push
D706	223234R2	1SS352 <P/PB>	S716	25035652	NPS-111-S604, P SW <P/PB>
D712	224481302R2 or	DTZ13B or	S717~S748	25035652	NPS-111-S604, Push
	224491300R2	UDZ13B, Zener		<b>Holders</b>	
D713	223234R2	1SS352	D705a	27190498	LED-1
	<b>Coils</b>		JL701b	25050946	NSCT-40P733
L721,L722	231237K470R2	NCH-1479	JL801b,JL802b	25051113	NSCT-9P900
			Q701a	27190913Y	FL tube

NOTE: <D>:120V model only <PT>:Asian model only  
 <P>:230V model only <PB>: U.K. model only  
 <W>:Worldwide model only  
 <K>: Korean model only

**EXPLODED VIEW**

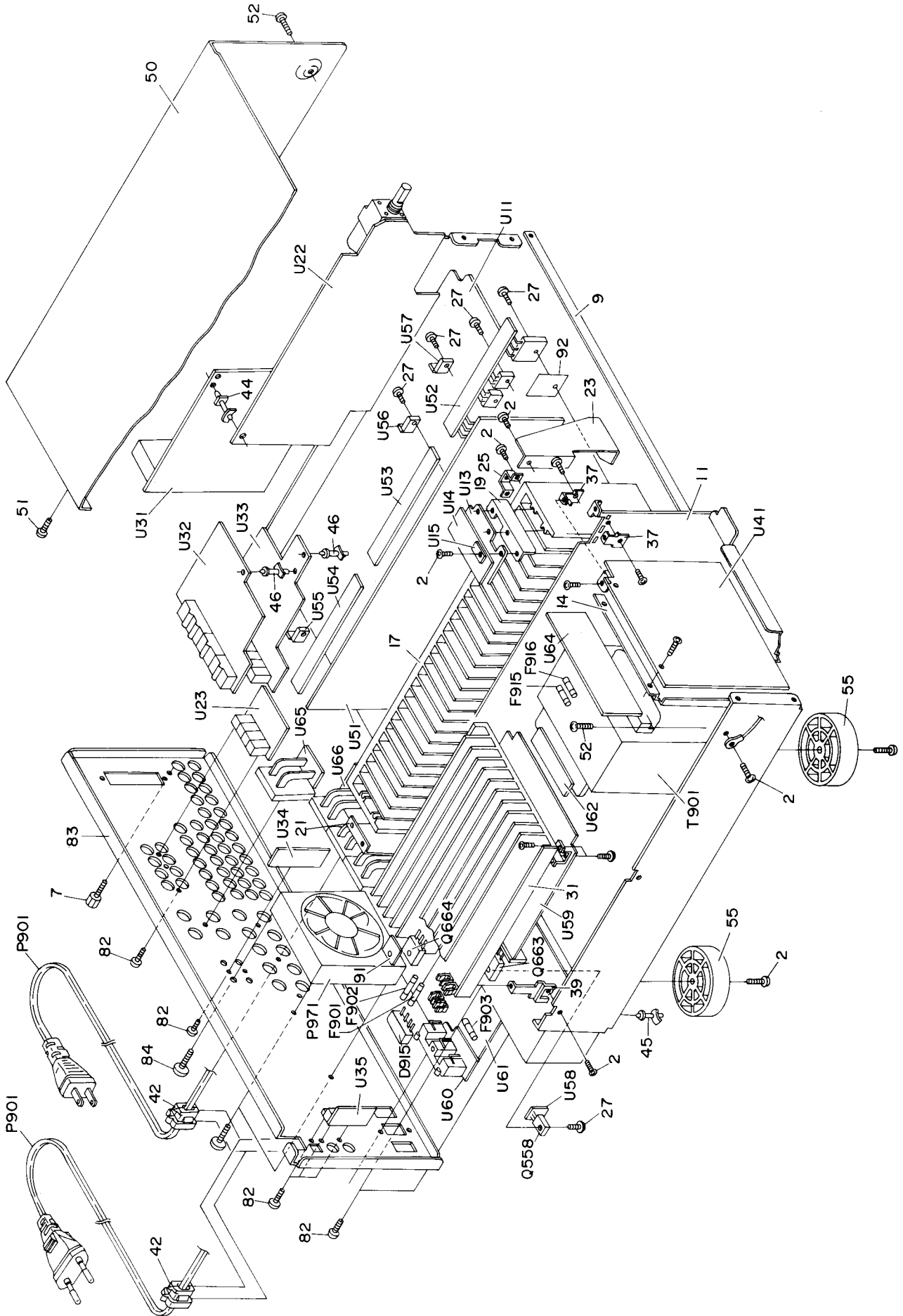

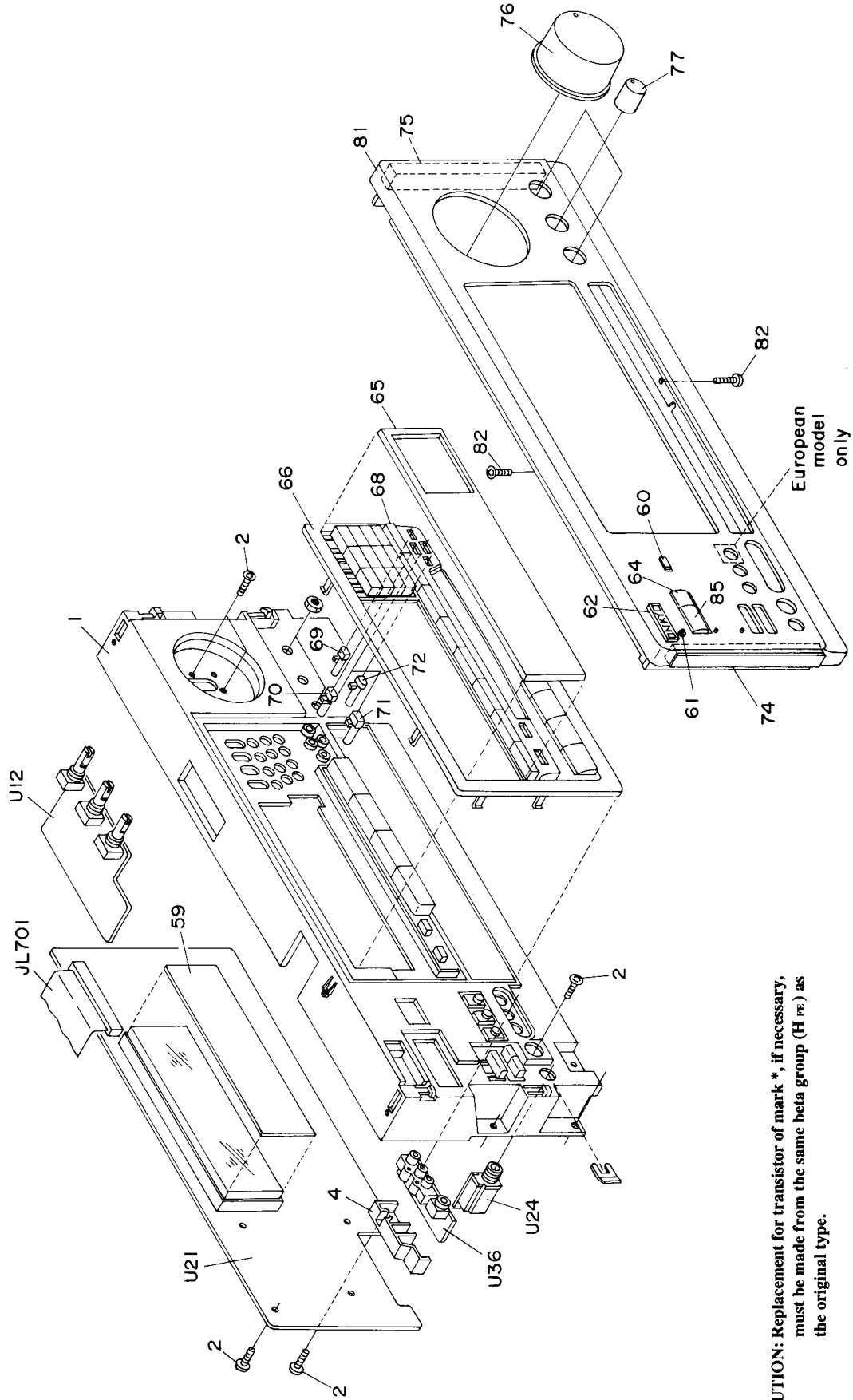

**CAUTION:** Replacement for transistor of mark \*, if necessary, must be made from the same beta group (H  $\beta$ ) as the original type.

**NOTE: THE COMPONENTS IDENTIFIED BY MARK  $\Delta$  ARE CRITICAL. FOR RISK OF FIRE AND ELECTRIC SHOCK, REPLACE ONLY WITH PART NUMBER SPECIFIED.**



# EXPLODED VIEW-PARTS LIST

REF.NO.	PART NO.	DESCRIPTION
1	27110945A	Front bracket <B>
	271110947A	Front bracket <G>
2	838130088	3TTB+8B, Self-tapping screw
4	27190982	Holder PJ
7	25060151	Ground terminal
9	27100318A	Chassis
11	27130777A	Bracket PT
13	27300833	WS-ZNS, Clamp
14	27141666	Retainer D
17	27160371A	Radiator L
19	27141663	Retainer A
21	27141664A	Retainer B
23	27141665	Retainer C
25	27141528	Retainer HL-2
27	801433	3SMS8W.SW+14B(BC),Special screw
30	27270148	Spacer
31	27160372B	Radiator S
33	27141528	Retainer HL-2
37	27141330	Retainer PC
39	27141651	Retainer TPC
40	27141333	Retainer S
42	27300750	Bushing cord
43	27190164	KGLS-14S, Holder
44	27190470	KGLS-18S, Holder
45	27190062	KGLS-12S, Holder
46	27190524	KGLS-14RF, Holder
48	830440089	4TTC+8C(BC), Self-tapping screw
50	28184657	Top cover <B>
	28184659	Top cover <G>
51	838440088	3TTB+8B(BC), Self-tapping screw
52	838440089	4TTB+8C(BC), Self-tapping screw
53	28140881	14*50*15, Cushion
54	28141305	0.8*57*8, Cushion
55	27173317	Leg
59	28133355	Back plate <B>
	28133356	Back plate <G>
60	28198854	Facet AC-3
61	28198846Y	Facet
62	28135243	Badge <B>
	28135242	Badge <G>
64	28191738Y	Clear plate RE
65	28191731A	Clear plate
66	27215267A	Decorative frame <B>
	27215269A	Decorative frame <G>
68	28325384	Knob CL <B>
	28325386	Knob CL <G>
69	28325390	Knob PRIM-1 <B>
	28325398	Knob PRIM-1 <G>
70	28325391	Knob PRIM-2 <B>
	28325399	Knob PRIM-2 <G>
71	28325392	Knob PRIM-3 <B>
	28325400	Knob PRIM-3 <G>
72	28325393	Knob PRIM-4 <B>
	28325401	Knob PRIM-4 <G>
74	28125335A	End cap L <B>
	28125339A	End cap R <B>
75	28125340A	End cap R <G>

REF.NO.	PART NO.	DESCRIPTION
76	28325402	Knob, volume <B>
	28325404	Knob, volume <G>
77	28325405	Knob, tone <B>
	28325407	Knob, tone <G>
81	27211851	Front panel <D/PT/W/K> <B>
	27211852	Front panel <P/PB> <B>
	27211853	Front panel <G>
82	838430088	3TTB+8B(BC), Self-tapping screw
83	27122244B	Rear panel <D>
	27122245B	Rear panel <P/PB/PT>
	27122246B	Rear panel <W>
	27122248B	Rear panel <K>
84	838445102	4.5STB+10BQ(BC), Special screw
85	27267948	Guide, power <D/W/PT/K> <B>
	27267942Y	Guide, power <P/PB> <B>
	27267950	Guide, power <G>
86	28325412	Knob, power <P/PB>
91	223021	TBM-51W9043, Isolation sheet
92	223025	AC262, Isolation sheet
95	260208	Wire tie
96	27255004	CS-1U, Clip
D911	22380279	RS804, Rectifier diode
D915	22380274,	RS603M,
	22380038 or	RBV602 or
	22380070	D5SBA60, Rectifier diode
F901	252155	10A-TSC, Fuse <D/W>
F902	252078	5A-SE-EAK, Fuse <P/W/K>
F903	252075	2.5A-SE-EAK, Fuse <P>
F915,F916	252153	6.3A-TSC, Fuse <D>
	25079	6.3A-SE-EAK, Fuse <P/W/K>
JL701	2047402512	NCFC7-402512, Flexible flat cable
P901	253192HIT	AS-UC-6#18, Power supply cord <D>
	253233KAW	AS-CEE-2, Power supply cord <P/W>
	253198HIT	AS-BS, Power supply cord <PB>
P904	253213WSE	KS-AS, Power supply cord <K>
P971	25051266	NSCT-2P1056, AC outlet <K>
Q511,Q611,Q1511	24502282	D09T-24TG10(MA), Fan
Q512,Q612,Q1512	22030000	2SA1930,Transistor
Q513,Q613	2203073 or	2SC5171,Transistor
Q1513	2203072	* 2SA1987-R,Transistor
Q514,Q614	2203083 or	* 2SC5359-O or
Q1514	2203082	* 2SC5359-R,Transistor
Q563,Q663	2203063 or	* 2SC5198-O or
	2203062	* 2SC5198-R,Transistor
Q564,Q664	2203053 or	* 2SA1941-O or
	2203052	* 2SA1941-R,Transistor
T901	2301201	NPT-1272D, Power transformer <D>
	2301202	NPT-1272P, Power transformer <F>
	2301203	NPT-1272DG, Power transformer <W/K>
U11	1A696595-1A	NAAR-5795-1A, Main circuit pc board assembly <D>
	1A696595-1B	NAAR-5795-1B, Main circuit pc board assembly <P/PB>
	1A696595-1C	NAAR-5795-1C, Main circuit pc board assembly <PT>
	1A696595-1D	NAAR-5795-1D, Main circuit pc board assembly <W>
	1A696595-1E	NAAR-5795-1E, Main circuit pc board assembly <K>

REF. NO.	PART NO.	DESCRIPTION	REF. NO.	PART NO.	DESCRIPTION
U12	1A696596-1A	NAAF-5796-1A, Tone control circuit pc board assembly <D>	U53	1A696511-1A	NAETC-5811-1A, Transistor terminal pc board assembly <D>
	1A696596-1B	NAAF-5796-1B, Tone control circuit pc board assembly <P/PB>		1A696511-1B	NAETC-5811-1B, Transistor terminal pc board assembly <P>
	1A696596-1C	NAAF-5796-1C, Tone control circuit pc board assembly <PT>		1A696511-1D	NAETC-5811-1D, Transistor terminal pc board assembly <W>
	1A696596-1D	NAAF-5796-1D, Tone control circuit pc board assembly <W>	U54	1A696511-1E	NAETC-5811-1E, Transistor terminal pc board assembly <K>
U21	1A696596-1A	NAAF-5796-1A, Tone control circuit pc board assembly <W>		1A696512-1A	NAETC-5812-1A, Transistor terminal pc board assembly <D>
	1A696596-1E	NAAF-5796-1E, Tone control circuit pc board assembly <K>		1A696512-1B	NAETC-5812-1B, Transistor terminal pc board assembly <P>
	1A696598-1A	NADIS-5798-1A, Display circuit pc board assembly <D>		1A696512-1D	NAETC-5812-1D, Transistor terminal pc board assembly <W>
	1A696598-1B	NADIS-5798-1B, Display circuit pc board assembly <P/PB>	U55	1A696512-1E	NAETC-5812-1E, Transistor terminal pc board assembly <K>
	1A696598-1C	NADIS-5798-1C, Display circuit pc board assembly <PT/W/K>		1A696513-1A	NAETC-5813-1A, Bias transistor pc board assembly <D>
U22	1A696599-1A	NAAF-5799-1A, Volume circuit pc board assembly <D>		1A696513-1B	NAETC-5813-1B, Bias transistor pc board assembly <P>
	1A696599-1B	NAAF-5799-1B, Volume circuit pc board assembly <P/PB>		1A696513-1D	NAETC-5813-1D, Bias transistor pc board assembly <W>
	1A696599-1C	NAAF-5799-1C, Volume circuit pc board assembly <PT/W/K>	U56	1A696513-1E	NAETC-5813-1E, Bias transistor pc board assembly <K>
U23	1A696500-1A	NAAF-5800-1A, Pre. output pc board assembly <D>		1A696514-1A	NAETC-5814-1A, Bias transistor pc board assembly <W>
	1A696500-1B	NAAF-5800-1B, Pre. output pc board assembly <P/PB>		1A696514-1B	NAETC-5814-1B, Bias transistor pc board assembly <P>
	1A696500-1C	NAAF-5800-1C, Pre. output pc board assembly <PT/W/K>		1A696514-1D	NAETC-5814-1D, Bias transistor pc board assembly <W>
U24	1A696501-1A	NAAF-5801-1A, Headphone terminal pc board assembly <D>		1A696514-1E	NAETC-5814-1E, Bias transistor pc board assembly <K>
	1A696501-1B	NAAF-5801-1B, Headphone terminal pc board assembly <P/PB>	U57	1A696515-1A	NAETC-5815-1A, Bias transistor pc board assembly <D>
	1A696501-1C	NAAF-5801-1C, Headphone terminal pc board assembly <PT/W/K>		1A696515-1B	NAETC-5815-1B, Bias transistor pc board assembly <P>
U31	1A696502-1A	NARF-5802-1A, Tuner circuit pc board assembly <D>		1A696515-1D	NAETC-5815-1D, Bias transistor pc board assembly <W>
	1A696502-1B	NARF-5802-1B, Tuner circuit pc board assembly <P/PB>	U58	1A696515-1E	NAETC-5815-1E, Bias transistor pc board assembly <K>
	1A696502-1C	NARF-5802-1C, Tuner circuit pc board assembly <PT>		1A696516-1A	NAETC-5816-1A, Transistor terminal pc board assembly <D>
	1A696502-1D	NARF-5802-1D, Tuner circuit pc board assembly <W>		1A696516-1B	NAETC-5816-1B, Transistor terminal pc board assembly <P>
U32	1A696503-1A	NAVF-5803-1A, S video circuit pc board assembly <D>		1A696516-1D	NAETC-5816-1D, Transistor terminal pc board assembly <W>
	1A696503-1B	NAVF-5803-1B, S video circuit pc board assembly <P/PB>	U59	1A696516-1E	NAETC-5816-1E, Transistor terminal pc board assembly <K>
	1A696503-1C	NAVF-5803-1C, S video circuit pc board assembly <PT>		1A696517-1A	NAAF-5817-1A, Surround amplifier pc board assembly <D>
	1A696503-1D	NAVF-5803-1D, S video circuit pc board assembly <W>		1A696517-1B	NAAF-5817-1B, Surround amplifier pc board assembly <P>
U33	1A696504-1A	NAVD-5804-1A, On screen circuit pc board assembly <D>		1A696517-1D	NAAF-5817-1D, Surround amplifier pc board assembly <W>
	1A696504-1B	NAVD-5804-1B, On screen circuit pc board assembly <P/PB>	U60	1A696517-1E	NAAF-5817-1E, Surround amplifier pc board assembly <K>
	1A696504-1C	NAVD-5804-1C, On screen circuit pc board assembly <PT>		1A696518-1A	NAETC-5818-1A, Transistor terminal pc board assembly <D>
	1A696504-1D	NAVD-5804-1D, On screen circuit pc board assembly <W>		1A696518-1B	NAETC-5818-1B, Transistor terminal pc board assembly <P>
U34	1A696505-1A	NADG-5805-1A, MR/RI terminal pc board assembly <D>	U61	1A696518-1E	NAETC-5818-1E, Transistor terminal pc board assembly <K>
	1A696505-1B	NADG-5805-1B, MR/RI terminal pc board assembly <P/PB>		1A696519-1A	NAETC-5819-1A, AC outlet terminal pc board assembly <D>
	1A696505-1C	NADG-5805-1C, MR/RI terminal pc board assembly <PT>		1A696519-1B	NAETC-5819-1B, AC outlet terminal pc board assembly <P>
	1A696505-1D	NADG-5805-1D, MR/RI terminal pc board assembly <W>	U62	1A696522-1E	NAETC-5822-1E, AC outlet terminal pc board assembly <K>
U35	1A696506-1A	NADG-5806-1A, AC-3 terminal pc board assembly <D>		1A696522-1A	NAETC-5822-1A, Transistor terminal pc board assembly <D>
	1A696506-1B	NADG-5806-1B, AC-3 terminal pc board assembly <P/PB>		1A696520-1B	NAETC-5820-1B, Transistor terminal pc board assembly <P>
	1A696506-1C	NADG-5806-1C, AC-3 terminal pc board assembly <PT>	U63	1A696520-1E	NAETC-5820-1E, Transistor terminal pc board assembly <K>
	1A696506-1E	NADG-5806-1E, AC-3 terminal pc board assembly <K>		1A696520-1D	NAETC-5820-1D, Transistor terminal pc board assembly <W>
U36	1A696507-1A	NAETC-5807-1A, Video 4 terminal pc board assembly <D>		1A696521-1A	NAPS-5821-1A, Power supply circuit pc board assembly <D>
	1A696507-1B	NAETC-5807-1B, Video 4 terminal pc board assembly <P/PB>		1A696521-1B	NAPS-5821-1B, Power supply circuit pc board assembly <P>
	1A696507-1C	NAETC-5807-1C, Video 4 terminal pc board assembly <PT>	U64	1A696521-1E	NAPS-5821-1E, Power supply circuit pc board assembly <K>
	1A696507-1D	NAETC-5807-1D, Video 4 terminal pc board assembly <W>		1A696523-1B	NAPS-5823-1B, Primary circuit pc board assembly <P>
	1A696507-1E	NAETC-5807-1E, Video 4 terminal pc board assembly <K>		1A696523-1D	NAPS-5823-1D, Primary circuit pc board assembly <W>
U41	1A696508-1	NADG-5808-1, DSP circuit pc board assembly	U65	1A696523-1A	NAPS-5823-1A, Primary circuit pc board assembly <K>
U51	1A696509-1A	NAAF-5809-1A, Front and center main amp. pc board assembly <D>		1A696523-1B	NAPS-5823-1B, Primary circuit pc board assembly <P>
	1A696509-1B	NAAF-5809-1B, Front and center main amp. pc board assembly <P>		1A696524-1A	NAPS-5824-1A, Secondary circuit pc board assembly <D>
	1A696509-1D	NAAF-5809-1D, Front and center main amp. pc board assembly <W>		1A696524-1B	NAPS-5824-1B, Secondary circuit pc board assembly <P>
	1A696509-1E	NAAF-5809-1E, Front and center main amp. pc board assembly <K>	U66	1A696524-1D	NAPS-5824-1D, Secondary circuit pc board assembly <W>
	1A696510-1A	NAETC-5810-1A, Transistor terminal pc board assembly <D>		1A696525-1A	NAETC-5825-1A, Speaker terminal pc board assembly <D>
	1A696510-1B	NAETC-5810-1B, Transistor terminal pc board assembly <P>		1A696525-1B	NAETC-5825-1B, Speaker terminal pc board assembly <P>
	1A696510-1D	NAETC-5810-1D, Transistor terminal pc board assembly <W>	U67	1A696525-1D	NAETC-5825-1D, Speaker terminal pc board assembly <W>
	1A696510-1E	NAETC-5810-1E, Transistor terminal pc board assembly <K>		1A696526-1A	NAETC-5826-1A, Speaker terminal pc board assembly <D>
				1A696526-1B	NAETC-5826-1B, Speaker terminal pc board assembly <P>
				1A696526-1E	NAETC-5826-1E, Speaker terminal pc board assembly <W>

## PRINTED CIRCUIT BOARD-PARTS LIST

TUNER CIRCUIT PC BOARD (NARF-5802-1A/1B/1C/1D/1E)			CIRCUIT NO.	PART NO.	DESCRIPTION
CIRCUIT NO.	PART NO.	DESCRIPTION		Capacitors	
TU101	Front end 240088 240089	FE337-A07 <D> FE415-G11 <P/PT/PB/W/K>	C1151,C1152 C1154 C1155,C1156	354780109 354741009 374721034 374724324 374724724	1 $\mu$ F,50V, Elect. 10 $\mu$ F,16V, Elect. 0.01 $\mu$ F $\pm$ 5%, 50V, Plastic <D> 4300pF $\pm$ 5%, 50V, Plastic <P/PB> 4700pF $\pm$ 5%, 50V, Plastic <PT/W/K>
Q1121	22240090	LM7001		354780229	2.2 $\mu$ F,50V, Elect.
Q1141	22240983	LA1851N-F	C1159,C1177	354784799	0.47 $\mu$ F,50V, Elect.
Q1176	22240293 or 22240247	NJM4558L-D or BA15218N	C1160 C1162,C1166	353741009	10 $\mu$ F,16V, Elect.
Q1181	22240679	MPC1346CS <P/PB>	C1168	374724734	0.047 $\mu$ F $\pm$ 5%, 50V, Plastic
	<b>Transistors</b>			354741009	10 $\mu$ F,16V, Elect.
Q1101,Q1102	2215063	2SC2669-O	C1171,C1172	374722724	2700pF $\pm$ 5%, 50V, Plastic
Q1103,Q1104	2215063	2SC2669-O <P/PB/PT/W/K>	C1173,C1174	354741009	10 $\mu$ F,16V, Elect.
Q1122,Q1142	2213510 or	DTA114ES or	C1175,C1176	354741009	10 $\mu$ F,16V, Elect.
Q1175	2214350	RN2202	C1178,C1179	374724724	4700pF $\pm$ 5%, 50V, Plastic <P/PB>
Q1123	2212445	2SK365-GR	C1183	374722234	0.022 $\mu$ F $\pm$ 5%, 50V, Plastic <P/PB>
Q1124	2213284 or 2212115	2SC1740S-R or 2SC2458-GR	C1184 C1185	374724734	0.047 $\mu$ F $\pm$ 5%, 50V, Plastic <P/PB>
Q1143	221282 or 2213560	DTC144ES or RN1204	C1186	354780229	2.2 $\mu$ F,50V, Elect. <P/PB>
Q1144	2213640 or 2214660	DTC123JS or RN1205	C1187,C1188	374723324	3300pF $\pm$ 5%, 50V, Plastic <P/PB>
Q1171,Q1172	2213284 or 2212115	2SC1740S-R or 2SC2458-GR	C1189	374724724	4700pF $\pm$ 5%, 50V, Plastic <P/PB>
Q1173,Q1174	2215024	2SD1468S-R	C1190	354721019	100 $\mu$ F,6.3V, Elect. <P/PB>
Q1182	2213284 or 2212115	2SC1740S-R or 2SC2458-GR <P/PB>			
	<b>Diode</b>				
D1165	224450512	MTZ5.1B, Zener	R1114	442524794	0.47 $\Omega$ $\pm$ 5%,1/2W, Metal oxide
	<b>Transformers</b>		R1150	5210261	N06HR5KBC, Trimming
L1101	233457	NFIF-4081, IF	R1158	5210263	N06HR20KBC, Trimming
L1102	233458	NFIF-4082, IF	R1191	5210265	N06HR50KBC, Trimming <P/PB>
L1105	232174	NMRF-5077, RF Block			
L1106	232139	NMF-4062, IF			
	<b>Coils</b>				
L1103	233471	NMC-6084, MPX <P/PT/PB/W/K>	P1101	25060195	NTM-4PDM117, Antenna <D>
L1104	233454M022	NCH-1452-022M, Choke		25060117	NTM-2PDMN051, Antenna <P/PB/PT/W/K>
L1107,L1108	233484	NMC-4085, MPX			
	<b>Ceramic filters</b>				
X1101,X1102	3010071	SFE10.7MA5 (RED)			
X1102	3010071	SFE10.7MA5 (RED) <P/PB/PT/W/K>	P1102	25050985	NSCT-12P772 <D/PT/K>
X1103	3010071	SFE10.7MA5 (RED) <D>		25050987	NSCT-16P774 <P/PB>
	3010130	SFE10.7MZ2A <P/PB/PT/W/K>		25050986	NSCT-14P773 <W>
X1104	3010268	CSB456F23			
X1105	3010123	SFZ-450JL			
	<b>Resonators</b>				
X1121	3010141	XTL-7.2M, Crystal	TP1101	25055038	NPLG-2P29
X1181	3010203	AF6146CG, Crystal <P/PB>	TP102	25055038	NPLG-2P29 <P/PB>
	<b>Capacitors</b>				
C1101	354741019	100 $\mu$ F,16V, Elect.			
C1127	354721019	100 $\mu$ F,6.3V, Elect.			
C1130	354780229	2.2 $\mu$ F,50V, Elect.			
C1131	374722234	0.022 $\mu$ F $\pm$ 5%, 50V, Plastic			
C1132,C1153	354783399	0.33 $\mu$ F,50V, Elect.			
C1133,C1142	354741019	100 $\mu$ F,16V, Elect.			
C1145,C1149	354780479	4.7 $\mu$ F,50V, Elect.			
C1146	374723324	3300pF $\pm$ 5%, 50V, Plastic			
C1147	374721034	0.01 $\mu$ F $\pm$ 5%, 50V, Plastic <P/PB/PT/W/K>			
	374721534	0.015 $\mu$ F $\pm$ 5%, 50V, Plastic <D>			

NOTE: <D>:120V model only <PT>:Asian model only  
 <P>:230V model only <PB>: U.K. model only  
 <W>:Worldwide model only  
 <K>: Korean model only

## PACKING VIEW

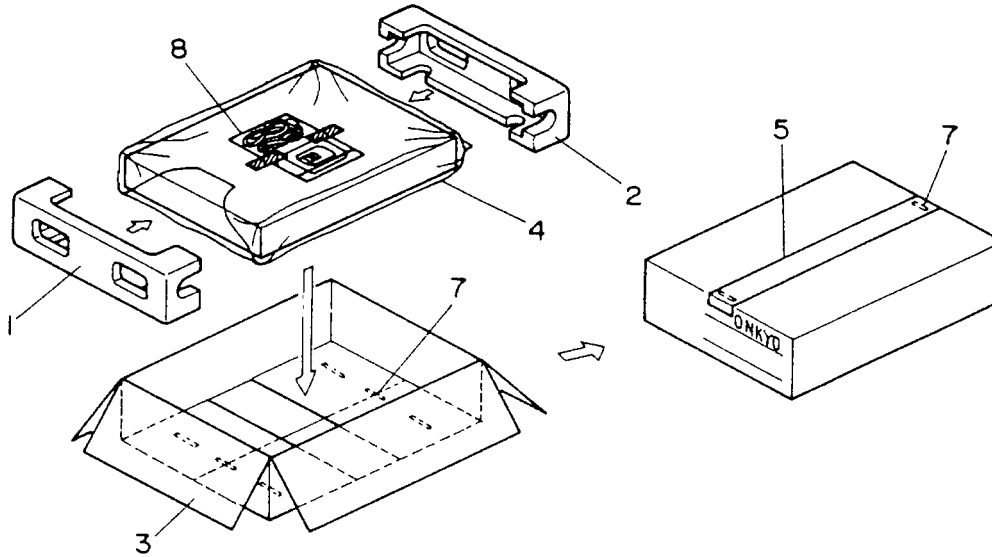

REF.NO.	PART NO.	DESCRIPTION
1	29100034A	Styren bag
2	29053040	Carton box <D/W/PT/K>
2	29053041	Carton box <P/PB>
2	29053051	Carton box <G>
3	282321	Staple
4	29091743A	Pad
6	261504	Paper tape
7	29110071	PP tape
8	<b>Accessory bag assembly</b>	
	232140	NMA-3057, AM loop antenna
	24140036	RC-P101S, Remote control <D>
	24140037	RC-P201S, Remote control <P/W/K>
	25055018	CV-K-1, Conversion plug
	25065462	YAE21-0237, FM antenna adapter <W>
	29100097-1Y	350*250, Styren bag
	292111Y	FM antenna <D>
	292112Y	FM antenna <P/W/K>
	29342335	Instruction manual E
	29342336	Instruction manual U3 (IDSW) <P>
	29342337	Instruction manual U3 (GFS) <P>
	29342338	Instruction manual T <PT/W>
	29342353Y	Instruction manual, remote control
	29355133A	Instruction sheet <P>
	29355261	Instruction sheet <D>
	29358002K	Service station list <D>
	29361759Y	Label UL/CUL <D>
	29361980	Label UPC <D>
	29365019B	Warranty card <D>
	3010054	UM-3, Battery
	880009	NRP-345, Plastic rivet <P>

NOTE: <B>: Black model only  
 <G>: Golden model only  
 <D>: 120V model only  
 <P>: 230V model only  
 <PB>: U.K model only  
 <PT>: Asian model only  
 <W>: Worldwide model only  
 <K>: Korean model only

## TABLE OF CONTENTS

Specifications.....	2
Service guide.....	3
Block diagram.....	4
Tuner section.....	4
Video section.....	5
Power supply section.....	6
Microprocessor connection diagram.....	7
Microprocessor terminal description.....	8
Sub-microprocessor connection diagram.....	10
Sub-microprocessor terminal description.....	11
IC block diagrams and descriptions.....	See parts under Components
Adjustment procedures.....	28
Wiring diagram.....	31
Schematic diagram.....	33
Block diagram.....	33
Input/output and microprocessor section.....	35
Volume and selector section.....	45
AC-3 and DSP section.....	47
Front/center amp. section.....	53
Tone and RI section.....	55
Surround amp. section.....	61
Video section.....	63
Tuner and display section.....	69
PC board-parts list.....	39
Volume and selector section.....	43
Tone and RI section.....	58
Surround amp. section.....	59
Video section.....	65
Display section.....	67
Tuner and display section.....	79
Exploded view .....	71
Parts list.....	73
Block diagram-Amplifier section.....	75
Packing view.....	81

---

## ONKYO CORPORATION

International Sales Div.: 31 Sankyo-bld. 3-8-5, Asakusabashi, Taito-ku, TOKYO 111, JAPAN  
 TEL : 03-5820-5865    FAX : 03-5820-5869

ONKYO U.S.A. CORPORATION  
 200 Williams Drive, Ramsey, N.J. 07446, U.S.A.  
 TEL : 201-825-7950    FAX : 201-825-8150

ONKYO EUROPE ELECTRONICS GmbH  
 Industriestrasse 18-20, 82110 Germering, GERMANY  
 TEL : 089 84 93 20    FAX : 089 84 93 226

ONKYO FRANCE  
 Immeuble Le Diamant, Domaine Technologique de Saclay, 4 Rue Rene Razel, 91892 SACLAY, FRANCE  
 TEL : (1) 69 33 1400    FAX : (1) 69 41 35 84