

ONKYO SERVICE MANUAL

AV Receiver

MODEL TX-L55



MODEL TX-LR552

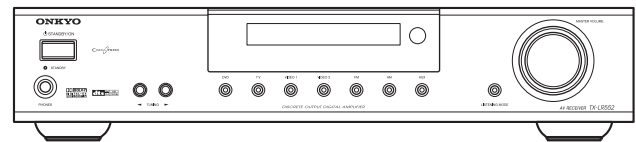

Silver models

SMPP, SMPA	230-240V AC, 50Hz
SMGQ, SMGR, SMGT	220-230V AC, 50Hz

Titanium and Silver models

TMDD	120V AC, 60Hz
SMDD	120V AC, 60Hz

SAFETY-RELATED COMPONENT WARNING!!

COMPONENTS IDENTIFIED BY MARK  ON THE SCHEMATIC DIAGRAM AND IN THE PARTS LIST ARE CRITICAL FOR RISK OF FIRE AND ELECTRIC SHOCK. REPLACE THESE COMPONENTS WITH ONKYO PARTS WHOSE PART NUMBERS APPEAR AS SHOWN IN THIS MANUAL.

MAKE LEAKAGE-CURRENT OR RESISTANCE MEASUREMENTS TO DETERMINE THAT EXPOSED PARTS ARE ACCEPTABLY INSULATED FROM THE SUPPLY CIRCUIT BEFORE RETURNING THE APPLIANCE TO THE CUSTOMER.

SPECIFICATIONS

Amplifier Section

Power output:	Front L/R 65 W + 65 W Center 65 W Surround L/R 65 W + 65 W Surround back L/R 65 W (6 Ω , 1 kHz, FTC)
Dynamic power:	40 W + 40 W (8 Ω , front)
THD (total harmonic distortion):	FTC 5.0% (rated power)
Damping factor:	75 (front, 1 kHz, 8 Ω)
Input sensitivity and impedance:	200 mV/47 k Ω (AUX)
Output level and impedance:	200 mV/470 Ω (REC OUT)
Frequency response:	10 Hz~60 kHz/+1.5 dB, +/-3 dB (AUX)
Tone control:	\pm 12 dB, 100 Hz (BASS) \pm 12 dB, 20,000 Hz (TREBLE)
S/N ratio (Direct mode):	100 dB (AUX, IHF-A)
Speaker impedance:	6 Ω ~ 16 Ω

Video Section

Input sensitivity, output level and impedance:	1.0 Vp-p/75 Ω (component and S-Video Y) 0.7 Vp-p/75 Ω (component Pb/Cb, Pr/Cr) 0.28 Vp-p/75 Ω (S-Video C) 1.0 Vp-p/75 Ω (composite)
Component video frequency response:	5 Hz~50 MHz

Tuner Section

FM

Tuning frequency range:	87.5~107.9 MHz
Usable sensitivity:	Stereo 17.2 dBf, 2.0 μ V (75 Ω IHF) Mono 11.2 dBf, 1.0 μ V (75 Ω IHF)
S/N ratio:	Stereo 67 dB (IHF-A) Mono 70 dB (IHF-A)
Frequency response:	30 Hz~15 kHz/+1 dB, Δ 1 dB
Stereo separation:	45 dB at 1 kHz

AM

Tuning frequency range:	530~1710 kHz
Usable sensitivity:	30 μ V
S/N ratio:	40 dB

General

Power supply:	AC 120 V, 60 Hz
Power consumption:	110 W
Standby power consumption:	1.70 W
Dimensions (W x H x D):	17-1/8" x 3-9/16" x 14-7/16" (435 x 91 x 367 mm)
Weight:	14.3 lbs. (6.5 kg)

Video Inputs

Component video inputs:	2 (COMPONENT VIDEO 1, 2)
S-Video inputs:	3 (DVD, VIDEO 1, VIDEO 2)
Video inputs:	3 (DVD, VIDEO 1, VIDEO 2)

Video Outputs

Component video outputs:	1 (MONITOR)
S-Video outputs:	2 (MONITOR, VIDEO 1)
Video outputs:	2 (MONITOR, VIDEO 1)

Audio Inputs

Digital inputs:	3 (Optical 1, 2, Coaxial)
Analog inputs:	5 (AUX, VIDEO 1, VIDEO 2, TV, DVD)
Multichannel analog inputs:	1

Audio Outputs

Analog outputs:	1 (VIDEO 1)
Subwoofer pre out:	1
Speaker outputs:	6
Phones:	1

Specifications and features are subject to change without notice.

SERVICE PROCEDURES

1. Replacing the fuses



This symbol located near the fuses indicates that the fuse used is fast operating type. For continued protection against fire hazard, replace with same type fuse. For fuse rating refer to the marking adjacent to the symbol.



Ce symbole indique que le fusible utilise est a rapide. Pour une protection permanente, n'utiliser que fusibles de meme type. Ce dernier est la qu le present symbol est appse.

CIRCUIT NO.	PART NO.	DESCRIPTION
F9001	252254 or 252160	2.5A-T/UL-ST2 or 2.5A-UL/T-237 <D>
F9001	252273 or 252073	1.6A-SE-TL250V or 1.6A-SE-EAK <P/G>

Note: <D>: 120V model only
<P>: 230V model only
<G>: 220V model only

2. To initialize the unit

The TX-L55/LR552 contain a micro processor for signal processing and control functions. In very rare situations, severe interference, noise from an external source, or static electricity may cause it to lockup. In the unlikely event that this happens, unplug the power cord from the wall outlet, wait at least five seconds, and then plug it back in again. To reset the TX-L55/LR552 to its factory defaults, turn it on and, while holding down the [◀] TUNING button, press the [STANDBY/ON] button. When the reset is complete, "Clear" appears on the display and the TX-L55/LR552 enter Standby mode.

3. Safety-check out

(U.S.A. model only)

After correcting the original service problem, perform the following safety check before releasing the set to the customer.

Leakage Current Check

Measure leakage current to a known earth ground (water pipe, conduit, etc.) by connecting a leakage current tester between the earth ground and exposed metal parts of the appliance (input/output terminals, screwheads, metal overlays, etc.). Plug the power supply cord directly into a 120V AC 60 Hz outlet and turn Standby switch on. Any current measured must not exceed 0.5mA.

4. Memory backup

The TX-L55/LR552 use a battery-less memory backup system (C7001) in order to retain radio presets and other settings when it's unplugged or in the case of a power failure. Although no batteries are required, it must be plugged into an AC outlet in order to charge the backup system. Once it has been charged, the TX-L55/LR552 will retain the settings for several weeks, although this depends on the environment and will be shorter in humid climates.

5. Setting the AM tuning step frequency

(Asian models only)

If you are using the Asian model, you need to set the AM tuning interval for compatibility with AM broadcasts in your particular country. The initial setting is 9 kHz.

1 	Use the INPUT SELECTOR [TUN] button to select AM.
2 	Press the REMOTE MODE [AMP] button followed by the [SETUP] button.
3 	Use the Up and Down [▲]/[▼] buttons to select 06.Hardware, 0 and then press [ENTER]. <div style="border: 1px solid black; padding: 5px; text-align: center; font-family: monospace;"> AM Freq: 9K </div>
4	Use the Left and Right [◀]/[▶] buttons to select: 9K: North America 10K: Other countries
5 	Press the [SETUP] button. The setup menu closes.

Note:

All presets will be deleted when you change the AM

EXPLODED VIEW

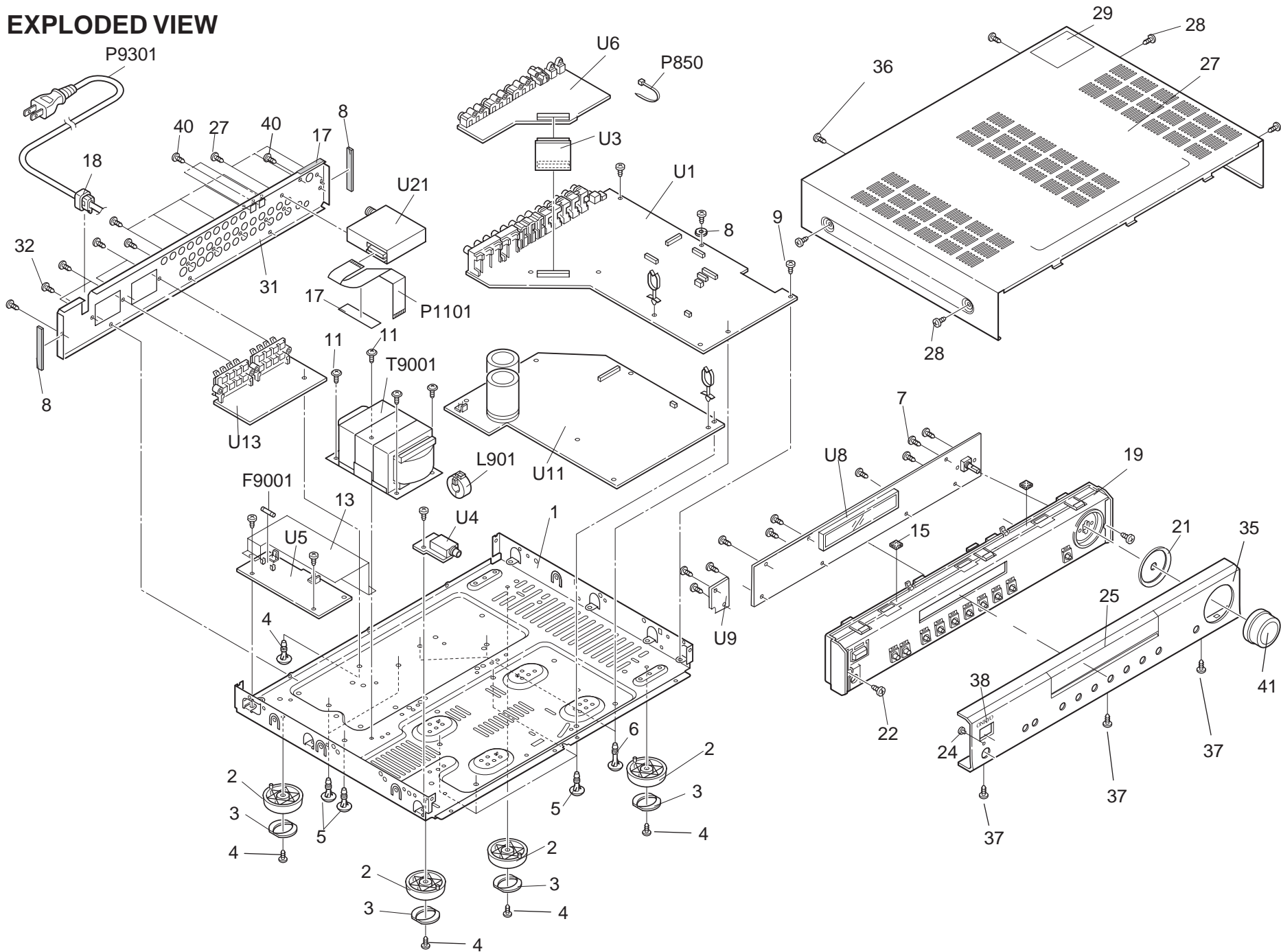

A B C D

BLOCK DIAGRAM

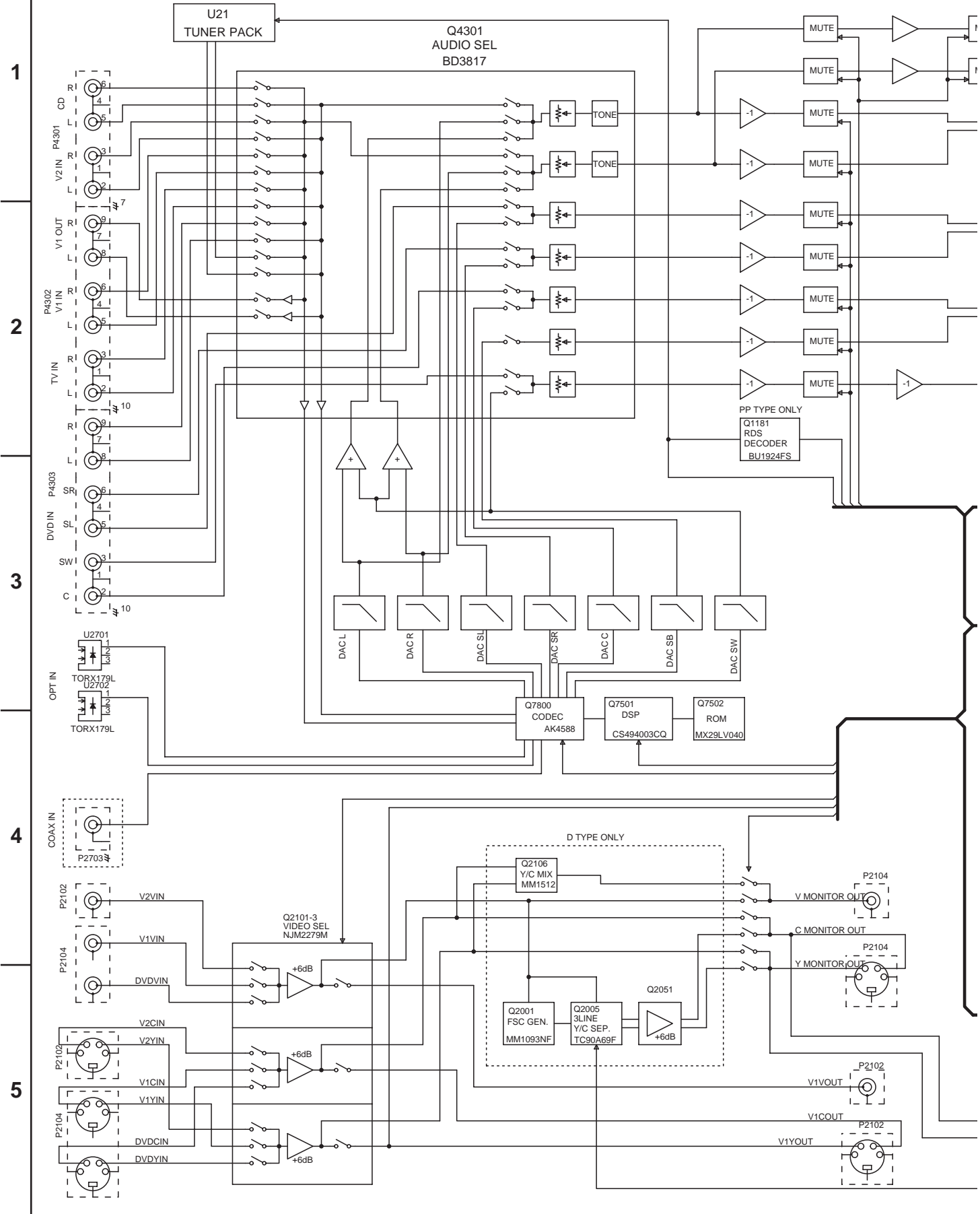

A **B** **C** **D**

BLOCK DIAGRAM

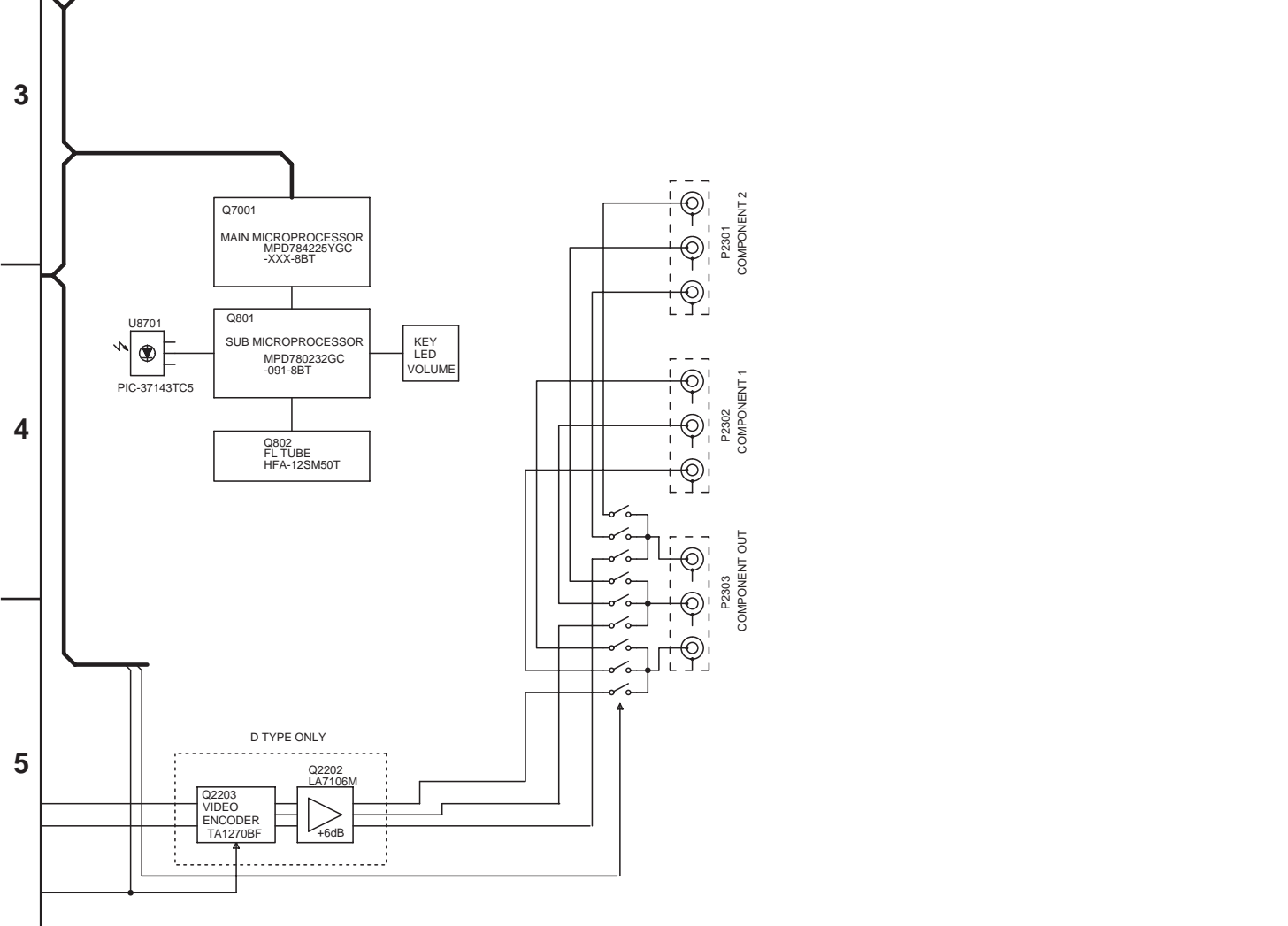
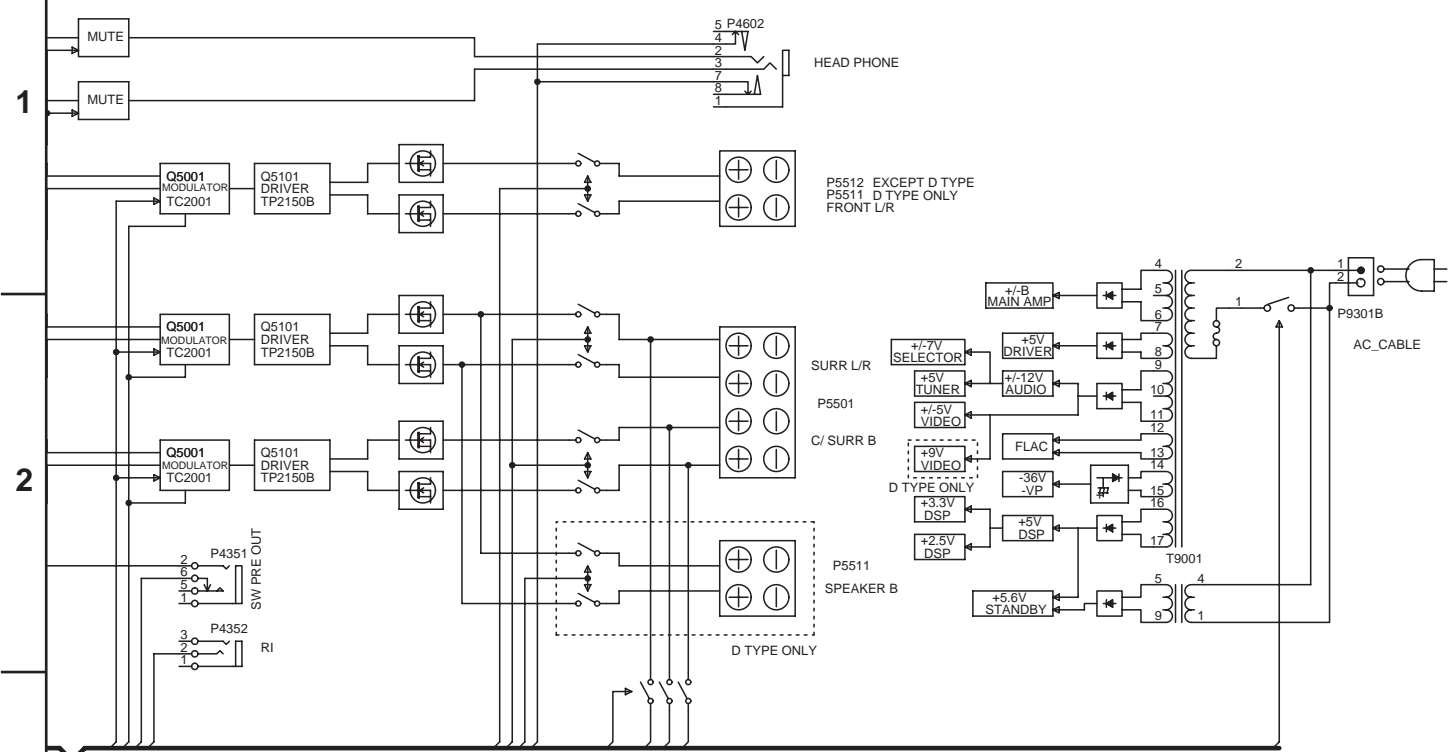

A B C D

SCHEMATIC DIAGRAM 3 DSP section 2

1

2

3

4

5

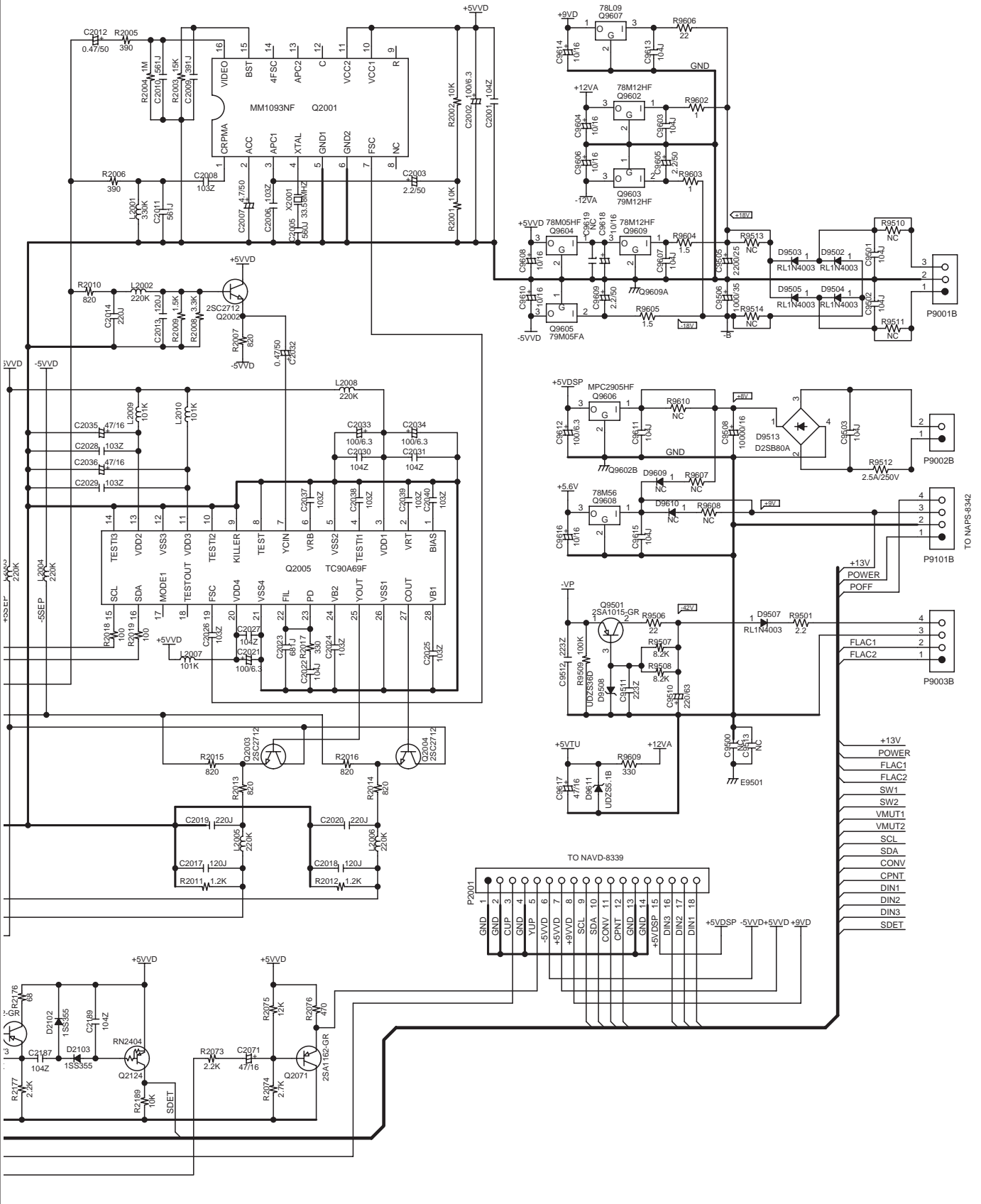

A

B

C

D

E

SCHEMATIC DIAGRAM 6 SPEAKER TERMINAL SECTION

1

2

3

4

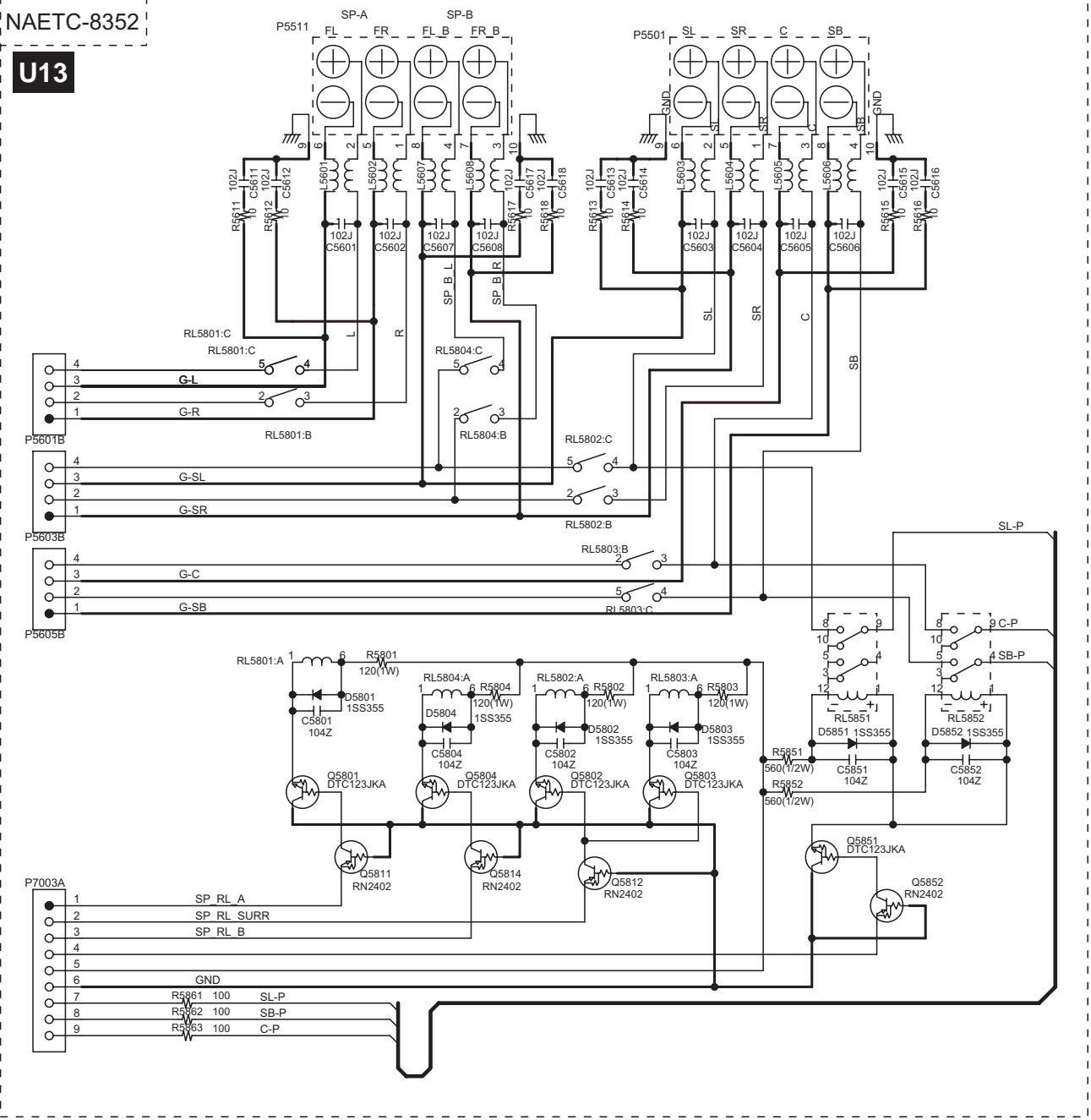

SCHEMATIC DIAGRAM 7 VIDEO SECTION

1
2
3
4

A B C D E

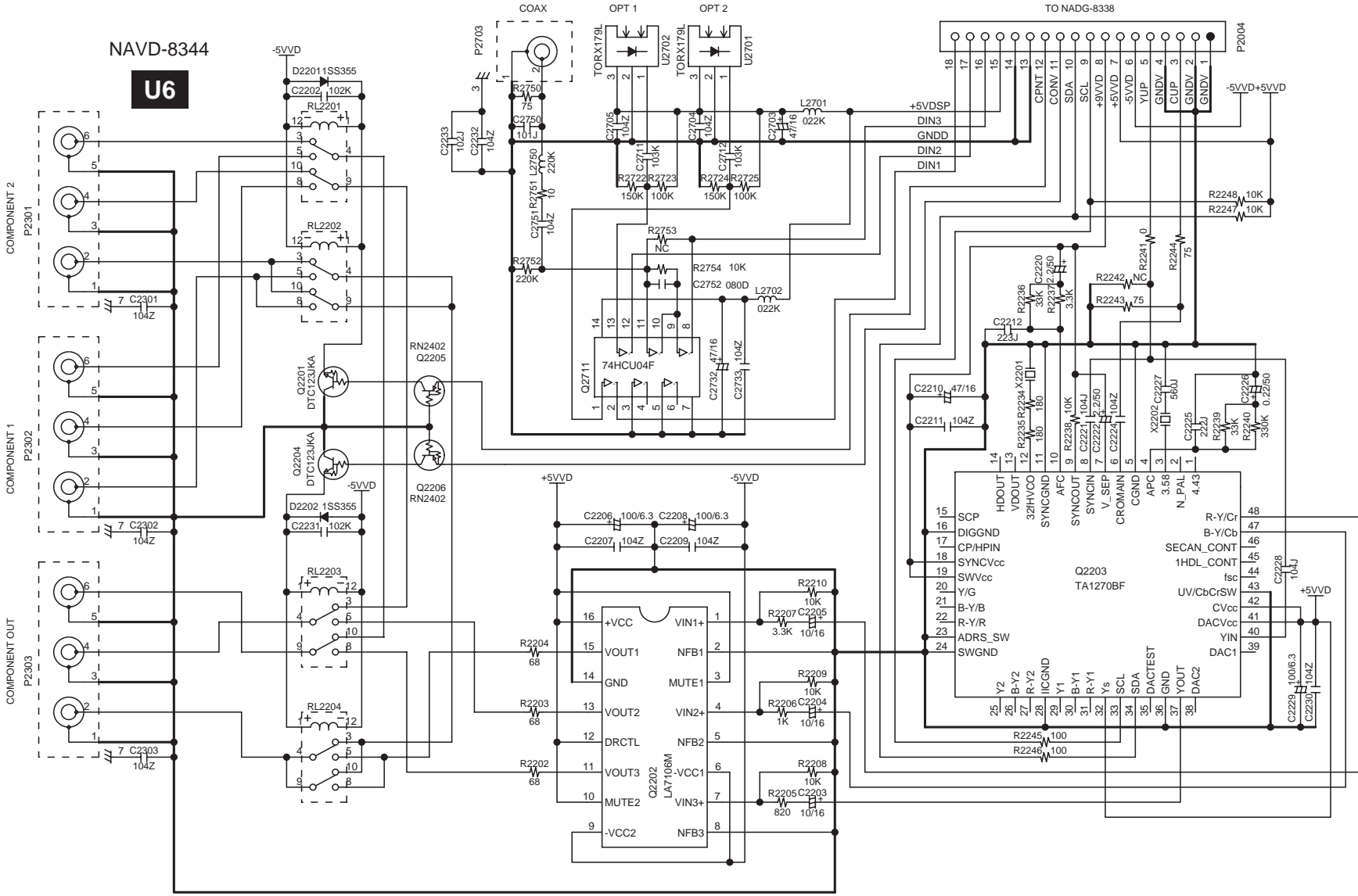

A

B

C

D

SCHEMATIC DIAGRAM 8

1

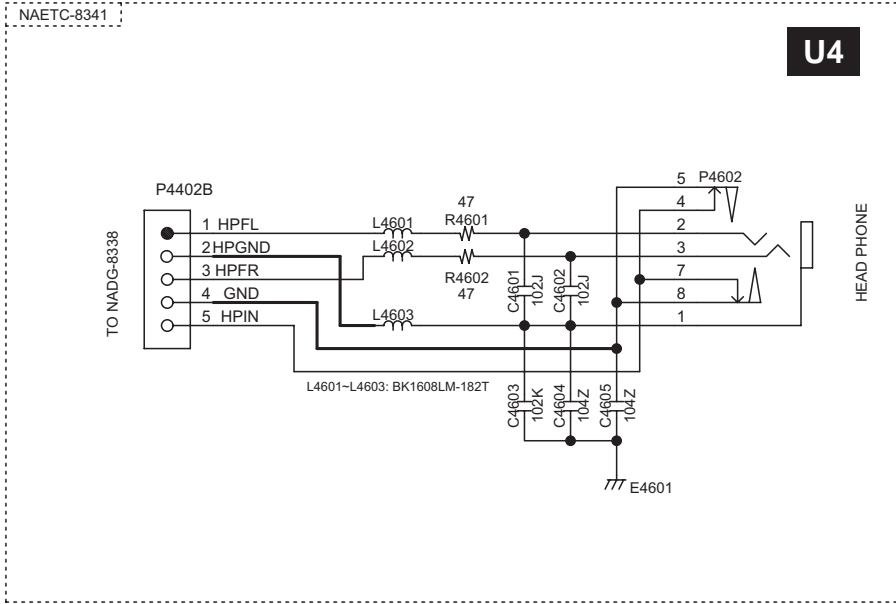

2

3

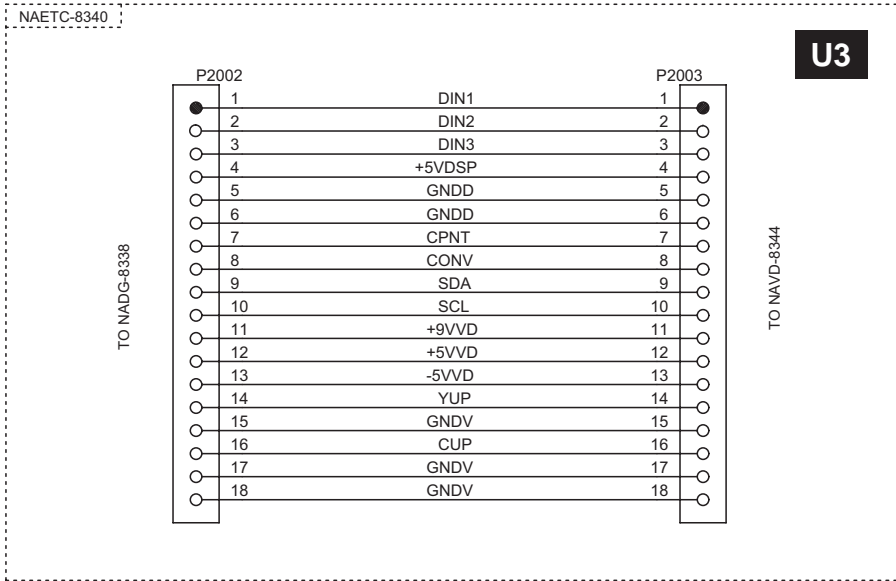

4

5

SCHEMATIC DIAGRAM 1 DISPLAY SECTION

1
2
3
4
5

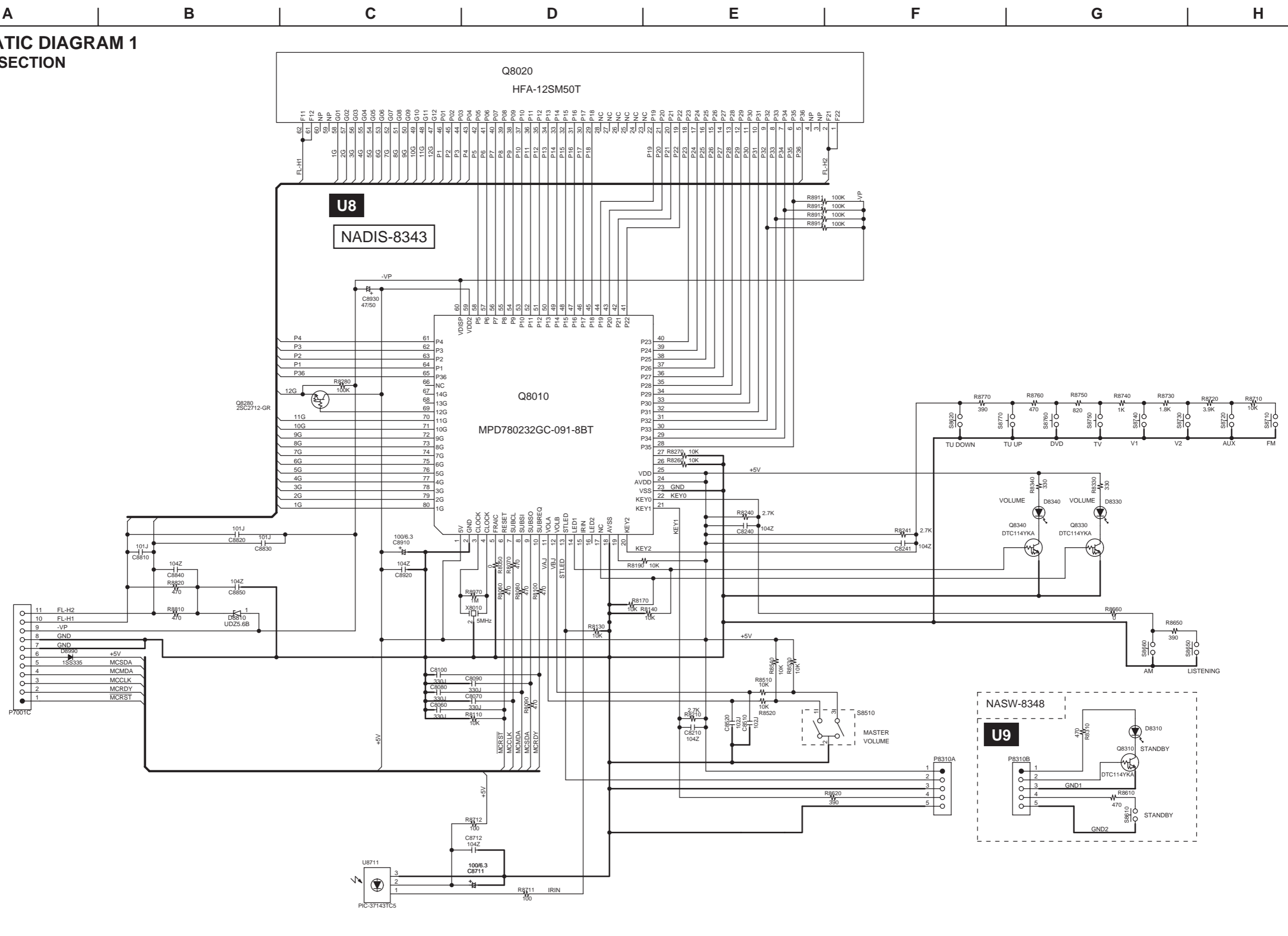

A B C D E F G H
SCHEMATIC DIAGRAM 2 DSP section 1

1

2

3

4

5

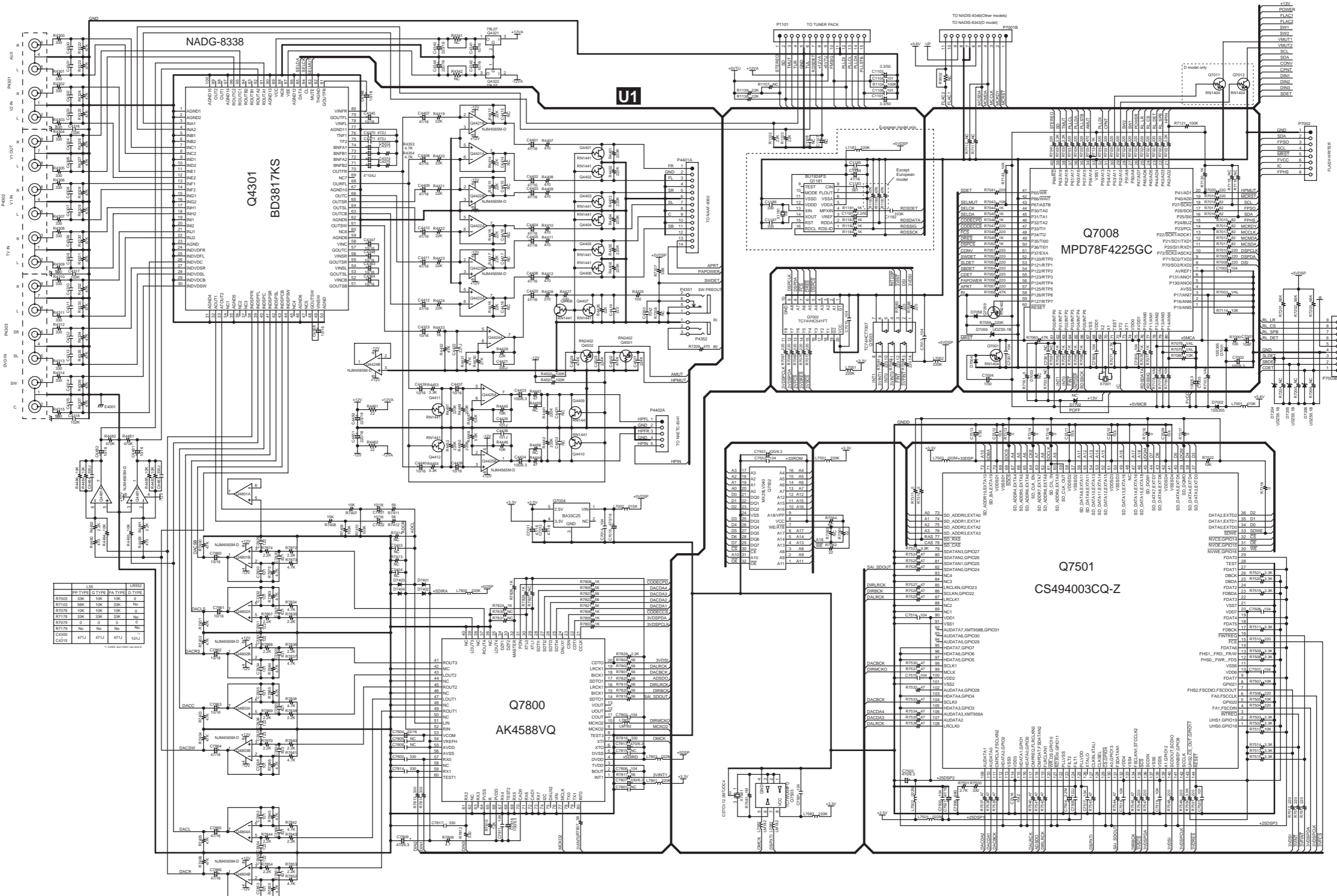

	L55	LR552		
PP TYPE	G TYPE	PA TYPE		
R7053	33K	10K	10K	0
R7103	50K	10K	33K	No
R7078	10K	10K	10K	0
R7178	33K	33K	33K	No
R7079	0	0	No	No
R7179	No	No	No	No
C4300	471J	471J	471J	101J
C4315				

SCHEMATIC DIAGRAM 3 DSP section 2

1

2

3

4

5

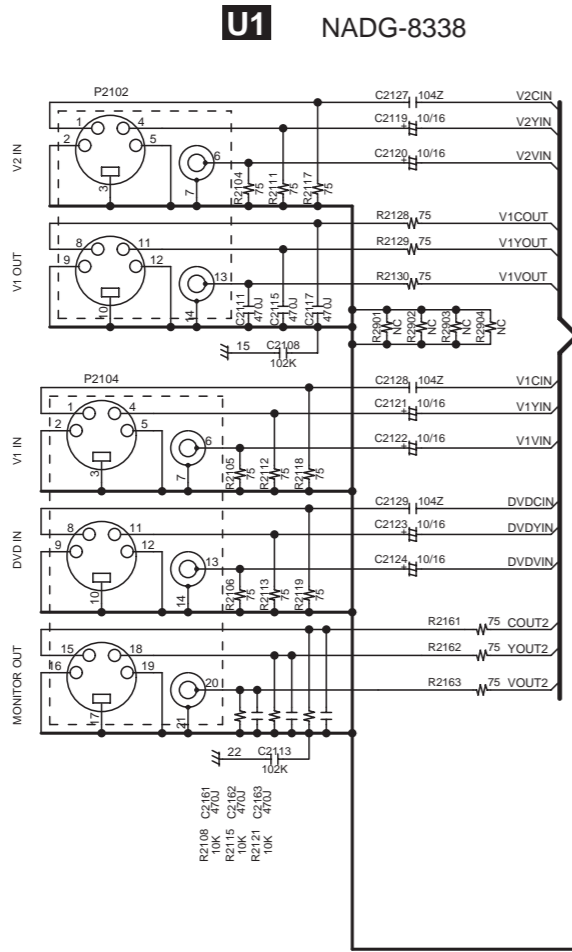

U1 NADG-8338

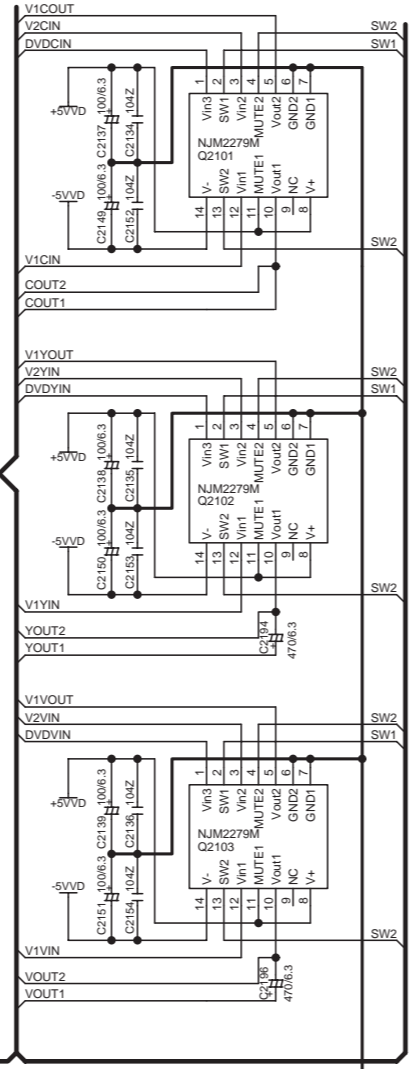

R2168
10K
SDET

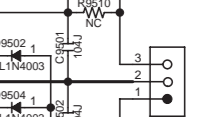
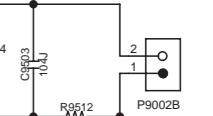
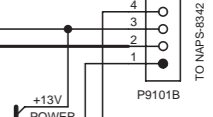
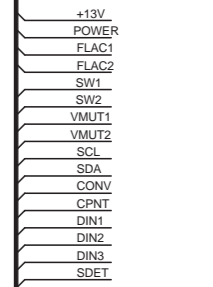
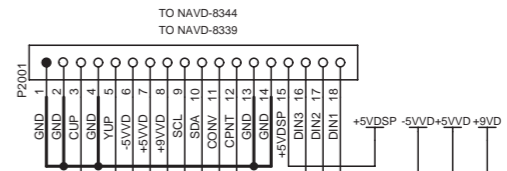
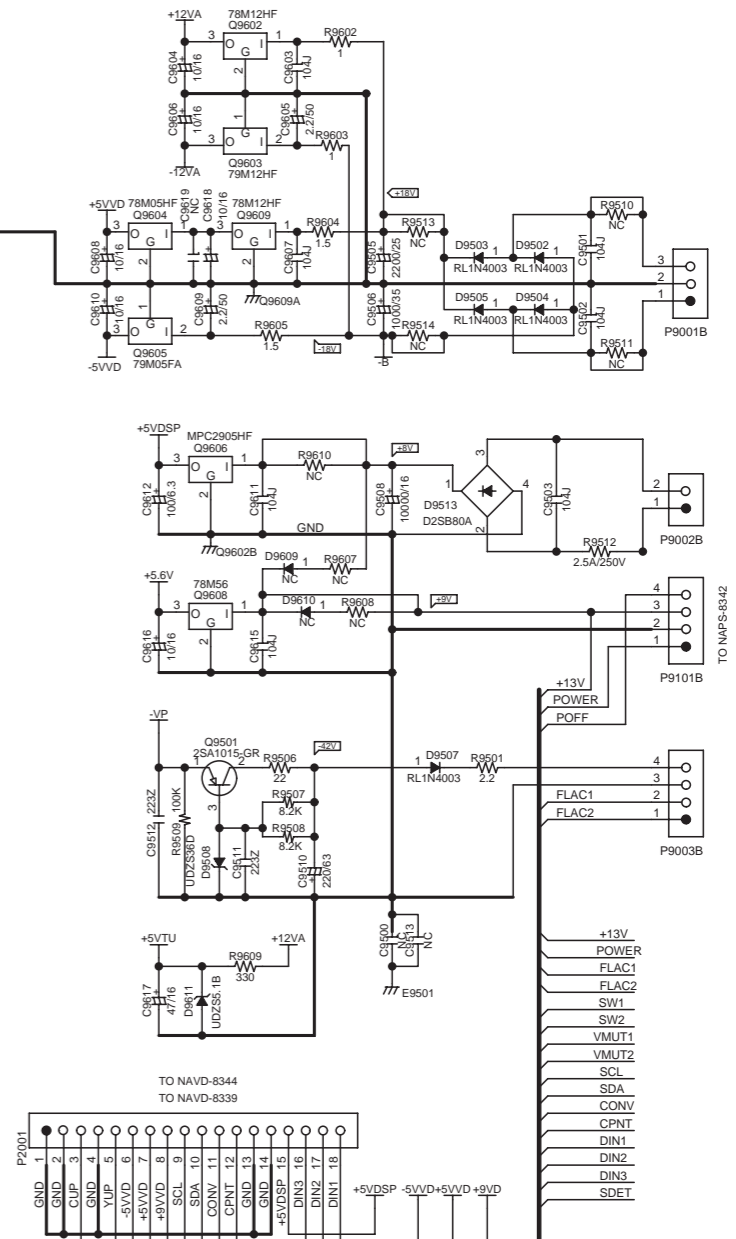

TO NAPS-8342

TO NAVD-8344
TO NAVD-8339

SCHEMATIC DIAGRAM 4 Amplifier section 1

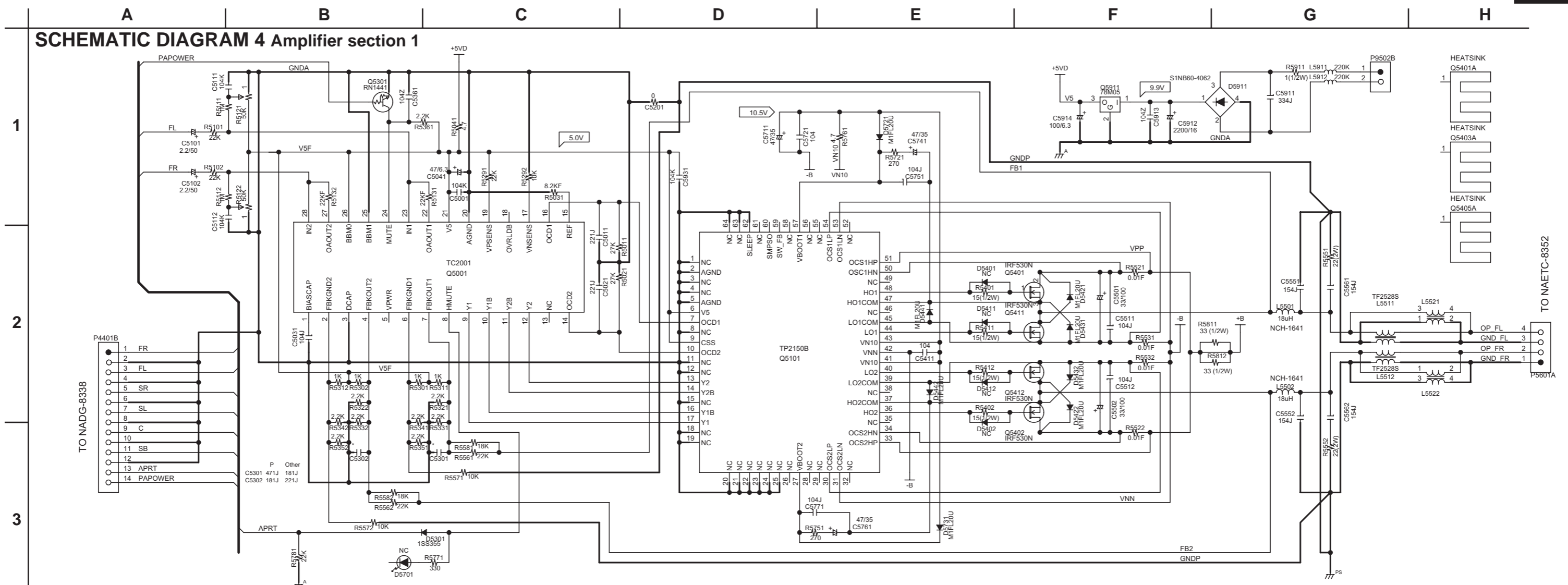

CAUTION
FOR CONTINUED PROTECTION AGAINST FIRE HAZARD, REPLACE ONLY WITH FUSE OF SAME TYPE AND RATING INDICATED.

ATTENTION
AFIN D'ASSURER UNE PROTECTION PERMANENTE CONTRE LES RISQUES D'INCENDIE, REMPLACER UNIQUEMENT PAR UN FUSIBLE DE MEME TYPE ET CALIBRATION COMME INDIQUE.

THIS SYMBOL LOCATED NEAR THE FUSE INDICATES THAT THE FUSE USED IS SLOW OPERATING TYPE FOR CONTINUED PROTECTION AGAINST FIRE HAZARD. REPLACE WITH SAME TYPE FUSE. FOR FUSE RATING REFER TO THE MAKING ADJACENT TO THE SYMBOL.

CE SYMBOLE INDIQUE QUE LE FUSIBLE UTILISE EST A LENT. E POUR UNE PROTECTION PERMANENTE UTILISER QUE DES FUSIBLES DE MEME TYPE. CE DERNIER EST INDIQUE LA QU LE PRESENT SYMBOLE EST APPOSE.

NOTE
THE COMPONENTS IDENTIFIED BY MARK ARE CRITICAL FOR SAFETY. REPLACE ONLY WITH PART NUMBER SPECIFIED.

VOLTAGE (MEASURED WITH VOLTMETER) IS DC VOLTAGE (NO INPUT SIGNAL).

ALL PNP TRANSISTORS ARE EQUIVALENT TO 2SA1015-GR UNLESS OTHERWISE NOTED.
ALL NPN TRANSISTORS ARE EQUIVALENT TO 2SC1815-GR UNLESS OTHERWISE NOTED.
ALL DIODES ARE EQUIVALENT TO 1SS133 UNLESS OTHERWISE NOTED.

ELECTROLYTIC CAPACITORS ARE IN uF/WV.

ALL CAPACITORS ARE IN pF/50V UNLESS OTHERWISE NOTED.
EX) 030-30F 330-330F 331-330F 333-0.033uF

ALL RESISTORS ARE IN OHMS 1/4WATT UNLESS OTHERWISE NOTED.
THE THICK LINES ON PC BOARD ARE THE PRINTING SIDE OF THE PARTS

EX) PRINTING SIDE

CIRCUIT IS SUBJECT TO CHANGE FOR IMPROVEMENT.

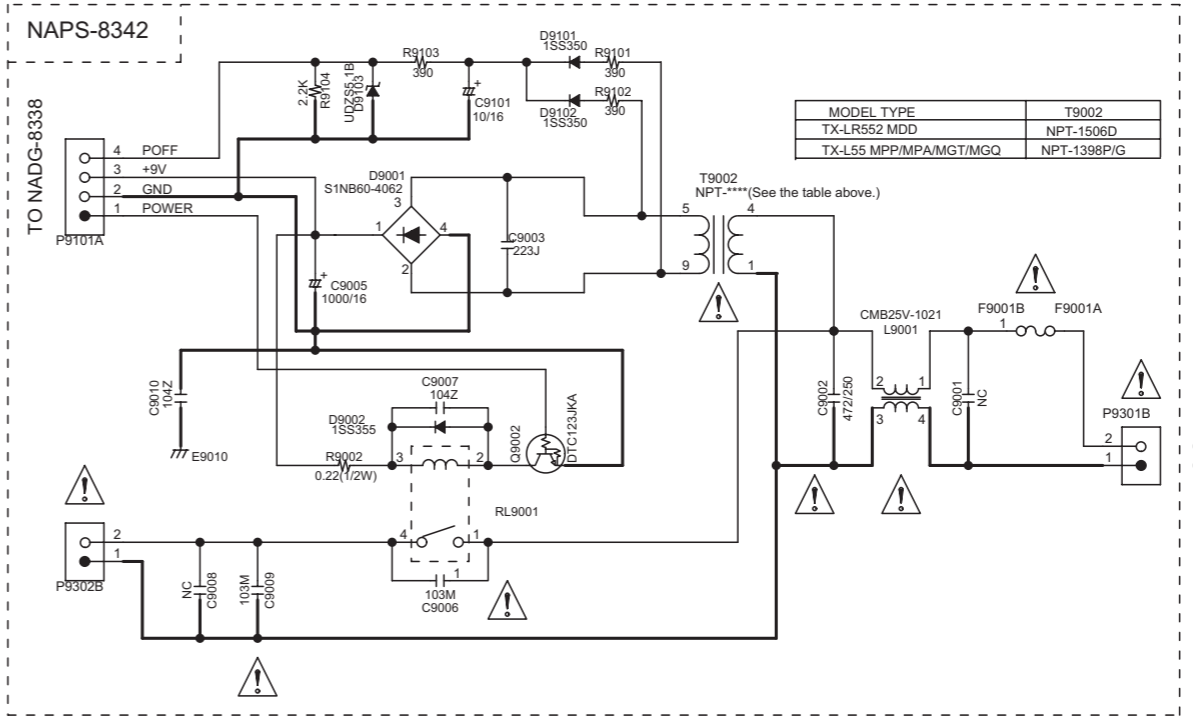
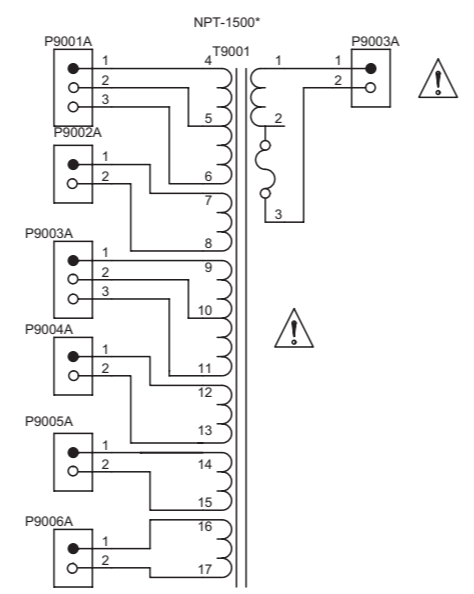

	FUSE RATING	Region
TX-LR552	2.5A/250V	120V models
TX-L55	1.6A/125V	Other models

SCHEMATIC DIAGRAM 5 Amplifier section 2

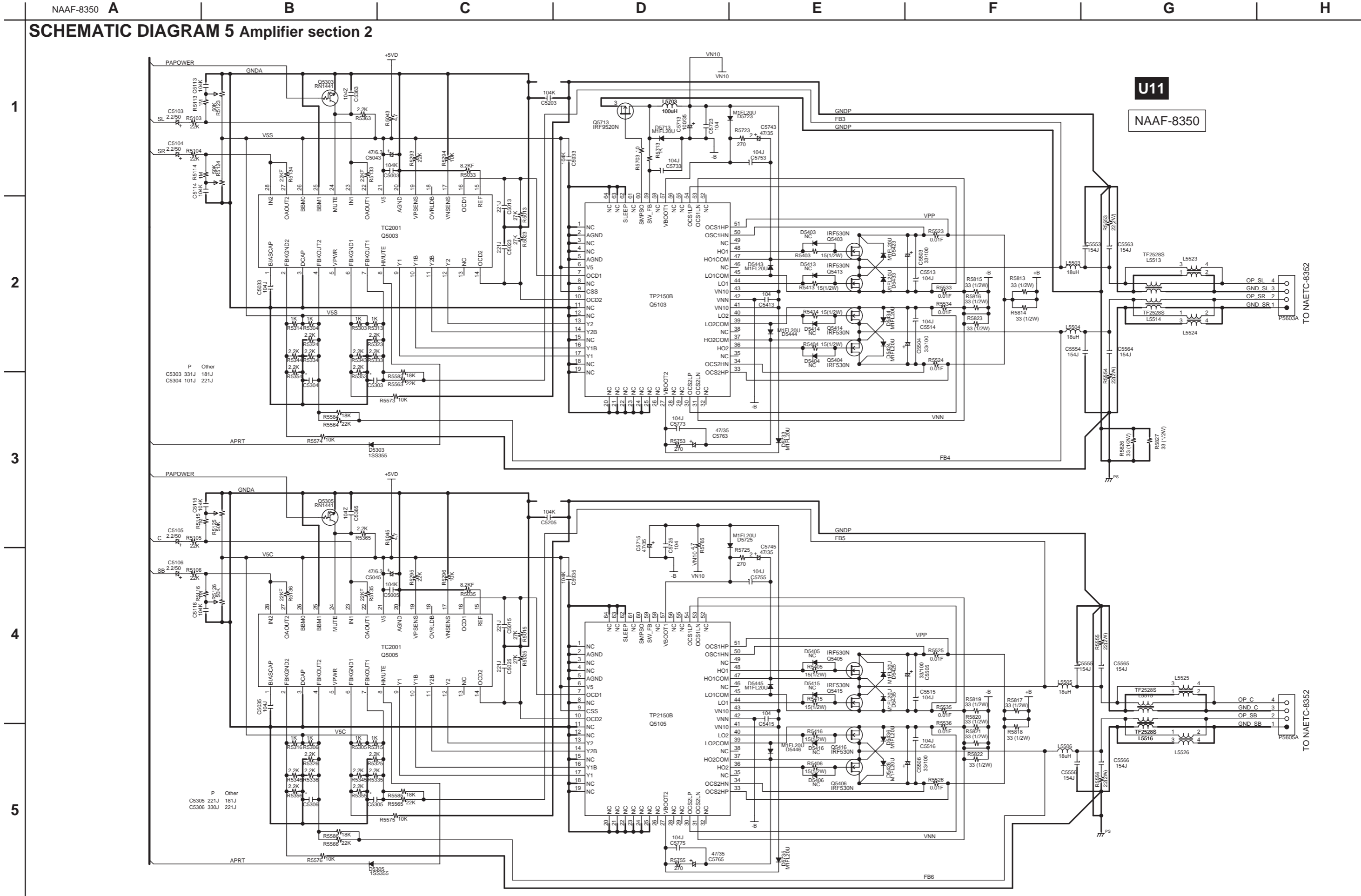

1

2

3

4

5

U11
NAAF-8350

TO NAE/C-8352

TO NAE/C-8352

A

B

C

D

PC BOARD-CONNECTION DIAGRAM

1

2

3

4

5

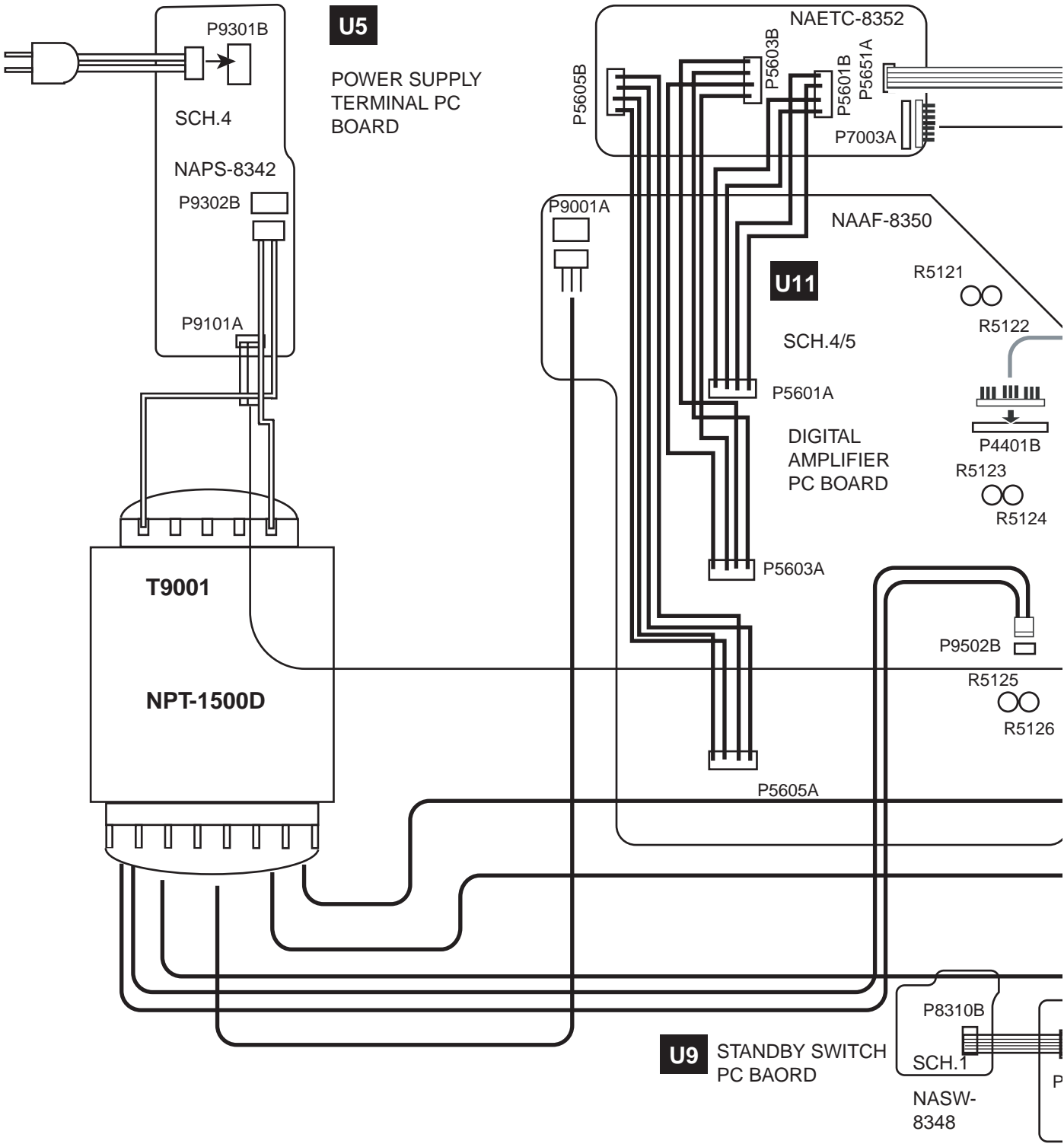

A B C D

PC BOARD-CONNECTION DIAGRAM

1
2
3
4
5

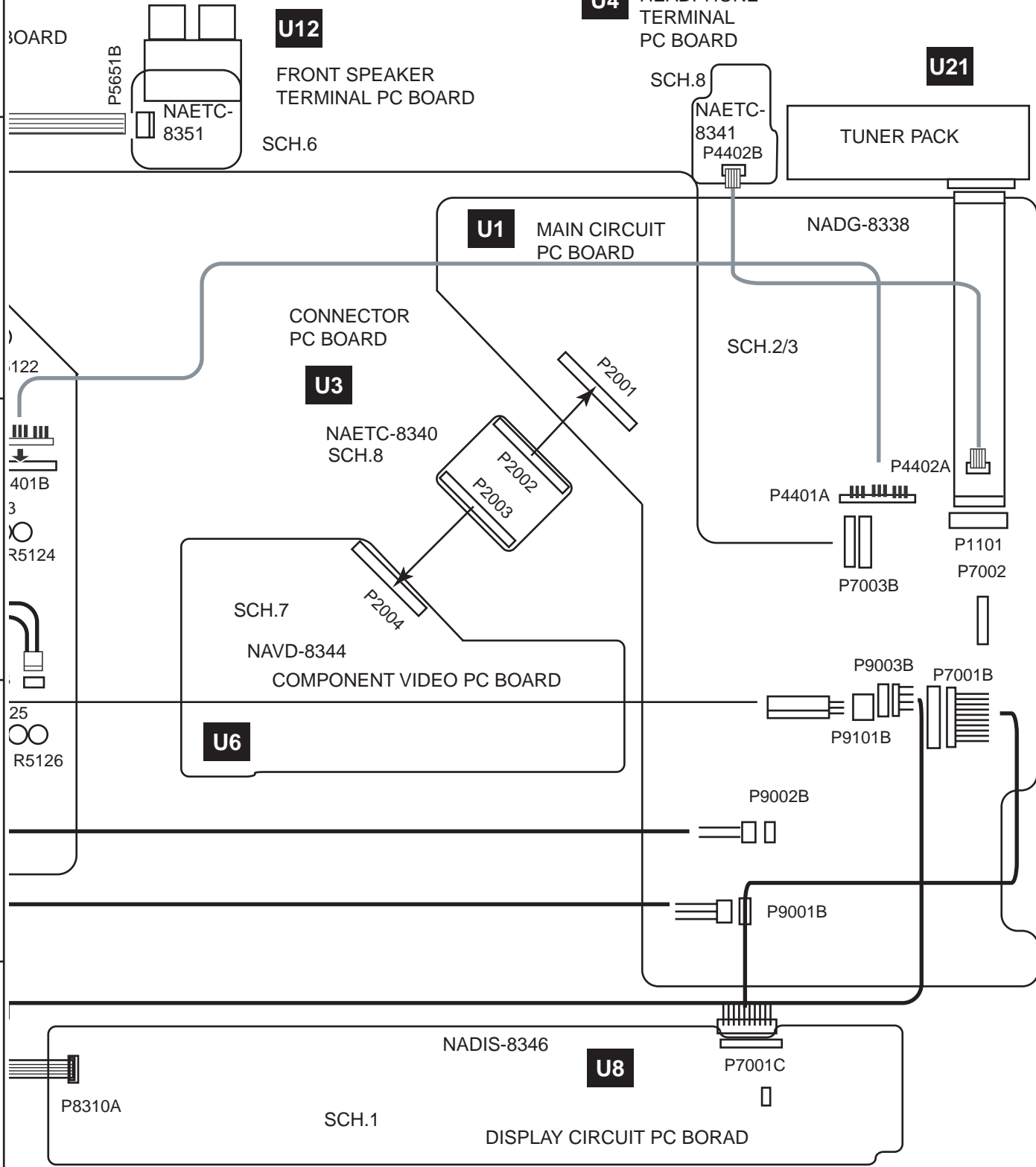

A

B

C

D

PC BOARD-CONNECTION DIAGRAM

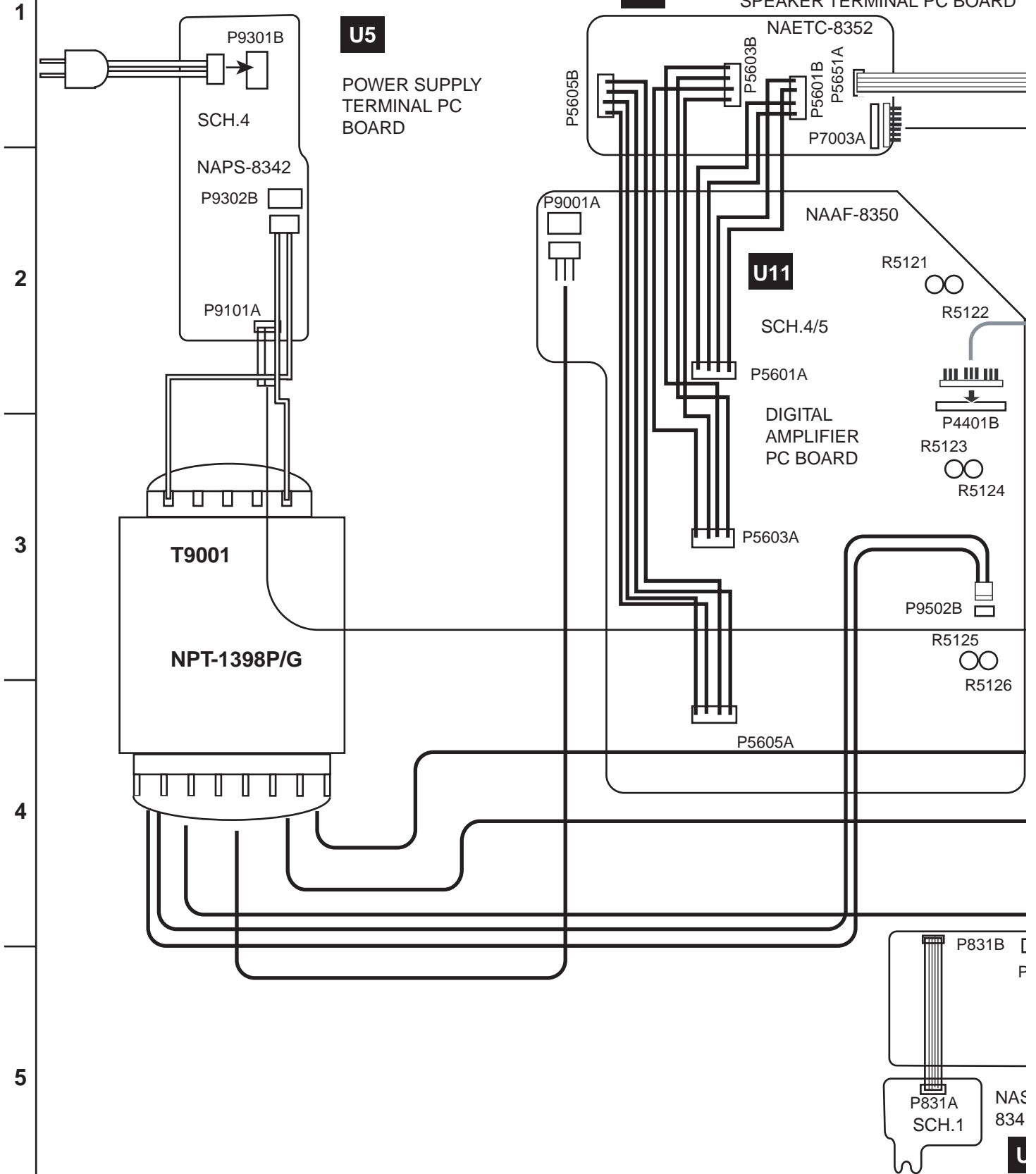

A

B

C

D

PC BOARD-CONNECTION DIAGRAM

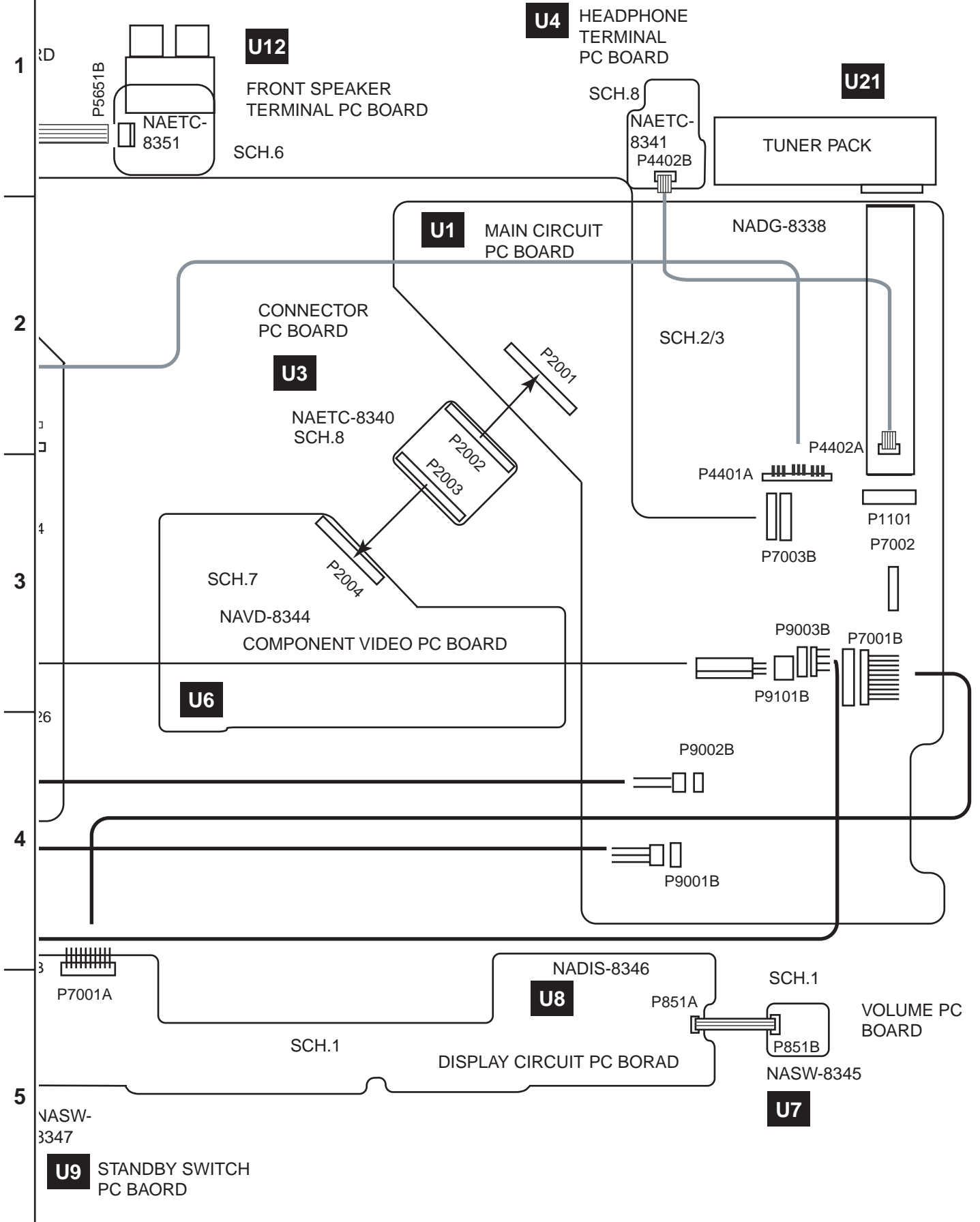

PRINTED
CIRCUIT
BOARD
VIEW
from
Component
side
(NAPS-8342)

1

2

3

4

5

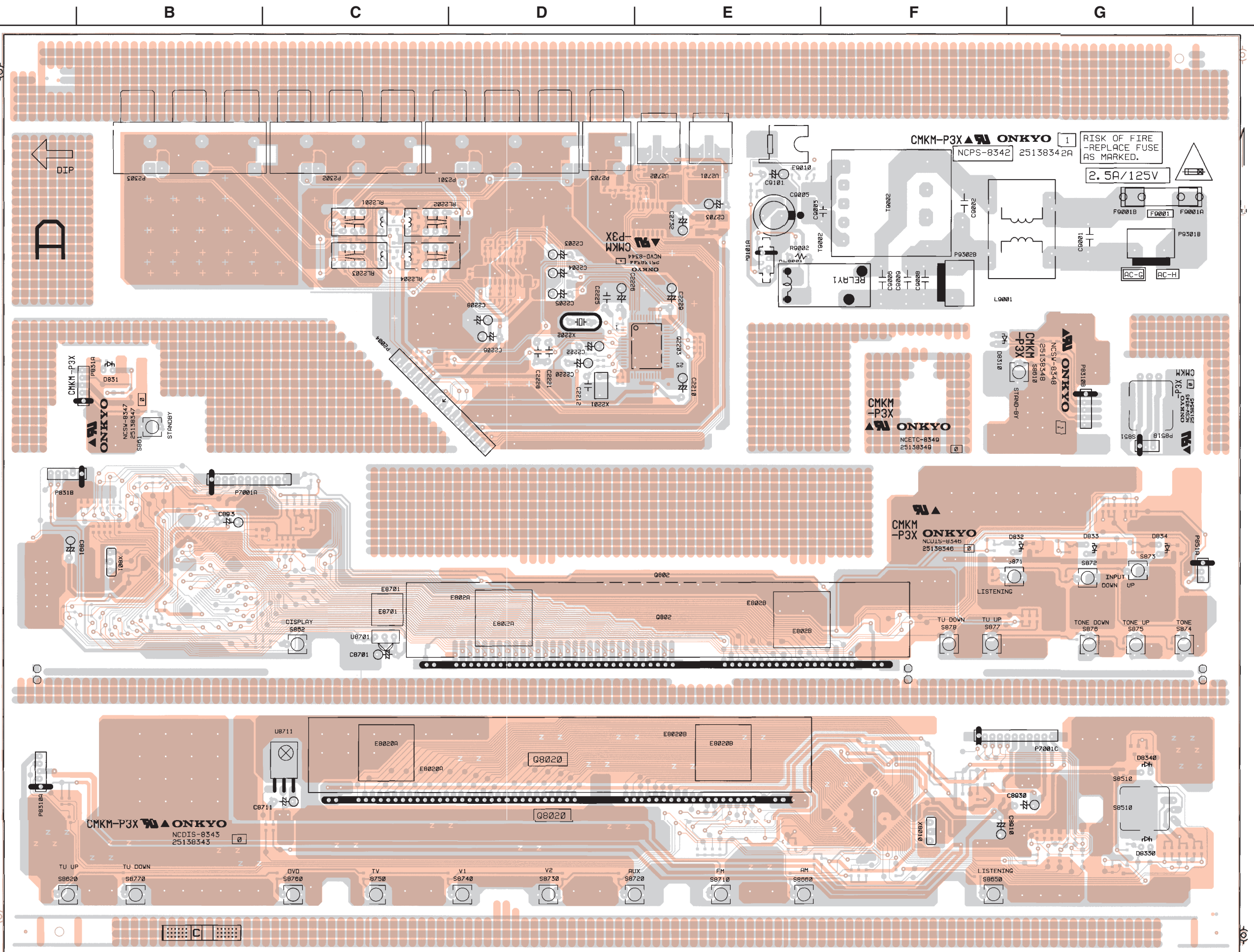

IC BLOCK DIAGRAMS AND DESCRIPTIONS

BD3817KS (7ch Volume with 10ch input selector)

BLOCK DIAGRAM

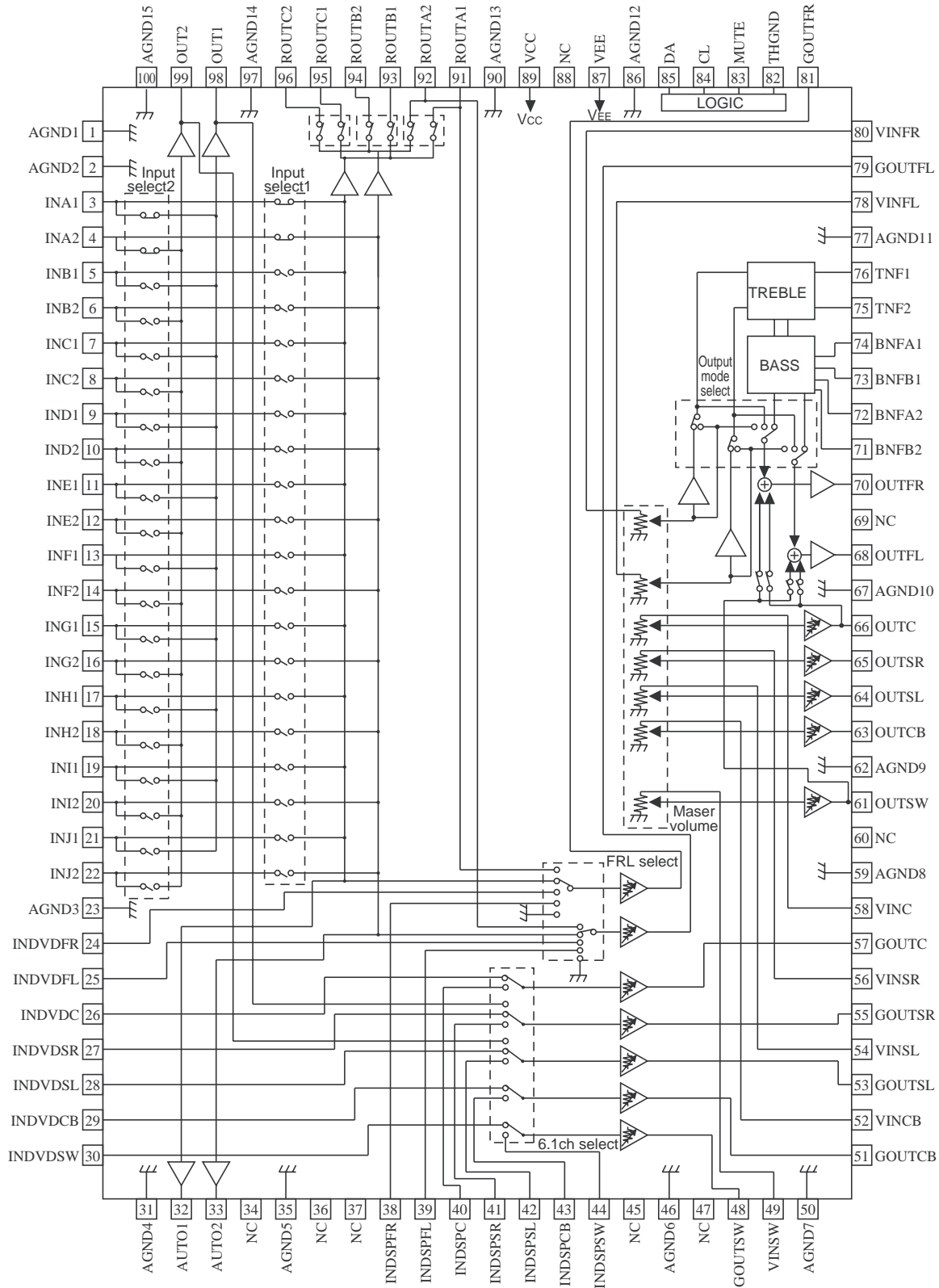

IC BLOCK DIAGRAMS AND DESCRIPTIONS

BD3817KS (7ch Volume with 10ch input selector)

TERMINAL DESCRIPTION

Pin No.	Pin Name	Description
1	AGND1	Analog ground terminal
2	AGND2	Analog ground terminal
3	INA1	1ch input terminal A
4	INA2	2ch input terminal A
5	INB1	1ch input terminal B
6	INB2	2ch input terminal B
7	INC1	1ch input terminal C
8	INC2	2ch input terminal C
9	IND1	1ch input terminal D
10	IND2	2ch input terminal D
11	INE1	1ch input terminal E
12	INE2	2ch input terminal E
13	INF1	1ch input terminal F
14	INF2	2ch input terminal F
15	ING1	1ch input terminal G
16	ING2	2ch input terminal G
17	INH1	1ch input terminal H
18	INH2	2ch input terminal H
19	INI1	1ch input terminal I
20	INI2	2ch input terminal I
21	INJ1	1ch input terminal J
22	INJ2	2ch input terminal J
23	AGND3	Analog ground terminal
24	INDVDFR	FRch DVD input terminal
25	INDVDFL	FLch DVD input terminal
26	INDVDC	Cch DVD input terminal
27	INDVDSR	SRch DVD input terminal
28	INDVDSL	SLch DVD input terminal
29	INDVDCB	CBch DVD input terminal
30	INDVDSW	SWch DVD input terminal
31	AGND4	Analog ground terminal
32	AOUT1	1ch A/D output terminal
33	AOUT2	2ch A/D output terminal
34	NC	Non-connected terminal
35	AGND5	Analog ground terminal
36	NC	Non-connected terminal
37	NC	Non-connected terminal
38	INDSPFR	FRch DSP input terminal
39	INDSPFL	FLch DSP input terminal
40	INDSPC	Cch DSP input terminal
41	INDSPSR	SRch DSP input terminal
42	INDSPSL	SLch DSP input terminal
43	INDSPCB	CBch DSP input terminal
44	INDSPSW	SWch DSP input terminal
45	NC	Non-connected terminal
46	AGND6	Analog ground terminal
47	NC	Non-connected terminal
48	GOUTSW	SWch input gain output terminal
49	VINSW	SWch volume input terminal
50	AGND7	Analog ground terminal

Pin No.	Pin name	Description
51	GOUTCB	CBch input gain output terminal
52	VINCB	CBch volume input terminal
53	GOUTSL	SLch input gain output terminal
54	VINSL	SLch volume input terminal
55	GOUTSR	SRch input gain output terminal
56	VINSR	SRch volume input terminal
57	GOUTC	Cch input gain output terminal
58	VINC	Cch volume input terminal
59	AGND8	Analog ground terminal
60	NC	Non-connected terminal
61	OUTSW	SWch output terminal
62	AGND9	Analog ground terminal
63	OUTCB	CBch output terminal
64	OUTSL	SLch output terminal
65	OUTSR	SRch output terminal
66	OUTC	Cch output terminal
67	AGND10	Analog ground terminal
68	OUTFL	FLch output terminal
69	NC	Non-connected terminal
70	OUTFR	FRch output terminal
71	BNFB2	2ch bass filter terminal B
72	BNFA2	2ch bass filter terminal A
73	BNFB1	1ch bass filter terminal B
74	BNFA1	1ch bass filter terminal A
75	TNF2	2ch treble filter terminal
76	TNF1	1ch treble filter terminal
77	AGND11	Analog ground terminal
78	VINFL	FLch volume input terminal
79	GOUTFL	FLch input gain output terminal
80	VINFR	FRch volume input terminal
81	GOUTFR	FRch input gain output terminal
82	THGND	Comparator ground terminal
83	MUTE	Mute terminal
84	CL	Serial clock input terminal
85	DA	Serial data and latch input terminal
86	AGND12	Analog ground terminal
87	VEE	(-)Power supply terminal
88	NC	Non-connected terminal
89	VCC	(+)Power supply terminal
90	AGND13	Analog ground terminal
91	ROUTA1	1ch REC input and output terminal A
92	ROUTA2	2ch REC input and output terminal A
93	ROUTB1	1ch REC output terminal B
94	ROUTB2	2ch REC output terminal B
95	ROUTC1	1ch REC output terminal C
96	ROUTC2	2ch REC output terminal C
97	OUT1	1ch output terminal
98	OUT2	2ch output terminal
99	AGND14	Analog ground terminal
100	AGND15	Analog ground terminal

IC BLOCK DIAGRAMS AND TERMINAL DESCRIPTIONS

BU1924FS (RDS Decoder) <European model only>

BLOCK DIAGRAM

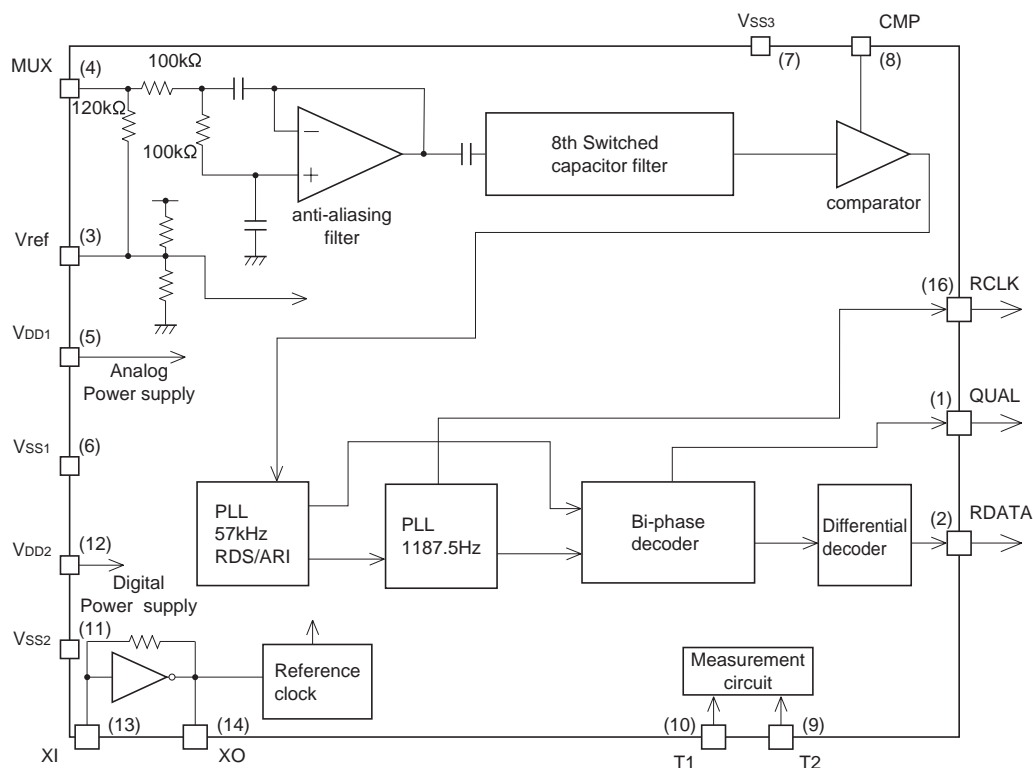

TERMINAL DESCRIPTION

Pin No.	Pin name	Description
1	QUAL	Output terminal of demodulator quality signal.
2	RDATA	Output terminal of demodulator data.
3	Vref	Input terminal of reference voltage.
4	MUX	Input terminal of composite signal.
5	VDD1	Analog power supply.
6	VSS1	Analog power supply.
7	VSS3	Ground.
8	CMP	Input terminal of comparator.
9	T2	Input terminal for test mode.
10	T1	Input terminal for test mode.
11	VSS2	Digital power supply.
12	VDD2	Digital power supply.
13	XI	Connect to oscillator.
14	XO	Connect to oscillator.
15	(N.C.)	---
16	RCLK	Output terminal of demodulator clock.

IC BLOCK DIAGRAMS AND DESCRIPTIONS

CS494003(Audio Decoder DSP)

BLOCK DIAGRAM

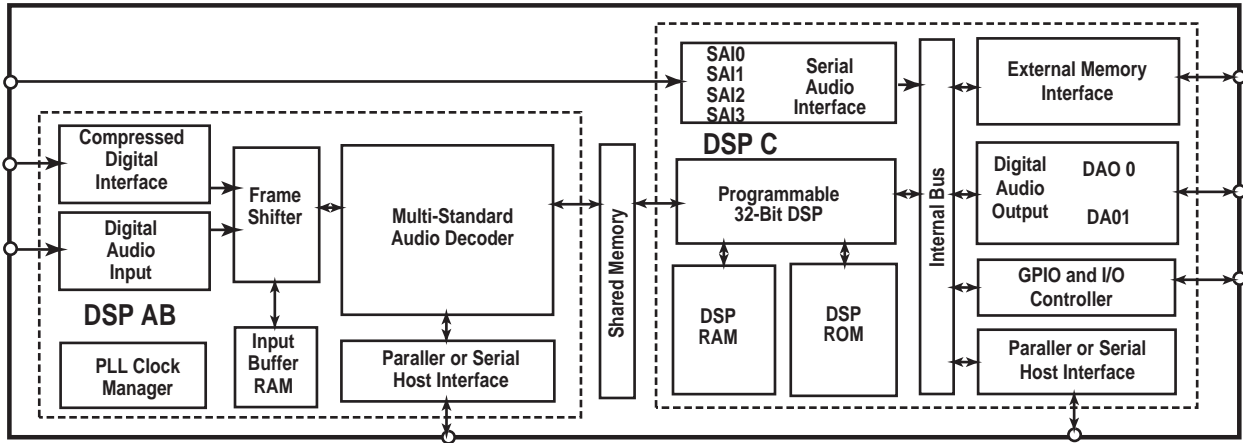

UHS0, GPIO18	LRCLK0	AUDATA1	SD_ADDR10, EXTA10
UHS1, GPIO19	AUDATA2	AUDATA0	SD_BA, EXTA19
INTREQ	AUDATA3, XMT958A	CMPLK, FSCLKN2	VDDSD1
FA1, FSCDIN	005 HDATA3, GPIO3	HDATA2, GPIO2	VSSSD1
GPIO20	SCLK0	VSS3	SD_CS
FA0, FSCCLK	HDATA4, GPIO4	VDD3	SD_ADDR4, EXTA4
FA0, FSCDOUT	AUDATA4, GPIO28	HDATA1, GPIO1	SD_ADDR5, EXTA5
GPIO21	VSS2	HDATA0, GPIO0	65 SD_ADDR6, EXTA6
FDAT7	VDD2	CMPPREQ, FLRCLKN2	SD_CLK_EN
VDD6	MCLK	CMPPDAT, FSDATAN2	SD_ADDR7, EXTA7
VSS6	SCLK1	FLRCLKN1	SD_ADDR8, EXTA8
FHS0, FWR, FDS	HDATA5, GPIO5	WR, DS, GPIO10	SD_CLK_IN
FHS1, FRD, FRW	HDATA6, GPIO6	RD, R/W, GPIO11	60 SD_ADDR9, EXTA9
FRD, FRW	HDATA7, GPIO7	PLL VSS	SD_CLK_OUT
FDAT6	051 HDATA5, GPIO29	FILT2	VDDSD2
FINTREQ	AUDATA6, GPIO30	FILT1	VSSSD2
FBCCK	AUDATA7, XMT958B, GPIO31	PLL VDD	SD_DATA8, EXTA11
FDAT5	VSS1	XTALO	55 SD_DATA9, EXTA12
FDAT4	VDD1	CLKIN, XTALI	SD_DATA10, EXTA13
VDD7	NC1	CLKSEL	SD_DATA11, EXTA14
VSS7	NC2	CS, GPIO9	SD_DATA12, EXTA15
FDAT3	LRCLK1	A0, GPIO13	VDDSD3
FDBDA	SCLKN, GPIO22	FSDATAN1	50 VSSSD3
FDAT2	SCLKN, GPIO23	VDD4	SD_DATA13, EXTA16
DBDA	NC3	VSS4	NC5
DBCK	NC4	FSCCLKN1, STCCLK2	SD_DATA14, EXTA17
TEST	SDATAN0, GPIO24	SCS	SD_DATA15, EXTA18
FDAT0	SDATAN1, GPIO25	SCDIN	45 SD_DQM1
NV_WE, GPIO16	80 SDATAN2, GPIO26	VSS5	SD_DATA7, EXT7
NV_OE, GPIO15	SDATAN3, GPIO27	VDD5	SD_DATA6, EXT6
NV_CS, GPIO14	SD_CS	A1, GPIO12	VDDSD4
SD_DATA0, EXT0	SD_RAS	SCDOUT, SCDIO	VSSSD4
SD_DATA1, EXT1	SD_ADDR3, EXTA3	HINBSY, GPIO8	40 SD_DATA5, EXT5
SD_DATA2, EXT2	75 SD_ADDR2, EXTA2	SCCLK	SD_DQM0
	SD_ADDR1, EXTA1	UHS2, CS_OUT, GPIO17	SD_DATA4, EXT4
	SD_ADDR0, EXTA0	RESET	SD_DATA3, EXT3

IC BLOCK DIAGRAMS AND DESCRIPTIONS

CS494003(Audio Decoder DSP)

FILT1 - Phase-Locked Loop Filter
 FILT2 - Phase Locked Loop Filter
 CLKIN, XTALI - External Clock Input/Crystal Oscillator Input
 XTALO - Crystal Oscillator Output
 CLKSEL - DSP Clock Select
 FDAT0~FDAT7 - DSPAB Bidirectional Data Bus
 FA0, FSCCLK - Host Parallel Address Bit Zero or Serial Control Port Clock
 FA1, FSCDIN - Host Address Bit One or SPI Serial Control Data Input
 FHS1, \overline{FRD} , $\overline{FR\overline{W}}$ - Mode Select Bit 1 or Host Parallel Output Enable or Host Parallel R/W
 FHS0, \overline{FWR} , \overline{FDS} - Mode Select Bit 0 or Host Write Strobe or Host Data Strobe
 FCS - Host Parallel Chip Select, Host Serial SPI Chip Select
 FHS2, FSCDIO, FSCDOUT - Mode Select Bit 2 or Serial Control Port Data Input and Output, Parallel Port Type Select
 $\overline{FINTREQ}$ - Control Port Interrupt Request
 FSCLKN1, STCCLK2 - PCM Audio Input Bit Clock
 FLRCLKN1 - PCM Audio Input Sample Rate Clock
 FSDATAN1 - PCM Audio Data Input One
 CMPCLK, FSCLKN2 - PCM Audio Input Bit Clock
 CMPDAT, FSDATAN2 - PCM Audio Data Input Number Two
 FDBCK - Reserved
 FDBDA - Reserved
 PLLVDD - PLL Supply Voltage
 PLLVSS - PLL Ground Voltage
 RESET - Master Reset Input
 TEST - Reserved
 MCLK - Audio Master Clock
 SCLK0 - Audio Output Bit Clock
 SCLK1 - Audio Output Bit Clock
 LRCLK0 - Audio Output Sample Rate Clock
 LRCLK1 - Audio Output Sample Rate Clock
 AUDATA0 - Digital Audio Output 0
 AUDATA1 - Digital Audio Output 1
 AUDATA2 - Digital Audio Output 2
 AUDATA3, XMT958A - Digital Audio Output 3, S/PDIF Transmitter
 AUDATA4, GPIO28 - Digital Audio Output 4, General Purpose I/O
 AUDATA5, GPIO29 - Digital Audio Output 5, General Purpose I/O
 AUDATA6, GPIO30 - Digital Audio Output 6, General Purpose I/O
 AUDATA7, XMT958B, GPIO3 - Digital Audio Output 7, S/PDIF Transmitter, General Purpose I/O
 DBCK - Debug Clock
 DBDA - Debug Data
 SLCKN, GPIO22 - PCM Audio Input Bit Clock, General Purpose I/O
 LRCLKN, GPIO23 - PCM Audio Input Sample Rate Clock, General Purpose I/O
 SDATAN0, GPIO24 - PCM Audio Input Data, General Purpose I/O
 SDATAN1, GPIO25 - PCM Audio Input Data, General Purpose I/O
 SDATAN2, GPIO26 - PCM Audio Input Data, General Purpose I/O
 SDATAN3, GPIO27 - PCM Audio Input Data, General Purpose I/O
 \overline{SCS} - Host Serial SPI Chip Select
 SCCLK - Serial Control Port Clock
 SCDIN - SPI Serial Control Data Input
 SCDOOUT, SCADIO - Serial Control Port Data Input and Output
 \overline{INTREQ} - Control Port Interrupt Request
 HDATA1~HDATA7, GPIO1~GPIO7 - DSPC Bidirectional Data Bus, General Purpose I/O
 A0, GPIO13 - Host Parallel Address Bit 0, General Purpose I/O
 A1, GPIO12 - Host Address Bit 1, General Purpose I/O
 \overline{RD} , $\overline{R\overline{W}}$, GPIO11 - Host Parallel Output Enable, Host Parallel R/W, General Purpose I/O
 \overline{WR} , \overline{DS} , GPIO10 - Host Write Strobe, Host Data Strobe, General Purpose I/O
 \overline{CS} , GPIO9 - Host Parallel Chip Select, General Purpose I/O
 HINBSY, GPIO8 - Input Host Message Status, General Purpose I/O
 SD_DATA8~SD_DATA15, EXTA11~EXTA18 - SDRAM Data Bus, SRAM External Address Bus
 SD_DATA0~SD_DATA7, EXTDO~EXTD7 - SDRAM Data Bus, SRAM External Data Bus
 SD_ADDR0~SD_ADDR10, EXTA0~EXTA10 - SDRAM Address Bus, SRAM External Address Bus
 SD_CLK_OUT - SDRAM Clock Output
 SD_CLK_IN - SDRAM Re-timing Clock Input
 SD_CLK_EN - SDRAM Clock Enable
 SD_BA, EXTA19 - SDRAM Bank Address Select, SRAM External Address Bus
 $\overline{SD_CS}$ - SDRAM Chip Select
 $\overline{SD_RAS}$ - SDRAM Row Address Strobe
 $\overline{SD_CAS}$ - SDRAM Column Address Strobe
 $\overline{SD_WE}$ - SDRAM Write Enable
 SD_DQM1 - SDRAM Data Mask 1
 SD_DQM0 - SDRAM Data Mask 2
 $\overline{NV_CS}$, GPIO14 - SRAM Chip Select, General Purpose I/O
 $\overline{NV_OE}$, GPIO15 - SRAM Output Enable, General Purpose I/O
 $\overline{NV_WE}$, GPIO16 - SRAM Write Enable, General Purpose I/O
 UHS2, CS_OUT, GPIO17 - Mode Select Bit 2, External Serial Memory Chip Select, General Purpose I/O
 UHS0, GPIO18 - Mode Select Bit 0, General Purpose I/O
 UHS1, GPIO19 - Mode Select Bit 1, General Purpose I/O
 GPIO20 - General Purpose I/O
 GPIO21 - General Purpose I/O
 VSS - 2.5V Ground
 NC[5:1] - No Connect
 VDDSD[4:1] - 3.3V SDRAM/SRAM/EPROM Interface Supply
 VDD[7:1] - 2.5V Supply Voltage
 VSSSD - 3.3V SDRAM/SRAM/EPROM Interface Ground

IC BLOCK DIAGRAMS AND TERMINAL DESCRIPTIONS(LR552 only)

LA7106MFP(75 ohm video driver)

BLOCK DIAGRAM

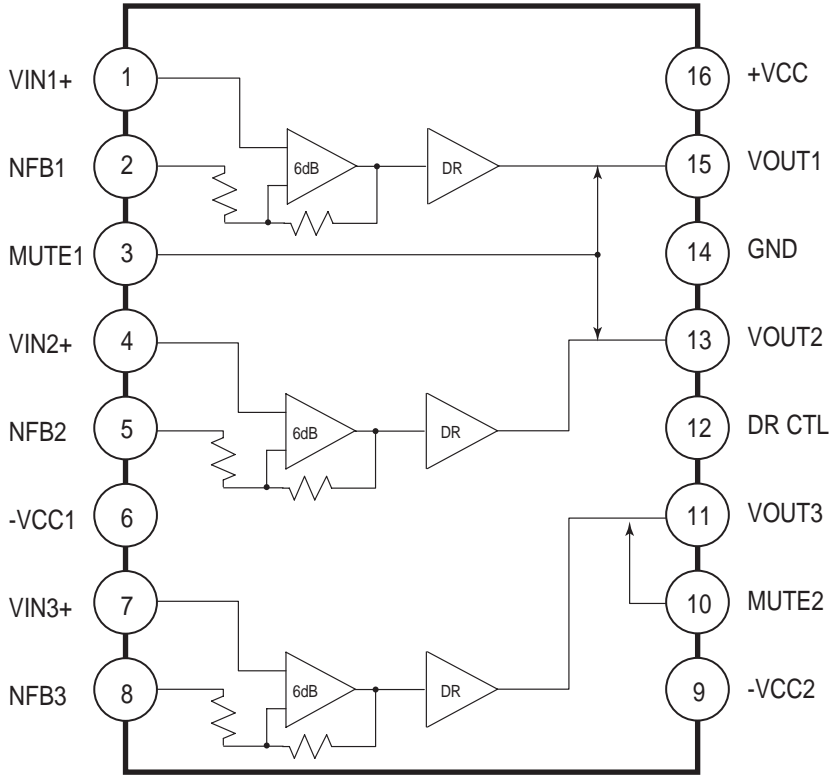

MM1512(Y-C mixer circuit)

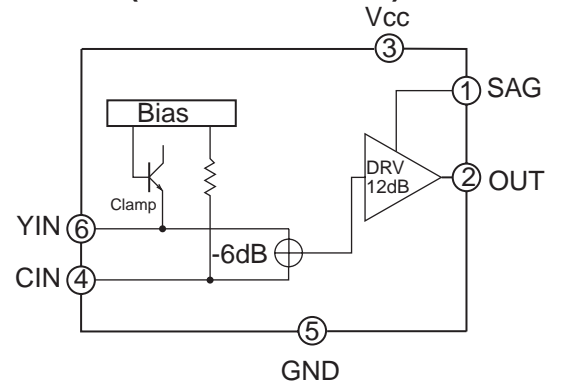

MM1093NF(4fsc clock generator)

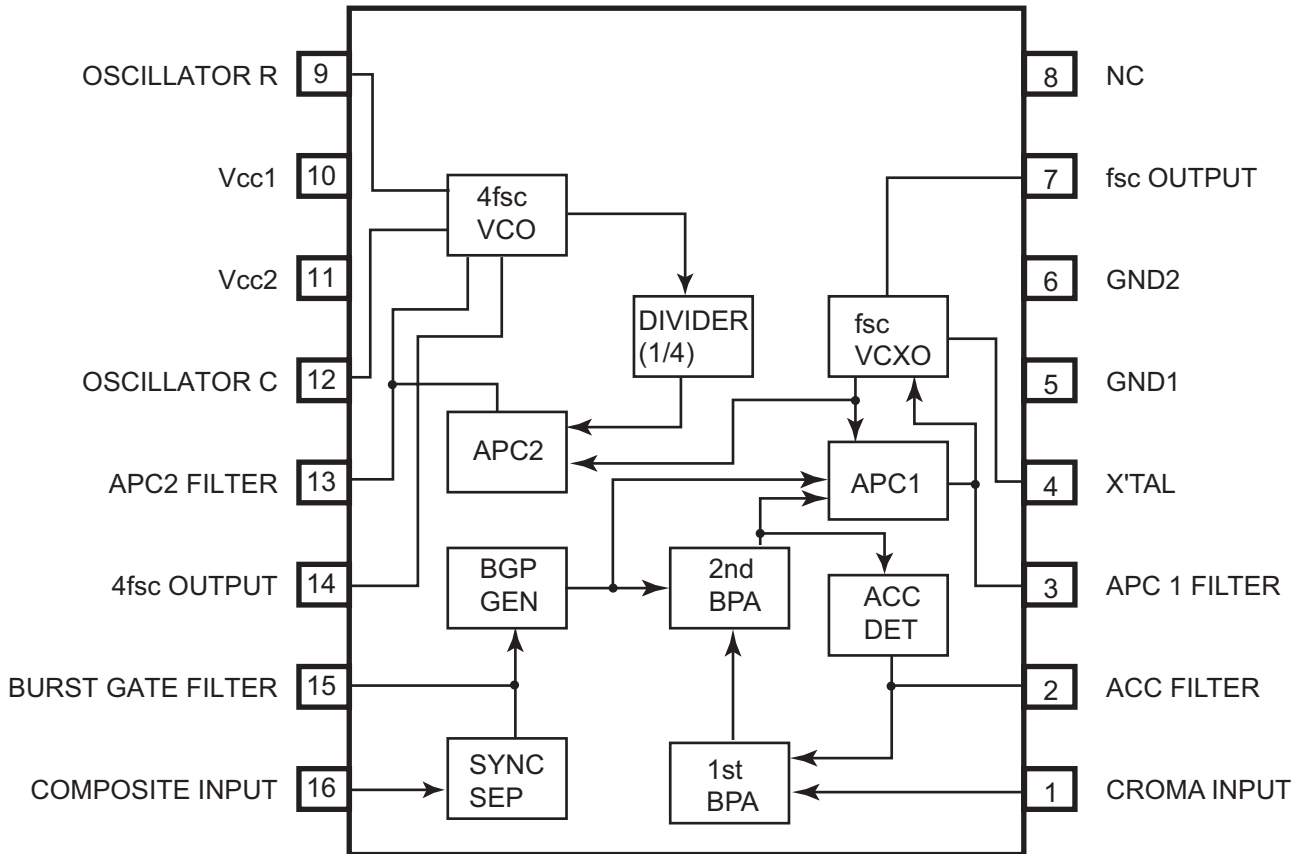

IC BLOCK DIAGRAMS AND TERMINAL DESCRIPTIONS

MX29LV040 (4M-Bit CMOS Single Voltage 3V Only Equal Sector Flash Memory)

BLOCK DIAGRAM

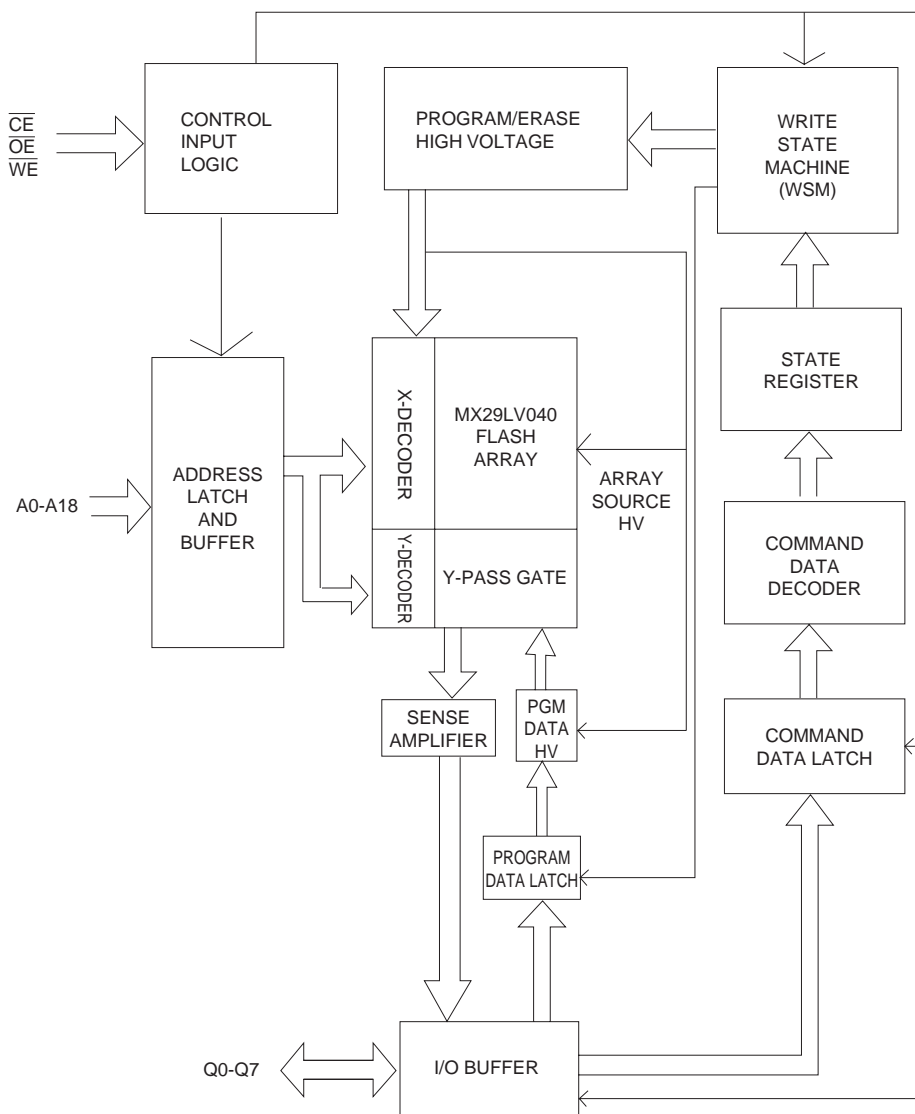

TERMINAL DESCRIPTION

PIN LAYOUT

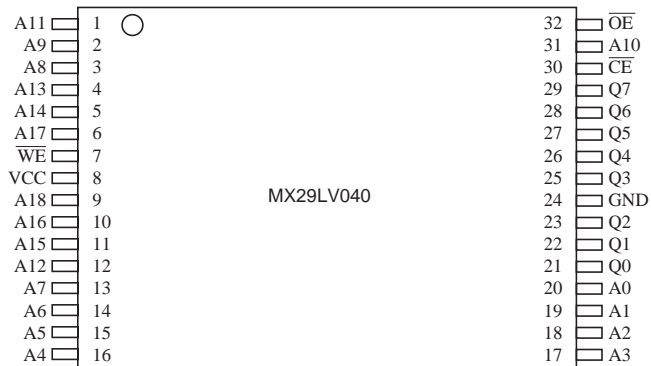

Pin Name	Description
A0~A18	Address Input
Q0~Q7	Data Input/Output
\overline{CE}	Chip Enable Input
\overline{WE}	Write Enable Input
\overline{OE}	Output Enable Input
GND	Ground Pin
VCC	+3.0V single power supply

IC BLOCK DIAGRAMS AND TERMINAL DESCRIPTIONS

NJM2279 (3 Input/2 Output Video Switch)

BLOCK DIAGRAM

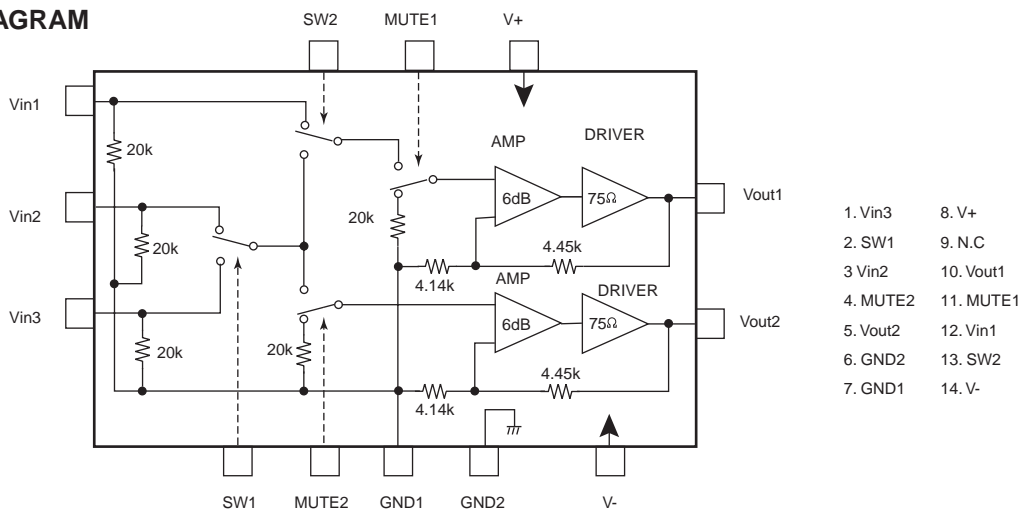

TC90A69F (COM Filter)

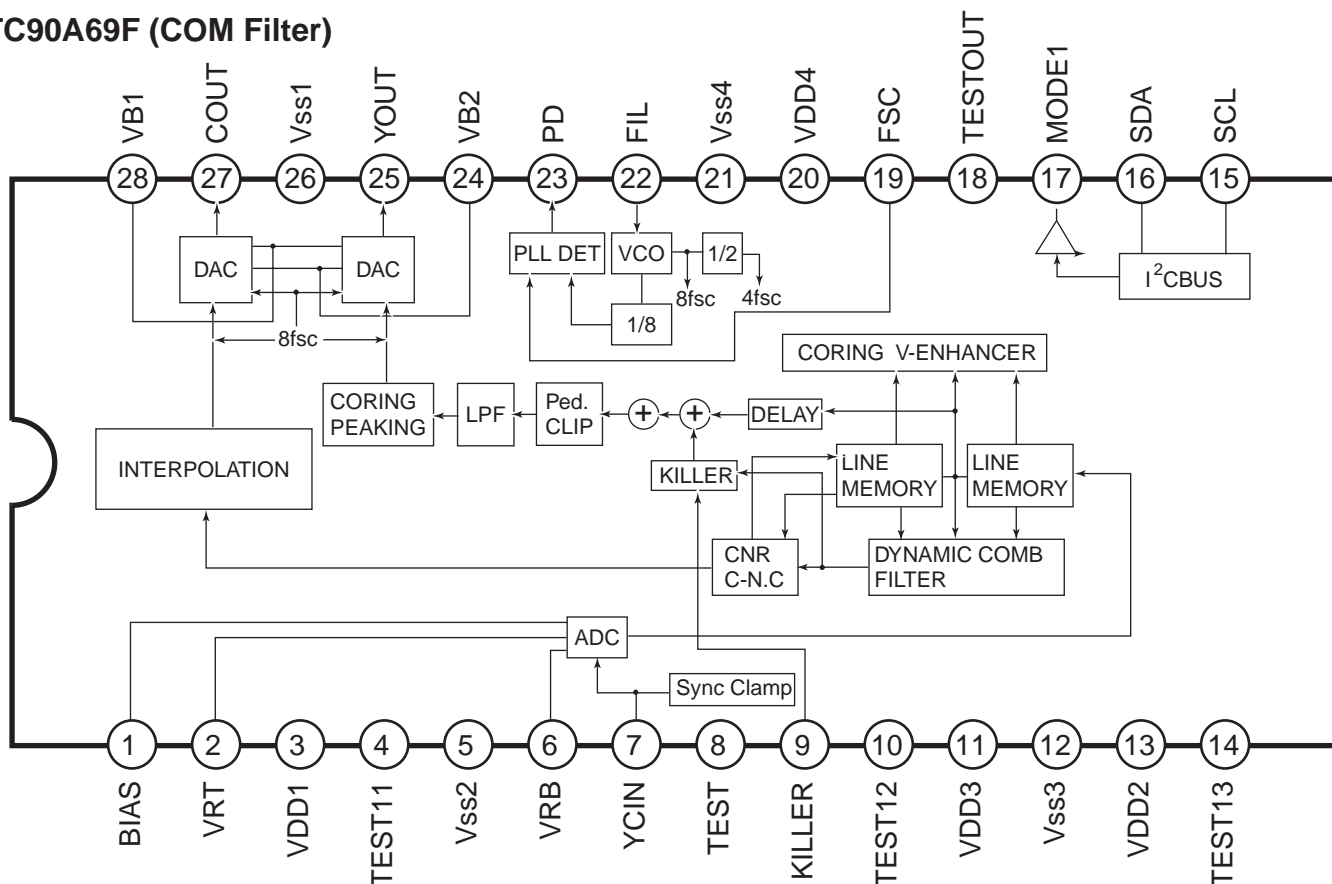

Pin	Symbol	Function	Pin	Symbol	Function
1	BIAS	Bias for ADC	15	SCL	Clock input of I2C Bus
2	VRT	Maximum bias of D range for ADC	16	SDA	Data input/output of I2C Bus
3	VDD1	Analog supply for ADC/DAC	17	MODE1	Mode 1 output
4	TEST1	Test input	18	TESTOUT	Test output
5	VSS2	Analog ground supply for ADC	19	FSC	Clock input of I2C Bus
6	VRB	Minimum bias of D range for ADC	20	VDD4	Analog supply for PLL
7	YCIN	Video signal input	21	VSS4	Analog ground supply for PLL
8	TEST1	Reset control and test control of initializing	22	FIL	VCO control
9	KILLER	Y/C separation and vertical enhancer off control	23	PD	PLL detection output
10	TEST2	Test input	24	VB2	Bias 2 for DAC
11	VDD3	Digital supply for logic	25	YOUT	Brightness signal output
12	VSS3	Digital ground supply for Logic/DRAM	26	VSS1	Analog ground for DAC
13	VDD2	Digital supply for DRAM	27	COUT	Color signal output
14	TEST3	Test input	28	VB1	Bias 1 for DAC

IC BLOCK DIAGRAMS AND DESCRIPTIONS

TC2100(Audio Signal Processor)

Pin Connection

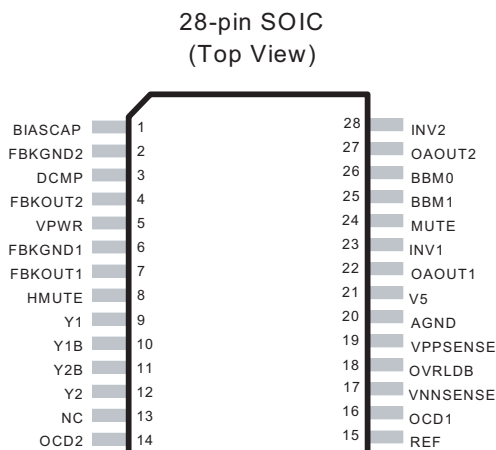

Pin Descriptions

Pin	Function	Description
1	BIASCAP	Bandgap reference times two (typically 2.5VDC). Used to set the common mode voltage for the input op amps. This pin is not capable of driving external circuitry.
2, 6	FBKGND2, FBKGND1	Ground Kelvin feedback (Channels 1 & 2)
3	DCMP	Internal mode selection. This pin must be grounded for proper device operation.
4, 7	FBKOUT2, FBKOUT1	Switching feedback (Channels 1 & 2)
5	VPWR	Test pin. Must be left floating.
8	HMUTE	Logic output. A logic high indicates both amplifiers are muted, due to the mute pin state, or a "fault".
9, 12	Y1, Y2	Non-inverted switching modulator outputs.
10, 11	Y1B, Y2B	Inverted switching modulator outputs.
13	NC	No connect
14, 16	OCD2, OCD1	Over Current Detect pins.
15	REF	Internal bandgap reference voltage; approximately 1.2 VDC.
17	VNNSENSE	Negative supply voltage sense input. This pin is used for both over and under voltage sensing for the VNN supply.
18	OVRLDB	A logic low output indicates the input signal has overloaded the amplifier.
19	VPPSENSE	Positive supply voltage sense input. This pin is used for both over and under voltage sensing for the VPP supply.
20	AGND	Analog Ground.
21	V5	5 Volt power supply input.
22, 27	OAOUT1, OAOUT2	Input stage output pins.
23, 28	INV1, INV2	Single-ended inputs. Inputs are a "virtual" ground of an inverting opamp with approximately 2.4VDC bias.
24	MUTE	When set to logic high, both amplifiers are muted and in idle mode. When low (grounded), both amplifiers are fully operational. If left floating, the device stays in the mute mode. Ground if not used.
25, 26	BBM1, BBM0	Break-before-make timing control to prevent shoot-through in the output MOSFETs.

IC BLOCK DIAGRAMS AND DESCRIPTIONS

TC2150(Digital Power Amplifier Driver)

Pin Connection

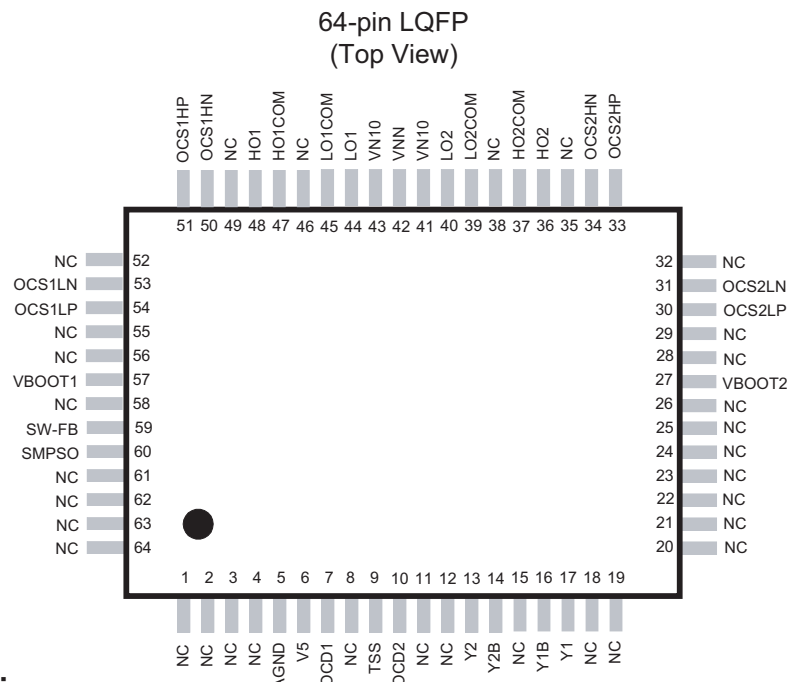

Pin Description

Pin	Function	Description
5	AGND	Analog ground.
6	V5	5V power supply input.
7	OCD1	Over-current threshold output (Channel 1)
9	TSS	This a test pin for the TP2350B. This pin should be left floating.
10	OCD2	Over-current threshold output (Channel 2)
13,17	Y2, Y1	Non-inverted switching modulator inputs
14,16	Y2B, Y1B	Inverted switching modulator inputs
27,57	VBOOT2, VBOOT1	Bootstrapped voltage to supply drive to gate of high-side FET (Channel 2 & 1)
30,31	OCS2LP, OCS2LN	Over Current Sense inputs, Channel 2 low-side
33,34	OCS2HP, OCS2HN	Over Current Sense inputs, Channel 2 high-side
36,48	HO2, HO1	High side gate drive output (Channel 2 & 1)
37,47	HO2COM, HO1COM	Kelvin connection to source of high-side transistor (Channel 2 & 1)
39,45	LO2COM, LO1COM	Kelvin connection to source of low-side transistor (Channel 2 & 1)
40,44	LO2, LO1	Low side gate drive output (Channel 2 & 1)
41,43	VN10	"Floating" supply input for the FET drive circuitry. This voltage must be stable and referenced to VNN.
42	VNN	Negative supply voltage.
50,51	OCS1HN, OCS1HP	Over Current Sense inputs, Channel 1 high-side
53,54	OCS1LN, OCS1LP	Over Current Sense inputs, Channel 1 low-side
59	SW-FB	Feedback for regulating switching power supply output for VN10
60	SMP SO	Switching power supply output for VN10
1,2,3,4,8, 11,12,15, 18,19,20, 21,22,23, 24,25,26, 28,29,32, 35,38,46, 49,52,55, 56,58,61, 62,63,64	NC	Not connected (bonded) internally. Leave these pins floating.

IC BLOCK DIAGRAMS AND DESCRIPTIONS

74HCU04F (Hex Inverter)

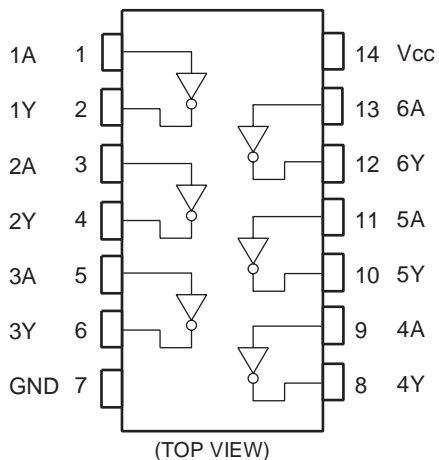

Truth table

A	Y
L	H
H	L

TC74HCT7007A (Hex Buffer)

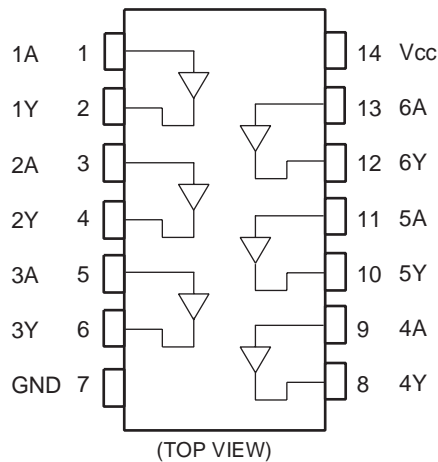

Truth table

A	Y
L	L
H	H

TC74VHC541FT (Octal Bus Buffer)

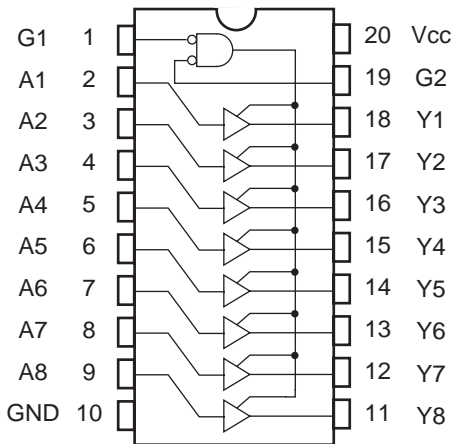

INPUTS			OUTPUT
$\overline{G1}$	$\overline{G2}$	A_n	
H	X	X	Z
X	H	X	Z
L	L	H	H
L	L	L	L

X :Don't care
Z :High impedance

TC7WU04FU (Buffer)

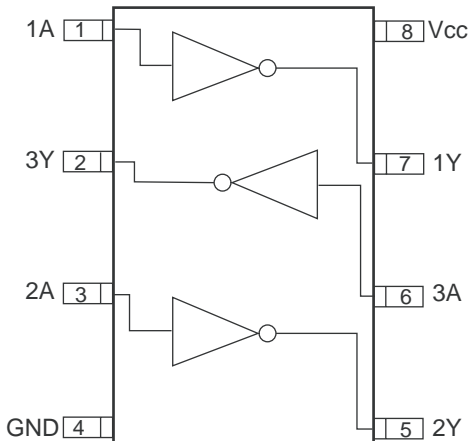

Truth Table

A	Y
L	H
H	L

TK15420 (Operation Amplifier)

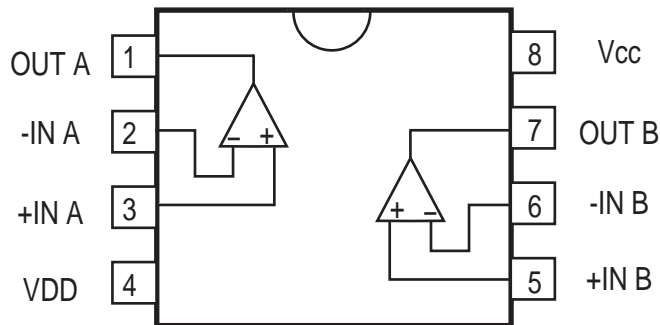

MAIN MICRO PROCESSOR-CONNECTION DIAGRAM

1
2
3
4
5

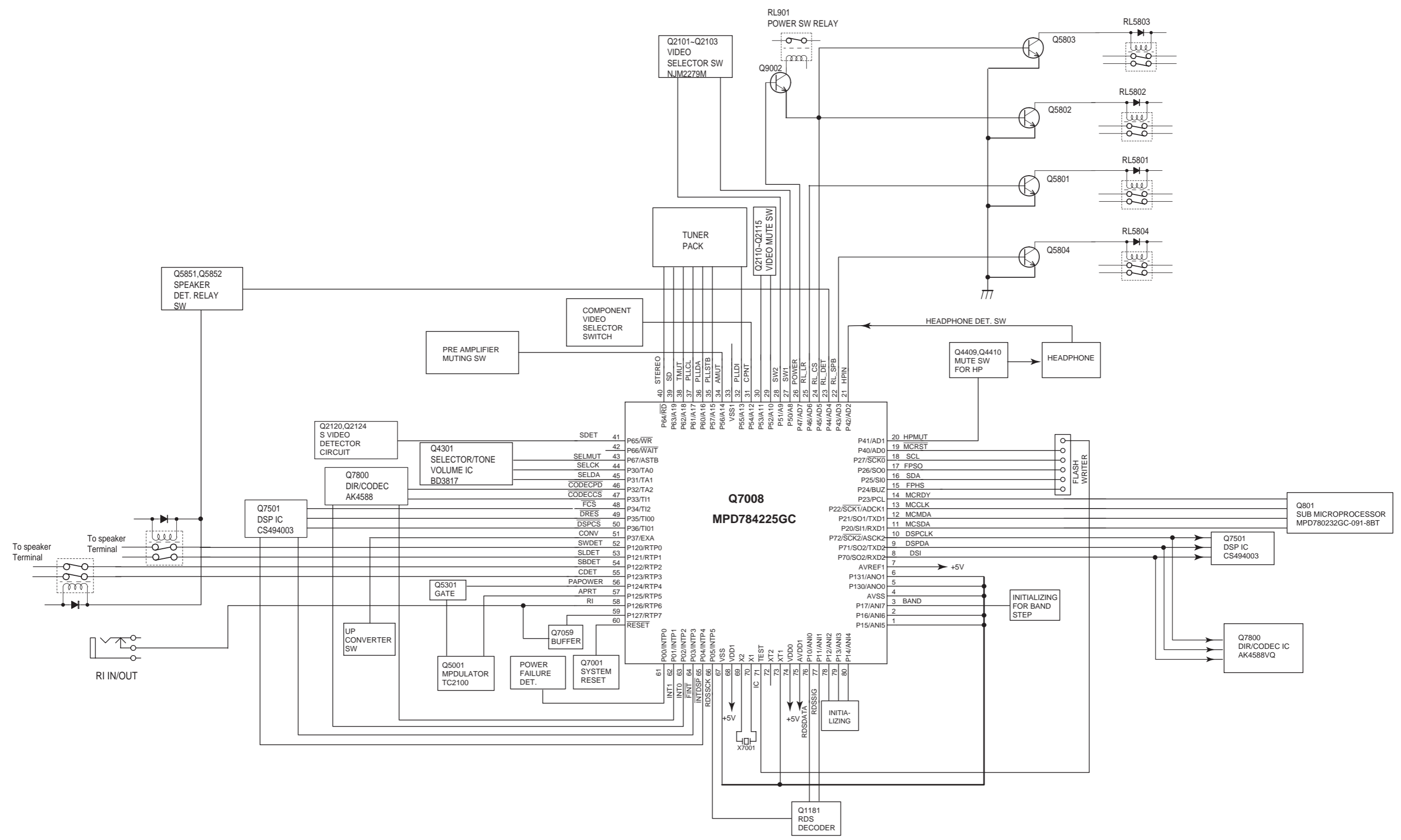

Q801:MPD780232GC-091-8BT(Sub-micro processor)

No.	Symbol	I/O	Description
1	5V	I	Positive power supply (+5V)
2	GND	I	Ground pin
3	CLOCK	I	Oscillator connection pin
4	CLOCK	O	Oscillator connection pin
5	FARIC	I	Not used.
6	~RESET	I	System reset pin
7	SUBCL	I	Transfer clock input pin from main micro processor
8	SUBSI	I	Transfer data input pin from main micro processor
9	SUBSO	O	Data input pin to main micro processor
10	SUBREQ	O	Transfer data ready input pin from main micro processor
11	VOLA	I	Pulse signal input pin from rotary encoder
12	VOLB	I	Pulse signal input pin from rotary encoder
13	STLED	I	STANDBY LED control pin
14	LED1	O	INPUT UP LED control pin
15	~IRIN	I	Not used.
16	LED2	I	LISTENNING MODE LED control pin
17	LED3	O	INPUT DOWN LED control pin
18	AVSS	I	Power supply pin for A/D converter
19	K3	I	Key input pin 3
20	K2	I	Key input pin 2
21	K1	I	Key input pin 1
22	K0	I	Key input pin 0
23	VSS	I	Ground pin
24	AVDD	I	Power supply pin for A/D converter
25	VDD	I	Positive power supply (+5V)
26	NC	---	Not used.
27	NC	---	Not used.
28	P35	O	Segment output pin P35
29	P34	O	Segment output pin P34
30	P33	O	Segment output pin P33
31	P32	O	Segment output pin P32
32	P31	O	Segment output pin P31
33	P30	O	Segment output pin P30
34	P29	O	Segment output pin P29
35	P28	O	Segment output pin P28
36	P27	O	Segment output pin P27
37	P26	O	Segment output pin P26
38	P25	O	Segment output pin P25
39	P24	O	Segment output pin P24
40	P23	O	Segment output pin P23

No.	Symbol	I/O	Description
41	P22	O	Segment output pin P22
42	P21	O	Segment output pin P21
43	P20	O	Segment output pin P20
44	P19	O	Segment output pin P19
45	P18	O	Segment output pin P18
46	P17	O	Segment output pin P17
47	P16	O	Segment output pin P16
48	P15	O	Segment output pin P15
49	P14	O	Segment output pin P14
50	P13	O	Segment output pin P13
51	P12	O	Segment output pin P12
52	P11	O	Segment output pin P11
53	P10	O	Segment output pin P10
54	P9	O	Segment output pin P9
55	P8	O	Segment output pin P8
56	P7	O	Segment output pin P7
57	P6	O	Segment output pin P6
58	P5	O	Segment output pin P5
59	VDD2	I	Positive power supply (+5V)
60	VDISP	I	Negative power supply
61	P4	O	Segment output pin P4
62	P3	O	Segment output pin P3
63	P2	O	Segment output pin P2
64	P1	O	Segment output pin P1
65	P36	O	Segment output pin P36
66	NC	O	Not used.
67	14G	O	Grid output pin 14G
68	13G	O	Grid output pin 13G
69	12G	O	Grid output pin 12G
70	11G	O	Grid output pin 11G
71	10G	O	Grid output pin 10G
72	9G	O	Grid output pin 9G
73	8G	O	Grid output pin 8G
74	7G	O	Grid output pin 7G
75	6G	O	Grid output pin 6G
76	5G	O	Grid output pin 5G
77	4G	O	Grid output pin 4G
78	3G	O	Grid output pin 3G
79	2G	O	Grid output pin 2G
80	1G	O	Grid output pin 1G

Q7008:MPD78F4225GC (Main microprocessor)

No.	Symbol	Signal	I/O	Act.	Description	No.	Symbol	Signal	I/O	Act.	Description
1	P15/ANI5		I		No connection	41	P65/-WR		I		S video detection input pin
2	P16/ANI6		I		No connection	42	P66/-WAIT		I		Not used
3	P17/ANI7	BAND	I	A/D	Tuner frequency setting pin	43	P67/ASTB	SELMUT	O	H	Muting control output pin for Selector, Volume, and Tone IC BD3817
4	AVss				Connect to Vss 0.	44	P30/TO0	SELCLK	O	CLK	Serial Clock output pin for Selector, Volume and Tone IC BD3817
5	P130/ANO0		I		No connection	45	P31/TO1	SELSDO	O	H	Serial Data output pin for Selector, Volume, Tone IC BD3817.
6	P131/ANO1		I		No connection	46	P32/TO2	-DIRRST	O	L	Reset output pin for DIR and CODEC IC AK4588.
7	AVref1				Connect to Vss 0.	47	P33/TI1	-DIRCS	O	L	Chip Select output pin for DIR/CODEC IC AK4588.
8	P70/SI2/RxD2	DSPSDI	I	H	DSP CS49400, DIR/CODEC AK4588 and Serial Data input pin	48	P34/TI2	-DSPFCS	O	L	Chip Select output pin for DSP IC CS49400
9	P71/SO2/TxD2	DSPSDO	O	H	DSP CS49400, DIR/CODEC AK4588 and Serial output pin	49	P35/TI00	-DSPRST	O	L	Reset output pin for DSP IC CS49400
10	P72/-SCK2/ASCK2	DSPCLK	O	CLK	DSP CS49400, DIR/CODEC AK4588 and Serial Clock output pin	50	P36/TI01	-DSPCS	O	L	Chip Select output pin for DSP IC CS49400
11	P20/SI1/RxD1	MCSUP	I	H	Transfer Serial Data input from sub-microprocessor	51	P37/EXA	CONV	O	H	Up Converter switch output pin
12	P21/SO1/TxD1	MCSDN	O	H	Transfer Serial Data output to sub-microprocessor	52	P120/RTP0	SWDET	I	H	Subwoofer channel detection input pin
13	P22/-SCK1/ASCK1	MCCLK	O	CLK	Transfer Serial Clock output and Flash Serial Clock output pin	53	P121/RTP1	SLDET	I	H	Surround left channel detection input pin
14	P23/PCL	MCRDY	I	H	Transfer Sub-microprocessor Data Ready detection pin	54	P122/RTP2	SBDDET	I	H	Surround back channel detection input pin
15	P24/BUZ	FPHS	O		Flash Hand Shake pin	55	P123/RTP3	CDET	I	H	Center channel detection input pin
16	P25/SI0	I2CDO/FPSCI	O	H	Control I2C bus Data and Flash Serial Data input pin	56	P124/RTP4	PAPOWER	O	H	Voltage control output pin for power source of power amplifier
17	P26/SO0	FPSSO	O		Flash Serial Data output pin	57	P125/RTP5	APRT	I	H	Protection circuit detection input pin
18	P27/-SCK0	I2CCLK/FPCLK	O	CLK	Control I2C bus clock and Flash Serial Clock output pin	58	P126/RTP6	SYSIN	I	H	System code input pin
19	P40/AD0	-MCRST	O	L	Reset output pin to sub-microprocessor	59	P127/RTP7	SYSOUT	O	L	System code output pin
20	P41/AD1	HPMUT	O	H	Headphone Muting control output pin	60	-RESET		I	L	Reset input pin
21	P42/AD2	HPIN	I	H	Headphone connection detection input pin	61	P00/INTP0	-POFF	I	L	Power failure detection input pin
22	P43/AD3	SPBRL	O	H	Speaker B Relay control output pin	62	P01/INTP1	DIRINT1	I	H	DIR/CODEC AK4588 Interrupt input pin
23	P44/AD4	DETRL	O	H	Speaker detection Relay control output pin	63	P02/INTP2	DIRINT0	I	H	DIR/CODEC AK4588 Interrupt input pin
24	P45/AD5	SPACSRL	O	H	Center and Surround Relay control output pin for Speaker A	64	P03/INTP3	-FINTREQ	I	L	DSP CS49400 Interrupt Request input pin
25	P46/AD6	SPAFRL	O	H	Front Relay control output pin for Speaker A	65	P04/INTP4	-INTREQ	I	L	DSP CS49400 Interrupt Request input pin
26	P47/AD7	POWRL	O	H	Relay control output pin for Power source	66	P05/INTP5	-RDSCLK	I	CLK	RDS Clock input pin
27	P50/A8	SW1	O	H	Video Selector(NJM2595) Control output pin for SW1	67	Vss0				Power supply pin
28	P51/A9	SW2	O	H	Video Selector(NJM2595) Control output pin for SW2	68	Vdd1				Power supply pin
29	P52/A10	-VMUT2	O	L	Video Output pin for muting 2	69	X2	X2			Ceramic oscillator connection pin (12.5MHz)
30	P53/A11	-VMUT1	O	L	Video Output pin for muting 1	70	X1	X1			Ceramic oscillator connection pin (12.5MHz)
31	P54/A12	CMPRL	O	H	Component video output select control output pin	71	TEST	TEST/VPP			Test pin and Vpp pin for flash writer
32	P55/A13	PLLSDI	I	H	PLL Serial Data Input and IF count end detection pin	72	XT2	XT2			Not used.
33	Vss1				Power supply pin	73	XT1	XT1			Not used.
34	P56/A14	AMUT	O	H	Audio Muting control output pin	74	Vdd0				Power supply pin
35	P57/A15	PLLSTB	O	H	PLL Strobe output pin	75	AVdd				Connect to Vdd2.
36	P60/A16	PLLSDO	O	H	PLL Serial Data output pin	76	P10/ANI0	RDSDATA	I	H	RDS Serial Data input pin
37	P61/A17	PLLCLK	O	CLK	PLL Serial Clock output pin	77	P11/ANI1	RDSSIG	I	H	RDS Signal input pin
38	P62/A18	TUMUT	O	H	Tuner Muting output pin	78	P12/ANI2	INIT1	I	A/D	Initializing pin 1
39	P63/A19	-SD	I	L	Broadcast detection input pin	79	P13/ANI3	INIT2	I	A/D	Initializing pin 2
40	P64/-RD	-STEREO	I	L	FM Stereo detection input pin	80	P14/ANI4	INIT3	I	A/D	Initializing pin 3

ADJUSTMENT AND CONFIRMATION PROCEDURES

1. Offset voltage adjustment

Connect the DC voltmeter to speaker terminal.
Adjust the trimming resistors R5121 to R5126 so that the reading of voltmeter becomes 0+/-100mV.

Note: No load and No signal

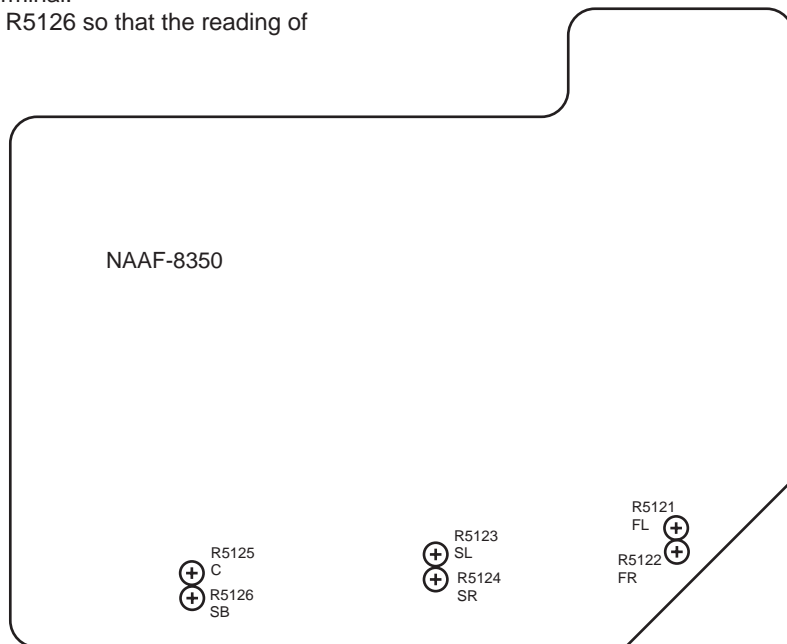

Confirmation of protection circuit

1. Confirmation of speaker relay

Confirm that the speaker relays turn ON approximately 5 seconds after the power switch is turned ON.
Confirm that the speaker relays turn OFF immediately after the power switch is turned OFF.

2. How to enter Test Mode

- To enter a test mode (Test 1 to 4), when the unit is turned on, hold down "LISTENING" button and then press "STANDBY/ON" button.
- After "Test-" lights on FL tube, press "INPUT UP" to set "test-1-00".

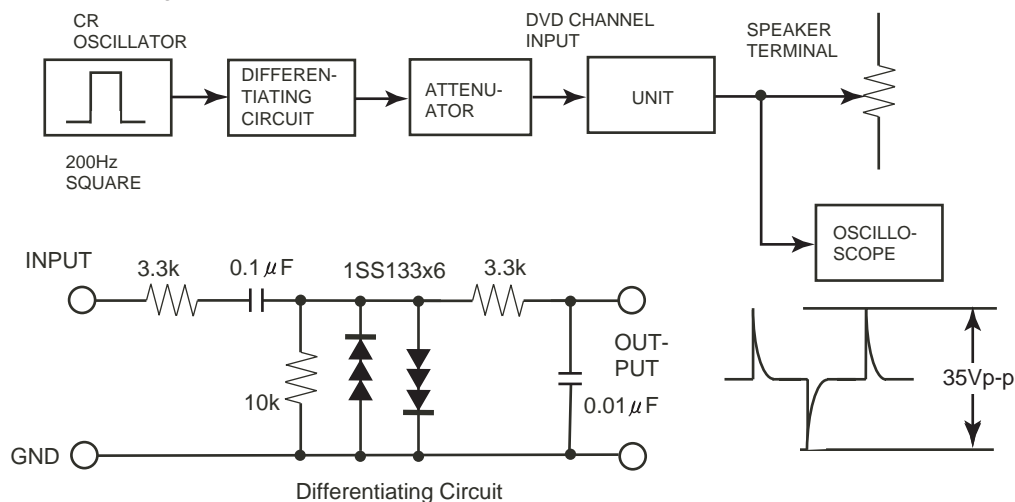

3. Confirmation of Current detection circuit

Set the unit to "Test-1-00".

Connect the differentiating circuit and apply the 200Hz square signal to DVD INPUT terminal of each channel.

Adjust the attenuator or Volume so that the output level becomes 35V p-p.

Confirm that the speaker relay does not turn OFF when a 3.0 ohm load is connected.

Confirm that the speaker relay turns off when a 1.5 ohm load is connected.

Caution: Don't continue more than 3 seconds.

PACKING VIEW

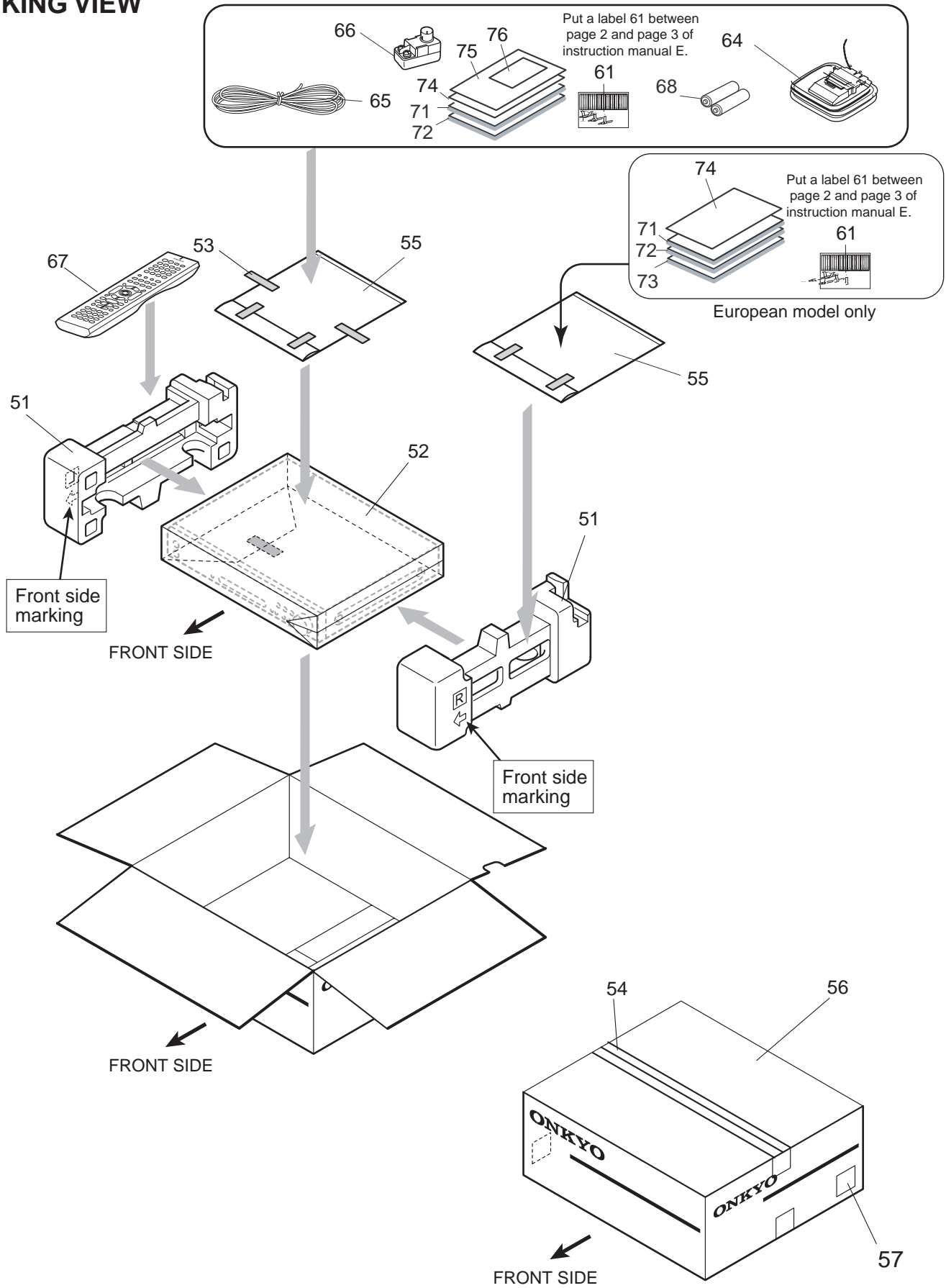

EXPLODED VIEW-PARTS LIST

NOTE: THE COMPONENTS IDENTIFIED BY MARK !
ARE CRITICAL FOR RISK OF FIRE AND
ELECTRIC SHOCK. REPLACE ONLY WITH
PART NUMBER SPECIFIED.

NOTE: <S>:Silver model only <T>:Titanium model only

REF. NO.	PART NO.	DESCRIPTION
1	27100448	Chassis
2	27175319B	Leg
3	28141494	Cushion
4	801612	3TTB+8B(CU),Self-tapping screw
5	27190266	KGLS-12RT,Holder
6	27190524	KGLS-14RT,Holder
7	801612	3TTB+8B(CU),Self-tapping screw
8	27270438	t0.5xφ 8xφ 3.2,Cushion
9	801612	3TTB+8B(CU),Self-tapping screw
11	830440069	4TTC+6C(BC),Self-tapping screw
12	27301394	HL-18-0,Clamp
13	28175310	Isolated plate
14	801612	3TTB+8B(CU),Self-tapping screw
15	28141606	Cushion
17	29110083	16mm,Cloth tape
18	27300750	! Bushing cord
19	27111355	Front bracket <S>
	27111367	Front bracket <T>
21	28198989	Facet, volume
22	801612	3TTB+8B(CU),Self-tapping screw
24	28198906	Facet
25	28192037	Clear plate <S>
	28192047	Clear plate <T>
27	28184898	Top cover
28	838930088	3TTB+8B(UN),Self-tapping screw
29	29363767	Label, cover
31	27123277A	Rear panel
32	838430088	3TTB+8B(BC),Self-tapping screw
35	27212670	Front panel <S>
	27212710	Front panel <T>
37	838430088	3TTB+8B(BC),Self-tapping screw
38	28135245	Badge <S>
	28135290	Badge <T>
41	28326229A	Knob, volume <S>
	28326256	Knob, volume <T>
F9001	252254 or	! 2.5A-T/UL-ST2 or
	252160	! 2.5A-UL/T-237,Fuse
L901	230982	! ATFC-25-15-12Core
P1101	2047152012	NCFC7-152012,Flat cable
P850	260208	BSK-1,Wire tie
P9301	253332HIT or	! AS-UC-2 or
	253333VOL	! AS-UC-2,Power supply cord
T9001	2301761	! NPT-1500D,Power transformer
U1	1A982538-1H	NADG-8338-1H,Main circuit PC board ass'y
U3	1A982540-1H	NAETC-8340-1H,Connector PC board ass'y
U4	1A982541-1H	NAETC-8341-1H,Headphone terminal PC board
U5	1A982542-1H	NAPS-8342-1H,Power supply circuit PC board ass'y
U6	1A982544-1H	NAVD-8344-1H,Component video PC board ass'y
U8	1A982543-1H	NADIS-8343-1H,Display circuit PC board ass'y
U9	1A982548-1H	NASW-8348-1H,Standby switch PC board ass'y
U11	1A982550-1H	NAAF-8350-1H,Digital amplifier PC board ass'y
U13	1A982552-1H	NAETC-8352-1H,Speaker terminal PC board ass'y
U21	240134A	TFCE1U114B,Tuner unit

PACKING VIEW-PARTS LIST

REF. NO.	PART NO.	DESCRIPTION
51	29092209	Pad
52	29100141A	700*600,Polybag
53	29110149	Tape, cellophane
54	29110148	W48,Tape PP
55	29100097-1A	350*250,Polybag
56	29054221	Carton box <S>
	29054281	Carton box <T>
57	29363766	Label UPC <S>
	29363994	Label UPC <T>
61	29363059A	Label, speaker cable
64	232201	NMA-3064,AM loop antenna
65	292191	FM antenna
67	24140577	RC-577S, Remote controller
68	3010054	R6/AA(UM-3),Battery
71	29343748	Instruction manual
72	29343749	Instruction manual, digest
74	29095982	Instruction sheet
75	29355483	Instruction sheet U10
76	29365090B	Warranty card

PRINTED CIRCUIT BOARD-PARTS LIST

NOTE: THE COMPONENTS IDENTIFIED BY MARK !
ARE CRITICAL FOR RISK OF FIRE AND
ELECTRIC SHOCK. REPLACE ONLY WITH
PART NUMBER SPECIFIED.

NOTE: <D>:120V model only <T>:Asian model for 220V
<P>:European model only <O>: Except 120V model
<Q>:Hongkong model only <A>:Australian model only

MAIN CIRCUIT PC BOARD (NADG-8338-1B/1D/1F/1H/1I)
CONNECTOR PC BOARD (NAETC-8340-1B/1D/1F/1H/1I)
HEADPHONE TERMINAL PC BOARD (NAETC-8341-1B/1D/1F/1H/1I)

CIRCUIT NO.	PART NO.	DESCRIPTION
	ICs	
Q1181	22242120R2	BU1924FS <P>
Q2001	22241858R2	MM1093NF <D>
Q2005	22241850R2	TC90A69F <D>
Q2051	22241443R2	TK15420M <D>
Q2101~ Q2103	22241368R2	NJM2279M
Q2106	22241849R2	MM1512 <D>
Q4301	22242117R3	BD3817KS
Q4321	222780073R2	78L07(SMT)
Q4322	222790073R2	79L07(SMT)
Q4421~Q4425,Q4481	22241383R2	NJM4565M-D
Q4801~Q4804	22241383R2	NJM4565M-D
Q7002	22274541ER2TO	TC74VHC541FT
Q7003	222740077R2TO	TC74HCT7007AF
Q7004	22241778R2	BA33C25FP
Q7008	222W0016R3	MPD78F4225GC
Q7501	22242039R3	CS494003CQZ
Q7502	22242119R3	MX29LV040
Q7503	22240935R2	TC7WU04FU
Q7800	22242118R3	AK4588VQ
Q9602,Q9609	222780125	78M12HF
Q9603	222790125	79M12HF
Q9604	222780055	78M05HF
Q9605	222790055	79M05FA
Q9606	22278005DNE	MPC2905HF
Q9607	222780093JRCT	78L09(NJM78L09A)
Q9608	222780565	78M56
	Transistors	
Q2002~Q2004	2213145R2 or 2216175R2	2SC2712-GR or KTC3875-GR <D>
Q2071,Q2120	2214375R2 or 2216185R2	2SA1162-GR or KTA1504-GR <D>
Q2110~Q2115	2215510R2	RN1443 <D>
Q2116,Q2117	2214550R2 or	RN2404 or
Q2124	2216220R2	KRA102S <D>
Q4401~Q4412	2215410R2	RN1441
Q4501,Q4502	2214530R2 or 2216220R2	RN2402 or KRA102S
Q7001	2214490R2 or 2216210R2	RN1404 or KRC104S
Q7011,Q7012	2214490R2 or 2216210R2	RN1404 or KRC104S <D>
Q7059	2214540R2 or 2216230R2	RN2403 or KRA103S
Q9501	2211455	2SA1015-GR
	Diodes	
D2102,D2103	223269R2 or 223234R2	1SS355 or 1SS352 <D>
D7001,D7002	223269R2 or	1SS355 or
D7004,D7058	223234R2	1SS352
D7059	224660514R2 or	HZU5.1B or
D7204~D7206,D9611	224550510R2	UDZS5.1B

CIRCUIT NO.	PART NO.	DESCRIPTION
	Diodes	
D7401~D7404	223269R2 or 223234R2	1SS355 or 1SS352
D9502~D9505	22380260 or 22380035	RL1N4003 or GP104003E
D9507	224663604R2 or 224553600R2	HZU36B or UDZS36B
D9513	22380341F	D2SB80A
	Oscillators	
X1181	3010203	AF6146CG <P>
X2001	3010369	HC-49/U033.579545M <D>
X7001	3010361R2	CSTCE12M5G52-R0
X7581	3010324R2	CSTCV12.2MTJ0C4
	Coils	
L1181	231237K220R2 or 233533K220R2	NCH-1477 or NCH-1587-220K <P>
L2001	231237K330R2	NCH-1478 <D>
L2002,L2003,L2004	231237K220R2 or 233533K220R2	NCH-1477 or NCH-1587-220K <D>
L2005,L2006,L2008	231237K101R2 or 233533K101R2	NCH-1481 or NCH-1587-101K <D>
L2007,L2009	230958R1	BK1608LM182-T
L2010	231237K470R2	NCH-1479
L4601,L4602,L4603	231237M015R2	NCH-1470
L7001	231237K220R2 or 233533K220R2	NCH-1477 or NCH-1587-220K
L7002	231237M022R2	NCH-1471
L7051,L7052,L7551	231237M022R2 or 233533K022R2	NCH-1471 or NCH-1587-022K
L7583,L7801	230958R1	BK1608LM182-T
L7501,L7502	231237K220R2	NCH-1477
L7503,L7803		
L7581,L7582,L7802		
L7800		
	Capacitors	
C1101,C1103	394780337 or 394680337	CE04W50V3.3M(SC) or CE04W50V-3.3M(VR),Elect.
C1104,C1106	342101014R1	CC725CH1H-101J1,Ceramic
C1181	394780227 or 394680227	CE04W50V2.2M(SC) or CE04W50V-2.2M(VR),Elect. <P>
C1182	332101035R1	CK725B1H-103K1,Ceramic <P>
C1183	342105614R1	CC725CH1H-561J1,Ceramic <P>
C1184	394744707 or 394644707	CE04W16V47M(SC) or CE04W16V-47M(VR),Elect. <P>
C1185	332161040R1	CK725F1E-104Z1,Ceramic <P>
C1186,C1187	342103304R1	CC725CH1H-330J1,Ceramic <P>
C2001,C2027,C2030	332161040R1	CK725F1E-104Z1,Ceramic <D>
C2002,C2021,C2033	394721017 or 394621017	CE04W6.3V100M(SC) or CE04W6.3V-100M(VR),Elect. <D>
C2003	394780227 or 394680227	CE04W50V2.2M(SC) or CE04W50V-2.2M(VR),Elect. <D>
C2005	342105604R1	CC725CH1H-560J1,Ceramic <D>
C2006,C2008,C2024	332151030R1	CK725F1H-103Z1,Ceramic <D>
C2007	394780477 or 394680477	CE04W50V4.7M(SC) or CE04W50V-4.7M(VR),Elect. <D>
C2009	342103914R1	CC725CH1H-391J1,Ceramic <D>
C2010,C2011	342115614R1	CC725CH1E-561J1,Ceramic <D>
C2012,C2032	394784797 or 394684797	CE04W50V0.47M(SC) or CE04W50V-0.47M(VR),Elect. <D>
C2013,C2017,C2018	342101204R1	CC725CH1H-120J1,Ceramic <D>
C2014,C2019,C2020	342102204R1	CC725CH1H-120J1,Ceramic <D>
C2015,C2016	394744707 or 394644707	CE04W16V47M(SC) or CE04W16V-47M(VR),Elect.
C2022	375521044	MMT50V-104J,Plastic <D>
C2023	374726814	ECQ-B50V-681J,Plastic <D>

CIRCUIT NO.	PART NO.	DESCRIPTION
C2025,C2026,C2028 C2029,C2037,C2038	332151030R1 332151030R1	CK725F1H-103Z1,Ceramic <D> CK725F1H-103Z1,Ceramic <D>
Capacitors		
C2031,C2043,C2044 C2034,C2041,C2042	332161040R1 394721017 or 394621017	CK725F1E-104Z1,Ceramic <D> CE04W6.3V100M(SC) or CE04W6.3V-100M(VR),Elect. <D>
C2035,C2036,C2071	394744707 or 394644707	CE04W16V47M(SC) or CE04W16V-47M(VR),Elect. <D>
C2039,C2040,C2160 C2108,C2113	332151030R1 332101025R1	CK725F1H-103Z1,Ceramic <D> CK725B1H-102K1,Ceramic
C2111,C2115,C2117 C2119,C2120,C2121 C2122,C2123,C2124 C2127,C2128,C2129 C2134,C2135,C2136 C2137,C2138,C2139	342104704R1 394741007 or 394641007 332161040R1 332161040R1 394721017 or 394621017	CC725CH1H-470J1,Ceramic CE04W16V10M(SC) or CE04W16V-10M(VR),Elect. CK725F1E-104Z1,Ceramic CK725F1E-104Z1,Ceramic CE04W6.3V100M(SC) or CE04W6.3V-100M(VR),Elect.
C2140,C2141,C2142 C2149,C2150,C2151	342104704R1 394721017 or 394621017	CC725CH1H-470J1,Ceramic <D> CE04W6.3V100M(SC) or CE04W6.3V-100M(VR),Elect.
C2152,C2153,C2154 C2155	332161040R1 394742207 or 394642207	CK725F1E-104Z1,Ceramic CE04W16V22M(SC) or CE04W16V-22M(VR),Elect. <D>
C2156,C2157	394721017 or 394621017	CE04W6.3V100M(SC) or CE04W6.3V-100M(VR),Elect. <D>
C2158,C2179 C2159	332161040R1 394780107 or 394680107	CK725F1E-104Z1,Ceramic <D> CE04W50V1.0M(SC) or CE04W50V-1M(VR),Elect. <D>
C2161,C2162,C2163 C2187,C2189 C2194,C2196	342104704R1 332161040R1 394724717 or 394624717	CC725CH1H-470J1,Ceramic <O> CK725F1E-104Z1,Ceramic <D> CE04W6.3V470M(SC) or CE04W6.3V-470M(VR),Elect. <D>
C4300,C4301 C4300,C4301 C4302,C4303,C4304	374721015 374724714 342101014R1 342104714R1	ECQ-B50V-101K,Plastic <D> ECQ-B50V-471J,Plastic <O> CC725CH1H-101J1,Ceramic <D> CC725CH1H-471J1,Ceramic <O>
C4305,C4306,C4307	342101014R1 342104714R1	CC725CH1H-101J1,Ceramic <D> CC725CH1H-471J1,Ceramic <O>
C4308,C4309,C4310	342101014R1 342104714R1	CC725CH1H-101J1,Ceramic <D> CC725CH1H-471J1,Ceramic <O>
C4311,C4312,C4313	342101014R1 342104714R1	CC725CH1H-101J1,Ceramic <D> CC725CH1H-471J1,Ceramic <O>
C4314,C4315	342101014R1 342104714R1	CC725CH1H-101J1,Ceramic <D> CC725CH1H-471J1,Ceramic <O>
C4316,C4317,C4318 C4323,C4345,C4346 C4341,C4342	332101025R1 393341007 394741007 or 394641007	CK725B1H-102K1,Ceramic CE04W16V-10M(VX),Elect. CE04W16V10M(SC) or CE04W16V-10M(VR),Elect.
C4343,C4344	394742217 or 394642217	CE04W16V220M(SC) or CE04W16V-220M(VR),Elect.
C4347,C4348 C4350,C4604,C4605 C4363,C4364,C4368 C4370,C4371 C4372,C4373,C4374 C4375,C7802 C4401,C4402,C4403 C4404,C4405,C4406 C4407,C4408,C4409 C4410,C4411,C4412 C4419 C4420 C4421,C4483,C4484	393341007 332161040R1 393341007 374724724 374721044 374721044 393344707 393344707 393344707 393344707 374722224 393344707 342103304R1	CE04W16V-10M(VX),Elect. CK725F1E-104Z1,Ceramic CE04W16V-10M(VX),Elect. ECQ-B50V-472J,Plastic ECQ-V50V-104J,Plastic ECQ-V50V-104J,Plastic CE04W16V-47M(VX),Elect. CE04W16V-47M(VX),Elect. CE04W16V-47M(VX),Elect. CE04W16V-47M(VX),Elect. ECQ-B50V-222J,Plastic CE04W16V-47M(VX),Elect. CC725CH1H-330J1,Ceramic

CIRCUIT NO.	PART NO.	DESCRIPTION
C4422	342102214R1	CC725CH1H-221J1,Ceramic
C4433,C4434	393321017	CE04W6.3V-100M(VX),Elect.
C4435,C4436,C7520	342101014R1	CC725CH1H-101J1,Ceramic
CIRCUIT NO.	PART NO.	DESCRIPTION
	Capacitors	
C4437,C4438,C4439	393341007	CE04W16V-10M(VX),Elect.
C4440,C4481,C4482	393341007	CE04W16V-10M(VX),Elect.
C4450,C4451	394642217	CE04W16V-220M(VR),Elect.
C4501,C4503	332132245R1	CK725B1A-224K1,Ceramic
C4502,C4504	337394745R1	CK732B1C-474K,Ceramic
C4601,C4602	342101024R1	CC725CH1H-102J1,Ceramic
C4603	332101025R1	CK725B1H-102K1,Ceramic
C7001	3000121,	SCDA5R5104A,
	3000078 or	DX-5R5L104 or
	3000120	FMC0H104Z,Super
C7002,C7005	394721017 or	CE04W6.3V100M(SC) or
	394621017	CE04W6.3V-100M(VR),Elect.
C7003,C7007,C7009	332161040R1	CK725F1E-104Z1,Ceramic
C7004,C7513	394780107 or	CE04W50V1.0M(SC) or
	394680107	CE04W50V-1M(VR),Elect.
C7010,C7013,C7014	332161040R1	CK725F1E-104Z1,Ceramic
C7011,C7012,C7501	394744707 or	CE04W16V47M(SC) or
	394644707	CE04W16V-47M(VR),Elect.
C7015,C7503	394724717 or	CE04W6.3V470M(SC) or
	394624717	CE04W6.3V-470M(VR),Elect.
C7401,C7402,C7860	393341007	CE04W16V-10M(VX),Elect.
C7502,C7507,C7508	332161040R1	CK725F1E-104Z1,Ceramic
C7504	395640227R2	CS772SB1C-2.2M,tantal
C7505	347341224R2	CC732CH1H-122J,Ceramic
C7506	342106804R1	CC725CH1H-680J1,Ceramic
C7509,C7510,C7511	332161040R1	CK725F1E-104Z1,Ceramic
C7512,C7514,C7515	332161040R1	CK725F1E-104Z1,Ceramic
C7516,C7517,C7518	332161040R1	CK725F1E-104Z1,Ceramic
C7519,C7552,C7568	332161040R1	CK725F1E-104Z1,Ceramic
C7551	394722217 or	CE04W6.3V220M(SC) or
	394622217	CE04W6.3V-220M(VR),Elect.
C7581,C7806,C7811	332161040R1	CK725F1E-104Z1,Ceramic
C7800,C7814,C7817	342103304R1	CC725CH1H-330J1,Ceramic
C7804	393342207	CE04W16V-22M(VX),Elect.
C7807,C7816,C9612	394721017 or	CE04W6.3V100M(SC) or
	394621017	CE04W6.3V-100M(VR),Elect.
C7809,C7813	394724717 or	CE04W6.3V470M(SC) or
	394624717	CE04W6.3V-470M(VR),Elect.
C7820,C7821,C7822	373028214R2	ECHU50V-821J,Plastic
C7823,C7850,C7851	373028214R2	ECHU50V-821J,Plastic
C7824	373048224R2	ECHU16V-822J,Plastic
C7829,C7831,C7833	373021224R2	ECHU50V-122J,Plastic
C7830,C7832,C7834	373021014R2	ECHU50V-101J,Plastic
C7835,C7838	373021014R2	ECHU50V-101J,Plastic
C7836,C7854,C7855	373021224R2	ECHU50V-122J,Plastic
C7837	373041234R2	ECHU16V-123J,Plastic
C7852,C7853	373021014R2	ECHU50V-101J,Plastic
C7861,C7862,C7863	393341007	CE04W16V-10M(VX),Elect.
C7864,C7865,C7866	393344707	CE04W16V-47M(VX),Elect.
C9501,C9502,C9503	374721044	ECQ-V50V-104J,Plastic
C9505	394652227S	CE04W25V-2200M(VR),Elect.
C9506	394661027S	CE04W35V-1000M(VR),Elect.
C9508	394641037S	CE04W16V-10000M(VR),Elect.
C9510	394672217	CE04W63V-220M(VR),Elect.
C9511,C9512	332152230R1	CK725F1H-223Z1,Ceramic
C9603,C9607	374721044	ECQ-V50V-104J,Plastic
C9604,C9606,C9608	394741007 or	CE04W16V10M(SC) or
C9610,C9616,C9618	394641007	CE04W16V-10M(VR),Elect.
C9605,C9609	394780227 or	CE04W50V2.2M(SC) or

C9611,C9615 C9613	394680227 374721044 374721044	CE04W50V-2.2M(VR),Elect. ECQ-V50V-104J,Plastic ECQ-V50V-104J,Plastic <D>
CIRCUIT NO.	PART NO.	DESCRIPTION
	Capacitors	
C9614	394741007 or 394641007	CE04W16V10M(SC) or CE04W16V-10M(VR),Elect. <D>
C9617	394744707 or 394644707	CE04W16V47M(SC) or CE04W16V-47M(VR),Elect.
	Resistors	
R1102,R1103	435032234R1	RN72K1J-223JE,Carbon
R1104	435031044R1	RN72K1J-104JE,Carbon
R1138,R1139	435032234R1	RN72K1J-223JE,Carbon
R1181,R1182	435031024R1	RN72K1J-102JE,Carbon <P>
R1183,R1184	435031024R1	RN72K1J-102JE,Carbon <P>
R1185,R1186,R1187	435034734R1	RN72K1J-473JE,Carbon <D/T/A/Q>
R2001,R2002	435031034R1	RN72K1J-103JE,Carbon <D>
R2003	435031534R1	RN72K1J-153JE,Carbon <D>
R2004	435031054R1	RN72K1J-105JE,Carbon <D>
R2005,R2006	435033914R1	RN72K1J-391JE,Carbon <D>
R2007,R2010,R2013	435038214R1	RN72K1J-821JE,Carbon <D>
R2008	435033324R1	RN72K1J-332JE,Carbon <D>
R2009	435031524R1	RN72K1J-152JE,Carbon <D>
R2011,R2012,R2075	435031224R1	RN72K1J-122JE,Carbon <D>
R2014,R2015,R2016	435038214R1	RN72K1J-821JE,Carbon <D>
R2017,R2059,R2071	435033314R1	RN72K1J-331JE,Carbon <D>
R2018,R2019,R2051	435031014R1	RN72K1J-101JE,Carbon <D>
R2053,R2063	435031034R1	RN72K1J-103JE,Carbon <D>
R2054,R2064,R2074	435032724R1	RN72K1J-272JE,Carbon <D>
R2056,R2066	435031824R1	RN72K1J-182JE,Carbon <D>
R2057,R2067	435032214R1	RN72K1J-221JE,Carbon <D>
R2061,R2100,R2101	435031014R1	RN72K1J-101JE,Carbon <D>
R2073,R2177	435032224R1	RN72K1J-222JE,Carbon <D>
R2076	435034714R1	RN72K1J-471JE,Carbon <D>
R2102,R2103	435031044R1	RN72K1J-104JE,Carbon <D>
R2104,R2105,R2106	435037504R1	RN72K1J-750JE,Carbon
R2108,R2115,R2121	435031034R1	RN72K1J-103JE,Carbon <D>
R2111,R2112,R2113	435037504R1	RN72K1J-750JE,Carbon
R2117,R2118,R2119	435037504R1	RN72K1J-750JE,Carbon
R2128,R2129,R2130	435037504R1	RN72K1J-750JE,Carbon
R2132,R2138,R2139	435038204R1	RN72K1J-820JE,Carbon <D>
R2134,R2135,R2136	435037504R1	RN72K1J-750JE,Carbon <D>
R2145,R2146,R2147	435031024R1	RN72K1J-102JE,Carbon <D>
R2148,R2170,R2193	435031024R1	RN72K1J-102JE,Carbon <D>
R2150,R2151,R2152	435030004R1	RN72K1J-000JE,Carbon <D>
R2153,R2154,R2155	435030004R1	RN72K1J-000JE,Carbon <D>
R2161,R2162,R2163	435037504R1	RN72K1J-750JE,Carbon <O>
R2173	435033334R1	RN72K1J-333JE,Carbon <D>
R2176	435036804R1	RN72K1J-680JE,Carbon <P>
R2189	435031034R1	RN72K1J-103JE,Carbon
R2198	435033314R1	RN72K1J-331JE,Carbon <D>
R4300,R4301,R4302	435033314R1	RN72K1J-331JE,Carbon
R4303,R4304,R4305	435033314R1	RN72K1J-331JE,Carbon
R4306,R4307,R4308	435033314R1	RN72K1J-331JE,Carbon
R4309,R4310,R4311	435033314R1	RN72K1J-331JE,Carbon
R4312,R4313,R4314	435033314R1	RN72K1J-331JE,Carbon
R4315	435033314R1	RN72K1J-331JE,Carbon
R4322,R4323,R4324	435034734R1	RN72K1J-473JE,Carbon
R4325,R4326,R4327	435034734R1	RN72K1J-473JE,Carbon
R4328,R4329,R4330	435034734R1	RN72K1J-473JE,Carbon
R4331,R4332,R4333	435034734R1	RN72K1J-473JE,Carbon
R4334,R4335,R4336	435034734R1	RN72K1J-473JE,Carbon
R4337,R4432	435034734R1	RN72K1J-473JE,Carbon

CIRCUIT NO.	PART NO.	DESCRIPTION
R4353,R4354,R4431	435034724R1	RN72K1J-472JE,Carbon
R4401,R4402,R4403	435032244R1	RN72K1J-224JE,Carbon
R4404,R4405,R4406	435032244R1	RN72K1J-224JE,Carbon
R4407,R4408,R4409	435034714R1	RN72K1J-471JE,Carbon
R4410,R4411,R4412	435034714R1	RN72K1J-471JE,Carbon
Resistors		
R4413,R4414,R4415	435032234R1	RN72K1J-223JE,Carbon
R4416,R4417,R4418	435032234R1	RN72K1J-223JE,Carbon
R4419,R4420,R4421	435032234R1	RN72K1J-223JE,Carbon
R4422,R4423,R4424	435032234R1	RN72K1J-223JE,Carbon
R4425,R4427,R7000	435031014R1	RN72K1J-101JE,Carbon
R4426,R4429	435032234R1	RN72K1J-223JE,Carbon
R4428	435032714R1	RN72K1J-271JE,Carbon
R4430	435032734R1	RN72K1J-273JE,Carbon
R4433	435031024R1	RN72K1J-102JE,Carbon
R4441,R4442,R4449	435032244R1	RN72K1J-224JE,Carbon
R4443,R4444	435034704R1	RN72K1J-470JE,Carbon
R4445,R4446	435031034R1	RN72K1J-103JE,Carbon
R4447,R4448	435035624R1	RN72K1J-562JE,Carbon
R4450,R4451,R4452	435032244R1	RN72K1J-224JE,Carbon
R4453,R4454	435033324R1	RN72K1J-332JE,Carbon
R4461,R4462	4500183	RNU1/4WJ-22,Metal
R4481,R4482	435034744R1	RN72K1J-474JE,Carbon
R4483,R4484	435031034R1	RN72K1J-103JE,Carbon
R4485,R4486	435031034R1	RN72K1J-103JE,Carbon
R4489,R4490	435034714R1	RN72K1J-471JE,Carbon
R4491,R4492	435032224R1	RN72K1J-222JE,Carbon
R4493,R4494	435031034R1	RN72K1J-103JE,Carbon
R4501,R4502	435031044R1	RN72K1J-104JE,Carbon
R4601,R4602	435034704R1	RN72K1J-470JE,Carbon
R7003	435031034R1	RN72K1J-103JE,Carbon <T/A/Q>
	435033334R1	RN72K1J-333JE,Carbon <P>
	435030004R1	RN72K1J-000JE,Carbon <D>
R7003,R7078	435032214R1	RN72K1J-221JE,Carbon
R7008,R7009,R7010	435038204R1	RN72K1J-820JE,Carbon
R7011,R7012,R7013	435038204R1	RN72K1J-820JE,Carbon
R7014,R7015,R7016	435038204R1	RN72K1J-820JE,Carbon
R7017,R7018	435038204R1	RN72K1J-820JE,Carbon
R7019,R7020,R7022	435032214R1	RN72K1J-221JE,Carbon
R7021,R7038,R7039	435032224R1	RN72K1J-222JE,Carbon
R7023,R7024,R7025	435032214R1	RN72K1J-221JE,Carbon
R7026,R7027,R7028	435032214R1	RN72K1J-221JE,Carbon
R7029,R7030,R7031	435032214R1	RN72K1J-221JE,Carbon
R7032,R7035,R7036	435032214R1	RN72K1J-221JE,Carbon
R7034,R7209	435034714R1	RN72K1J-471JE,Carbon
R7037,R7040,R7041	435032214R1	RN72K1J-221JE,Carbon
R7043,R7080	435031034R1	RN72K1J-103JE,Carbon
R7044,R7045,R7046	435031024R1	RN72K1J-102JE,Carbon
R7047,R7048,R7051	435032214R1	RN72K1J-221JE,Carbon
R7049,R7050,R7062	435031024R1	RN72K1J-102JE,Carbon
R7052,R7053,R7054	435032214R1	RN72K1J-221JE,Carbon
R7055,R7056,R7057	435032214R1	RN72K1J-221JE,Carbon
R7058,R7060,R7400	435034734R1	RN72K1J-473JE,Carbon
R7059	435032244R1	RN72K1J-224JE,Carbon
R7063,R7064,R7065	435031024R1	RN72K1J-102JE,Carbon
R7066,R7076,R7077	435031024R1	RN72K1J-102JE,Carbon
R7067,R7068,R7069	435032214R1	RN72K1J-221JE,Carbon
R7070,R7072,R7081	435032214R1	RN72K1J-221JE,Carbon
R7071,R7834,R7837	435034724R1	RN72K1J-472JE,Carbon
R7078	435031034R1	RN72K1J-103JE,Carbon <O>
R7079	435030004R1	RN72K1J-000JE,Carbon <P>
	435031034R1	RN72K1J-103JE,Carbon <D/T/A/Q>
R7082,R7083,R7084	435032214R1	RN72K1J-221JE,Carbon
R7085,R7504,R7506	435032214R1	RN72K1J-221JE,Carbon

R7103	435031034R1	RN72K1J-103JE,Carbon <T/Q>
	435033334R1	RN72K1J-333JE,Carbon <A>
	435035634R1	RN72K1J-563JE,Carbon <P>
R7114,R7143	435031034R1	RN72K1J-103JE,Carbon
R7120,R7134	435031024R1	RN72K1J-102JE,Carbon
R7121,R7409,R7410	435031044R1	RN72K1J-104JE,Carbon
CIRCUIT NO.	PART NO.	DESCRIPTION
	Resistors	
R7161,R7311,R7312	435030004R1	RN72K1J-000JE,Carbon
R7178	435033334R1	RN72K1J-333JE,Carbon <O>
R7179	435033334R1	RN72K1J-333JE,Carbon <D/T/A/Q>
R7180	435031034R1	RN72K1J-103JE,Carbon
R7201,R7202	435035634R1	RN72K1J-563JE,Carbon
R7203,R7207	435035634R1	RN72K1J-563JE,Carbon
R7313,R7314,R7315	435030004R1	RN72K1J-000JE,Carbon
R7316,R7317,R7318	435030004R1	RN72K1J-000JE,Carbon
R7401,R7402,R7403	435034734R1	RN72K1J-473JE,Carbon
R7404,R7405,R7406	435034734R1	RN72K1J-473JE,Carbon
R7407,R7408	435031534R1	RN72K1J-153JE,Carbon
R7411,R7412,R7800	435035604R1	RN72K1J-560JE,Carbon
R7500,R7812	435033314R1	RN72K1J-331JE,Carbon
R7501	435032724R1	RN72K1J-272JE,Carbon
R7502,R7503,R7508	435033324R1	RN72K1J-332JE,Carbon
R7505,R7507	435031034R1	RN72K1J-103JE,Carbon
R7509,R7511,R7513	435033324R1	RN72K1J-332JE,Carbon
R7510,R7516,R7517	435032214R1	RN72K1J-221JE,Carbon
R7512,R7522	435031034R1	RN72K1J-103JE,Carbon
R7514,R7515,R7519	435033324R1	RN72K1J-332JE,Carbon
R7518,R7546,R7547	435032214R1	RN72K1J-221JE,Carbon
R7520,R7521,R7523	435033324R1	RN72K1J-332JE,Carbon
R7524,R7525,R7526	435034704R1	RN72K1J-470JE,Carbon
R7527,R7528,R7529	435034704R1	RN72K1J-470JE,Carbon
R7530,R7531,R7532	435034704R1	RN72K1J-470JE,Carbon
R7533,R7534,R7535	435034704R1	RN72K1J-470JE,Carbon
R7536,R7537,R7538	435034704R1	RN72K1J-470JE,Carbon
R7539,R7540,R7541	435034704R1	RN72K1J-470JE,Carbon
R7542,R7543	435034704R1	RN72K1J-470JE,Carbon
R7544,R7545	435034704R1	RN72K1J-470JE,Carbon
R7548,R7549,R7551	435032214R1	RN72K1J-221JE,Carbon
R7550	435033324R1	RN72K1J-332JE,Carbon
R7561,R7562	435032204R1	RN72K1J-220JE,Carbon
R7581	435031054R1	RN72K1J-105JE,Carbon
R7801,R7802,R7804	435035604R1	RN72K1J-560JE,Carbon
R7803,R7805	435031024R1	RN72K1J-102JE,Carbon
R7806,R7808	435031024R1	RN72K1J-102JE,Carbon
R7807,R7816,R7817	435035604R1	RN72K1J-560JE,Carbon
R7809	435030474R1	RN72K1J-047JE,Carbon
R7810	435031234R1	RN72K1J-123JE,Carbon
R7813,R7814,R7818	435033314R1	RN72K1J-331JE,Carbon
R7819,R7820,R7821	435035604R1	RN72K1J-560JE,Carbon
R7822,R7823,R7825	435035604R1	RN72K1J-560JE,Carbon
R7824,R7826,R7829	435031024R1	RN72K1J-102JE,Carbon
R7828,R7835,R7836	435032224R1	RN72K1J-222JE,Carbon
R7838,R7841,R7842	435034724R1	RN72K1J-472JE,Carbon
R7839,R7840,R7843	435032224R1	RN72K1J-222JE,Carbon
R7844,R7853,R7854	435032224R1	RN72K1J-222JE,Carbon
R7845,R7852,R7855	435034724R1	RN72K1J-472JE,Carbon
R7863,R7864,R7865	435034724R1	RN72K1J-472JE,Carbon
R7866,R7873,R7875	435034724R1	RN72K1J-472JE,Carbon
R7867,R7868,R7869	435032224R1	RN72K1J-222JE,Carbon
R7870,R7872,R7874	435032224R1	RN72K1J-222JE,Carbon
R9501	453530224	RNU1/2WCJ-2.2,Metal
R9506	443522204	RS1/2WBJ-22,Metal oxide
R9507,R9508	435038224R1	RN72K1J-822JE,Carbon

R9509	435031044R1	RN72K1J-104JE,Carbon
R9602,R9603	452530104F	RNU1/2WCJ-1,Metal
R9604,R9605	452530154F	RNU1/2WCJ-1.5,Metal
R9606	4500183	RNU1/4WJ-22,Metal <D>
R9609	443523314	RS1/2WBJ-330,Metal oxide
	Fuse	
R9512	252300	! 2.5A-ULSE-TL250
CIRCUIT NO.	PART NO.	DESCRIPTION
	Terminals	
P2102	25045729	NPJ-10PDBY517
P2104	25045727	NPJ-15PDBY515
P4301	25045303 or	NPJ-4PDBL162 or
	25045575	NPJ-4PDRW389
P4302	25045300 or	NPJ-6PDBL159 or
	25045571	NPJ-6PDRW386
P4303	25045697	NPJ-6PWRLGGP493
P4351	25045794	NPJ-1PDB574
P4352	25045696	LGY2502-0200C
P4602	25045514	YKB26-5005
	Sockets	
P1101	25052211	NSCT-15P2108
P2002	25051529	NSCT-18P1316
P4401A	2009990890AUL	NSAS-30P1374
P4402A,P4402B	25051089	NSCT-5P876
	Plugs	
P2001,P2003	25055807	NPLG-18P763
P7001B	25055155	NPLG-11P139
P7003B	25055153	NPLG-9P137
P9001B	25055133	NPLG-3P117
P9002B	25055132	NPLG-2P116
P9003B	25055134	NPLG-4P118
P7002	25055704	NPLG-8P660
P9101B	25055625	NPLG-4P587
	Heat sinks	
Q9602B	27160551	RAD-201
Q9609A	27160472	RAD-141
	Screws	
Q9602A,Q9604A	82143010	3P+10FN(BC)
Q9605A,Q9606A	82143010	3P+10FN(BC)
Q9609B	82143010	3P+10FN(BC)

POWER SUPPLY CIRCUIT PC BOARD (NAPS-8342-1B/1D/1F/1H/1I)**DISPLAY CIRCUIT PC BOARD (NADIS-8343-1H)****COMPONENT VIDEO PC BOARD (NAVD-8344-1B/1D/1F/1H/1I)****VOLUME PC BOARD (NASW-8345-1B/1D/1F/1I)****DISPLAY CIRCUIT PC BOARD (NADIS-8346-1B/1D/1F/1I)****STANDBY SWITCH PC BOARD (NASW-8347-1B/1D/1F/1I)****STANDBY SWITCH PC BOARD (NASW-8348-1H)**

CIRCUIT NO.	PART NO.	DESCRIPTION
	FL tube	
Q802	212241	HFA-12SM50T <O>
Q8020	212241	HFA-12SM50T <D>
	ICs	
Q2202	22241465R2	LA7106MFP <D>
Q2203	22241851R3	TA1270BF <D>
Q2711	222740046R2	74HCU04F
Q801	22241989R3	MPD780232GC-091-8BT
	Remote sensor	
U8701	241356	PIC-37043TM2 <O>
	241357	PIC-37143TC5 <D>
	Transistors	
Q2201	2216690R2	DTC123JKA
Q2204	2216690R2	DTC123JKA <D>
Q2205	2214530R2	RN2402

Q2206	2214530R2	RN2402 <D>
Q828	2213145R2	2SC2712-GR <O>
Q8280	2213145R2	2SC2712-GR <D>
Q831,Q832,Q833,Q834	2216470R2	DTC114YKA <O>
Q8310,Q8330,Q8340	2216470R2	DTC114YKA <D>
Q9002	2216690R2	DTC123JKA
	Photo couplers	
U2701,U2702	24120101	TORX179L
CIRCUIT NO.	PART NO.	DESCRIPTION
	Diodes	
D2201	223269R2 or 223234R2	1SS355 or 1SS352
D2202	223269R2 or 223234R2	1SS355 or 1SS352 <D>
D831,D832	225321	SLR-342VR <O>
D8310	225321	SLR-342VR <D>
D833,D834	225374	SEL2E10C <O>
D8330,D8340	225437	SELU2E10C-P <D>
D881	224550560R2	UDZS5.6B <O>
D8810	224550560R2	UDZS5.6B <D>
D899	223269R2 or 223234R2	1SS355 or 1SS352 <O>
D8990	223269R2 or 223234R2	1SS355 or 1SS352 <D>
D9001	22380318R2	S1NB60-4062
D9002,D9101,D9102	223269R2 or 223234R2	1SS355 or 1SS352
D9103	224550510R2 or 224370515R2	UDZS5.1B or RD5.1SBY
	Oscillators	
X2201	3010370	CSBLA503KECZF30 <D>
X2202	3010369	HC-49/U033.579545M <D>
X801	3010343	CSTS0500MG06 <O>
X8010	3010343	CSTS0500MG06 <D>
	Coils	
L2701,L2702	231237M022R2 or	NCH-1471 or
L2750	233533K022R2	NCH-1587-022K
L9001	231345	! NCH-3643
	Power transformer	
T9002	2301539	! NPT-1398P <P/A>
	2301465	! NPT-1398G <T/Q>
	2301780	! NPT-1506D <D>
	Capacitors	
C2202,C2233	332101025R1	CK725B1H-102K1,Ceramic
C2203,C2204,C2205	394741007 or 394641007	CE04W16V10M(SC) or CE04W16V-10M(VR),Elect. <D>
C2206,C2208,C2229	394721017 or 394621017	CE04W6.3V100M(SC) or CE04W6.3V-100M(VR),Elect. <D>
C2207,C2209,C2211	332161040R1	CK725F1E-104Z1,Ceramic <D>
C2210	394744707 or 394644707	CE04W16V47M(SC) or CE04W16V-47M(VR),Elect. <D>
C2212	375522234	MMT50V-223J,Plastic
C2220,C2222	394780227 or 394680227	CE04W50V2.2M(SC) or CE04W50V-2.2M(VR),Elect. <D>
C2221,C2228	375521044	MMT50V-104J,Plastic <D>
C2224,C2230	332161040R1	CK725F1E-104Z1,Ceramic <D>
C2225	374722224	ECQ-B50V-222J,Plastic <D>
C2226	394682297	CE04W50V-0.22M(VR),Elect.
C2227	342105604R1	CC725CH1H-560J1,Ceramic <D>
C2231	332101025R1	CK725B1H-102K1,Ceramic <D>
C2232,C2301,C2302	332161040R1	CK725F1E-104Z1,Ceramic
C2303,C2704,C2705	332161040R1	CK725F1E-104Z1,Ceramic
C2703,C2732	394744707 or 394644707	CE04W16V47M(SC) or CE04W16V-47M(VR),Elect.

CIRCUIT NO.	PART NO.	DESCRIPTION
C2711,C2712	332101035R1	CK725B1H-103K1,Ceramic
C2733,C2751	332161040R1	CK725F1E-104Z1,Ceramic
C2750	342101014R1	CC725CH1H-101J1,Ceramic
C2752	342100802R1	CC725CH1H-080D1,Ceramic
C806,C807,C808	342103304R1	CC725CH1H-330J1,Ceramic <O>
C8060,C8070,C8080	342103304R1	CC725CH1H-330J1,Ceramic <D>
C809,C810	342103304R1	CC725CH1H-330J1,Ceramic <O>
C8090,C8100	342103304R1	CC725CH1H-330J1,Ceramic <D>
C821,C824,C884	332161040R1	CK725F1E-104Z1,Ceramic <O>
Capacitors		
C8210,R8240,R8241	332161040R1	CK725F1E-104Z1,Ceramic <D>
C851,C852	342101024R1	CC725CH1H-102J1,Ceramic <O>
C8510,C8520	342101024R1	CC725CH1H-102J1,Ceramic <D>
C8701,C891	355721019	CE04W6.3V-100M,Elect. <O>
C8702	332161040R1	CK725F1E-104Z1,Ceramic <O>
C8711,C8910	355721019	CE04W6.3V-100M,Elect. <D>
C8712,C8840,C8850	332161040R1	CK725F1E-104Z1,Ceramic <D>
C881,C882,C883	342101014R1	CC725CH1H-101J1,Ceramic <O>
C8810,C8820,C8830	342101014R1	CC725CH1H-101J1,Ceramic <D>
C885,C892	332161040R1	CK725F1E-104Z1,Ceramic <O>
C8920	332161040R1	CK725F1E-104Z1,Ceramic <D>
C893	355783309	CE04W50V-33M,Elect. <O>
C8930	355783309	CE04W50V-33M,Elect. <D>
C9002	3500222S	! DE1E3KX472MB5BA01,IS
C9003	374722234	ECQ-B50V-223J,Plastic
C9005	394641027 or 394741027	CE04W16V-1000M(VR) or CE04W16V1000M(SC),Elect.
C9006,C9009	3500196S or 3500202S	! RE275V-103M or ! MKP R46 103M,IS
C9007,C9010	332161040R1	CK725F1E-104Z1,Ceramic
C9101	394641007 or 394741007	CE04W16V-10M(VR) or CE04W16V10M(SC),Elect.
Resistors		
R2202,R2203,R2204	435036804R1	RN72K1J-680JE,Carbon <D>
R2205,R8750	435038214R1	RN72K1J-821JE,Carbon <D>
R2206,R8740	435031024R1	RN72K1J-102JE,Carbon <D>
R2207,R2237	435033324R1	RN72K1J-332JE,Carbon <D>
R2208,R2209,R2210	435031034R1	RN72K1J-103JE,Carbon <D>
R2221,R2222,R2223	435030004R1	RN72K1J-000JE,Carbon <O>
R2234	435031814R1	RN72K1J-181JE,Carbon <D>
R2236,R2239	435033334R1	RN72K1J-333JE,Carbon <D>
R2238	435031034R1	RN72K1J-103JE,Carbon <D>
R2240	435033344R1	RN72K1J-334JE,Carbon <D>
R2241	435030004R1	RN72K1J-000JE,Carbon <D>
R2243 ,R2244	435037504R1	RN72K1J-750JE,Carbon <D>
R2245,R2246	435031014R1	RN72K1J-101JE,Carbon <D>
R2247,R2248,R2754	435031034R1	RN72K1J-103JE,Carbon
R2722,R2724	435031544R1	RN72K1J-154JE,Carbon
R2723,R2725	435031044R1	RN72K1J-104JE,Carbon
R2750	435037504R1	RN72K1J-750JE,Carbon
R2751	435031004R1	RN72K1J-100JE,Carbon
R2752	435032244R1	RN72K1J-224JE,Carbon
R805	435030004R1	RN72K1J-000JE,Carbon <O>
R8050,R8660	435030004R1	RN72K1J-000JE,Carbon <D>
R806,R807,R808	435034714R1	RN72K1J-471JE,Carbon <O>
R8060,R8070,R8080	435034714R1	RN72K1J-471JE,Carbon <D>
R809,R810,R831	435034714R1	RN72K1J-471JE,Carbon <O>
R8090,R8100,R8310	435034714R1	RN72K1J-471JE,Carbon <D>
R811,R813,R814,R817	435031034R1	RN72K1J-103JE,Carbon <O>
R8110,R8130,R8140	435031034R1	RN72K1J-103JE,Carbon <D>
R816,R872	435033924R1	RN72K1J-392JE,Carbon <O>
R817,R819,R820,R826	435031034R1	RN72K1J-103JE,Carbon <O>
R8170,R8190,R8260	435031034R1	RN72K1J-103JE,Carbon <D>

CIRCUIT NO.	PART NO.	DESCRIPTION
R821,R824	435032724R1	RN72K1J-272JE,Carbon <O>
R8210,R8240,R8241	435032724R1	RN72K1J-272JE,Carbon <D>
R827,R851,R852	435031034R1	RN72K1J-103JE,Carbon <O>
R8270,R8510,R8520	435031034R1	RN72K1J-103JE,Carbon <D>
R828	435031044R1	RN72K1J-104JE,Carbon <O>
R8280	435031044R1	RN72K1J-104JE,Carbon <D>
R832,R833,R834	435033314R1	RN72K1J-331JE,Carbon <O>
R8330,R8340	435033314R1	RN72K1J-331JE,Carbon <D>
R853,R854,R871	435031034R1	RN72K1J-103JE,Carbon <O>
R8530,R8540,R8710	435031034R1	RN72K1J-103JE,Carbon <D>
Resistors		
R861,R876	435034714R1	RN72K1J-471JE,Carbon <O>
R8610,R8760	435034714R1	RN72K1J-471JE,Carbon <D>
R862,R877	435033914R1	RN72K1J-391JE,Carbon <O>
R8620,R8650,R8770	435033914R1	RN72K1J-391JE,Carbon <D>
R8701,R8702	435031014R1	RN72K1J-101JE,Carbon <O>
R8711,R8712	435031014R1	RN72K1J-101JE,Carbon <D>
R8720	435033924R1	RN72K1J-392JE,Carbon <D>
R873	435031824R1	RN72K1J-182JE,Carbon <O>
R8730	435031824R1	RN72K1J-182JE,Carbon <D>
R874	435031024R1	RN72K1J-102JE,Carbon <O>
R875	435038214R1	RN72K1J-821JE,Carbon <O>
R8750	435038214R1	RN72K1J-821JE,Carbon <D>
R881,R882	435034714R1	RN72K1J-471JE,Carbon <O>
R8810,R8820	435034714R1	RN72K1J-471JE,Carbon <D>
R8901	435031044R1	RN72K1J-104JE,Carbon <O>
R8901,R8902	435031044R1	RN72K1J-104JE,Carbon <O>
R8903,R8904	435031044R1	RN72K1J-104JE,Carbon
R8911,R8912	435031044R1	RN72K1J-104JE,Carbon <D>
R8913,R8914	435031044R1	RN72K1J-104JE,Carbon
R897	435031054R1	RN72K1J-105JE,Carbon <O>
R8970	435031054R1	RN72K1J-105JE,Carbon <D>
R9002	453532294	RNU1/2WCJ-0.22,Metal
R9101,R9102,R9103	435033914R1	RN72K1J-391JE,Carbon
R9104	435032224R1	RN72K1J-222JE,Carbon
Relays		
RL2201,RL2202	25065645 or 25065654 or 25065658	NPL-2P1A-DC4.5-169 or NRL-2P2A-DC4.5-172 or NRL-2P2A-DC4.5-173
RL2203,RL2204	25065645 or 25065654 or 25065658	NPL-2P1A-DC4.5-169 or NRL-2P2A-DC4.5-172 or NRL-2P2A-DC4.5-173 <D>
RL9001	25065669 !	NRL-1P5A-DC9-179
Rotary encoder		
S851	25065667	EC12E2420 <O>
S8510	25065667	EC12E2420 <D>
Switches		
S861,S862,S871,S872	25035718	NPS-111-S681 <O>
S873,S874,S875,S876	25035718	NPS-111-S681 <O>
S877,S878	25035718	NPS-111-S681 <O>
S8610,S8620,S8650	25035718	NPS-111-S681 <D>
S8660,S8710,S8720	25035718	NPS-111-S681 <D>
S8740,S8750,S8760	25035718	NPS-111-S681 <D>
Fuse holders		
F9001A,F9001B	25052133 !	NSCT-1P2031
Terminals		
P2301,P2302,P2303	25045629	NPJ-3PDGLR436
P2703	25045473	NPJ-1PDBL291
Sockets		
P2004	25051529	NSCT-18P1316
P7001A	2002E392240UL	NSAS-22P1419 <O>
P7001C	2002E392220UL	NSAS-22P1420 <D>
P831	200EE391006UL	NSAS-10P1438 <O>

P8310A	2002E391005UL	NSAS-10P1441 <D>
P851	200EE390606UL	NSAS-6P1437 <O>
P9101A	25051088	NSCT-4P875

Plugs

P8310B	25055369	NPLG-5P352 <D>
P9301B,P9302B	25055675	NPLG-2P631

Label

F9001C	29361769	T1.6AL250V <O>
--------	----------	----------------

Cushions

E8020A,E8020B	28141531	<D>
E802A,E802B	28141531	<O>

DIGITAL AMPLIFIER PC BOARD (NAAF-8350-1B/1D/1F/1H/1I)
FRONT SPEAKER TERMINAL PC BOARD (NAETC-8351-1B/1D/1F/1I)
SPEAKER TERMINAL PC BOARD (NAETC-8352-1B/1D/1F/1H/1I)

CIRCUIT NO.	PART NO.	DESCRIPTION
ICs		
Q5001,Q5003,Q5005	22242022R2	TC2001
Q5101,Q5103,Q5105	22242023R2	TP2150B
Q5911	222780055JRC	78M05(NJM78M05FA)

Transistors

Q5301,Q5303,Q5305	2215410R2	RN1441
Q5401,Q5402,Q5403	2203880	IRF530N
Q5404,Q5405,Q5406	2203880	IRF530N
Q5411,Q5412,Q5413	2203880	IRF530N
Q5414,Q5415,Q5416	2203880	IRF530N
Q5713	2203820	IRF9520N
Q5801,Q5802,Q5803	2216690R2	DTC123JKA
Q5804	2216690R2	DTC123JKA <D>
Q5811,Q5812,Q5852	2214530R2	RN2402
Q5814	2214530R2	RN2402 <D>
Q5851	2216690R2	DTC123JKA

Diodes

D5301,D5303,D5305	223269R2 or	1SS355 or
D5801,D5802,D5803	223234R2	1SS352
D5421,D5422,D5423	223276R2	M1FL20U
D5424,D5425,D5426	223276R2	M1FL20U
D5431,D5432,D5433	223276R2	M1FL20U
D5434,D5435,D5436	223276R2	M1FL20U
D5441,D5442,D5443	223276R2	M1FL20U
D5444,D5445,D5446	223276R2	M1FL20U
D5713,D5721,D5723	223276R2	M1FL20U
D5725	223276R2	M1FL20U
D5731,D5733,D5735	223276R2	M1FL20U
D5804	223269R2 or	1SS355 or
	223234R2	1SS352 <D>
D5851,D5852	223269R2 or	1SS355 or
	223234R2	1SS352
D5901	22380337	D10XB60H
D5911	22380318R2	S1NB60-4062

Coils

L5501,L5502,L5503	231343L220	NCH-1641
L5504,L5505,L5506	231343L220	NCH-1641
L5521,L5522,L5523	231350	NCH-1647
L5524,L5525,L5526	231350	NCH-1647
L5601,L5602	231350	NCH-1647 <D>
L5603,L5604,L5605	231350	NCH-1647
L5606	231350	NCH-1647
L5607,L5608	231350	NCH-1647 <D>
L5651,L5652	231350	NCH-1647 <O>
L5703	231311K101	NCH-3589K101
L5911,L5912	231237K220R2	NCH-1477

Capacitors

C5001,C5003,C5005	332121045R1	CK725B1C-104K1,Ceramic
C5011,C5013,C5015	342102214R1	CC725CH1H-221J1,Ceramic

C5021,C5023,C5025	342102214R1	CC725CH1H-221J1,Ceramic
C5031,C5033,C5035	374721044	ECQ-V50V-104J,Plastic
C5041,C5043,C5045	394624707 or 394744707	CE04W6.3V-47M(VR) or CE04W16V47M(SC),Elect.
C5101,C5102,C5103	393380227	CE04W50V-2.2M(VX),Elect.
C5104,C5105,C5106	393380227	CE04W50V-2.2M(VX),Elect.
C5111,C5112,C5113	332121045R1	CK725B1C-104K1,Ceramic
C5114,C5115,C5116	332121045R1	CK725B1C-104K1,Ceramic
C5203,C5205	332121045R1	CK725B1C-104K1,Ceramic
C5301	342104714R1	CC725CH1H-471J1,Ceramic <P>
C5301,C5303,C5305	342101814R1	CC725CH1H-181J1,Ceramic <D/T/A/Q>
C5302	342101814R1	CC725CH1H-181J1,Ceramic <P>
CIRCUIT NO.	PART NO.	DESCRIPTION
	Capacitors	
C5302,C5304,C5306	342102214R1	CC725CH1H-221J1,Ceramic <D/T/A/Q>
C5303	342103314R1	CC725CH1H-331J1,Ceramic <P>
C5304	342101014R1	CC725CH1H-101J1,Ceramic <P>
C5305	342102214R1	CC725CH1H-221J1,Ceramic
C5306	342103304R1	CC725CH1H-330J1,Ceramic <P>
C5361,C5363,C5365	332161040R1	CK725F1E-104Z1,Ceramic
C5411,C5413,C5415	332161040R1	CK725F1E-104Z1,Ceramic
C5501,C5502,C5503	394593307	CE04W100V-33M(VZ),Elect.
C5504,C5505,C5506	394593307	CE04W100V-33M(VZ),Elect.
C5511,C5512,C5513	374731044	ECQ-V100-104J,Plastic
C5514,C5515,C5516	374731044	ECQ-V100-104J,Plastic
C5551,C5552,C5553	374721544	ECQ-V50V-154J,Plastic
C5554,C5555,C5556	374721544	ECQ-V50V-154J,Plastic
C5561,C5562,C5563	374721544	ECQ-V50V-154J,Plastic
C5564,C5565,C5566	374721544	ECQ-V50V-154J,Plastic
C5601,C5602	374721024	ECQ-B50V-102J,Plastic <D>
C5603,C5604	374721024	ECQ-B50V-102J,Plastic
C5605,C5606	374721024	ECQ-B50V-102J,Plastic
C5607,C5608	374721024	ECQ-B50V-102J,Plastic
C5611,C5612	342111024R1	CC725CH1E-102J1,Ceramic <D>
C5613,C5614	342111024R1	CC725CH1E-102J1,Ceramic
C5615,C5616	342111024R1	CC725CH1E-102J1,Ceramic
C5617,C5618	342111024R1	CC725CH1E-102J1,Ceramic <D>
C5651,C5652	374721024	ECQ-B50V-102J,Plastic <O>
C5671,C5672	342111024R1	CC725CH1E-102J1,Ceramic <O>
C5711,C5715	394664707 or 394764707	CE04W35V-47M(VR) or CE04W35V47M(SC),Elect.
C5713	394661017 or 394761017	CE04W35V-100M(VR) or CE04W35V100M(SC),Elect.
C5721,C5723,C5725	332161040R1	CK725F1E-104Z1,Ceramic
C5733	374721044	ECQ-V50V-104J,Plastic
C5741,C5743,C5745	394664707 or 394764707	CE04W35V-47M(VR) or CE04W35V47M(SC),Elect.
C5751,C5753,C5755	374721044	ECQ-V50V-104J,Plastic
C5761,C5763,C5765	394664707 or 394764707	CE04W35V-47M(VR) or CE04W35V47M(SC),Elect.
C5771,C5773,C5775	374721044	ECQ-V50V-104J,Plastic
C5801,C5802,C5803	332161040R1	CK725F1E-104Z1,Ceramic
C5804	332161040R1	CK725F1E-104Z1,Ceramic <D>
C5851,C5852,C5913	332161040R1	CK725F1E-104Z1,Ceramic
C5901,C5902,C5911	374723344	ECQ-V50V-334J,Plastic
C5903,C5904	3504406	CE69W50V-10000M,Elect.
C5912	394642227S	CE04W16V-2200M(VR),Elect.
C5914	394621017 or 394721017	CE04W6.3V-100M(VR) or CE04W6.3V100M(SC),Elect.
C5931,C5933,C5935	332121045R1	CK725B1C-104K1,Ceramic
	Resistors	
C5201	435030004R1	RN72K1J-000JE,Carbon
R5011,R5013,R5015	435032734R1	RN72K1J-273JE,Carbon
R5021,R5023,R5025	435032734R1	RN72K1J-273JE,Carbon

CIRCUIT NO.	PART NO.	DESCRIPTION
R5031,R5033,R5035	435038222R1	RN72K1J-822FE,Carbon
R5041,R5043,R5045	435030474R1	RN72K1J-047JE,Carbon
R5101,R5102,R5103	435032234R1	RN72K1J-223JE,Carbon
R5104,R5105,R5106	435032234R1	RN72K1J-223JE,Carbon
R5111,R5112,R5113	435031054R1	RN72K1J-105JE,Carbon
R5114,R5115,R5116	435031054R1	RN72K1J-105JE,Carbon
R5121,R5122,R5123	5210265	N06HR50KBC,Trimming
R5124,R5125,R5126	5210265	N06HR50KBC,Trimming
R5131,R5132,R5133	435032232R1	RN72K1J-223FE,Carbon
R5134,R5135,R5136	435032232R1	RN72K1J-223FE,Carbon
R5291,R5293,R5295	435032234R1	RN72K1J-223JE,Carbon
R5292,R5294,R5296	435031034R1	RN72K1J-103JE,Carbon
R5301,R5302,R5303	435031024R1	RN72K1J-102JE,Carbon
CIRCUIT NO.	PART NO.	DESCRIPTION
	Resistors	
R5304,R5305,R5306	435031024R1	RN72K1J-102JE,Carbon
R5311,R5312,R5313	435031024R1	RN72K1J-102JE,Carbon
R5314,R5315,R5316	435031024R1	RN72K1J-102JE,Carbon
R5321,R5322,R5323	435032224R1	RN72K1J-222JE,Carbon
R5324,R5325,R5326	435032224R1	RN72K1J-222JE,Carbon
R5331,R5332,R5333	435032224R1	RN72K1J-222JE,Carbon
R5334,R5335,R5336	435032224R1	RN72K1J-222JE,Carbon
R5341,R5342,R5343	435032224R1	RN72K1J-222JE,Carbon
R5344,R5345,R5346	435032224R1	RN72K1J-222JE,Carbon
R5351,R5352,R5353	435032224R1	RN72K1J-222JE,Carbon
R5354,R5355,R5356	435032224R1	RN72K1J-222JE,Carbon
R5361,R5363,R5365	435032224R1	RN72K1J-222JE,Carbon
R5401,R5402,R5403	443521504	RS1/2WBJ-15,Metal oxide
R5404,R5405,R5406	443521504	RS1/2WBJ-15,Metal oxide
R5411,R5412,R5413	443521504	RS1/2WBJ-15,Metal oxide
R5414,R5415,R5416	443521504	RS1/2WBJ-15,Metal oxide
R5521,R5522,R5523	4000231R2	PMR100HZPFU10L0
R5524,R5525,R5526	4000231R2	PMR100HZPFU10L0
R5531,R5532,R5533	4000231R2	PMR100HZPFU10L0
R5534,R5535,R5536	4000231R2	PMR100HZPFU10L0
R5551,R5552,R5553	442722204F	RS2WBJ-22,Metal oxide
R5554,R5555,R5556	442722204F	RS2WBJ-22,Metal oxide
R5561,R5562,R5563	435032234R1	RN72K1J-223JE,Carbon
R5564,R5565,R5566	435032234R1	RN72K1J-223JE,Carbon
R5571,R5572,R5573	435031034R1	RN72K1J-103JE,Carbon
R5574,R5575,R5576	435031034R1	RN72K1J-103JE,Carbon
R5581,R5582,R5583	435031834R1	RN72K1J-183JE,Carbon
R5584,R5585,R5586	435031834R1	RN72K1J-183JE,Carbon
R5611,R5612	435031004R1	RN72K1J-100JE,Carbon <D>
R5613,R5614	435031004R1	RN72K1J-100JE,Carbon
R5615,R5616,R5703	435031004R1	RN72K1J-100JE,Carbon
R5617,R5618	435031004R1	RN72K1J-100JE,Carbon <D>
R5671,R5672	435031004R1	RN72K1J-100JE,Carbon <O>
R5713	435031024R1	RN72K1J-102JE,Carbon
R5721,R5723,R5725	435032714R1	RN72K1J-271JE,Carbon
R5751,R5753,R5755	435032714R1	RN72K1J-271JE,Carbon
R5761,R5765	435030474R1	RN72K1J-047JE,Carbon
R5781	435032234R1	RN72K1J-223JE,Carbon
R5801,R5802,R5803	443621214	RS1WBJ-120,Metal oxide
R5804	443621214	RS1WBJ-120,Metal oxide <D>
R5811 ,R5812,R5813	443523304	RS1/2WBJ-33,Metal oxide
R5814,R5815,R5816	443523304	RS1/2WBJ-33,Metal oxide
R5817,R5818,R5819	443523304	RS1/2WBJ-33,Metal oxide
R5820,R5821,R5822	443523304	RS1/2WBJ-33,Metal oxide
R5823,R5826,R5827	443523304	RS1/2WBJ-33,Metal oxide
R5851,R5852	443525614	RS1/2WBJ-560,Metal oxide
R5861,R5862,R5863	435031014R1	RN72K1J-101JE,Carbon
R5901,R5902	443528224	RS1/2WBJ-8.2K,Metal oxide
R5911	453530104	RNU1/2WCJ-1,Metal

Relays		
RL5801,RL5802 RL5803	25065632 or 25065607 or 25065598	NRL-2P5A-DC12-160 or NRL-2P5A-DC12-155 or NRL-2P3A-DC12-148
RL5804	25065632 or 25065607 or 25065598	NRL-2P5A-DC12-160 or NRL-2P5A-DC12-155 or NRL-2P3A-DC12-148 <D>
RL5851,RL5852	25065664	NRL-2P2A-DC12-178
Terminals		
P5501	25060408	NTM-8PDML337
P5511	25060407	NTM-8PDML336 <D>
P5512	25060385	NTM-4PDMN316 <P/T/A/Q>

CIRCUIT NO.	PART NO.	DESCRIPTION
Sockets		
P5601A	2009990889UL	NSAS-8P1373
P5603A	2009990888UL	NSAS-8P1372
P5605A	2009990887UL	NSAS-8P1371
P5651A	25051108	NSCT-4P895 <P/T/A/Q>
P5651B	25050268	NSCT-4P96 <P/T/A/Q>
P7003A	2002A291830UL	NSAS-18P1421
Plugs		
P4401	25055158	NPLG-14P142
P9501B	25055166	NPLG-3P150
P9502B	25055132	NPLG-2P116
Isolated sheets		
Q5401B,Q5402B,Q5403B	223037	M80 D-2
Q5404B,Q5405B,Q5406B	223037	M80 D-2
Q5411B,Q5412B,Q5413B	223037	M80 D-2
Q5414B,Q5415B,Q5416B	223037	M80 D-2
Retainer		
P9901	27141956	(BUS)
Heat sinks		
D5901A	27160271	RAD-083
Q5401D,Q5403D,Q5405D	27160551	RAD-201
Accessories		
Q5401A,Q5402A,Q5403A	223033	AC316A,Transistor
Q5404A,Q5405A,Q5406A	223033	AC316A,Transistor
Q5411A,Q5412A,Q5413A	223033	AC316A,Transistor
Q5414A,Q5415A,Q5416A	223033	AC316A,Transistor
Screws		
Q5401C,Q5402C,Q5403C	82143010	3P+10FN(BC),Pan head
Q5404C,Q5405C,Q5406C	82143010	3P+10FN(BC),Pan head
Q5411C,Q5412C,Q5413C	82143010	3P+10FN(BC),Pan head
Q5414C,Q5415C,Q5416C	82143010	3P+10FN(BC),Pan head
D5901B	82143010	3P+10FN(BC),Pan head