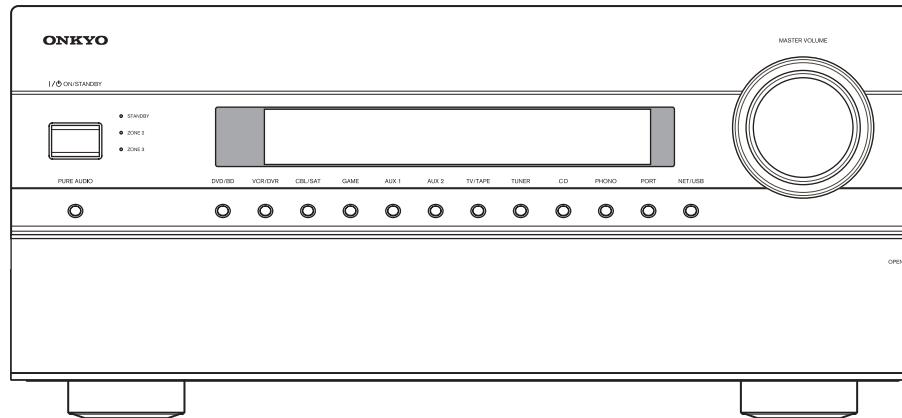
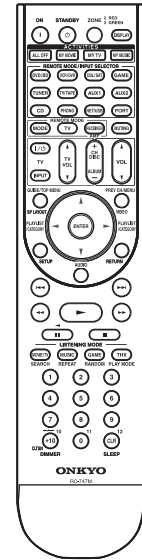

# ONKYO SERVICE MANUAL

## AV RECEIVER MODEL TX-NR3007(B)/(S)

**Black and Silver models**

RC-747M

B MDC	120V AC, 60Hz
B MMP, S MMP	220-240V AC, 50/60Hz
B MMO	220-240V AC, 50/60Hz

### SAFETY-RELATED COMPONENT WARNING!!

COMPONENTS IDENTIFIED BY MARK  ON THE SCHEMATIC DIAGRAM AND IN THE PARTS LIST ARE CRITICAL FOR RISK OF FIRE AND ELECTRIC SHOCK. REPLACE THESE COMPONENTS WITH ONKYO PARTS WHOSE PART NUMBERS APPEAR AS SHOWN IN THIS MANUAL.

MAKE LEAKAGE-CURRENT OR RESISTANCE MEASUREMENTS TO DETERMINE THAT EXPOSED PARTS ARE ACCEPTABLY INSULATED FROM THE SUPPLY CIRCUIT BEFORE RETURNING THE APPLIANCE TO THE CUSTOMER.

## SERVICE PROCEDURE-1

### 1. Replacing the fuses

 This symbol located near the fuse indicates that the fuse used is show operating type, For continued protection against fire hazard, replace with same type fuse, For fuse rating, refer to the marking adjacent to the symbol.

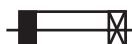
 Ce symbole indique que le fusible utilise est e lent. Pour une protection permanente, n'utiliser que des fusibles de meme type. Ce demier est indique la qu le present symbol est apposse.

REF NO.	PART NAME	DESCRIPTION	PART NO.	REMARKS
F2001	FUSE	4A-UL/T-233	252325GR	!
F2001 or	FUSE	4A-T/UL-ST2	252257GR	!
F2004, 2005	FUSE	1.25A-UL/T-233	252318GR	!
F2004, 2005 or	FUSE	1.25A-T/UL-ST2	252251GR	!
F6601, 6602, 6603, 6604	FUSE	20A-UL-250V	252304GR	!
F9100	FUSE	6.3A-SE-EAK	252079GR	!, <MMP, MMO>
F9100 or	FUSE	6.3A-SE-TL250V	252279GR	!, <MMP, MMO>
F9100	FUSE	12A-UL-ST6	252340GR	!, <MDC>
F9301, 9401, 9402	FUSE	3.15A-UL/T-233	252323GR	!
F9301, 9401, 9402 or	FUSE	3.15A-T/UL-ST2	252256GR	!

#### <Notes>

- <MDC> : Canadian model
- <MMP> : European model
- <MMO> : Asian model

### 2. Safety check out

(U.S.A. model only)

After correcting the original service problem, perform the following safety check before releasing the unit to the customer.

Leakage current Check

Measure the leakage current to a known earth ground (water pipe or conduct etc.) by connecting a leakage current tester between the earth ground and exposed metal parts of the unit (input/output ground terminals, screw heads or metal overlays etc.).

Plug the power supply cord directly into a 120Vac 60Hz wall socket and turn ON/STANDBY button on.

Any current measured must not exceed 0.5mA.

### 3. Memory Backup

This model uses a EE-PROM IC in order to retain radio presets and other settings. So, memory contents will be kept eternally with no care.

### 4. To initialize the unit

1. Press and hold down VCR/DVR button, then press ON/STANDBY button when the unit is powered on.
2. After " *Clear* " is displayed, the preset memory and each mode stored in the memory, are initialized and will return to the factory settings.

## SERVICE PROCEDURE-2

### 5. To check version of Microprocessor, DSP and Video FW(Firmware)

1. Press and hold down DISPLAY button, then press ON/STANDBY button when the unit is power on.  
The main microprocessor version will be displayed on Front Display for about 3 seconds.

[e.g.] 

<i>Main:</i> 1.22/09Z11AH
------------------------------

#### 2. [TX-NR1007, NR3007, NR5007, PR-SC5507]

Press ►(TONE) button while the version is displayed. Then, version of DSP FW will be displayed.

In this way, as ►(TONE) button is pressed while a version is displayed, the next information will be displayed.

If ◀(TONE) button is pressed, the order will be reversed.

#### [DTR-70.1, DTR-80.1, DHC-80.1]

Press +(Tone) button while the version is displayed. Then, version of DSP FW will be displayed.

In this way, as +(Tone) button is pressed while a version is displayed, the next information will be displayed.

If -(Tone) button is pressed, the order will be reversed.

[e.g.] In case TX-NR5007

<Note> Number depends on the version.

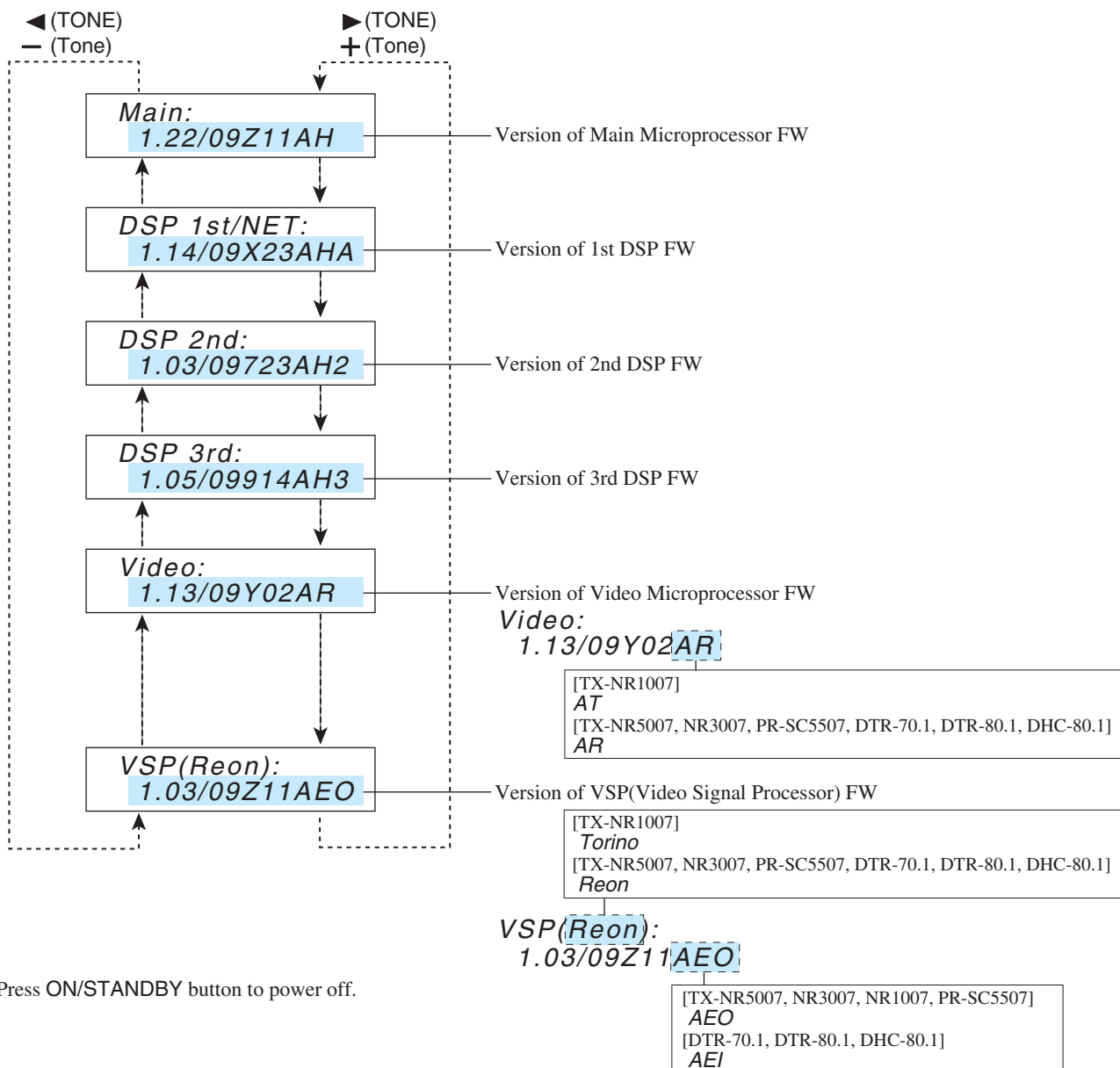

3. Press ON/STANDBY button to power off.

## SERVICE PROCEDURE-3

### 6. Replacing Power Amplifier Parts

When a power amplifier of certain channel is broken and goes into Protect mode, the following parts in the channel must be replaced at the same time, because these parts get damage in most cases.

<Note>

Idling current readjustment is necessary for after repairs.

Center	Sorround R	Front High R	Sorround Back R	Front R	Front L	Sorround Back L	Front High L	Surround L
BACLA-0228	BACLA-0230	BACLA-0234	BACLA-0232	BACLA-0227	BACLA-0226	BACLA-0231	BACLA-0233	BACLA-0229
Q6012, Q6022 Q6032, Q6042 Q6102, Q6112 C6012, C6022 R6052, R6072 R6252, R6262, R6272, R6282, R6292, R6302, R6312	Q6014, Q6024 Q6034, Q6044 Q6104, Q6114 C6014, C6024 R6054, R6074 R6254, R6264, R6274, R6284, R6294, R6304, R6314	Q6018, Q6028 Q6038, Q6048 Q6108, Q6118 C6018, C6028 R6058, R6078 R6258, R6268, R6278, R6288, R6298, R6308, R6318	Q6016, Q6026 Q6036, Q6046 Q6106, Q6116 C6016, C6026 R6056, R6076 R6256, R6266, R6276, R6286, R6296, R6306, R6316	Q6011, Q6021 Q6031, Q6041 Q6101, Q6111 C6011, C6021 R6051, R6071 R6251, R6261, R6271, R6281, R6291, R6301, R6311	Q6010, Q6020 Q6030, Q6040 Q6100, Q6110 C6010, C6020 R6050, R6070 R6250, R6260, R6270, R6280, R6290, R6300, R6310	Q6015, Q6025 Q6035, Q6045 Q6105, Q6115 C6015, C6025 R6055, R6075 R6255, R6265, R6275, R6285, R6295, R6305, R6315	Q6017, Q6027 Q6037, Q6047 Q6107, Q6117 C6017, C6027 R6057, R6077 R6257, R6267, R6277, R6287, R6297, R6307, R6317	Q6013, Q6023 Q6033, Q6043 Q6103, Q6113 C6013, C6023 R6053, R6073 R6253, R6263, R6273, R6283, R6293, R6303, R6313
BAAMP-0191					BAAMP-0192			
Q6052, Q6062, R6402, R6412	Q6054, Q6064, R6404, R6414	Q6058, Q6068, R6408, R6418	Q6056, Q6066, R6406, R6416	Q6051, Q6061, R6401, R6411	Q6050, Q6060, R6400, R6410	Q6055, Q6065, R6405, R6415	Q6057, Q6067, R6407, R6417	Q6053, Q6063, R6403, R6413

[e.g.] In case Front Lch

Refer to "SCHEMATIC DIAGRAMS-1  
AMP1 (VOLTAGE POWER AMP) SECTION"

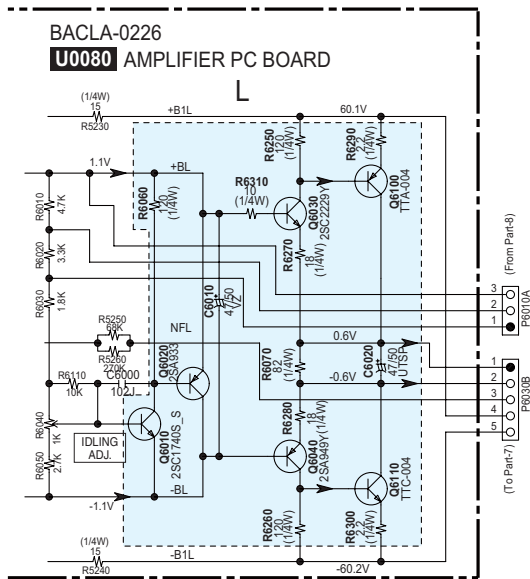

Refer to "SCHEMATIC DIAGRAMS-2  
AMP2 (FINAL STAGE) SECTION"

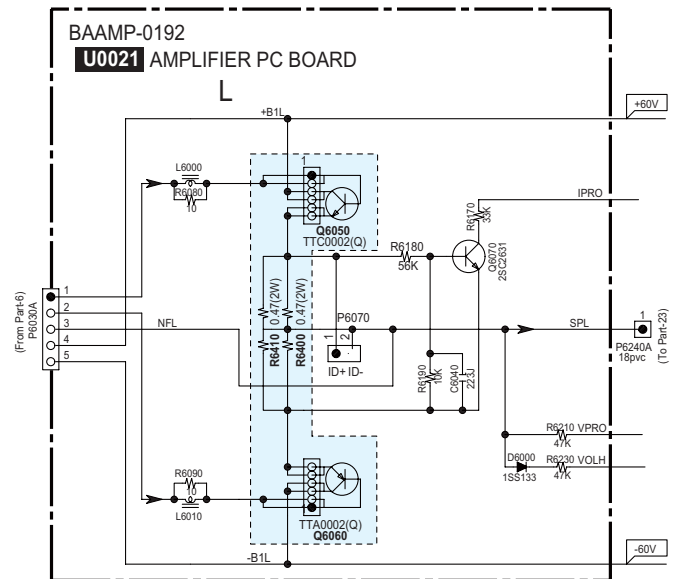

BACLA-0226, BACLA-0229, BACLA-0231 and BACLA-0233 are electrically and mechanically full-compatible with each other, **but idling current readjustment is necessary.**

BACLA-0227, BACLA-0228, BACLA-0230, BACLA-0232 and BACLA-0234 are also electrically and mechanically full-compatible with each other, **but idling current readjustment is necessary.**

**EXPLODED VIEWS-1**

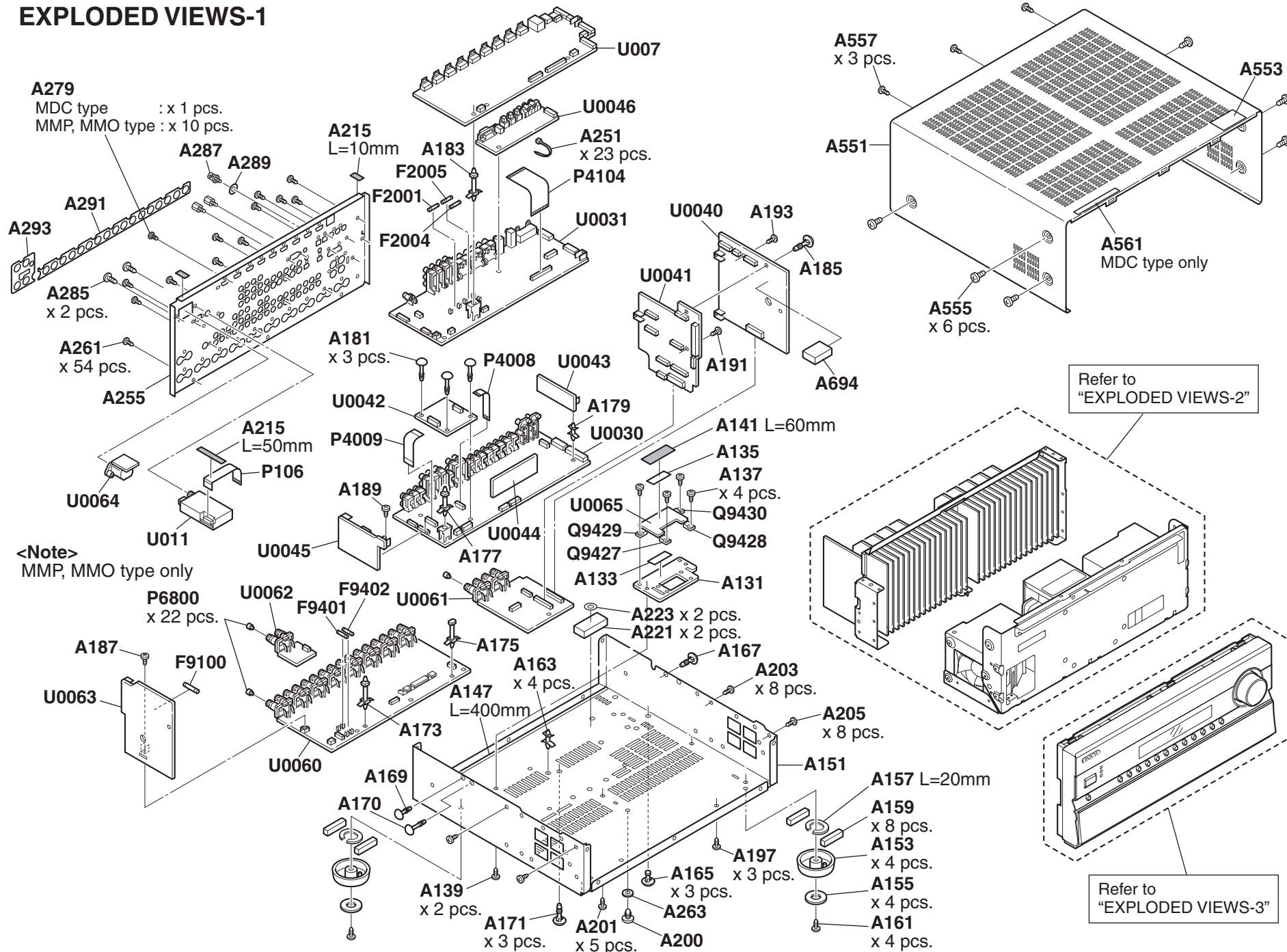

A279  
MDC type : x 1 pcs.  
MMP, MMO type : x 10 pcs.

A215  
L=10mm

A557  
x 3 pcs.

A553

A287  
A289

A251  
x 23 pcs.

A293  
A291

P4104

A285  
x 2 pcs.

F2001  
F2004

U0040  
A193

A551

A561  
MDC type only

A555  
x 6 pcs.

A261  
x 54 pcs.

U0041  
A191

A185

A255

A181  
x 3 pcs.

A694

Refer to  
"EXPLODED VIEWS-2"

A215  
L=50mm

U0043

A141 L=60mm

U0064

P106

A179  
U0030

A135  
A137  
x 4 pcs.

U011

U0045

U0044

U0065

Q9429  
Q9427  
Q9428

<Note>  
MMP, MMO type only

P6800  
x 22 pcs.

U0062  
F9401

F9402  
U0061

A223 x 2 pcs.  
A221 x 2 pcs.

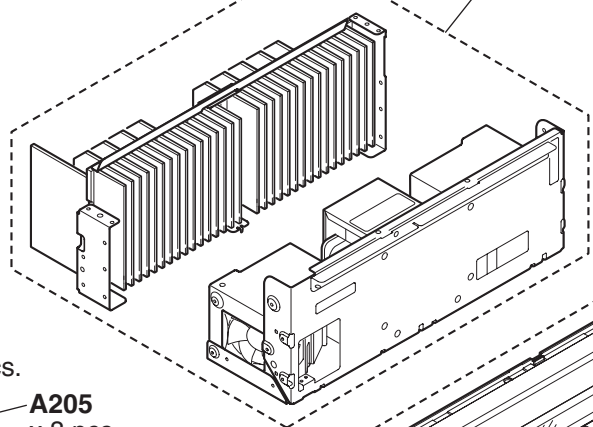

A187

F9100

A175

A163  
x 4 pcs.

A167

A203  
x 8 pcs.

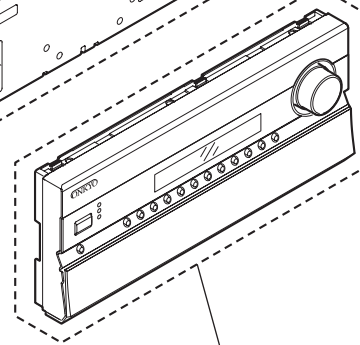

Refer to  
"EXPLODED VIEWS-3"

U0063

U0060

A173

A147  
L=400mm

A151

A205  
x 8 pcs.

A169

A139  
x 2 pcs.

A171  
x 3 pcs.

A201  
x 5 pcs.

A197  
x 3 pcs.

A157 L=20mm  
A159  
x 8 pcs.  
A153  
x 4 pcs.

A155  
x 4 pcs.

A161  
x 4 pcs.

EXPLODED VIEWS-2

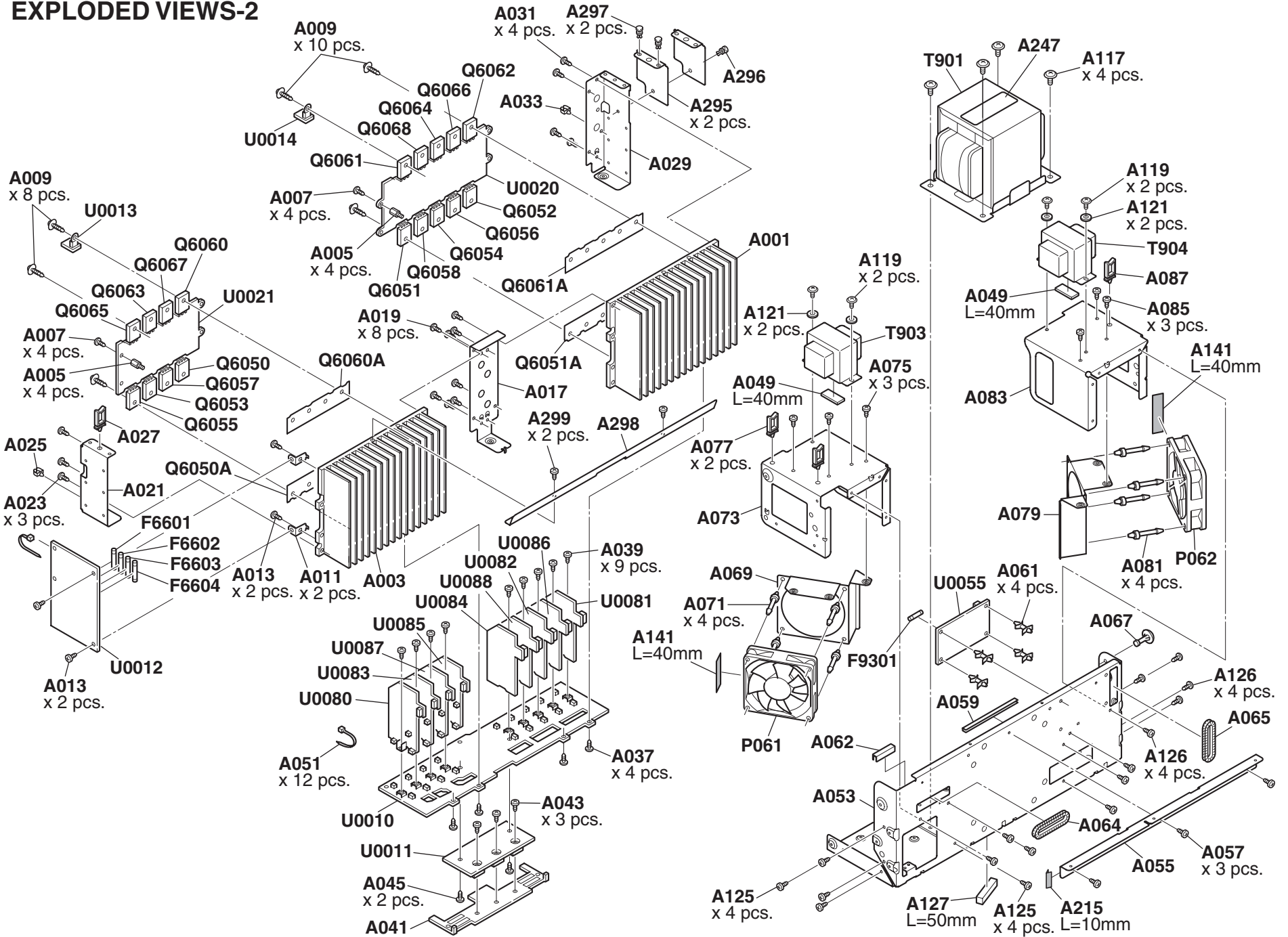

### EXPLODED VIEWS-3

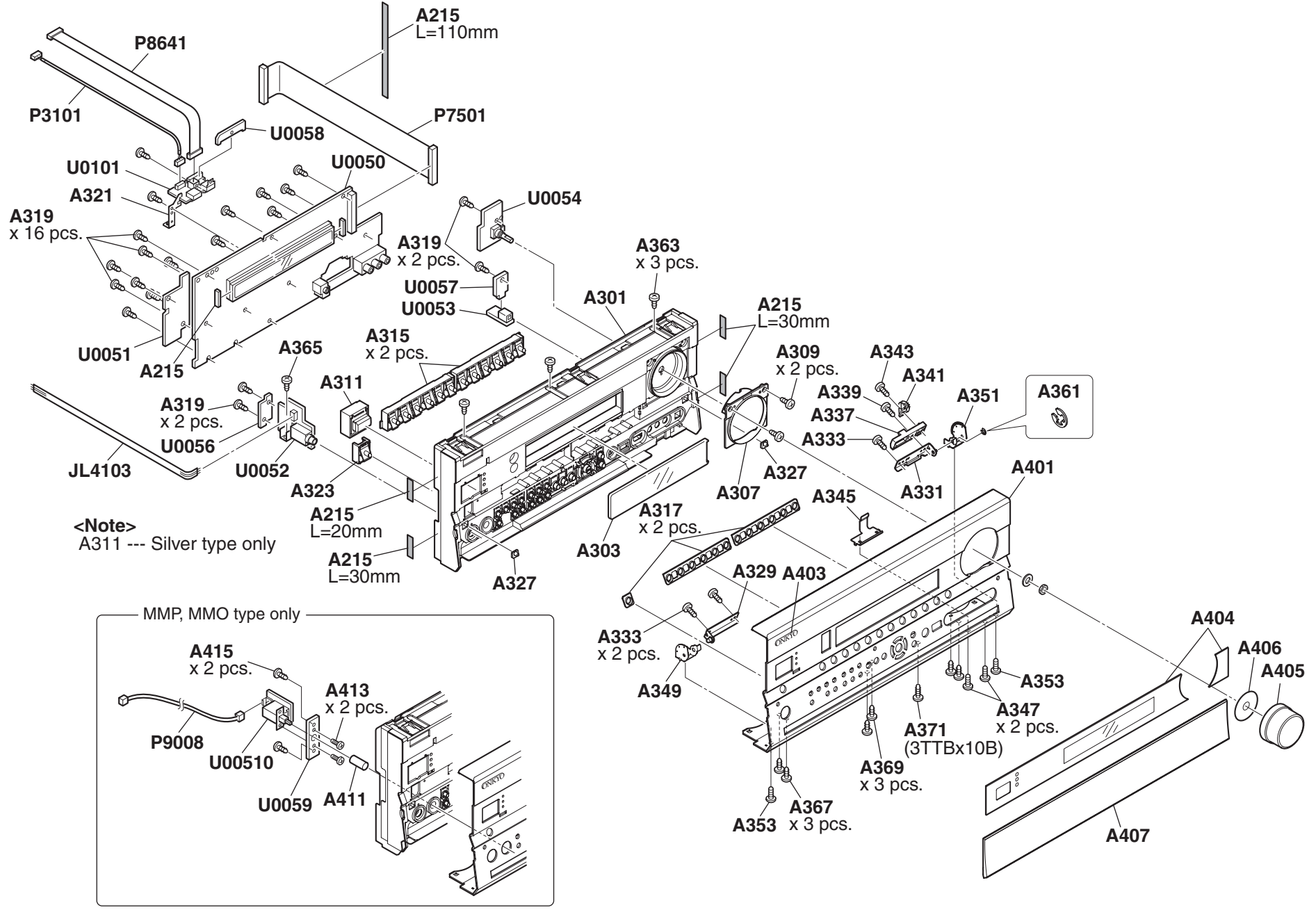

BLOCK DIAGRAMS-1 / PART-1  
AUDIO SECTION

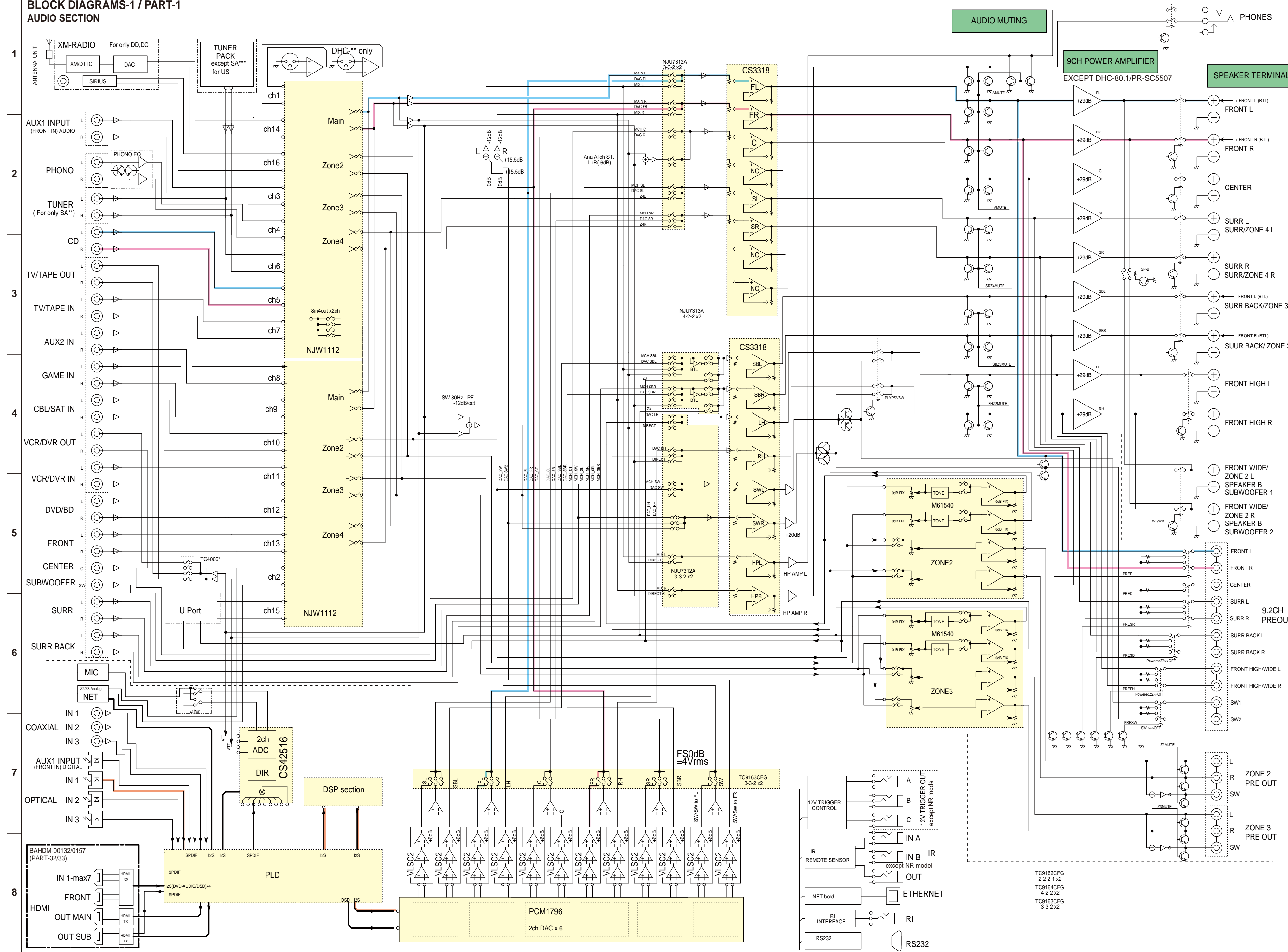

TC9162CFG  
2-2-2-1 x2  
TC9164CFG  
4-2-2 x2  
TC9163CFG  
3-3-2 x2



**BLOCK DIAGRAMS-3 / PART-3**  
**VIDEO SECTION**

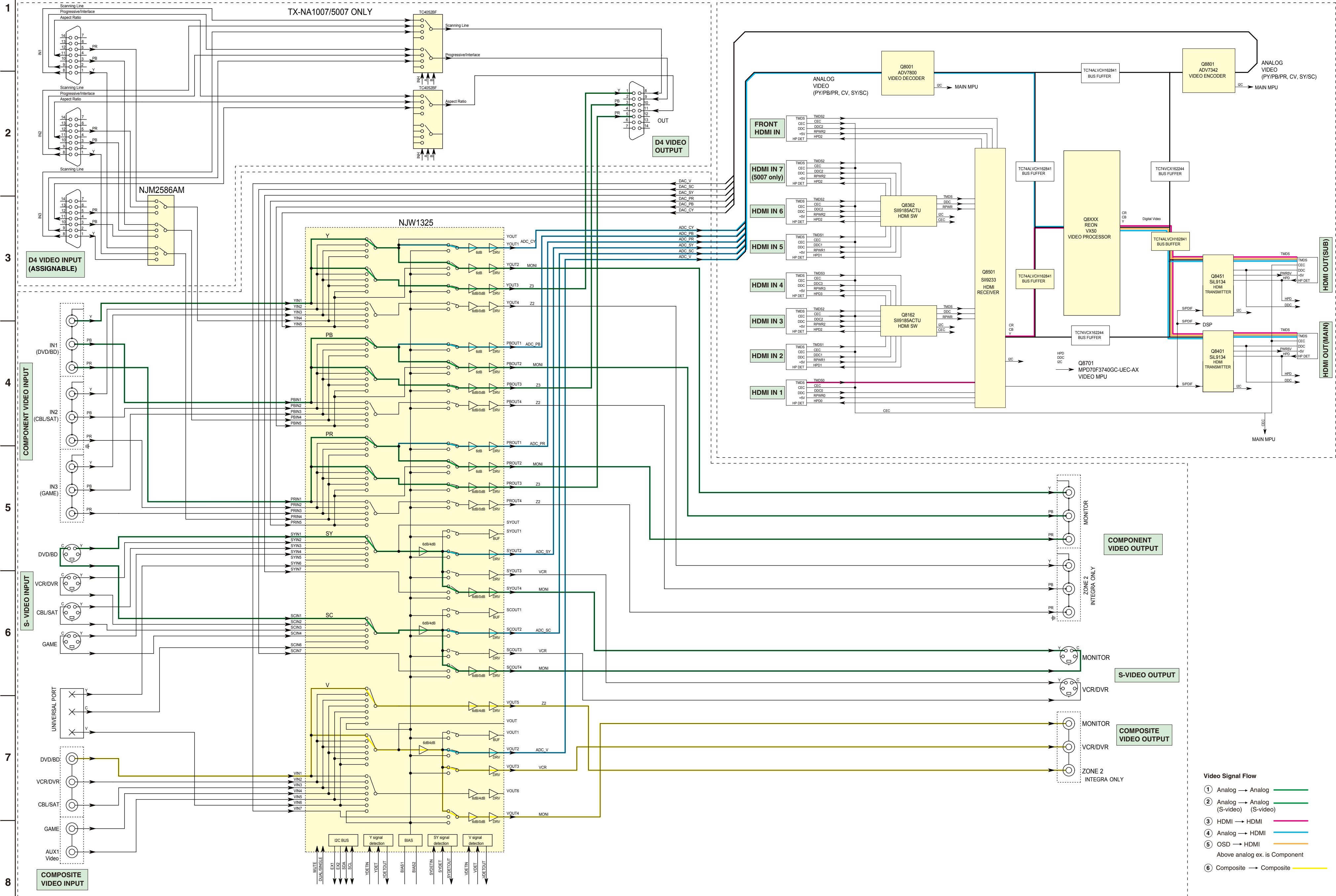

- Video Signal Flow**
- ① Analog → Analog (Green)
  - ② Analog → Analog (S-video) (Light Green)
  - ③ HDMI → HDMI (Pink)
  - ④ Analog → HDMI (Blue)
  - ⑤ OSD → HDMI (Orange)
  - ⑥ Composite → Composite (Yellow)
- Above analog ex. is Component

**BLOCK DIAGRAMS-4 / PART-4**  
**DSP/ETHER/USB/NET SECTION**

1  
2  
3  
4

A B C D E

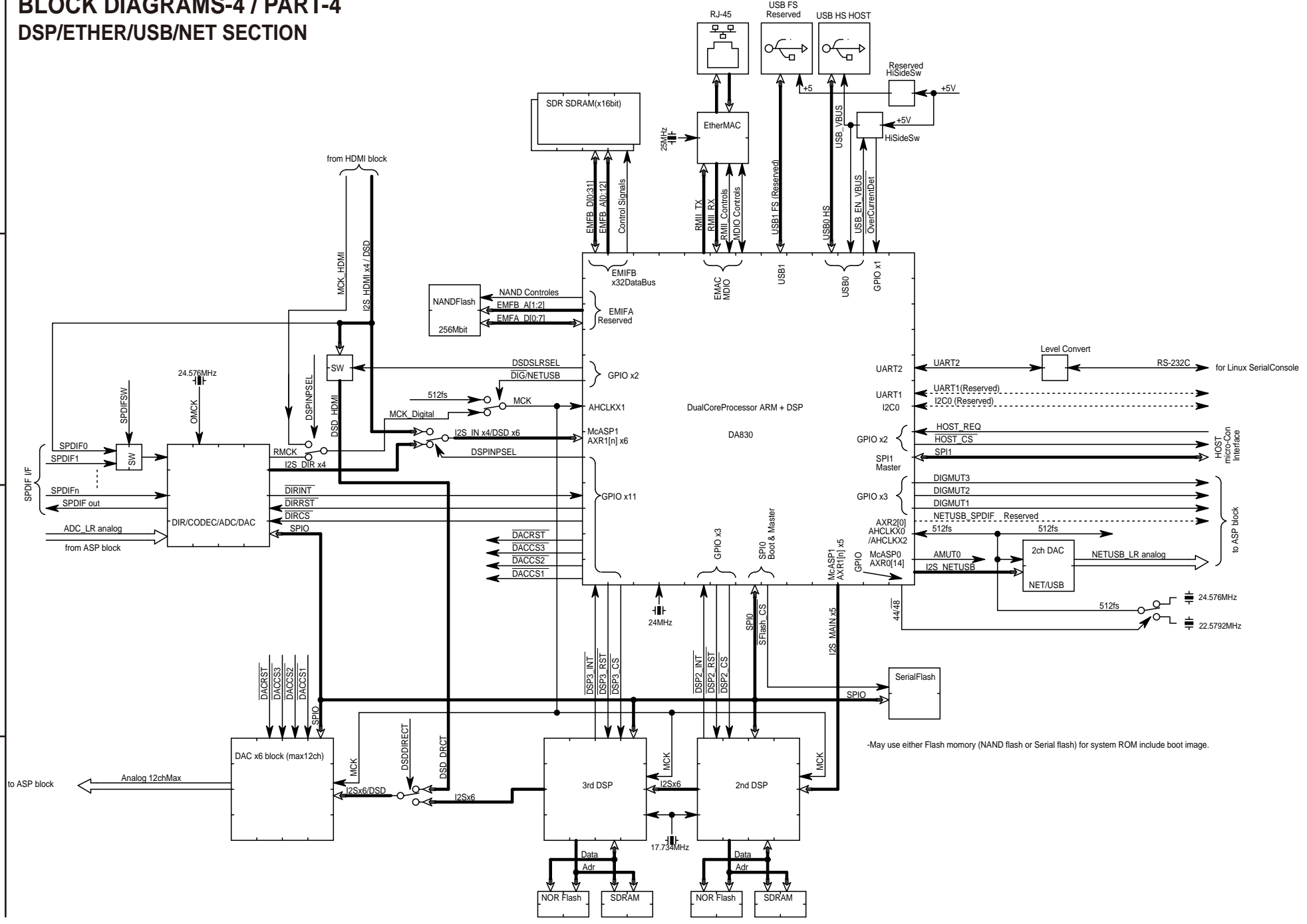

-May use either Flash memory (NAND flash or Serial flash) for system ROM include boot image.

**BLOCK DIAGRAMS-5 / PART-5**  
**DIGITAL AUDIO CLOCK SECTION**

1  
2  
3  
4  
5  
6  
7  
8

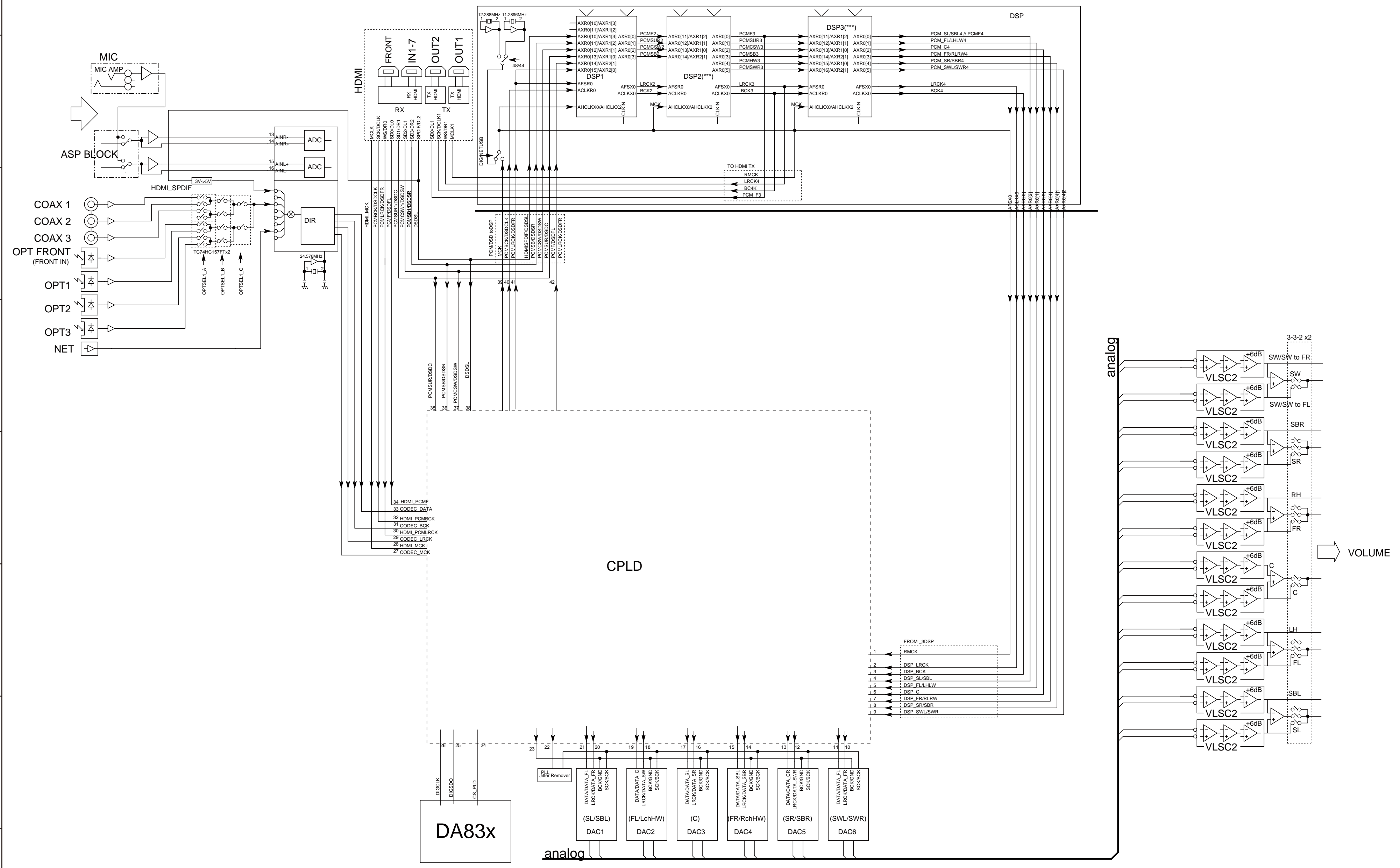

SCHEMATIC DIAGRAMS - 1 / PART-6  
AMP1 (VOLTAGE AMP) SECTION

BACLA-0226

U008 AMPLIFIER PC BOARD

IDLING CURRENT ADJUSTMENT

- Wait for 4 - 6 minutes after power on. (Heat running)
- Re-adjust the trimming resistors according to the following values.

Adjustment point	Measured value	Re-adjustment value
R6040 - R6048	In case below 3 mV	→ 3 mV
	In case 3 - 4 mV	→ No re-adjustment
	In case over 4mV	→ 4 mV

- NOTE
- THE COMPONENTS IDENTIFIED BY MARK  $\Delta$  ARE CRITICAL FOR SAFETY. REPLACE ONLY WITH PART NUMBER SPECIFIED.
  - BOLD VOLTAGE (MEASURED WITH VOLT-METER) IS DC VOLTAGE (NO INPUT SIGNAL).
  - ALL PNP TRANSISTORS ARE EQUIVALENT TO 2SA1015-GR UNLESS OTHERWISE NOTED.
  - ALL NPN TRANSISTORS ARE EQUIVALENT TO 2SC1815-GR UNLESS OTHERWISE NOTED.
  - ALL DIODES ARE EQUIVALENT TO 1SS133 UNLESS OTHERWISE NOTED.
  - ELECTROLYTIC CAPACITORS  $\square$  ARE IN  $\mu$ F/VV.
  - ALL CAPACITORS ARE IN pF/50V UNLESS OTHERWISE NOTED. EX) 030-3pF, 330-33pF, 331-330pF, 333-0.033 $\mu$ F
  - ALL RESISTORS ARE IN OHMS 1/8 WATT UNLESS OTHERWISE NOTED.
  - THE THICK LINES ON PC BOARD ARE THE PRINTING SIDE OF THE PARTS. EX)  $\square$  PRINTING SIDE.
  - "NM" AND "NC" ARE SHORT FOR "NOT MOUNTED" AND "NOT CONNECTED", WHICH MEANS NO PART IS MOUNTED ON WIRING PATTERN OF PCB.
  - CIRCUIT IS SUBJECT TO CHANGE FOR IMPROVEMENT.

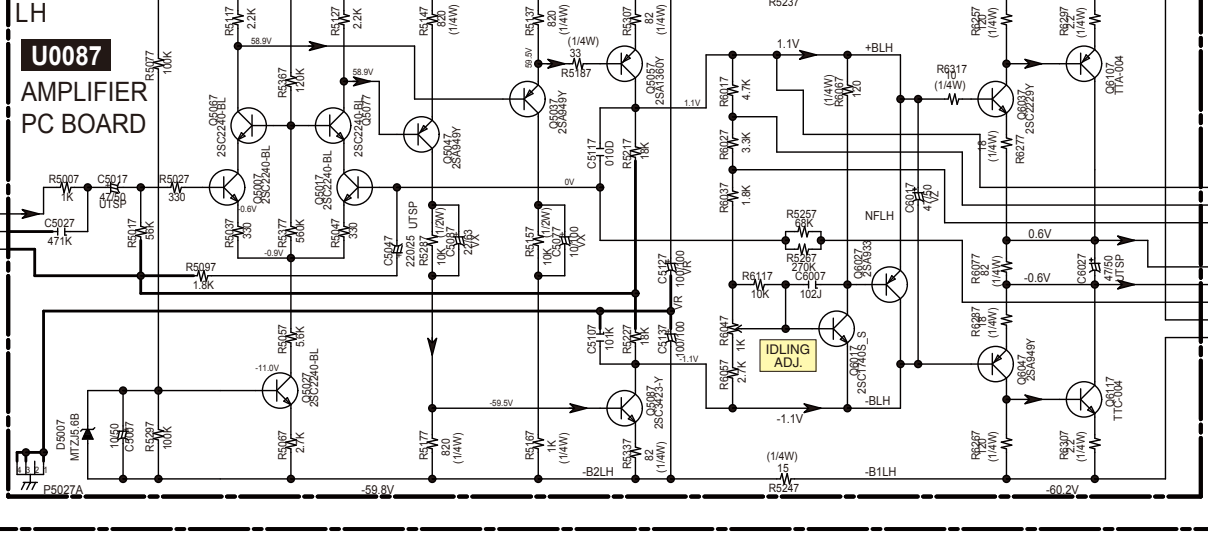
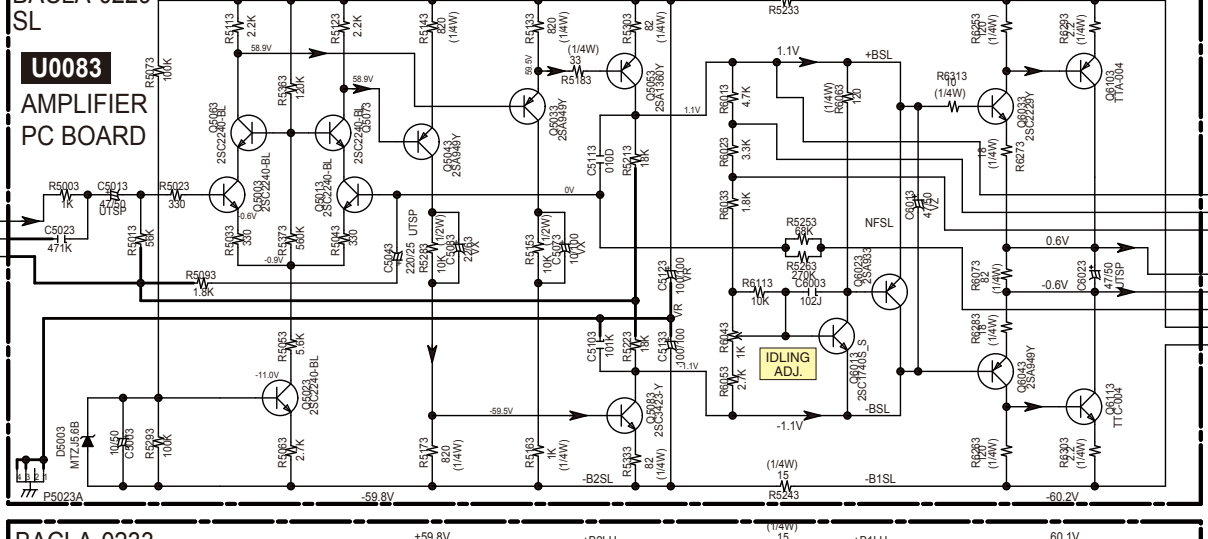
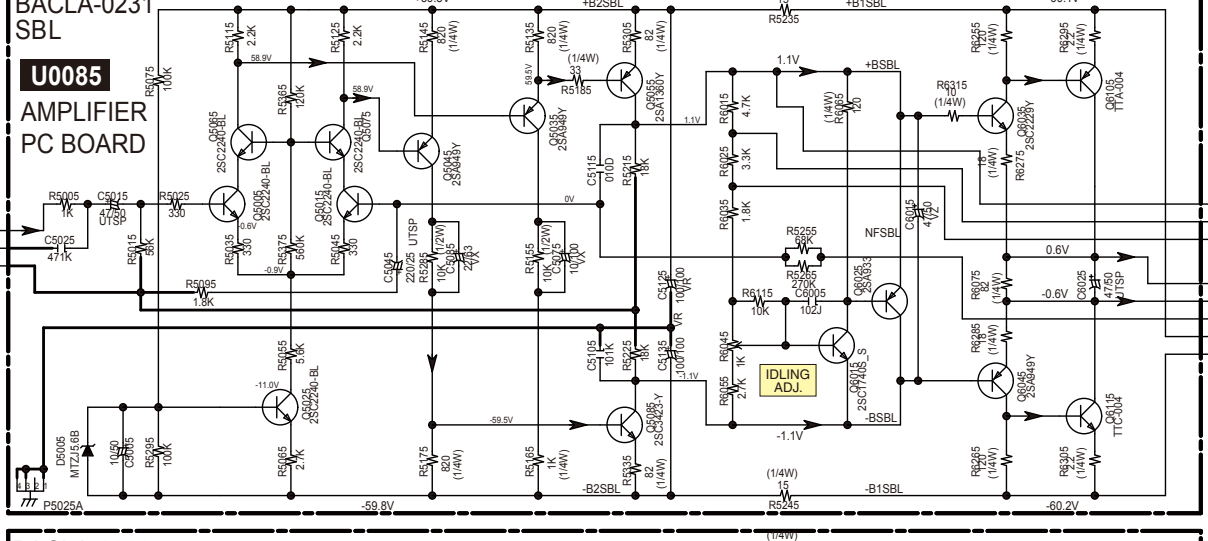
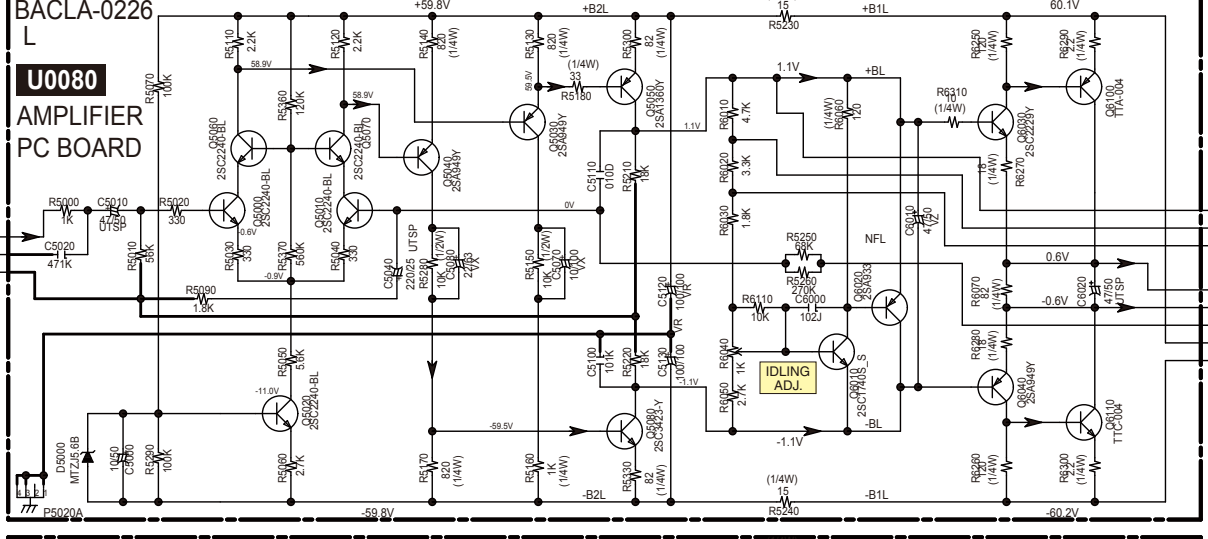
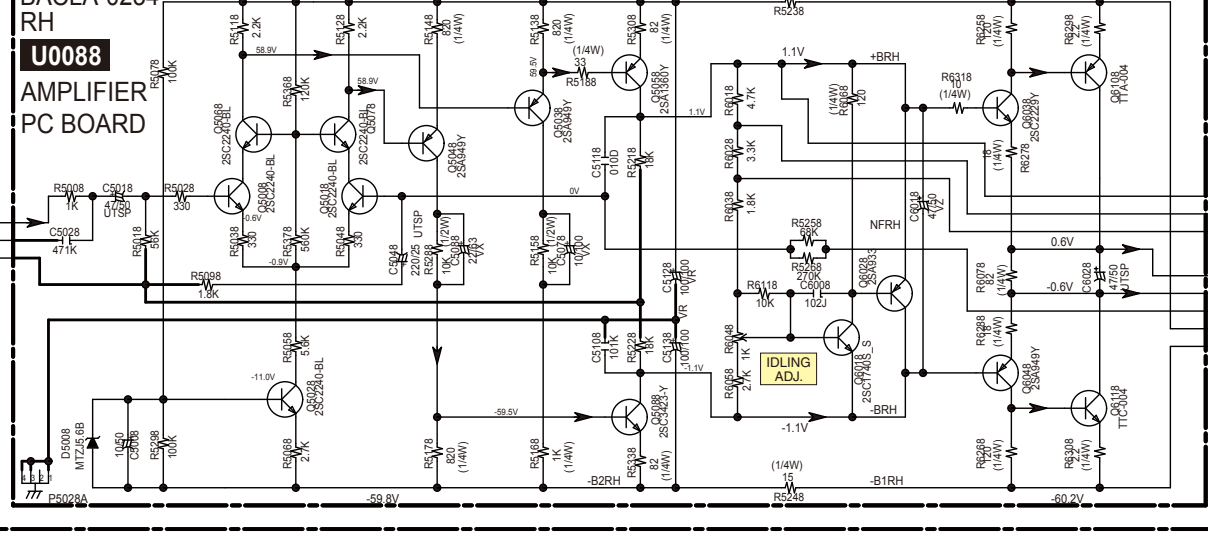
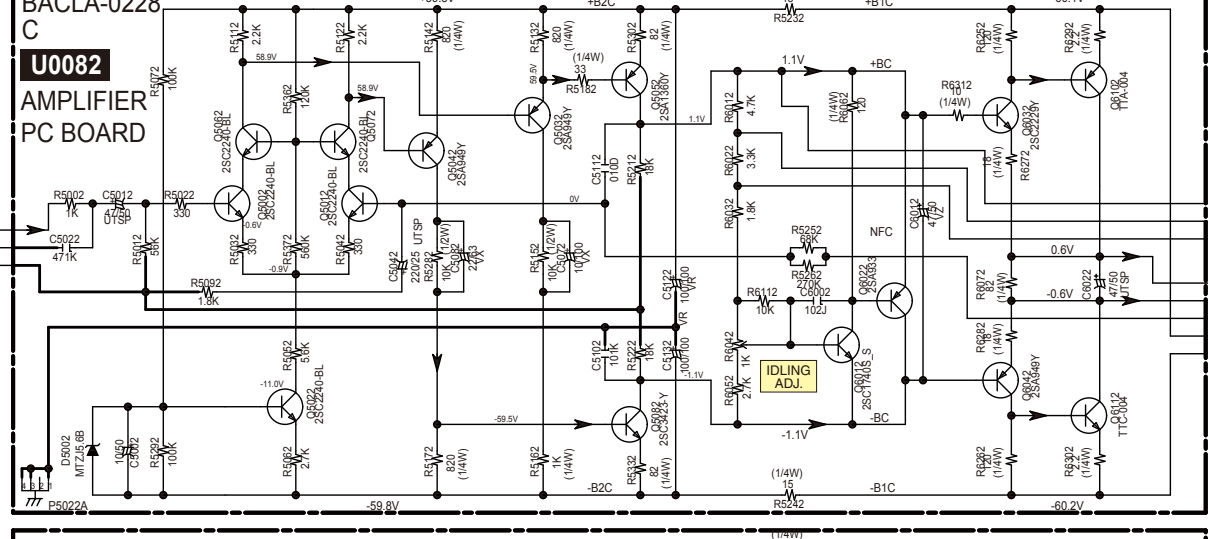
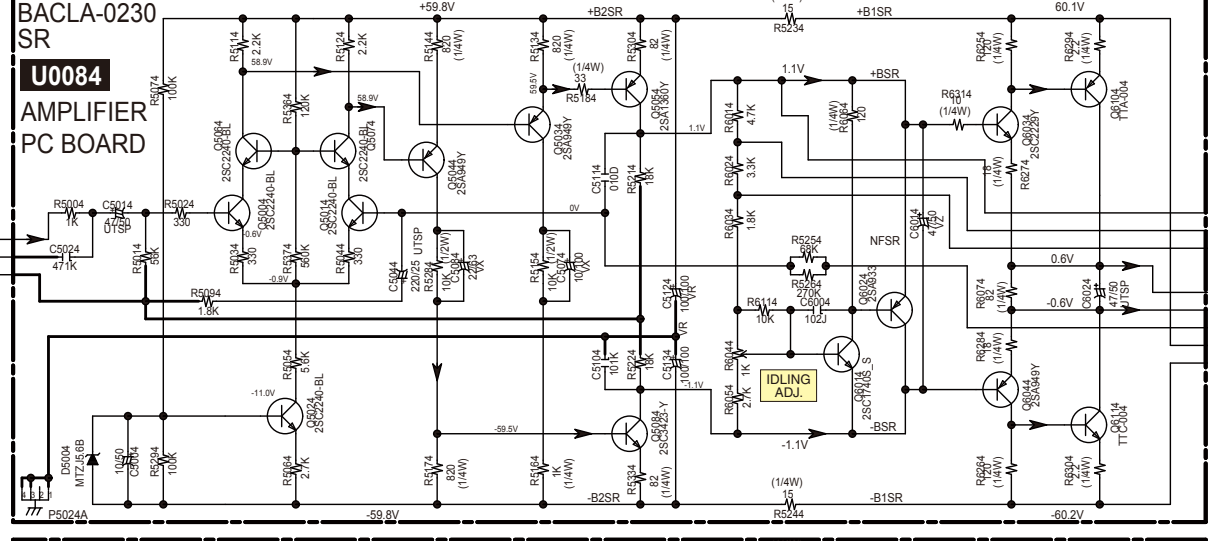
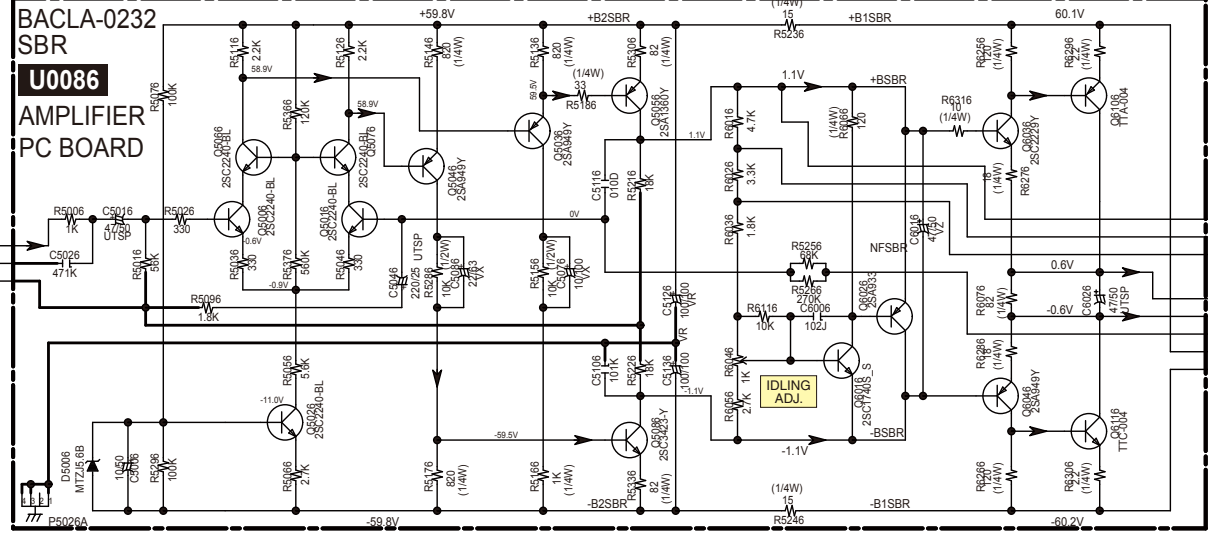
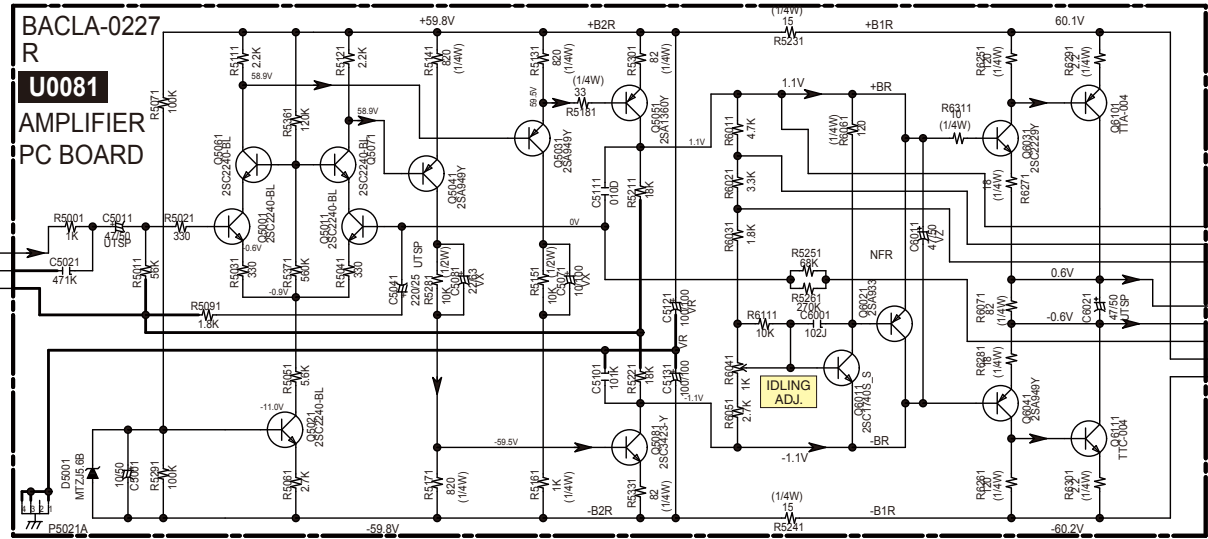

1  
2  
3  
4  
5  
6  
7  
8

A B C D E F G H I J K  
SCHEMATIC DIAGRAMS-2 / PART-7  
AMP2 (FINAL STAGE) SECTION

1  
2  
3  
4  
5  
6  
7  
8

BAAMP-0191

U0020 AMPLIFIER PC BOARD

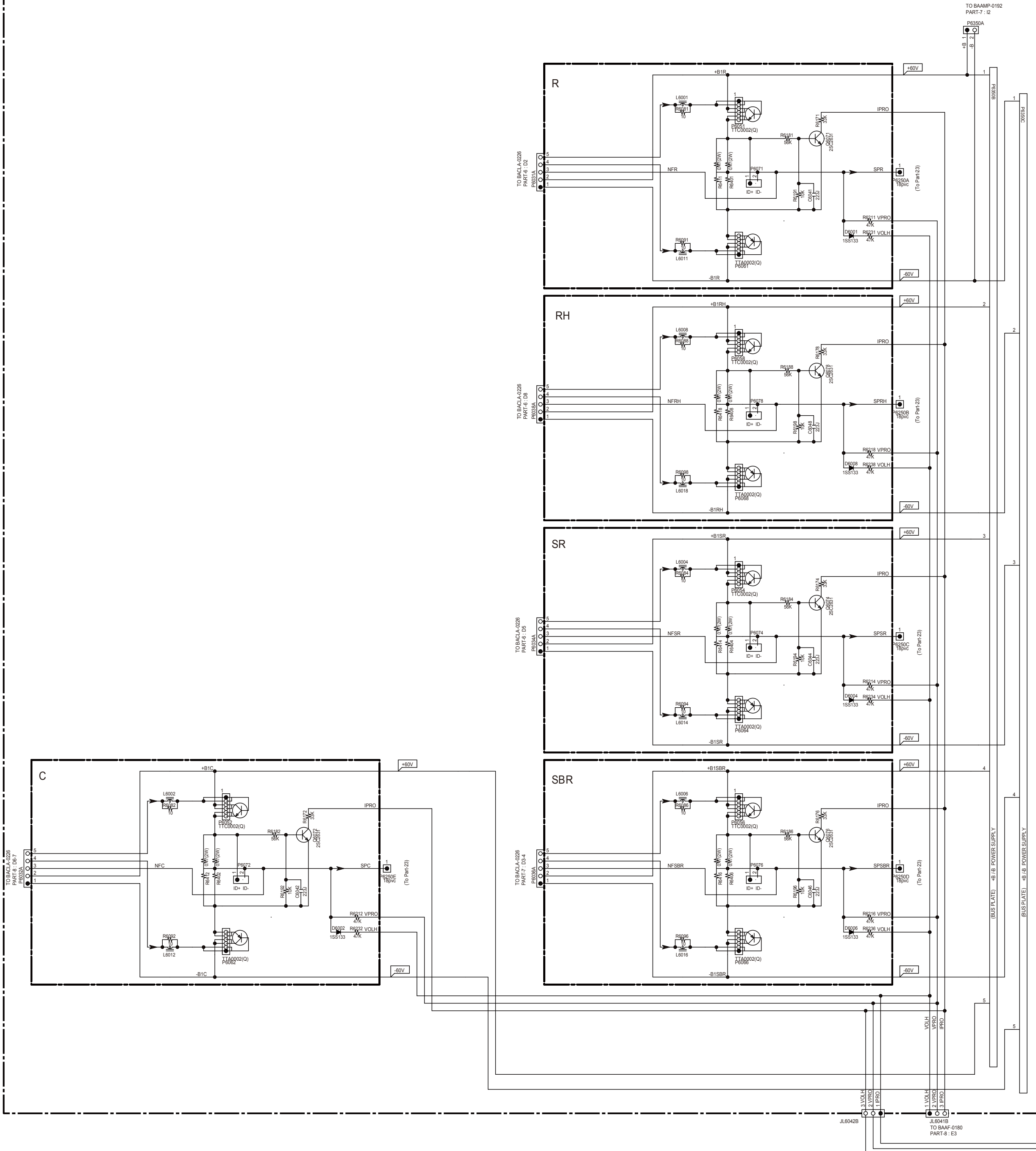

BAAMP-0192

U0021 AMPLIFIER PC BOARD

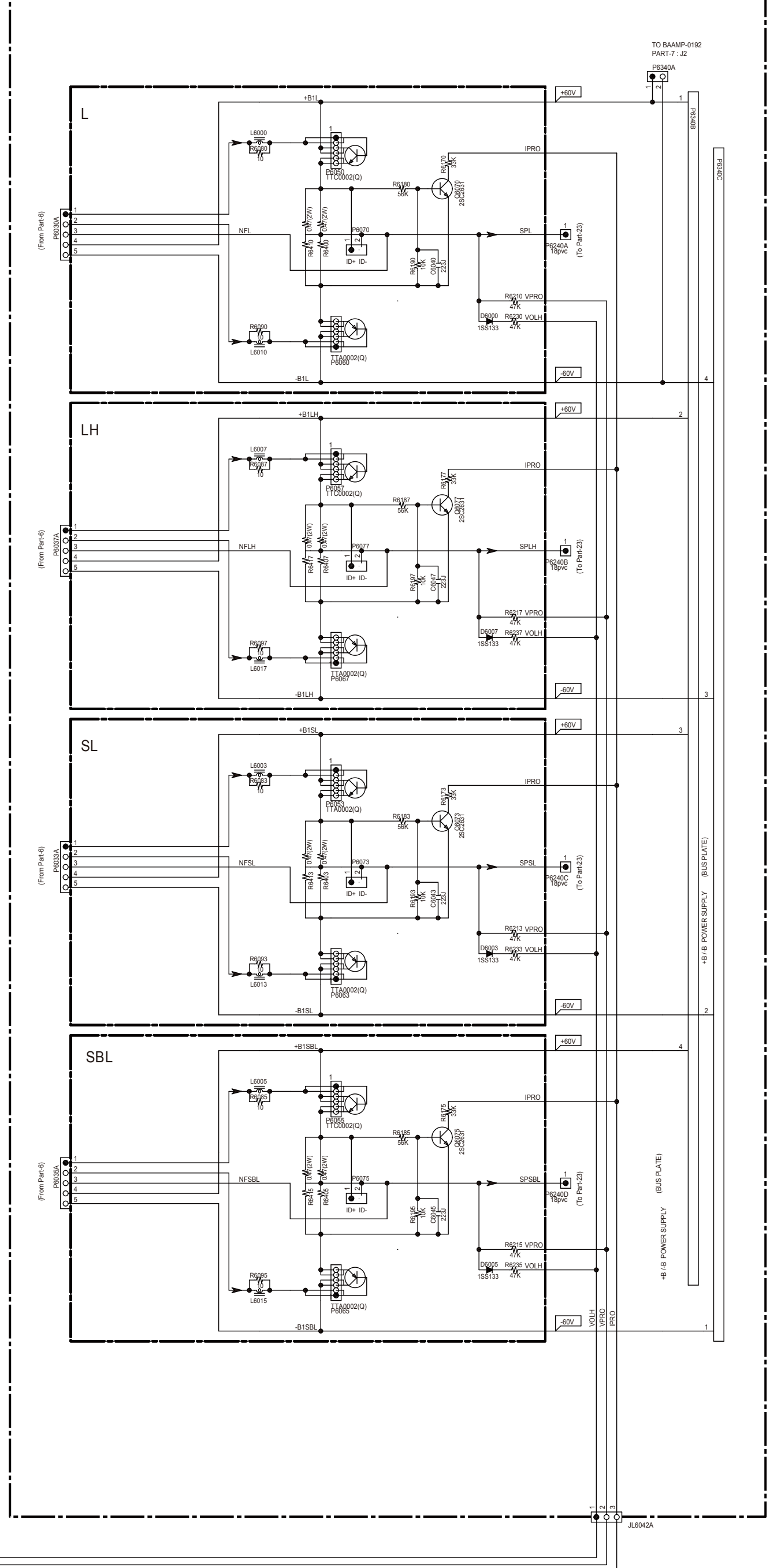

**SCHEMATIC DIAGRAMS-3 / PART-8**  
**AMP3 (POWER SUPPLY, PROTECT ,ETC.) SECTION**

1

2

3

4

5

**BAAF-0180 U0010 POWER SUPPLY PC BOARD**

**U0014 THERMAL SENS PC BOARD**  
**BCETC-0184**

**U0013 THERMAL SENS PC BOARD**  
**BCETC-0183**

**BAPS-0181 U0011 DIODE PC BOARD**

**BAPS-0182 U0012 RELAY PC BOARD**

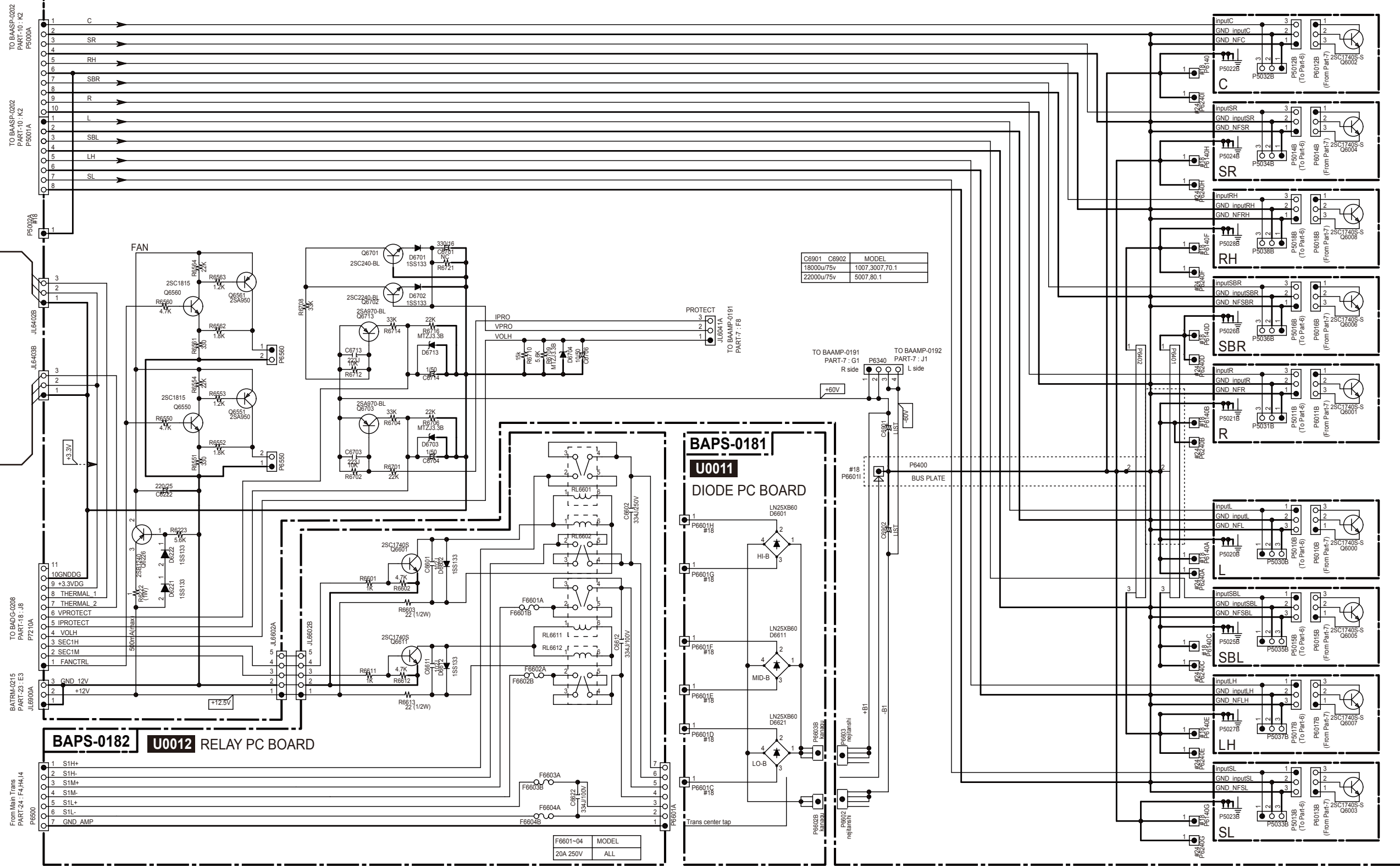

C6901	C6902	MODEL
18000u/75v	1007.3007.70.1	
22000u/75v	5007.80.1	

F6601-04	MODEL
20A 250V	ALL

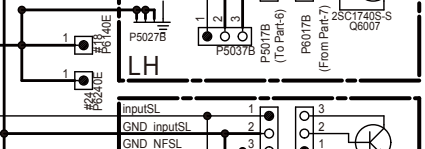
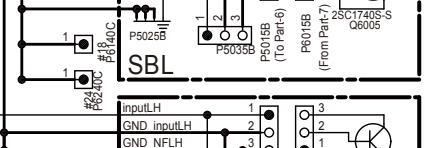
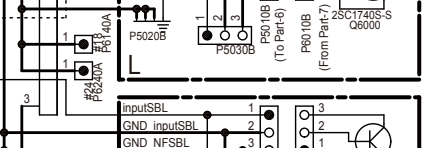
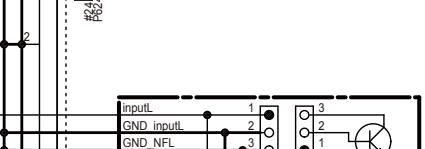
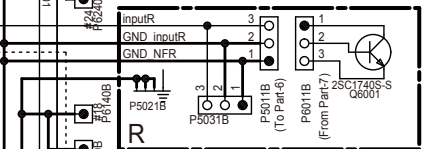
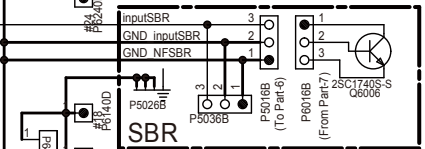
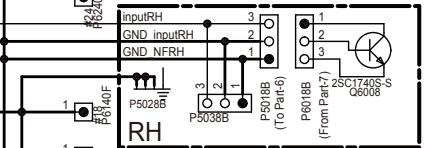
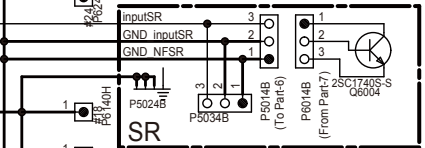
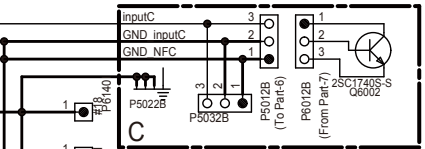

SCHEMATIC DIAGRAMS 4 / PART-9  
ANALOG AUDIO SECTION 1

**BAASP-0202(1/3)**  
**U0030** ANALOG AUDIO PC BOARD

**BAAF-0211** **U0043** PHONO AMP. PC BOARD

**BAAR-0210** **U0042** ZONE2 & ZONE3

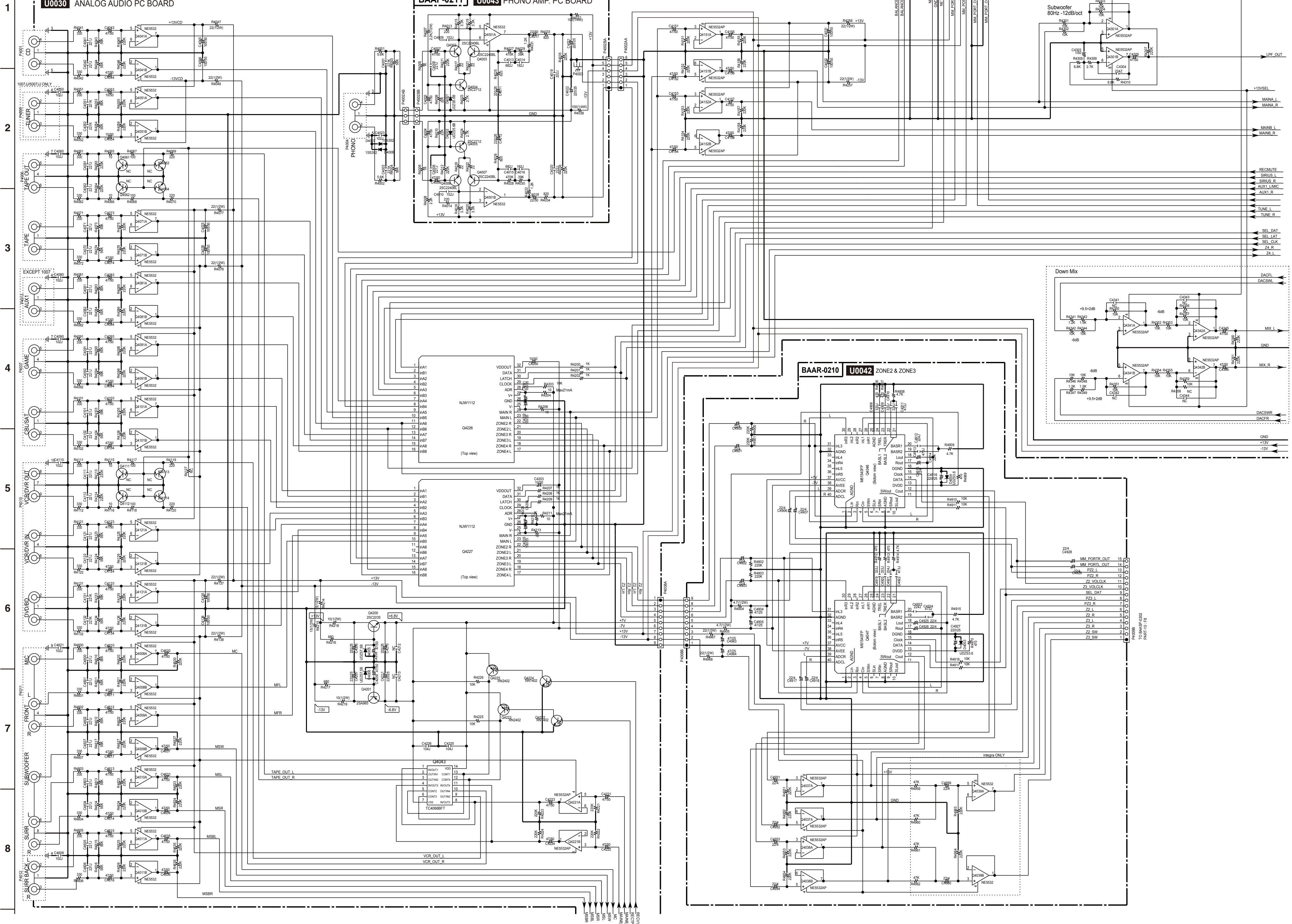

**SCHEMATIC DIAGRAMS-5 / PART-10**  
**ANALOG AUDIO SECTION 2**

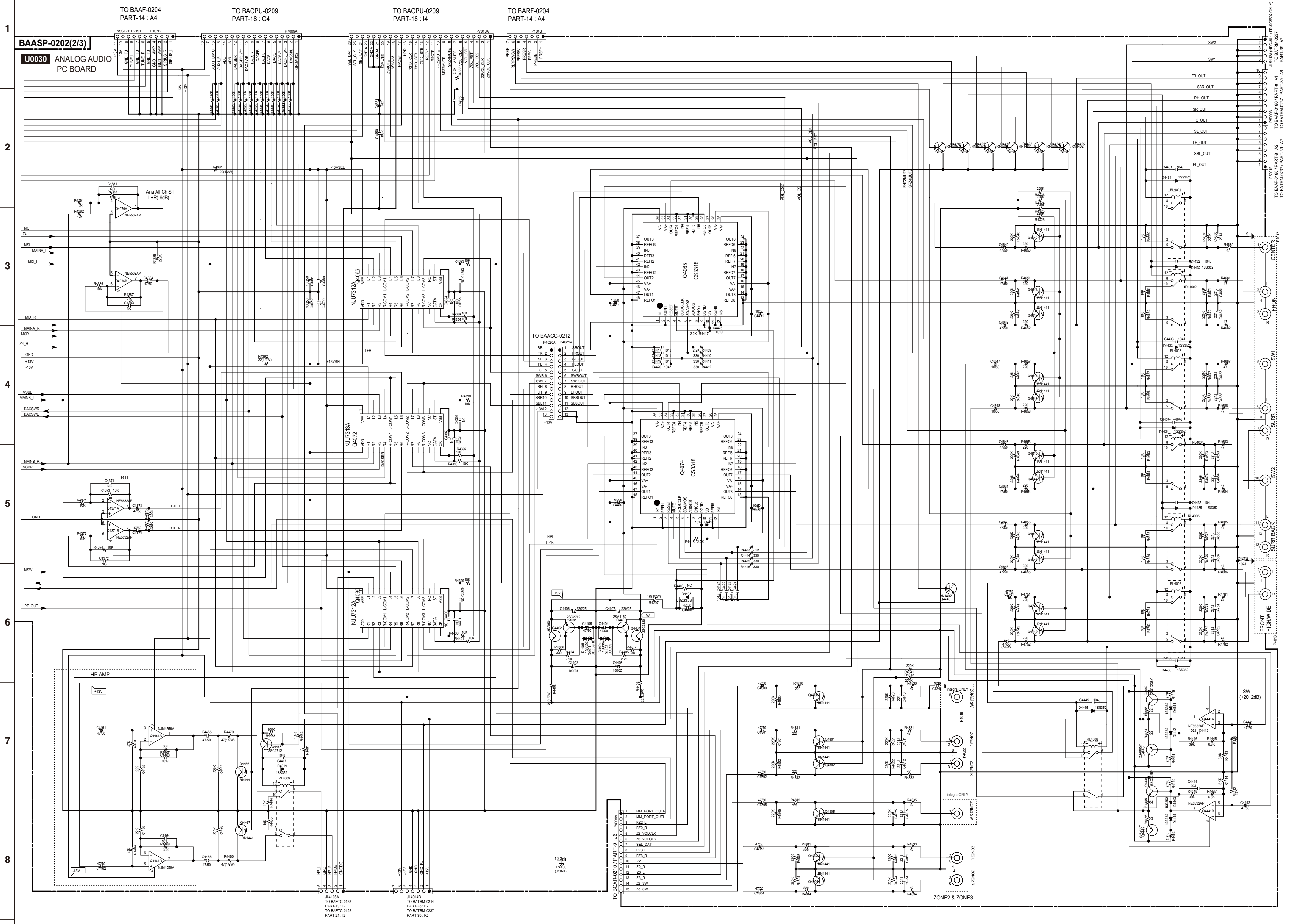



A

B

C

D

SCHEMATIC DIAGRAMS-6 / PART-11  
ANALOG AUDIO SECTION 3

1

BAACC-0212-1

U0044 BUFFER AMPLIFIER PC BOARD

2

3

4

5

BAAASP-0202  
PART-10 : E4

P4020B

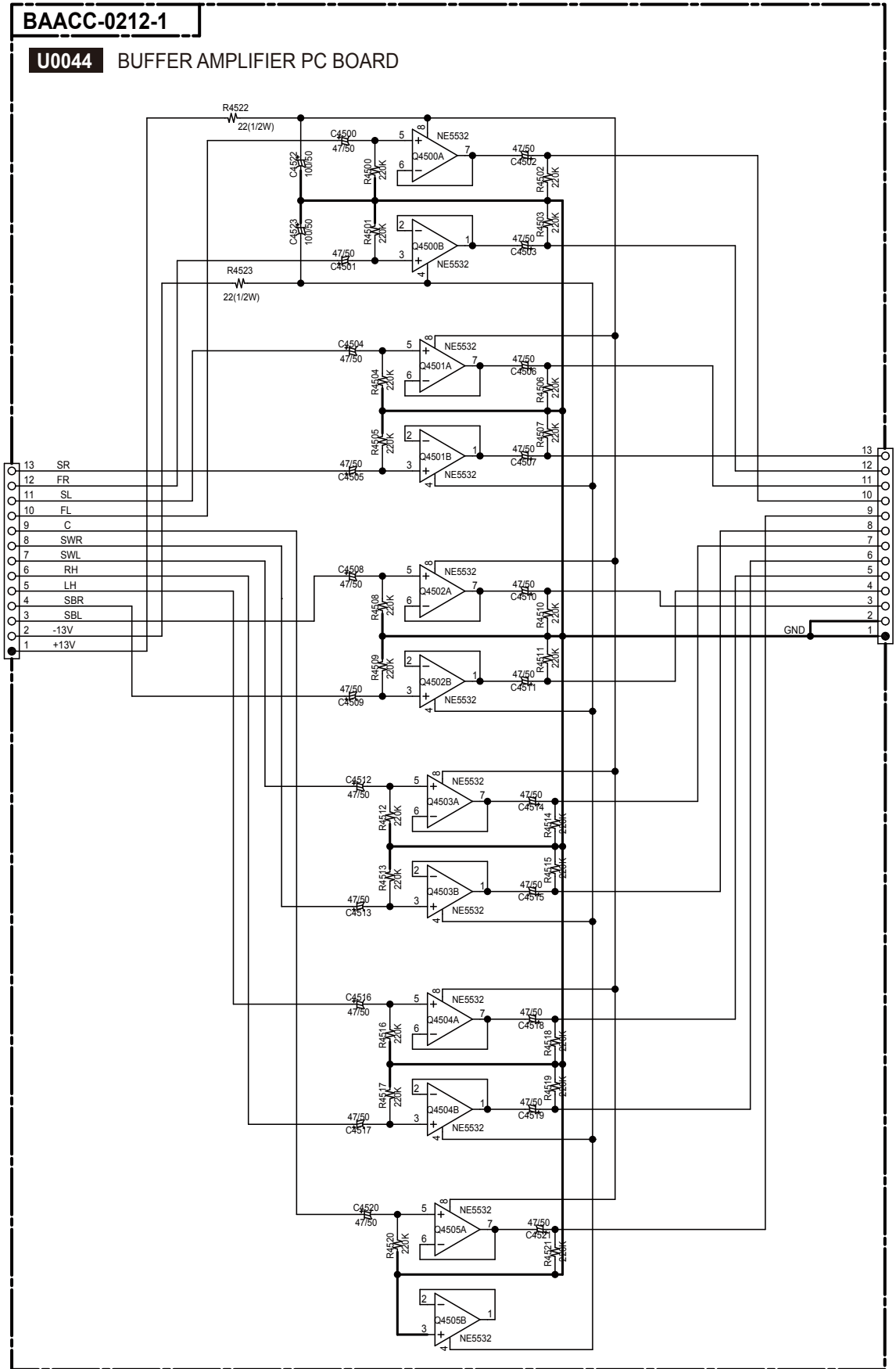

BAAASP-0202  
PART-10 : E4

P4021B

SCHEMATIC DIAGRAMS-7 / PART-12  
ANALOG VIDEO SECTION

1  
2  
3  
4  
5  
6  
7  
8

BAVD-0203-1 U0031 ANALOG VIDEO PC BOARD

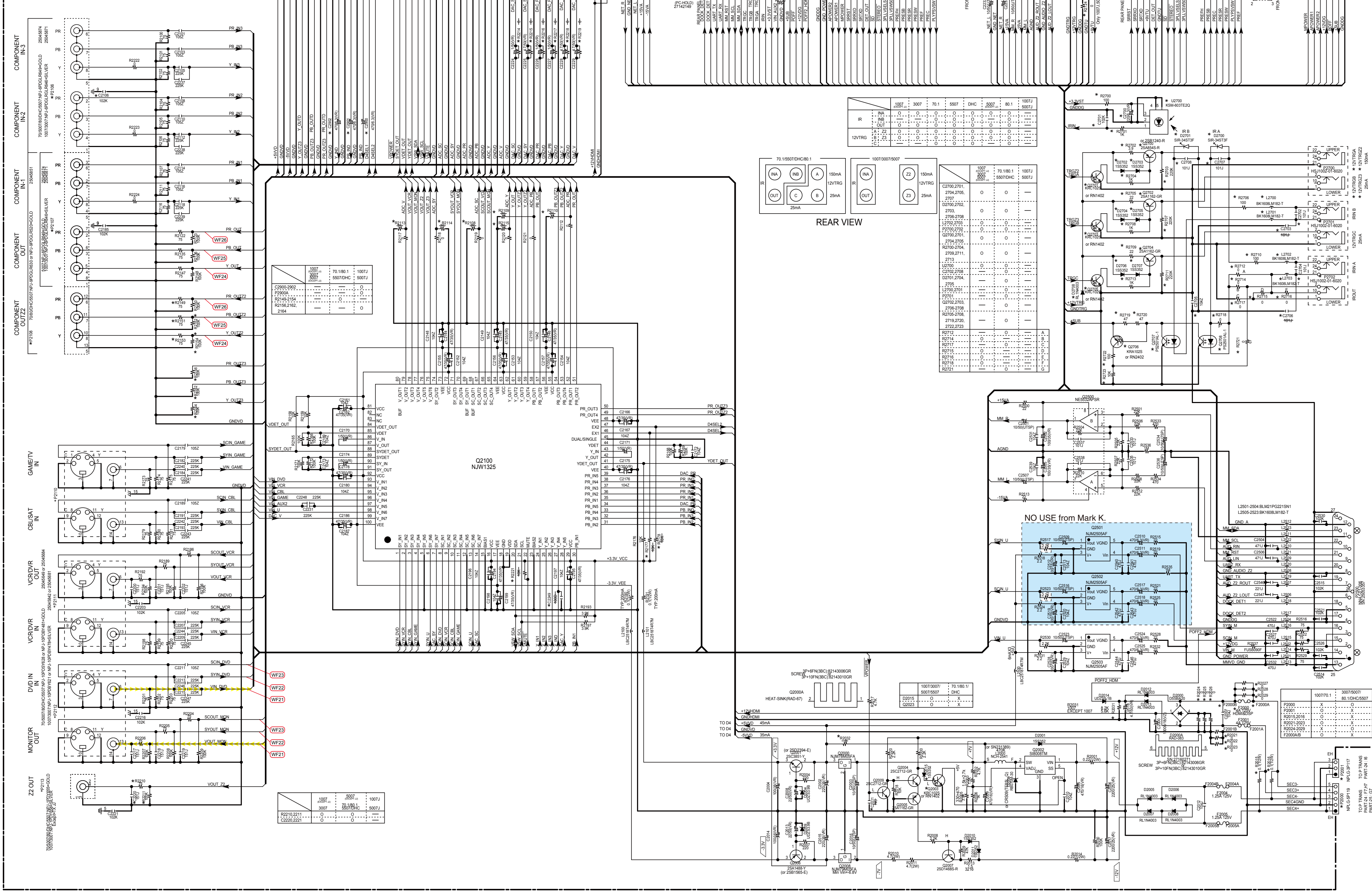

**SCHEMATIC DIAGRAMS-9 / PART-14**  
**SIRIUS, ANALOG TUNER SECTION**

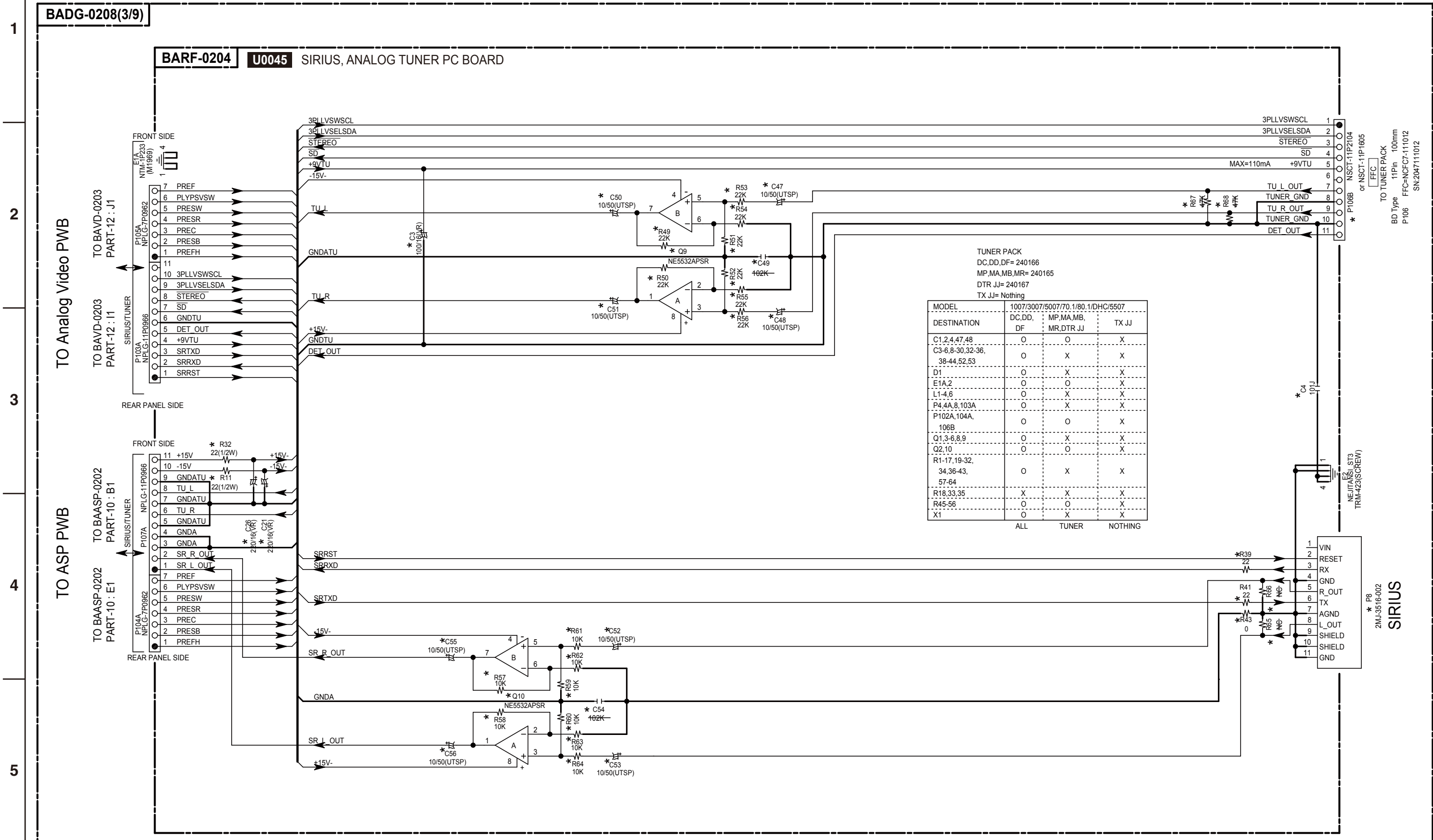

**SCHEMATIC DIAGRAMS-11 / PART-16**  
**DG AUDIO IN SECTION**

**BADG-0208(8/9)**

**BAETC-0246 U0046** DG AUDIO IN PC BOARD

TO BAHDM-0132/0157  
PART-29 : A1

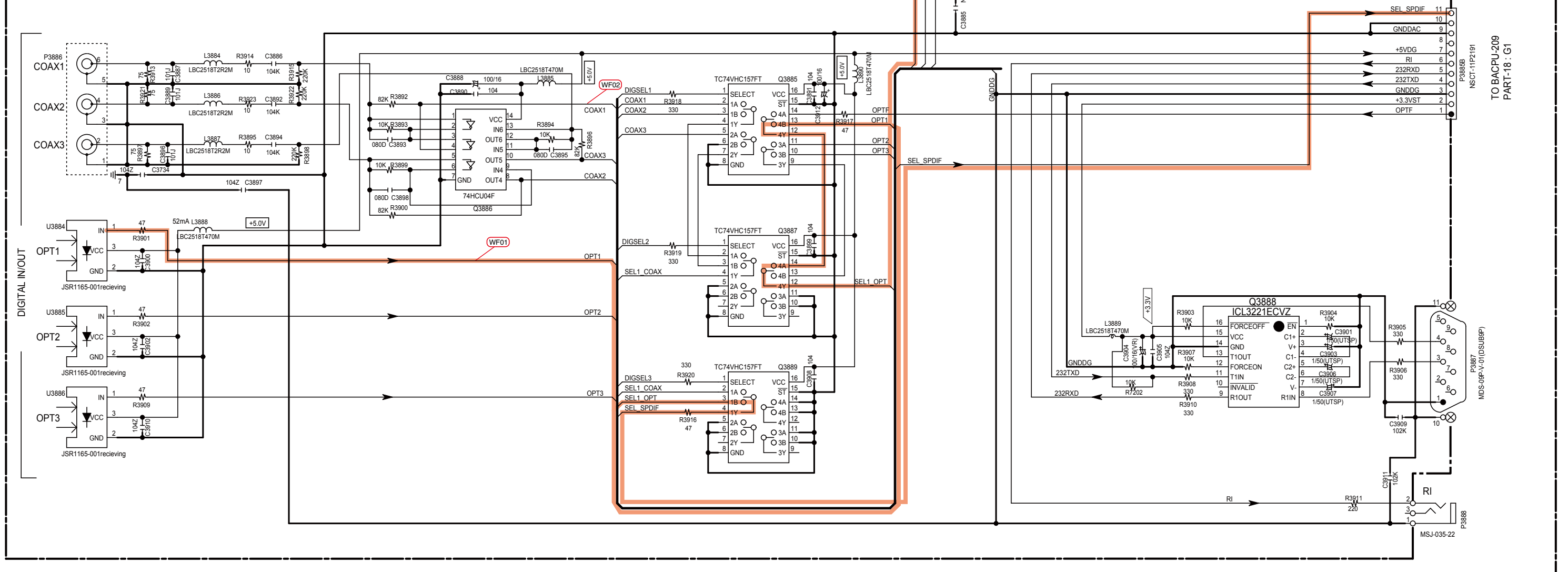
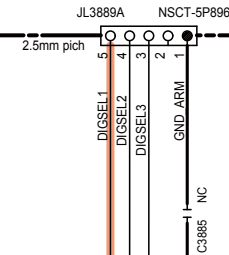

TO BACPU-209  
PART-18 : G1

P3887  
MDS-08P-V-01(DSUB9P)

P3888  
MSJ-035-22

SCHEMATIC DIAGRAMS-12 / PART-17  
CODEC, DAC AND VLSC SECTION

BADG-0208-1 U0040 CODEC, DAC AND VLSC PC BOARD

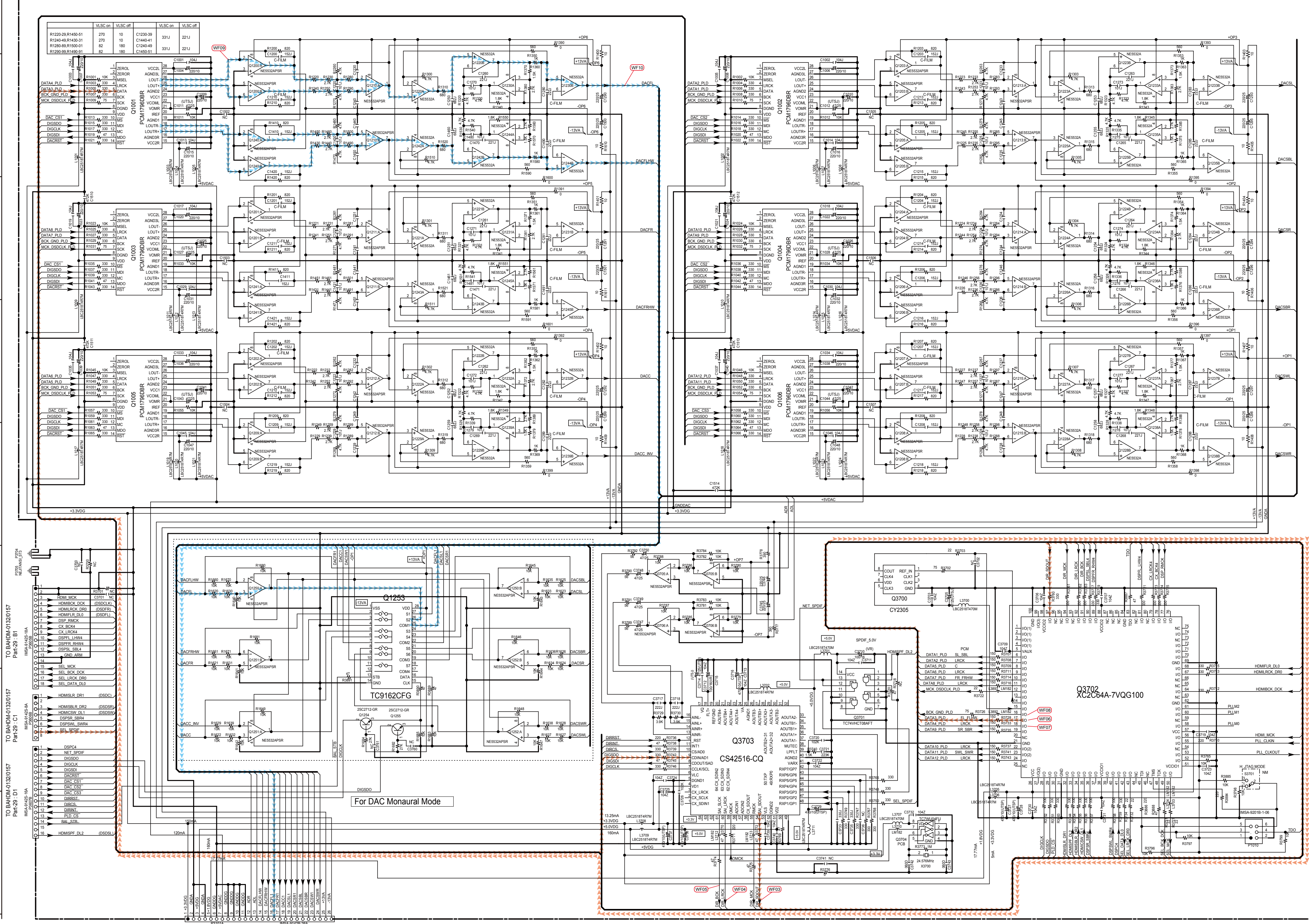

SCHEMATIC DIAGRAMS-13 / PART-18  
MAIN MICROPROCESSOR SECTION

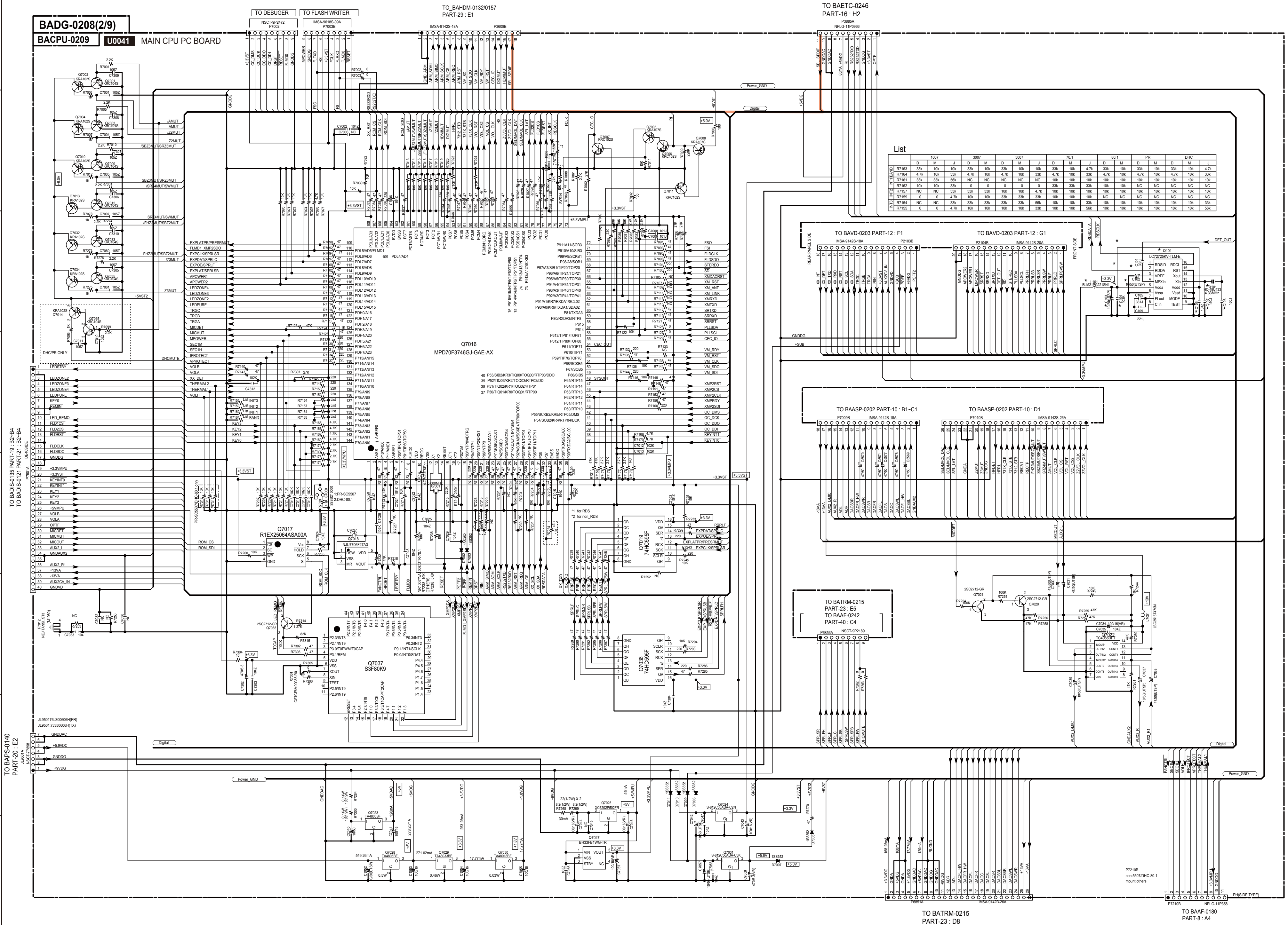

List

Part No.	QTY	1007	3007	5007	70.1	80.1	PR	DHC
R7183	33k	10k	10k	33k	10k	10k	33k	10k
R7184	4.7k	10k	33k	4.7k	10k	4.7k	10k	33k
R7185	10k	10k	33k	10k	10k	10k	10k	10k
R7186	0	0	4.7k	10k	10k	33k	33k	10k
R7187	0	0	4.7k	10k	10k	10k	10k	10k
R7188	0	0	4.7k	10k	10k	10k	10k	10k
R7189	0	0	4.7k	10k	10k	10k	10k	10k
R7190	0	0	4.7k	10k	10k	10k	10k	10k
R7191	0	0	4.7k	10k	10k	10k	10k	10k
R7192	0	0	4.7k	10k	10k	10k	10k	10k

TO BADIS-0135 PART-19: B2-B4  
TO BADIS-0121 PART-21: B2-B4

TO BAPS-0140 PART-20: E2

TO BAED-0203 PART-12: F1

TO BAED-0203 PART-12: G1

TO BAASP-0202 PART-10: B1-C1

TO BAASP-0202 PART-10: D1

TO BATRM-0215 PART-23: E5

TO BAAF-0242 PART-40: C4

TO BATRM-0215 PART-23: D8

TO BAAF-0180 PART-8: A4

SCHEMATIC DIAGRAMS-14 / PART-19  
DISPLAY SECTION

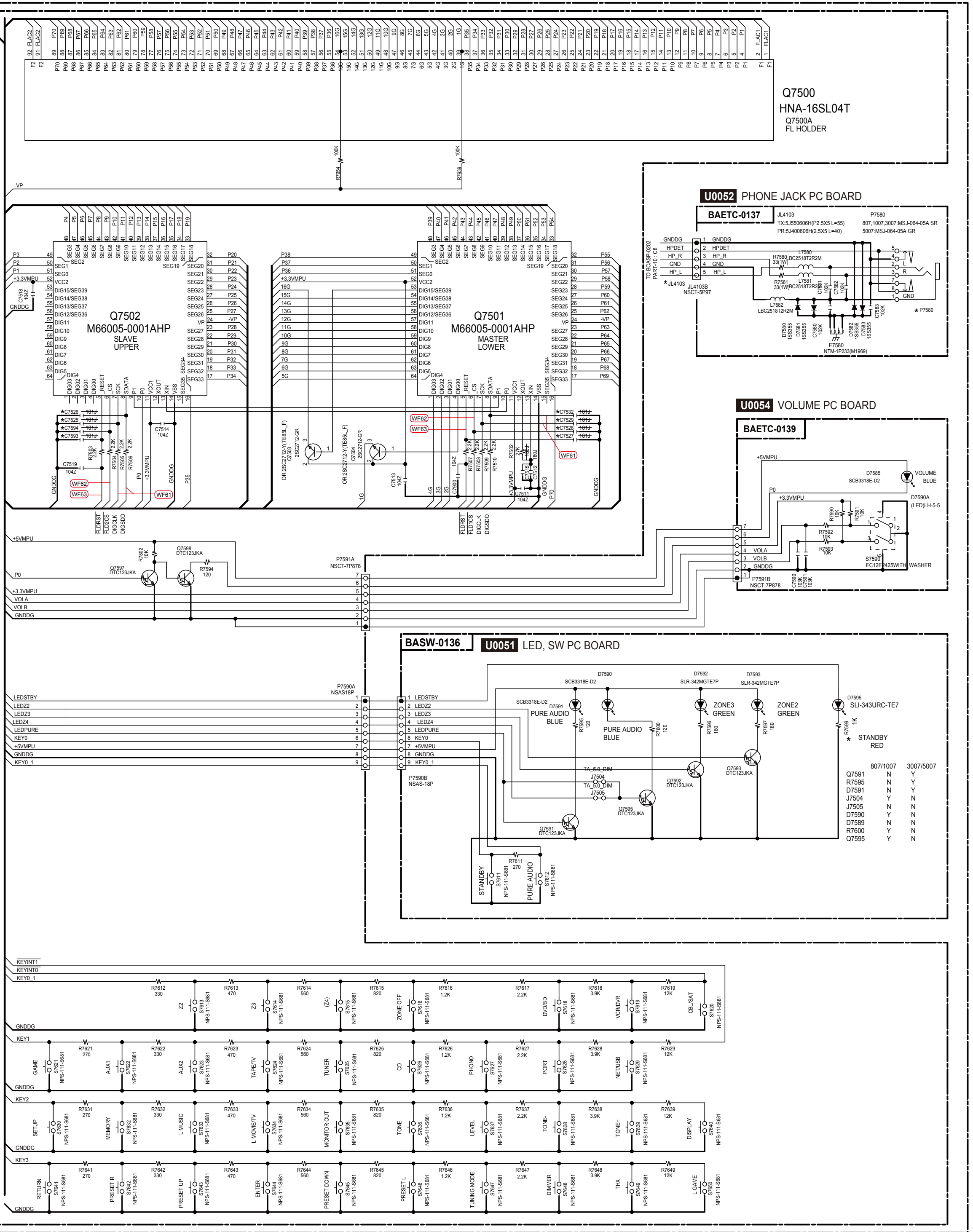
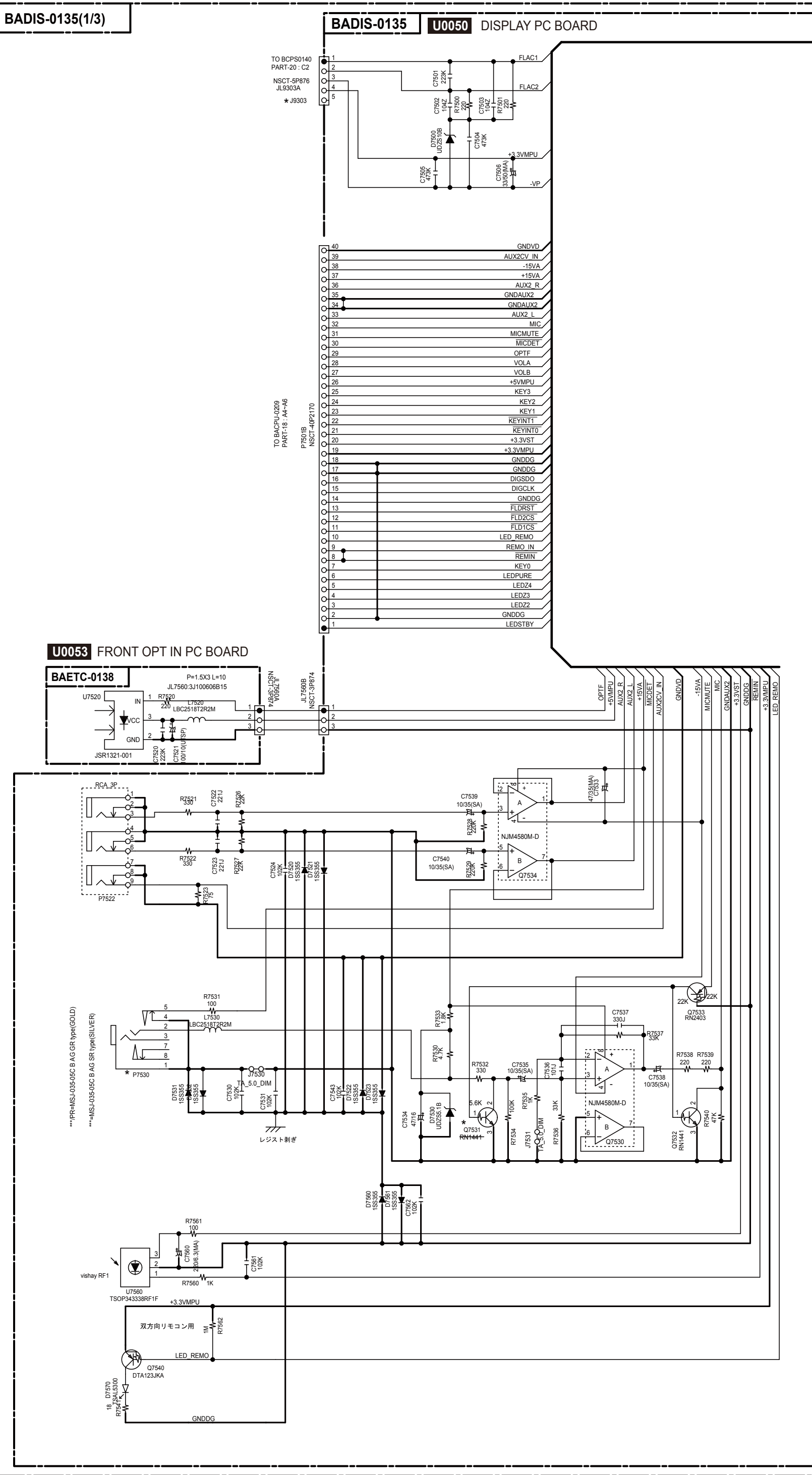

**SCHEMATIC DIAGRAMS-15 / PART-20**  
**DG POWER SUPPLY SECTION**

1

2

3

4

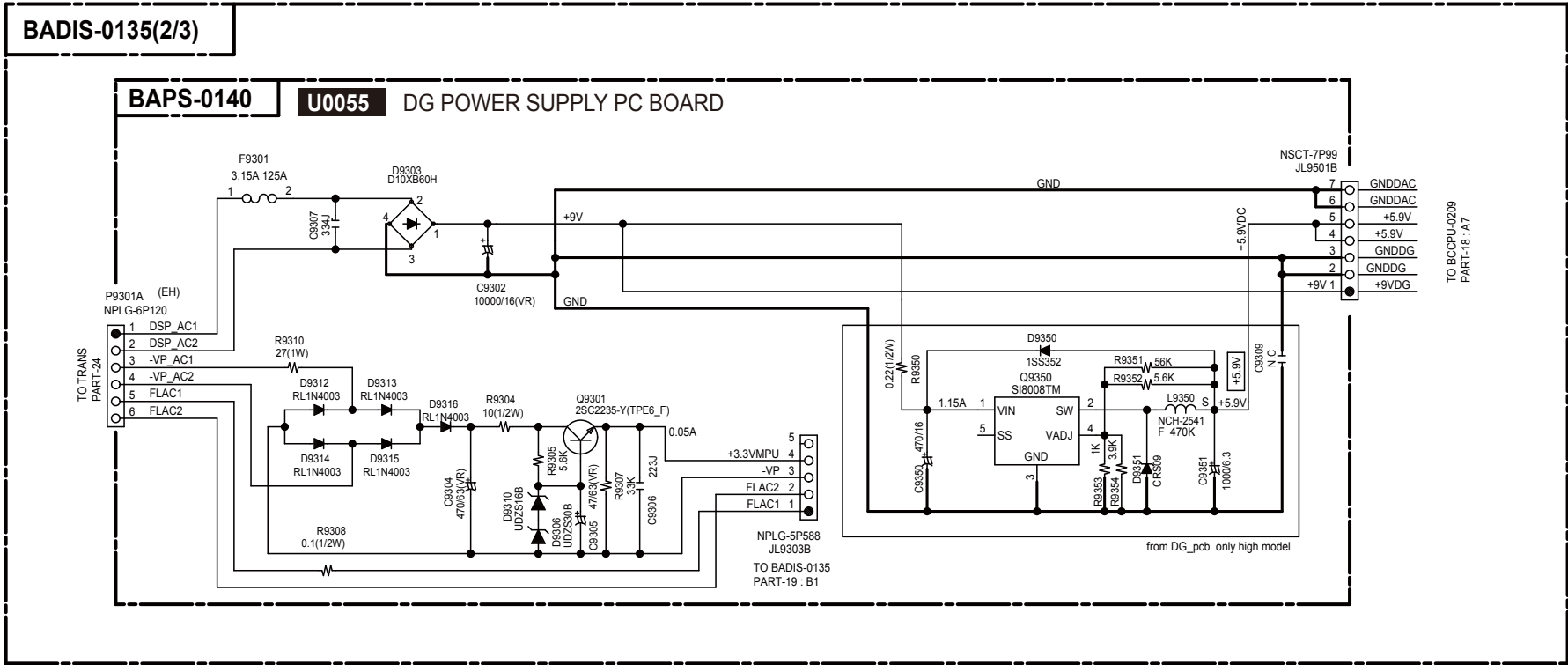



SCHEMATIC DIAGRAMS-18 / PART-23  
POWER SUPPLY AND SPEAKER TERMINAL SECTION

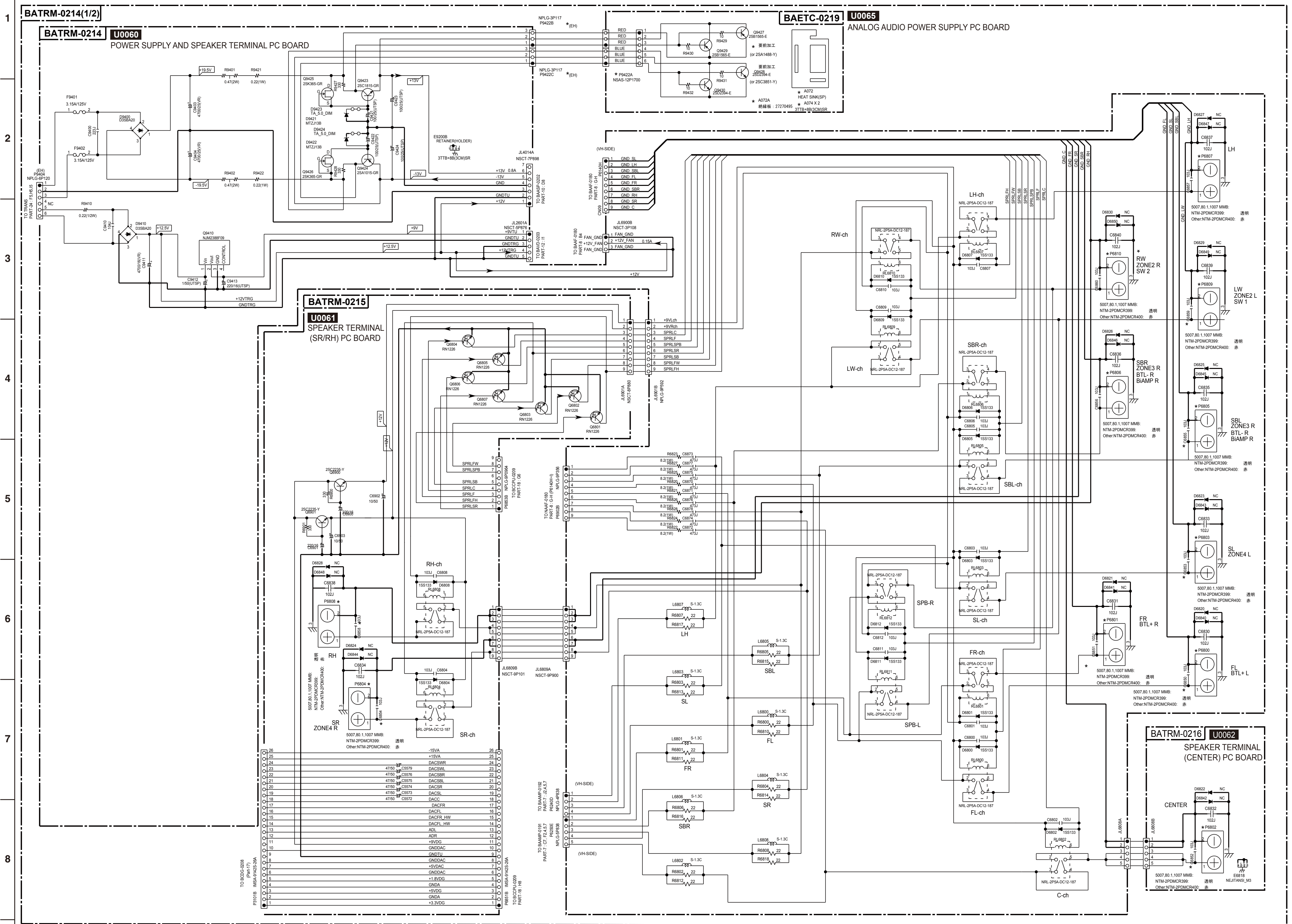

SCHEMATIC DIAGRAMS-19 / PART-24  
PRIMARY POWER SUPPLY (AMP) SECTION

1  
2  
3  
4  
5  
6  
7  
8

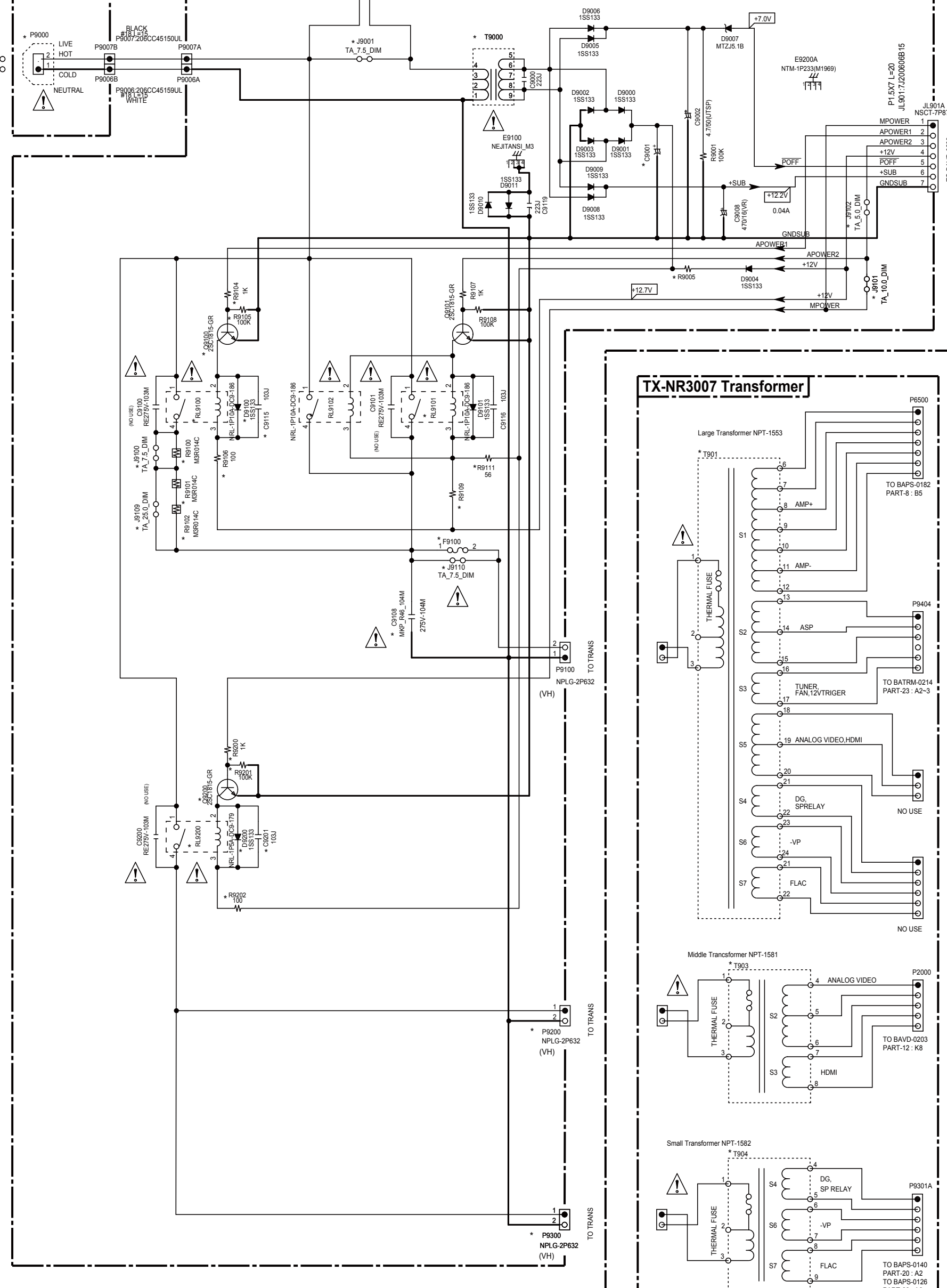
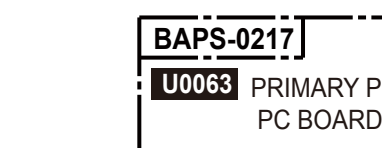
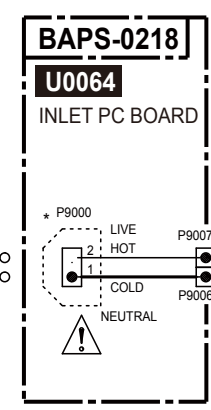
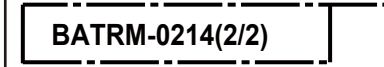
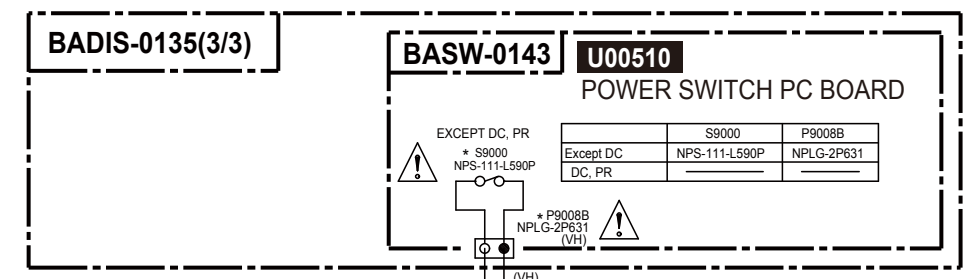

Component	1007/70.1	3007	5007/80.1
C9108	Except Type	Except Type	Except Type
C9109	D.J.	○	○
C9201	○	○	○
J9100	D.J.	○	○
J9200	○	○	○
J9300	○	○	○
J9400	DC, Integr.	DC, Integr.	DC, Integr.
J9500	DC	DC	DC
J9600	○	○	○
J9700	○	○	○
J9800	○	○	○
J9900	○	○	○
J9901	○	○	○
J9902	○	○	○
J9903	○	○	○
J9904	○	○	○
J9905	○	○	○
J9906	○	○	○
J9907	○	○	○
J9908	○	○	○
J9909	○	○	○
J9910	○	○	○
J9911	○	○	○
J9912	○	○	○
J9913	○	○	○
J9914	○	○	○
J9915	○	○	○
J9916	○	○	○
J9917	○	○	○
J9918	○	○	○
J9919	○	○	○
J9920	○	○	○
J9921	○	○	○
J9922	○	○	○
J9923	○	○	○
J9924	○	○	○
J9925	○	○	○
J9926	○	○	○
J9927	○	○	○
J9928	○	○	○
J9929	○	○	○
J9930	○	○	○

T9000	D.J. NPT-152JQ
OHTERS	NPT-152GQ
C9001	D.220025V
D.220025V	OHTERS:220016V
F9100	D.12A-UL-ST6
M.6.3A-SE-TL250V	12A/125V
J.15A-T-ST6N1	6.3A/250V
	15A/125V

- 印は火災、感電の危険に關する部品の為、必ず指定部品を使用する。
- 電圧表示は無極性時に測定した直流電圧を示す。
- (単位 V、入力抵抗 100kΩ 以上の電圧計)
- 記入なき電解コンデンサの単位は  $\mu F/VV$  である。
- 例) 030-33F 330-330F 331-330F 333-0.033  $\mu F$
- 本配線図は基本配線図につき性能改善等により予告なく変更する事がある。
- THE COMPONENTS IDENTIFIED BY MARK ARE CRITICAL FOR SAFETY. REPLACE ONLY WITH PART NUMBER SPECIFIED.
- VOLTAGE (MEASURED WITH VOLTMETER) IS DC VOLTAGE (NO INPUT SIGNAL)
- ELECTROLYTIC CAPACITORS ARE IN  $\mu F/VV$
- ALL CAPACITORS ARE IN  $\mu F/500V$  UNLESS OTHERWISE NOTED
- EX) 030-33F 330-330F 331-330F 333-0.033  $\mu F$
- CIRCUIT IS SUBJECT TO CHANGE FOR IMPROVEMENT.

**CAUTION**  
FOR CONTINUED PROTECTION AGAINST FIRE HAZARD, REPLACE ONLY WITH FUSE OF SAME TYPE AND RATING INDICATED.

**ATTENTION**  
AFIN D'ASSURER UNE PROTECTION PERMANENTE CONTRE LES RISQUES D'INCENDIE, REMPLACER UNIQUEMENT PAR UN FUSIBLE DE MEME TYPE ET CALIBRATION COMME INDIQUE.

THIS SYMBOL LOCATED NEAR THE FUSE INDICATES THAT THE FUSE USED IS SLOW OPERATING TYPE FOR CONTINUED PROTECTION AGAINST FIRE FUSE HAZARD. REPLACE WITH SAME TYPE FUSE. FOR FUSE RATING REFER TO THE MAKING ADJACENT TO THE SYMBOL.

CE SYMBOLE INDIQUE QUE LE FUSIBLE UTILISE EST A LENT. E POUR UNE PROTECTION PERMANENTE CONTRE LES RISQUES D'INCENDIE. REMPLACER PAR UN FUSIBLE DE MEME TYPE. CE DERNIER EST INDIQUE LA QU LE PRESENT SYMBOLE EST APPOSE.

TX-NR3007 Transformer

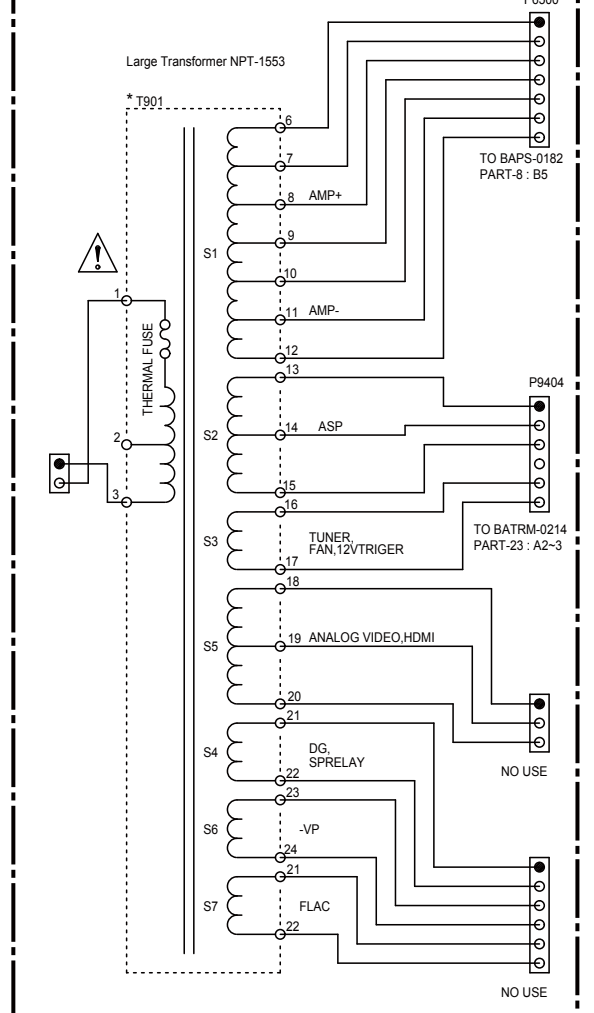

TX-NR5007/NA5007, DTR-80.1 Transformer

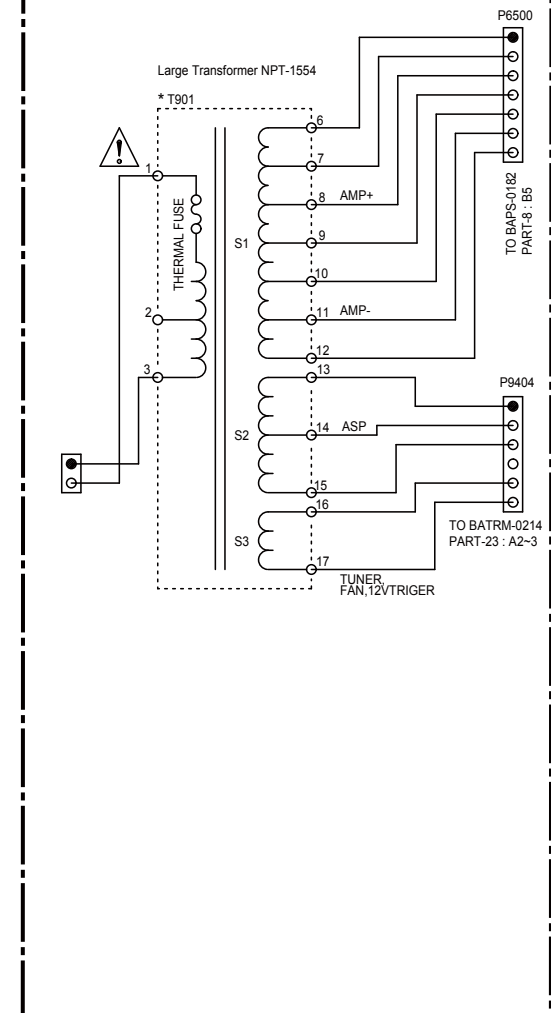

TX-NR1007/NA1007, DTR-70.1 Transformer

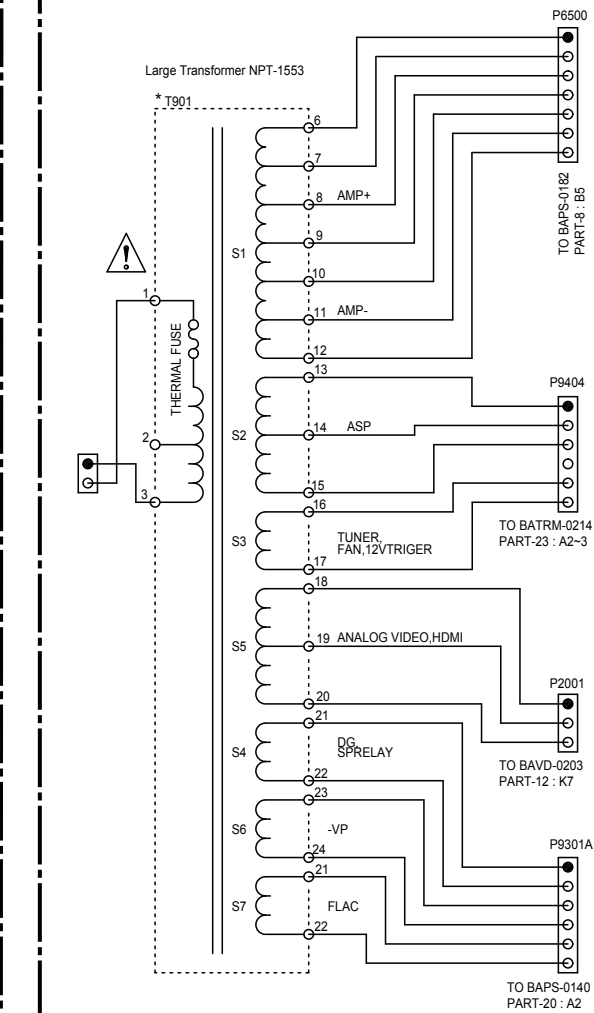

Middle Transformer NPT-1581

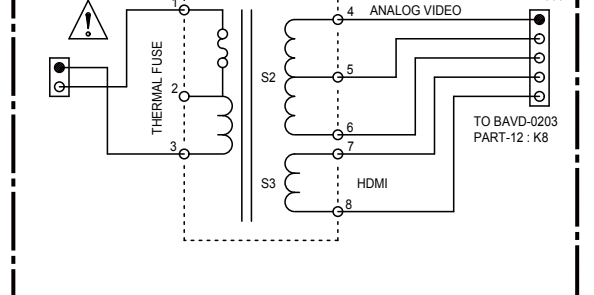

Middle Transformer NPT-1581

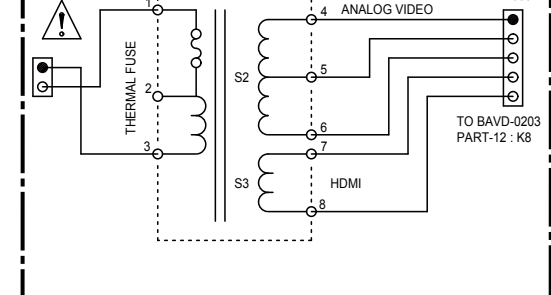

Small Transformer NPT-1582

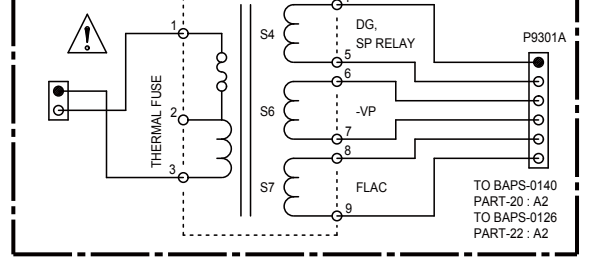

Small Transformer NPT-1582

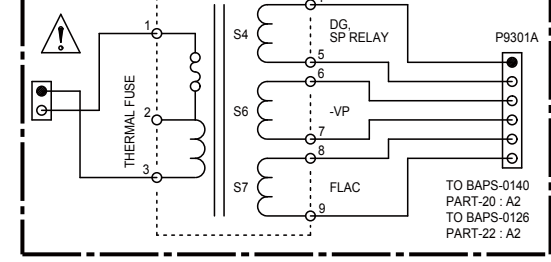

SCHEMATIC DIAGRAMS-21 / PART-26  
NET / USB / ZONE2 SECTION

BAHDM-0132/0157 (1/8)

U007  
HDMI PC BOARD

SPI0 & control signals  
to 2nd DSP  
from HDMI Block  
from DIR Block

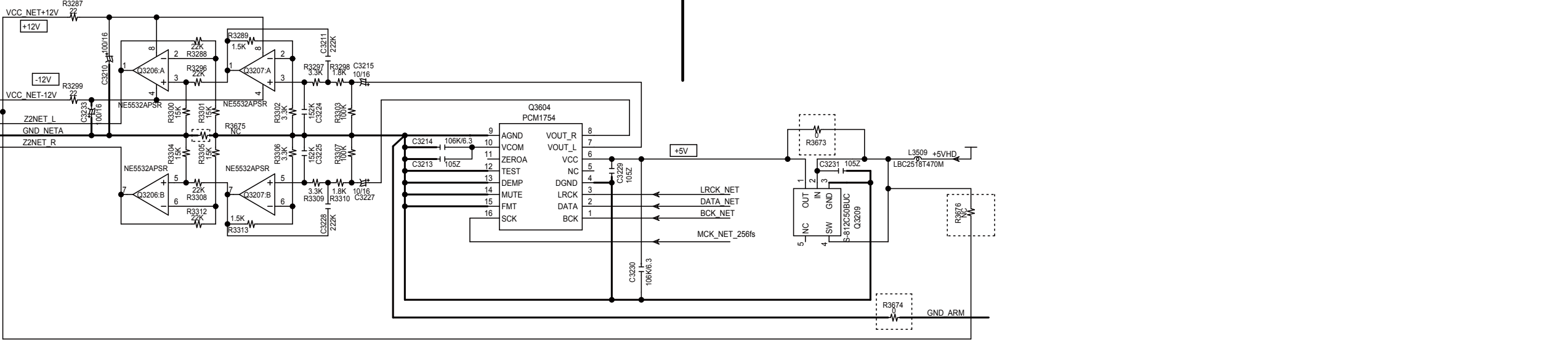
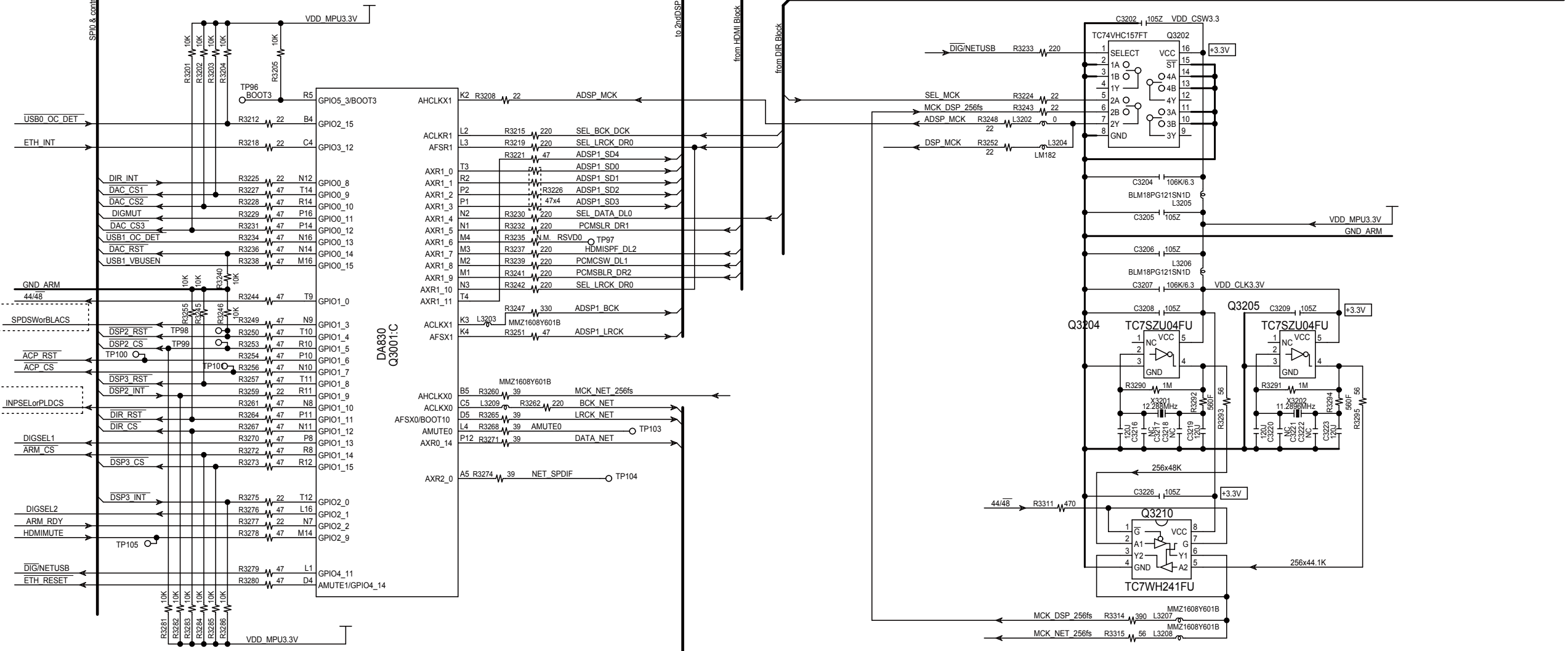

1  
2  
3  
4  
5

A B C D E F G H

SCHEMATIC DIAGRAMS-22 / PART-27  
NET / USB / POWER SECTION

BAHDM-0132/0157 (2/8)

U007  
HDMI PC BOARD

R3115 or R3116	BOOT2
R3111 or R3112	BOOT5
R3109 or R3110	BOOT6
R3107 or R3108	BOOT7

Boot Opt.			
NAND	UART1	SPI0	
BOOT7	L	H	L
BOOT1	L	H	L
BOOT0	H	L	L
BOOT3	H	L	H
BOOT2	H	H	H

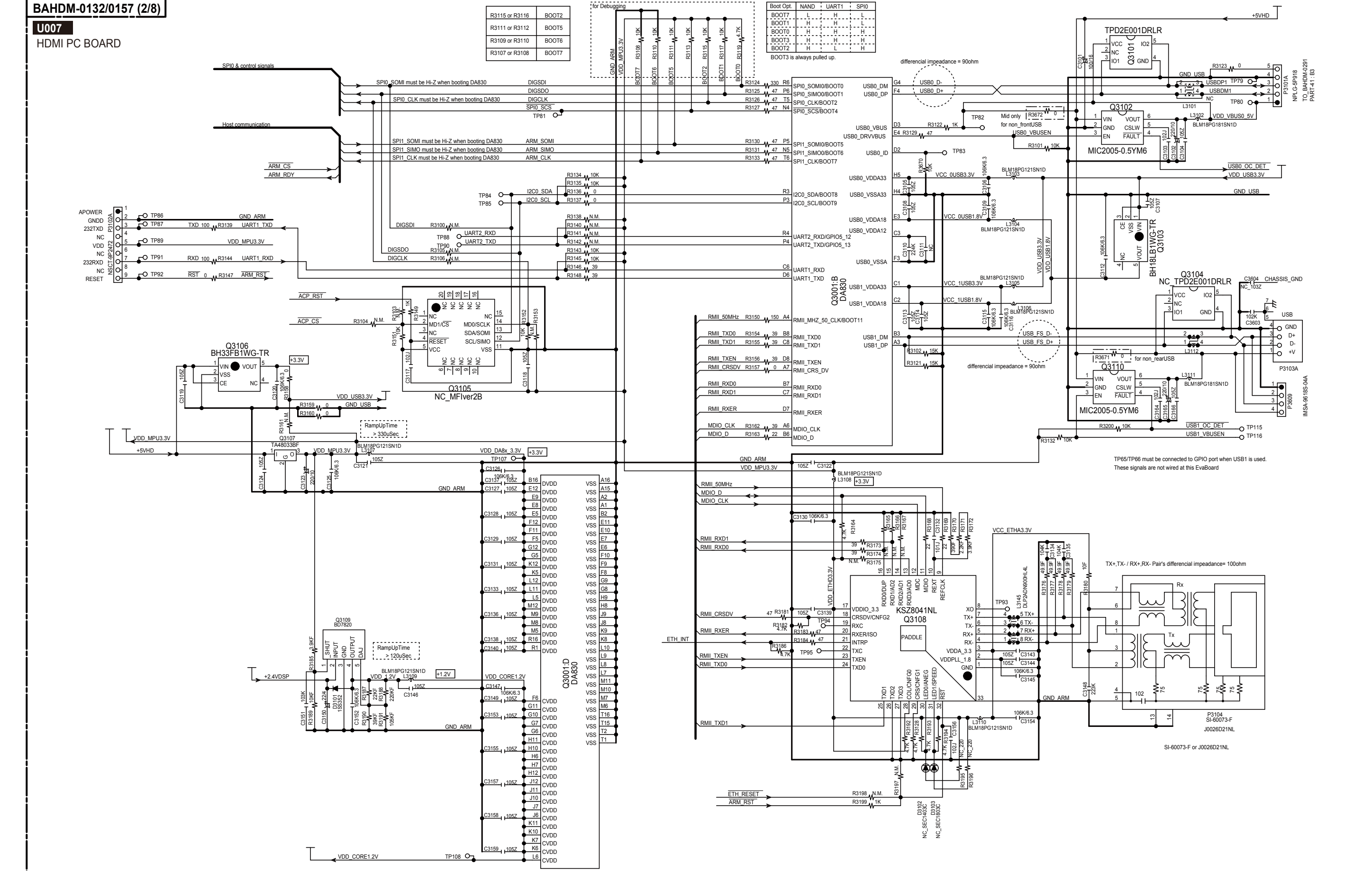

1

2

3

4

5

SCHEMATIC DIAGRAMS-23 / PART-28  
DSP MEMORY SECTION

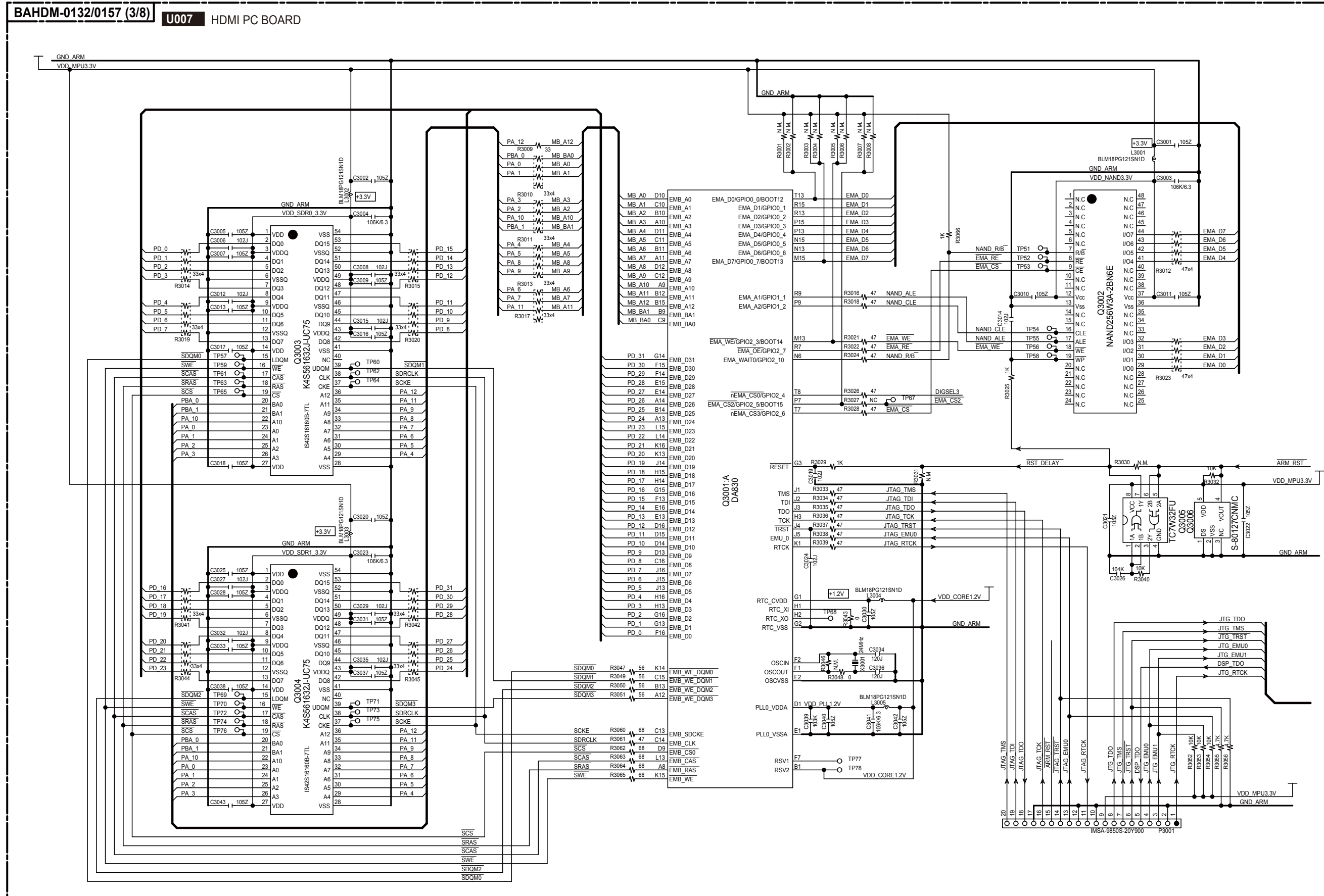

1

2

3

4

5

A

B

C

D

E

**SCHEMATIC DIAGRAMS-24 / PART-29**  
**DSP CONNECTOR SECTION**

1

**BAHDM-0132/0157 (4/8)**

**U007**

HDMI PC BOARD

TO\_BAETC-0246  
PART-16 : E2  
NSCT-5P97  
JL3889B

TO\_BADG-0208  
PART-17 : A6  
IMSA-9142B-18A  
P3605A

TO\_BADG-0208  
PART-17 : A7  
IMSA-9142B-8A  
P3606A

TO\_BADG-0208  
PART-17 : A8  
IMSA-9142B-16A  
P3607A

TO\_BACPU-0209  
PART-18 : D1  
P3608A  
IMSA-9142B-18A

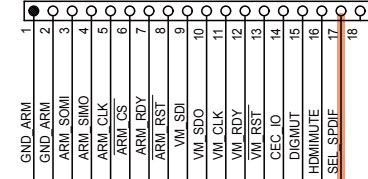
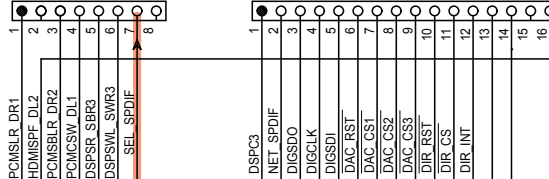
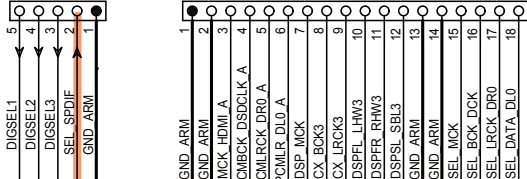

2

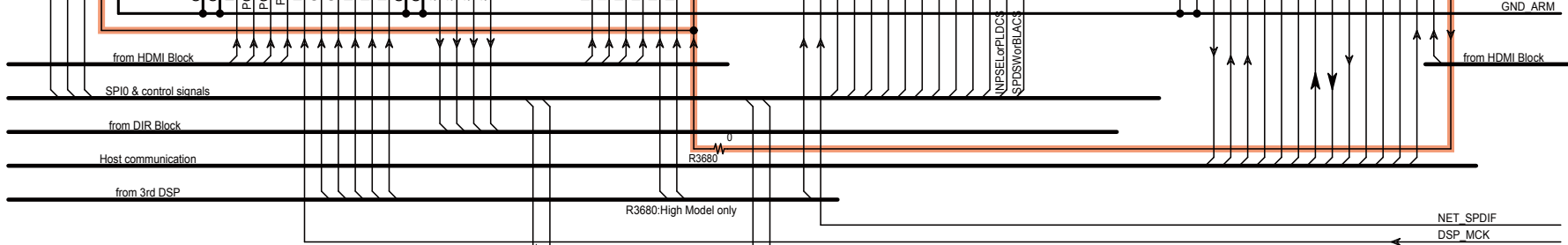

3

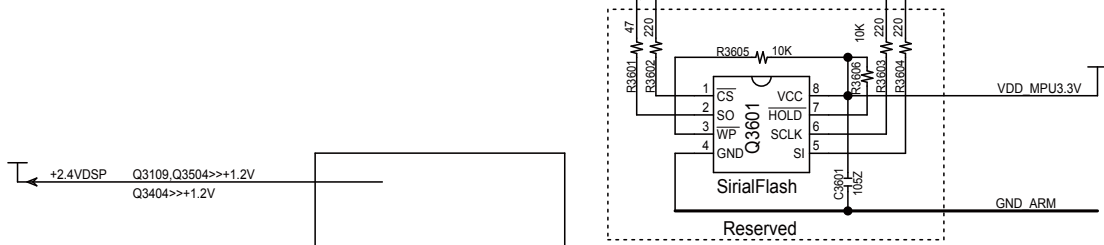

4

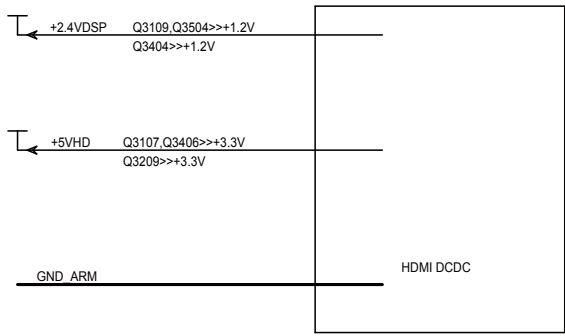

SCHEMATIC DIAGRAMS-25 / PART-30  
2ND DSP SECTION

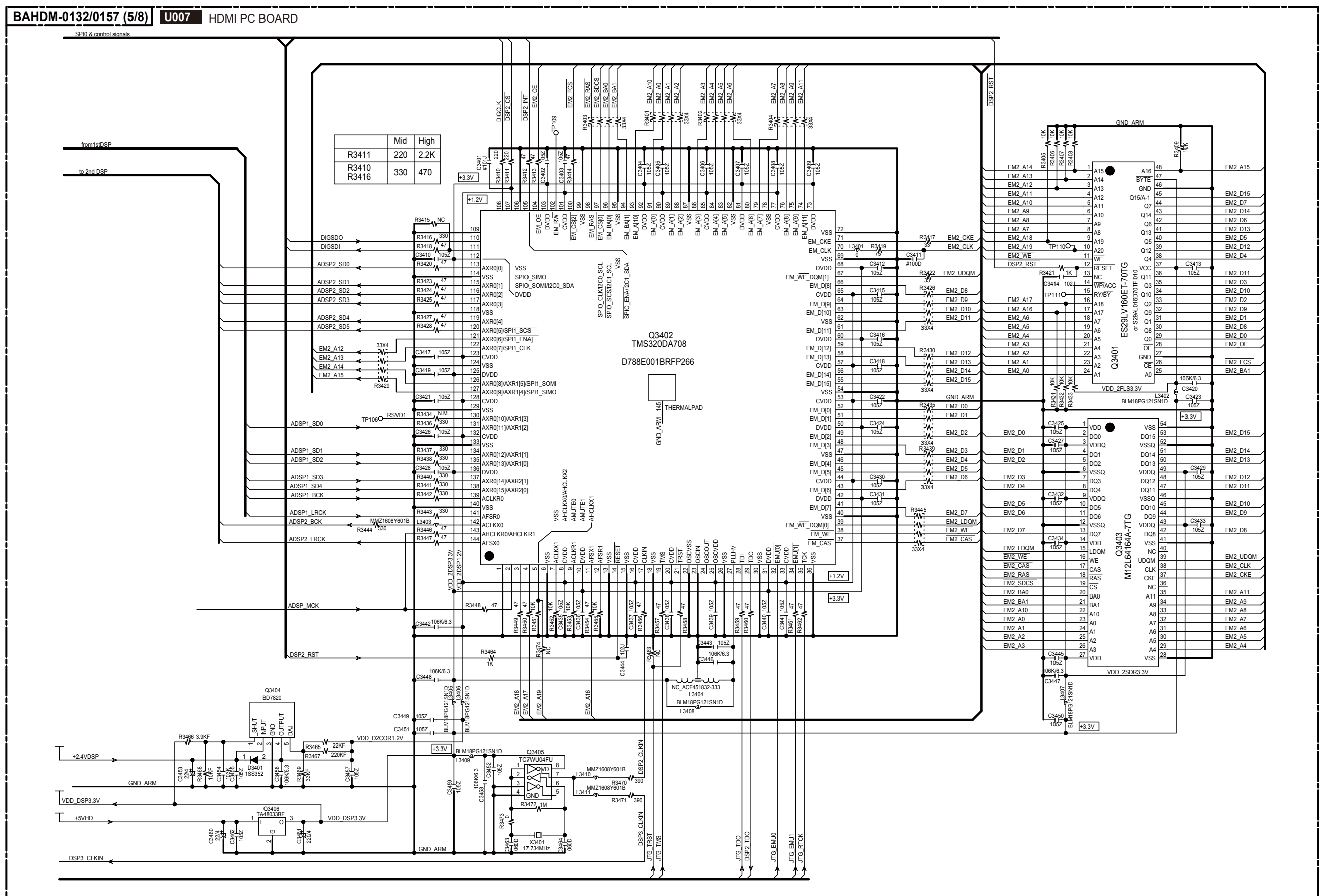

SCHEMATIC DIAGRAMS-26 / PART-31  
3RD DSP SECTION

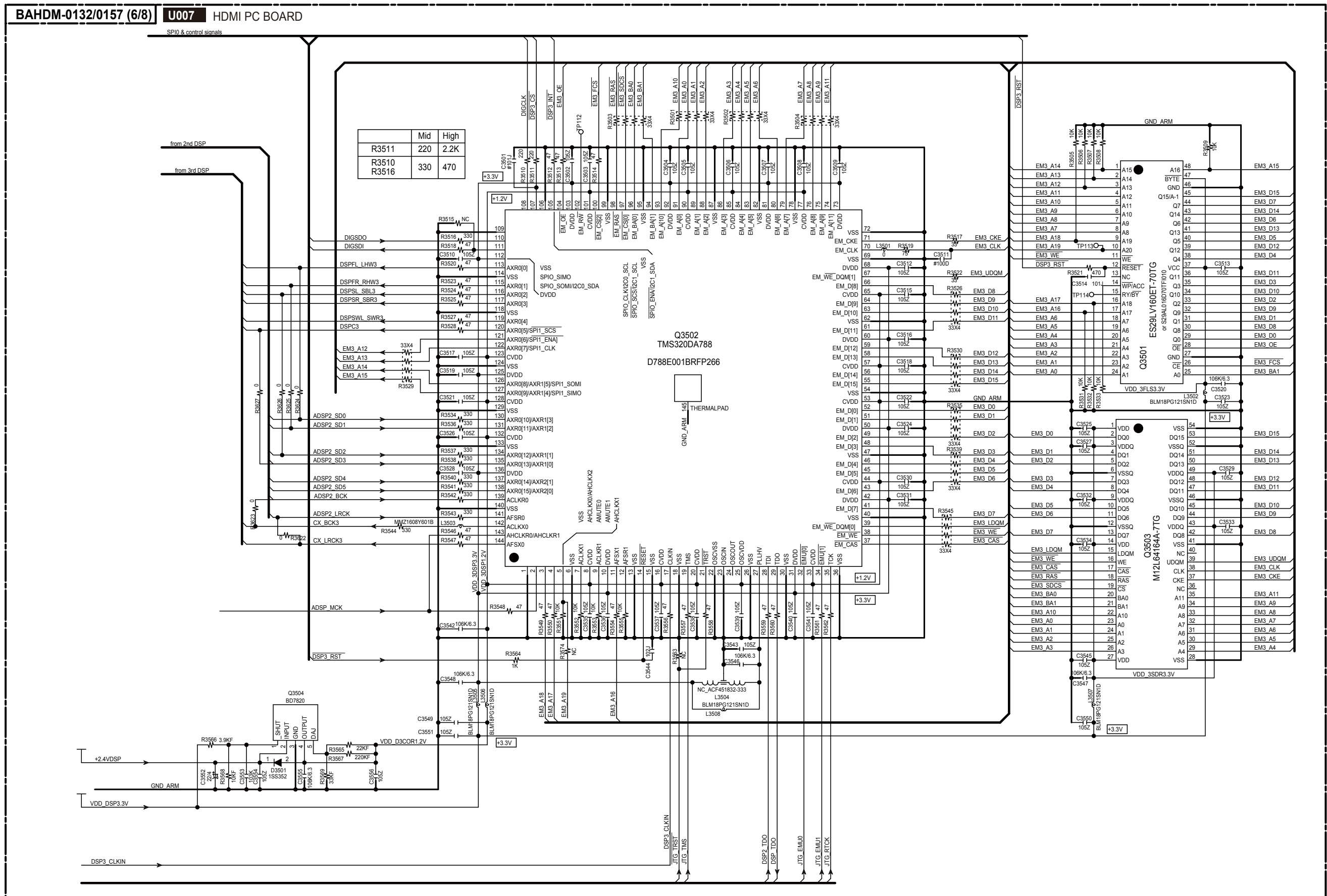

1  
2  
3  
4  
5





SCHEMATIC DIAGRAMS-28 / PART-33  
HDMI IN / ENCODER / POWER SUPPLY SECTION

BAHDM-0132/0157 (8/8) U007 HDMI PC BOARD

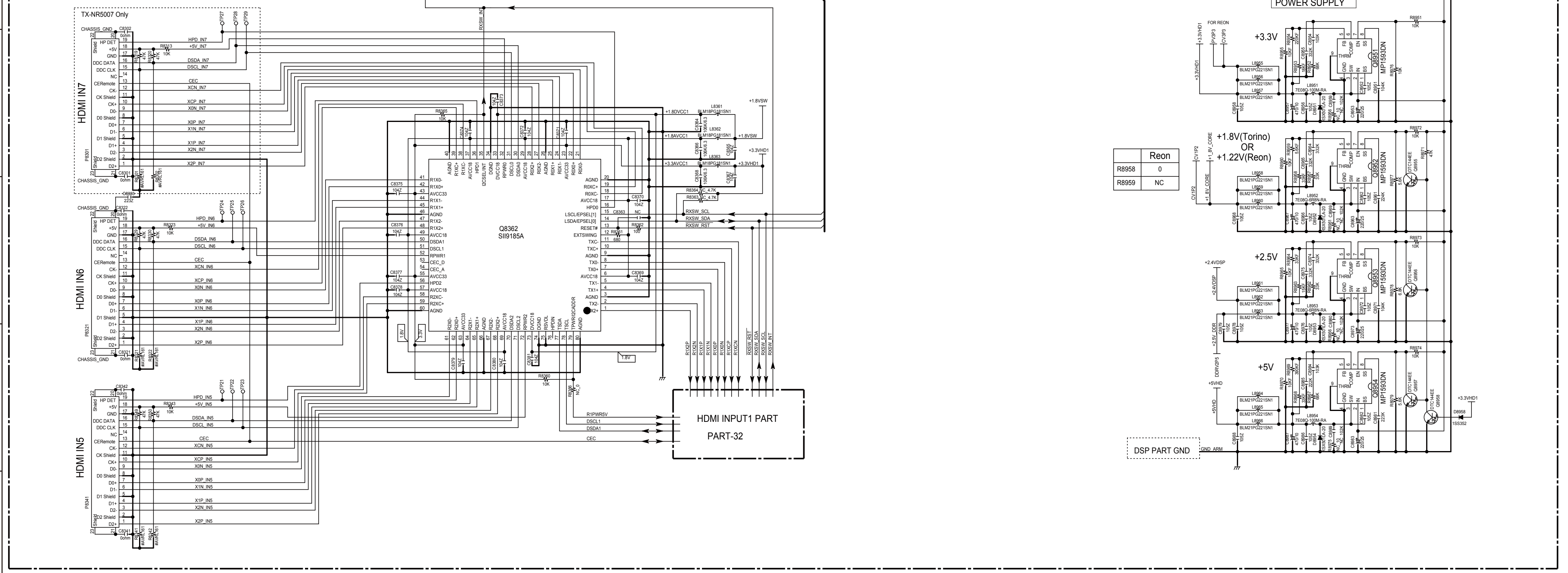
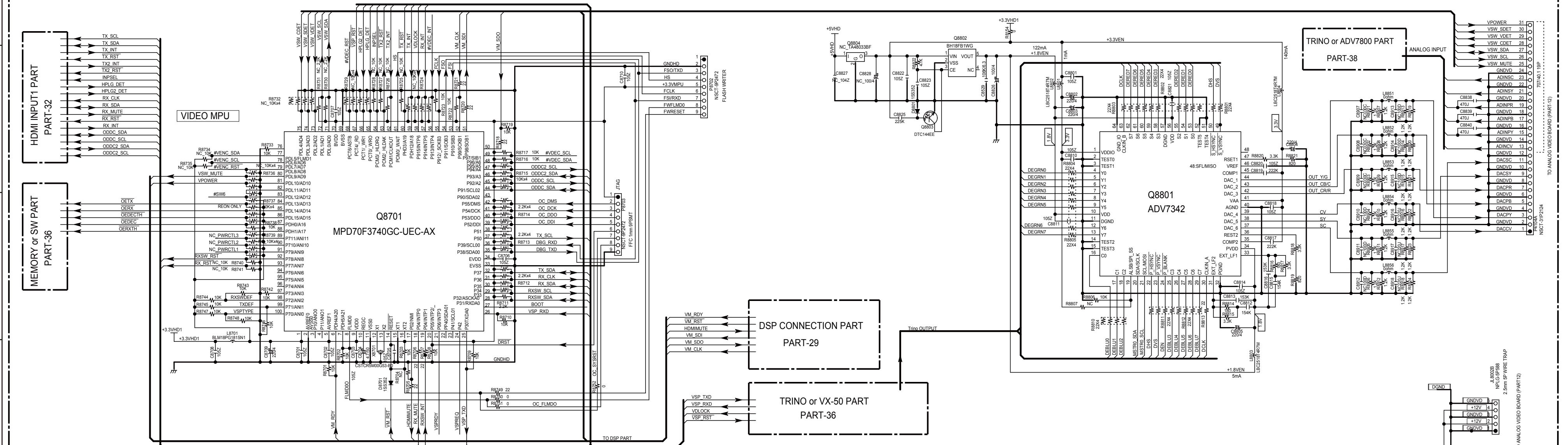





SCHEMATIC DIAGRAMS-33 / PART-38  
VIDEO DECODER / SW SECTION

BAHDM-0157 U007 HDMI PC BOARD

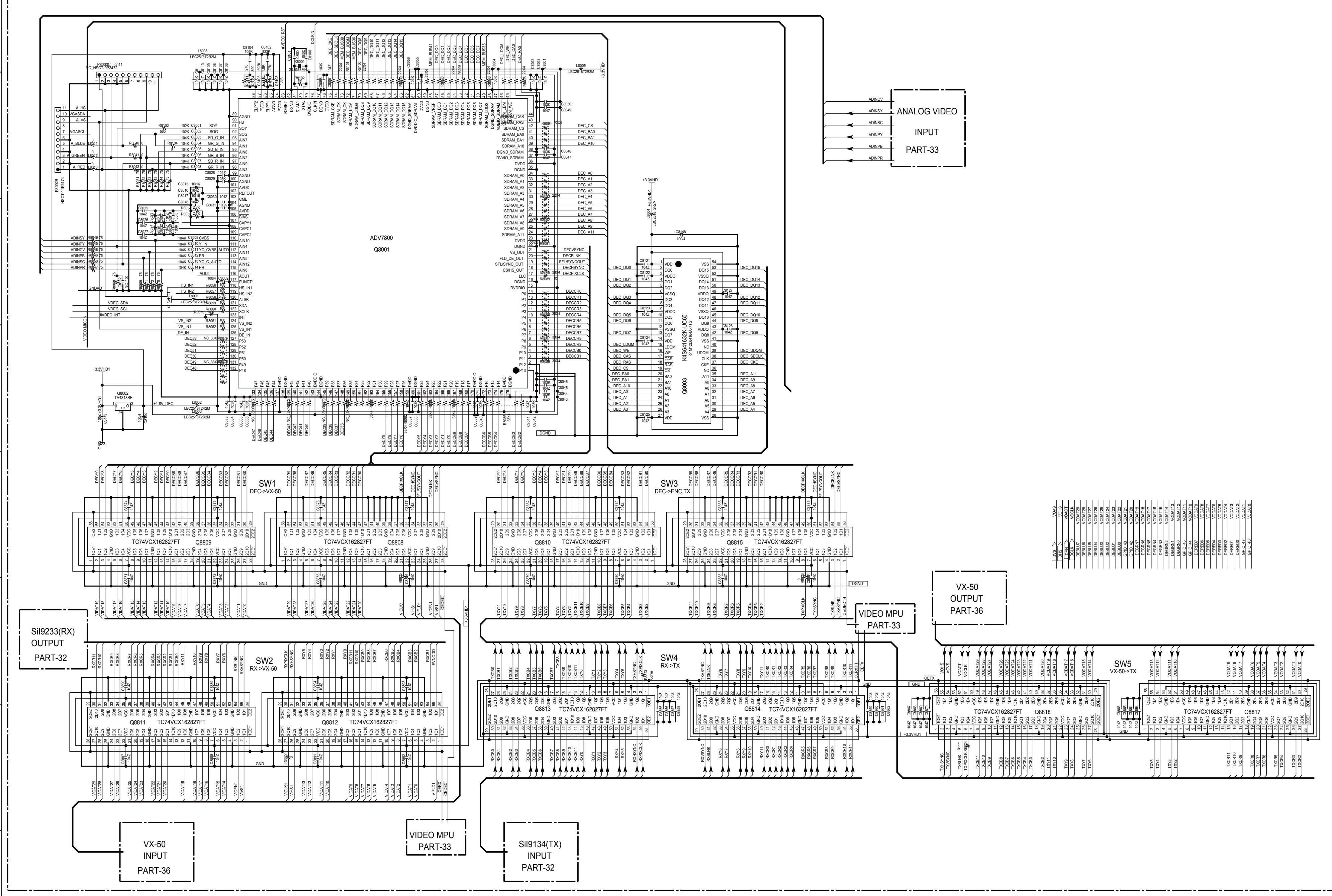

**SCHEMATIC DIAGRAMS-36 / PART-41**  
**FRONT HDMI / USB SECTION**

**BAHDM-0291 U0101** FRONT HDMI / USB PC BOARD

1  
2  
3  
4

A B C D E

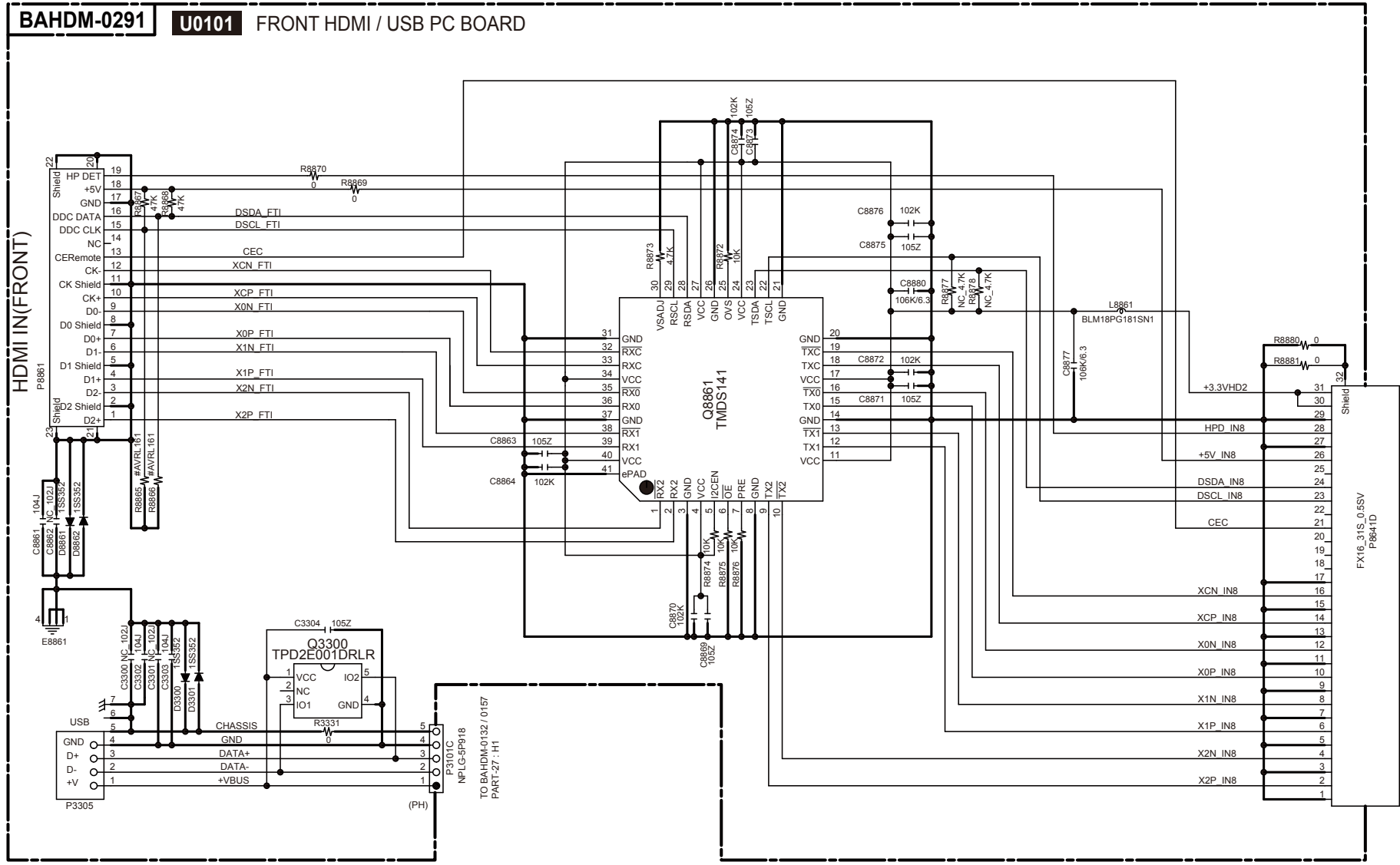

TO BAHDM-0132/0157  
 PART-32 : A6-7

**SCHEMATIC DIAGRAM-37 (PART-42)**  
**WAVEFORM SECTION**

1

**Digital Audio Waveform Part**

NOTE:  
1. (WF01) is short for (Waveform01)  
2. Refer to SD-7(SCHEMATIC DIAGRAM-9) for the location of each waveform on circuit.  
3. SD-x:XY is short for Schematic Diagram-x and each socket's location, X=A to H, Y=1 to 5.

LR CLOCK (SAI\_LRCK, CX\_LRCK)  
Fs=48kHz : DVD, Clock width=20.8us  
Fs=44.1kHz : CD, Clock width=22.7us  
  
BIT CLOCK (SAI\_SLCK, CX\_SLCK)  
64Fs=3072kHz : DVD, Clock width=325ns  
64Fs=2822.4kHz : CD, Clock width=354ns

(WF01) OPT1 (SD-11:C3)

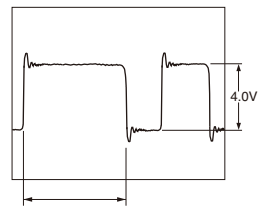

Duty varies according to audio data

(WF02) COAX1 (SD-11:D3)

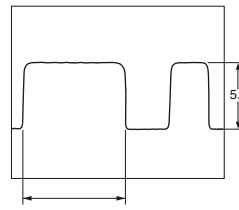

Duty always varies according to audio data

(WF03) SAI\_SDOUT/DIR\_SDOUT (SD-12:G8)

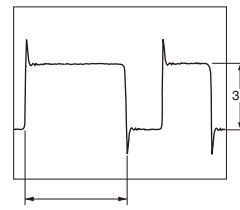

Duty varies according to audio data

(WF04) SAI\_LRCK/DIR\_LRCK (SD-12:F8)

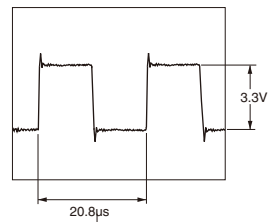

(WF05) SAI\_SLCK/DIR\_BCK (SD-12:F8)

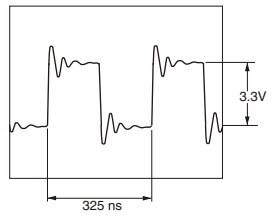

(WF06) DATA3\_PLD (SD-12:I7)

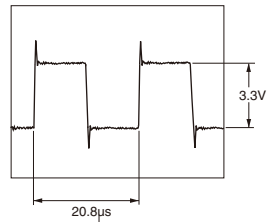

(WF07) DATA4\_PLD (SD-12:I7)

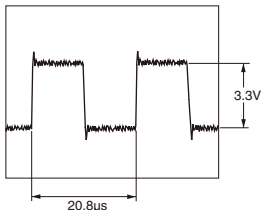

(WF08) BCK\_GND\_PLD (SD-12:I7)

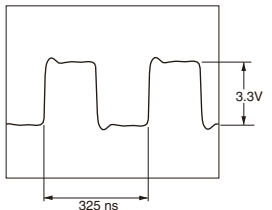

(WF09) FL+ (SD-12:B2)

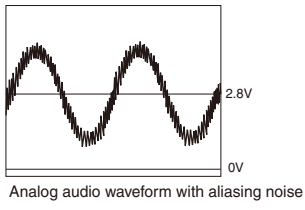

Analog audio waveform with aliasing noise

(WF10) DACFL (SD-12:F2)

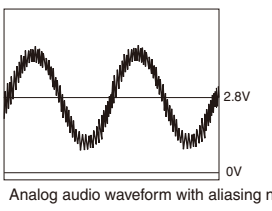

Analog audio waveform with aliasing noise

(WF10) DACFL (SD-12:F2)

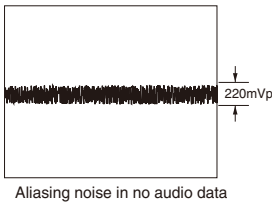

Aliasing noise in no audio data

2

3

4

5

**Video source color and pattern**

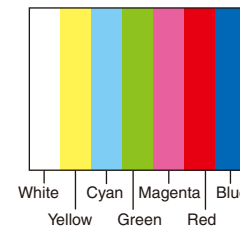

Composite waveform (WF21) SD-7:B7

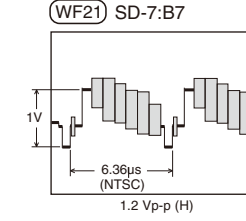

**Video Waveform Part**

S-Video Y waveform (WF22) SD-7:B7

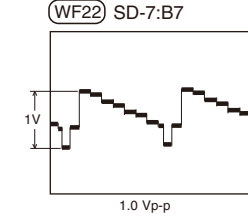

S-Video C waveform (WF23) SD-7:B7

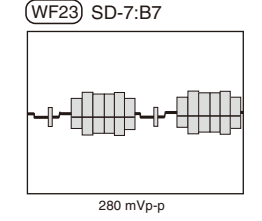

NOTE:

- (WF21) is short for (Waveform21)
- Refer to SD-5(SCHEMATIC DIAGRAM-6) for the location of each waveform on circuit.
- SD-x:XY is short for Schematic Diagram-x and each socket's location, X=A to H, Y=1 to 5.
- In the case that video outputs are not connected to video devices, video signal output levels are doubled.

Component Y waveform (WF24) SD-7:B3-4

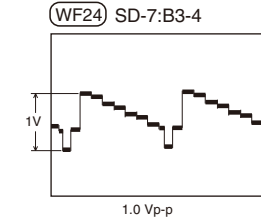

Component PB waveform (WF25) SD-7:B3-4

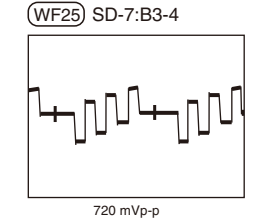

Component PR waveform (WF26) SD-7:B3-4

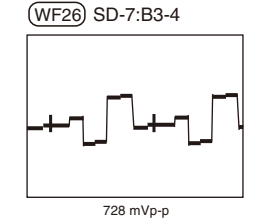

**HDMI Waveform Part**

HDMI D0,D1,D2 waveform (WF41) SD-27:B8,J7 SD-28:B8

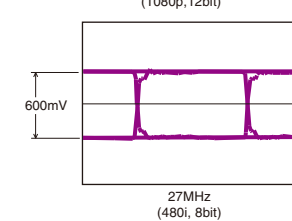
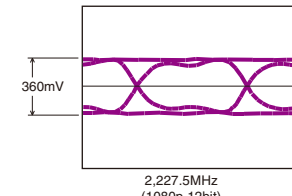

D0,D1,D2 Eye-pattern waveform, frequency and level vary according to video resolution, aspect and profile. Waveforms above are examples.

HDMI CK waveform (WF42) SD-27:B8,J7 SD-28:B8

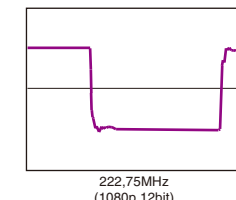

CK waveform, frequency and level differ according to video resolution, aspect and profile. D0,D1,D2 are just CK x10.

**FL Driver IC Control Waveform Part**

SCK/SDATA waveform (WF61) SD-14:F4,I4 SD-16:F4,I4

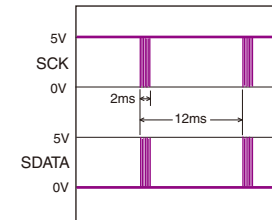

SCK/SDATA waveform (WF61) SD-14:F4,I4 SD-16:F4,I4

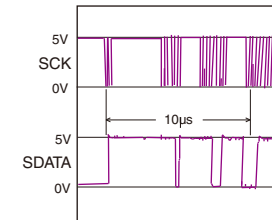

SDATA waveform varies according to the data content

SCK/CS waveform (WF62) SD-14:F4,H4 SD-16:F4,H4

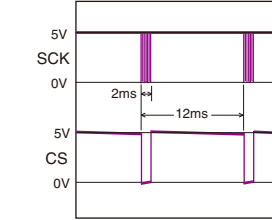

SCK/RESET waveform (WF63) SD-14:F4,H4 SD-16:F4,H4

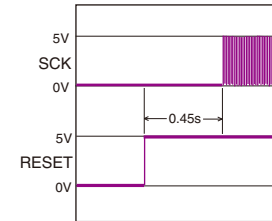

When power on

SCK/RESET waveform (WF63) SD-14:F4,H4 SD-16:F4,H4

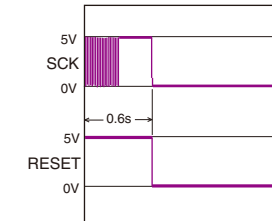

When power off

PRINTED CIRCUIT BOARD VIEWS-01 / U001

**U0010 POWER SUPPLY PC BOARD (BAAF-0180)**  
Component side view from soldering side

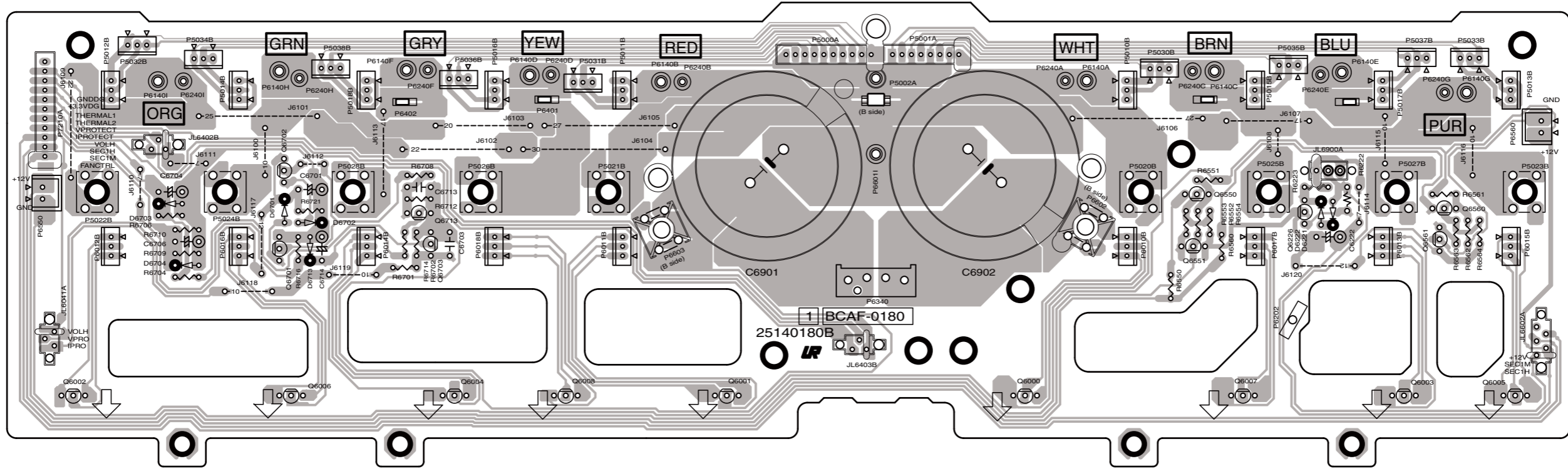

**U0011 DIODE PC BOARD (BAPS-0181)**  
Component side view from soldering side

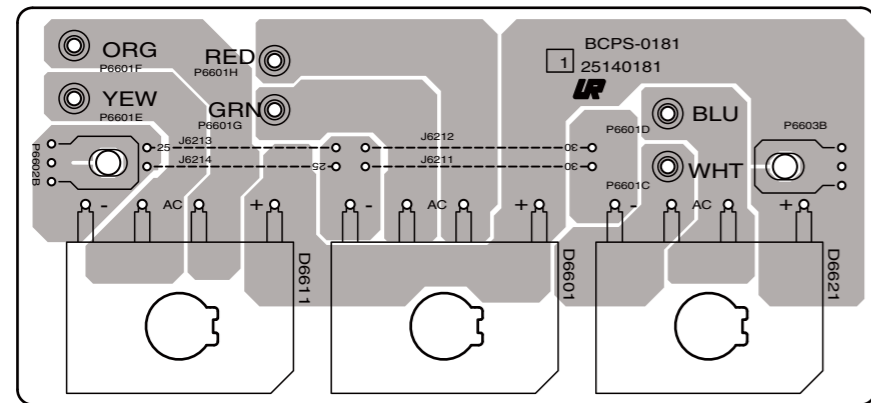

**U0012 RELAY PC BOARD (BAPS-0182)**  
Component side view from soldering side

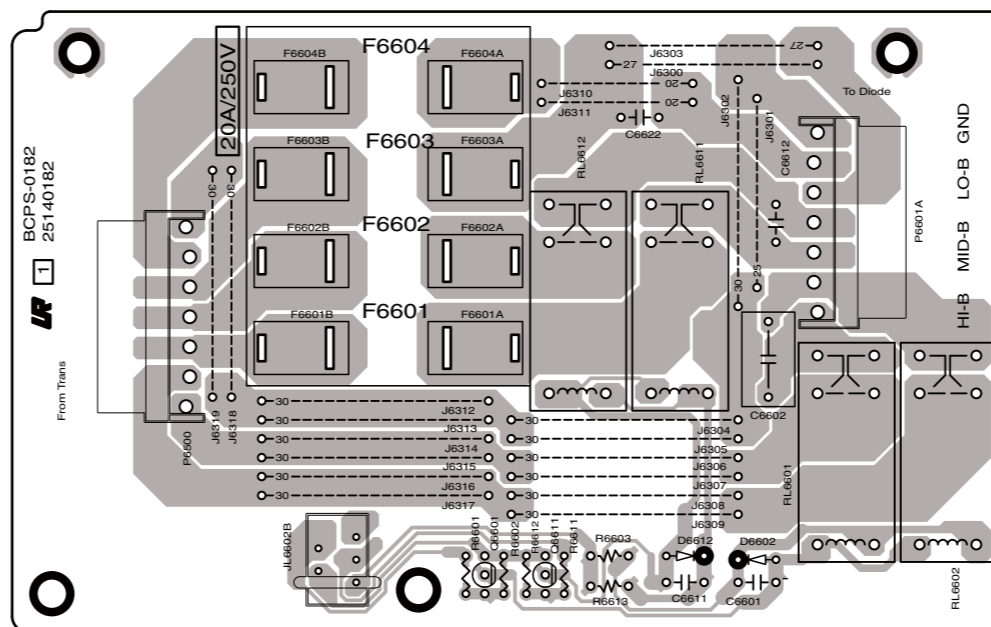

**U0013 THERMAL SENSOR CIRCUIT PC BOARD (BAETC-0183)**  
Component side view from soldering side

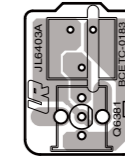

**U0014 THERMAL SENSOR CIRCUIT PC BOARD (BAETC-0184)**  
Component side view from soldering side

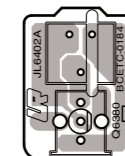

1

2

3

4

5



A B C D E F G H

PRINTED CIRCUIT BOARD VIEWS-02 / U001

U0010 POWER SUPPLY PC BOARD (BAAF-0180)

Soldering side view from component side

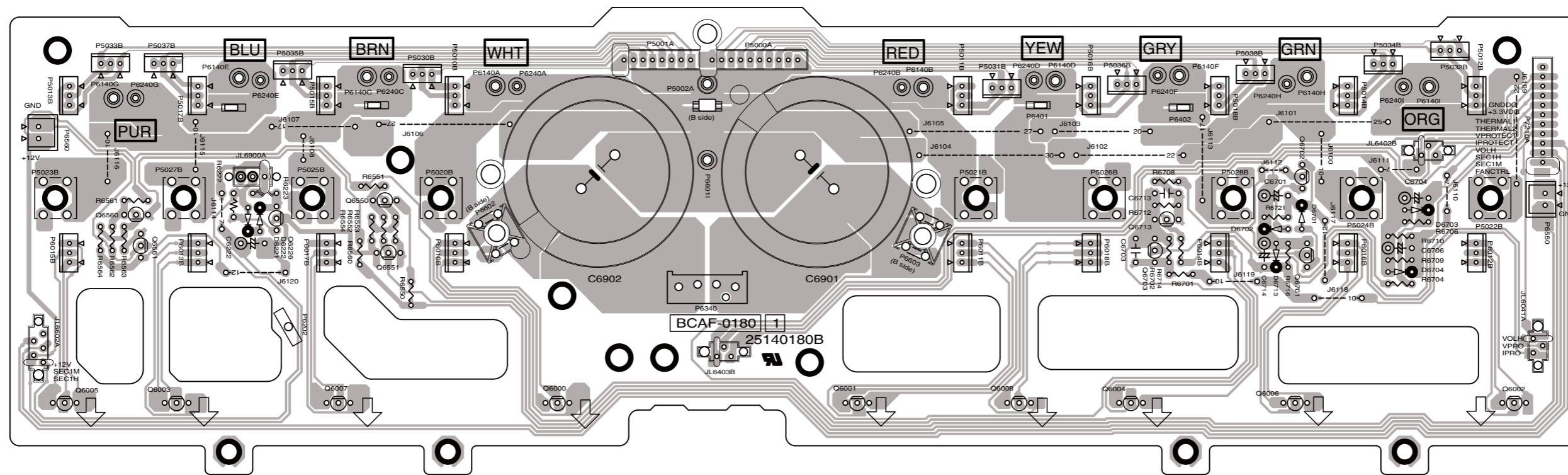

U0011 DIODE PC BOARD (BAPS-0181)

Soldering side view from component side

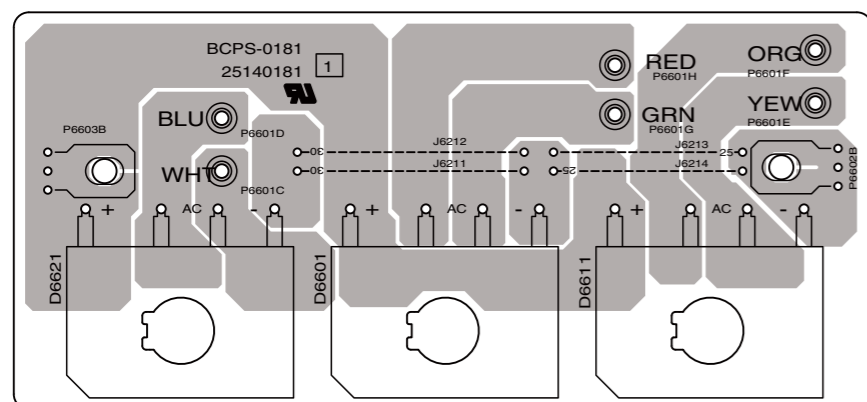

U0012 RELAY PC BOARD (BAPS-0182)

Soldering side view from component side

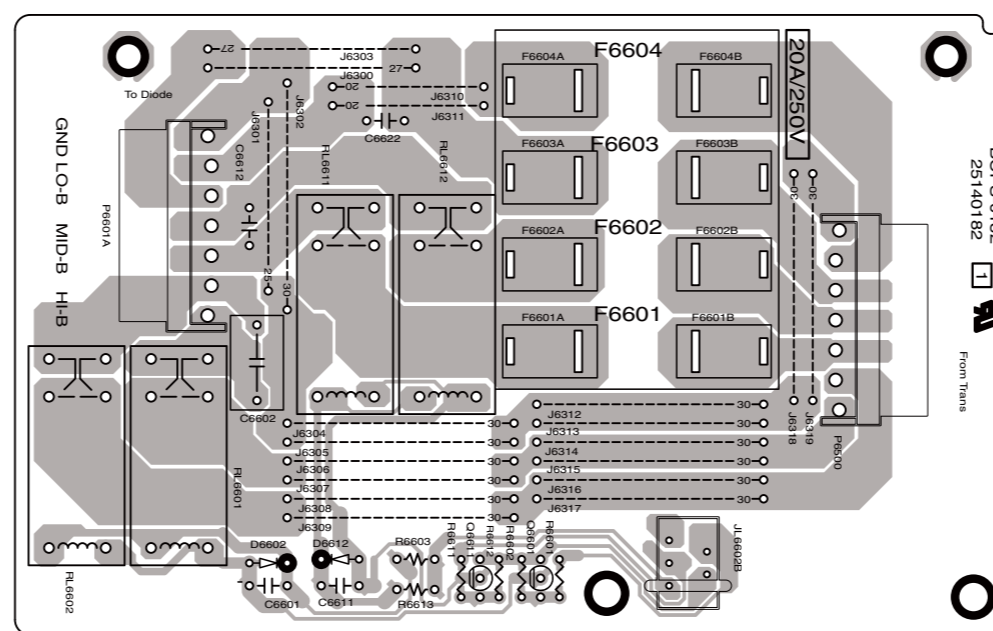

U0013 THERMAL SENSOR CIRCUIT PC BOARD (BAETC-0183)

Soldering side view from component side

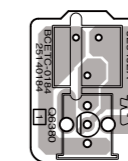

U0014 THERMAL SENSOR CIRCUIT PC BOARD (BAETC-0184)

Soldering side view from component side

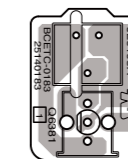

1

2

3

4

5

A B C D E F G H

PRINTED CIRCUIT BOARD VIEWS-03 / U002

**U0020** AMPLIFIER PC BOARD (C,SR,RH,SBR,R) (BAAMP-0191)

Component side view from soldering side

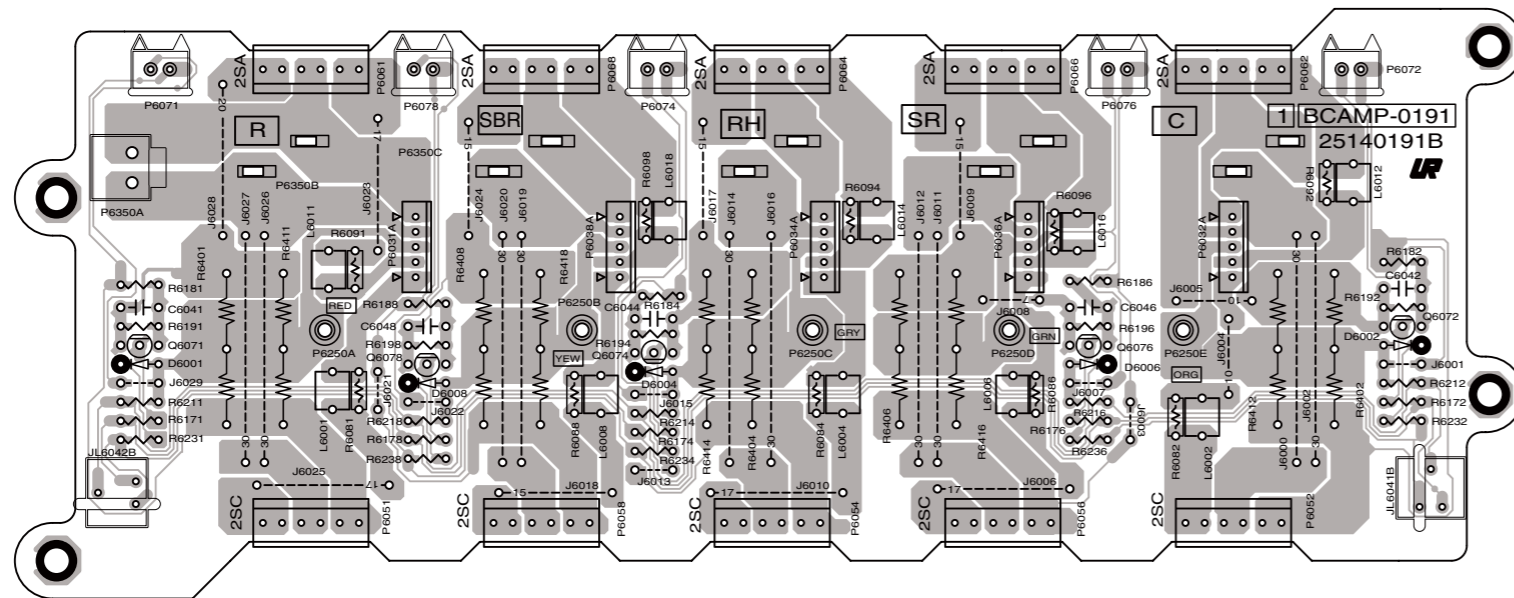

Soldering side view from component side

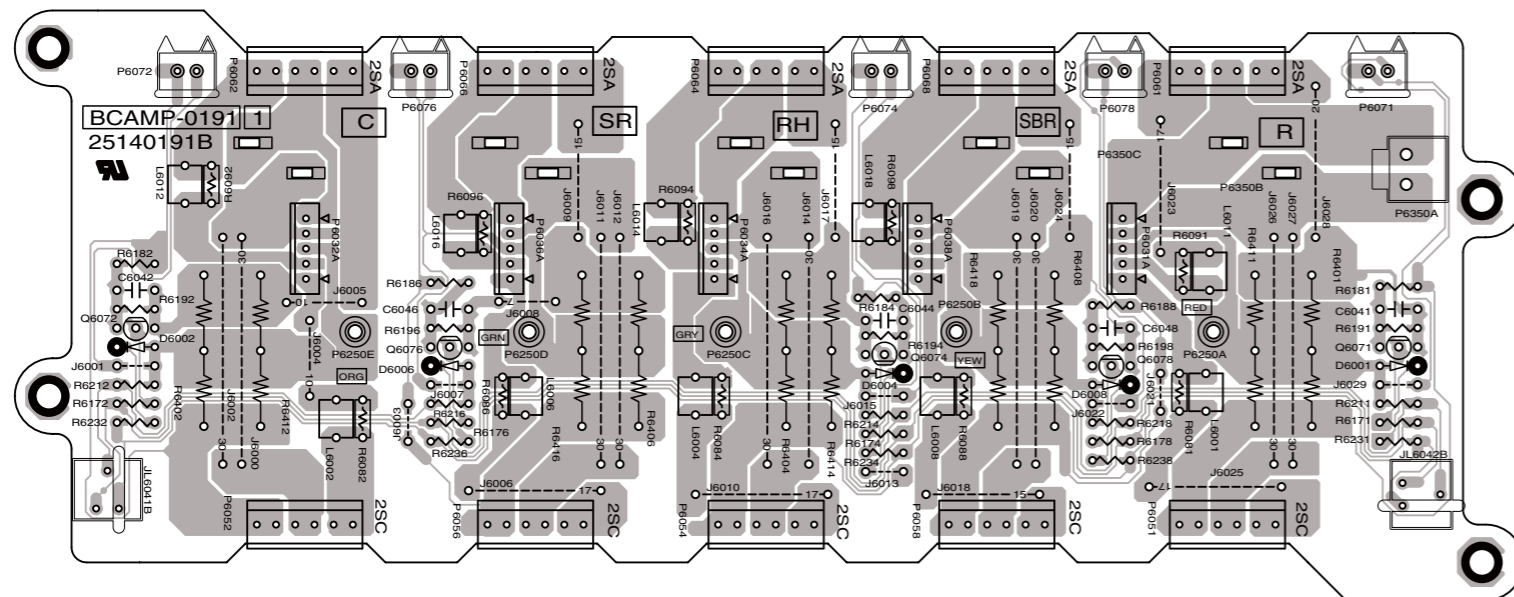

**U0021** AMPLIFIER PC BOARD (L,SBL,LH,SL) (BAAMP-0192)

Component side view from soldering side

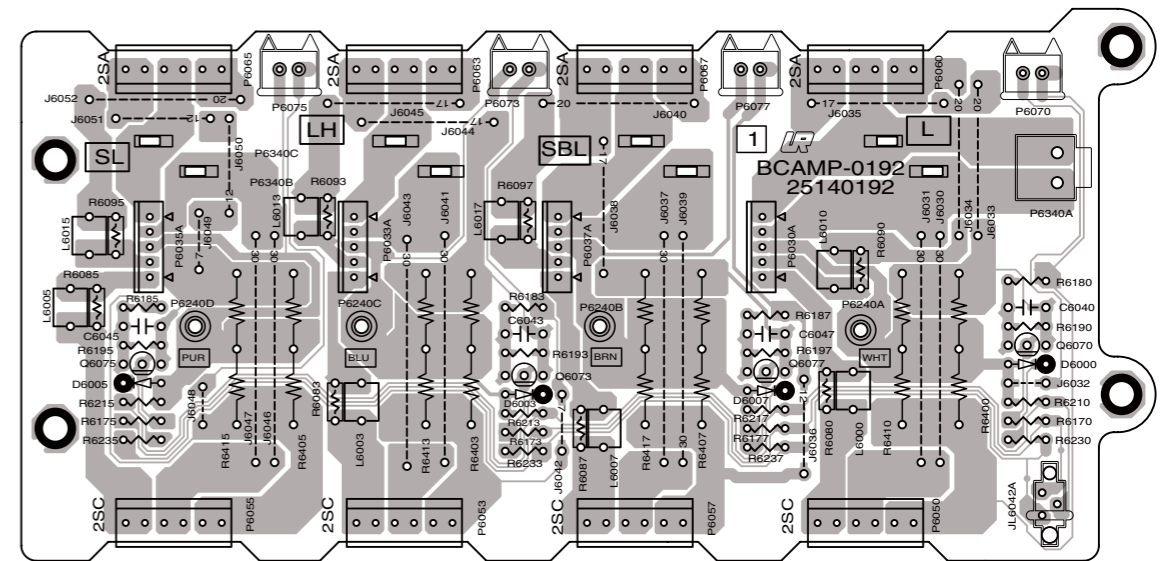

Soldering side view from component side

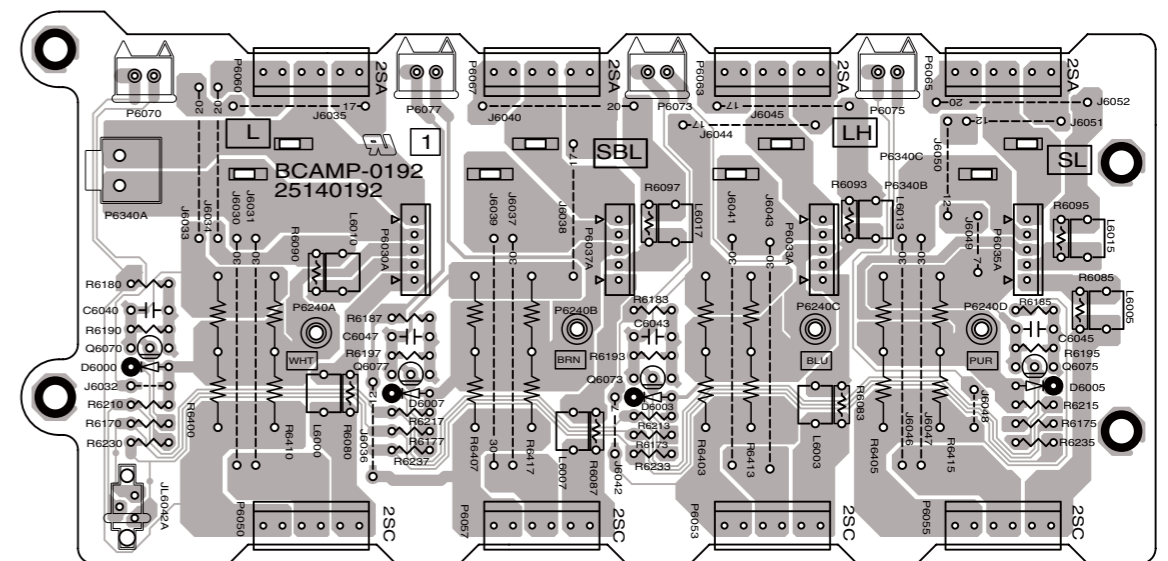

1

2

3

4

5

A B C D E F G H

PRINTED CIRCUIT BOARD VIEWS-04 / U003

U0030 ANALOG AUDIO PC BOARD (BAASP-0202)

Component side view from soldering side

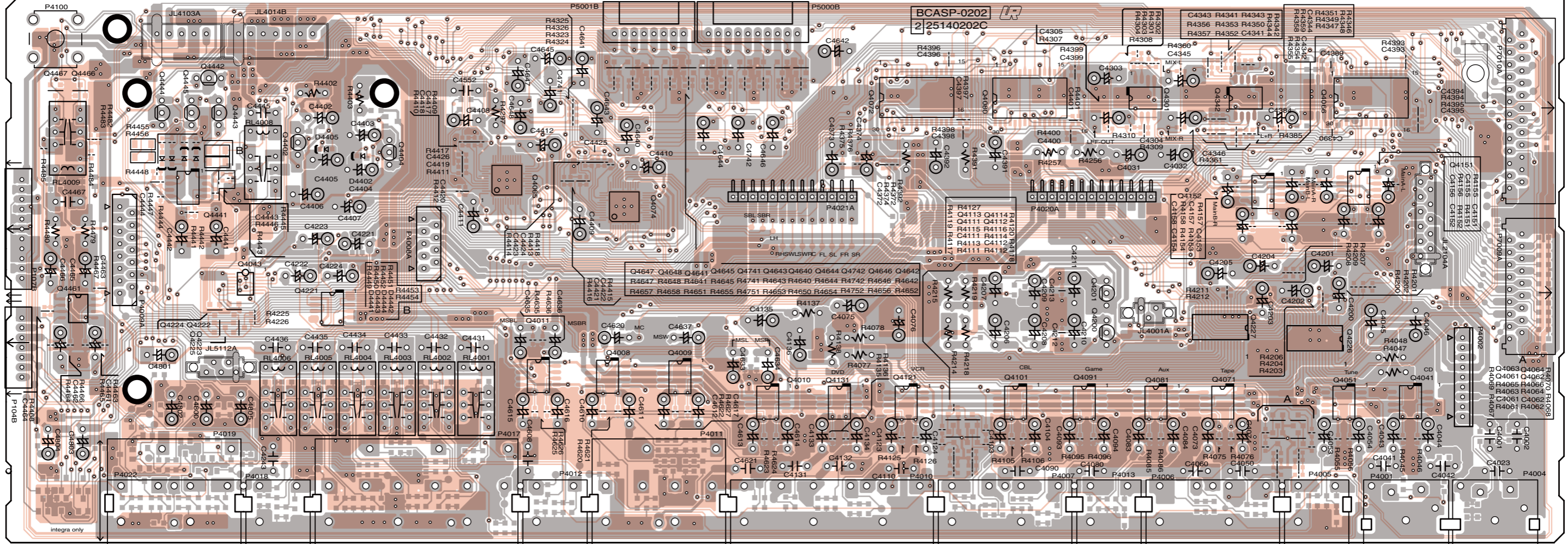

- Z3SW/Z3L/Z3R
- Z2SW/Z2L/Z2R
- LH/RH OUT
- SWR/SBL/SBR OUT
- SWL/SL/SR OUT
- C/L/R OUT
- SBL/SBR OUT
- SW/SL/SR
- C/L/R
- DVD
- VCR IN
- VCR OUT
- CBL/SAT
- GAME/TV
- AUX2
- TAPE IN
- TAPE OUT
- TUNE
- CD
- PHONO

1

2

3

4

5

A B C D E F G H  
PRINTED CIRCUIT BOARD VIEWS-05 / U003

**U0030** ANALOG AUDIO PC BOARD (BAASP-0202)

Soldering side view from component side

1  
2  
3  
4  
5

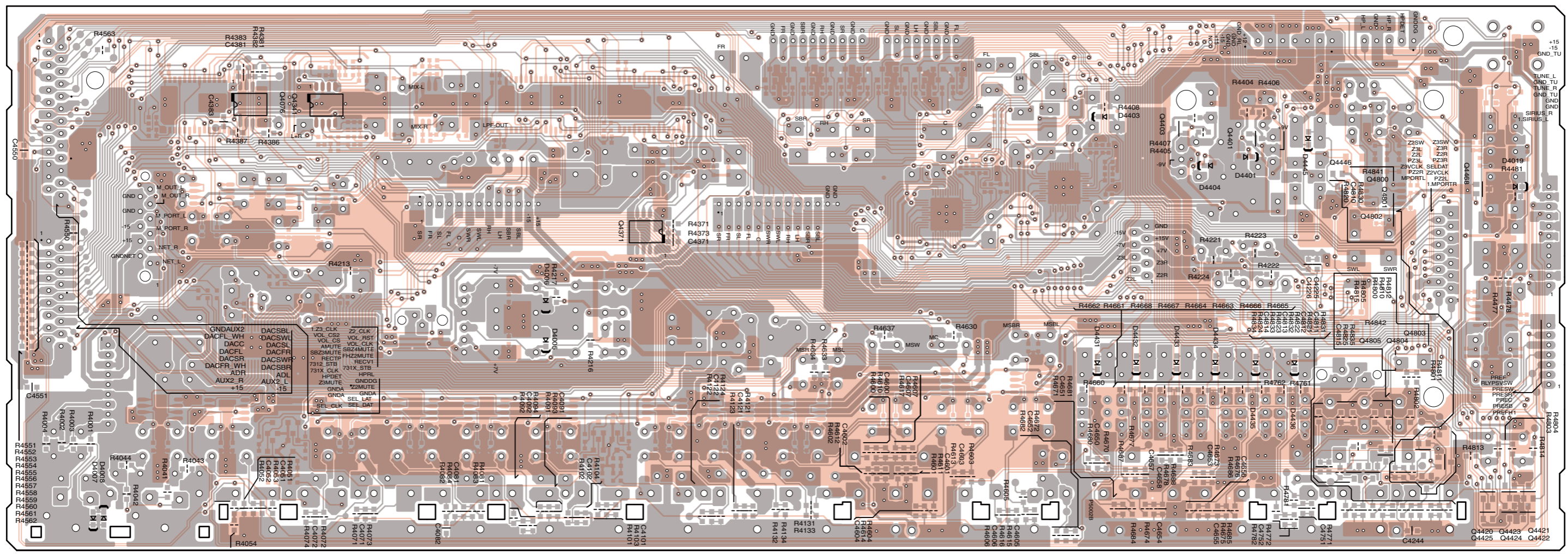

PRINTED CIRCUIT BOARD VIEWS-06 / U003

U0031 ANALOG VIDEO PC BOARD (BAVD-0203)

Component side view from soldering side

1

2

3

4

5

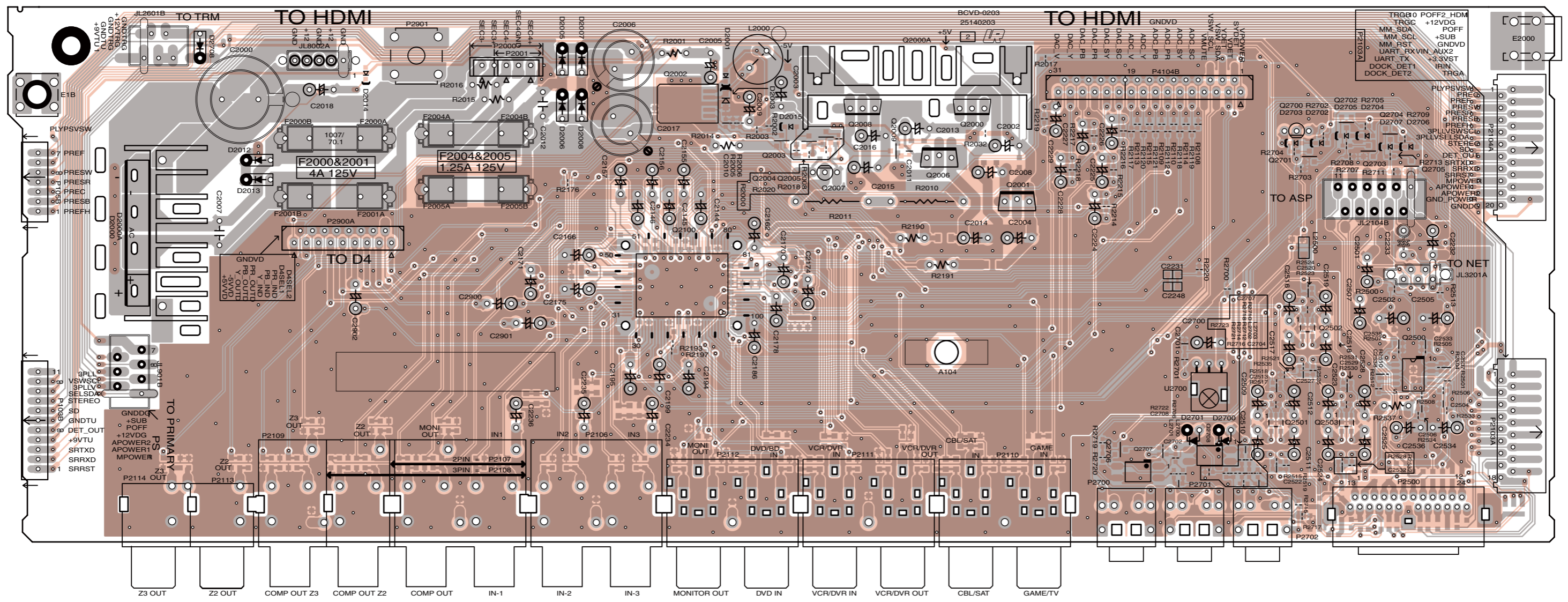

Z3 OUT Z2 OUT COMP OUT Z3 COMP OUT Z2 COMP OUT IN-1 IN-2 IN-3 MONITOR OUT DVD IN VCR/DVR IN VCR/DVR OUT CBL/SAT GAME/TV

A B C D E F G H

PRINTED CIRCUIT BOARD VIEWS-07 / U003

U0030 ANALOG VIDEO PC BOARD (BAVD-0203)

Soldering side view from component side

1

2

3

4

5

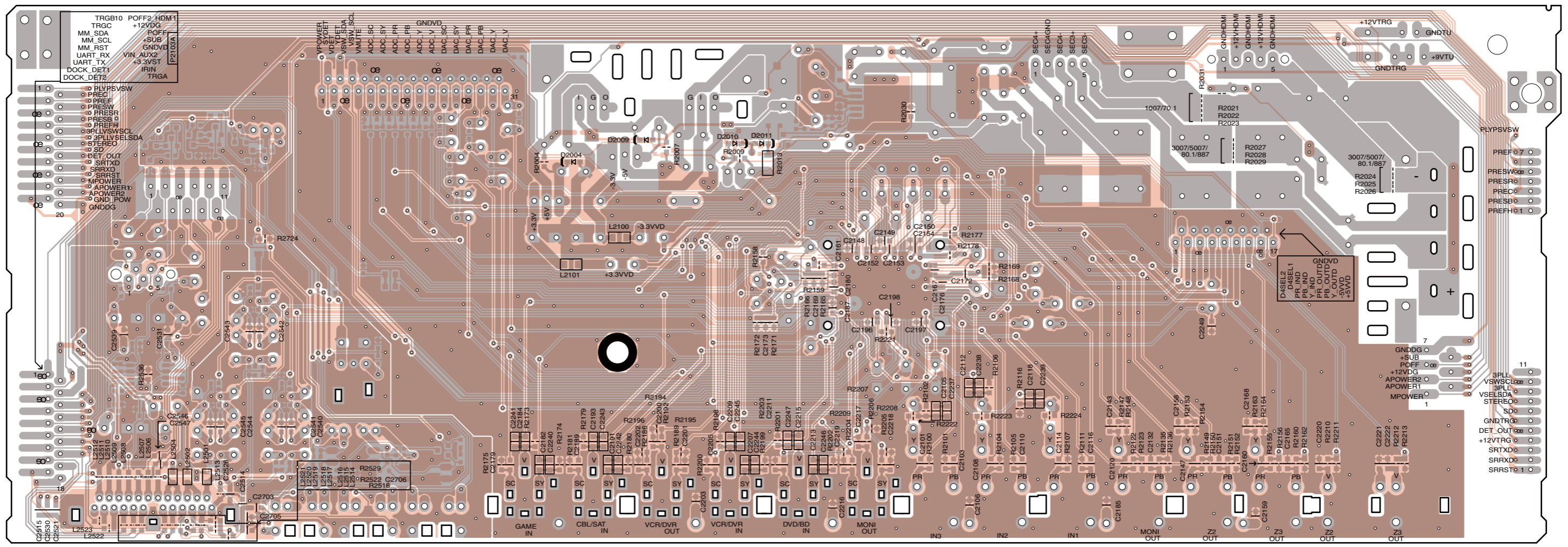

PRINTED CIRCUIT BOARD VIEWS-08 / U004

U0040 CODEC, DAC PC BOARD (BADG-0208)

1  
2  
3  
4  
5

Component side view from soldering side

Soldering side view from component side

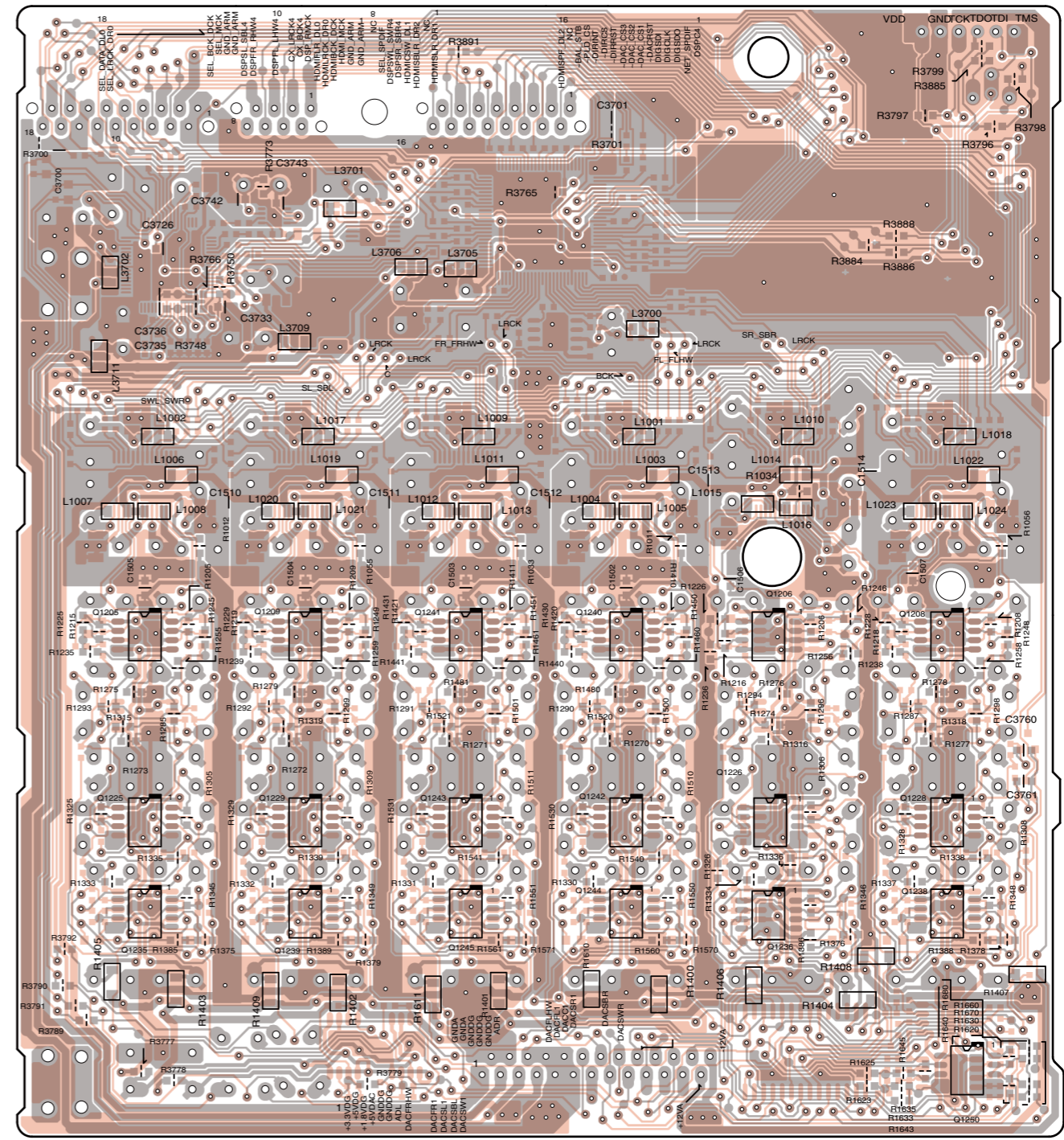
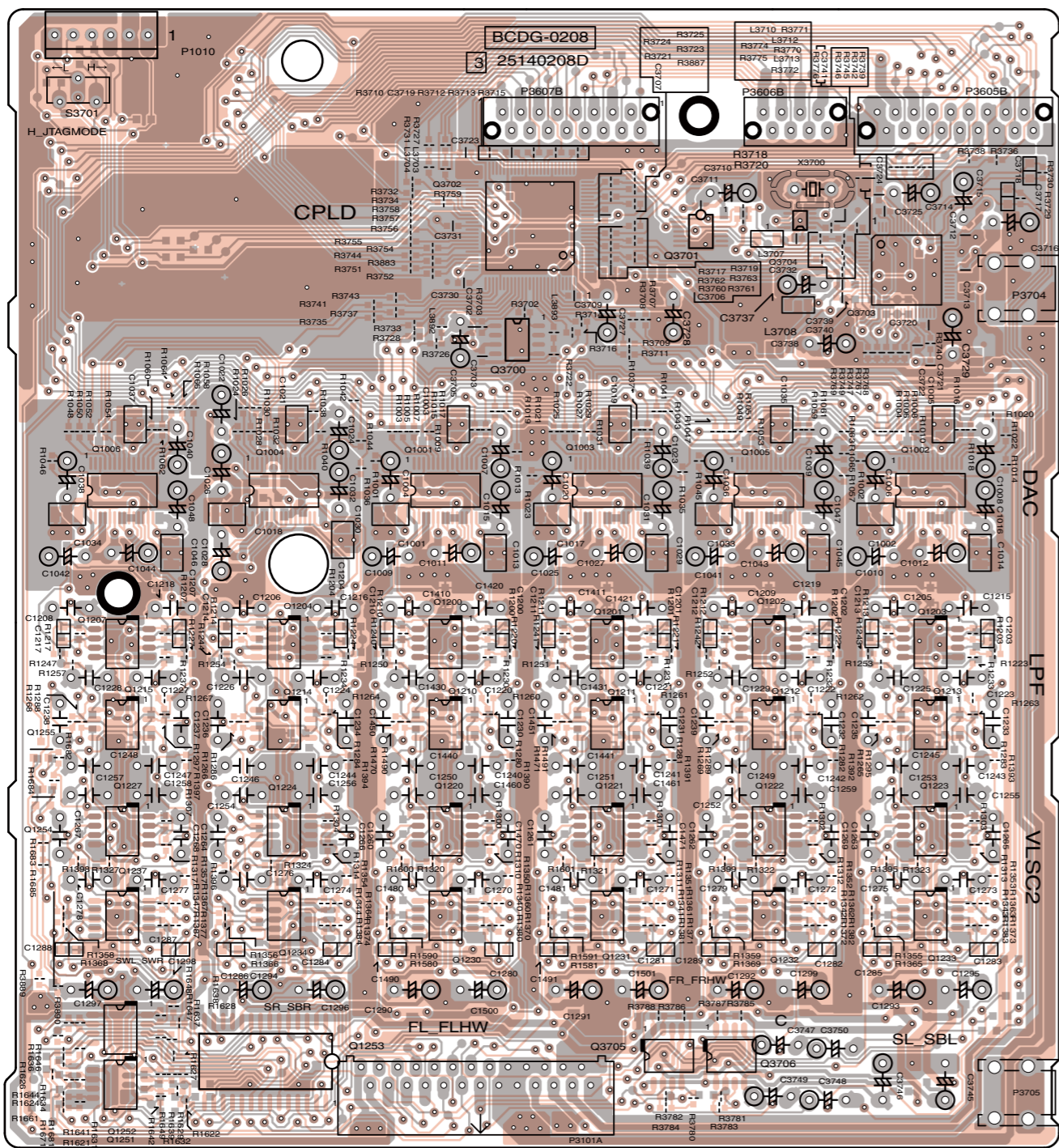

PRINTED CIRCUIT BOARD VIEWS-09 / U004

U0041 MAIN CPU PC BOARD (BACPU-0209)

1

Component side view from soldering side

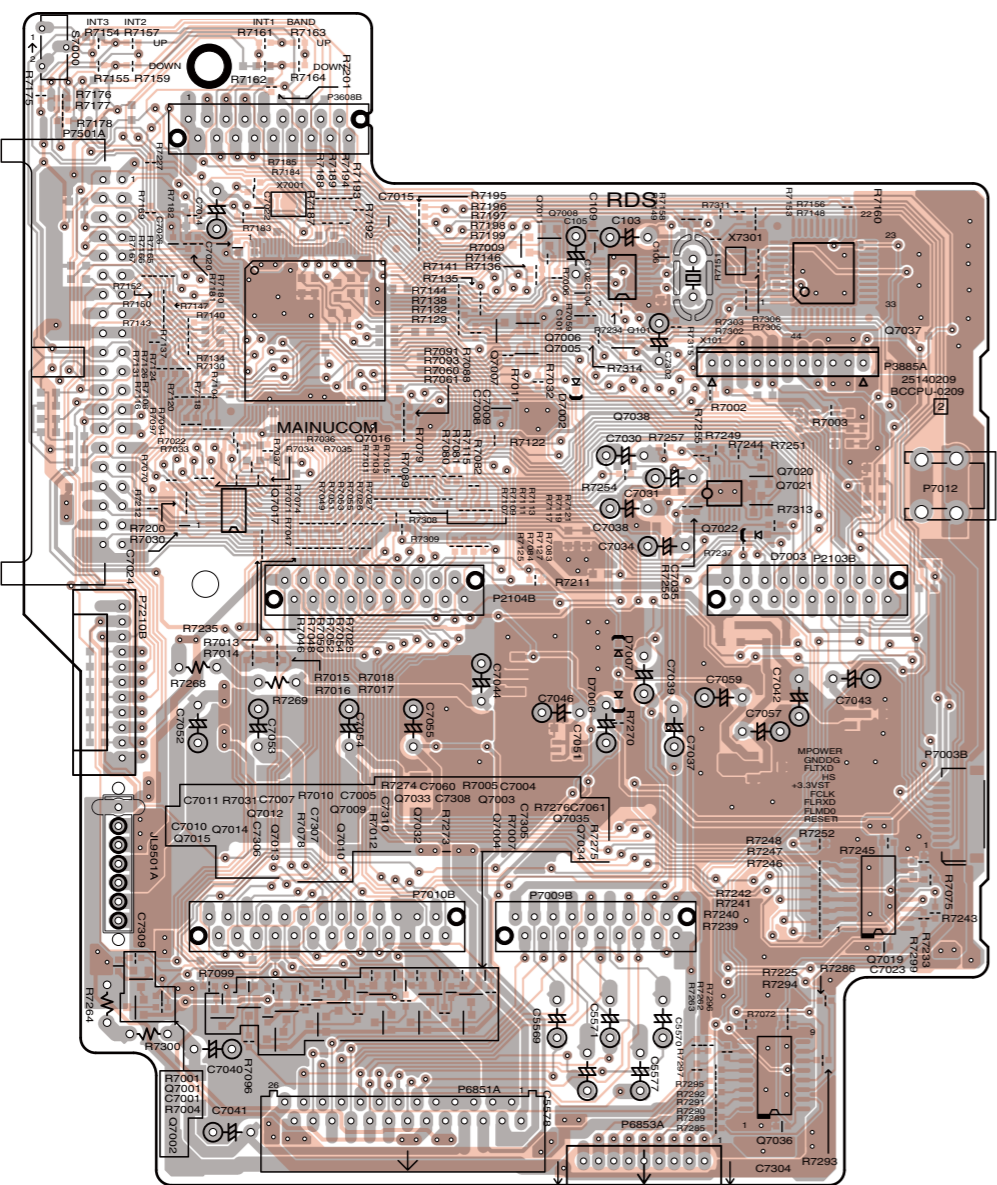

2

Soldering side view from component side

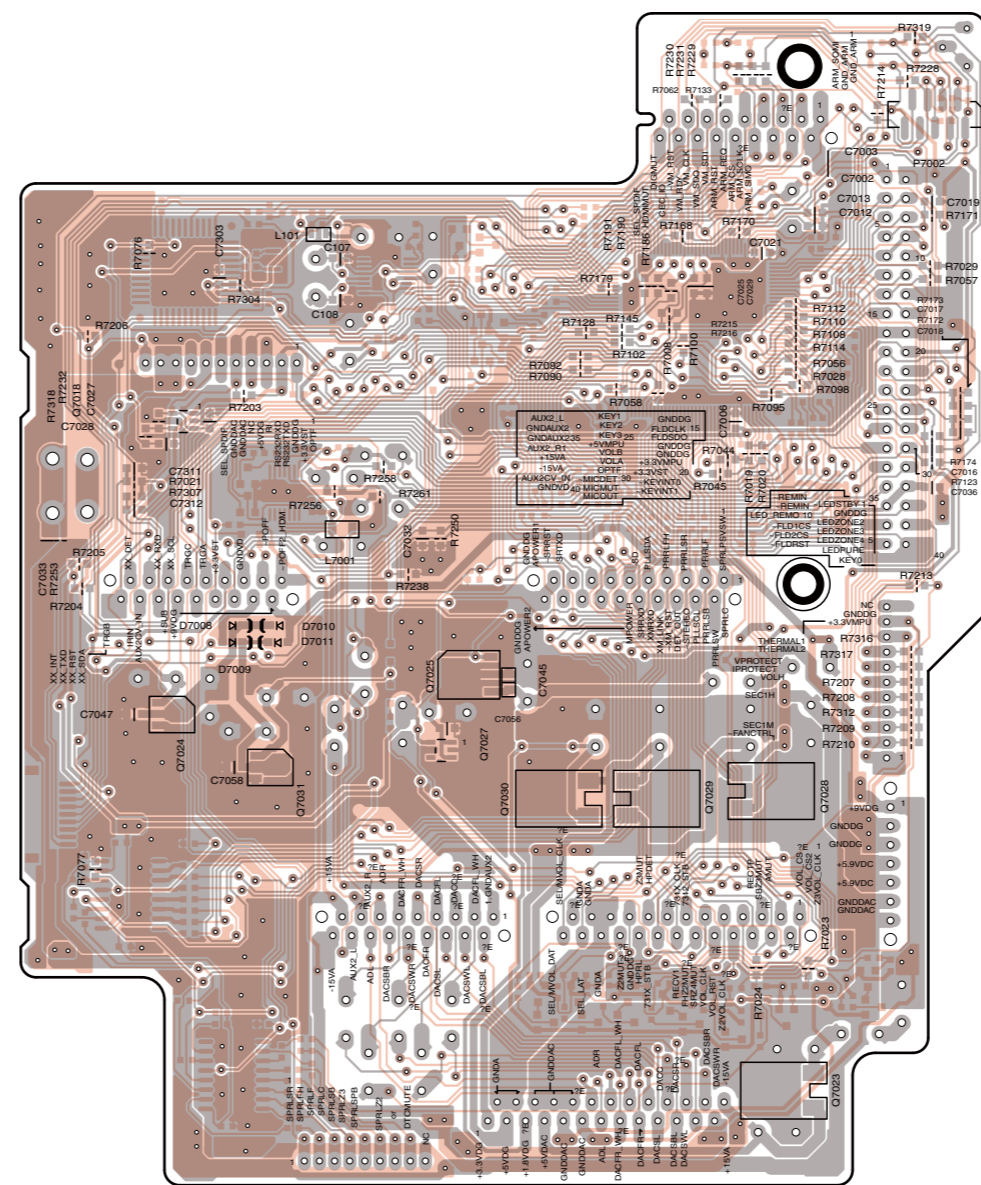

3

4

U0042 ZONE-2 & ZONE-3 CIRCUIT PC BOARD (BAAR-0210)

Component side view from soldering side

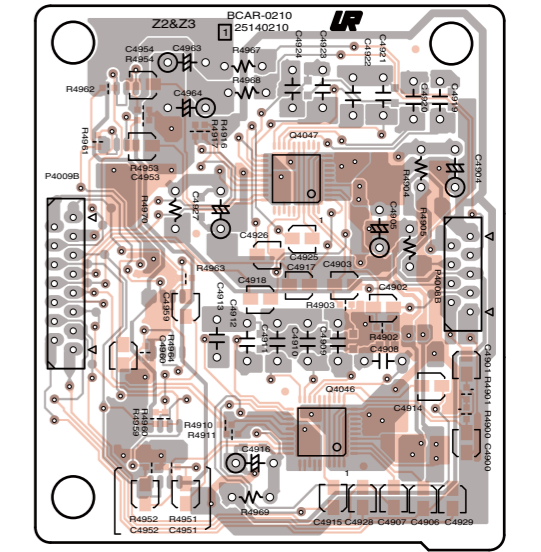

Soldering side view from component side

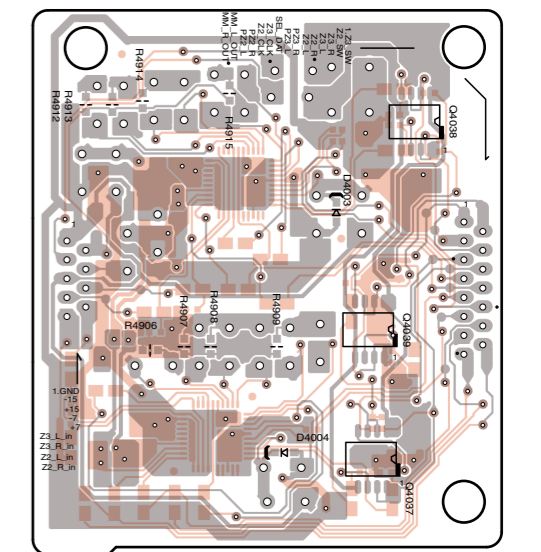

U0044 BUFFER AMP. CIRCUIT PC BOARD (BAACC-0212)

5

Component side view from soldering side

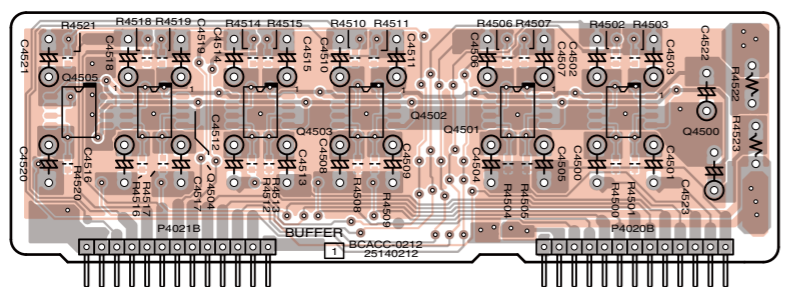

Soldering side view from component side

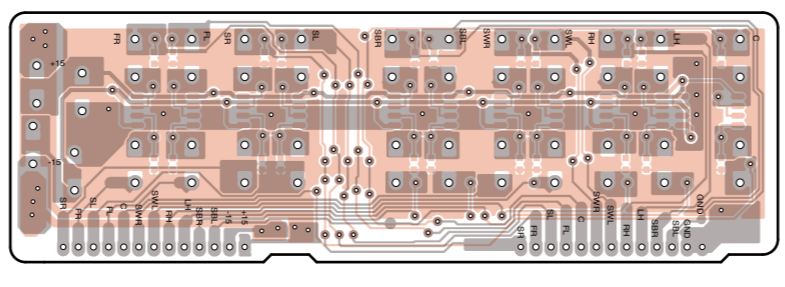





A B C D E F G H

PRINTED CIRCUIT BOARD VIEWS-11 / U005

**U0050 DISPLAY PC BOARD (BADIS-0135)**

Component side view from soldering side

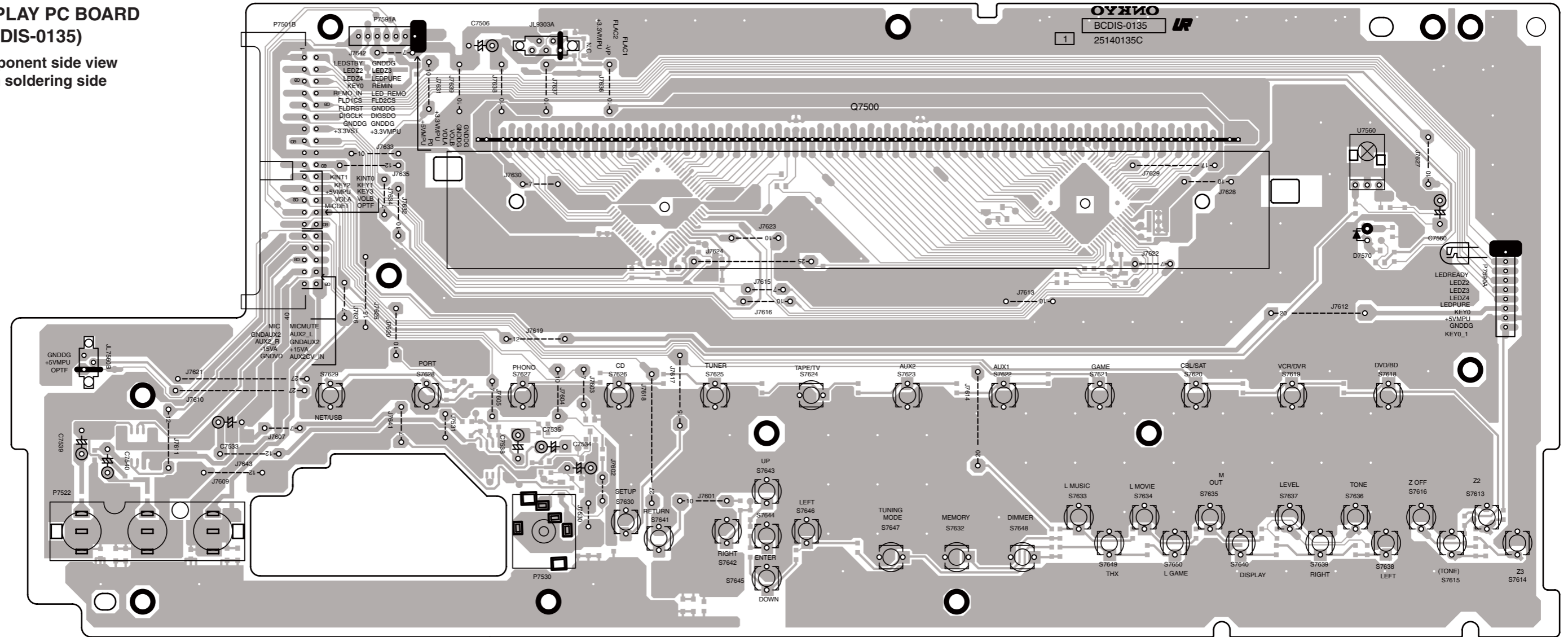

**U0054 VOLUME PC BOARD (BAETC-0139)**

Component side view from soldering side

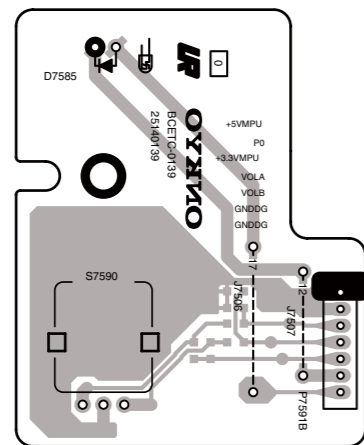

**U0052 HEADPHONE JACK PC BOARD (BAETC-0137)**

Component side view from soldering side

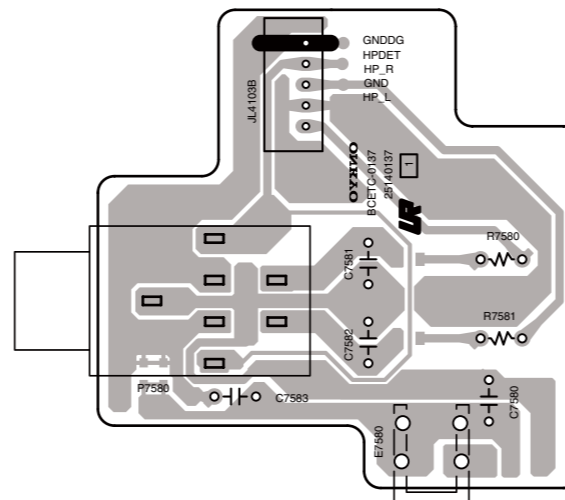

**U0051 SWITCH PC BOARD (BASW-0136)**

Component side view from soldering side

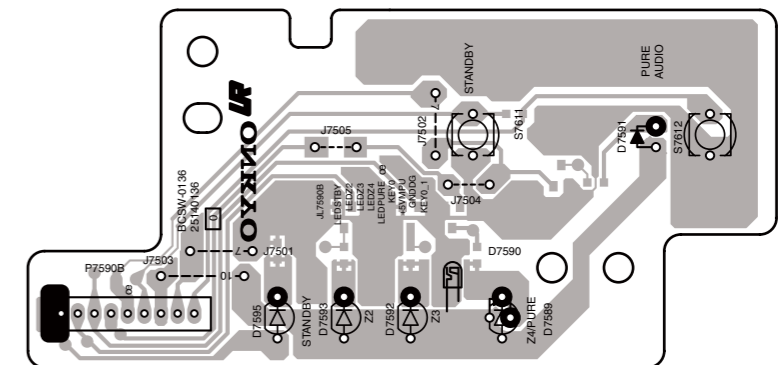

1

2

3

4

5

PRINTED CIRCUIT BOARD VIEWS-12 / U005

**U0050 DISPLAY PC BOARD (BADIS-0135)**  
Soldering side view from component side

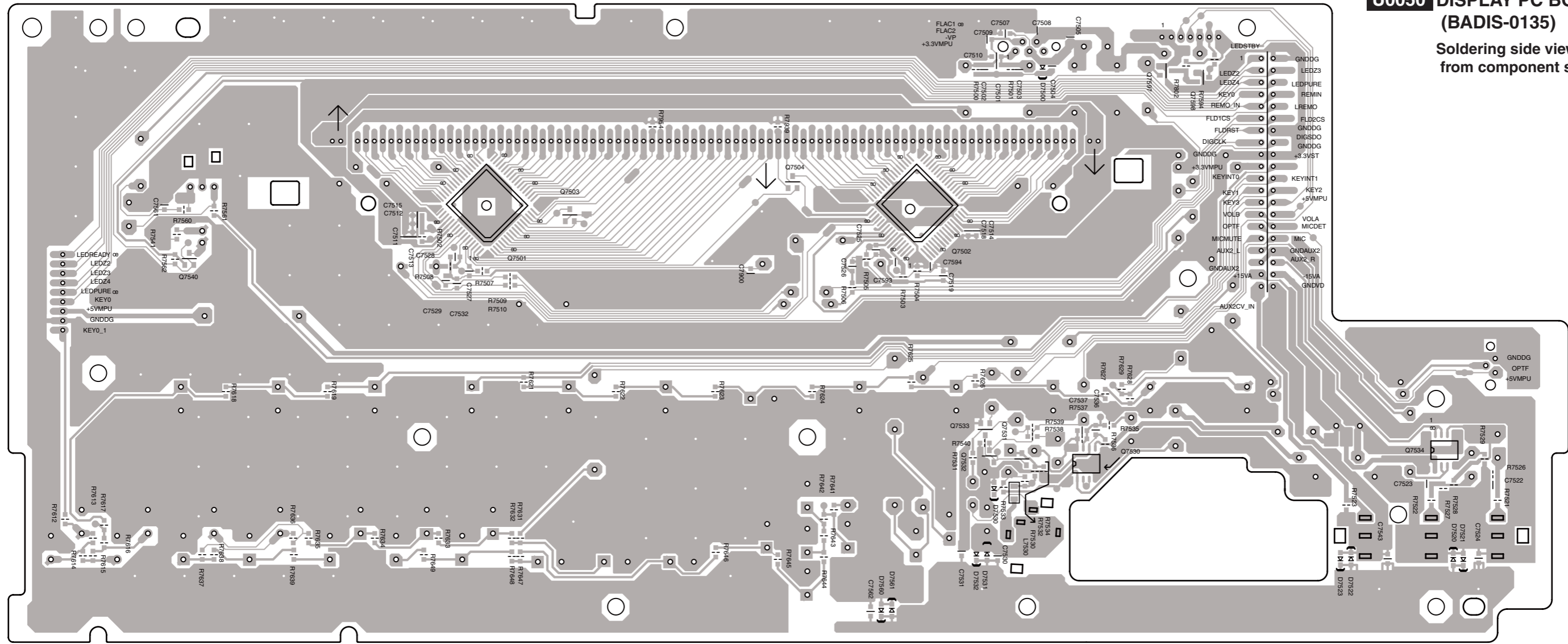

**U0054 VOLUME PC BOARD (BAETC-0139)**  
Soldering side view from component side

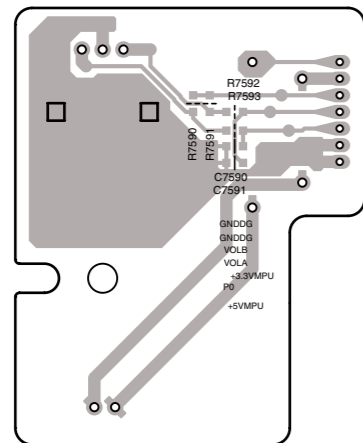

**U0052 HEADPHONE JACK PC BOARD (BAETC-0137)**  
Soldering side view from component side

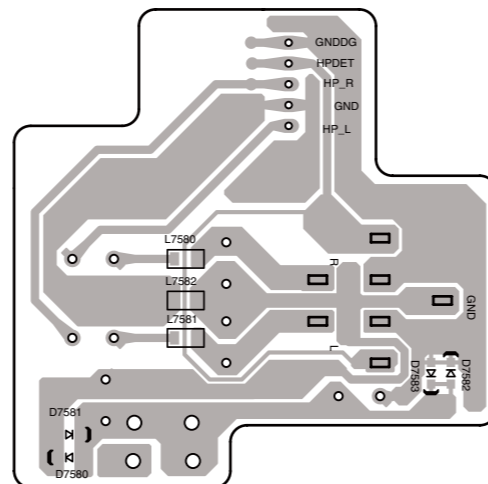

**U0051 SWITCH PC BOARD (BASW-0136)**  
Soldering side view from component side

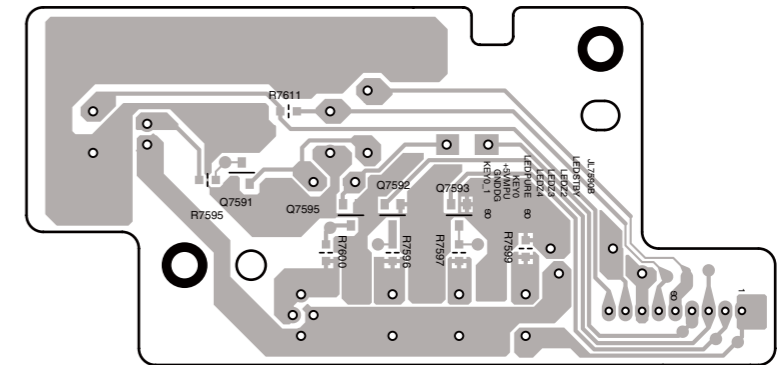

A B C D

PRINTED CIRCUIT BOARD VIEWS-13 / U005

**U0055 FUSE PC BOARD (BAPS-0140)**

1

Component side view from soldering side

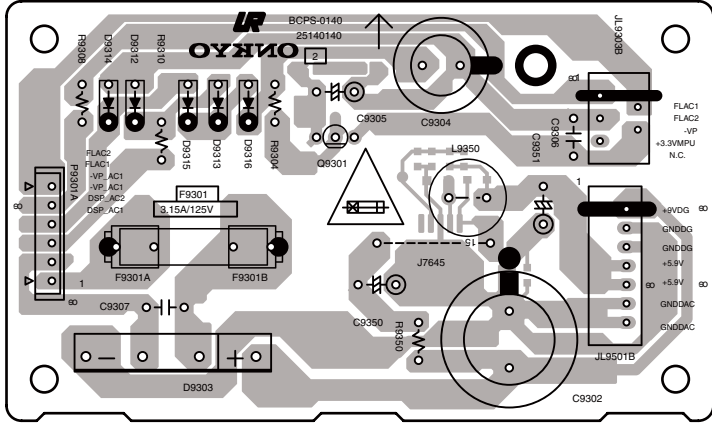

2

Soldering side view from component side

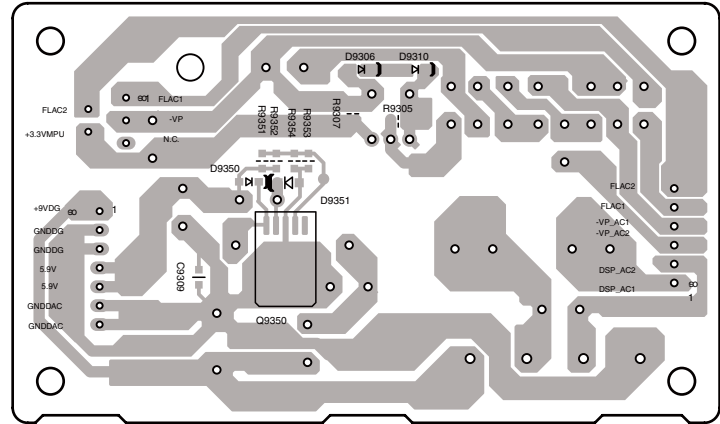

3

**U0053 FRONT OPT IN PC BOARD (BAETC-0138)**

4

Component side view from soldering side

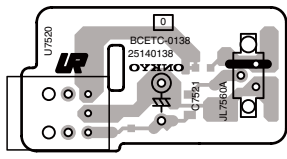

Soldering side view from component side

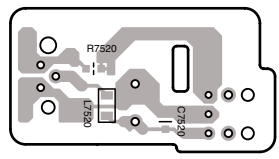

**U00510 POWER SWITCH PC BOARD (BASW-0143)**

5

Component side view from soldering side

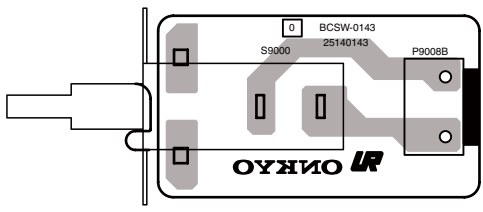

A B C D E F G H

PRINTED CIRCUIT BOARD VIEWS-14 / U006

**U0060 POWER SUPPLY & SPEAKER TERMINAL PC BOARD (BATRM-0214)**

Component side view from soldering side

1

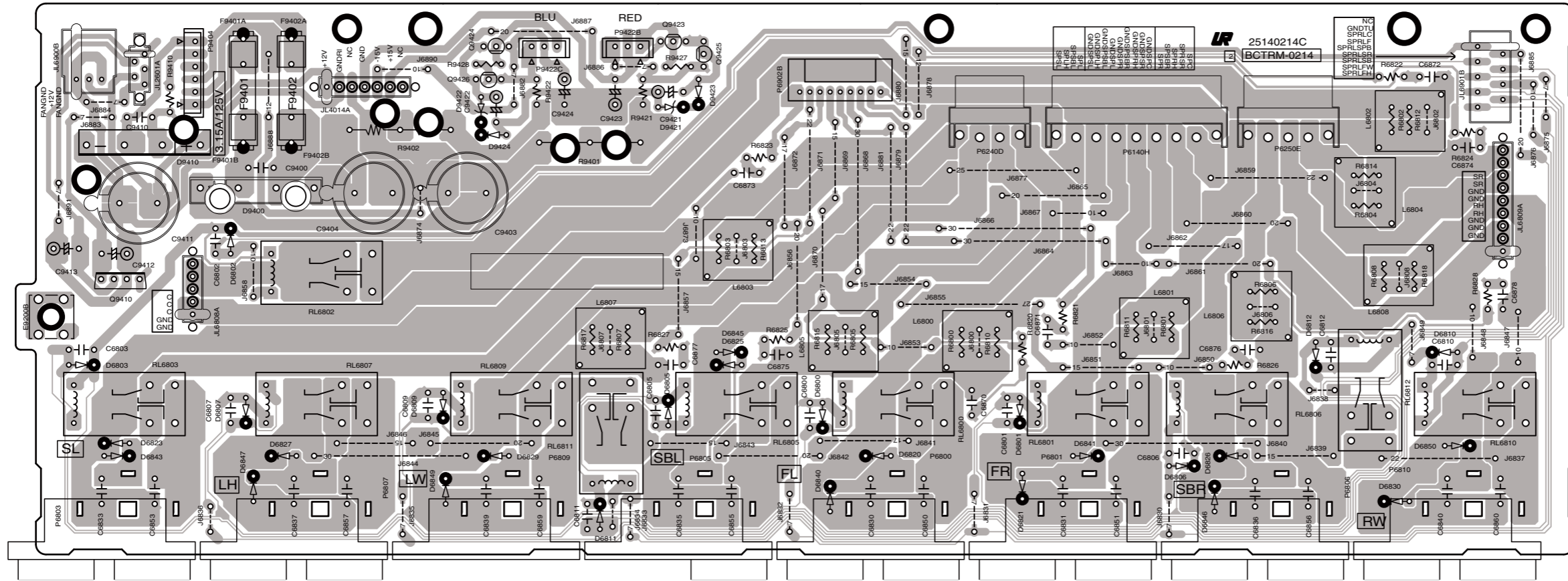

2

3

**U0062 SPEAKER TERMINAL (C) PC BOARD (BATRM-0216)**

Component side view from soldering side

4

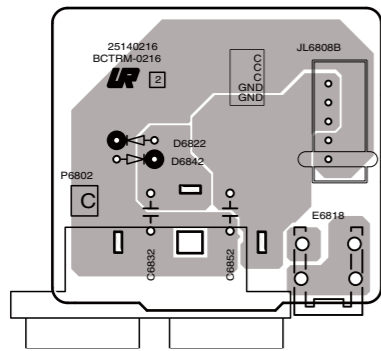

5

**U0064 INLET PC BOARD (BAPS-0218)**

Component side view from soldering side

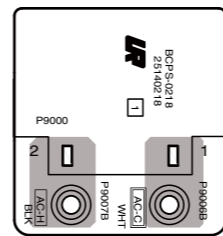

**U0065 ANALOG AUDIO POWER SUPPLY PC BOARD (BAETC-0219)**

Component side view from soldering side

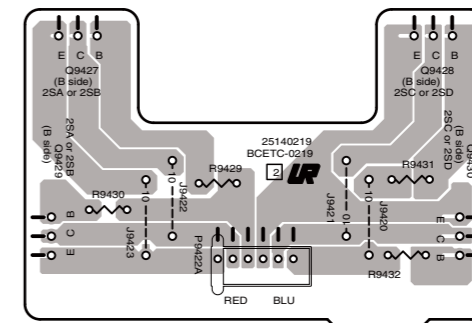

A B C D E F G H

PRINTED CIRCUIT BOARD VIEWS-15 / U006

**U0060 POWER SUPPLY & SPEAKER TERMINAL PC BOARD (BATRM-0214)**

Soldering side view from component side

1

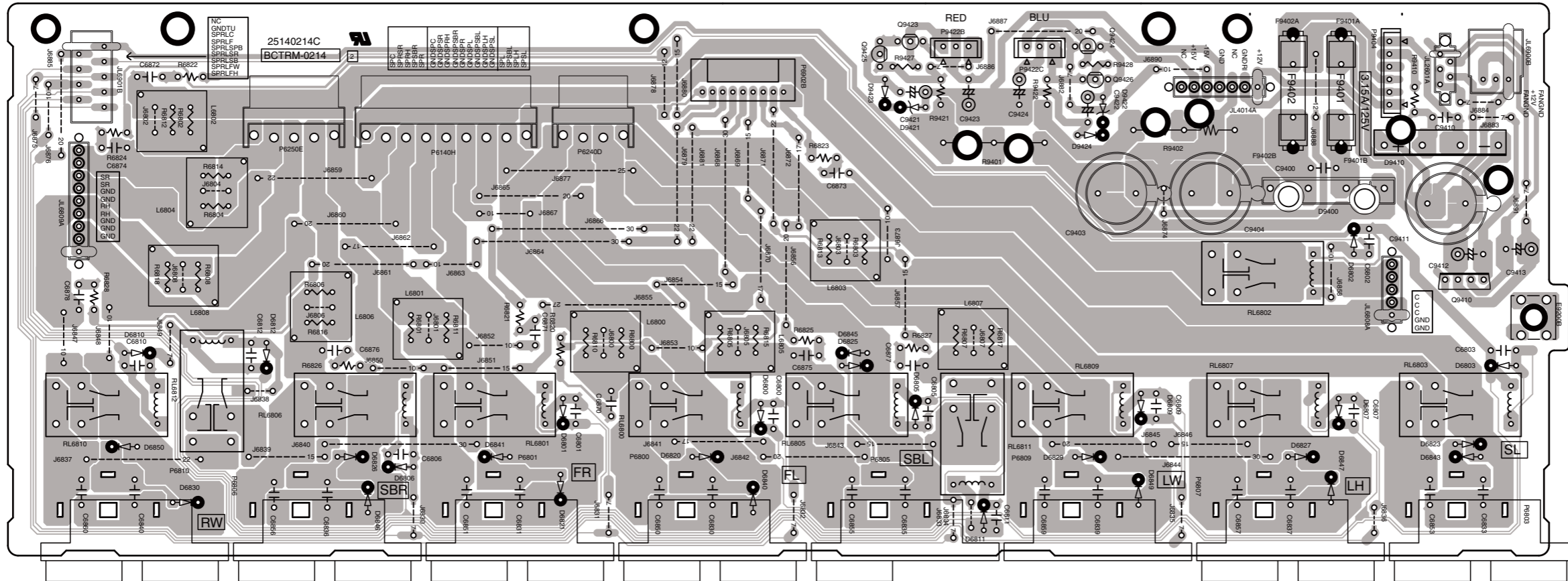

2

3

**U0062 SPEAKER TERMINAL (C) PC BOARD (BATRM-0216)**

Soldering side view from component side

4

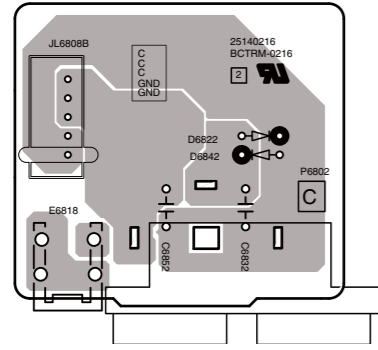

**U0064 INLET PC BOARD (BAPS-0218)**

Soldering side view from component side

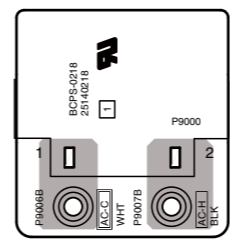

**U0065 ANALOG AUDIO POWER SUPPLY PC BOARD (BAETC-0219)**

Soldering side view from component side

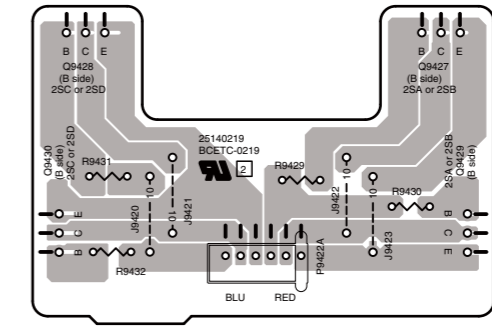

5

A B C D E F G H

PRINTED CIRCUIT BOARD VIEWS-16 / U006

**U0061 SPEAKER TERMINAL (SR/RH) PC BOARD (BATRM-0215)**

Component side view from soldering side

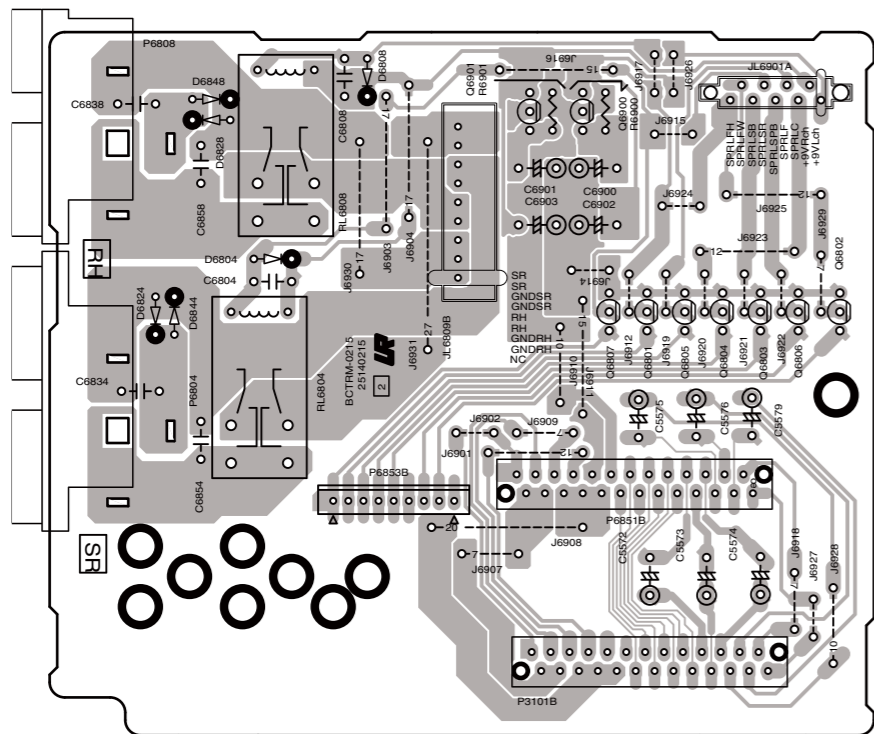

Soldering side view from component side

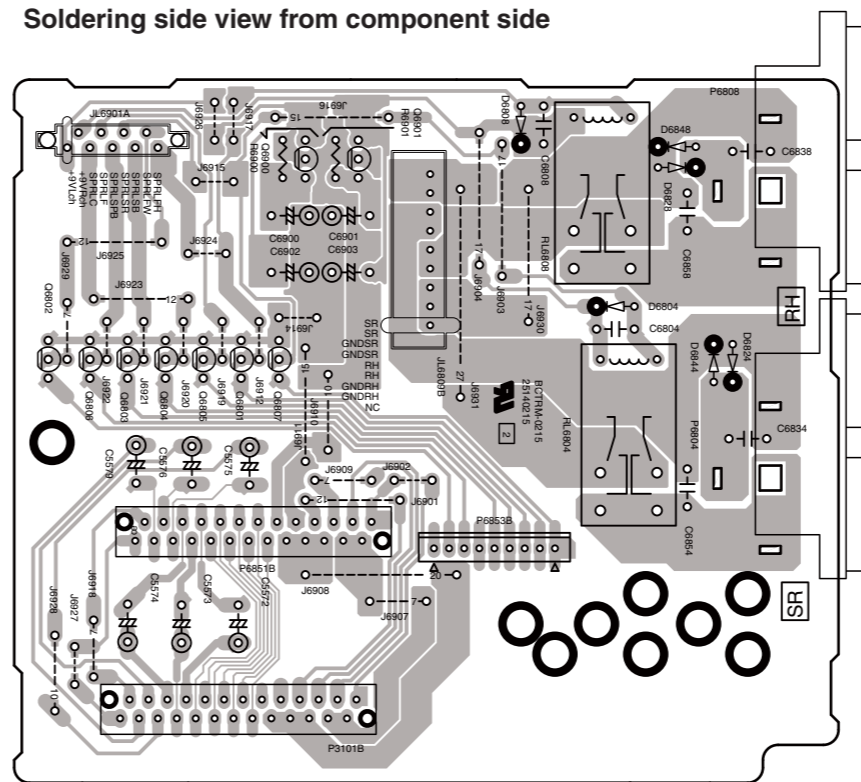

**U0063 PRIMARY POWER SUPPLY PC BOARD (BAPS-0217)**

Component side view from soldering side

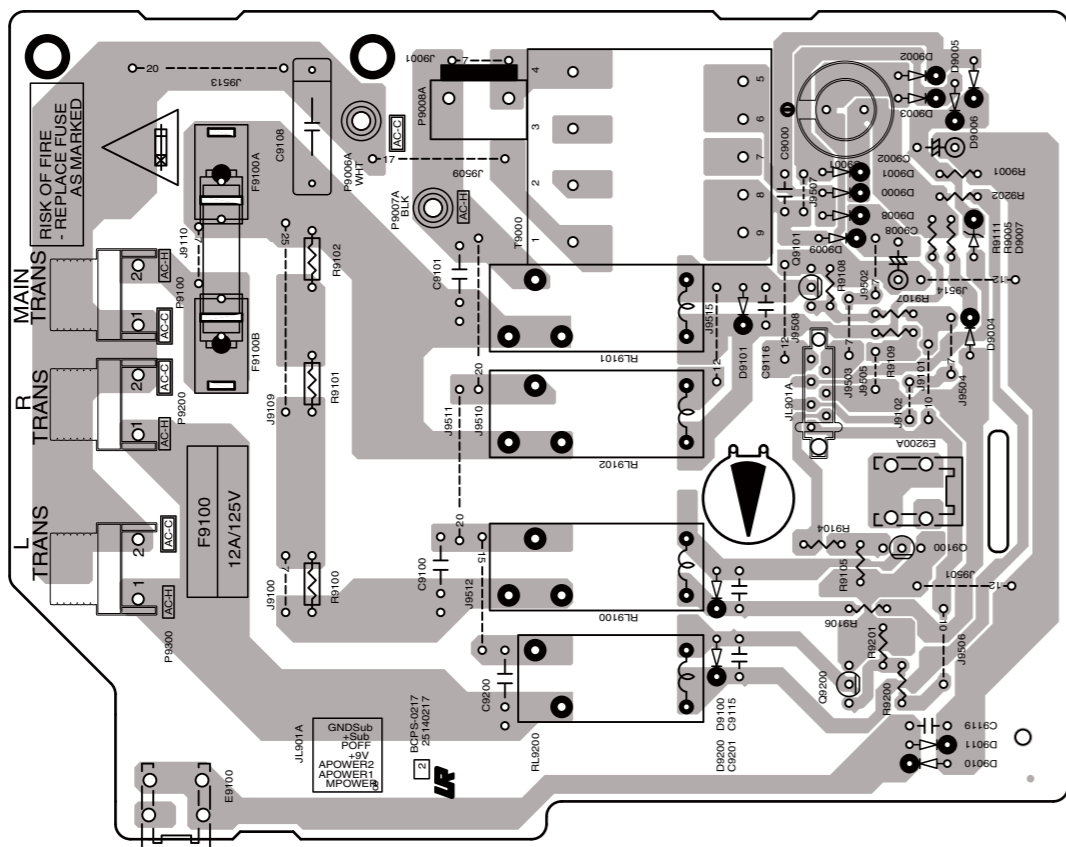

Soldering side view from component side

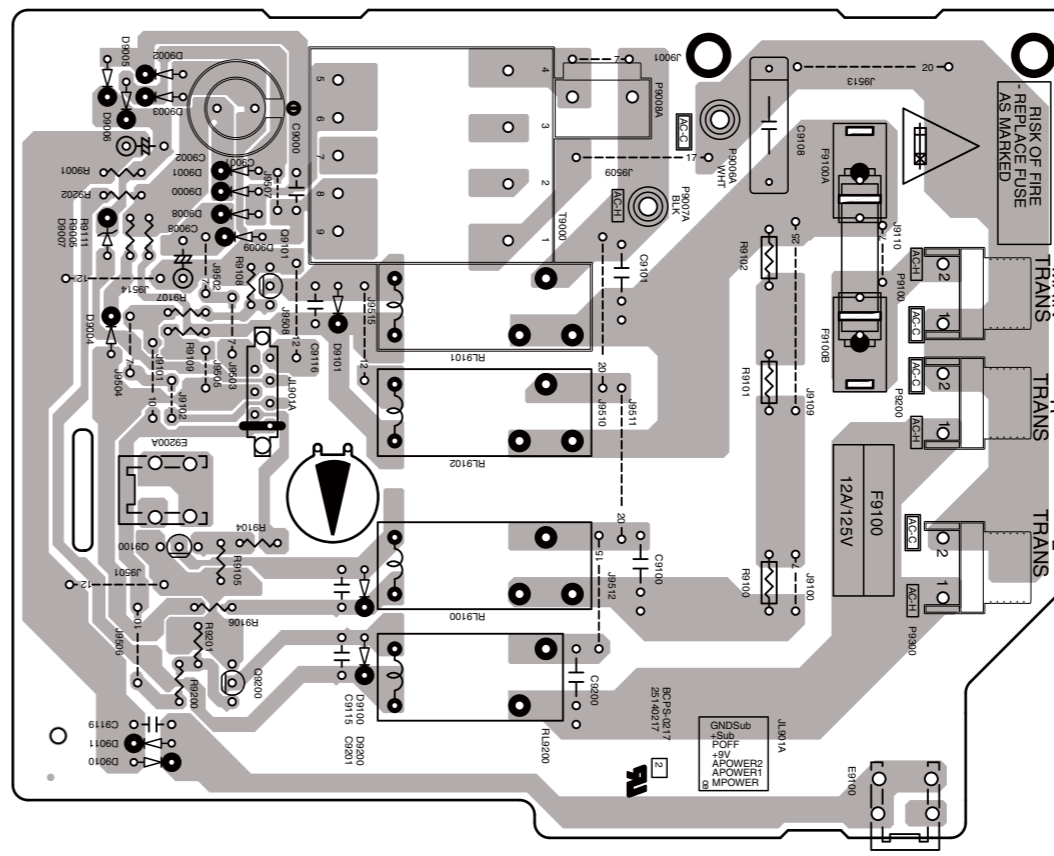

1  
2  
3  
4  
5

PRINTED CIRCUIT BOARD VIEWS-17 / U007, U010

**U007** HDMI PC BOARD (BAHDM-0157)

Component side view from soldering side

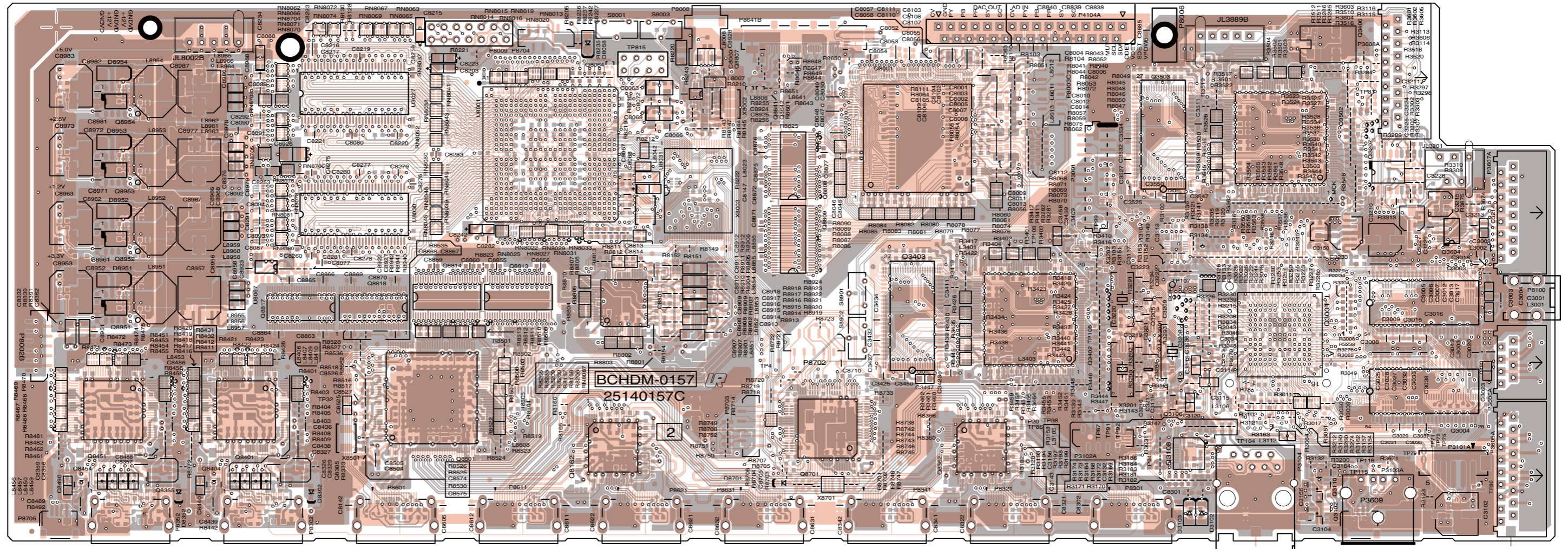

**U0101** FRONT HDMI/USB PC BOARD (BAHDM-0291)

Component side view from soldering side

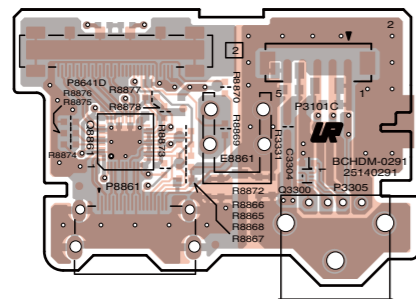

Soldering side view from component side

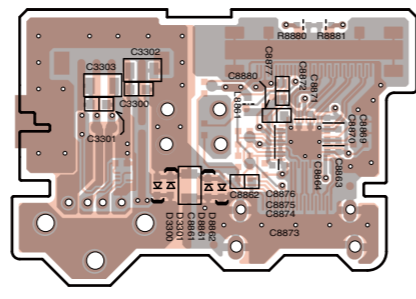



PRINTED CIRCUIT BOARD VIEWS-18 / U007, U010

**U007** HDMI PC BOARD (BAHDM-0157)

Soldering side view from component side

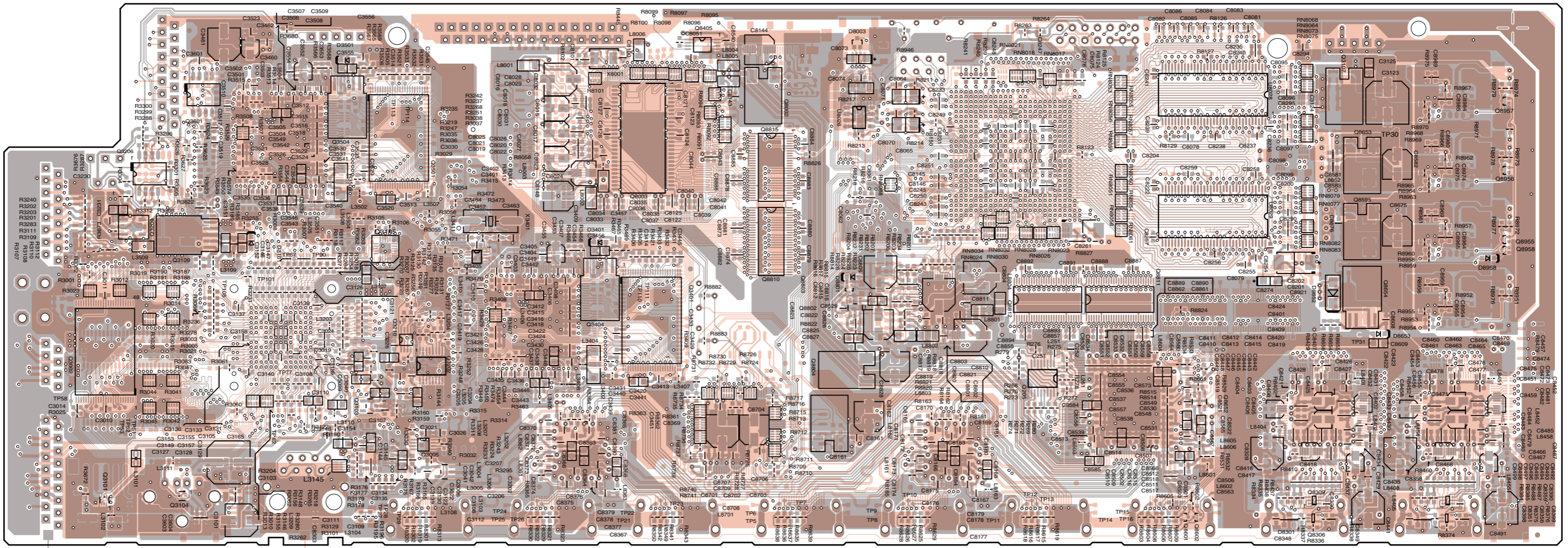

**U0101** FRONT HDMI/USB PC BOARD (BAHDM-0291)

Component side view from soldering side

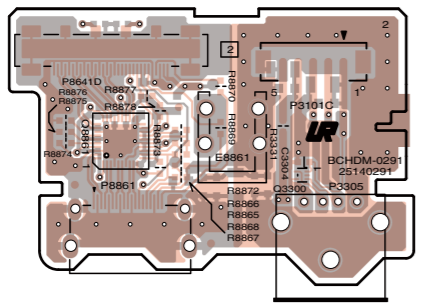

Soldering side view from component side

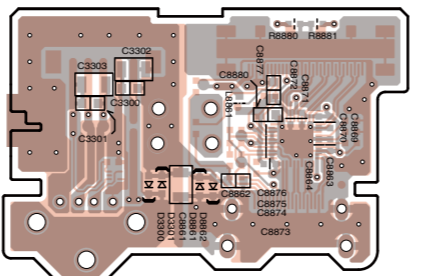

1

2

3

4

5

A B C D E F G H

PRINTED CIRCUIT BOARD VIEWS-19 / U008

U0080~U0088 AMPLIFIER PC BOARD (BACLA-0226~0234)

Component side view from soldering side

1

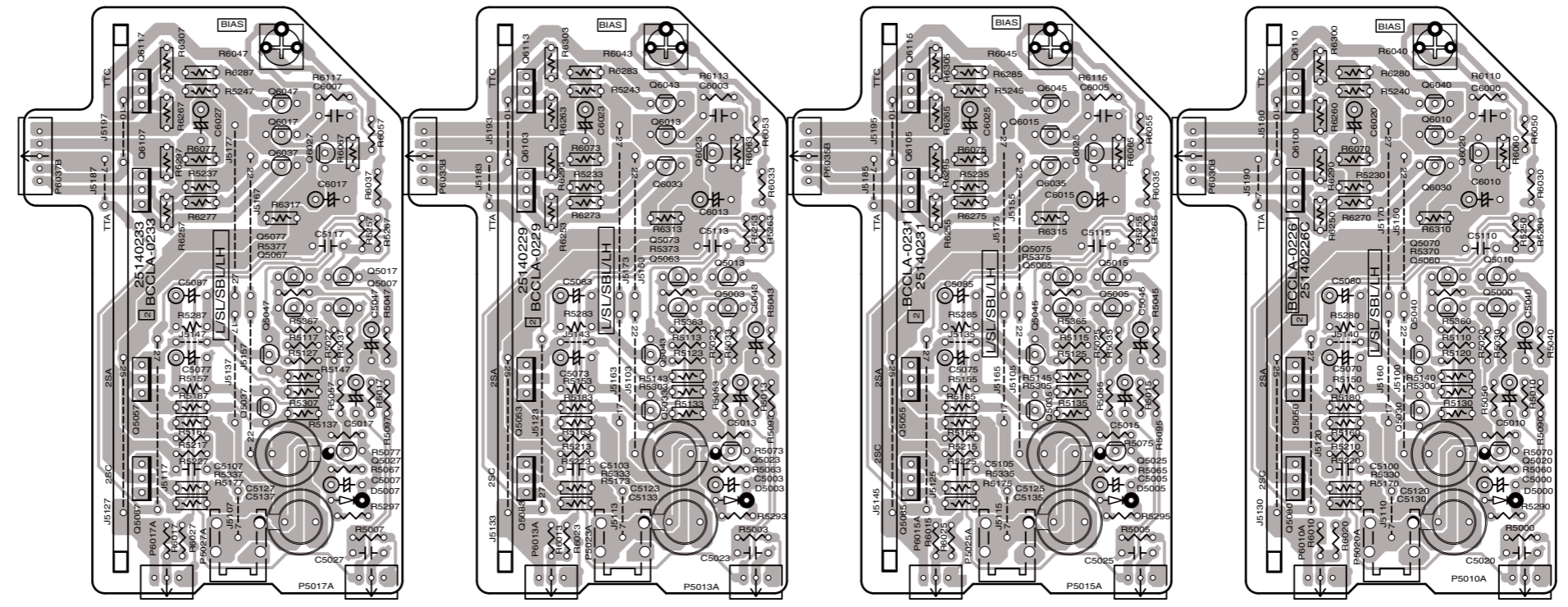

2

3

4

5

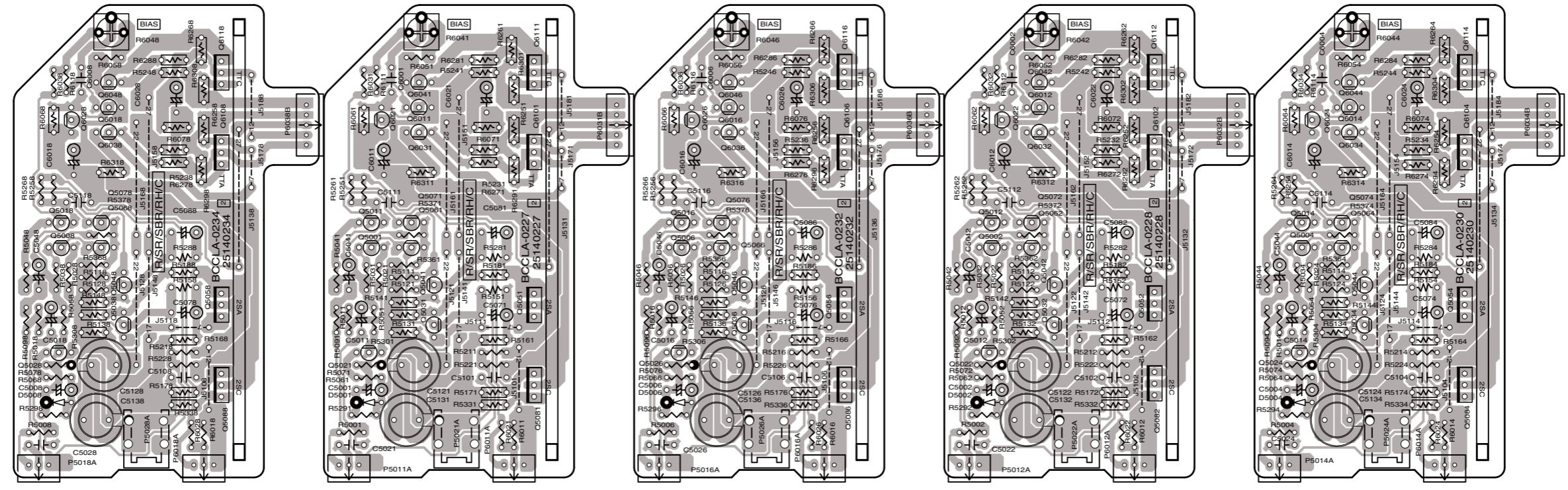

A B C D E F G H

PRINTED CIRCUIT BOARD VIEWS-20 / U008

U0080~U0088 AMPLIFIER PC BOARD (BACLA-0226~0234)

Soldering side view from component side

1

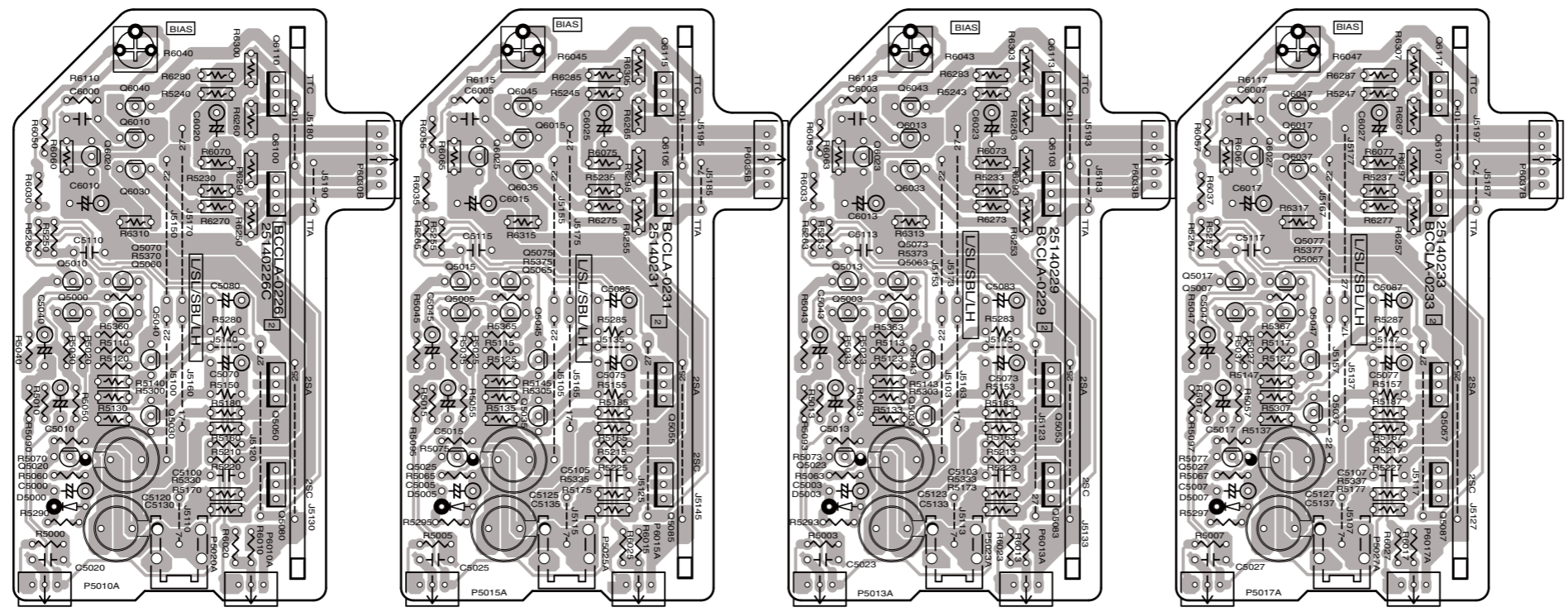

2

3

4

5

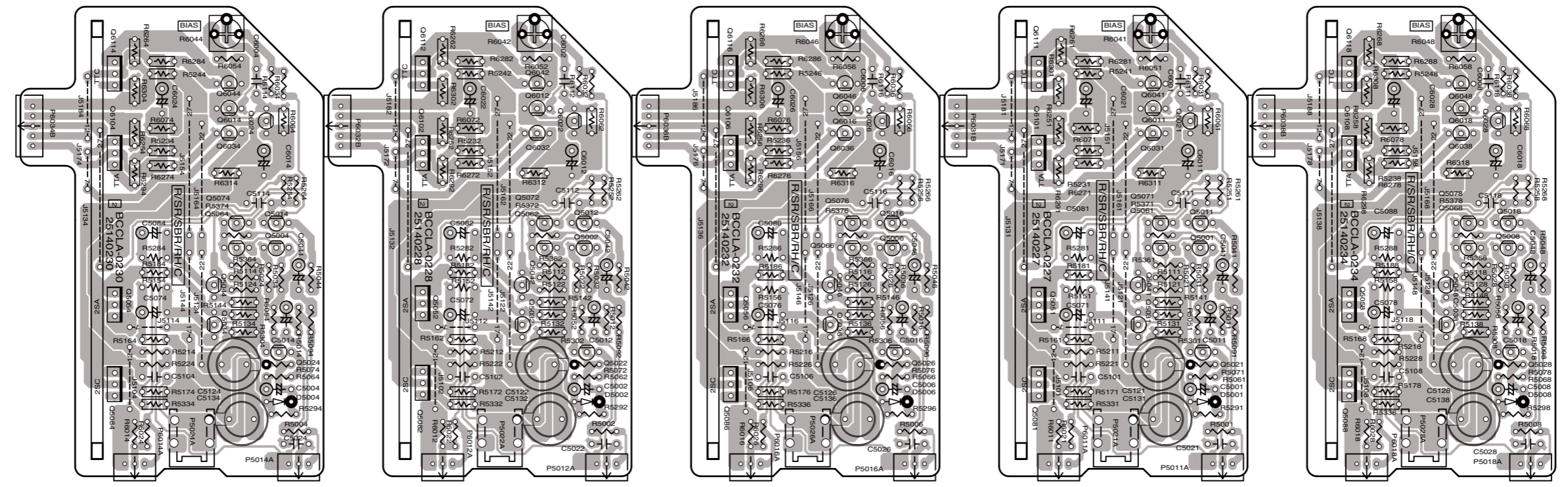

**PACKING PROCEDURE-1**

MDC type

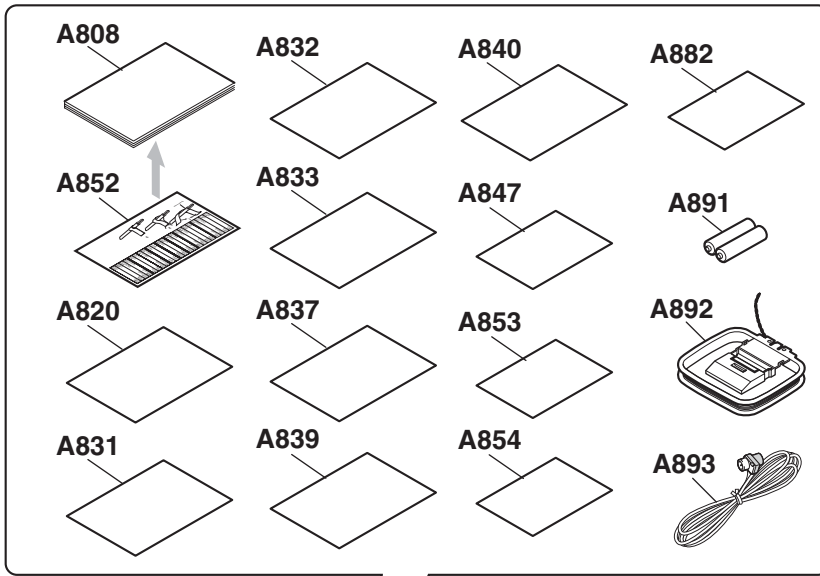

**Procedure of door section**

1. Open the Door.
2. Cushion (A616) on Front panel and fixed with the Fixlon tape (A615).
3. Close the door.
4. Door and Instsheet (A617) are fixed with the Fixlon tape (A615).

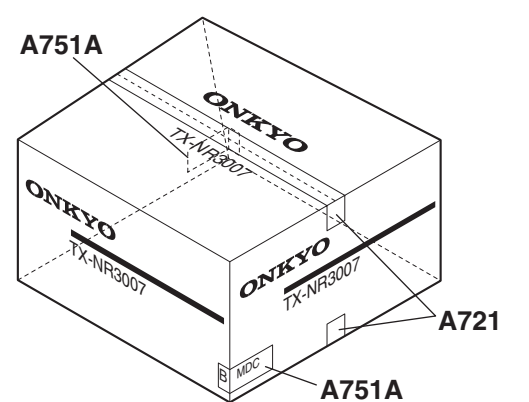
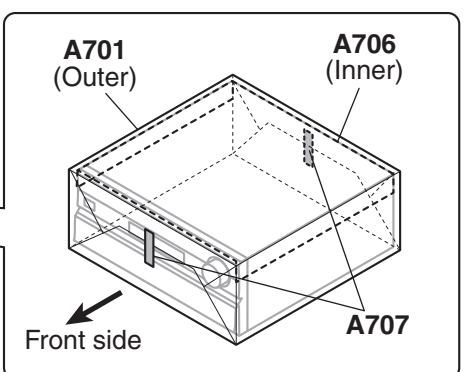
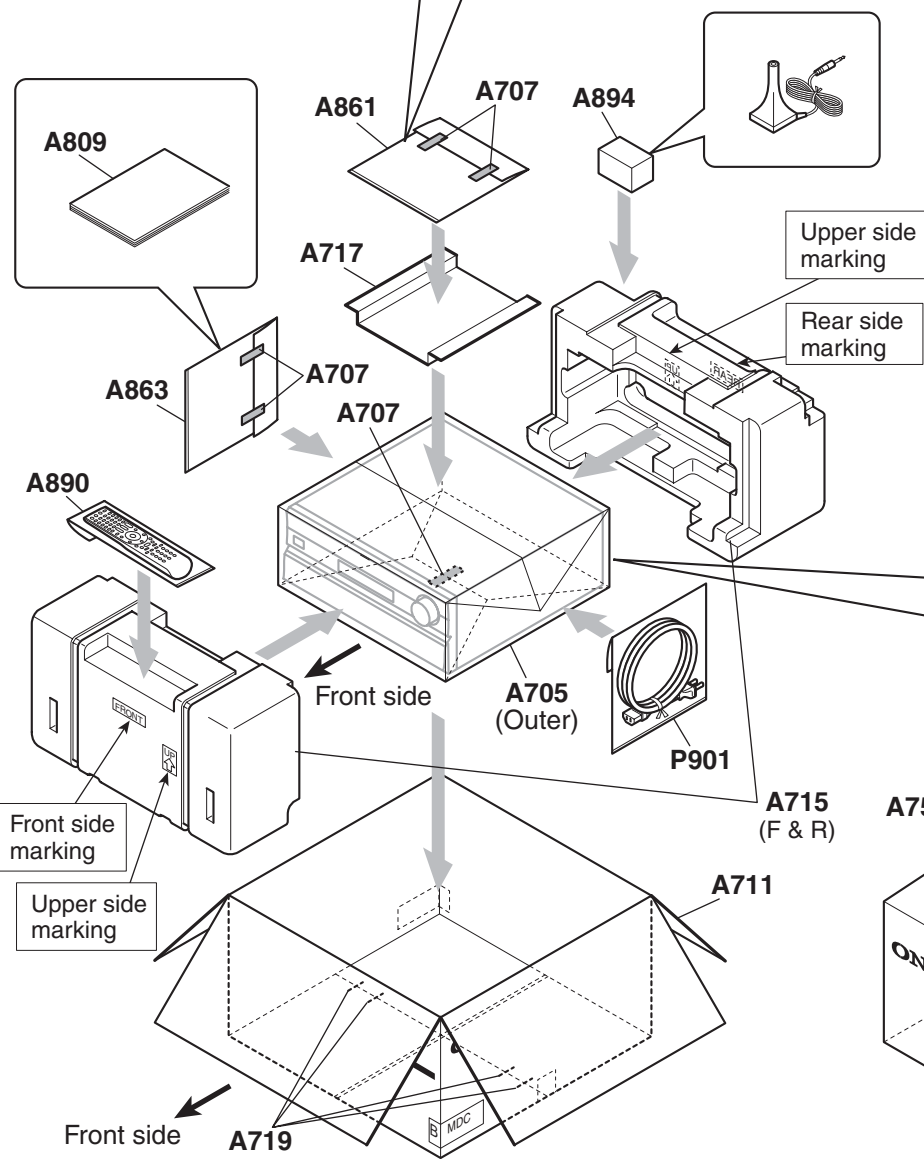
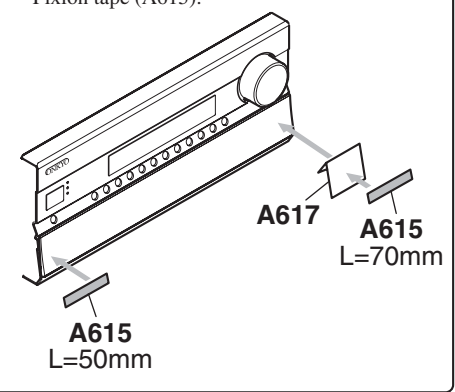
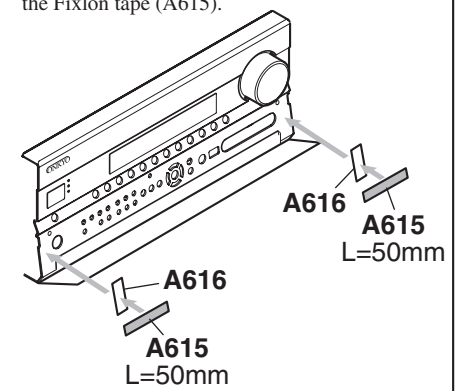

**PACKING PROCEDURE-2**

**MMP, MMO type**

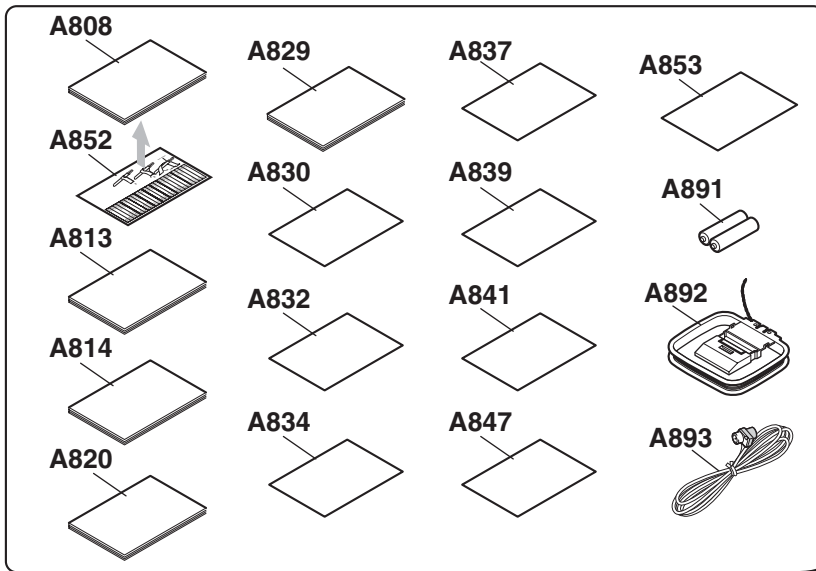

**Procedure of door section**

1. Open the Door.
2. Cushion (A616) on Front panel and fixed with the Fixlon tape (A615).
3. Close the door.
4. Door and Instsheet (A617) are fixed with the Fixlon tape (A615).

Diagram 1: Front panel with cushion A616 and tape A615 (L=50mm).

Diagram 2: Door closed with instsheet A617 and tape A615 (L=70mm).

Diagram 3: Final door assembly with tape A615 (L=50mm).

Upper side marking

Rear side marking

Front side marking

Upper side marking

Front side marking

Parts shown: A809, A861, A707, A894, P901, A717, A863, A707, A707, A890, A705 (Outer), A863, A707, A715 (F&R), A701 (Outer), A706 (Inner), A707, A810, A811, A719, A711, A751A, A721.

A701 (Outer)

A706 (Inner)

A707

Front side

A751A

A721

A751A

**TX-NR3007**

**<Note>**

Parts marked by "NSP" are generally unavailable because they are not in our Master Spare Parts List.

**NOTE : THE COMPONENTS IDENTIFIED BY THE MARK ! ARE CRITICAL FOR RISK OF FIRE AND ELECTRIC SHOCK. REPLACE ONLY WITH PART NUMBER SPECIFIED.**

**<Notes>**

- (B) : Black model
- (S) : Silver model
- <MDC> : Canadian model
- <MMP> : European model
- <MMO> : Asian model

**EXPLODED VIEW PARTS LIST**

REF. NO.	PART NAME	DESCRIPTION	Q'TY	PART NO. (SN)	REMARKS
EXPLODED	[SEMI CONDUCTOR]				
EXPLODED	Q6050 TR	TTC0002(Q)TO3PL	1	2204150	
EXPLODED	Q6050A ISO SHEET	ISO SHEET(NR5007_4CH)	1	223052	
EXPLODED	Q6051 TR	TTC0002(Q)TO3PL	1	2204150	
EXPLODED	Q6051A ISO SHEET	ISO SHEET(NR5007_5CH)	1	223051	
EXPLODED	Q6052 TR	TTC0002(Q)TO3PL	1	2204150	
EXPLODED	Q6053 TR	TTC0002(Q)TO3PL	1	2204150	
EXPLODED	Q6054 TR	TTC0002(Q)TO3PL	1	2204150	
EXPLODED	Q6055 TR	TTC0002(Q)TO3PL	1	2204150	
EXPLODED	Q6056 TR	TTC0002(Q)TO3PL	1	2204150	
EXPLODED	Q6057 TR	TTC0002(Q)TO3PL	1	2204150	
EXPLODED	Q6058 TR	TTC0002(Q)TO3PL	1	2204150	
EXPLODED	Q6060 TR	TTA0002(Q)TO3PL	1	2204140	
EXPLODED	Q6060A ISO SHEET	ISO SHEET(NR5007_4CH)	1	223052	
EXPLODED	Q6061 TR	TTA0002(Q)TO3PL	1	2204140	

EXPLODED	Q6061A	ISO SHEET	ISO SHEET(NR5007_5CH)	1	223051	
EXPLODED	Q6062	TR	TTA0002(Q)TO3PL	1	2204140	
EXPLODED	Q6063	TR	TTA0002(Q)TO3PL	1	2204140	
EXPLODED	Q6064	TR	TTA0002(Q)TO3PL	1	2204140	
EXPLODED	Q6065	TR	TTA0002(Q)TO3PL	1	2204140	
EXPLODED	Q6066	TR	TTA0002(Q)TO3PL	1	2204140	
EXPLODED	Q6067	TR	TTA0002(Q)TO3PL	1	2204140	
EXPLODED	Q6068	TR	TTA0002(Q)TO3PL	1	2204140	
EXPLODED	Q9427	TR	2SB1565-E	1	2202715	
EXPLODED	Q9427or	TR	2SA1488-Y	(1)	2203394	
EXPLODED	Q9428	TR	2SD2394-E	1	2202705	
EXPLODED	Q9428or	TR	2SC3851-Y	(1)	2203384	
EXPLODED	Q9429	TR	2SB1565-E	1	2202715	
EXPLODED	Q9429or	TR	2SA1488-Y	(1)	2203394	
EXPLODED	Q9430	TR	2SD2394-E	1	2202705	
EXPLODED	Q9430or	TR	2SC3851-Y	(1)	2203384	
EXPLODED	<b>[TRANS COIL]</b>					
EXPLODED	T901	P TRANS	NPT-1553D	1	2301893	!, <MDC>
EXPLODED	T901	P TRANS	NPT-1553M	1	2301894	!, <MMO, MMP>
EXPLODED	T903	P TRANS	NPT-1581D	1	2301952	!, <MDC>
EXPLODED	T903	P TRANS	NPT-1581M	1	2301953	!, <MMO, MMP>
EXPLODED	T904	P TRANS	NPT-1582D	1	2301955	!, <MDC>
EXPLODED	T904	P TRANS	NPT-1582M	1	2301956	!, <MMO, MMP>
EXPLODED	<b>[SW TRM]</b>					
EXPLODED	F2001	FUSE	4A-UL/T-233	1	252325GR	!
EXPLODED	F2001 or	FUSE	4A-T/UL-ST2	(1)	252257GR	!
EXPLODED	F2004	FUSE	1.25A-UL/T-233	1	252318GR	!
EXPLODED	F2004 or	FUSE	1.25A-T/UL-ST2	(1)	252251GR	!
EXPLODED	F2005	FUSE	1.25A-UL/T-233	1	252318GR	!
EXPLODED	F2005 or	FUSE	1.25A-T/UL-ST2	(1)	252251GR	!
EXPLODED	F6601	FUSE	20A-UL-250V	1	252304GR	!
EXPLODED	F6602	FUSE	20A-UL-250V	1	252304GR	!
EXPLODED	F6603	FUSE	20A-UL-250V	1	252304GR	!

EXPLODED	F6604	FUSE	20A-UL-250V	1	252304GR	!
EXPLODED	F9100	FUSE	12A-UL-ST6	1	252340GR	!, <MDC>
EXPLODED	F9100	FUSE	6.3A-SE-EAK FUSE	1	252079GR	!, <MMO, MMP>
EXPLODED	F9100 or	FUSE	6.3A-SE-TL250V	(1)	252279GR	!, <MMO, MMP>
EXPLODED	F9301	FUSE	3.15A-UL/T-233	1	252323GR	!
EXPLODED	F9301 or	FUSE	3.15A-T/UL-ST2	(1)	252256GR	!
EXPLODED	F9401	FUSE	3.15A-UL/T-233	1	252323GR	!
EXPLODED	F9401 or	FUSE	3.15A-T/UL-ST2	(1)	252256GR	!
EXPLODED	F9402	FUSE	3.15A-UL/T-233	1	252323GR	!
EXPLODED	F9402 or	FUSE	3.15A-T/UL-ST2	(1)	252256GR	!
EXPLODED	JL4103	JMP LEAD	JL5 550H	1	---	NSP
EXPLODED	P061	FAN	D09A-12PG13	1	24502328	
EXPLODED	P062	FAN	D09A-12PG13	1	24502328	
EXPLODED	P106	FFC	NCFC7-111012	1	2047111012	
EXPLODED	P3101	SOCKET AS	NSAS-10P1813	1	2009991173UL	
EXPLODED	P4008	FFC	NCFC7-090512	1	2047090512	
EXPLODED	P4009	FFC	NCFC7-150512	1	2047150512	
EXPLODED	P4104	FFC	NCFC7-311012	1	2047311012	
EXPLODED	P7501	SOCKET AS	NSAS-80P1788	1	2009991154UL	
EXPLODED	P8641	FFC	NCFC7-31007	1	204D31007	
EXPLODED	P9008	SOCKET AS	NSAS-6P1675	1	2009991073UL	<MMO, MMP>
EXPLODED	[CHASSIS SCREW]					
EXPLODED	A001	HEAT SINK	(5)	1	27160634	
EXPLODED	A003	HEAT SINK	(4)	1	27160635	
EXPLODED	A005	SPACER	(PC)	8	27270485	
EXPLODED	A007	SCREW	3P+6FN(3BC)	8	82143006GR	
EXPLODED	A009	SCREW	3SMS8W.SW+14B(CU)	18	801634	
EXPLODED	A011	RETAINER	(HS-2)	2	27141530A	
EXPLODED	A013	SCREW	3TTB+8B(3CM)SR	4	801637	
EXPLODED	A017	RETAINER	(HS-C)	1	27142151	
EXPLODED	A019	SCREW	3TTB+8B(3CM)SR	8	801637	
EXPLODED	A021	RETAINER	(HS-L)	1	27142152	
EXPLODED	A023	SCREW	3TTB+8B(3CM)SR	4	801637	



EXPLODED	A025	HOLDER	(CLUMP) UA-0	1	27190432	
EXPLODED	A027	HOLDER	WS-4NS	1	27191207	
EXPLODED	A029	RETAINER	(HS-R)	1	27142153A	
EXPLODED	A031	SCREW	3TTB+8B(3CM)SR	4	801637	
EXPLODED	A033	HOLDER	(CLUMP) UA-0	1	27190432	
EXPLODED	A037	SCREW	3TTB+8B(3CM)SR	4	801637	
EXPLODED	A039	SCREW	3TTB+8B(3CM)SR	9	801637	
EXPLODED	A041	HEAT SINK(S)	240	1	27160608	
EXPLODED	A043	SCREW	3TTB+8B(3CM)SR	3	801637	
EXPLODED	A045	SCREW	3TTB+8B(3CM)SR	2	801637	
EXPLODED	A049	IB CUSHION	W15 x 3t TAPE	1	28141585	
EXPLODED	A053	CHASSIS	(SUB)	1	27100536B	
EXPLODED	A055	RETAINER	(FBR)	1	27142150A	
EXPLODED	A057	SCREW	3TTB+8B(3CM)SR	3	801637	
EXPLODED	A061	HOLDER	SPM-4	4	27191154	
EXPLODED	A062	BUSHING	CE-016 L=25	1	28170097	
EXPLODED	A064	BUSHING	L125	1	28170004	<MMO, MMP>
EXPLODED	A065	BUSHING	---	1	28170070	
EXPLODED	A067	HOLDER	KGPS-14RF	1	27190802	
EXPLODED	A069	BRACKET	(FAN-L)	1	27131022A	
EXPLODED	A071	HOLDER	(FAN)	4	27191307	
EXPLODED	A073	BRACKET	(SUB-L)	1	27131060	
EXPLODED	A075	SCREW	3TTB+8B(3CM)SR	3	801637	
EXPLODED	A077	HOLDER	WS-4NS	2	27191207	
EXPLODED	A079	BRACKET	(FAN-R)	1	27131023A	
EXPLODED	A081	HOLDER	(FAN)	4	27191307	
EXPLODED	A083	BRACKET	(SUB-R)	1	27131061	
EXPLODED	A085	SCREW	3TTB+8B(3CM)SR	3	801637	
EXPLODED	A087	HOLDER	WS-4NS	1	27191207	
EXPLODED	A117	SCREW	4TTC+8C(3BC)	4	830440089GR	
EXPLODED	A119	SCREW	4TTC+8C(3BC)	4	830440089GR	
EXPLODED	A121	SPACER	---	4	27270489	
EXPLODED	A125	SCREW	3TTB+8B(3CM)SR	8	801637	

EXPLODED	A126	SCREW	3TTB+8B(3CM)SR	8	801637
EXPLODED	A127	CUSHION	t10 x 10 x 100	1	28141746
EXPLODED	A131	HEAT SINK	(SP)	1	27160643
EXPLODED	A133	SPACER	t0.5 x w30 x d10	1	27270495
EXPLODED	A135	SPACER	t0.5 x w13 x d5	1	27270514
EXPLODED	A137	SCREW	3TTB+8B(3CM)SR	4	801637
EXPLODED	A139	SCREW	3TTB+8B(3BC)	2	838430088GR
EXPLODED	A141	TAPE	(CLOTH-16U)	1	29110083
EXPLODED	A147	CUSHION	(BUTYL)	1	28141748
EXPLODED	A151	CHASSIS	---	1	27100545B
EXPLODED	A153	LEG	---	4	27175419
EXPLODED	A155	CUSHION	(LEG)	4	28141735
EXPLODED	A157	IB CUSHION	W15 x 3t TAPE	1	28141585
EXPLODED	A159	CUSHION	---	8	28141637
EXPLODED	A161	SCREW	3TTB+8B(3CM)SR	4	801637
EXPLODED	A163	HOLDER	(SPD-6)	4	27191308
EXPLODED	A165	HOLDER	KGPS-10RF	3	27190813
EXPLODED	A167	HOLDER	KGLS-10RT	1	27190428A
EXPLODED	A169	HOLDER	KGLS-12RT	1	27190266
EXPLODED	A170	HOLDER	KGLS-22RT	1	27190772
EXPLODED	A171	HOLDER	KGLS-20RT V0	3	27191338
EXPLODED	A173	HOLDER	HOLDER KGLS-18S	1	27190470
EXPLODED	A175	HOLDER	KGPS-18S	1	27191339
EXPLODED	A177	HOLDER	KGLS-14S	1	27190164
EXPLODED	A179	HOLDER	SPM-4	1	27191154
EXPLODED	A181	HOLDER	KGLS-22RT	3	27190772
EXPLODED	A183	HOLDER	HOLDER KGLS-18S	1	27190470
EXPLODED	A185	HOLDER	KGLS-22RT	1	27190772
EXPLODED	A187	SCREW	3TTB+8B(3CM)SR	1	801637
EXPLODED	A189	SCREW	3TTB+8B(3CM)SR	1	801637
EXPLODED	A191	SCREW	3TTB+8B(3CM)SR	1	801637
EXPLODED	A193	SCREW	3TTB+8B(3CM)SR	1	801637
EXPLODED	A195	SCREW	3TTB+8B(3BC)	2	838430088GR

EXPLODED	A197	SCREW	3TTB+8B(3BC)	3	838430088GR	
EXPLODED	A199	SCREW	3TTB+8B(3BC)	2	838430088GR	
EXPLODED	A200	SCREW	4TTC+8C(3BC)	1	830440089GR	
EXPLODED	A203	SCREW	3TTB+8B(3CM)SR	8	801637	
EXPLODED	A205	SCREW	3TTB+8B(3CM)SR	8	801637	
EXPLODED	A215	TAPE	(CLOTH-8U)	1	29110082	
EXPLODED	A221	CUSHION	(t19.5 x 20 x 10)	2	28141826	
EXPLODED	A223	CUSHION	(PCB)	2	28141789	
EXPLODED	A247	LABEL	(PT)	1	29363379-1	
EXPLODED	A251	WIRE TIE	BSK-1	23	260208	
EXPLODED	A255	REAR PANEL	3007DC/DF	1	27124029A	N <MDC>
EXPLODED	A255	REAR PANEL	3007MP/MO	1	27124030A	N <MMO, MMP>
EXPLODED	A261	SCREW	3TTB+8B(3BC)	52	838430088GR	
EXPLODED	A263	SPACER	---	1	27270489	
EXPLODED	A279	SCREW	3P+6FN(3BC)	10	82143006GR	<MMO, MMP>
EXPLODED	A279	SCREW	3P+6FN(3BC)	11	82143006GR	<MDC>
EXPLODED	A285	SCREW	4TTB+10B(3BC)	2	838440108GR	
EXPLODED	A287	TRM	E TERMINAL	1	25060151	
EXPLODED	A289	WASHER	W3 x 10F(3BC)	1	87643010GR	
EXPLODED	A291	LABEL	(SP1)	1	29390790	
EXPLODED	A293	LABEL	(SP2)	1	29390791	
EXPLODED	A295	ISO PLT	(HS-R)	2	28175336A	
EXPLODED	A296	RIVET	NRP-345	1	880009	
EXPLODED	A297	P RIVET	P-3055B-8L	2	880048	
EXPLODED	A298	ISO PLT	(HS-U)	1	28175337A	
EXPLODED	A299	SCREW	3TTB+8B(3CM)SR	2	801637	
EXPLODED	P6800	P RIVET	JB-407A-C	22	880052	<MMO, MMP>
EXPLODED	<b>[CABINET]</b>					
EXPLODED	A301	F BRACKET	AS(BLACK)	1	27111561E	
EXPLODED	A301	F BRACKET	AS(SILVER)	1	27111562E	
EXPLODED	A303	B PLATE	(B)	1	28133428	
EXPLODED	A303	B PLATE	(S)	1	28133429	
EXPLODED	A311	KNOB	(STBY)807	1	28326702	(S)

EXPLODED	A307	FACET	(VOL)	1	28200040A	
EXPLODED	A309	SCREW	3TTB+8B(3CM)SR	2	801637	
EXPLODED	A313	IB CUSHION	W15 x 3t TAPE	1	28141585	
EXPLODED	A315	KNOB	(SEL)	2	28326725A	N (S)
EXPLODED	A317	GUIDE	(SEL)B	2	27268229	N (B)
EXPLODED	A317	GUIDE	(SEL)S	2	27268230	N (S)
EXPLODED	A319	SCREW	3TTB+8B(3CM)SR	21	801637	
EXPLODED	A321	RETAINER	(F)	1	27142155A	
EXPLODED	A323	KNOB	(PURE)AS 5007B	1	28326717A	N (B)
EXPLODED	A323	KNOB	(PURE)AS 5007S	1	28326718B	N (S)
EXPLODED	A327	BUSHING	(DOOR)	2	28170095	(B)
EXPLODED	A327	BUSHING	(DOOR) GRAY	2	28170096	(S)
EXPLODED	A329	RETAINER AS	(L)	1	27142166	
EXPLODED	A331	RETAINER AS	(R)	1	27142167	
EXPLODED	A333	SCREW	3TTB+8B(3BC)	3	838430088GR	
EXPLODED	A337	HOLDER	(DAMPER)	1	27191334B	
EXPLODED	A339	SCREW	3TTB+8B(3BC)	1	838430088GR	
EXPLODED	A341	DAMPER	002P Type-L	1	27301965	
EXPLODED	A343	SCREW	3TTB+8B(3BC)	1	838430088GR	
EXPLODED	A345	PLATE	(LOCK)	1	27262843	
EXPLODED	A347	SCREW	3P+6FN(3BC)	2	82143006GR	
EXPLODED	A349	BRACKET	(L)	1	27131062B	
EXPLODED	A351	BRACKET	(R)	1	27131063B	
EXPLODED	A353	SCREW	3P+6FN(3BC)	2	82143006GR	
EXPLODED	A361	E-WASHER	ES-3S	1	8930301S	
EXPLODED	A363	SCREW	3TTB+8B(3CM)SR	3	801637	
EXPLODED	A365	SCREW	3TTB+8B(3CM)SR	1	801637	
EXPLODED	A367	SCREW	3TTB+8B(3BC)	3	838430088GR	
EXPLODED	A369	SCREW	3TTB+8B(3BC)	3	838430088GR	
EXPLODED	A371	SCREW	3TTB+10B(3BC)	1	838430108GR	
EXPLODED	A401	F PANEL	5007(B)DC/DF	1	27213267	(B) <MDC>
EXPLODED	A401	F PANEL	5007(B)MP	1	27213268	(B) <MMO, MMP>
EXPLODED	A401	F PANEL	5007(S)MP	1	27213269	(S)

EXPLODED	A403	BADGE	BADGE	1	28135244	(B)
EXPLODED	A403	BADGE	---	1	28135298	(S)
EXPLODED	A404	CLEAR PLT	(AS) NR3007	1	28192269	N
EXPLODED	A405	KNOB	(VOL)AS 1007B	1	28326696A	(B)
EXPLODED	A405	KNOB	(VOL)AS 1007S	1	28326697A	(S)
EXPLODED	A406	CUSHION	---	1	28141528GR	
EXPLODED	A407	DOOR	SR3007(B)MDC	1	28148740	N (B) <MDC>
EXPLODED	A407	DOOR	SR3007(B)MMP/MO	1	28148741	N (B) <MMO, MMP>
EXPLODED	A407	DOOR	SR3007(S)MMP	1	28148742	N (S)
EXPLODED	A411	KNOB	(POW) (B)	1	28326454	(B) <MMO, MMP>
EXPLODED	A411	KNOB	(POW)(S) 09	1	28326729	(S)
EXPLODED	A413	SCREW	3P+6FN(3BC)	2	82143006GR	<MMO, MMP>
EXPLODED	A415	SCREW	3TTB+8B(3CM)SR	2	801637	<MMO, MMP>
EXPLODED	A551	COVER	(B) (Bent)	1	28210040A	(B)
EXPLODED	A551	COVER	(B) (Not Bent)	1	28210040AZ	(B)
EXPLODED	A551	COVER	(S) (Bent)	1	28210041A	(S)
EXPLODED	A553	LABEL	(CAUTION)	1	29363797	(S)
EXPLODED	A553	LABEL	(COVER)	1	29364123	(B)
EXPLODED	A555	ST SCREW	4TTB+8C(NI)	6	838240089	(S)
EXPLODED	A555	SCREW	4TTB+8C(3BC)	6	838440089GR	(B)
EXPLODED	A557	SCREW	3TTB+8B(3BC)	3	838430088GR	(B)
EXPLODED	A561	LABEL	HOOKUP-ONKYO	1	29363194	<MDC>
EXPLODED	A694	CUSHION	(FNP) t25x15x10	1	28141828	
EXPLODED	<b>[TUNER UNIT]</b>					
EXPLODED	<b>U001</b>	<b>U0010 + U0011 + U0012 + U0013 + U0014</b>	<b>BAAF-0180-1A *</b>	<b>1</b>	<b>1B234580-1A</b>	N
EXPLODED	U0010	POWER SUPPLY PC board ass'y	BAAF-0180-1A	1	1B2345180-1A	N
EXPLODED	U0011	DIODE PC board ass'y	BAPS-0181-1A	1	1B2345181-1A	N
EXPLODED	U0012	RELAY PC board ass'y	BAPS-0182-1A	1	1B2345182-1A	N
EXPLODED	U0013	THERMAL SENSOR PC board ass'y	BAETC-0183-1A	1	---	N NSP
EXPLODED	U0014	THERMAL SENSOR PC board ass'y	BAETC-0184-1A	1	---	N NSP
EXPLODED	<b>U002</b>	<b>U0020 + U0021</b>	<b>BAAMP-0191-1A *</b>	<b>1</b>	<b>1B234591-1A</b>	N
EXPLODED	U0020	AMPLIFIER PC board ass'y (C,SR,RH,SBR,R)	BAAMP-0191-1A	1	1B2345191-1A	N
EXPLODED	U0021	AMPLIFIER PC board ass'y (L,SBL,LH,SL)	BAAMP-0192-1A	1	1B2345192-1A	N

EXPLODED	<b>U003</b>	<b>U0030 + U0031</b>	<b>BAASP-0202-1D *</b>	<b>1</b>	<b>1B234502-1D</b>	N
EXPLODED	U0030	ANALOG AUDIO PC board ass'y	BAASP-0202-1D	1	1B2345202-1D	N
EXPLODED	U0031	ANALOG VIDEO PC board ass'y	BAVD-0203-1D	1	1B2345203-1D	N
EXPLODED	<b>U004</b>	<b>U0040 + U0041 + U0041 + U0043 + U0044</b>	<b>BADG-0208-1A *</b>	<b>1</b>	<b>1B234508-1A</b>	N <MDC>
EXPLODED	<b>U004</b>	<b>+ U0045 + U0046</b>	<b>BADG-0208-1B *</b>	<b>1</b>	<b>1B234508-1B</b>	N <MMP>
EXPLODED	<b>U004</b>		<b>BADG-0208-1B *</b>	<b>1</b>	<b>1B234508-1B</b>	N <MMO>
EXPLODED	U0040	DAC PC board ass'y	BADG-0208-1A	1	1B2345208-1A	N <MDC>
EXPLODED	U0040	DAC PC board ass'y	BADG-0208-1B	1	1B2345208-1B	N <MMP>
EXPLODED	U0040	DAC PC board ass'y	BADG-0208-1B	1	1B2345208-1B	N <MMO>
EXPLODED	U0041	MAIN CPU PC board ass'y	BACPU-0209-1A	1	1B2345209-1A	N <MDC>
EXPLODED	U0041	MAIN CPU PC board ass'y	BACPU-0209-1B	1	1B2345209-1B	N <MMP>
EXPLODED	U0041	MAIN CPU PC board ass'y	BACPU-0209-1B	1	1B2345209-1B	N <MMO>
EXPLODED	U0042	ZONE-2 & ZONE-3 PC board ass'y	BAAR-0210-1A	1	1B2345210-1A	N <MDC>
EXPLODED	U0042	ZONE-2 & ZONE-3 PC board ass'y	BAAR-0210-1B	1	1B2345210-1B	N <MMP>
EXPLODED	U0042	ZONE-2 & ZONE-3 PC board ass'y	BAAR-0210-1B	1	1B2345210-1B	N <MMO>
EXPLODED	U0043	PHONO AMP. PC board ass'y	BAAF-0211-1A	1	1B2345211-1A	N <MDC>
EXPLODED	U0043	PHONO AMP. PC board ass'y	BAAF-0211-1B	1	1B2345211-1B	N <MMP>
EXPLODED	U0043	PHONO AMP. PC board ass'y	BAAF-0211-1B	1	1B2345211-1B	N <MMO>
EXPLODED	U0044	BUFFER AMP. PC board ass'y	BAACC-0212-1A	1	1B2345212-1A	N <MDC>
EXPLODED	U0044	BUFFER AMP. PC board ass'y	BAACC-0212-1B	1	1B2345212-1B	N <MMP>
EXPLODED	U0044	BUFFER AMP. PC board ass'y	BAACC-0212-1B	1	1B2345212-1B	N <MMO>
EXPLODED	U0045	SIRIUS PC board ass'y	BARF-0204-1A	1	1B2345204-1A	N <MDC>
EXPLODED	U0045	SIRIUS PC board ass'y	BARF-0204-1B	1	1B2345204-1B	N <MMP>
EXPLODED	U0045	SIRIUS PC board ass'y	BARF-0204-1B	1	1B2345204-1B	N <MMO>
EXPLODED	U0046	DG AUDIO IN PC board ass'y	BAETC-0246-1A	1	---	N NSP, <MDC>
EXPLODED	U0046	DG AUDIO IN PC board ass'y	BAETC-0246-1B	1	---	N NSP, <MMP>
EXPLODED	U0046	DG AUDIO IN PC board ass'y	BAETC-0246-1B	1	---	N NSP, <MMO>
EXPLODED	<b>U005</b>	<b>U0050 + U0051 + U0052 + U0053 + U0054</b>	<b>BADIS-0135-1B *</b>	<b>1</b>	<b>1B234535-1B</b>	N <MDC>
EXPLODED	<b>U005</b>	<b>+ U0055 + U0056 + U0057 + U0058</b>	<b>BADIS-0135-1D *</b>	<b>1</b>	<b>1B234535-1D</b>	N <MMP>
EXPLODED	<b>U005</b>	<b>+ U0059 + U00510</b>	<b>BADIS-0135-1D *</b>	<b>1</b>	<b>1B234535-1D</b>	N <MMO>
EXPLODED	U0050	DISPLAY PC board ass'y	BADIS-0135-1B	1	1B2345135-1B	N <MDC>
EXPLODED	U0050	DISPLAY PC board ass'y	BADIS-0135-1D	1	1B2345135-1D	N <MMP>
EXPLODED	U0050	DISPLAY PC board ass'y	BADIS-0135-1D	1	1B2345135-1D	N <MMO>

EXPLODED	U0051	LED PC board ass'y	BASW-0136-1B	1	1B2345136-1B	N <MDC>
EXPLODED	U0051	LED PC board ass'y	BASW-0136-1D	1	1B2345136-1D	N <MMP>
EXPLODED	U0051	LED PC board ass'y	BASW-0136-1D	1	1B2345136-1D	N <MMO>
EXPLODED	U0052	PHONE JACK PC board ass'y	BAETC-0137-1B	1	---	N NSP, <MDC>
EXPLODED	U0052	PHONE JACK PC board ass'y	BAETC-0137-1D	1	---	N NSP, <MMP>
EXPLODED	U0052	PHONE JACK PC board ass'y	BAETC-0137-1D	1	---	N NSP, <MMO>
EXPLODED	U0053	FRONT OPT IN PC board ass'y	BAETC-0138-1B	1	---	N NSP, <MDC>
EXPLODED	U0053	FRONT OPT IN PC board ass'y	BAETC-0138-1D	1	---	N NSP, <MMP>
EXPLODED	U0053	FRONT OPT IN PC board ass'y	BAETC-0138-1D	1	---	N NSP, <MMO>
EXPLODED	U0054	VOLUME PC board ass'y	BAETC-0139-1B	1	---	N NSP, <MDC>
EXPLODED	U0054	VOLUME PC board ass'y	BAETC-0139-1D	1	---	N NSP, <MMP>
EXPLODED	U0054	VOLUME PC board ass'y	BAETC-0139-1D	1	---	N NSP, <MMO>
EXPLODED	U0055	DG POWER SUPPLY PC board ass'y	BAPS-0140-1B	1	1B2345140-1B	N <MDC>
EXPLODED	U0055	DG POWER SUPPLY PC board ass'y	BAPS-0140-1D	1	1B2345140-1D	N <MMP>
EXPLODED	U0055	DG POWER SUPPLY PC board ass'y	BAPS-0140-1D	1	1B2345140-1D	N <MMO>
EXPLODED	U0056	HOLDER PC board	BAETC-0145-1B	1	---	N NSP, <MDC>
EXPLODED	U0056	HOLDER PC board	BAETC-0145-1D	1	---	N NSP, <MMP>
EXPLODED	U0056	HOLDER PC board	BAETC-0145-1D	1	---	N NSP, <MMO>
EXPLODED	U0057	HOLDER PC board	BAETC-0142-1B	1	---	N NSP, <MDC>
EXPLODED	U0057	HOLDER PC board	BAETC-0142-1D	1	---	N NSP, <MMP>
EXPLODED	U0057	HOLDER PC board	BAETC-0142-1D	1	---	N NSP, <MMO>
EXPLODED	U0058	HOLDER PC board	BAETC-0128-1B	1	---	N NSP, <MDC>
EXPLODED	U0058	HOLDER PC board	BAETC-0128-1D	1	---	N NSP, <MMP>
EXPLODED	U0058	HOLDER PC board	BAETC-0128-1D	1	---	N NSP, <MMO>
EXPLODED	U0059	HOLDER PC board	BAETC-0144-1D	1	---	N NSP, <MMP>
EXPLODED	U0059	HOLDER PC board	BAETC-0144-1D	1	---	N NSP, <MMO>
EXPLODED	U00510	POWER SWITCH PC board ass'y	BASW-0143-1D	1	1B2345143-1D	N <MMP>
EXPLODED	U00510	POWER SWITCH PC board ass'y	BASW-0143-1D	1	1B2345143-1D	N <MMO>
EXPLODED	<b>U006</b>	<b>U0060 + U0061 + U0062 + U0063 + U0064</b>	<b>BATRM-0214-1D *</b>	<b>1</b>	<b>1B234514-1D</b>	N <MDC>
EXPLODED	<b>U006</b>	<b>+ U0065</b>	<b>BATRM-0214-1E *</b>	<b>1</b>	<b>1B234514-1E</b>	N <MMP>
EXPLODED	<b>U006</b>		<b>BATRM-0214-1E *</b>	<b>1</b>	<b>1B234514-1E</b>	N <MMO>
EXPLODED	U0060	POWER SUPPLY & SPEAKER TERMINAL PC board ass'y	BATRM-0214-1D	1	1B2345214-1D	N <MDC>
EXPLODED	U0060	POWER SUPPLY & SPEAKER TERMINAL PC board ass'y	BATRM-0214-1E	1	1B2345214-1E	N <MMP>

EXPLODED	U0060	POWER SUPPLY & SPEAKER TERMINAL PC board ass'y	BATRM-0214-1E	1	1B2345214-1E	N <MMO>
EXPLODED	U0061	SPEAKER TERMINAL (RH,SR) PC board ass'y	BATRM-0215-1D	1	1B2345215-1D	N <MDC>
EXPLODED	U0061	SPEAKER TERMINAL (RH,SR) PC board ass'y	BATRM-0215-1E	1	1B2345215-1E	N <MMP>
EXPLODED	U0061	SPEAKER TERMINAL (RH,SR) PC board ass'y	BATRM-0215-1E	1	1B2345215-1E	N <MMO>
EXPLODED	U0062	SPEAKER TERMINAL (CENTER) PC board ass'y	BATRM-0216-1D	1	1B2345216-1D	N <MDC>
EXPLODED	U0062	SPEAKER TERMINAL (CENTER) PC board ass'y	BATRM-0216-1E	1	1B2345216-1E	N <MMP>
EXPLODED	U0062	SPEAKER TERMINAL (CENTER) PC board ass'y	BATRM-0216-1E	1	1B2345216-1E	N <MMO>
EXPLODED	U0063	PRIMARY POWER SUPPLY PC board ass'y	BAPS-0217-1D	1	1B2345217-1D	N <MDC>
EXPLODED	U0063	PRIMARY POWER SUPPLY PC board ass'y	BAPS-0217-1E	1	1B2345217-1E	N <MMP>
EXPLODED	U0063	PRIMARY POWER SUPPLY PC board ass'y	BAPS-0217-1E	1	1B2345217-1E	N <MMO>
EXPLODED	U0064	INLET PC board ass'y	BAPS-0218-1D	1	INCLUDED IN REF.NO. U0063	N <MDC>
EXPLODED	U0064	INLET PC board ass'y	BAPS-0218-1E	1	INCLUDED IN REF.NO. U0063	N <MMP>
EXPLODED	U0064	INLET PC board ass'y	BAPS-0218-1E	1	INCLUDED IN REF.NO. U0063	N <MMO>
EXPLODED	U0065	ANALOG AUDIO POWER SUPPLY PC board ass'y	BAETC-0219-1D	1	---	N NSP, <MDC>
EXPLODED	U0065	ANALOG AUDIO POWER SUPPLY PC board ass'y	BAETC-0219-1E	1	---	N NSP, <MMP>
EXPLODED	U0065	ANALOG AUDIO POWER SUPPLY PC board ass'y	BAETC-0219-1E	1	---	N NSP, <MMO>
EXPLODED	U007	HDMI PC board ass'y	BAHDM-0157-1A *	1	1B234557-1A_0338A2	N
EXPLODED	U008	U0080 + U0080 + U0082 + U0083 + U0084 + U0085 + U0086 + U0087 + U0088	BACLA-0226-1A *	1	1B234526-1A	N
EXPLODED	U0080	AMPLIFIER PC board ass'y (L/SL/SBL/LH)	BACLA-0226-1A	1	1B2345226-1A	N
EXPLODED	U0081	AMPLIFIER PC board ass'y (R/SR/CBR/RH/C)	BACLA-0227-1A	1	1B2345227-1A	N
EXPLODED	U0082	AMPLIFIER PC board ass'y (R/SR/CBR/RH/C)	BACLA-0228-1A	1	1B2345228-1A	N
EXPLODED	U0083	AMPLIFIER PC board ass'y (L/SL/SBL/LH)	BACLA-0229-1A	1	1B2345229-1A	N
EXPLODED	U0084	AMPLIFIER PC board ass'y (R/SR/CBR/RH/C)	BACLA-0230-1A	1	1B2345230-1A	N
EXPLODED	U0085	AMPLIFIER PC board ass'y (L/SL/SBL/LH)	BACLA-0231-1A	1	1B2345231-1A	N
EXPLODED	U0086	AMPLIFIER PC board ass'y (R/SR/CBR/RH/C)	BACLA-0232-1A	1	1B2345232-1A	N
EXPLODED	U0087	AMPLIFIER PC board ass'y (L/SL/SBL/LH)	BACLA-0233-1A	1	1B2345233-1A	N
EXPLODED	U0088	AMPLIFIER PC board ass'y (R/SR/CBR/RH/C)	BACLA-0234-1A	1	1B2345234-1A	N
EXPLODED	U0101	FRONT HDMI/ USB board ass'y	BAHDM-0291-1B	1	1B2345291-1B	N
EXPLODED	U011	TUNER UNIT	FAEH06-E01EX	1	240165	<MMO, MMP>
EXPLODED	U011	TUNER UNIT	FAEH06-A01US	1	240166	<MDC>



## PC BOARD PARTS LIST

PCB-U001	<b>U0010</b>	POWER SUPPLY PC BOARD (BAAF-0180-1A)
PCB-U001	<b>U0011</b>	DIODE PC BOARD (BAPS-0181-1A)
PCB-U001	<b>U0012</b>	RELAY PC BOARD (BAPS-0182-1A)
PCB-U001	<b>U0013</b>	THERMAL SENSOR BOARD (BAETC-0183-1A)
PCB-U001	<b>U0014</b>	THERMAL SENSOR PC BOARD (BAETC-0184-1A)

PCB-U001	CIRCUIT. #	PART NAME	DESCRIPTION	Q'TY	PART NO. (SN)	REMARKS
PCB-U001		[SEMI CONDUCTOR]				
PCB-U001	D6221	DIODE	1SS133	1	223163T	
PCB-U001	D6222	DIODE	1SS133	1	223163T	
PCB-U001	D6601	DIODE	LN25XB60	1	22380345	
PCB-U001	D6602	DIODE	1SS133	1	223163T	
PCB-U001	D6611	DIODE	LN25XB60	1	22380345	
PCB-U001	D6612	DIODE	1SS133	1	223163T	
PCB-U001	D6621	DIODE	LN25XB60	1	22380345	
PCB-U001	D6701	DIODE	1SS133	1	223163T	
PCB-U001	D6702	DIODE	1SS133	1	223163T	
PCB-U001	D6703	ZENER D	MTZJ3.3B	1	224470332T	
PCB-U001	D6704	ZENER D	MTZJ3.3B	1	224470332T	
PCB-U001	D6713	ZENER D	MTZJ3.3B	1	224470332T	
PCB-U001	Q6000	TR	2SC1740S-S	1	2213285T	
PCB-U001	Q6001	TR	2SC1740S-S	1	2213285T	
PCB-U001	Q6002	TR	2SC1740S-S	1	2213285T	
PCB-U001	Q6003	TR	2SC1740S-S	1	2213285T	
PCB-U001	Q6004	TR	2SC1740S-S	1	2213285T	
PCB-U001	Q6005	TR	2SC1740S-S	1	2213285T	
PCB-U001	Q6006	TR	2SC1740S-S	1	2213285T	
PCB-U001	Q6007	TR	2SC1740S-S	1	2213285T	
PCB-U001	Q6008	TR	2SC1740S-S	1	2213285T	
PCB-U001	Q6226	TR	2SB1240-R	1	2213794T	
PCB-U001	Q6380	IC	LM61CIZ	1	22242212	

PCB-U001	Q6380A	RETAINER	(PTH)	1	27141884-1
PCB-U001	Q6381	IC	LM61CIZ	1	22242212
PCB-U001	Q6381A	RETAINER	(PTH)	1	27141884-1
PCB-U001	Q6550	TR	2SC1815-GR	1	2211255T
PCB-U001	Q6551	TR	2SA950-O	1	2211503T
PCB-U001	Q6551 or	TR	2SA950-Y	(1)	2211504T
PCB-U001	Q6560	TR	2SC1815-GR	1	2211255T
PCB-U001	Q6561	TR	2SA950-O	1	2211503T
PCB-U001	Q6561 or	TR	2SA950-Y	(1)	2211504T
PCB-U001	Q6601	TR	KTC3199-GR	1	2215864T
PCB-U001	Q6601 or	TR	2SC1740S-R	(1)	2213284T
PCB-U001	Q6601 or	TR	2SC1740S-S	(1)	2213285T
PCB-U001	Q6611	TR	KTC3199-GR	1	2215864T
PCB-U001	Q6611 or	TR	2SC1740S-R	(1)	2213284T
PCB-U001	Q6611 or	TR	2SC1740S-S	(1)	2213285T
PCB-U001	Q6701	TR	2SC2240-BL(TPE2_F)	1	2211406T
PCB-U001	Q6701 or	TR	KTC3200-BL	(1)	2215896T
PCB-U001	Q6702	TR	2SC2240-BL(TPE2_F)	1	2211406T
PCB-U001	Q6702 or	TR	KTC3200-BL	(1)	2215896T
PCB-U001	Q6703	TR	2SA970-BL(TPE2_F)	1	2211396T
PCB-U001	Q6703 or	TR	KTA1268-BL	(1)	2215886T
PCB-U001	Q6713	TR	2SA970-BL(TPE2_F)	1	2211396T
PCB-U001	Q6713 or	TR	KTA1268-BL	(1)	2215886T
PCB-U001	<b>[CAPACITOR]</b>				
PCB-U001	C6222	UTSP C	CE04W25V-220M(UTSP)	1	397552217T
PCB-U001	C6601	MKT C	B32529C0102J289	1	376491024T
PCB-U001	C6601 or	TF C	ECQ-B50V-102J	(1)	374721024T
PCB-U001	C6602	PLA C	ECQE250V-334J	1	3700083S
PCB-U001	C6611	MKT C	B32529C0102J289	1	376491024T
PCB-U001	C6611 or	TF C	ECQ-B50V-102J	(1)	374721024T
PCB-U001	C6612	TF C	ECQ-V100V-334J	1	374733344T
PCB-U001	C6622	TF C	ECQ-V100V-334J	1	374733344T
PCB-U001	C6701	UTSP C	CE04W16V-330M(UTSP)	1	397543317T

PCB-U001	C6703	TF C	ECQ-V50V-223J	1	374722234T
PCB-U001	C6704	UTSP C	CE04W50V-1M(UTSP)	1	397580107T
PCB-U001	C6706	UTSP C	CE04W50V-10M(UTSP)	1	397581007T
PCB-U001	C6713	TF C	ECQ-V50V-223J	1	374722234T
PCB-U001	C6714	UTSP C	CE04W50V-1M(UTSP)	1	397580107T
PCB-U001	C6901	ELECT C	CE69W75V-18000M	1	3504437A
PCB-U001	C6902	ELECT C	CE69W75V-18000M	1	3504437A
PCB-U001	<b>[RESISTOR]</b>				
PCB-U001	R6222	METAL R	RNU1WCJ-1	1	453630104T
PCB-U001	R6223	CARBON R	R16J-5.6K	1	417345624T
PCB-U001	R6550	CARBON R	R16J-4.7K	1	417344724T
PCB-U001	R6551	CARBON R	R16J-330	1	417343314T
PCB-U001	R6552	CARBON R	R16J-1.8K	1	417341824T
PCB-U001	R6553	CARBON R	R16J-1.2K	1	417341224T
PCB-U001	R6554	CARBON R	R16J-22K	1	417342234T
PCB-U001	R6560	CARBON R	R16J-4.7K	1	417344724T
PCB-U001	R6561	CARBON R	R16J-330	1	417343314T
PCB-U001	R6562	CARBON R	R16J-1.8K	1	417341824T
PCB-U001	R6563	CARBON R	R16J-1.2K	1	417341224T
PCB-U001	R6564	CARBON R	R16J-22K	1	417342234T
PCB-U001	R6601	CARBON R	R16J-1K	1	417341024T
PCB-U001	R6602	CARBON R	R16J-4.7K	1	417344724T
PCB-U001	R6603	METAL O R	RS1/2WBJ-22	1	443522204T
PCB-U001	R6611	CARBON R	R16J-1K	1	417341024T
PCB-U001	R6612	CARBON R	R16J-4.7K	1	417344724T
PCB-U001	R6613	METAL O R	RS1/2WBJ-22	1	443522204T
PCB-U001	R6701	CARBON R	R16J-22K	1	417342234T
PCB-U001	R6702	CARBON R	R16J-10K	1	417341034T
PCB-U001	R6704	CARBON R	R16J-33K	1	417343334T
PCB-U001	R6706	CARBON R	R16J-22K	1	417342234T
PCB-U001	R6708	CARBON R	R16J-33K	1	417343334T
PCB-U001	R6709	CARBON R	R16J-5.6K	1	417345624T
PCB-U001	R6710	CARBON R	R16J-15K	1	417341534T

PCB-U001	R6712	CARBON R	R16J-10K	1	417341034T	
PCB-U001	R6714	CARBON R	R16J-33K	1	417343334T	
PCB-U001	R6716	CARBON R	R16J-22K	1	417342234T	
PCB-U001	[SW TRM]					
PCB-U001	F6601A	FUSE HOLDER	SN5051	1	250113	!
PCB-U001	F6601B	FUSE HOLDER	SN5051	1	250113	!
PCB-U001	F6602A	FUSE HOLDER	SN5051	1	250113	!
PCB-U001	F6602B	FUSE HOLDER	SN5051	1	250113	!
PCB-U001	F6603A	FUSE HOLDER	SN5051	1	250113	!
PCB-U001	F6603B	FUSE HOLDER	SN5051	1	250113	!
PCB-U001	F6604A	FUSE HOLDER	SN5051	1	250113	!
PCB-U001	F6604B	FUSE HOLDER	SN5051	1	250113	!
PCB-U001	JL6041A	WIRE HOL	NSCT-3P874	1	25051087	
PCB-U001	JL6402A	WIRE TRAP	NPLG-3P586	1	25055624	
PCB-U001	JL6402B	WIRE HOL	NSCT-3P874	1	25051087	
PCB-U001	JL6403A	WIRE TRAP	NPLG-3P586	1	25055624	
PCB-U001	JL6403B	WIRE HOL	NSCT-3P874	1	25051087	
PCB-U001	JL6602A	WIRE HOL	NSCT-5P876	1	25051089	
PCB-U001	JL6602B	WIRE TRAP	NPLG-5P588	1	25055626	
PCB-U001	JL6900A	WIRE HOL	NSCT-3P894	1	25051107	
PCB-U001	P001	PWB	BCAF-0180	1	25140180B	N
PCB-U001	P002	PWB	BCPS-0181	{ 1 }	25140181	N
PCB-U001	P003	PWB	BCPS-0182	{ 1 }	25140182	N
PCB-U001	P004	PWB	BCETC-0183	{ 1 }	25140183	N
PCB-U001	P005	PWB	BCETC-0184	{ 1 }	25140184	N
PCB-U001	P5000A	SOCKET AS	NSAS-20P1811	1	2009991171UL	
PCB-U001	P5001A	SOCKET AS	NSAS-16P1810	1	2009991170UL	
PCB-U001	P5002A	CRIMP AS	CRIMP SR805_1	1	20799169UL	
PCB-U001	P5010B	PLUG	NPLG-3P0958	1	25056008	
PCB-U001	P5011B	PLUG	NPLG-3P0958	1	25056008	
PCB-U001	P5012B	PLUG	NPLG-3P0958	1	25056008	
PCB-U001	P5013B	PLUG	NPLG-3P0958	1	25056008	
PCB-U001	P5014B	PLUG	NPLG-3P0958	1	25056008	

PCB-U001	P5015B	PLUG	NPLG-3P0958	1	25056008	
PCB-U001	P5016B	PLUG	NPLG-3P0958	1	25056008	
PCB-U001	P5017B	PLUG	NPLG-3P0958	1	25056008	
PCB-U001	P5018B	PLUG	NPLG-3P0958	1	25056008	
PCB-U001	P5020B	TRM	NTM-1P232(M1700)	1	25060301	
PCB-U001	P5021B	TRM	NTM-1P232(M1700)	1	25060301	
PCB-U001	P5022B	TRM	NTM-1P232(M1700)	1	25060301	
PCB-U001	P5023B	TRM	NTM-1P232(M1700)	1	25060301	
PCB-U001	P5024B	TRM	NTM-1P232(M1700)	1	25060301	
PCB-U001	P5025B	TRM	NTM-1P232(M1700)	1	25060301	
PCB-U001	P5026B	TRM	NTM-1P232(M1700)	1	25060301	
PCB-U001	P5027B	TRM	NTM-1P232(M1700)	1	25060301	
PCB-U001	P5028B	TRM	NTM-1P232(M1700)	1	25060301	
PCB-U001	P6010B	PLUG	NPLG-3P0958	1	25056008	
PCB-U001	P6011B	PLUG	NPLG-3P0958	1	25056008	
PCB-U001	P6012B	PLUG	NPLG-3P0958	1	25056008	
PCB-U001	P6013B	PLUG	NPLG-3P0958	1	25056008	
PCB-U001	P6014B	PLUG	NPLG-3P0958	1	25056008	
PCB-U001	P6015B	PLUG	NPLG-3P0958	1	25056008	
PCB-U001	P6016B	PLUG	NPLG-3P0958	1	25056008	
PCB-U001	P6017B	PLUG	NPLG-3P0958	1	25056008	
PCB-U001	P6018B	PLUG	NPLG-3P0958	1	25056008	
PCB-U001	P6140	SOCKET AS	NSAS-9P1790	1	2009991156UL	
PCB-U001	P6240	SOCKET AS	NSAS-9P1812	1	2009991172AUL	N
PCB-U001	P6340	SOCKET AS	NSAS-8P1660	1	2009991064AUL	
PCB-U001	P6500	PLUG	NPLG-7P163	1	25055179	
PCB-U001	P6550	PLUG	NPLG-2P83	1	25055099	
PCB-U001	P6560	PLUG	NPLG-2P568	1	25055600	
PCB-U001	P6601	SOCKET AS	NSAS7P-1815	1	2009991174UL	N
PCB-U001	P6601A	PLUG	NPLG-7P163	1	25055179	
PCB-U001	P6602	RETAINER	(TRM-12)	1	27142148	N
PCB-U001	P6602B	RETAINER	MET37-0002	1	27142009T	
PCB-U001	P6603	RETAINER	(TRM-12)	1	27142148	N

PCB-U001	P6603B	RETAINER	MET37-0002	1	27142009T	
PCB-U001	P7210A	SOCKET AS	NSAS-22P1792	1	2009991158UL	N
PCB-U001	RL6601	RELAY	G2RL-1A-E-DC12V-423	1	25060496	N
PCB-U001	RL6602	RELAY	G2RL-1A-E-DC12V-423	1	25060496	N
PCB-U001	RL6611	RELAY	G2RL-1A-E-DC12V-423	1	25060496	N
PCB-U001	RL6612	RELAY	G2RL-1A-E-DC12V-423	1	25060496	N
PCB-U001	<b>[TUNER UNIT]</b>					
PCB-U001	P6202	HOLDER	HOLDER(CLAMP)	1	27190540-1	
PCB-U001	P6400	RETAINER	(BUS-3)	1	27142058A	
PCB-U001	P6401	RETAINER	(BUS-S)	1	27142147	N
PCB-U001	P6402	RETAINER	(BUS-L)	1	27142146	N
PCB-U002	<b>U0020</b>	AMPLIFIER PC BOARD (C,SR,RH,SBR,R) (BAAMP-0191-1A)				
PCB-U002	<b>U0021</b>	AMPLIFIER PC BOARD (L,SBL,LH,SL) (BAAMP-0192-1A)				
PCB-U002						
PCB-U002	<b>CIRCUIT. #</b>	<b>PART NAME</b>	<b>DESCRIPTION</b>	<b>Q'TY</b>	<b>PART NO. (SN)</b>	<b>REMARKS</b>
PCB-U002	<b>[SEMI CONDUCTOR]</b>					
PCB-U002	D6000	DIODE	1SS133	1	223163T	
PCB-U002	D6001	DIODE	1SS133	1	223163T	
PCB-U002	D6002	DIODE	1SS133	1	223163T	
PCB-U002	D6003	DIODE	1SS133	1	223163T	
PCB-U002	D6004	DIODE	1SS133	1	223163T	
PCB-U002	D6005	DIODE	1SS133	1	223163T	
PCB-U002	D6006	DIODE	1SS133	1	223163T	
PCB-U002	D6007	DIODE	1SS133	1	223163T	
PCB-U002	D6008	DIODE	1SS133	1	223163T	
PCB-U002	Q6070	TR	2SC2631-R	1	2214984T	
PCB-U002	Q6070 or	TR	2SC2631-S	( 1)	2214985T	
PCB-U002	Q6071	TR	2SC2631-R	1	2214984T	
PCB-U002	Q6071 or	TR	2SC2631-S	( 1)	2214985T	
PCB-U002	Q6072	TR	2SC2631-R	1	2214984T	
PCB-U002	Q6072 or	TR	2SC2631-S	( 1)	2214985T	
PCB-U002	Q6073	TR	2SC2631-R	1	2214984T	

PCB-U002	Q6073 or	TR	2SC2631-S	( 1)	2214985T	
PCB-U002	Q6074	TR	2SC2631-R	1	2214984T	
PCB-U002	Q6074 or	TR	2SC2631-S	( 1)	2214985T	
PCB-U002	Q6075	TR	2SC2631-R	1	2214984T	
PCB-U002	Q6075 or	TR	2SC2631-S	( 1)	2214985T	
PCB-U002	Q6076	TR	2SC2631-R	1	2214984T	
PCB-U002	Q6076 or	TR	2SC2631-S	( 1)	2214985T	
PCB-U002	Q6077	TR	2SC2631-R	1	2214984T	
PCB-U002	Q6077 or	TR	2SC2631-S	( 1)	2214985T	
PCB-U002	Q6078	TR	2SC2631-R	1	2214984T	
PCB-U002	Q6078 or	TR	2SC2631-S	( 1)	2214985T	
PCB-U002	<b>[TRANS COIL]</b>					
PCB-U002	L6000	FR CORE	*	1	5597-45502	
PCB-U002	L6001	FR CORE	*	1	5597-45502	
PCB-U002	L6002	FR CORE	*	1	5597-45502	
PCB-U002	L6003	FR CORE	*	1	5597-45502	
PCB-U002	L6004	FR CORE	*	1	5597-45502	
PCB-U002	L6005	FR CORE	*	1	5597-45502	
PCB-U002	L6006	FR CORE	*	1	5597-45502	
PCB-U002	L6007	FR CORE	*	1	5597-45502	
PCB-U002	L6008	FR CORE	*	1	5597-45502	
PCB-U002	L6010	FR CORE	*	1	5597-45502	
PCB-U002	L6011	FR CORE	*	1	5597-45502	
PCB-U002	L6012	FR CORE	*	1	5597-45502	
PCB-U002	L6013	FR CORE	*	1	5597-45502	
PCB-U002	L6014	FR CORE	*	1	5597-45502	
PCB-U002	L6015	FR CORE	*	1	5597-45502	
PCB-U002	L6016	FR CORE	*	1	5597-45502	
PCB-U002	L6017	FR CORE	*	1	5597-45502	
PCB-U002	L6018	FR CORE	*	1	5597-45502	
PCB-U002	<b>[CAPACITOR]</b>					
PCB-U002	C6040	TF C	ECQ-V50V-223J	1	374722234T	
PCB-U002	C6041	TF C	ECQ-V50V-223J	1	374722234T	

PCB-U002	C6042	TF C	ECQ-V50V-223J	1	374722234T
PCB-U002	C6043	TF C	ECQ-V50V-223J	1	374722234T
PCB-U002	C6044	TF C	ECQ-V50V-223J	1	374722234T
PCB-U002	C6045	TF C	ECQ-V50V-223J	1	374722234T
PCB-U002	C6046	TF C	ECQ-V50V-223J	1	374722234T
PCB-U002	C6047	TF C	ECQ-V50V-223J	1	374722234T
PCB-U002	C6048	TF C	ECQ-V50V-223J	1	374722234T
PCB-U002	<b>[RESISTOR]</b>				
PCB-U002	R6080	METAL O R	RS1/2WBJ-10	1	443521004T
PCB-U002	R6081	METAL O R	RS1/2WBJ-10	1	443521004T
PCB-U002	R6082	METAL O R	RS1/2WBJ-10	1	443521004T
PCB-U002	R6083	METAL O R	RS1/2WBJ-10	1	443521004T
PCB-U002	R6084	METAL O R	RS1/2WBJ-10	1	443521004T
PCB-U002	R6085	METAL O R	RS1/2WBJ-10	1	443521004T
PCB-U002	R6086	METAL O R	RS1/2WBJ-10	1	443521004T
PCB-U002	R6087	METAL O R	RS1/2WBJ-10	1	443521004T
PCB-U002	R6088	METAL O R	RS1/2WBJ-10	1	443521004T
PCB-U002	R6090	METAL O R	RS1/2WBJ-10	1	443521004T
PCB-U002	R6091	METAL O R	RS1/2WBJ-10	1	443521004T
PCB-U002	R6092	METAL O R	RS1/2WBJ-10	1	443521004T
PCB-U002	R6093	METAL O R	RS1/2WBJ-10	1	443521004T
PCB-U002	R6094	METAL O R	RS1/2WBJ-10	1	443521004T
PCB-U002	R6095	METAL O R	RS1/2WBJ-10	1	443521004T
PCB-U002	R6096	METAL O R	RS1/2WBJ-10	1	443521004T
PCB-U002	R6097	METAL O R	RS1/2WBJ-10	1	443521004T
PCB-U002	R6098	METAL O R	RS1/2WBJ-10	1	443521004T
PCB-U002	R6170	CARBON R	R16J-33K	1	417343334T
PCB-U002	R6171	CARBON R	R16J-33K	1	417343334T
PCB-U002	R6172	CARBON R	R16J-33K	1	417343334T
PCB-U002	R6173	CARBON R	R16J-33K	1	417343334T
PCB-U002	R6174	CARBON R	R16J-33K	1	417343334T
PCB-U002	R6175	CARBON R	R16J-33K	1	417343334T
PCB-U002	R6176	CARBON R	R16J-33K	1	417343334T



PCB-U002	R6177	CARBON R	R16J-33K	1	417343334T
PCB-U002	R6178	CARBON R	R16J-33K	1	417343334T
PCB-U002	R6180	CARBON R	R16J-56K	1	417345634T
PCB-U002	R6181	CARBON R	R16J-56K	1	417345634T
PCB-U002	R6182	CARBON R	R16J-56K	1	417345634T
PCB-U002	R6183	CARBON R	R16J-56K	1	417345634T
PCB-U002	R6184	CARBON R	R16J-56K	1	417345634T
PCB-U002	R6185	CARBON R	R16J-56K	1	417345634T
PCB-U002	R6186	CARBON R	R16J-56K	1	417345634T
PCB-U002	R6187	CARBON R	R16J-56K	1	417345634T
PCB-U002	R6188	CARBON R	R16J-56K	1	417345634T
PCB-U002	R6190	CARBON R	R16J-10K	1	417341034T
PCB-U002	R6191	CARBON R	R16J-10K	1	417341034T
PCB-U002	R6192	CARBON R	R16J-10K	1	417341034T
PCB-U002	R6193	CARBON R	R16J-10K	1	417341034T
PCB-U002	R6194	CARBON R	R16J-10K	1	417341034T
PCB-U002	R6195	CARBON R	R16J-10K	1	417341034T
PCB-U002	R6196	CARBON R	R16J-10K	1	417341034T
PCB-U002	R6197	CARBON R	R16J-10K	1	417341034T
PCB-U002	R6198	CARBON R	R16J-10K	1	417341034T
PCB-U002	R6210	CARBON R	R16J-47K	1	417344734T
PCB-U002	R6211	CARBON R	R16J-47K	1	417344734T
PCB-U002	R6212	CARBON R	R16J-47K	1	417344734T
PCB-U002	R6213	CARBON R	R16J-47K	1	417344734T
PCB-U002	R6214	CARBON R	R16J-47K	1	417344734T
PCB-U002	R6215	CARBON R	R16J-47K	1	417344734T
PCB-U002	R6216	CARBON R	R16J-47K	1	417344734T
PCB-U002	R6217	CARBON R	R16J-47K	1	417344734T
PCB-U002	R6218	CARBON R	R16J-47K	1	417344734T
PCB-U002	R6230	CARBON R	R16J-47K	1	417344734T
PCB-U002	R6231	CARBON R	R16J-47K	1	417344734T
PCB-U002	R6232	CARBON R	R16J-47K	1	417344734T
PCB-U002	R6233	CARBON R	R16J-47K	1	417344734T

PCB-U002	R6234	CARBON R	R16J-47K	1	417344734T	
PCB-U002	R6235	CARBON R	R16J-47K	1	417344734T	
PCB-U002	R6236	CARBON R	R16J-47K	1	417344734T	
PCB-U002	R6237	CARBON R	R16J-47K	1	417344734T	
PCB-U002	R6238	CARBON R	R16J-47K	1	417344734T	
PCB-U002	R6400	METAL PR	MPR2W+2WK 0R47	1	4000253	N
PCB-U002	R6401	METAL PR	MPR2W+2WK 0R47	1	4000253	N
PCB-U002	R6402	METAL PR	MPR2W+2WK 0R47	1	4000253	N
PCB-U002	R6403	METAL PR	MPR2W+2WK 0R47	1	4000253	N
PCB-U002	R6404	METAL PR	MPR2W+2WK 0R47	1	4000253	N
PCB-U002	R6405	METAL PR	MPR2W+2WK 0R47	1	4000253	N
PCB-U002	R6406	METAL PR	MPR2W+2WK 0R47	1	4000253	N
PCB-U002	R6407	METAL PR	MPR2W+2WK 0R47	1	4000253	N
PCB-U002	R6408	METAL PR	MPR2W+2WK 0R47	1	4000253	N
PCB-U002	R6410	METAL PR	MPR2W+2WK 0R47	1	4000253	N
PCB-U002	R6411	METAL PR	MPR2W+2WK 0R47	1	4000253	N
PCB-U002	R6412	METAL PR	MPR2W+2WK 0R47	1	4000253	N
PCB-U002	R6413	METAL PR	MPR2W+2WK 0R47	1	4000253	N
PCB-U002	R6414	METAL PR	MPR2W+2WK 0R47	1	4000253	N
PCB-U002	R6415	METAL PR	MPR2W+2WK 0R47	1	4000253	N
PCB-U002	R6416	METAL PR	MPR2W+2WK 0R47	1	4000253	N
PCB-U002	R6417	METAL PR	MPR2W+2WK 0R47	1	4000253	N
PCB-U002	R6418	METAL PR	MPR2W+2WK 0R47	1	4000253	N
PCB-U002	<a href="#">[SW TRM]</a>					
PCB-U002	JL6041B	WIRE TRAP	NPLG-3P586	1	25055624	
PCB-U002	JL6042A	WIRE HOL	NSCT-3P874	1	25051087	
PCB-U002	JL6042B	WIRE TRAP	NPLG-3P586	1	25055624	
PCB-U002	P001	PWB	BCAMP-0191	1	25140191B	N
PCB-U002	P002	PWB	BCAMP-0192	{ 1 }	25140192	N
PCB-U002	P6030A	PLUG	IMSA-9115B-05	1	25056335	N
PCB-U002	P6031A	PLUG	IMSA-9115B-05	1	25056335	N
PCB-U002	P6032A	PLUG	IMSA-9115B-05	1	25056335	N
PCB-U002	P6033A	PLUG	IMSA-9115B-05	1	25056335	N

PCB-U002	P6034A	PLUG	IMSA-9115B-05	1	25056335	N
PCB-U002	P6035A	PLUG	IMSA-9115B-05	1	25056335	N
PCB-U002	P6036A	PLUG	IMSA-9115B-05	1	25056335	N
PCB-U002	P6037A	PLUG	IMSA-9115B-05	1	25056335	N
PCB-U002	P6038A	PLUG	IMSA-9115B-05	1	25056335	N
PCB-U002	P6050	PLUG	IMSA-9201B-1-06Z388-PT1	1	25056614	
PCB-U002	P6051	PLUG	IMSA-9201B-1-06Z388-PT1	1	25056614	
PCB-U002	P6052	PLUG	IMSA-9201B-1-06Z388-PT1	1	25056614	
PCB-U002	P6053	PLUG	IMSA-9201B-1-06Z388-PT1	1	25056614	
PCB-U002	P6054	PLUG	IMSA-9201B-1-06Z388-PT1	1	25056614	
PCB-U002	P6055	PLUG	IMSA-9201B-1-06Z388-PT1	1	25056614	
PCB-U002	P6056	PLUG	IMSA-9201B-1-06Z388-PT1	1	25056614	
PCB-U002	P6057	PLUG	IMSA-9201B-1-06Z388-PT1	1	25056614	
PCB-U002	P6058	PLUG	IMSA-9201B-1-06Z388-PT1	1	25056614	
PCB-U002	P6060	PLUG	IMSA-9201B-1-06Z388-PT1	1	25056614	
PCB-U002	P6061	PLUG	IMSA-9201B-1-06Z388-PT1	1	25056614	
PCB-U002	P6062	PLUG	IMSA-9201B-1-06Z388-PT1	1	25056614	
PCB-U002	P6063	PLUG	IMSA-9201B-1-06Z388-PT1	1	25056614	
PCB-U002	P6064	PLUG	IMSA-9201B-1-06Z388-PT1	1	25056614	
PCB-U002	P6065	PLUG	IMSA-9201B-1-06Z388-PT1	1	25056614	
PCB-U002	P6066	PLUG	IMSA-9201B-1-06Z388-PT1	1	25056614	
PCB-U002	P6067	PLUG	IMSA-9201B-1-06Z388-PT1	1	25056614	
PCB-U002	P6068	PLUG	IMSA-9201B-1-06Z388-PT1	1	25056614	
PCB-U002	P6070	PLUG	NPLG-2P645	1	25055689	
PCB-U002	P6071	PLUG	NPLG-2P645	1	25055689	
PCB-U002	P6072	PLUG	NPLG-2P645	1	25055689	
PCB-U002	P6073	PLUG	NPLG-2P645	1	25055689	
PCB-U002	P6074	PLUG	NPLG-2P645	1	25055689	
PCB-U002	P6075	PLUG	NPLG-2P645	1	25055689	
PCB-U002	P6076	PLUG	NPLG-2P645	1	25055689	
PCB-U002	P6077	PLUG	NPLG-2P645	1	25055689	
PCB-U002	P6078	PLUG	NPLG-2P645	1	25055689	
PCB-U002	P6240	SOCKET AS	NSAS-4P1789	1	2009991155AUL	N

PCB-U002	P6250	SOCKET AS	NSAS-5P1791	1	2009991157AUL	N
PCB-U002	P6340A	PLUG	NPLG-2P149	1	25055165	
PCB-U002	P6350A	PLUG	NPLG-2P149	1	25055165	
PCB-U002	[TUNER UNIT]					
PCB-U002	P6340B	RETAINER	(AMP-4)	1	27142144	N
PCB-U002	P6340C	RETAINER	(AMP-4)	1	27142144	N
PCB-U002	P6350B	RETAINER	(AMP-5)	1	27142145	N
PCB-U002	P6350C	RETAINER	(AMP-5)	1	27142145	N
PCB-U003	<b>U0030</b>	ANALOG AUDIO PC BOARD (BAASP-0202-1D)				
PCB-U003	<b>U0031</b>	ANALOG VIDEO PC BOARD (BAVD-0203-1D)				
PCB-U003						
PCB-U003	<b>CIRCUIT. #</b>	<b>PART NAME</b>	<b>DESCRIPTION</b>	<b>Q'TY</b>	<b>PART NO. (SN)</b>	<b>REMARKS</b>
PCB-U003	[TUNER UNIT]					
PCB-U003	U2700	REMO SENS	KSM-603TE2Q	1	24130018	N
PCB-U003	[SEMI CONDUCTOR]					
PCB-U003	D2000	DIODE	D5SBA20	1	22380130	
PCB-U003	D2000A	HEAT SINK	RAD-083	1	27160271	
PCB-U003	D2000B	SCREW	3P+6FN(3BC)	1	82143006GR	
PCB-U003	D2001	C-DIODE	1SS352	1	223234R2	
PCB-U003	D2001 or	C-DIODE	1SS355	(1)	223269R2	
PCB-U003	D2001 or	C-DIODE	MA2J111	(1)	223279R2	
PCB-U003	D2001 or	C-DIODE	KDS4148U	(1)	223283R2	
PCB-U003	D2003	DIODE	RB070M-30	1	22380361R2	
PCB-U003	D2004	ZENER D	UDZS3.9B	1	224550390R2	
PCB-U003	D2005	DIODE	RL1N4003	1	22380260T	
PCB-U003	D2006	DIODE	RL1N4003	1	22380260T	
PCB-U003	D2007	DIODE	RL1N4003	1	22380260T	
PCB-U003	D2008	DIODE	RL1N4003	1	22380260T	
PCB-U003	D2009	ZENER D	UDZS3.9B	1	224550390R2	
PCB-U003	D2010	C-DIODE	1SS352	1	223234R2	
PCB-U003	D2010 or	C-DIODE	1SS355	(1)	223269R2	
PCB-U003	D2010 or	C-DIODE	MA2J111	(1)	223279R2	

PCB-U003	D2010 or	C-DIODE	KDS4148U	(1)	223283R2
PCB-U003	D2011	C-DIODE	1SS352	1	223234R2
PCB-U003	D2011 or	C-DIODE	1SS355	(1)	223269R2
PCB-U003	D2011 or	C-DIODE	MA2J111	(1)	223279R2
PCB-U003	D2011 or	C-DIODE	KDS4148U	(1)	223283R2
PCB-U003	D2012	DIODE	RL1N4003	1	22380260T
PCB-U003	D2013	DIODE	RL1N4003	1	22380260T
PCB-U003	D2014	ZENER D	UDZS5.1B	1	224550510R2
PCB-U003	D2015	C-DIODE	1SS352	1	223234R2
PCB-U003	D2015 or	C-DIODE	1SS355	(1)	223269R2
PCB-U003	D2015 or	C-DIODE	MA2J111	(1)	223279R2
PCB-U003	D2015 or	C-DIODE	KDS4148U	(1)	223283R2
PCB-U003	D2700	SPCF D	SIR-34ST3F	1	225456
PCB-U003	D2702	C-DIODE	1SS352	1	223234R2
PCB-U003	D2702 or	C-DIODE	1SS355	(1)	223269R2
PCB-U003	D2702 or	C-DIODE	MA2J111	(1)	223279R2
PCB-U003	D2702 or	C-DIODE	KDS4148U	(1)	223283R2
PCB-U003	D2703	C-DIODE	1SS352	1	223234R2
PCB-U003	D2703 or	C-DIODE	1SS355	(1)	223269R2
PCB-U003	D2703 or	C-DIODE	MA2J111	(1)	223279R2
PCB-U003	D2703 or	C-DIODE	KDS4148U	(1)	223283R2
PCB-U003	D2704	C-DIODE	1SS352	1	223234R2
PCB-U003	D2704 or	C-DIODE	1SS355	(1)	223269R2
PCB-U003	D2704 or	C-DIODE	MA2J111	(1)	223279R2
PCB-U003	D2704 or	C-DIODE	KDS4148U	(1)	223283R2
PCB-U003	D2705	C-DIODE	1SS352	1	223234R2
PCB-U003	D2705 or	C-DIODE	1SS355	(1)	223269R2
PCB-U003	D2705 or	C-DIODE	MA2J111	(1)	223279R2
PCB-U003	D2705 or	C-DIODE	KDS4148U	(1)	223283R2
PCB-U003	D2708	DIODE	RL1N4003	1	22380260T
PCB-U003	D4005	ZENER D	UDZS7.5B	1	224550750R2
PCB-U003	D4006	ZENER D	UDZS7.5B	1	224550750R2
PCB-U003	D4007	C-DIODE	1SS352	1	223234R2

PCB-U003	D4007 or	C-DIODE	1SS355	(1)	223269R2
PCB-U003	D4007 or	C-DIODE	MA2J111	(1)	223279R2
PCB-U003	D4007 or	C-DIODE	KDS4148U	(1)	223283R2
PCB-U003	D4008	C-DIODE	1SS352	1	223234R2
PCB-U003	D4008 or	C-DIODE	1SS355	(1)	223269R2
PCB-U003	D4008 or	C-DIODE	MA2J111	(1)	223279R2
PCB-U003	D4008 or	C-DIODE	KDS4148U	(1)	223283R2
PCB-U003	D4019	C-DIODE	1SS352	1	223234R2
PCB-U003	D4019 or	C-DIODE	1SS355	(1)	223269R2
PCB-U003	D4019 or	C-DIODE	MA2J111	(1)	223279R2
PCB-U003	D4019 or	C-DIODE	KDS4148U	(1)	223283R2
PCB-U003	D4401	ZENER D	UDZS9.1B	1	224550910R2
PCB-U003	D4402	ZENER D	UDZS9.1B	1	224550910R2
PCB-U003	D4403	ZENER D	UDZS3.3B	1	224550330R2
PCB-U003	D4404	C-DIODE	1SS352	1	223234R2
PCB-U003	D4404 or	C-DIODE	1SS355	(1)	223269R2
PCB-U003	D4404 or	C-DIODE	MA2J111	(1)	223279R2
PCB-U003	D4404 or	C-DIODE	KDS4148U	(1)	223283R2
PCB-U003	D4405	C-DIODE	1SS352	1	223234R2
PCB-U003	D4405 or	C-DIODE	1SS355	(1)	223269R2
PCB-U003	D4405 or	C-DIODE	MA2J111	(1)	223279R2
PCB-U003	D4405 or	C-DIODE	KDS4148U	(1)	223283R2
PCB-U003	D4431	C-DIODE	1SS352	1	223234R2
PCB-U003	D4431 or	C-DIODE	1SS355	(1)	223269R2
PCB-U003	D4431 or	C-DIODE	MA2J111	(1)	223279R2
PCB-U003	D4431 or	C-DIODE	KDS4148U	(1)	223283R2
PCB-U003	D4432	C-DIODE	1SS352	1	223234R2
PCB-U003	D4432 or	C-DIODE	1SS355	(1)	223269R2
PCB-U003	D4432 or	C-DIODE	MA2J111	(1)	223279R2
PCB-U003	D4432 or	C-DIODE	KDS4148U	(1)	223283R2
PCB-U003	D4433	C-DIODE	1SS352	1	223234R2
PCB-U003	D4433 or	C-DIODE	1SS355	(1)	223269R2
PCB-U003	D4433 or	C-DIODE	MA2J111	(1)	223279R2

PCB-U003	D4433 or	C-DIODE	KDS4148U	(1)	223283R2
PCB-U003	D4434	C-DIODE	1SS352	1	223234R2
PCB-U003	D4434 or	C-DIODE	1SS355	(1)	223269R2
PCB-U003	D4434 or	C-DIODE	MA2J111	(1)	223279R2
PCB-U003	D4434 or	C-DIODE	KDS4148U	(1)	223283R2
PCB-U003	D4435	C-DIODE	1SS352	1	223234R2
PCB-U003	D4435 or	C-DIODE	1SS355	(1)	223269R2
PCB-U003	D4435 or	C-DIODE	MA2J111	(1)	223279R2
PCB-U003	D4435 or	C-DIODE	KDS4148U	(1)	223283R2
PCB-U003	D4436	C-DIODE	1SS352	1	223234R2
PCB-U003	D4436 or	C-DIODE	1SS355	(1)	223269R2
PCB-U003	D4436 or	C-DIODE	MA2J111	(1)	223279R2
PCB-U003	D4436 or	C-DIODE	KDS4148U	(1)	223283R2
PCB-U003	D4441	C-DIODE	1SS352	1	223234R2
PCB-U003	D4441 or	C-DIODE	1SS355	(1)	223269R2
PCB-U003	D4441 or	C-DIODE	MA2J111	(1)	223279R2
PCB-U003	D4441 or	C-DIODE	KDS4148U	(1)	223283R2
PCB-U003	D4442	C-DIODE	1SS352	1	223234R2
PCB-U003	D4442 or	C-DIODE	1SS355	(1)	223269R2
PCB-U003	D4442 or	C-DIODE	MA2J111	(1)	223279R2
PCB-U003	D4442 or	C-DIODE	KDS4148U	(1)	223283R2
PCB-U003	D4443	C-DIODE	1SS352	1	223234R2
PCB-U003	D4443 or	C-DIODE	1SS355	(1)	223269R2
PCB-U003	D4443 or	C-DIODE	MA2J111	(1)	223279R2
PCB-U003	D4443 or	C-DIODE	KDS4148U	(1)	223283R2
PCB-U003	D4444	C-DIODE	1SS352	1	223234R2
PCB-U003	D4444 or	C-DIODE	1SS355	(1)	223269R2
PCB-U003	D4444 or	C-DIODE	MA2J111	(1)	223279R2
PCB-U003	D4444 or	C-DIODE	KDS4148U	(1)	223283R2
PCB-U003	D4445	C-DIODE	1SS352	1	223234R2
PCB-U003	D4445 or	C-DIODE	1SS355	(1)	223269R2
PCB-U003	D4445 or	C-DIODE	MA2J111	(1)	223279R2
PCB-U003	D4445 or	C-DIODE	KDS4148U	(1)	223283R2

PCB-U003	Q2000	IC	78M05(NJM78M05FA)	1	222780055JRC	
PCB-U003	Q2001	TR	2SC3851-Y	1	2203384	
PCB-U003	Q2001 or	TR	2SD2394-E	( 1)	2202705	
PCB-U003	Q2002	IC	SI8008TM	1	22242323R2	
PCB-U003	Q2003	TR	KRC102S	1	2216190R2	
PCB-U003	Q2003 or	TR	RN1402	( 1)	2214470R2	
PCB-U003	Q2004	TR	2SC2712-GR	1	2213145R2	
PCB-U003	Q2005	TR	2SA1162-GR	1	2214375R2	
PCB-U003	Q2006	TR	2SA1488-Y	1	2203394	
PCB-U003	Q2006 or	TR	2SB1565-E	( 1)	2202715	
PCB-U003	Q2007	TR	2SD1468S-R	1	2215024T	
PCB-U003	Q2008	IC	79M05L(NJM79M05FA)	1	222790055JRC	
PCB-U003	Q2009	TR	2SC2712-GR	1	2213145R2	
PCB-U003	Q2100	IC	NJW1325	1	22242596R3	N
PCB-U003	Q2100A	SHEET	(VD)	1	29096106	N
PCB-U003	Q2100B	RETAINER	(VD)	1	27142169	N
PCB-U003	Q2500	IC	NE5532APSR	1	22242283R2	
PCB-U003	Q2501	IC	NJM2505AF	1	22242490R2	NO USE from Mark K
PCB-U003	Q2502	IC	NJM2505AF	1	22242490R2	NO USE from Mark K
PCB-U003	Q2503	IC	NJM2505AF	1	22242490R2	
PCB-U003	Q2700	TR	2SA854S-R	1	2217394T	
PCB-U003	Q2700 or	TR	2SB1240-R	( 1)	2213794T	
PCB-U003	Q2701	TR	KRC102S	1	2216190R2	
PCB-U003	Q2701 or	TR	RN1402	( 1)	2214470R2	
PCB-U003	Q2702	TR	2SA1162-GR	1	2214375R2	
PCB-U003	Q2703	TR	KRC102S	1	2216190R2	
PCB-U003	Q2703 or	TR	RN1402	( 1)	2214470R2	
PCB-U003	Q4008	IC	NE5532APSR	1	22242283R2	
PCB-U003	Q4009	IC	NE5532APSR	1	22242283R2	
PCB-U003	Q4010	IC	NE5532APSR	1	22242283R2	
PCB-U003	Q4011	IC	NE5532APSR	1	22242283R2	
PCB-U003	Q4041	IC	NE5532APSR	1	22242283R2	
PCB-U003	Q4043	IC	TC4066BFT	1	22284066MR2TO	



PCB-U003	Q4065	IC	CS3318-CQZR	1	22242404R2	
PCB-U003	Q4066	IC	NJU7312AM	1	22242210R2	
PCB-U003	Q4071	IC	NE5532APSR	1	22242283R2	
PCB-U003	Q4072	IC	NJU7313AM	1	22242211R2	
PCB-U003	Q4074	IC	CS3318-CQZR	1	22242404R2	
PCB-U003	Q4076	IC	NE5532APSR	1	22242283R2	
PCB-U003	Q4080	IC	NJU7312AM	1	22242210R2	
PCB-U003	Q4081	IC	NE5532APSR	1	22242283R2	
PCB-U003	Q4091	IC	NE5532APSR	1	22242283R2	
PCB-U003	Q4101	IC	NE5532APSR	1	22242283R2	
PCB-U003	Q4121	IC	NE5532APSR	1	22242283R2	
PCB-U003	Q4131	IC	NE5532APSR	1	22242283R2	
PCB-U003	Q4151	IC	NE5532APSR	1	22242283R2	
PCB-U003	Q4152	IC	NE5532APSR	1	22242283R2	
PCB-U003	Q4200	TR	2SC2235-Y(TPE6_F)	1	2211654T	
PCB-U003	Q4201	TR	2SA965-Y(TPE6_F)	1	2211644T	
PCB-U003	Q4221	IC	NE5532APSR	1	22242283R2	
PCB-U003	Q4222	TR	RN1402	1	2214470R2	
PCB-U003	Q4223	TR	RN2402	1	2214530R2	
PCB-U003	Q4224	TR	RN1402	1	2214470R2	
PCB-U003	Q4225	TR	RN2402	1	2214530R2	
PCB-U003	Q4226	IC	NJW1112	1	22242597R2	N
PCB-U003	Q4227	IC	NJW1112	1	22242597R2	N
PCB-U003	Q4301	IC	NE5532APSR	1	22242283R2	
PCB-U003	Q4341	IC	NE5532APSR	1	22242283R2	
PCB-U003	Q4342	IC	NE5532APSR	1	22242283R2	
PCB-U003	Q4371	IC	NE5532APSR	1	22242283R2	
PCB-U003	Q4401	TR	2SC2712-GR	1	2213145R2	
PCB-U003	Q4402	TR	2SA950-Y	1	2211504T	
PCB-U003	Q4403	TR	2SA1162-GR	1	2214375R2	
PCB-U003	Q4404	TR	2SC2120-Y	1	2211164T	
PCB-U003	Q4420	TR	RN1402	1	2214470R2	
PCB-U003	Q4421	TR	RN1402	1	2214470R2	

PCB-U003	Q4422	TR	RN1402	1	2214470R2
PCB-U003	Q4423	TR	RN1402	1	2214470R2
PCB-U003	Q4424	TR	RN1402	1	2214470R2
PCB-U003	Q4425	TR	RN1402	1	2214470R2
PCB-U003	Q4441	IC	NE5532APSR	1	22242283R2
PCB-U003	Q4442	TR	2SC2235-Y(TPE6_F)	1	2211654T
PCB-U003	Q4443	TR	2SA965-Y(TPE6_F)	1	2211644T
PCB-U003	Q4444	TR	2SC2235-Y(TPE6_F)	1	2211654T
PCB-U003	Q4445	TR	2SA965-Y(TPE6_F)	1	2211644T
PCB-U003	Q4446	TR	RN1402	1	2214470R2
PCB-U003	Q4446 or	TR	KRC102S	( 1)	2216190R2
PCB-U003	Q4461	IC	NJM4556AM	1	22241414R2
PCB-U003	Q4466	TR	RN1441	1	2215410R2
PCB-U003	Q4467	TR	RN1441	1	2215410R2
PCB-U003	Q4468	TR	2SC2712-GR	1	2213145R2
PCB-U003	Q4640	TR	RN1441	1	2215410R2
PCB-U003	Q4641	TR	RN1441	1	2215410R2
PCB-U003	Q4642	TR	RN1441	1	2215410R2
PCB-U003	Q4643	TR	RN1441	1	2215410R2
PCB-U003	Q4644	TR	RN1441	1	2215410R2
PCB-U003	Q4645	TR	RN1441	1	2215410R2
PCB-U003	Q4646	TR	RN1441	1	2215410R2
PCB-U003	Q4647	TR	RN1441	1	2215410R2
PCB-U003	Q4648	TR	RN1441	1	2215410R2
PCB-U003	Q4741	TR	RN1441	1	2215410R2
PCB-U003	Q4742	TR	RN1441	1	2215410R2
PCB-U003	Q4801	TR	RN1441	1	2215410R2
PCB-U003	Q4802	TR	RN1441	1	2215410R2
PCB-U003	Q4803	TR	RN1441	1	2215410R2
PCB-U003	Q4804	TR	RN1441	1	2215410R2
PCB-U003	<a href="#">[TRANS COIL]</a>				
PCB-U003	L2000	CHOKE COIL	NCH-2541	1	231363K470A
PCB-U003	L2000 or	COIL	0182-7310-470K-RB	( 1)	231389

PCB-U003	L2100	CHOKE COIL	LBC2518T4R7M	1	231364M047R2
PCB-U003	L2101	CHOKE COIL	LBC2518T4R7M	1	231364M047R2
PCB-U003	L2500	CHOKE COIL	LBC2518T4R7M	1	231364M047R2
PCB-U003	L2501	CHOKE COIL	BLM21PG221SN1	1	230949R2
PCB-U003	L2502	CHOKE COIL	BLM21PG221SN1	1	230949R2
PCB-U003	L2504	CHOKE COIL	BLM21PG221SN1	1	230949R2
PCB-U003	L2506	EMIFIL	BK1608LM182-T	1	230958R1
PCB-U003	L2507	EMIFIL	BK1608LM182-T	1	230958R1
PCB-U003	L2508	EMIFIL	BK1608LM182-T	1	230958R1
PCB-U003	L2509	EMIFIL	BK1608LM182-T	1	230958R1
PCB-U003	L2510	EMIFIL	BK1608LM182-T	1	230958R1
PCB-U003	L2511	EMIFIL	BK1608LM182-T	1	230958R1
PCB-U003	L2512	EMIFIL	BK1608LM182-T	1	230958R1
PCB-U003	L2513	EMIFIL	BK1608LM182-T	1	230958R1
PCB-U003	L2514	EMIFIL	BK1608LM182-T	1	230958R1
PCB-U003	L2515	EMIFIL	BK1608LM182-T	1	230958R1
PCB-U003	L2516	EMIFIL	BK1608LM182-T	1	230958R1
PCB-U003	L2517	EMIFIL	BK1608LM182-T	1	230958R1
PCB-U003	L2518	EMIFIL	BK1608LM182-T	1	230958R1
PCB-U003	L2519	EMIFIL	BK1608LM182-T	1	230958R1
PCB-U003	L2520	EMIFIL	BK1608LM182-T	1	230958R1
PCB-U003	L2521	EMIFIL	BK1608LM182-T	1	230958R1
PCB-U003	L2522	EMIFIL	BK1608LM182-T	1	230958R1
PCB-U003	L2523	EMIFIL	BK1608LM182-T	1	230958R1
PCB-U003	L2702	EMIFIL	BK1608LM182-T	1	230958R1
PCB-U003	L2703	EMIFIL	BK1608LM182-T	1	230958R1
PCB-U003	<b>[CAPACITOR]</b>				
PCB-U003	C2000	ELECT C	CE04W18V-10000M(VZ)	1	3945H1037S
PCB-U003	C2002	VR C	CE04W16V-220M(VR)	1	394642217T
PCB-U003	C2003	UTSP C	CE04W50V-10M(UTSP)	1	397581007T
PCB-U003	C2004	VR C	CE04W16V-100M(VR)	1	394641017T
PCB-U003	C2005	VR C	CE04W16V-470M(VR)	1	394644717T
PCB-U003	C2006	VR C	CE04W25V-2200M(VR)	1	394652227S

PCB-U003	C2007	TF C	ECQ-V50V-104J	1	374721044T
PCB-U003	C2008	VR C	CE04W50V-22M(VR)	1	394682207T
PCB-U003	C2009	VR C	CE04W16V-470M(VR)	1	394644717T
PCB-U003	C2010	C-CERA C	CK725F1E-104Z1	1	332161040R1
PCB-U003	C2012	TF C	ECQ-V50V-104J	1	374721044T
PCB-U003	C2013	VR C	CE04W50V-22M(VR)	1	394682207T
PCB-U003	C2014	VR C	CE04W16V-100M(VR)	1	394641017T
PCB-U003	C2015	VR C	CE04W16V-220M(VR)	1	394642217T
PCB-U003	C2016	UTSP C	CE04W50V-10M(UTSP)	1	397581007T
PCB-U003	C2017	VR C	CE04W25V-2200M(VR)	1	394652227S
PCB-U003	C2018	VR C	CE04W50V-4.7M(VR)	1	394680477T
PCB-U003	C2101	C-CERA C	CK725F1A-105Z1	1	332181050R1
PCB-U003	C2103	C-CERA C	CK725F1A-105Z1	1	332181050R1
PCB-U003	C2105	C-CERA C	CK725B0J-225K	1	332092255R1
PCB-U003	C2106	C-CERA C	CK725B1H-102K1	1	332101025R1
PCB-U003	C2108	C-CERA C	CK725F1A-105Z1	1	332181050R1
PCB-U003	C2110	C-CERA C	CK725F1A-105Z1	1	332181050R1
PCB-U003	C2112	C-CERA C	CK725B0J-225K	1	332092255R1
PCB-U003	C2114	C-CERA C	CK725F1A-105Z1	1	332181050R1
PCB-U003	C2116	C-CERA C	CK725F1A-105Z1	1	332181050R1
PCB-U003	C2118	C-CERA C	CK725B0J-225K	1	332092255R1
PCB-U003	C2144	VR C	CE04W35V-47M(VR)	1	394664707T
PCB-U003	C2145	VR C	CE04W35V-47M(VR)	1	394664707T
PCB-U003	C2146	VR C	CE04W35V-47M(VR)	1	394664707T
PCB-U003	C2148	C-CERA C	CK725F1E-104Z1	1	332161040R1
PCB-U003	C2149	C-CERA C	CK725F1E-104Z1	1	332161040R1
PCB-U003	C2150	C-CERA C	CK725F1E-104Z1	1	332161040R1
PCB-U003	C2152	C-CERA C	CK725F1E-104Z1	1	332161040R1
PCB-U003	C2153	C-CERA C	CK725F1E-104Z1	1	332161040R1
PCB-U003	C2154	C-CERA C	CK725F1E-104Z1	1	332161040R1
PCB-U003	C2155	VR C	CE04W35V-47M(VR)	1	394664707T
PCB-U003	C2156	VR C	CE04W35V-47M(VR)	1	394664707T
PCB-U003	C2157	VR C	CE04W35V-47M(VR)	1	394664707T

PCB-U003	C2161	C-CERA C	CK725F1E-104Z1	1	332161040R1
PCB-U003	C2162	VR C	CE04W35V-47M(VR)	1	394664707T
PCB-U003	C2166	VR C	CE04W35V-47M(VR)	1	394664707T
PCB-U003	C2167	C-CERA C	CK725F1E-104Z1	1	332161040R1
PCB-U003	C2169	C-CERA C	CK725F1E-104Z1	1	332161040R1
PCB-U003	C2170	VR C	CE04W50V-1M(VR)	1	394680107T
PCB-U003	C2171	VR C	CE04W50V-1M(VR)	1	394680107T
PCB-U003	C2172	C-CERA C	CK725F1E-104Z1	1	332161040R1
PCB-U003	C2173	C-CERA C	CK725F1E-104Z1	1	332161040R1
PCB-U003	C2174	VR C	CE04W50V-1M(VR)	1	394680107T
PCB-U003	C2175	VR C	CE04W35V-47M(VR)	1	394664707T
PCB-U003	C2176	C-CERA C	CK725F1E-104Z1	1	332161040R1
PCB-U003	C2178	VR C	CE04W35V-47M(VR)	1	394664707T
PCB-U003	C2179	C-CERA C	CK725F1A-105Z1	1	332181050R1
PCB-U003	C2180	C-CERA C	CK725F1E-104Z1	1	332161040R1
PCB-U003	C2182	C-CERA C	CK725B0J-225K	1	332092255R1
PCB-U003	C2184	C-CERA C	CK725B0J-225K	1	332092255R1
PCB-U003	C2185	C-CERA C	CK725B1H-102K1	1	332101025R1
PCB-U003	C2186	VR C	CE04W35V-47M(VR)	1	394664707T
PCB-U003	C2187	C-CERA C	CK725F1E-104Z1	1	332161040R1
PCB-U003	C2189	C-CERA C	CK725F1A-105Z1	1	332181050R1
PCB-U003	C2191	C-CERA C	CK725B0J-225K	1	332092255R1
PCB-U003	C2193	C-CERA C	CK725B0J-225K	1	332092255R1
PCB-U003	C2194	VR C	CE04W35V-47M(VR)	1	394664707T
PCB-U003	C2195	VR C	CE04W35V-47M(VR)	1	394664707T
PCB-U003	C2196	C-CERA C	CK725F1E-104Z1	1	332161040R1
PCB-U003	C2197	C-CERA C	CK725F1E-104Z1	1	332161040R1
PCB-U003	C2198	C-CERA C	CK725F1E-104Z1	1	332161040R1
PCB-U003	C2199	VR C	CE04W35V-47M(VR)	1	394664707T
PCB-U003	C2200	C-CERA C	CC725CH1H-151J1	1	342101514R1
PCB-U003	C2201	C-CERA C	CC725CH1H-151J1	1	342101514R1
PCB-U003	C2202	C-CERA C	CC725CH1H-151J1	1	342101514R1
PCB-U003	C2203	C-CERA C	CK725B1H-102K1	1	332101025R1

PCB-U003	C2205	C-CERA C	CK725F1A-105Z1	1	332181050R1
PCB-U003	C2207	C-CERA C	CK725B0J-225K	1	332092255R1
PCB-U003	C2209	C-CERA C	CK725B0J-225K	1	332092255R1
PCB-U003	C2211	C-CERA C	CK725F1A-105Z1	1	332181050R1
PCB-U003	C2213	C-CERA C	CK725B0J-225K	1	332092255R1
PCB-U003	C2215	C-CERA C	CK725B0J-225K	1	332092255R1
PCB-U003	C2216	C-CERA C	CK725B1H-102K1	1	332101025R1
PCB-U003	C2217	C-CERA C	CC725CH1H-151J1	1	342101514R1
PCB-U003	C2218	C-CERA C	CC725CH1H-151J1	1	342101514R1
PCB-U003	C2219	C-CERA C	CC725CH1H-151J1	1	342101514R1
PCB-U003	C2220	C-CERA C	CC725CH1H-151J1	1	342101514R1
PCB-U003	C2221	C-CERA C	CK725B1H-102K1	1	332101025R1
PCB-U003	C2224	VR C	CE04W50V-1M(VR)	1	394680107T
PCB-U003	C2225	VR C	CE04W50V-4.7M(VR)	1	394680477T
PCB-U003	C2226	VR C	CE04W50V-1M(VR)	1	394680107T
PCB-U003	C2227	VR C	CE04W50V-1M(VR)	1	394680107T
PCB-U003	C2228	VR C	CE04W50V-4.7M(VR)	1	394680477T
PCB-U003	C2229	VR C	CE04W50V-4.7M(VR)	1	394680477T
PCB-U003	C2231	C-CERA C	CK725B0J-225K	1	332092255R1
PCB-U003	C2232	UTSP C	CE04W50V-10M(UTSP)	1	397581007T
PCB-U003	C2233	UTSP C	CE04W50V-10M(UTSP)	1	397581007T
PCB-U003	C2237	C-CERA C	CK725B0J-225K	1	332092255R1
PCB-U003	C2238	C-CERA C	CK725B0J-225K	1	332092255R1
PCB-U003	C2239	C-CERA C	CK725B0J-225K	1	332092255R1
PCB-U003	C2240	C-CERA C	CK725B0J-225K	1	332092255R1
PCB-U003	C2241	C-CERA C	CK725B0J-225K	1	332092255R1
PCB-U003	C2242	C-CERA C	CK725B0J-225K	1	332092255R1
PCB-U003	C2243	C-CERA C	CK725B0J-225K	1	332092255R1
PCB-U003	C2244	C-CERA C	CK725B0J-225K	1	332092255R1
PCB-U003	C2245	C-CERA C	CK725B0J-225K	1	332092255R1
PCB-U003	C2246	C-CERA C	CK725B0J-225K	1	332092255R1
PCB-U003	C2247	C-CERA C	CK725B0J-225K	1	332092255R1
PCB-U003	C2248	C-CERA C	CK725B0J-225K	1	332092255R1

PCB-U003	C2501	UTSP C	CE04W50V-10M(UTSP)	1	397581007T	
PCB-U003	C2502	VR C	CE04W35V-100M(VR)	1	394661017T	
PCB-U003	C2504	C-CERA C	CC725CH1H-471J1	1	342104714R1	
PCB-U003	C2505	VR C	CE04W35V-100M(VR)	1	394661017T	
PCB-U003	C2506	C-CERA C	CC725CH1H-471J1	1	342104714R1	
PCB-U003	C2507	UTSP C	CE04W50V-10M(UTSP)	1	397581007T	
PCB-U003	C2509	UTSP C	CE04W50V-10M(UTSP)	1	397581007T	NO USE from Mark K
PCB-U003	C2510	VR C	CE04W6.3V-470M(VR)	1	394624717T	NO USE from Mark K
PCB-U003	C2511	VR C	CE04W6.3V-470M(VR)	1	394624717T	NO USE from Mark K
PCB-U003	C2512	VR C	CE04W16V-100M(VR)	1	394641017T	NO USE from Mark K
PCB-U003	C2513	C-CERA C	CK725F1E-104Z1	1	332161040R1	NO USE from Mark K
PCB-U003	C2514	C-CERA C	CK725B1H-102K1	1	332101025R1	
PCB-U003	C2515	C-CERA C	CK725B1H-102K1	1	332101025R1	
PCB-U003	C2516	UTSP C	CE04W50V-10M(UTSP)	1	397581007T	NO USE from Mark K
PCB-U003	C2517	VR C	CE04W6.3V-470M(VR)	1	394624717T	NO USE from Mark K
PCB-U003	C2518	VR C	CE04W6.3V-470M(VR)	1	394624717T	NO USE from Mark K
PCB-U003	C2519	VR C	CE04W16V-100M(VR)	1	394641017T	NO USE from Mark K
PCB-U003	C2520	C-CERA C	CK725F1E-104Z1	1	332161040R1	NO USE from Mark K
PCB-U003	C2521	C-CERA C	CK725B1H-102K1	1	332101025R1	
PCB-U003	C2522	C-CERA C	CC725CH1H-470J1	1	342104704R1	
PCB-U003	C2523	UTSP C	CE04W50V-10M(UTSP)	1	397581007T	
PCB-U003	C2524	VR C	CE04W6.3V-470M(VR)	1	394624717T	
PCB-U003	C2525	VR C	CE04W6.3V-470M(VR)	1	394624717T	
PCB-U003	C2526	C-CERA C	CK725B1H-102K1	1	332101025R1	
PCB-U003	C2527	C-CERA C	CC725CH1H-470J1	1	342104704R1	
PCB-U003	C2528	VR C	CE04W16V-100M(VR)	1	394641017T	
PCB-U003	C2529	C-CERA C	CK725F1E-104Z1	1	332161040R1	
PCB-U003	C2530	C-CERA C	CK725B1H-102K1	1	332101025R1	
PCB-U003	C2531	C-CERA C	CK725F1E-104Z1	1	332161040R1	
PCB-U003	C2532	C-CERA C	CC725CH1H-470J1	1	342104704R1	
PCB-U003	C2533	C-CERA C	CC725CH1H-101J1	1	342101014R1	
PCB-U003	C2534	UTSP C	CE04W50V-10M(UTSP)	1	397581007T	
PCB-U003	C2535	C-CERA C	CC725CH1H-101J1	1	342101014R1	

PCB-U003	C2536	UTSP C	CE04W50V-10M(UTSP)	1	397581007T	
PCB-U003	C2537	C-CERA C	CC725CH1H-101J1	1	342101014R1	
PCB-U003	C2538	C-CERA C	CC725CH1H-101J1	1	342101014R1	
PCB-U003	C2539	C-CERA C	CK725F1E-104Z1	1	332161040R1	
PCB-U003	C2540	C-CERA C	CC725CH1H-470J1	1	342104704R1	NO USE from Mark K
PCB-U003	C2541	C-CERA C	CC725CH1H-470J1	1	342104704R1	NO USE from Mark K
PCB-U003	C2542	C-CERA C	CC725CH1H-470J1	1	342104704R1	NO USE from Mark K
PCB-U003	C2543	C-CERA C	CC725CH1H-470J1	1	342104704R1	NO USE from Mark K
PCB-U003	C2544	C-CERA C	CC725CH1H-470J1	1	342104704R1	
PCB-U003	C2545	C-CERA C	CC725CH1H-470J1	1	342104704R1	
PCB-U003	C2546	C-CERA C	CC725CH1H-221J1	1	342102214R1	
PCB-U003	C2547	C-CERA C	CC725CH1H-221J1	1	342102214R1	
PCB-U003	C2700	VR C	CE04W6.3V-220M(VR)	1	394622217T	
PCB-U003	C2701	C-CERA C	CK725B1H-102K1	1	332101025R1	
PCB-U003	C2704	C-CERA C	CC725CH1H-101J1	1	342101014R1	
PCB-U003	C2705	C-CERA C	CK725F1E-104Z1	1	332161040R1	
PCB-U003	C2707	C-CERA C	CC725CH1H-101J1	1	342101014R1	
PCB-U003	C4001	UPZ C	2AUPZTF221JE	1	376332214T	
PCB-U003	C4002	UPZ C	2AUPZTF221JE	1	376332214T	
PCB-U003	C4023	MKT C	B32529C0102J289	1	376491024T	
PCB-U003	C4031	UTSP C	CE04W50V-100M(UTSP)	1	397581017T	
PCB-U003	C4032	UTSP C	CE04W50V-100M(UTSP)	1	397581017T	
PCB-U003	C4041	UPZ C	2AUPZTF221JE	1	376332214T	
PCB-U003	C4042	UPZ C	2AUPZTF221JE	1	376332214T	
PCB-U003	C4043	UTSP C	CE04W50V 47M(UTSP)	1	397584707T	
PCB-U003	C4044	UTSP C	CE04W50V 47M(UTSP)	1	397584707T	
PCB-U003	C4045	UTSP C	CE04W50V-100M(UTSP)	1	397581017T	
PCB-U003	C4046	UTSP C	CE04W50V-100M(UTSP)	1	397581017T	
PCB-U003	C4060	MKT C	B32529C0102J289	1	376491024T	
PCB-U003	C4061	C-CERA C	CC725CH1H-221J1	1	342102214R1	
PCB-U003	C4062	C-CERA C	CC725CH1H-221J1	1	342102214R1	
PCB-U003	C4071	C-CERA C	CC725CH1H-221J1	1	342102214R1	
PCB-U003	C4072	C-CERA C	CC725CH1H-221J1	1	342102214R1	



PCB-U003	C4073	UTSP C	CE04W50V 47M(UTSP)	1	397584707T
PCB-U003	C4074	UTSP C	CE04W50V 47M(UTSP)	1	397584707T
PCB-U003	C4075	UTSP C	CE04W50V-100M(UTSP)	1	397581017T
PCB-U003	C4076	UTSP C	CE04W50V-100M(UTSP)	1	397581017T
PCB-U003	C4080	MKT C	B32529C0102J289	1	376491024T
PCB-U003	C4081	C-CERA C	CC725CH1H-221J1	1	342102214R1
PCB-U003	C4082	C-CERA C	CC725CH1H-221J1	1	342102214R1
PCB-U003	C4083	UTSP C	CE04W50V 47M(UTSP)	1	397584707T
PCB-U003	C4084	UTSP C	CE04W50V 47M(UTSP)	1	397584707T
PCB-U003	C4090	MKT C	B32529C0102J289	1	376491024T
PCB-U003	C4091	C-CERA C	CC725CH1H-221J1	1	342102214R1
PCB-U003	C4092	C-CERA C	CC725CH1H-221J1	1	342102214R1
PCB-U003	C4093	UTSP C	CE04W50V 47M(UTSP)	1	397584707T
PCB-U003	C4094	UTSP C	CE04W50V 47M(UTSP)	1	397584707T
PCB-U003	C4101	C-CERA C	CC725CH1H-221J1	1	342102214R1
PCB-U003	C4102	C-CERA C	CC725CH1H-221J1	1	342102214R1
PCB-U003	C4103	UTSP C	CE04W50V 47M(UTSP)	1	397584707T
PCB-U003	C4104	UTSP C	CE04W50V 47M(UTSP)	1	397584707T
PCB-U003	C4110	MKT C	B32529C0102J289	1	376491024T
PCB-U003	C4111	C-CERA C	CC725CH1H-221J1	1	342102214R1
PCB-U003	C4112	C-CERA C	CC725CH1H-221J1	1	342102214R1
PCB-U003	C4121	C-CERA C	CC725CH1H-221J1	1	342102214R1
PCB-U003	C4122	C-CERA C	CC725CH1H-221J1	1	342102214R1
PCB-U003	C4123	UTSP C	CE04W50V 47M(UTSP)	1	397584707T
PCB-U003	C4124	UTSP C	CE04W50V 47M(UTSP)	1	397584707T
PCB-U003	C4131	UPZ C	2AUPZTF221JE	1	376332214T
PCB-U003	C4132	UPZ C	2AUPZTF221JE	1	376332214T
PCB-U003	C4133	UTSP C	CE04W50V 47M(UTSP)	1	397584707T
PCB-U003	C4134	UTSP C	CE04W50V 47M(UTSP)	1	397584707T
PCB-U003	C4135	UTSP C	CE04W50V-100M(UTSP)	1	397581017T
PCB-U003	C4136	UTSP C	CE04W50V-100M(UTSP)	1	397581017T
PCB-U003	C4151	UTSP C	CE04W50V 47M(UTSP)	1	397584707T
PCB-U003	C4152	UTSP C	CE04W50V 47M(UTSP)	1	397584707T

PCB-U003	C4153	UTSP C	CE04W50V 47M(UTSP)	1	397584707T
PCB-U003	C4154	UTSP C	CE04W50V 47M(UTSP)	1	397584707T
PCB-U003	C4155	UTSP C	CE04W50V 47M(UTSP)	1	397584707T
PCB-U003	C4156	UTSP C	CE04W50V 47M(UTSP)	1	397584707T
PCB-U003	C4157	UTSP C	CE04W50V 47M(UTSP)	1	397584707T
PCB-U003	C4158	UTSP C	CE04W50V 47M(UTSP)	1	397584707T
PCB-U003	C4200	UTSP C	CE04W50V-10M(UTSP)	1	397581007T
PCB-U003	C4201	UTSP C	CE04W25V-100M(UTSP)	1	397551017T
PCB-U003	C4202	UTSP C	CE04W25V-100M(UTSP)	1	397551017T
PCB-U003	C4203	UTSP C	CE04W50V-10M(UTSP)	1	397581007T
PCB-U003	C4204	UTSP C	CE04W25V-100M(UTSP)	1	397551017T
PCB-U003	C4205	UTSP C	CE04W25V-100M(UTSP)	1	397551017T
PCB-U003	C4206	UTSP C	CE04W25V-220M(UTSP)	1	397552217T
PCB-U003	C4207	UTSP C	CE04W25V-220M(UTSP)	1	397552217T
PCB-U003	C4208	UTSP C	CE04W50V 47M(UTSP)	1	397584707T
PCB-U003	C4209	UTSP C	CE04W50V 47M(UTSP)	1	397584707T
PCB-U003	C4210	UTSP C	CE04W25V-220M(UTSP)	1	397552217T
PCB-U003	C4211	UTSP C	CE04W25V-220M(UTSP)	1	397552217T
PCB-U003	C4221	UTSP C	CE04W50V 47M(UTSP)	1	397584707T
PCB-U003	C4222	UTSP C	CE04W50V 47M(UTSP)	1	397584707T
PCB-U003	C4223	UTSP C	CE04W50V 47M(UTSP)	1	397584707T
PCB-U003	C4224	UTSP C	CE04W50V 47M(UTSP)	1	397584707T
PCB-U003	C4225	C-CERA C	CK725F1E-104Z1	1	332161040R1
PCB-U003	C4226	C-CERA C	CK725F1E-104Z1	1	332161040R1
PCB-U003	C4243	MKT C	B32529C0102J289	1	376491024T
PCB-U003	C4244	C-CERA C	CC725CH1H-102J1	1	342101024R1
PCB-U003	C4303	UTSP C	CE04W50V-1M(UTSP)	1	397580107T
PCB-U003	C4304	C-CERA C	CK725F1C-224Z1	1	332172240R1
PCB-U003	C4305	UTSP C	CE04W50V 47M(UTSP)	1	397584707T
PCB-U003	C4345	UTSP C	CE04W50V 47M(UTSP)	1	397584707T
PCB-U003	C4346	UTSP C	CE04W50V 47M(UTSP)	1	397584707T
PCB-U003	C4373	UTSP C	CE04W50V 47M(UTSP)	1	397584707T
PCB-U003	C4374	UTSP C	CE04W50V 47M(UTSP)	1	397584707T

PCB-U003	C4384	UTSP C	CE04W50V 47M(UTSP)	1	397584707T
PCB-U003	C4391	UTSP C	CE04W50V-100M(UTSP)	1	397581017T
PCB-U003	C4392	UTSP C	CE04W50V-100M(UTSP)	1	397581017T
PCB-U003	C4402	UTSP C	CE04W25V-100M(UTSP)	1	397551017T
PCB-U003	C4403	UTSP C	CE04W25V-100M(UTSP)	1	397551017T
PCB-U003	C4404	UTSP C	CE04W50V 47M(UTSP)	1	397584707T
PCB-U003	C4405	UTSP C	CE04W50V 47M(UTSP)	1	397584707T
PCB-U003	C4406	UTSP C	CE04W25V-220M(UTSP)	1	397552217T
PCB-U003	C4407	UTSP C	CE04W25V-220M(UTSP)	1	397552217T
PCB-U003	C4408	UTSP C	CE04W50V 47M(UTSP)	1	397584707T
PCB-U003	C4409	UTSP C	CE04W50V-10M(UTSP)	1	397581007T
PCB-U003	C4410	UTSP C	CE04W50V-10M(UTSP)	1	397581007T
PCB-U003	C4411	UTSP C	CE04W50V-10M(UTSP)	1	397581007T
PCB-U003	C4412	UTSP C	CE04W50V-10M(UTSP)	1	397581007T
PCB-U003	C4417	C-CERA C	CC725CH1H-101J1	1	342101014R1
PCB-U003	C4418	C-CERA C	CC725CH1H-101J1	1	342101014R1
PCB-U003	C4419	C-CERA C	CC725CH1H-101J1	1	342101014R1
PCB-U003	C4420	C-CERA C	CK725F1E-104Z1	1	332161040R1
PCB-U003	C4421	C-CERA C	CK725F1E-104Z1	1	332161040R1
PCB-U003	C4422	C-CERA C	CC725CH1H-101J1	1	342101014R1
PCB-U003	C4423	C-CERA C	CC725CH1H-101J1	1	342101014R1
PCB-U003	C4424	C-CERA C	CC725CH1H-101J1	1	342101014R1
PCB-U003	C4431	TF C	ECQ-V50V-104J	1	374721044T
PCB-U003	C4432	TF C	ECQ-V50V-104J	1	374721044T
PCB-U003	C4433	TF C	ECQ-V50V-104J	1	374721044T
PCB-U003	C4434	TF C	ECQ-V50V-104J	1	374721044T
PCB-U003	C4435	TF C	ECQ-V50V-104J	1	374721044T
PCB-U003	C4436	TF C	ECQ-V50V-104J	1	374721044T
PCB-U003	C4441	UTSP C	CE04W50V 47M(UTSP)	1	397584707T
PCB-U003	C4442	UTSP C	CE04W50V 47M(UTSP)	1	397584707T
PCB-U003	C4443	C-CERA C	CC725CH1H-102J1	1	342101024R1
PCB-U003	C4444	C-CERA C	CC725CH1H-102J1	1	342101024R1
PCB-U003	C4445	TF C	ECQ-V50V-104J	1	374721044T

PCB-U003	C4461	UTSP C	CE04W50V 47M(UTSP)	1	397584707T
PCB-U003	C4462	UTSP C	CE04W50V 47M(UTSP)	1	397584707T
PCB-U003	C4463	C-CERA C	CC725CH1H-101J1	1	342101014R1
PCB-U003	C4464	C-CERA C	CC725CH1H-101J1	1	342101014R1
PCB-U003	C4465	UTSP C	CE04W50V 47M(UTSP)	1	397584707T
PCB-U003	C4466	UTSP C	CE04W50V 47M(UTSP)	1	397584707T
PCB-U003	C4467	TF C	ECQ-V50V-104J	1	374721044T
PCB-U003	C4550	C-CERA C	CK725B1H-103K1	1	332101035R1
PCB-U003	C4552	TF C	ECQ-V50V-104J	1	374721044T
PCB-U003	C4600	C-CERA C	CC725CH1H-221J1	1	342102214R1
PCB-U003	C4601	C-CERA C	CC725CH1H-221J1	1	342102214R1
PCB-U003	C4602	C-CERA C	CC725CH1H-221J1	1	342102214R1
PCB-U003	C4603	C-CERA C	CC725CH1H-221J1	1	342102214R1
PCB-U003	C4604	C-CERA C	CC725CH1H-221J1	1	342102214R1
PCB-U003	C4605	C-CERA C	CC725CH1H-221J1	1	342102214R1
PCB-U003	C4606	C-CERA C	CC725CH1H-221J1	1	342102214R1
PCB-U003	C4607	C-CERA C	CC725CH1H-221J1	1	342102214R1
PCB-U003	C4608	MKT C	B32529C0102J289	1	376491024T
PCB-U003	C4610	UTSP C	CE04W50V 47M(UTSP)	1	397584707T
PCB-U003	C4611	UTSP C	CE04W50V 47M(UTSP)	1	397584707T
PCB-U003	C4612	UTSP C	CE04W50V 47M(UTSP)	1	397584707T
PCB-U003	C4613	UTSP C	CE04W50V 47M(UTSP)	1	397584707T
PCB-U003	C4614	UTSP C	CE04W50V 47M(UTSP)	1	397584707T
PCB-U003	C4615	UTSP C	CE04W50V 47M(UTSP)	1	397584707T
PCB-U003	C4616	UTSP C	CE04W50V 47M(UTSP)	1	397584707T
PCB-U003	C4617	UTSP C	CE04W50V 47M(UTSP)	1	397584707T
PCB-U003	C4620	UTSP C	CE04W50V 47M(UTSP)	1	397584707T
PCB-U003	C4621	MKT C	B32529C0102J289	1	376491024T
PCB-U003	C4633	UTSP C	CE04W50V 47M(UTSP)	1	397584707T
PCB-U003	C4634	UTSP C	CE04W50V 47M(UTSP)	1	397584707T
PCB-U003	C4635	UTSP C	CE04W50V 47M(UTSP)	1	397584707T
PCB-U003	C4636	UTSP C	CE04W50V 47M(UTSP)	1	397584707T
PCB-U003	C4637	UTSP C	CE04W50V 47M(UTSP)	1	397584707T

PCB-U003	C4640	UTSP C	CE04W50V 47M(UTSP)	1	397584707T
PCB-U003	C4641	UTSP C	CE04W50V 47M(UTSP)	1	397584707T
PCB-U003	C4642	UTSP C	CE04W50V 47M(UTSP)	1	397584707T
PCB-U003	C4643	UTSP C	CE04W50V 47M(UTSP)	1	397584707T
PCB-U003	C4644	UTSP C	CE04W50V 47M(UTSP)	1	397584707T
PCB-U003	C4645	UTSP C	CE04W50V 47M(UTSP)	1	397584707T
PCB-U003	C4646	UTSP C	CE04W50V 47M(UTSP)	1	397584707T
PCB-U003	C4647	UTSP C	CE04W50V-10M(UTSP)	1	397581007T
PCB-U003	C4648	UTSP C	CE04W50V-10M(UTSP)	1	397581007T
PCB-U003	C4650	C-CERA C	CC725CH1H-221J1	1	342102214R1
PCB-U003	C4651	C-CERA C	CC725CH1H-221J1	1	342102214R1
PCB-U003	C4652	C-CERA C	CC725CH1H-221J1	1	342102214R1
PCB-U003	C4653	C-CERA C	CC725CH1H-221J1	1	342102214R1
PCB-U003	C4654	C-CERA C	CC725CH1H-221J1	1	342102214R1
PCB-U003	C4655	C-CERA C	CC725CH1H-221J1	1	342102214R1
PCB-U003	C4656	C-CERA C	CC725CH1H-221J1	1	342102214R1
PCB-U003	C4657	C-CERA C	CC725CH1H-221J1	1	342102214R1
PCB-U003	C4658	C-CERA C	CC725CH1H-221J1	1	342102214R1
PCB-U003	C4741	UTSP C	CE04W50V 47M(UTSP)	1	397584707T
PCB-U003	C4742	UTSP C	CE04W50V 47M(UTSP)	1	397584707T
PCB-U003	C4751	C-CERA C	CC725CH1H-221J1	1	342102214R1
PCB-U003	C4752	C-CERA C	CC725CH1H-221J1	1	342102214R1
PCB-U003	C4801	UTSP C	CE04W50V 47M(UTSP)	1	397584707T
PCB-U003	C4802	UTSP C	CE04W50V 47M(UTSP)	1	397584707T
PCB-U003	C4803	UTSP C	CE04W50V 47M(UTSP)	1	397584707T
PCB-U003	C4804	UTSP C	CE04W50V 47M(UTSP)	1	397584707T
PCB-U003	C4811	C-CERA C	CC725CH1H-221J1	1	342102214R1
PCB-U003	C4812	C-CERA C	CC725CH1H-221J1	1	342102214R1
PCB-U003	C4813	C-CERA C	CC725CH1H-221J1	1	342102214R1
PCB-U003	C4814	C-CERA C	CC725CH1H-221J1	1	342102214R1
PCB-U003	[RESISTOR]				
PCB-U003	R2000	C-CARBON R	RN72K1J-222JE	1	435032224R1
PCB-U003	R2001	METAL R	RNU1/2WCJ-0.22	1	453532294T

PCB-U003	R2002	C-CARBON R	RN72K1J-472JE	1	435034724R1
PCB-U003	R2003	C-CARBON R	RN72K1J-152JE	1	435031524R1
PCB-U003	R2004	C-CARBON R	RN72K1J-221JE	1	435032214R1
PCB-U003	R2005	C-CARBON R	RN72K1J-392JE	1	435033924R1
PCB-U003	R2006	C-CARBON R	RN72K1J-102JE	1	435031024R1
PCB-U003	R2007	C-CARBON R	RN72K1J-221JE	1	435032214R1
PCB-U003	R2008	C-CARBON R	RN72K1J-222JE	1	435032224R1
PCB-U003	R2009	C-CARBON R	RN72K1J-473JE	1	435034734R1
PCB-U003	R2010	METAL R	RNU2WCJ-4.7	1	452730474F
PCB-U003	R2011	METAL R	RNU2WCJ-4.7	1	452730474F
PCB-U003	R2013	C-CARBON R	RN72K2E-015JE	1	435220154R1
PCB-U003	R2014	METAL R	RNU1/2WCJ-0.22	1	453532294T
PCB-U003	R2017	C-CARBON R	RN72K1J-472JE	1	435034724R1
PCB-U003	R2018	C-CARBON R	RN72K1J-103JE	1	435031034R1
PCB-U003	R2020	C-CARBON R	RN72K1J-222JE	1	435032224R1
PCB-U003	R2024	C-CARBON R	RN72K1J-000JE	1	435030004R1
PCB-U003	R2025	C-CARBON R	RN72K1J-000JE	1	435030004R1
PCB-U003	R2026	C-CARBON R	RN72K1J-000JE	1	435030004R1
PCB-U003	R2027	C-CARBON R	RN72K1J-000JE	1	435030004R1
PCB-U003	R2028	C-CARBON R	RN72K1J-000JE	1	435030004R1
PCB-U003	R2029	C-CARBON R	RN72K1J-000JE	1	435030004R1
PCB-U003	R2030	C-CARBON R	RN72K1J-104JE	1	435031044R1
PCB-U003	R2031	C-CARBON R	RN72K1J-562JE	1	435035624R1
PCB-U003	R2100	C-CARBON R	RN72K1J-750JE	1	435037504R1
PCB-U003	R2101	C-CARBON R	RN72K1J-750JE	1	435037504R1
PCB-U003	R2102	C-CARBON R	RN72K1J-750JE	1	435037504R1
PCB-U003	R2104	C-CARBON R	RN72K1J-750JE	1	435037504R1
PCB-U003	R2105	C-CARBON R	RN72K1J-750JE	1	435037504R1
PCB-U003	R2106	C-CARBON R	RN72K1J-750JE	1	435037504R1
PCB-U003	R2107	C-CARBON R	RN72K1J-750JE	1	435037504R1
PCB-U003	R2111	C-CARBON R	RN72K1J-750JE	1	435037504R1
PCB-U003	R2112	C-CARBON R	RN72K1J-000JE	1	435030004R1
PCB-U003	R2116	C-CARBON R	RN72K1J-750JE	1	435037504R1

PCB-U003	R2117	C-CARBON R	RN72K1J-000JE	1	435030004R1
PCB-U003	R2118	C-CARBON R	RN72K1J-000JE	1	435030004R1
PCB-U003	R2119	C-CARBON R	RN72K1J-000JE	1	435030004R1
PCB-U003	R2120	C-CARBON R	RN72K1J-000JE	1	435030004R1
PCB-U003	R2121	C-CARBON R	RN72K1J-000JE	1	435030004R1
PCB-U003	R2122	C-CARBON R	RN72K1J-750JE	1	435037504R1
PCB-U003	R2123	C-CARBON R	RN72K1J-104JE	1	435031044R1
PCB-U003	R2135	C-CARBON R	RN72K1J-750JE	1	435037504R1
PCB-U003	R2136	C-CARBON R	RN72K1J-104JE	1	435031044R1
PCB-U003	R2147	C-CARBON R	RN72K1J-750JE	1	435037504R1
PCB-U003	R2148	C-CARBON R	RN72K1J-104JE	1	435031044R1
PCB-U003	R2158	C-CARBON R	RN72K1J-103JE	1	435031034R1
PCB-U003	R2159	C-CARBON R	RN72K1J-103JE	1	435031034R1
PCB-U003	R2165	C-CARBON R	RN72K1J-104JE	1	435031044R1
PCB-U003	R2166	C-CARBON R	RN72K1J-104JE	1	435031044R1
PCB-U003	R2168	C-CARBON R	RN72K1J-104JE	1	435031044R1
PCB-U003	R2169	C-CARBON R	RN72K1J-104JE	1	435031044R1
PCB-U003	R2171	C-CARBON R	RN72K1J-104JE	1	435031044R1
PCB-U003	R2172	C-CARBON R	RN72K1J-104JE	1	435031044R1
PCB-U003	R2173	C-CARBON R	RN72K1J-750JE	1	435037504R1
PCB-U003	R2174	C-CARBON R	RN72K1J-750JE	1	435037504R1
PCB-U003	R2175	C-CARBON R	RN72K1J-750JE	1	435037504R1
PCB-U003	R2176	C-CARBON R	RN72K1J-103JE	1	435031034R1
PCB-U003	R2179	C-CARBON R	RN72K1J-750JE	1	435037504R1
PCB-U003	R2180	C-CARBON R	RN72K1J-750JE	1	435037504R1
PCB-U003	R2181	C-CARBON R	RN72K1J-750JE	1	435037504R1
PCB-U003	R2186	C-CARBON R	RN72K1J-750JE	1	435037504R1
PCB-U003	R2189	C-CARBON R	RN72K1J-750JE	1	435037504R1
PCB-U003	R2190	METAL R	RNU1/2WCJ-0.1	1	453531094T
PCB-U003	R2191	METAL R	RNU1/2WCJ-0.1	1	453531094T
PCB-U003	R2192	C-CARBON R	RN72K1J-750JE	1	435037504R1
PCB-U003	R2193	C-CARBON R	RN72K1J-392JE	1	435033924R1
PCB-U003	R2194	C-CARBON R	RN72K1J-104JE	1	435031044R1

PCB-U003	R2195	C-CARBON R	RN72K1J-104JE	1	435031044R1	
PCB-U003	R2196	C-CARBON R	RN72K1J-104JE	1	435031044R1	
PCB-U003	R2197	C-CARBON R	RN72K1J-392JE	1	435033924R1	
PCB-U003	R2198	C-CARBON R	RN72K1J-750JE	1	435037504R1	
PCB-U003	R2199	C-CARBON R	RN72K1J-750JE	1	435037504R1	
PCB-U003	R2200	C-CARBON R	RN72K1J-750JE	1	435037504R1	
PCB-U003	R2201	C-CARBON R	RN72K1J-750JE	1	435037504R1	
PCB-U003	R2202	C-CARBON R	RN72K1J-750JE	1	435037504R1	
PCB-U003	R2203	C-CARBON R	RN72K1J-750JE	1	435037504R1	
PCB-U003	R2204	C-CARBON R	RN72K1J-750JE	1	435037504R1	
PCB-U003	R2205	C-CARBON R	RN72K1J-750JE	1	435037504R1	
PCB-U003	R2206	C-CARBON R	RN72K1J-750JE	1	435037504R1	
PCB-U003	R2207	C-CARBON R	RN72K1J-104JE	1	435031044R1	
PCB-U003	R2208	C-CARBON R	RN72K1J-104JE	1	435031044R1	
PCB-U003	R2209	C-CARBON R	RN72K1J-104JE	1	435031044R1	
PCB-U003	R2210	C-CARBON R	RN72K1J-750JE	1	435037504R1	
PCB-U003	R2211	C-CARBON R	RN72K1J-104JE	1	435031044R1	
PCB-U003	R2222	C-CARBON R	RN72K1J-000JE	1	435030004R1	
PCB-U003	R2223	C-CARBON R	RN72K1J-000JE	1	435030004R1	
PCB-U003	R2224	C-CARBON R	RN72K1J-000JE	1	435030004R1	
PCB-U003	R2500	C-CARBON R	RN72K1J-220JE	1	435032204R1	
PCB-U003	R2501	C-CARBON R	RN72K1J-223JE	1	435032234R1	
PCB-U003	R2504	C-CARBON R	RN72K1J-223JE	1	435032234R1	
PCB-U003	R2505	C-CARBON R	RN72K1J-223JE	1	435032234R1	
PCB-U003	R2506	C-CARBON R	RN72K1J-223JE	1	435032234R1	
PCB-U003	R2507	C-CARBON R	RN72K1J-223JE	1	435032234R1	
PCB-U003	R2508	C-CARBON R	RN72K1J-223JE	1	435032234R1	
PCB-U003	R2510	C-CARBON R	RN72K1J-223JE	1	435032234R1	
PCB-U003	R2512	C-CARBON R	RN72K1J-223JE	1	435032234R1	
PCB-U003	R2513	C-CARBON R	RN72K1J-220JE	1	435032204R1	
PCB-U003	R2515	C-CARBON R	RN72K1J-220JE	1	435032204R1	NO USE from Mark K
PCB-U003	R2516	C-CARBON R	RN72K1J-750JE	1	435037504R1	
PCB-U003	R2517	C-CARBON R	RN72K1J-222JE	1	435032224R1	



PCB-U003	R2518	C-CARBON R	RN72K1J-022JE	1	435030224R1	NO USE from Mark K
PCB-U003	R2519	C-CARBON R	RN72K1J-220JE	1	435032204R1	NO USE from Mark K
PCB-U003	R2521	C-CARBON R	RN72K1J-220JE	1	435032204R1	NO USE from Mark K
PCB-U003	R2522	C-CARBON R	RN72K1J-750JE	1	435037504R1	
PCB-U003	R2523	C-CARBON R	RN72K1J-222JE	1	435032224R1	
PCB-U003	R2524	C-CARBON R	RN72K1J-022JE	1	435030224R1	NO USE from Mark K
PCB-U003	R2525	C-CARBON R	RN72K1J-220JE	1	435032204R1	NO USE from Mark K
PCB-U003	R2528	C-CARBON R	RN72K1J-220JE	1	435032204R1	
PCB-U003	R2529	C-CARBON R	RN72K1J-750JE	1	435037504R1	
PCB-U003	R2530	C-CARBON R	RN72K1J-222JE	1	435032224R1	
PCB-U003	R2531	C-CARBON R	RN72K1J-022JE	1	435030224R1	
PCB-U003	R2532	C-CARBON R	RN72K1J-220JE	1	435032204R1	
PCB-U003	R2533	C-CARBON R	RN72K1J-471JE	1	435034714R1	
PCB-U003	R2534	C-CARBON R	RN72K1J-471JE	1	435034714R1	
PCB-U003	R2535	C-CARBON R	RN72K1J-105JE	1	435031054R1	
PCB-U003	R2536	C-CARBON R	RN72K1J-105JE	1	435031054R1	
PCB-U003	R2537	THERMISTOR	FUSB090F	1	4000252T	
PCB-U003	R2700	C-CARBON R	RN72K1J-101JE	1	435031014R1	
PCB-U003	R2701	C-CARBON R	RN72K1J-102JE	1	435031024R1	
PCB-U003	R2702	C-CARBON R	RN72K1J-039JE	1	435030394R1	
PCB-U003	R2703	C-CARBON R	RN72K1J-224JE	1	435032244R1	
PCB-U003	R2704	C-CARBON R	RN72K1J-102JE	1	435031024R1	
PCB-U003	R2705	C-CARBON R	RN72K1J-220JE	1	435032204R1	
PCB-U003	R2707	C-CARBON R	RN72K1J-224JE	1	435032244R1	
PCB-U003	R2708	C-CARBON R	RN72K1J-102JE	1	435031024R1	
PCB-U003	R2710	C-CARBON R	RN72K1J-101JE	1	435031014R1	
PCB-U003	R2714	C-CARBON R	RN72K1J-000JE	1	435030004R1	
PCB-U003	R2715	C-CARBON R	RN72K1J-000JE	1	435030004R1	
PCB-U003	R2716	C-CARBON R	RN72K1J-000JE	1	435030004R1	
PCB-U003	R2718	C-CARBON R	RN72K1J-000JE	1	435030004R1	
PCB-U003	R4001	C-CARBON R	RN72K1J-562JE	1	435035624R1	
PCB-U003	R4002	C-CARBON R	RN72K1J-562JE	1	435035624R1	
PCB-U003	R4003	C-CARBON R	RN72K1J-563JE	1	435035634R1	

PCB-U003	R4004	C-CARBON R	RN72K1J-563JE	1	435035634R1
PCB-U003	R4041	C-CARBON R	RN72K1J-331JE	1	435033314R1
PCB-U003	R4042	C-CARBON R	RN72K1J-331JE	1	435033314R1
PCB-U003	R4043	C-CARBON R	RN72K1J-563JE	1	435035634R1
PCB-U003	R4044	C-CARBON R	RN72K1J-563JE	1	435035634R1
PCB-U003	R4045	C-CARBON R	RN72K1J-224JE	1	435032244R1
PCB-U003	R4046	C-CARBON R	RN72K1J-224JE	1	435032244R1
PCB-U003	R4047	METAL O R	RS1/2WBJ-22	1	443522204T
PCB-U003	R4048	METAL O R	RS1/2WBJ-22	1	443522204T
PCB-U003	R4061	C-CARBON R	RN72K1J-331JE	1	435033314R1
PCB-U003	R4062	C-CARBON R	RN72K1J-331JE	1	435033314R1
PCB-U003	R4063	C-CARBON R	RN72K1J-224JE	1	435032244R1
PCB-U003	R4064	C-CARBON R	RN72K1J-224JE	1	435032244R1
PCB-U003	R4065	C-CARBON R	RN72K1J-100JE	1	435031004R1
PCB-U003	R4066	C-CARBON R	RN72K1J-100JE	1	435031004R1
PCB-U003	R4067	C-CARBON R	RN72K1J-101JE	1	435031014R1
PCB-U003	R4068	C-CARBON R	RN72K1J-101JE	1	435031014R1
PCB-U003	R4069	C-CARBON R	RN72K1J-221JE	1	435032214R1
PCB-U003	R4070	C-CARBON R	RN72K1J-221JE	1	435032214R1
PCB-U003	R4071	C-CARBON R	RN72K1J-331JE	1	435033314R1
PCB-U003	R4072	C-CARBON R	RN72K1J-331JE	1	435033314R1
PCB-U003	R4073	C-CARBON R	RN72K1J-563JE	1	435035634R1
PCB-U003	R4074	C-CARBON R	RN72K1J-563JE	1	435035634R1
PCB-U003	R4075	C-CARBON R	RN72K1J-224JE	1	435032244R1
PCB-U003	R4076	C-CARBON R	RN72K1J-224JE	1	435032244R1
PCB-U003	R4077	METAL O R	RS1/2WBJ-22	1	443522204T
PCB-U003	R4078	METAL O R	RS1/2WBJ-22	1	443522204T
PCB-U003	R4081	C-CARBON R	RN72K1J-331JE	1	435033314R1
PCB-U003	R4082	C-CARBON R	RN72K1J-331JE	1	435033314R1
PCB-U003	R4083	C-CARBON R	RN72K1J-563JE	1	435035634R1
PCB-U003	R4084	C-CARBON R	RN72K1J-563JE	1	435035634R1
PCB-U003	R4085	C-CARBON R	RN72K1J-224JE	1	435032244R1
PCB-U003	R4086	C-CARBON R	RN72K1J-224JE	1	435032244R1

PCB-U003	R4091	C-CARBON R	RN72K1J-331JE	1	435033314R1
PCB-U003	R4092	C-CARBON R	RN72K1J-331JE	1	435033314R1
PCB-U003	R4093	C-CARBON R	RN72K1J-563JE	1	435035634R1
PCB-U003	R4094	C-CARBON R	RN72K1J-563JE	1	435035634R1
PCB-U003	R4095	C-CARBON R	RN72K1J-224JE	1	435032244R1
PCB-U003	R4096	C-CARBON R	RN72K1J-224JE	1	435032244R1
PCB-U003	R4101	C-CARBON R	RN72K1J-331JE	1	435033314R1
PCB-U003	R4102	C-CARBON R	RN72K1J-331JE	1	435033314R1
PCB-U003	R4103	C-CARBON R	RN72K1J-563JE	1	435035634R1
PCB-U003	R4104	C-CARBON R	RN72K1J-563JE	1	435035634R1
PCB-U003	R4105	C-CARBON R	RN72K1J-224JE	1	435032244R1
PCB-U003	R4106	C-CARBON R	RN72K1J-224JE	1	435032244R1
PCB-U003	R4111	C-CARBON R	RN72K1J-331JE	1	435033314R1
PCB-U003	R4112	C-CARBON R	RN72K1J-331JE	1	435033314R1
PCB-U003	R4113	C-CARBON R	RN72K1J-224JE	1	435032244R1
PCB-U003	R4114	C-CARBON R	RN72K1J-224JE	1	435032244R1
PCB-U003	R4115	C-CARBON R	RN72K1J-100JE	1	435031004R1
PCB-U003	R4116	C-CARBON R	RN72K1J-100JE	1	435031004R1
PCB-U003	R4117	C-CARBON R	RN72K1J-101JE	1	435031014R1
PCB-U003	R4118	C-CARBON R	RN72K1J-101JE	1	435031014R1
PCB-U003	R4119	C-CARBON R	RN72K1J-221JE	1	435032214R1
PCB-U003	R4120	C-CARBON R	RN72K1J-221JE	1	435032214R1
PCB-U003	R4121	C-CARBON R	RN72K1J-331JE	1	435033314R1
PCB-U003	R4122	C-CARBON R	RN72K1J-331JE	1	435033314R1
PCB-U003	R4123	C-CARBON R	RN72K1J-563JE	1	435035634R1
PCB-U003	R4124	C-CARBON R	RN72K1J-563JE	1	435035634R1
PCB-U003	R4125	C-CARBON R	RN72K1J-224JE	1	435032244R1
PCB-U003	R4126	C-CARBON R	RN72K1J-224JE	1	435032244R1
PCB-U003	R4131	C-CARBON R	RN72K1J-331JE	1	435033314R1
PCB-U003	R4132	C-CARBON R	RN72K1J-331JE	1	435033314R1
PCB-U003	R4133	C-CARBON R	RN72K1J-563JE	1	435035634R1
PCB-U003	R4134	C-CARBON R	RN72K1J-563JE	1	435035634R1
PCB-U003	R4135	C-CARBON R	RN72K1J-224JE	1	435032244R1

PCB-U003	R4136	C-CARBON R	RN72K1J-224JE	1	435032244R1
PCB-U003	R4137	METAL O R	RS1/2WBJ-22	1	443522204T
PCB-U003	R4138	METAL O R	RS1/2WBJ-22	1	443522204T
PCB-U003	R4151	C-CARBON R	RN72K1J-224JE	1	435032244R1
PCB-U003	R4152	C-CARBON R	RN72K1J-224JE	1	435032244R1
PCB-U003	R4153	C-CARBON R	RN72K1J-224JE	1	435032244R1
PCB-U003	R4154	C-CARBON R	RN72K1J-224JE	1	435032244R1
PCB-U003	R4155	C-CARBON R	RN72K1J-224JE	1	435032244R1
PCB-U003	R4156	C-CARBON R	RN72K1J-224JE	1	435032244R1
PCB-U003	R4157	C-CARBON R	RN72K1J-224JE	1	435032244R1
PCB-U003	R4158	C-CARBON R	RN72K1J-224JE	1	435032244R1
PCB-U003	R4200	C-CARBON R	RN72K1J-102JE	1	435031024R1
PCB-U003	R4201	C-CARBON R	RN72K1J-102JE	1	435031024R1
PCB-U003	R4202	C-CARBON R	RN72K1J-102JE	1	435031024R1
PCB-U003	R4203	C-CARBON R	RN72K1J-103JE	1	435031034R1
PCB-U003	R4204	C-CARBON R	RN72K1J-100JE	1	435031004R1
PCB-U003	R4206	C-CARBON R	RN72K1J-100JE	1	435031004R1
PCB-U003	R4207	C-CARBON R	RN72K1J-102JE	1	435031024R1
PCB-U003	R4208	C-CARBON R	RN72K1J-102JE	1	435031024R1
PCB-U003	R4209	C-CARBON R	RN72K1J-102JE	1	435031024R1
PCB-U003	R4211	C-CARBON R	RN72K1J-100JE	1	435031004R1
PCB-U003	R4212	C-CARBON R	RN72K1J-103JE	1	435031034R1
PCB-U003	R4213	C-CARBON R	RN72K1J-100JE	1	435031004R1
PCB-U003	R4214	METAL O R	RS1/2WBJ-15	1	443521504T
PCB-U003	R4215	METAL O R	RS1/2WBJ-15	1	443521504T
PCB-U003	R4216	C-CARBON R	RN72K1J-681JE	1	435036814R1
PCB-U003	R4217	C-CARBON R	RN72K1J-681JE	1	435036814R1
PCB-U003	R4218	METAL O R	RS1/2WBJ-10	1	443521004T
PCB-U003	R4219	METAL O R	RS1/2WBJ-10	1	443521004T
PCB-U003	R4221	C-CARBON R	RN72K1J-224JE	1	435032244R1
PCB-U003	R4222	C-CARBON R	RN72K1J-224JE	1	435032244R1
PCB-U003	R4223	C-CARBON R	RN72K1J-224JE	1	435032244R1
PCB-U003	R4224	C-CARBON R	RN72K1J-224JE	1	435032244R1

PCB-U003	R4225	C-CARBON R	RN72K1J-103JE	1	435031034R1
PCB-U003	R4226	C-CARBON R	RN72K1J-103JE	1	435031034R1
PCB-U003	R4256	METAL O R	RS1/2WBJ-22	1	443522204T
PCB-U003	R4257	METAL O R	RS1/2WBJ-22	1	443522204T
PCB-U003	R4297	METAL O R	RS1/2WBJ-1K	1	443521024T
PCB-U003	R4301	C-CARBON R	RN72K1J-103JE	1	435031034R1
PCB-U003	R4302	C-CARBON R	RN72K1J-103JE	1	435031034R1
PCB-U003	R4303	C-CARBON R	RN72K1J-103JE	1	435031034R1
PCB-U003	R4304	C-CARBON R	RN72K1J-103JE	1	435031034R1
PCB-U003	R4307	C-CARBON R	RN72K1J-224JE	1	435032244R1
PCB-U003	R4308	C-CARBON R	RN72K1J-682JE	1	435036824R1
PCB-U003	R4309	C-CARBON R	RN72K1J-272JE	1	435032724R1
PCB-U003	R4310	C-CARBON R	RN72K1J-682JE	1	435036824R1
PCB-U003	R4323	C-CARBON R	RN72K1J-224JE	1	435032244R1
PCB-U003	R4324	C-CARBON R	RN72K1J-224JE	1	435032244R1
PCB-U003	R4325	C-CARBON R	RN72K1J-224JE	1	435032244R1
PCB-U003	R4326	C-CARBON R	RN72K1J-224JE	1	435032244R1
PCB-U003	R4341	C-CARBON R	RN72K1J-122JE	1	435031224R1
PCB-U003	R4342	C-CARBON R	RN72K1J-103JE	1	435031034R1
PCB-U003	R4343	C-CARBON R	RN72K1J-152JE	1	435031524R1
PCB-U003	R4344	C-CARBON R	RN72K1J-103JE	1	435031034R1
PCB-U003	R4346	C-CARBON R	RN72K1J-103JE	1	435031034R1
PCB-U003	R4347	C-CARBON R	RN72K1J-122JE	1	435031224R1
PCB-U003	R4348	C-CARBON R	RN72K1J-103JE	1	435031034R1
PCB-U003	R4349	C-CARBON R	RN72K1J-152JE	1	435031524R1
PCB-U003	R4350	C-CARBON R	RN72K1J-103JE	1	435031034R1
PCB-U003	R4351	C-CARBON R	RN72K1J-103JE	1	435031034R1
PCB-U003	R4352	C-CARBON R	RN72K1J-103JE	1	435031034R1
PCB-U003	R4353	C-CARBON R	RN72K1J-103JE	1	435031034R1
PCB-U003	R4354	C-CARBON R	RN72K1J-103JE	1	435031034R1
PCB-U003	R4355	C-CARBON R	RN72K1J-103JE	1	435031034R1
PCB-U003	R4357	C-CARBON R	RN72K1J-103JE	1	435031034R1
PCB-U003	R4359	C-CARBON R	RN72K1J-103JE	1	435031034R1

PCB-U003	R4360	C-CARBON R	RN72K1J-224JE	1	435032244R1
PCB-U003	R4361	C-CARBON R	RN72K1J-224JE	1	435032244R1
PCB-U003	R4371	C-CARBON R	RN72K1J-103JE	1	435031034R1
PCB-U003	R4372	C-CARBON R	RN72K1J-103JE	1	435031034R1
PCB-U003	R4373	C-CARBON R	RN72K1J-103JE	1	435031034R1
PCB-U003	R4374	C-CARBON R	RN72K1J-103JE	1	435031034R1
PCB-U003	R4375	C-CARBON R	RN72K1J-224JE	1	435032244R1
PCB-U003	R4376	C-CARBON R	RN72K1J-224JE	1	435032244R1
PCB-U003	R4381	C-CARBON R	RN72K1J-123JE	1	435031234R1
PCB-U003	R4382	C-CARBON R	RN72K1J-123JE	1	435031234R1
PCB-U003	R4383	C-CARBON R	RN72K1J-562JE	1	435035624R1
PCB-U003	R4385	C-CARBON R	RN72K1J-224JE	1	435032244R1
PCB-U003	R4386	C-CARBON R	RN72K1J-103JE	1	435031034R1
PCB-U003	R4387	C-CARBON R	RN72K1J-103JE	1	435031034R1
PCB-U003	R4391	METAL O R	RS1/2WBJ-22	1	443522204T
PCB-U003	R4392	METAL O R	RS1/2WBJ-22	1	443522204T
PCB-U003	R4393	C-CARBON R	RN72K1J-103JE	1	435031034R1
PCB-U003	R4394	C-CARBON R	RN72K1J-103JE	1	435031034R1
PCB-U003	R4395	C-CARBON R	RN72K1J-103JE	1	435031034R1
PCB-U003	R4396	C-CARBON R	RN72K1J-103JE	1	435031034R1
PCB-U003	R4397	C-CARBON R	RN72K1J-103JE	1	435031034R1
PCB-U003	R4398	C-CARBON R	RN72K1J-103JE	1	435031034R1
PCB-U003	R4399	C-CARBON R	RN72K1J-103JE	1	435031034R1
PCB-U003	R4400	C-CARBON R	RN72K1J-103JE	1	435031034R1
PCB-U003	R4401	C-CARBON R	RN72K1J-103JE	1	435031034R1
PCB-U003	R4402	METAL O R	RS1/2WBJ-22	1	443522204T
PCB-U003	R4403	METAL O R	RS1/2WBJ-22	1	443522204T
PCB-U003	R4404	C-CARBON R	RN72K1J-222JE	1	435032224R1
PCB-U003	R4405	C-CARBON R	RN72K1J-222JE	1	435032224R1
PCB-U003	R4406	C-CARBON R	RN72K1J-331JE	1	435033314R1
PCB-U003	R4407	C-CARBON R	RN72K1J-331JE	1	435033314R1
PCB-U003	R4409	C-CARBON R	RN72K1J-222JE	1	435032224R1
PCB-U003	R4410	C-CARBON R	RN72K1J-331JE	1	435033314R1

PCB-U003	R4411	C-CARBON R	RN72K1J-331JE	1	435033314R1
PCB-U003	R4412	C-CARBON R	RN72K1J-331JE	1	435033314R1
PCB-U003	R4413	C-CARBON R	RN72K1J-222JE	1	435032224R1
PCB-U003	R4414	C-CARBON R	RN72K1J-331JE	1	435033314R1
PCB-U003	R4415	C-CARBON R	RN72K1J-331JE	1	435033314R1
PCB-U003	R4416	C-CARBON R	RN72K1J-331JE	1	435033314R1
PCB-U003	R4417	C-CARBON R	RN72K1J-222JE	1	435032224R1
PCB-U003	R4418	C-CARBON R	RN72K1J-222JE	1	435032224R1
PCB-U003	R4441	C-CARBON R	RN72K1J-473JE	1	435034734R1
PCB-U003	R4442	C-CARBON R	RN72K1J-473JE	1	435034734R1
PCB-U003	R4443	C-CARBON R	RN72K1J-392JE	1	435033924R1
PCB-U003	R4444	C-CARBON R	RN72K1J-392JE	1	435033924R1
PCB-U003	R4445	C-CARBON R	RN72K1J-682JE	1	435036824R1
PCB-U003	R4446	C-CARBON R	RN72K1J-393JE	1	435033934R1
PCB-U003	R4447	C-CARBON R	RN72K1J-682JE	1	435036824R1
PCB-U003	R4448	C-CARBON R	RN72K1J-393JE	1	435033934R1
PCB-U003	R4449	C-CARBON R	RN72K1J-272JE	1	435032724R1
PCB-U003	R4450	C-CARBON R	RN72K1J-272JE	1	435032724R1
PCB-U003	R4451	C-CARBON R	RN72K1J-272JE	1	435032724R1
PCB-U003	R4452	C-CARBON R	RN72K1J-272JE	1	435032724R1
PCB-U003	R4453	C-CARBON R	RN72K2E-220JE	1	435222204R1
PCB-U003	R4454	C-CARBON R	RN72K2E-220JE	1	435222204R1
PCB-U003	R4455	C-CARBON R	RN72K2E-220JE	1	435222204R1
PCB-U003	R4456	C-CARBON R	RN72K2E-220JE	1	435222204R1
PCB-U003	R4463	C-CARBON R	RN72K1J-473JE	1	435034734R1
PCB-U003	R4464	C-CARBON R	RN72K1J-473JE	1	435034734R1
PCB-U003	R4465	C-CARBON R	RN72K1J-223JE	1	435032234R1
PCB-U003	R4466	C-CARBON R	RN72K1J-223JE	1	435032234R1
PCB-U003	R4467	C-CARBON R	RN72K1J-333JE	1	435033334R1
PCB-U003	R4468	C-CARBON R	RN72K1J-333JE	1	435033334R1
PCB-U003	R4477	C-CARBON R	RN72K1J-224JE	1	435032244R1
PCB-U003	R4478	C-CARBON R	RN72K1J-224JE	1	435032244R1
PCB-U003	R4479	METAL O R	RS1/2WBJ-47	1	443524704T

PCB-U003	R4480	METAL O R	RS1/2WBJ-47	1	443524704T
PCB-U003	R4481	C-CARBON R	RN72K1J-010JE	1	435030104R1
PCB-U003	R4482	C-CARBON R	RN72K1J-182JE	1	435031824R1
PCB-U003	R4483	C-CARBON R	RN72K1J-104JE	1	435031044R1
PCB-U003	R4484	C-CARBON R	RN72K1J-103JE	1	435031034R1
PCB-U003	R4485	C-CARBON R	RN72K1J-103JE	1	435031034R1
PCB-U003	R4550	C-CARBON R	RN72K1J-104JE	1	435031044R1
PCB-U003	R4551	C-CARBON R	RN72K1J-104JE	1	435031044R1
PCB-U003	R4552	C-CARBON R	RN72K1J-104JE	1	435031044R1
PCB-U003	R4553	C-CARBON R	RN72K1J-104JE	1	435031044R1
PCB-U003	R4554	C-CARBON R	RN72K1J-104JE	1	435031044R1
PCB-U003	R4555	C-CARBON R	RN72K1J-104JE	1	435031044R1
PCB-U003	R4556	C-CARBON R	RN72K1J-104JE	1	435031044R1
PCB-U003	R4557	C-CARBON R	RN72K1J-104JE	1	435031044R1
PCB-U003	R4558	C-CARBON R	RN72K1J-104JE	1	435031044R1
PCB-U003	R4559	C-CARBON R	RN72K1J-104JE	1	435031044R1
PCB-U003	R4560	C-CARBON R	RN72K1J-104JE	1	435031044R1
PCB-U003	R4561	C-CARBON R	RN72K1J-224JE	1	435032244R1
PCB-U003	R4562	C-CARBON R	RN72K1J-224JE	1	435032244R1
PCB-U003	R4563	C-CARBON R	RN72K1J-222JE	1	435032224R1
PCB-U003	R4600	C-CARBON R	RN72K1J-331JE	1	435033314R1
PCB-U003	R4601	C-CARBON R	RN72K1J-331JE	1	435033314R1
PCB-U003	R4602	C-CARBON R	RN72K1J-331JE	1	435033314R1
PCB-U003	R4603	C-CARBON R	RN72K1J-331JE	1	435033314R1
PCB-U003	R4604	C-CARBON R	RN72K1J-331JE	1	435033314R1
PCB-U003	R4605	C-CARBON R	RN72K1J-331JE	1	435033314R1
PCB-U003	R4606	C-CARBON R	RN72K1J-331JE	1	435033314R1
PCB-U003	R4607	C-CARBON R	RN72K1J-331JE	1	435033314R1
PCB-U003	R4610	C-CARBON R	RN72K1J-563JE	1	435035634R1
PCB-U003	R4611	C-CARBON R	RN72K1J-563JE	1	435035634R1
PCB-U003	R4612	C-CARBON R	RN72K1J-563JE	1	435035634R1
PCB-U003	R4613	C-CARBON R	RN72K1J-563JE	1	435035634R1
PCB-U003	R4614	C-CARBON R	RN72K1J-563JE	1	435035634R1



PCB-U003	R4615	C-CARBON R	RN72K1J-563JE	1	435035634R1
PCB-U003	R4616	C-CARBON R	RN72K1J-563JE	1	435035634R1
PCB-U003	R4617	C-CARBON R	RN72K1J-563JE	1	435035634R1
PCB-U003	R4620	C-CARBON R	RN72K1J-224JE	1	435032244R1
PCB-U003	R4621	C-CARBON R	RN72K1J-224JE	1	435032244R1
PCB-U003	R4622	C-CARBON R	RN72K1J-224JE	1	435032244R1
PCB-U003	R4623	C-CARBON R	RN72K1J-224JE	1	435032244R1
PCB-U003	R4624	C-CARBON R	RN72K1J-224JE	1	435032244R1
PCB-U003	R4625	C-CARBON R	RN72K1J-224JE	1	435032244R1
PCB-U003	R4626	C-CARBON R	RN72K1J-224JE	1	435032244R1
PCB-U003	R4627	C-CARBON R	RN72K1J-224JE	1	435032244R1
PCB-U003	R4630	C-CARBON R	RN72K1J-224JE	1	435032244R1
PCB-U003	R4633	C-CARBON R	RN72K1J-224JE	1	435032244R1
PCB-U003	R4634	C-CARBON R	RN72K1J-224JE	1	435032244R1
PCB-U003	R4635	C-CARBON R	RN72K1J-224JE	1	435032244R1
PCB-U003	R4636	C-CARBON R	RN72K1J-224JE	1	435032244R1
PCB-U003	R4637	C-CARBON R	RN72K1J-224JE	1	435032244R1
PCB-U003	R4640	C-CARBON R	RN72K1J-224JE	1	435032244R1
PCB-U003	R4641	C-CARBON R	RN72K1J-224JE	1	435032244R1
PCB-U003	R4642	C-CARBON R	RN72K1J-224JE	1	435032244R1
PCB-U003	R4643	C-CARBON R	RN72K1J-224JE	1	435032244R1
PCB-U003	R4644	C-CARBON R	RN72K1J-224JE	1	435032244R1
PCB-U003	R4645	C-CARBON R	RN72K1J-224JE	1	435032244R1
PCB-U003	R4646	C-CARBON R	RN72K1J-224JE	1	435032244R1
PCB-U003	R4647	C-CARBON R	RN72K1J-223JE	1	435032234R1
PCB-U003	R4648	C-CARBON R	RN72K1J-223JE	1	435032234R1
PCB-U003	R4650	C-CARBON R	RN72K1J-221JE	1	435032214R1
PCB-U003	R4651	C-CARBON R	RN72K1J-221JE	1	435032214R1
PCB-U003	R4652	C-CARBON R	RN72K1J-221JE	1	435032214R1
PCB-U003	R4653	C-CARBON R	RN72K1J-221JE	1	435032214R1
PCB-U003	R4654	C-CARBON R	RN72K1J-221JE	1	435032214R1
PCB-U003	R4655	C-CARBON R	RN72K1J-221JE	1	435032214R1
PCB-U003	R4656	C-CARBON R	RN72K1J-221JE	1	435032214R1

PCB-U003	R4657	C-CARBON R	RN72K1J-221JE	1	435032214R1
PCB-U003	R4658	C-CARBON R	RN72K1J-221JE	1	435032214R1
PCB-U003	R4660	C-CARBON R	RN72K1J-103JE	1	435031034R1
PCB-U003	R4661	C-CARBON R	RN72K1J-103JE	1	435031034R1
PCB-U003	R4662	C-CARBON R	RN72K1J-103JE	1	435031034R1
PCB-U003	R4663	C-CARBON R	RN72K1J-103JE	1	435031034R1
PCB-U003	R4664	C-CARBON R	RN72K1J-103JE	1	435031034R1
PCB-U003	R4665	C-CARBON R	RN72K1J-103JE	1	435031034R1
PCB-U003	R4666	C-CARBON R	RN72K1J-103JE	1	435031034R1
PCB-U003	R4667	C-CARBON R	RN72K1J-103JE	1	435031034R1
PCB-U003	R4668	C-CARBON R	RN72K1J-103JE	1	435031034R1
PCB-U003	R4670	C-CARBON R	RN72K1J-224JE	1	435032244R1
PCB-U003	R4671	C-CARBON R	RN72K1J-224JE	1	435032244R1
PCB-U003	R4672	C-CARBON R	RN72K1J-224JE	1	435032244R1
PCB-U003	R4673	C-CARBON R	RN72K1J-224JE	1	435032244R1
PCB-U003	R4674	C-CARBON R	RN72K1J-224JE	1	435032244R1
PCB-U003	R4675	C-CARBON R	RN72K1J-224JE	1	435032244R1
PCB-U003	R4676	C-CARBON R	RN72K1J-224JE	1	435032244R1
PCB-U003	R4677	C-CARBON R	RN72K1J-224JE	1	435032244R1
PCB-U003	R4678	C-CARBON R	RN72K1J-224JE	1	435032244R1
PCB-U003	R4680	C-CARBON R	RN72K1J-470JE	1	435034704R1
PCB-U003	R4681	C-CARBON R	RN72K1J-470JE	1	435034704R1
PCB-U003	R4682	C-CARBON R	RN72K1J-470JE	1	435034704R1
PCB-U003	R4683	C-CARBON R	RN72K1J-470JE	1	435034704R1
PCB-U003	R4684	C-CARBON R	RN72K1J-470JE	1	435034704R1
PCB-U003	R4685	C-CARBON R	RN72K1J-470JE	1	435034704R1
PCB-U003	R4686	C-CARBON R	RN72K1J-470JE	1	435034704R1
PCB-U003	R4687	C-CARBON R	RN72K1J-470JE	1	435034704R1
PCB-U003	R4688	C-CARBON R	RN72K1J-470JE	1	435034704R1
PCB-U003	R4741	C-CARBON R	RN72K1J-224JE	1	435032244R1
PCB-U003	R4742	C-CARBON R	RN72K1J-224JE	1	435032244R1
PCB-U003	R4751	C-CARBON R	RN72K1J-221JE	1	435032214R1
PCB-U003	R4752	C-CARBON R	RN72K1J-221JE	1	435032214R1

PCB-U003	R4761	C-CARBON R	RN72K1J-103JE	1	435031034R1	
PCB-U003	R4762	C-CARBON R	RN72K1J-103JE	1	435031034R1	
PCB-U003	R4771	C-CARBON R	RN72K1J-224JE	1	435032244R1	
PCB-U003	R4772	C-CARBON R	RN72K1J-224JE	1	435032244R1	
PCB-U003	R4781	C-CARBON R	RN72K1J-470JE	1	435034704R1	
PCB-U003	R4782	C-CARBON R	RN72K1J-470JE	1	435034704R1	
PCB-U003	R4801	C-CARBON R	RN72K1J-224JE	1	435032244R1	
PCB-U003	R4802	C-CARBON R	RN72K1J-224JE	1	435032244R1	
PCB-U003	R4803	C-CARBON R	RN72K1J-224JE	1	435032244R1	
PCB-U003	R4804	C-CARBON R	RN72K1J-224JE	1	435032244R1	
PCB-U003	R4811	C-CARBON R	RN72K1J-221JE	1	435032214R1	
PCB-U003	R4812	C-CARBON R	RN72K1J-221JE	1	435032214R1	
PCB-U003	R4813	C-CARBON R	RN72K1J-221JE	1	435032214R1	
PCB-U003	R4814	C-CARBON R	RN72K1J-221JE	1	435032214R1	
PCB-U003	R4821	C-CARBON R	RN72K1J-224JE	1	435032244R1	
PCB-U003	R4822	C-CARBON R	RN72K1J-224JE	1	435032244R1	
PCB-U003	R4823	C-CARBON R	RN72K1J-224JE	1	435032244R1	
PCB-U003	R4824	C-CARBON R	RN72K1J-224JE	1	435032244R1	
PCB-U003	R4831	C-CARBON R	RN72K1J-470JE	1	435034704R1	
PCB-U003	R4832	C-CARBON R	RN72K1J-470JE	1	435034704R1	
PCB-U003	R4833	C-CARBON R	RN72K1J-470JE	1	435034704R1	
PCB-U003	R4834	C-CARBON R	RN72K1J-470JE	1	435034704R1	
PCB-U003	R4841	C-CARBON R	RN72K1J-224JE	1	435032244R1	
PCB-U003	R4842	C-CARBON R	RN72K1J-224JE	1	435032244R1	
PCB-U003	<a href="#">[SW TRM]</a>					
PCB-U003	E1B	TRM	NTM-1P232(M1700)	1	25060301	
PCB-U003	E2000	TRM-423(SCREW)	NEJITANSI ST3	1	25060495	
PCB-U003	F2001A	FUSE HOL	NSCT-1P2031	1	25052133T	!
PCB-U003	F2001B	FUSE HOL	NSCT-1P2031	1	25052133T	!
PCB-U003	F2004A	FUSE HOL	NSCT-1P2031	1	25052133T	!
PCB-U003	F2004B	FUSE HOL	NSCT-1P2031	1	25052133T	!
PCB-U003	F2005A	FUSE HOL	NSCT-1P2031	1	25052133T	!
PCB-U003	F2005B	FUSE HOL	NSCT-1P2031	1	25052133T	!

PCB-U003	JL2104A	WIRE HOL	NSCT-11P882	1	25051095	
PCB-U003	JL2104B	WIRE TRAP	NPLG-11P594	1	25055632	
PCB-U003	JL2601B	WIRE TRAP	NPLG-5P588	1	25055626	
PCB-U003	JL3201A	WIRE HOL	NSCT-5P876	1	25051089	
PCB-U003	JL4014B	SOCKET	NSCT-7P99	1	25050271	
PCB-U003	JL4103A	SOCKET	NSCT-5P97	1	25050269	
PCB-U003	JL8002A	WIRE HOL	NSCT-5P896	1	25051109	
PCB-U003	JL901B	WIRE TRAP	NPLG-7P590	1	25055628	
PCB-U003	P003	PWB	BCASP-0202	1	25140202C	N
PCB-U003	P004	PWB	BCVD-0203	{ 1 }	25140203	N
PCB-U003	P103B	SOCKET	NSCT-11P2191	1	25052294	
PCB-U003	P104B	SOCKET	NSCT-7P2187	1	25052290	
PCB-U003	P105B	SOCKET	NSCT-7P2187	1	25052290	
PCB-U003	P107B	SOCKET	NSCT-11P2191	1	25052294	
PCB-U003	P2000	PLUG	NPLG-5P119	1	25055135	
PCB-U003	P2103A	PLUG	IMSA-9142B-18A	1	25056599	N
PCB-U003	P2104A	PLUG	IMSA-9142B-20A	1	25056600	
PCB-U003	P2106	PIN JACK	NPJ-6PDGLRGLR646	1	25045871	
PCB-U003	P2107	PIN JACK	NPJ-6PDGLRGLR646	1	25045871	
PCB-U003	P2110	PIN JACK	NPJ-10PDBY621	1	25045842	
PCB-U003	P2110 or	PIN JACK	NPJ-10PDBY478	( 1 )	25045681	
PCB-U003	P2111	PIN JACK	NPJ-10PDBY621	1	25045842	
PCB-U003	P2111 or	PIN JACK	NPJ-10PDBY478	( 1 )	25045681	
PCB-U003	P2112	PIN JACK	NPJ-10PDBY621	1	25045842	
PCB-U003	P2112 or	PIN JACK	NPJ-10PDBY478	( 1 )	25045681	
PCB-U003	P2113	PIN JACK	NPJ-1PDY658	1	25045886	
PCB-U003	P2500	SOCKET	NNA1-01-006	1	25053357	
PCB-U003	P2700	ST JACK	HSJ1002-01-6020	1	25045647	
PCB-U003	P2702	ST JACK	HSJ1002-01-6020	1	25045647	
PCB-U003	P2901	RETAINER	(PC-HOLD)	1	27142149	N
PCB-U003	P4001	PIN JACK	NPJ-2PDWR705	1	25045939A	N
PCB-U003	P4002A	PLUG	NPLG-9P661	1	25055705	
PCB-U003	P4004	PIN JACK	NPJ-2PDWR705	1	25045939A	N

PCB-U003	P4006	PIN JACK	NPJ-6PDWWRRR561	1	25045779	
PCB-U003	P4007	PIN JACK	NPJ-4PDWWRR624	1	25045845	
PCB-U003	P4008A	SOCKET	NSCT-9P2102	1	25052205	N
PCB-U003	P4009A	SOCKET	NSCT-15P2108	1	25052211	
PCB-U003	P4010	PIN JACK	NPJ-6PDWWRRR561	1	25045779	
PCB-U003	P4011	PIN JACK	NPJ-6PDGWRPLE695	1	25045929	
PCB-U003	P4012	PIN JACK	NPJ-2PDNT703	1	25045937	N
PCB-U003	P4017	PIN JACK	NPJ-9PDGWRPLENT697	1	25045931	N
PCB-U003	P4018	PIN JACK	NPJ-2PDWR558	1	25045776	
PCB-U003	P4022	PIN JACK	NPJ-4PDWWRR624	1	25045845	
PCB-U003	P4100	RETAINER	(JOINT)	1	27142069	
PCB-U003	P4104B	SOCKET	NSCT-31P2124	1	25052227	
PCB-U003	P5000B	PLUG	NPLG-10P357	1	25055374	
PCB-U003	P5001B	PLUG	NPLG-8P355	1	25055372	
PCB-U003	P5002B	CRIMP AS	CRIMP SR805_2	1	20799170UL	
PCB-U003	P7009A	PLUG	IMSA-9142B-18A	1	25056599	N
PCB-U003	P7010A	PLUG	IMSA-9142B-26A	1	25056603	
PCB-U003	RL4001	RELAY	NRL-2P2A-DC12-178	1	25065664	
PCB-U003	RL4002	RELAY	NRL-2P2A-DC12-178	1	25065664	
PCB-U003	RL4003	RELAY	NRL-2P2A-DC12-178	1	25065664	
PCB-U003	RL4004	RELAY	NRL-2P2A-DC12-178	1	25065664	
PCB-U003	RL4005	RELAY	NRL-2P2A-DC12-178	1	25065664	
PCB-U003	RL4006	RELAY	NRL-2P2A-DC12-178	1	25065664	
PCB-U003	RL4008	RELAY	NRL-2P2A-DC12-178	1	25065664	
PCB-U003	RL4009	RELAY	NRL-2P2A-DC12-178	1	25065664	
PCB-U003	<b>[CHASSIS SCREW]</b>					
PCB-U003	Q2000A	HEAT-SINK	HEAT-SINK(RAD-67)	1	27160209	
PCB-U003	Q2000B	SCREW	3P+6FN(3BC)	2	82143006GR	
PCB-U004	<b>U0040</b>	DAC PC BOARD (BADG-0208-1A/ 1B)				
PCB-U004	<b>U0041</b>	MAIN CPU PC BOARD (BACPU-0209-1A/ 1B)				
PCB-U004	<b>U0042</b>	ZONE-2 & ZONE-3 PC BOARD (BAAR-0210-1A/ 1B)				
PCB-U004	<b>U0043</b>	PHONO AMP. PC BOARD (BAAF-0211-1A/ 1B)				

PCB-U004 **U0044** BUFFER AMP. PC BOARD (BAACC-0212-1A/ 1B)  
 PCB-U004 **U0045** SIRIUS PC BOARD (BARF-0204-1A/ 1B)  
 PCB-U004 **U0046** DG AUDIO IN PC BOARD (BAETC-0246-1A/ 1B)

PCB-U004  
 PCB-U004

CIRCUIT.	PART NAME	DESCRIPTION	Q'TY	PART NO. (SN)	REMARKS
PCB-U004	<b>[TUNER UNIT]</b>				
PCB-U004	U3884 PHT CP	JSR1165-001recieving	1	24120143	
PCB-U004	U3885 PHT CP	JSR1165-001recieving	1	24120143	
PCB-U004	<b>[SEMI CONDUCTOR]</b>				
PCB-U004	D4001 ZENER D	UDZS5.6B	1	224550560R2	
PCB-U004	D4001 or ZENER D	MAZ8056-M	( 1)	224750562R2	
PCB-U004	D4002 ZENER D	UDZS5.6B	1	224550560R2	
PCB-U004	D4002 or ZENER D	MAZ8056-M	( 1)	224750562R2	
PCB-U004	D4003 ZENER D	UDZS3.6B	1	224550360R2	<MDC>
PCB-U004	D4003 ZENER D	UDZS3.6B	1	224550360R2	<MMP, MMO>
PCB-U004	D4004 ZENER D	UDZS3.6B	1	224550360R2	
PCB-U004	D7002 C-DIODE	1SS352	1	223234R2	
PCB-U004	D7002 or C-DIODE	1SS355	( 1)	223269R2	
PCB-U004	D7002 or C-DIODE	MA2J111	( 1)	223279R2	
PCB-U004	D7002 or C-DIODE	KDS4148U	( 1)	223283R2	
PCB-U004	D7003 C-DIODE	1SS352	1	223234R2	
PCB-U004	D7003 or C-DIODE	1SS355	( 1)	223269R2	
PCB-U004	D7003 or C-DIODE	MA2J111	( 1)	223279R2	
PCB-U004	D7003 or C-DIODE	KDS4148U	( 1)	223283R2	
PCB-U004	D7006 C-DIODE	1SS352	1	223234R2	
PCB-U004	D7006 or C-DIODE	1SS355	( 1)	223269R2	
PCB-U004	D7006 or C-DIODE	MA2J111	( 1)	223279R2	
PCB-U004	D7006 or C-DIODE	KDS4148U	( 1)	223283R2	
PCB-U004	D7007 C-DIODE	1SS352	1	223234R2	
PCB-U004	D7007 or C-DIODE	1SS355	( 1)	223269R2	
PCB-U004	D7007 or C-DIODE	MA2J111	( 1)	223279R2	
PCB-U004	D7007 or C-DIODE	KDS4148U	( 1)	223283R2	

PCB-U004	D7008	C-DIODE	1SS352	1	223234R2	
PCB-U004	D7008 or	C-DIODE	1SS355	(1)	223269R2	
PCB-U004	D7008 or	C-DIODE	MA2J111	(1)	223279R2	
PCB-U004	D7008 or	C-DIODE	KDS4148U	(1)	223283R2	
PCB-U004	D7009	C-DIODE	1SS352	1	223234R2	
PCB-U004	D7009 or	C-DIODE	1SS355	(1)	223269R2	
PCB-U004	D7009 or	C-DIODE	MA2J111	(1)	223279R2	
PCB-U004	D7009 or	C-DIODE	KDS4148U	(1)	223283R2	
PCB-U004	D7010	C-DIODE	1SS352	1	223234R2	
PCB-U004	D7010 or	C-DIODE	1SS355	(1)	223269R2	
PCB-U004	D7010 or	C-DIODE	MA2J111	(1)	223279R2	
PCB-U004	D7010 or	C-DIODE	KDS4148U	(1)	223283R2	
PCB-U004	D7011	C-DIODE	1SS352	1	223234R2	
PCB-U004	D7011 or	C-DIODE	1SS355	(1)	223269R2	
PCB-U004	D7011 or	C-DIODE	MA2J111	(1)	223279R2	
PCB-U004	D7011 or	C-DIODE	KDS4148U	(1)	223283R2	
PCB-U004	Q10	IC	NE5532APSR	1	22242283R2	<MDC>
PCB-U004	Q1001	IC	PCM1796DBR	1	22242403R2	<MDC>
PCB-U004	Q1001	IC	PCM1796DBR	1	22242403R2	<MMP, MMO>
PCB-U004	Q1002	IC	PCM1796DBR	1	22242403R2	<MDC>
PCB-U004	Q1002	IC	PCM1796DBR	1	22242403R2	<MMP, MMO>
PCB-U004	Q1003	IC	PCM1796DBR	1	22242403R2	<MDC>
PCB-U004	Q1003	IC	PCM1796DBR	1	22242403R2	<MMP, MMO>
PCB-U004	Q1004	IC	PCM1796DBR	1	22242403R2	<MDC>
PCB-U004	Q1004	IC	PCM1796DBR	1	22242403R2	<MMP, MMO>
PCB-U004	Q1005	IC	PCM1796DBR	1	22242403R2	<MDC>
PCB-U004	Q1005	IC	PCM1796DBR	1	22242403R2	<MMP, MMO>
PCB-U004	Q1006	IC	PCM1796DBR	1	22242403R2	<MDC>
PCB-U004	Q1006	IC	PCM1796DBR	1	22242403R2	<MMP, MMO>
PCB-U004	Q101	IC	LC72725KV-TLM-E	1	22242584R2	<MMP, MMO>
PCB-U004	Q1200	IC	NE5532APSR	1	22242283R2	
PCB-U004	Q1201	IC	NE5532APSR	1	22242283R2	
PCB-U004	Q1202	IC	NE5532APSR	1	22242283R2	

PCB-U004	Q1203	IC	NE5532APSR	1	22242283R2	
PCB-U004	Q1204	IC	NE5532APSR	1	22242283R2	
PCB-U004	Q1205	IC	NE5532APSR	1	22242283R2	
PCB-U004	Q1206	IC	NE5532APSR	1	22242283R2	
PCB-U004	Q1207	IC	NE5532APSR	1	22242283R2	
PCB-U004	Q1208	IC	NE5532APSR	1	22242283R2	
PCB-U004	Q1209	IC	NE5532APSR	1	22242283R2	
PCB-U004	Q1210	IC	NE5532APSR	1	22242283R2	
PCB-U004	Q1211	IC	NE5532APSR	1	22242283R2	
PCB-U004	Q1212	IC	NE5532APSR	1	22242283R2	
PCB-U004	Q1213	IC	NE5532APSR	1	22242283R2	
PCB-U004	Q1214	IC	NE5532APSR	1	22242283R2	
PCB-U004	Q1215	IC	NE5532APSR	1	22242283R2	
PCB-U004	Q1220	IC	NE5532APSR	1	22242283R2	<MDC>
PCB-U004	Q1220	IC	NE5532APSR	1	22242283R2	<MMP, MMO>
PCB-U004	Q1221	IC	NE5532APSR	1	22242283R2	<MDC>
PCB-U004	Q1221	IC	NE5532APSR	1	22242283R2	<MMP, MMO>
PCB-U004	Q1222	IC	NE5532APSR	1	22242283R2	<MDC>
PCB-U004	Q1222	IC	NE5532APSR	1	22242283R2	<MMP, MMO>
PCB-U004	Q1223	IC	NE5532APSR	1	22242283R2	<MDC>
PCB-U004	Q1223	IC	NE5532APSR	1	22242283R2	<MMP, MMO>
PCB-U004	Q1224	IC	NE5532APSR	1	22242283R2	<MDC>
PCB-U004	Q1224	IC	NE5532APSR	1	22242283R2	<MMP, MMO>
PCB-U004	Q1225	IC	NE5532APSR	1	22242283R2	<MDC>
PCB-U004	Q1225	IC	NE5532APSR	1	22242283R2	<MMP, MMO>
PCB-U004	Q1226	IC	NE5532APSR	1	22242283R2	<MDC>
PCB-U004	Q1226	IC	NE5532APSR	1	22242283R2	<MMP, MMO>
PCB-U004	Q1227	IC	NE5532APSR	1	22242283R2	<MDC>
PCB-U004	Q1227	IC	NE5532APSR	1	22242283R2	<MMP, MMO>
PCB-U004	Q1228	IC	NE5532APSR	1	22242283R2	<MDC>
PCB-U004	Q1228	IC	NE5532APSR	1	22242283R2	<MMP, MMO>
PCB-U004	Q1229	IC	NE5532APSR	1	22242283R2	<MDC>
PCB-U004	Q1229	IC	NE5532APSR	1	22242283R2	<MMP, MMO>



PCB-U004	Q1230	IC	NE5532APSR	1	22242283R2	<MDC>
PCB-U004	Q1230	IC	NE5532APSR	1	22242283R2	<MMP, MMO>
PCB-U004	Q1231	IC	NE5532APSR	1	22242283R2	<MDC>
PCB-U004	Q1231	IC	NE5532APSR	1	22242283R2	<MMP, MMO>
PCB-U004	Q1232	IC	NE5532APSR	1	22242283R2	<MDC>
PCB-U004	Q1232	IC	NE5532APSR	1	22242283R2	<MMP, MMO>
PCB-U004	Q1233	IC	NE5532APSR	1	22242283R2	<MDC>
PCB-U004	Q1233	IC	NE5532APSR	1	22242283R2	<MMP, MMO>
PCB-U004	Q1234	IC	NE5532APSR	1	22242283R2	<MDC>
PCB-U004	Q1234	IC	NE5532APSR	1	22242283R2	<MMP, MMO>
PCB-U004	Q1235	IC	NE5532APSR	1	22242283R2	<MDC>
PCB-U004	Q1235	IC	NE5532APSR	1	22242283R2	<MMP, MMO>
PCB-U004	Q1236	IC	NE5532APSR	1	22242283R2	<MDC>
PCB-U004	Q1236	IC	NE5532APSR	1	22242283R2	<MMP, MMO>
PCB-U004	Q1237	IC	NE5532APSR	1	22242283R2	<MDC>
PCB-U004	Q1237	IC	NE5532APSR	1	22242283R2	<MMP, MMO>
PCB-U004	Q1238	IC	NE5532APSR	1	22242283R2	<MDC>
PCB-U004	Q1238	IC	NE5532APSR	1	22242283R2	<MMP, MMO>
PCB-U004	Q1239	IC	NE5532APSR	1	22242283R2	<MDC>
PCB-U004	Q1239	IC	NE5532APSR	1	22242283R2	<MMP, MMO>
PCB-U004	Q1240	IC	NE5532APSR	1	22242283R2	
PCB-U004	Q1241	IC	NE5532APSR	1	22242283R2	
PCB-U004	Q1242	IC	NE5532APSR	1	22242283R2	<MDC>
PCB-U004	Q1242	IC	NE5532APSR	1	22242283R2	<MMP, MMO>
PCB-U004	Q1243	IC	NE5532APSR	1	22242283R2	<MDC>
PCB-U004	Q1243	IC	NE5532APSR	1	22242283R2	<MMP, MMO>
PCB-U004	Q1244	IC	NE5532APSR	1	22242283R2	<MDC>
PCB-U004	Q1244	IC	NE5532APSR	1	22242283R2	<MMP, MMO>
PCB-U004	Q1245	IC	NE5532APSR	1	22242283R2	<MDC>
PCB-U004	Q1245	IC	NE5532APSR	1	22242283R2	<MMP, MMO>
PCB-U004	Q1250	IC	NE5532APSR	1	22242283R2	
PCB-U004	Q1251	IC	NE5532APSR	1	22242283R2	
PCB-U004	Q1252	IC	NE5532APSR	1	22242283R2	

PCB-U004	Q1253	IC	TC9162CFG(EL)	1	22242099R2	
PCB-U004	Q1254	TR	2SC2712-GR	1	2213145R2	
PCB-U004	Q1255	TR	2SC2712-GR	1	2213145R2	
PCB-U004	Q3700	IC	CY2305SXC-1T	1	22242573R2	
PCB-U004	Q3700 or	IC	CY2305ESXC-1T	( 1)	22242638R2	
PCB-U004	Q3701	IC	TC74VHCT08AFT	1	22274008GR2TO	
PCB-U004	Q3701 or	IC	TC74VHCT08AFT (EKJ)	( 1)	22274008G1R2TO	
PCB-U004	Q3702	IC (SUB 3)	XC2C64A-7VQG100 (0341)	1	222W0095R303413	
PCB-U004	Q3703	IC	CS42516-CQZ(R)-D	1	22242294R2	
PCB-U004	Q3704	IC	TC7WU04FU(TE12L_F)	1	22240935R2	
PCB-U004	Q3705	IC	NE5532APSR	1	22242283R2	
PCB-U004	Q3706	IC	NE5532APSR	1	22242283R2	
PCB-U004	Q3885	IC	TC74VHC157FT	1	22274157ER2TO	
PCB-U004	Q3886	IC	74HCU04F	1	222740046R2	
PCB-U004	Q3886 or	IC	TC74HCU04AF	( 1)	222740046R2TO	
PCB-U004	Q3887	IC	TC74VHC157FT	1	22274157ER2TO	
PCB-U004	Q3888	IC	ICL3221ECVZ	1	22242268R2	
PCB-U004	Q3889	IC	TC74VHC157FT	1	22274157ER2TO	
PCB-U004	Q4001	IC	NE5532APSR	1	22242283R2	
PCB-U004	Q4002	TR	2SC2240-BL(TPE2_F)	1	2211406T	
PCB-U004	Q4003	TR	2SC2240-BL(TPE2_F)	1	2211406T	
PCB-U004	Q4004	TR	2SC2712-GR	1	2213145R2	
PCB-U004	Q4005	TR	2SC2712-GR	1	2213145R2	
PCB-U004	Q4006	TR	2SC2240-BL(TPE2_F)	1	2211406T	
PCB-U004	Q4007	TR	2SC2240-BL(TPE2_F)	1	2211406T	
PCB-U004	Q4037	IC	NE5532APSR	1	22242283R2	<MDC>
PCB-U004	Q4037	IC	NE5532APSR	1	22242283R2	<MMP, MMO>
PCB-U004	Q4038	IC	NE5532APSR	1	22242283R2	<MDC>
PCB-U004	Q4038	IC	NE5532APSR	1	22242283R2	<MMP, MMO>
PCB-U004	Q4046	IC	M61540FP	1	22242497R2	
PCB-U004	Q4047	IC	M61540FP	1	22242497R2	<MDC>
PCB-U004	Q4047	IC	M61540FP	1	22242497R2	<MMP, MMO>
PCB-U004	Q4500	IC	NE5532APSR	1	22242283R2	

PCB-U004	Q4501	IC	NE5532APSR	1	22242283R2
PCB-U004	Q4502	IC	NE5532APSR	1	22242283R2
PCB-U004	Q4503	IC	NE5532APSR	1	22242283R2
PCB-U004	Q4504	IC	NE5532APSR	1	22242283R2
PCB-U004	Q4505	IC	NE5532APSR	1	22242283R2
PCB-U004	Q7001	TR	KRC104S	1	2216210R2
PCB-U004	Q7001 or	TR	RN1404	( 1)	2214490R2
PCB-U004	Q7002	TR	KRA102S	1	2216220R2
PCB-U004	Q7002 or	TR	RN2402	( 1)	2214530R2
PCB-U004	Q7003	TR	KRC104S	1	2216210R2
PCB-U004	Q7003 or	TR	RN1404	( 1)	2214490R2
PCB-U004	Q7004	TR	KRA102S	1	2216220R2
PCB-U004	Q7004 or	TR	RN2402	( 1)	2214530R2
PCB-U004	Q7005	TR	KRA107S	1	2216350R2
PCB-U004	Q7005 or	TR	RN2407(TE85L_F)	( 1)	2216360R2
PCB-U004	Q7006	TR	KRC102S	1	2216190R2
PCB-U004	Q7006 or	TR	RN1402	( 1)	2214470R2
PCB-U004	Q7007	TR	KRC102S	1	2216190R2
PCB-U004	Q7007 or	TR	RN1402	( 1)	2214470R2
PCB-U004	Q7008	TR	KRA107S	1	2216350R2
PCB-U004	Q7008 or	TR	RN2407(TE85L_F)	( 1)	2216360R2
PCB-U004	Q7009	TR	KRC104S	1	2216210R2
PCB-U004	Q7009 or	TR	RN1404	( 1)	2214490R2
PCB-U004	Q7010	TR	KRA102S	1	2216220R2
PCB-U004	Q7010 or	TR	RN2402	( 1)	2214530R2
PCB-U004	Q7011	TR	KRC102S	1	2216190R2
PCB-U004	Q7011 or	TR	RN1402	( 1)	2214470R2
PCB-U004	Q7012	TR	KRC104S	1	2216210R2
PCB-U004	Q7012 or	TR	RN1404	( 1)	2214490R2
PCB-U004	Q7013	TR	KRA102S	1	2216220R2
PCB-U004	Q7013 or	TR	RN2402	( 1)	2214530R2
PCB-U004	Q7016	IC (MAIN MICROPROCESSOR)	MPD70F3746GJ-GAE-AX (0334)	1	222W0079R303340
PCB-U004	Q7017	IC	R1EX25064ASA00A	1	22242581R2

PCB-U004	Q7018	IC		NJU7706F27A3	1	22242614R2	N
PCB-U004	Q7019	IC		74HC595F	1	222745955R2	
PCB-U004	Q7020	TR		2SC2712-GR	1	2213145R2	
PCB-U004	Q7021	TR		2SC2712-GR	1	2213145R2	
PCB-U004	Q7022	IC		TC4066BFT	1	22284066MR2TO	
PCB-U004	Q7023	IC		TA4805BF(TE16L_NQ)	1	22278005DBR2TO	N
PCB-U004	Q7024	IC		S-812C33AUA-C2N	1	22242222R2	
PCB-U004	Q7025	IC		XC6202P502FR	1	22242331R2	
PCB-U004	Q7027	IC		BH33FB1WG-TR	1	22242585R2	
PCB-U004	Q7028	IC		TA4805BF(TE16L_NQ)	1	22278005DBR2TO	N
PCB-U004	Q7029	IC		TA48033BF(TE16L_NQ)	1	22278033DBR2TO	
PCB-U004	Q7030	IC		TA48018BF(TE16L_NQ)	1	22278018DBR2TO	
PCB-U004	Q7031	IC		S-812C56AUA-C3K	1	22242207R2	
PCB-U004	Q7032	TR		KRA102S	1	2216220R2	
PCB-U004	Q7032 or	TR		RN2402	(1)	2214530R2	
PCB-U004	Q7033	TR		KRC104S	1	2216210R2	
PCB-U004	Q7033 or	TR		RN1404	(1)	2214490R2	
PCB-U004	Q7034	TR		KRA102S	1	2216220R2	
PCB-U004	Q7034 or	TR		RN2402	(1)	2214530R2	
PCB-U004	Q7035	TR		KRC104S	1	2216210R2	
PCB-U004	Q7035 or	TR		RN1404	(1)	2214490R2	
PCB-U004	Q7036	IC		74HC595F	1	222745955R2	
PCB-U004	Q7037	IC		S3F80K9	1	22242602R3	<MDC>
PCB-U004	Q7037	IC		S3F80K9	1	22242602R3	<MMP, MMO>
PCB-U004	Q7038	TR		2SC2712-GR	1	2213145R2	<MDC>
PCB-U004	Q7038	TR		2SC2712-GR	1	2213145R2	<MMP, MMO>
PCB-U004	Q9	IC		NE5532APSR	1	22242283R2	<MDC>
PCB-U004	Q9	IC		NE5532APSR	1	22242283R2	<MMP, MMO>
PCB-U004	<b>[TRANS COIL]</b>						
PCB-U004	L1001	CHOKE COIL		LBC2518T4R7M	1	231364M047R2	
PCB-U004	L1002	CHOKE COIL		LBC2518T4R7M	1	231364M047R2	
PCB-U004	L1003	CHOKE COIL		LBC2518T4R7M	1	231364M047R2	
PCB-U004	L1004	CHOKE COIL		LBC2518T4R7M	1	231364M047R2	

PCB-U004	L1005	CHOKE COIL	LBC2518T4R7M	1	231364M047R2	
PCB-U004	L1006	CHOKE COIL	LBC2518T4R7M	1	231364M047R2	
PCB-U004	L1007	CHOKE COIL	LBC2518T4R7M	1	231364M047R2	
PCB-U004	L1008	CHOKE COIL	LBC2518T4R7M	1	231364M047R2	
PCB-U004	L1009	CHOKE COIL	LBC2518T4R7M	1	231364M047R2	
PCB-U004	L101	CHOKE COIL	BLM21PG221SN1	1	230949R2	<MMP, MMO>
PCB-U004	L1010	CHOKE COIL	LBC2518T4R7M	1	231364M047R2	
PCB-U004	L1011	CHOKE COIL	LBC2518T4R7M	1	231364M047R2	
PCB-U004	L1012	CHOKE COIL	LBC2518T4R7M	1	231364M047R2	
PCB-U004	L1013	CHOKE COIL	LBC2518T4R7M	1	231364M047R2	
PCB-U004	L1014	CHOKE COIL	LBC2518T4R7M	1	231364M047R2	
PCB-U004	L1015	CHOKE COIL	LBC2518T4R7M	1	231364M047R2	
PCB-U004	L1016	CHOKE COIL	LBC2518T4R7M	1	231364M047R2	
PCB-U004	L1017	CHOKE COIL	LBC2518T4R7M	1	231364M047R2	
PCB-U004	L1018	CHOKE COIL	LBC2518T4R7M	1	231364M047R2	
PCB-U004	L1019	CHOKE COIL	LBC2518T4R7M	1	231364M047R2	
PCB-U004	L1020	CHOKE COIL	LBC2518T4R7M	1	231364M047R2	
PCB-U004	L1021	CHOKE COIL	LBC2518T4R7M	1	231364M047R2	
PCB-U004	L1022	CHOKE COIL	LBC2518T4R7M	1	231364M047R2	
PCB-U004	L1023	CHOKE COIL	LBC2518T4R7M	1	231364M047R2	
PCB-U004	L1024	CHOKE COIL	LBC2518T4R7M	1	231364M047R2	
PCB-U004	L3700	CHOKE COIL	LBC2518T470M	1	231364M470R2	
PCB-U004	L3701	CHOKE COIL	LBC2518T470M	1	231364M470R2	
PCB-U004	L3702	CHOKE COIL	LBC2518T4R7M	1	231364M047R2	
PCB-U004	L3703	EMIFIL	BK1608LM182-T	1	230958R1	
PCB-U004	L3704	EMIFIL	BK1608LM182-T	1	230958R1	
PCB-U004	L3705	CHOKE COIL	LBC2518T4R7M	1	231364M047R2	
PCB-U004	L3706	CHOKE COIL	LBC2518T4R7M	1	231364M047R2	
PCB-U004	L3707	CHOKE COIL	LBC2518T470M	1	231364M470R2	
PCB-U004	L3708	CHOKE COIL	LBC2518T4R7M	1	231364M047R2	
PCB-U004	L3709	CHOKE COIL	LBC2518T4R7M	1	231364M047R2	
PCB-U004	L3710	EMIFIL	BK1608LM182-T	1	230958R1	
PCB-U004	L3711	CHOKE COIL	LBC2518T4R7M	1	231364M047R2	

PCB-U004	L3712	EMIFIL	BK1608LM182-T	1	230958R1	
PCB-U004	L3713	EMIFIL	BK1608LM182-T	1	230958R1	
PCB-U004	L3884	CHOKE COIL	LBC2518T2R2M	1	231364M022R2	
PCB-U004	L3885	CHOKE COIL	LBC2518T470M	1	231364M470R2	
PCB-U004	L3886	CHOKE COIL	LBC2518T2R2M	1	231364M022R2	
PCB-U004	L3887	CHOKE COIL	LBC2518T2R2M	1	231364M022R2	
PCB-U004	L3888	CHOKE COIL	LBC2518T470M	1	231364M470R2	
PCB-U004	L3889	CHOKE COIL	LBC2518T470M	1	231364M470R2	
PCB-U004	L3890	CHOKE COIL	LBC2518T470M	1	231364M470R2	
PCB-U004	L3892	EMIFIL	BK1608LM182-T	1	230958R1	
PCB-U004	L3893	EMIFIL	BK1608LM182-T	1	230958R1	
PCB-U004	L7001	CHOKE COIL	LBC2518T470M	1	231364M470R2	
PCB-U004	X101	CRYSTAL	HC-49S 4.332MHz	1	3010469T	<MMP, MMO>
PCB-U004	X3700	CRYSTAL	HC-49US24.576MHz	1	3010423T	
PCB-U004	X7001	CERA LOCK	CSTCR5M00G53-B0	1	3010356R2	
PCB-U004	X7301	CERA LOCK	CSTCE8M00G55-R0	1	3010416R2	<MDC>
PCB-U004	X7301	CERA LOCK	CSTCE8M00G55-R0	1	3010416R2	<MMP, MMO>
PCB-U004	<b>[CAPACITOR]</b>					
PCB-U004	C1001	C-FILM C	ECHU16V-104J	1	373041044R2	
PCB-U004	C1002	C-FILM C	ECHU16V-104J	1	373041044R2	
PCB-U004	C1003	C-FILM C	ECHU16V-104J	1	373041044R2	
PCB-U004	C1004	UTSP C	CE04W10V-220M(UTSP)	1	397532217T	
PCB-U004	C1005	C-FILM C	ECHU16V-104J	1	373041044R2	
PCB-U004	C1006	UTSP C	CE04W10V-220M(UTSP)	1	397532217T	
PCB-U004	C1007	UTSP C	CE04W10V-220M(UTSP)	1	397532217T	
PCB-U004	C1008	UTSP C	CE04W10V-220M(UTSP)	1	397532217T	
PCB-U004	C1009	UTSP C	CE04W10V-220M(UTSP)	1	397532217T	
PCB-U004	C101	C-CERA C	CC725CH1H-331J1	1	342103314R1	<MMP, MMO>
PCB-U004	C1010	UTSP C	CE04W10V-220M(UTSP)	1	397532217T	
PCB-U004	C1011	UTSJ C	CE04W25V-47M(UTSJ)	1	398054707T	
PCB-U004	C1012	UTSJ C	CE04W25V-47M(UTSJ)	1	398054707T	
PCB-U004	C1013	C-FILM C	ECHU16V-104J	1	373041044R2	
PCB-U004	C1014	C-FILM C	ECHU16V-104J	1	373041044R2	

PCB-U004	C1015	UTSP C	CE04W10V-220M(UTSP)	1	397532217T	
PCB-U004	C1016	UTSP C	CE04W10V-220M(UTSP)	1	397532217T	
PCB-U004	C1017	C-FILM C	ECHU16V-104J	1	373041044R2	
PCB-U004	C1018	C-FILM C	ECHU16V-104J	1	373041044R2	
PCB-U004	C1019	C-FILM C	ECHU16V-104J	1	373041044R2	
PCB-U004	C102	UTSP C	CE04W50V-10M(UTSP)	1	397581007T	<MMP, MMO>
PCB-U004	C1020	UTSP C	CE04W10V-220M(UTSP)	1	397532217T	
PCB-U004	C1021	C-FILM C	ECHU16V-104J	1	373041044R2	
PCB-U004	C1022	UTSP C	CE04W10V-220M(UTSP)	1	397532217T	
PCB-U004	C1023	UTSP C	CE04W10V-220M(UTSP)	1	397532217T	
PCB-U004	C1024	UTSP C	CE04W10V-220M(UTSP)	1	397532217T	
PCB-U004	C1025	UTSP C	CE04W10V-220M(UTSP)	1	397532217T	
PCB-U004	C1026	UTSP C	CE04W10V-220M(UTSP)	1	397532217T	
PCB-U004	C1027	UTSJ C	CE04W25V-47M(UTSJ)	1	398054707T	
PCB-U004	C1028	UTSJ C	CE04W25V-47M(UTSJ)	1	398054707T	
PCB-U004	C1029	C-FILM C	ECHU16V-104J	1	373041044R2	
PCB-U004	C103	UTSP C	CE04W50V-10M(UTSP)	1	397581007T	<MMP, MMO>
PCB-U004	C1030	C-FILM C	ECHU16V-104J	1	373041044R2	
PCB-U004	C1031	UTSP C	CE04W10V-220M(UTSP)	1	397532217T	
PCB-U004	C1032	UTSP C	CE04W10V-220M(UTSP)	1	397532217T	
PCB-U004	C1033	C-FILM C	ECHU16V-104J	1	373041044R2	
PCB-U004	C1034	C-FILM C	ECHU16V-104J	1	373041044R2	
PCB-U004	C1035	C-FILM C	ECHU16V-104J	1	373041044R2	
PCB-U004	C1036	UTSP C	CE04W10V-220M(UTSP)	1	397532217T	
PCB-U004	C1037	C-FILM C	ECHU16V-104J	1	373041044R2	
PCB-U004	C1038	UTSP C	CE04W10V-220M(UTSP)	1	397532217T	
PCB-U004	C1039	UTSP C	CE04W10V-220M(UTSP)	1	397532217T	
PCB-U004	C104	C-CERA C	CK725B1H-103K1	1	332101035R1	<MMP, MMO>
PCB-U004	C1040	UTSP C	CE04W10V-220M(UTSP)	1	397532217T	
PCB-U004	C1041	UTSP C	CE04W10V-220M(UTSP)	1	397532217T	
PCB-U004	C1042	UTSP C	CE04W10V-220M(UTSP)	1	397532217T	
PCB-U004	C1043	UTSJ C	CE04W25V-47M(UTSJ)	1	398054707T	
PCB-U004	C1044	UTSJ C	CE04W25V-47M(UTSJ)	1	398054707T	

PCB-U004	C1045	C-FILM C	ECHU16V-104J	1	373041044R2	
PCB-U004	C1046	C-FILM C	ECHU16V-104J	1	373041044R2	
PCB-U004	C1047	UTSP C	CE04W10V-220M(UTSP)	1	397532217T	
PCB-U004	C1048	UTSP C	CE04W10V-220M(UTSP)	1	397532217T	
PCB-U004	C105	C-CERA C	CC725CH1H-331J1	1	342103314R1	<MMP, MMO>
PCB-U004	C106	C-CERA C	CK725F1E-104Z1	1	332161040R1	<MMP, MMO>
PCB-U004	C107	C-CERA C	CC725CH1H-150J1	1	342101504R1	<MMP, MMO>
PCB-U004	C108	C-CERA C	CC725CH1H-150J1	1	342101504R1	<MMP, MMO>
PCB-U004	C109	C-CERA C	CC725CH1H-221J1	1	342102214R1	<MMP, MMO>
PCB-U004	C1200	C-FILM C	ECHU50V-152J	1	373021524R2	
PCB-U004	C1201	C-FILM C	ECHU50V-152J	1	373021524R2	
PCB-U004	C1202	C-FILM C	ECHU50V-152J	1	373021524R2	
PCB-U004	C1203	C-FILM C	ECHU50V-152J	1	373021524R2	
PCB-U004	C1204	C-FILM C	ECHU50V-152J	1	373021524R2	
PCB-U004	C1205	MKT C	B32529C0152J289	1	376491524T	
PCB-U004	C1206	MKT C	B32529C0152J289	1	376491524T	
PCB-U004	C1207	C-FILM C	ECHU50V-152J	1	373021524R2	
PCB-U004	C1208	MKT C	B32529C0152J289	1	376491524T	
PCB-U004	C1209	MKT C	B32529C0152J289	1	376491524T	
PCB-U004	C1210	C-FILM C	ECHU50V-152J	1	373021524R2	
PCB-U004	C1211	C-FILM C	ECHU50V-152J	1	373021524R2	
PCB-U004	C1212	C-FILM C	ECHU50V-152J	1	373021524R2	
PCB-U004	C1213	C-FILM C	ECHU50V-152J	1	373021524R2	
PCB-U004	C1214	C-FILM C	ECHU50V-152J	1	373021524R2	
PCB-U004	C1215	MKT C	B32529C0152J289	1	376491524T	
PCB-U004	C1216	MKT C	B32529C0152J289	1	376491524T	
PCB-U004	C1217	C-FILM C	ECHU50V-152J	1	373021524R2	
PCB-U004	C1218	MKT C	B32529C0152J289	1	376491524T	
PCB-U004	C1219	MKT C	B32529C0152J289	1	376491524T	
PCB-U004	C1220	UPZ C	2AUPZTF101JE	1	376331014T	
PCB-U004	C1221	UPZ C	2AUPZTF101JE	1	376331014T	
PCB-U004	C1222	UPZ C	2AUPZTF101JE	1	376331014T	
PCB-U004	C1223	UPZ C	2AUPZTF101JE	1	376331014T	



PCB-U004	C1224	UPZ C	2AUPZTF101JE	1	376331014T	
PCB-U004	C1225	UPZ C	2AUPZTF101JE	1	376331014T	
PCB-U004	C1226	UPZ C	2AUPZTF101JE	1	376331014T	
PCB-U004	C1227	UPZ C	2AUPZTF101JE	1	376331014T	
PCB-U004	C1228	UPZ C	2AUPZTF101JE	1	376331014T	
PCB-U004	C1229	UPZ C	2AUPZTF101JE	1	376331014T	
PCB-U004	C1230	UPZ C	2AUPZTF331JE	1	376333314T	<MDC>
PCB-U004	C1230	UPZ C	2AUPZTF331JE	1	376333314T	<MMP, MMO>
PCB-U004	C1231	UPZ C	2AUPZTF331JE	1	376333314T	<MDC>
PCB-U004	C1231	UPZ C	2AUPZTF331JE	1	376333314T	<MMP, MMO>
PCB-U004	C1232	UPZ C	2AUPZTF331JE	1	376333314T	<MDC>
PCB-U004	C1232	UPZ C	2AUPZTF331JE	1	376333314T	<MMP, MMO>
PCB-U004	C1233	UPZ C	2AUPZTF331JE	1	376333314T	<MDC>
PCB-U004	C1233	UPZ C	2AUPZTF331JE	1	376333314T	<MMP, MMO>
PCB-U004	C1234	UPZ C	2AUPZTF331JE	1	376333314T	<MDC>
PCB-U004	C1234	UPZ C	2AUPZTF331JE	1	376333314T	<MMP, MMO>
PCB-U004	C1235	UPZ C	2AUPZTF331JE	1	376333314T	<MDC>
PCB-U004	C1235	UPZ C	2AUPZTF331JE	1	376333314T	<MMP, MMO>
PCB-U004	C1236	UPZ C	2AUPZTF331JE	1	376333314T	<MDC>
PCB-U004	C1236	UPZ C	2AUPZTF331JE	1	376333314T	<MMP, MMO>
PCB-U004	C1237	UPZ C	2AUPZTF331JE	1	376333314T	<MDC>
PCB-U004	C1237	UPZ C	2AUPZTF331JE	1	376333314T	<MMP, MMO>
PCB-U004	C1238	UPZ C	2AUPZTF331JE	1	376333314T	<MDC>
PCB-U004	C1238	UPZ C	2AUPZTF331JE	1	376333314T	<MMP, MMO>
PCB-U004	C1239	UPZ C	2AUPZTF331JE	1	376333314T	<MDC>
PCB-U004	C1239	UPZ C	2AUPZTF331JE	1	376333314T	<MMP, MMO>
PCB-U004	C1240	UPZ C	2AUPZTF331JE	1	376333314T	<MDC>
PCB-U004	C1240	UPZ C	2AUPZTF331JE	1	376333314T	<MMP, MMO>
PCB-U004	C1241	UPZ C	2AUPZTF331JE	1	376333314T	<MDC>
PCB-U004	C1241	UPZ C	2AUPZTF331JE	1	376333314T	<MMP, MMO>
PCB-U004	C1242	UPZ C	2AUPZTF331JE	1	376333314T	<MDC>
PCB-U004	C1242	UPZ C	2AUPZTF331JE	1	376333314T	<MMP, MMO>
PCB-U004	C1243	UPZ C	2AUPZTF331JE	1	376333314T	<MDC>

PCB-U004	C1243	UPZ C	2AUPZTF331JE	1	376333314T	<MMP, MMO>
PCB-U004	C1244	UPZ C	2AUPZTF331JE	1	376333314T	<MDC>
PCB-U004	C1244	UPZ C	2AUPZTF331JE	1	376333314T	<MMP, MMO>
PCB-U004	C1245	UPZ C	2AUPZTF331JE	1	376333314T	<MDC>
PCB-U004	C1245	UPZ C	2AUPZTF331JE	1	376333314T	<MMP, MMO>
PCB-U004	C1246	UPZ C	2AUPZTF331JE	1	376333314T	<MDC>
PCB-U004	C1246	UPZ C	2AUPZTF331JE	1	376333314T	<MMP, MMO>
PCB-U004	C1247	UPZ C	2AUPZTF331JE	1	376333314T	<MDC>
PCB-U004	C1247	UPZ C	2AUPZTF331JE	1	376333314T	<MMP, MMO>
PCB-U004	C1248	UPZ C	2AUPZTF331JE	1	376333314T	<MDC>
PCB-U004	C1248	UPZ C	2AUPZTF331JE	1	376333314T	<MMP, MMO>
PCB-U004	C1249	UPZ C	2AUPZTF331JE	1	376333314T	<MDC>
PCB-U004	C1249	UPZ C	2AUPZTF331JE	1	376333314T	<MMP, MMO>
PCB-U004	C1250	MKT C	B32529C0682J289	1	376496824T	<MDC>
PCB-U004	C1250	MKT C	B32529C0682J289	1	376496824T	<MMP, MMO>
PCB-U004	C1251	MKT C	B32529C0682J289	1	376496824T	<MDC>
PCB-U004	C1251	MKT C	B32529C0682J289	1	376496824T	<MMP, MMO>
PCB-U004	C1252	MKT C	B32529C0682J289	1	376496824T	<MDC>
PCB-U004	C1252	MKT C	B32529C0682J289	1	376496824T	<MMP, MMO>
PCB-U004	C1253	MKT C	B32529C0682J289	1	376496824T	<MDC>
PCB-U004	C1253	MKT C	B32529C0682J289	1	376496824T	<MMP, MMO>
PCB-U004	C1254	MKT C	B32529C0682J289	1	376496824T	<MDC>
PCB-U004	C1254	MKT C	B32529C0682J289	1	376496824T	<MMP, MMO>
PCB-U004	C1255	MKT C	B32529C0682J289	1	376496824T	<MDC>
PCB-U004	C1255	MKT C	B32529C0682J289	1	376496824T	<MMP, MMO>
PCB-U004	C1256	MKT C	B32529C0682J289	1	376496824T	<MDC>
PCB-U004	C1256	MKT C	B32529C0682J289	1	376496824T	<MMP, MMO>
PCB-U004	C1257	MKT C	B32529C0682J289	1	376496824T	<MDC>
PCB-U004	C1257	MKT C	B32529C0682J289	1	376496824T	<MMP, MMO>
PCB-U004	C1258	MKT C	B32529C0682J289	1	376496824T	<MDC>
PCB-U004	C1258	MKT C	B32529C0682J289	1	376496824T	<MMP, MMO>
PCB-U004	C1259	MKT C	B32529C0682J289	1	376496824T	<MDC>
PCB-U004	C1259	MKT C	B32529C0682J289	1	376496824T	<MMP, MMO>

PCB-U004	C1260	UPZ C	2AUPZTF221JE	1	376332214T	<MDC>
PCB-U004	C1260	UPZ C	2AUPZTF221JE	1	376332214T	<MMP, MMO>
PCB-U004	C1261	UPZ C	2AUPZTF221JE	1	376332214T	<MDC>
PCB-U004	C1261	UPZ C	2AUPZTF221JE	1	376332214T	<MMP, MMO>
PCB-U004	C1262	UPZ C	2AUPZTF221JE	1	376332214T	<MDC>
PCB-U004	C1262	UPZ C	2AUPZTF221JE	1	376332214T	<MMP, MMO>
PCB-U004	C1263	UPZ C	2AUPZTF221JE	1	376332214T	<MDC>
PCB-U004	C1263	UPZ C	2AUPZTF221JE	1	376332214T	<MMP, MMO>
PCB-U004	C1264	UPZ C	2AUPZTF221JE	1	376332214T	<MDC>
PCB-U004	C1264	UPZ C	2AUPZTF221JE	1	376332214T	<MMP, MMO>
PCB-U004	C1265	UPZ C	2AUPZTF221JE	1	376332214T	<MDC>
PCB-U004	C1265	UPZ C	2AUPZTF221JE	1	376332214T	<MMP, MMO>
PCB-U004	C1266	UPZ C	2AUPZTF221JE	1	376332214T	<MDC>
PCB-U004	C1266	UPZ C	2AUPZTF221JE	1	376332214T	<MMP, MMO>
PCB-U004	C1267	UPZ C	2AUPZTF221JE	1	376332214T	<MDC>
PCB-U004	C1267	UPZ C	2AUPZTF221JE	1	376332214T	<MMP, MMO>
PCB-U004	C1268	UPZ C	2AUPZTF221JE	1	376332214T	<MDC>
PCB-U004	C1268	UPZ C	2AUPZTF221JE	1	376332214T	<MMP, MMO>
PCB-U004	C1269	UPZ C	2AUPZTF221JE	1	376332214T	<MDC>
PCB-U004	C1269	UPZ C	2AUPZTF221JE	1	376332214T	<MMP, MMO>
PCB-U004	C1270	UPZ C	2AUPZTF101JE	1	376331014T	<MDC>
PCB-U004	C1270	UPZ C	2AUPZTF101JE	1	376331014T	<MMP, MMO>
PCB-U004	C1271	UPZ C	2AUPZTF101JE	1	376331014T	<MDC>
PCB-U004	C1271	UPZ C	2AUPZTF101JE	1	376331014T	<MMP, MMO>
PCB-U004	C1272	UPZ C	2AUPZTF101JE	1	376331014T	<MDC>
PCB-U004	C1272	UPZ C	2AUPZTF101JE	1	376331014T	<MMP, MMO>
PCB-U004	C1273	UPZ C	2AUPZTF101JE	1	376331014T	<MDC>
PCB-U004	C1273	UPZ C	2AUPZTF101JE	1	376331014T	<MMP, MMO>
PCB-U004	C1274	UPZ C	2AUPZTF101JE	1	376331014T	<MDC>
PCB-U004	C1274	UPZ C	2AUPZTF101JE	1	376331014T	<MMP, MMO>
PCB-U004	C1275	UPZ C	2AUPZTF101JE	1	376331014T	<MDC>
PCB-U004	C1275	UPZ C	2AUPZTF101JE	1	376331014T	<MMP, MMO>
PCB-U004	C1276	UPZ C	2AUPZTF101JE	1	376331014T	<MDC>

PCB-U004	C1276	UPZ C	2AUPZTF101JE	1	376331014T	<MMP, MMO>
PCB-U004	C1277	UPZ C	2AUPZTF101JE	1	376331014T	<MDC>
PCB-U004	C1277	UPZ C	2AUPZTF101JE	1	376331014T	<MMP, MMO>
PCB-U004	C1278	UPZ C	2AUPZTF101JE	1	376331014T	<MDC>
PCB-U004	C1278	UPZ C	2AUPZTF101JE	1	376331014T	<MMP, MMO>
PCB-U004	C1279	UPZ C	2AUPZTF101JE	1	376331014T	<MDC>
PCB-U004	C1279	UPZ C	2AUPZTF101JE	1	376331014T	<MMP, MMO>
PCB-U004	C1280	C-FILM C	ECHU50V-222J	1	373022224R2	<MDC>
PCB-U004	C1280	C-FILM C	ECHU50V-222J	1	373022224R2	<MMP, MMO>
PCB-U004	C1281	C-FILM C	ECHU50V-222J	1	373022224R2	<MDC>
PCB-U004	C1281	C-FILM C	ECHU50V-222J	1	373022224R2	<MMP, MMO>
PCB-U004	C1282	C-FILM C	ECHU50V-222J	1	373022224R2	<MDC>
PCB-U004	C1282	C-FILM C	ECHU50V-222J	1	373022224R2	<MMP, MMO>
PCB-U004	C1283	C-FILM C	ECHU50V-222J	1	373022224R2	<MDC>
PCB-U004	C1283	C-FILM C	ECHU50V-222J	1	373022224R2	<MMP, MMO>
PCB-U004	C1284	C-FILM C	ECHU50V-222J	1	373022224R2	<MDC>
PCB-U004	C1284	C-FILM C	ECHU50V-222J	1	373022224R2	<MMP, MMO>
PCB-U004	C1285	C-FILM C	ECHU50V-222J	1	373022224R2	<MDC>
PCB-U004	C1285	C-FILM C	ECHU50V-222J	1	373022224R2	<MMP, MMO>
PCB-U004	C1286	C-FILM C	ECHU50V-222J	1	373022224R2	<MDC>
PCB-U004	C1286	C-FILM C	ECHU50V-222J	1	373022224R2	<MMP, MMO>
PCB-U004	C1287	C-FILM C	ECHU50V-222J	1	373022224R2	<MDC>
PCB-U004	C1287	C-FILM C	ECHU50V-222J	1	373022224R2	<MMP, MMO>
PCB-U004	C1288	C-FILM C	ECHU50V-222J	1	373022224R2	<MDC>
PCB-U004	C1288	C-FILM C	ECHU50V-222J	1	373022224R2	<MMP, MMO>
PCB-U004	C1289	C-FILM C	ECHU50V-222J	1	373022224R2	<MDC>
PCB-U004	C1289	C-FILM C	ECHU50V-222J	1	373022224R2	<MMP, MMO>
PCB-U004	C1290	UTSP C	CE04W25V-220M(UTSP)	1	397552217T	
PCB-U004	C1291	UTSP C	CE04W25V-220M(UTSP)	1	397552217T	
PCB-U004	C1292	UTSP C	CE04W25V-220M(UTSP)	1	397552217T	
PCB-U004	C1293	UTSP C	CE04W25V-220M(UTSP)	1	397552217T	
PCB-U004	C1294	UTSP C	CE04W25V-220M(UTSP)	1	397552217T	
PCB-U004	C1295	UTSP C	CE04W25V-220M(UTSP)	1	397552217T	

PCB-U004	C1296	UTSP C	CE04W25V-220M(UTSP)	1	397552217T	
PCB-U004	C1297	UTSP C	CE04W25V-220M(UTSP)	1	397552217T	
PCB-U004	C1298	UTSP C	CE04W25V-220M(UTSP)	1	397552217T	
PCB-U004	C1299	UTSP C	CE04W25V-220M(UTSP)	1	397552217T	
PCB-U004	C1410	MKT C	B32529C0152J289	1	376491524T	
PCB-U004	C1411	MKT C	B32529C0152J289	1	376491524T	
PCB-U004	C1420	MKT C	B32529C0152J289	1	376491524T	
PCB-U004	C1421	MKT C	B32529C0152J289	1	376491524T	
PCB-U004	C1430	UPZ C	2AUPZTF101JE	1	376331014T	
PCB-U004	C1431	UPZ C	2AUPZTF101JE	1	376331014T	
PCB-U004	C1440	UPZ C	2AUPZTF331JE	1	376333314T	<MDC>
PCB-U004	C1440	UPZ C	2AUPZTF331JE	1	376333314T	<MMP, MMO>
PCB-U004	C1441	UPZ C	2AUPZTF331JE	1	376333314T	<MDC>
PCB-U004	C1441	UPZ C	2AUPZTF331JE	1	376333314T	<MMP, MMO>
PCB-U004	C1450	UPZ C	2AUPZTF331JE	1	376333314T	<MDC>
PCB-U004	C1450	UPZ C	2AUPZTF331JE	1	376333314T	<MMP, MMO>
PCB-U004	C1451	UPZ C	2AUPZTF331JE	1	376333314T	<MDC>
PCB-U004	C1451	UPZ C	2AUPZTF331JE	1	376333314T	<MMP, MMO>
PCB-U004	C1460	MKT C	B32529C0682J289	1	376496824T	<MDC>
PCB-U004	C1460	MKT C	B32529C0682J289	1	376496824T	<MMP, MMO>
PCB-U004	C1461	MKT C	B32529C0682J289	1	376496824T	<MDC>
PCB-U004	C1461	MKT C	B32529C0682J289	1	376496824T	<MMP, MMO>
PCB-U004	C1470	UPZ C	2AUPZTF221JE	1	376332214T	<MDC>
PCB-U004	C1470	UPZ C	2AUPZTF221JE	1	376332214T	<MMP, MMO>
PCB-U004	C1471	UPZ C	2AUPZTF221JE	1	376332214T	<MDC>
PCB-U004	C1471	UPZ C	2AUPZTF221JE	1	376332214T	<MMP, MMO>
PCB-U004	C1480	UPZ C	2AUPZTF101JE	1	376331014T	<MDC>
PCB-U004	C1480	UPZ C	2AUPZTF101JE	1	376331014T	<MMP, MMO>
PCB-U004	C1481	UPZ C	2AUPZTF101JE	1	376331014T	<MDC>
PCB-U004	C1481	UPZ C	2AUPZTF101JE	1	376331014T	<MMP, MMO>
PCB-U004	C1490	C-FILM C	ECHU50V-222J	1	373022224R2	<MDC>
PCB-U004	C1490	C-FILM C	ECHU50V-222J	1	373022224R2	<MMP, MMO>
PCB-U004	C1491	C-FILM C	ECHU50V-222J	1	373022224R2	<MDC>

PCB-U004	C1491	C-FILM C	ECHU50V-222J	1	373022224R2	<MMP, MMO>
PCB-U004	C1500	UTSP C	CE04W25V-220M(UTSP)	1	397552217T	
PCB-U004	C1501	UTSP C	CE04W25V-220M(UTSP)	1	397552217T	
PCB-U004	C1510	C-CERA C	CK725B1H-472K1	1	332104725R1	
PCB-U004	C1511	C-CERA C	CK725B1H-472K1	1	332104725R1	
PCB-U004	C1512	C-CERA C	CK725B1H-472K1	1	332104725R1	
PCB-U004	C1513	C-CERA C	CK725B1H-472K1	1	332104725R1	
PCB-U004	C1514	C-CERA C	CK725B1H-472K1	1	332104725R1	
PCB-U004	C21	VR C	CE04W16V-220M(VR)	1	394642217T	<MDC>
PCB-U004	C21	VR C	CE04W16V-220M(VR)	1	394642217T	<MMP, MMO>
PCB-U004	C26	VR C	CE04W16V-220M(VR)	1	394642217T	<MDC>
PCB-U004	C26	VR C	CE04W16V-220M(VR)	1	394642217T	<MMP, MMO>
PCB-U004	C3	VR C	CE04W16V-100M(VR)	1	394641017T	<MDC>
PCB-U004	C3	VR C	CE04W16V-100M(VR)	1	394641017T	<MMP, MMO>
PCB-U004	C3703	C-CERA C	CK725F1E-104Z1	1	332161040R1	
PCB-U004	C3705	UTSJ C	CE04W25V-47M(UTSJ)	1	398054707T	
PCB-U004	C3706	C-CERA C	CK725F1E-104Z1	1	332161040R1	
PCB-U004	C3707	C-CERA C	CK725F1E-104Z1	1	332161040R1	
PCB-U004	C3709	C-CERA C	CK725F1E-104Z1	1	332161040R1	
PCB-U004	C3710	VR C	CE04W16V-100M(VR)	1	394641017T	
PCB-U004	C3711	C-CERA C	CK725F1E-104Z1	1	332161040R1	
PCB-U004	C3712	C-CERA C	CK725F1E-104Z1	1	332161040R1	
PCB-U004	C3713	C-CERA C	CK725F1E-104Z1	1	332161040R1	
PCB-U004	C3714	UTSJ C	CE04W25V-47M(UTSJ)	1	398054707T	
PCB-U004	C3715	VR C	CE04W16V-100M(VR)	1	394641017T	
PCB-U004	C3716	UTSP C	CE04W10V-470M(UTSP)	1	397534717T	
PCB-U004	C3717	C-FILM C	ECHU50V-222J	1	373022224R2	
PCB-U004	C3718	C-FILM C	ECHU50V-222J	1	373022224R2	
PCB-U004	C3719	C-CERA C	CK725F1E-104Z1	1	332161040R1	
PCB-U004	C3720	C-CERA C	CK725B1H-102K1	1	332101025R1	
PCB-U004	C3721	C-CERA C	CK725B1H-223K1	1	332102235R1	
PCB-U004	C3722	C-CERA C	CK725F1E-104Z1	1	332161040R1	
PCB-U004	C3723	C-CERA C	CK725F1E-104Z1	1	332161040R1	

PCB-U004	C3724	C-CERA C	CK725F1E-104Z1	1	332161040R1
PCB-U004	C3725	C-CERA C	CK725F1E-104Z1	1	332161040R1
PCB-U004	C3726	C-CERA C	CK725B1H-102K1	1	332101025R1
PCB-U004	C3727	UTSP C	CE04W10V-470M(UTSP)	1	397534717T
PCB-U004	C3728	UTSP C	CE04W10V-470M(UTSP)	1	397534717T
PCB-U004	C3729	UTSP C	CE04W10V-470M(UTSP)	1	397534717T
PCB-U004	C3730	C-CERA C	CK725F1E-104Z1	1	332161040R1
PCB-U004	C3731	C-CERA C	CK725F1E-104Z1	1	332161040R1
PCB-U004	C3732	C-CERA C	CK725F1E-104Z1	1	332161040R1
PCB-U004	C3733	C-CERA C	CC725CH1H-330J1	1	342103304R1
PCB-U004	C3734	C-CERA C	CK725F1E-104Z1	1	332161040R1
PCB-U004	C3735	C-CERA C	CC725CH1H-330J1	1	342103304R1
PCB-U004	C3737	UTSP C	CE04W10V-470M(UTSP)	1	397534717T
PCB-U004	C3738	UTSP C	CE04W10V-470M(UTSP)	1	397534717T
PCB-U004	C3739	C-CERA C	CK725F1E-104Z1	1	332161040R1
PCB-U004	C3740	C-CERA C	CK725F1E-104Z1	1	332161040R1
PCB-U004	C3742	C-CERA C	CC725CH1H-060D1	1	342100602R1
PCB-U004	C3743	C-CERA C	CC725CH1H-060D1	1	342100602R1
PCB-U004	C3745	UTSP C	CE04W25V-220M(UTSP)	1	397552217T
PCB-U004	C3746	UTSP C	CE04W25V-220M(UTSP)	1	397552217T
PCB-U004	C3747	UTSP C	CE04W25V-47M(UTSP)	1	397554707T
PCB-U004	C3748	UTSP C	CE04W25V-47M(UTSP)	1	397554707T
PCB-U004	C3749	UTSP C	CE04W25V-47M(UTSP)	1	397554707T
PCB-U004	C3750	UTSP C	CE04W25V-47M(UTSP)	1	397554707T
PCB-U004	C3886	C-CERA C	CK725B1C-104K1	1	332121045R1
PCB-U004	C3887	C-CERA C	CC725CH1H-101J1	1	342101014R1
PCB-U004	C3888	VR C	CE04W16V-100M(VR)	1	394641017T
PCB-U004	C3889	C-CERA C	CC725CH1H-101J1	1	342101014R1
PCB-U004	C3890	C-CERA C	CK725F1E-104Z1	1	332161040R1
PCB-U004	C3891	C-CERA C	CK725F1E-104Z1	1	332161040R1
PCB-U004	C3892	C-CERA C	CK725B1C-104K1	1	332121045R1
PCB-U004	C3893	C-CERA C	CC725CH1H-080D1	1	342100802R1
PCB-U004	C3894	C-CERA C	CK725B1C-104K1	1	332121045R1

PCB-U004	C3895	C-CERA C	CC725CH1H-080D1	1	342100802R1	
PCB-U004	C3896	C-CERA C	CC725CH1H-101J1	1	342101014R1	
PCB-U004	C3897	C-CERA C	CK725F1E-104Z1	1	332161040R1	
PCB-U004	C3898	C-CERA C	CC725CH1H-080D1	1	342100802R1	
PCB-U004	C3899	C-CERA C	CK725F1E-104Z1	1	332161040R1	
PCB-U004	C3900	C-CERA C	CK725F1E-104Z1	1	332161040R1	
PCB-U004	C3901	UTSP C	CE04W50V-1M(UTSP)	1	397580107T	
PCB-U004	C3902	C-CERA C	CK725F1E-104Z1	1	332161040R1	
PCB-U004	C3903	UTSP C	CE04W50V-1M(UTSP)	1	397580107T	
PCB-U004	C3904	VR C	CE04W16V-100M(VR)	1	394641017T	
PCB-U004	C3905	C-CERA C	CK725F1E-104Z1	1	332161040R1	
PCB-U004	C3906	UTSP C	CE04W50V-1M(UTSP)	1	397580107T	
PCB-U004	C3907	UTSP C	CE04W50V-1M(UTSP)	1	397580107T	
PCB-U004	C3908	C-CERA C	CK725F1E-104Z1	1	332161040R1	
PCB-U004	C3909	C-CERA C	CK725B1H-102K1	1	332101025R1	
PCB-U004	C3911	C-CERA C	CK725B1H-102K1	1	332101025R1	
PCB-U004	C3912	VR C	CE04W16V-100M(VR)	1	394641017T	
PCB-U004	C4	C-CERA C	CC725CH1H-101J1	1	342101014R1	<MDC>
PCB-U004	C4	C-CERA C	CC725CH1H-101J1	1	342101014R1	<MMP, MMO>
PCB-U004	C4003	UTSP C	CE04W50V 47M(UTSP)	1	397584707T	
PCB-U004	C4004	UTSP C	CE04W50V 47M(UTSP)	1	397584707T	
PCB-U004	C4005	C-CERA C	CC725CH1H-221J1	1	342102214R1	
PCB-U004	C4006	C-CERA C	CC725CH1H-221J1	1	342102214R1	
PCB-U004	C4007	UTSP C	CE04W50V 47M(UTSP)	1	397584707T	
PCB-U004	C4008	UTSP C	CE04W50V 47M(UTSP)	1	397584707T	
PCB-U004	C4009	C-CERA C	CC725CH1H-152J1	1	342101524R1	
PCB-U004	C4010	C-CERA C	CC725CH1H-152J1	1	342101524R1	
PCB-U004	C4011	UTSP C	CE04W25V-220M(UTSP)	1	397552217T	
PCB-U004	C4012	UTSP C	CE04W25V-220M(UTSP)	1	397552217T	
PCB-U004	C4013	MKT C	B32529C0682J289	1	376496824T	
PCB-U004	C4014	C-FILM C	ECHU50V-182J	1	373021824R2	
PCB-U004	C4015	MKT C	B32529C0682J289	1	376496824T	
PCB-U004	C4016	C-FILM C	ECHU50V-182J	1	373021824R2	



PCB-U004	C4017	UTSP C	CE04W50V-22M(UTSP)	1	397582207T	
PCB-U004	C4018	UTSP C	CE04W50V-22M(UTSP)	1	397582207T	
PCB-U004	C4019	MKT C	B32529C0222J289	1	376492224T	
PCB-U004	C4020	MKT C	B32529C0222J289	1	376492224T	
PCB-U004	C4021	UTSP C	CE04W25V-220M(UTSP)	1	397552217T	
PCB-U004	C4022	UTSP C	CE04W25V-220M(UTSP)	1	397552217T	
PCB-U004	C4500	UTSP C	CE04W50V 47M(UTSP)	1	397584707T	
PCB-U004	C4501	UTSP C	CE04W50V 47M(UTSP)	1	397584707T	
PCB-U004	C4502	UTSP C	CE04W50V 47M(UTSP)	1	397584707T	
PCB-U004	C4503	UTSP C	CE04W50V 47M(UTSP)	1	397584707T	
PCB-U004	C4504	UTSP C	CE04W50V 47M(UTSP)	1	397584707T	
PCB-U004	C4505	UTSP C	CE04W50V 47M(UTSP)	1	397584707T	
PCB-U004	C4506	UTSP C	CE04W50V 47M(UTSP)	1	397584707T	
PCB-U004	C4507	UTSP C	CE04W50V 47M(UTSP)	1	397584707T	
PCB-U004	C4508	UTSP C	CE04W50V 47M(UTSP)	1	397584707T	
PCB-U004	C4509	UTSP C	CE04W50V 47M(UTSP)	1	397584707T	
PCB-U004	C4510	UTSP C	CE04W50V 47M(UTSP)	1	397584707T	
PCB-U004	C4511	UTSP C	CE04W50V 47M(UTSP)	1	397584707T	
PCB-U004	C4512	UTSP C	CE04W50V 47M(UTSP)	1	397584707T	
PCB-U004	C4513	UTSP C	CE04W50V 47M(UTSP)	1	397584707T	
PCB-U004	C4514	UTSP C	CE04W50V 47M(UTSP)	1	397584707T	
PCB-U004	C4515	UTSP C	CE04W50V 47M(UTSP)	1	397584707T	
PCB-U004	C4516	UTSP C	CE04W50V 47M(UTSP)	1	397584707T	
PCB-U004	C4517	UTSP C	CE04W50V 47M(UTSP)	1	397584707T	
PCB-U004	C4518	UTSP C	CE04W50V 47M(UTSP)	1	397584707T	
PCB-U004	C4519	UTSP C	CE04W50V 47M(UTSP)	1	397584707T	
PCB-U004	C4520	UTSP C	CE04W50V 47M(UTSP)	1	397584707T	
PCB-U004	C4521	UTSP C	CE04W50V 47M(UTSP)	1	397584707T	
PCB-U004	C4522	UTSP C	CE04W50V-100M(UTSP)	1	397581017T	
PCB-U004	C4523	UTSP C	CE04W50V-100M(UTSP)	1	397581017T	
PCB-U004	C47	UTSP C	CE04W50V-10M(UTSP)	1	397581007T	<MDC>
PCB-U004	C47	UTSP C	CE04W50V-10M(UTSP)	1	397581007T	<MMP, MMO>
PCB-U004	C48	UTSP C	CE04W50V-10M(UTSP)	1	397581007T	<MDC>

PCB-U004	C48	UTSP C	CE04W50V-10M(UTSP)	1	397581007T	<MMP, MMO>
PCB-U004	C4900	CHIP ELECT C	CEWX4V-22M	1	3981G2207R2	
PCB-U004	C4901	CHIP ELECT C	CEWX4V-22M	1	3981G2207R2	
PCB-U004	C4902	CHIP ELECT C	CEWX4V-22M	1	3981G2207R2	<MDC>
PCB-U004	C4902	CHIP ELECT C	CEWX4V-22M	1	3981G2207R2	<MMP, MMO>
PCB-U004	C4903	CHIP ELECT C	CEWX4V-22M	1	3981G2207R2	<MDC>
PCB-U004	C4903	CHIP ELECT C	CEWX4V-22M	1	3981G2207R2	<MMP, MMO>
PCB-U004	C4904	UTSP C	CE04W25V-47M(UTSP)	1	397554707T	
PCB-U004	C4905	UTSP C	CE04W25V-47M(UTSP)	1	397554707T	
PCB-U004	C4906	CHIP ELECT C	CEWX4V-22M	1	3981G2207R2	
PCB-U004	C4907	CHIP ELECT C	CEWX4V-22M	1	3981G2207R2	
PCB-U004	C4908	TF C	ECQ-V50V-333J	1	374723334T	
PCB-U004	C4909	TF C	ECQ-V50V-333J	1	374723334T	
PCB-U004	C4910	TF C	ECQ-V50V-224J	1	374722244T	
PCB-U004	C4911	TF C	ECQ-V50V-473J	1	374724734T	
PCB-U004	C4912	TF C	ECQ-V50V-224J	1	374722244T	
PCB-U004	C4913	TF C	ECQ-V50V-473J	1	374724734T	
PCB-U004	C4914	CHIP ELECT C	CEWX4V-22M	1	3981G2207R2	
PCB-U004	C4915	CHIP ELECT C	CEWX4V-22M	1	3981G2207R2	
PCB-U004	C4916	UTSP C	CE04W25V-220M(UTSP)	1	397552217T	
PCB-U004	C4917	CHIP ELECT C	CEWX4V-22M	1	3981G2207R2	<MDC>
PCB-U004	C4917	CHIP ELECT C	CEWX4V-22M	1	3981G2207R2	<MMP, MMO>
PCB-U004	C4918	CHIP ELECT C	CEWX4V-22M	1	3981G2207R2	<MDC>
PCB-U004	C4918	CHIP ELECT C	CEWX4V-22M	1	3981G2207R2	<MMP, MMO>
PCB-U004	C4919	TF C	ECQ-V50V-333J	1	374723334T	<MDC>
PCB-U004	C4919	TF C	ECQ-V50V-333J	1	374723334T	<MMP, MMO>
PCB-U004	C4920	TF C	ECQ-V50V-333J	1	374723334T	<MDC>
PCB-U004	C4920	TF C	ECQ-V50V-333J	1	374723334T	<MMP, MMO>
PCB-U004	C4921	TF C	ECQ-V50V-224J	1	374722244T	<MDC>
PCB-U004	C4921	TF C	ECQ-V50V-224J	1	374722244T	<MMP, MMO>
PCB-U004	C4922	TF C	ECQ-V50V-473J	1	374724734T	<MDC>
PCB-U004	C4922	TF C	ECQ-V50V-473J	1	374724734T	<MMP, MMO>
PCB-U004	C4923	TF C	ECQ-V50V-224J	1	374722244T	<MDC>

PCB-U004	C4923	TF C	ECQ-V50V-224J	1	374722244T	<MMP, MMO>
PCB-U004	C4924	TF C	ECQ-V50V-473J	1	374724734T	<MDC>
PCB-U004	C4924	TF C	ECQ-V50V-473J	1	374724734T	<MMP, MMO>
PCB-U004	C4925	CHIP ELECT C	CEWX4V-22M	1	3981G2207R2	<MDC>
PCB-U004	C4925	CHIP ELECT C	CEWX4V-22M	1	3981G2207R2	<MMP, MMO>
PCB-U004	C4926	CHIP ELECT C	CEWX4V-22M	1	3981G2207R2	<MDC>
PCB-U004	C4926	CHIP ELECT C	CEWX4V-22M	1	3981G2207R2	<MMP, MMO>
PCB-U004	C4927	UTSP C	CE04W25V-220M(UTSP)	1	397552217T	<MDC>
PCB-U004	C4927	UTSP C	CE04W25V-220M(UTSP)	1	397552217T	<MMP, MMO>
PCB-U004	C4928	CHIP ELECT C	CEWX4V-22M	1	3981G2207R2	
PCB-U004	C4929	CHIP ELECT C	CEWX4V-22M	1	3981G2207R2	
PCB-U004	C4951	CHIP ELECT C	CEWX4V-22M	1	3981G2207R2	<MDC>
PCB-U004	C4951	CHIP ELECT C	CEWX4V-22M	1	3981G2207R2	<MMP, MMO>
PCB-U004	C4952	CHIP ELECT C	CEWX4V-22M	1	3981G2207R2	<MDC>
PCB-U004	C4952	CHIP ELECT C	CEWX4V-22M	1	3981G2207R2	<MMP, MMO>
PCB-U004	C4953	CHIP ELECT C	CEWX4V-22M	1	3981G2207R2	<MDC>
PCB-U004	C4953	CHIP ELECT C	CEWX4V-22M	1	3981G2207R2	<MMP, MMO>
PCB-U004	C4954	CHIP ELECT C	CEWX4V-22M	1	3981G2207R2	<MDC>
PCB-U004	C4954	CHIP ELECT C	CEWX4V-22M	1	3981G2207R2	<MMP, MMO>
PCB-U004	C4963	UTSP C	CE04W25V-47M(UTSP)	1	397554707T	<MDC>
PCB-U004	C4963	UTSP C	CE04W25V-47M(UTSP)	1	397554707T	<MMP, MMO>
PCB-U004	C4964	UTSP C	CE04W25V-47M(UTSP)	1	397554707T	<MDC>
PCB-U004	C4964	UTSP C	CE04W25V-47M(UTSP)	1	397554707T	<MMP, MMO>
PCB-U004	C50	UTSP C	CE04W50V-10M(UTSP)	1	397581007T	<MDC>
PCB-U004	C50	UTSP C	CE04W50V-10M(UTSP)	1	397581007T	<MMP, MMO>
PCB-U004	C51	UTSP C	CE04W50V-10M(UTSP)	1	397581007T	<MDC>
PCB-U004	C51	UTSP C	CE04W50V-10M(UTSP)	1	397581007T	<MMP, MMO>
PCB-U004	C52	UTSP C	CE04W50V-10M(UTSP)	1	397581007T	<MDC>
PCB-U004	C53	UTSP C	CE04W50V-10M(UTSP)	1	397581007T	<MDC>
PCB-U004	C55	UTSP C	CE04W50V-10M(UTSP)	1	397581007T	<MDC>
PCB-U004	C5569	UTSP C	CE04W50V-47M(UTSP)	1	397584707T	
PCB-U004	C5570	UTSP C	CE04W50V-47M(UTSP)	1	397584707T	
PCB-U004	C5571	UTSP C	CE04W50V-47M(UTSP)	1	397584707T	

PCB-U004	C5577	UTSP C	CE04W50V 47M(UTSP)	1	397584707T	
PCB-U004	C5578	UTSP C	CE04W50V 47M(UTSP)	1	397584707T	
PCB-U004	C56	UTSP C	CE04W50V-10M(UTSP)	1	397581007T	<MDC>
PCB-U004	C7001	C-CERA C	CK725F1A-105Z1	1	332181050R1	
PCB-U004	C7002	C-CERA C	CK725F1E-104Z1	1	332161040R1	
PCB-U004	C7004	C-CERA C	CK725F1A-105Z1	1	332181050R1	
PCB-U004	C7005	C-CERA C	CK725F1A-105Z1	1	332181050R1	
PCB-U004	C7006	C-CERA C	CK725F1E-104Z1	1	332161040R1	
PCB-U004	C7007	C-CERA C	CK725F1A-105Z1	1	332181050R1	
PCB-U004	C7008	C-CERA C	CC725CH1H-101J1	1	342101014R1	
PCB-U004	C7009	C-CERA C	CC725CH1H-101J1	1	342101014R1	
PCB-U004	C7012	C-CERA C	CK725B1H-102K1	1	332101025R1	
PCB-U004	C7013	C-CERA C	CK725B1H-102K1	1	332101025R1	
PCB-U004	C7014	UTSP C	CE04W50V-4.7M(UTSP)	1	397580477T	
PCB-U004	C7015	C-CERA C	CK725F1E-104Z1	1	332161040R1	
PCB-U004	C7016	C-CERA C	CK725B1H-102K1	1	332101025R1	
PCB-U004	C7017	C-CERA C	CK725B1H-102K1	1	332101025R1	
PCB-U004	C7018	C-CERA C	CK725B1H-102K1	1	332101025R1	
PCB-U004	C7019	C-CERA C	CK725B1H-102K1	1	332101025R1	
PCB-U004	C7020	C-CERA C	CK725F1E-104Z1	1	332161040R1	
PCB-U004	C7021	C-CERA C	CK725F1E-104Z1	1	332161040R1	
PCB-U004	C7022	C-CERA C	CK725F1E-104Z1	1	332161040R1	
PCB-U004	C7023	C-CERA C	CK725F1E-104Z1	1	332161040R1	
PCB-U004	C7024	C-CERA C	CK725F1E-104Z1	1	332161040R1	
PCB-U004	C7025	C-CERA C	CK725F1E-104Z1	1	332161040R1	
PCB-U004	C7026	C-CERA C	CK725B1H-102K1	1	332101025R1	
PCB-U004	C7027	C-CERA C	CK725F1E-104Z1	1	332161040R1	
PCB-U004	C7028	C-CERA C	CK725F1E-104Z1	1	332161040R1	
PCB-U004	C7029	C-CERA C	CK725F1E-104Z1	1	332161040R1	
PCB-U004	C7030	UTSP C	CE04W50V 47M(UTSP)	1	397584707T	
PCB-U004	C7031	UTSP C	CE04W50V 47M(UTSP)	1	397584707T	
PCB-U004	C7033	C-CERA C	CK725F1E-104Z1	1	332161040R1	
PCB-U004	C7034	VR C	CE04W16V-100M(VR)	1	394641017T	

PCB-U004	C7035	C-CERA C	CK725F1E-104Z1	1	332161040R1	
PCB-U004	C7037	UTSP C	CE04W50V-10M(UTSP)	1	397581007T	
PCB-U004	C7038	UTSP C	CE04W50V 47M(UTSP)	1	397584707T	
PCB-U004	C7039	UTSP C	CE04W50V-10M(UTSP)	1	397581007T	
PCB-U004	C7040	UTSP C	CE04W50V-10M(UTSP)	1	397581007T	
PCB-U004	C7041	VR C	CE04W16V-100M(VR)	1	394641017T	
PCB-U004	C7042	UTSP C	CE04W50V-10M(UTSP)	1	397581007T	
PCB-U004	C7043	VR C	CE04W16V-100M(VR)	1	394641017T	
PCB-U004	C7044	VR C	CE04W16V-100M(VR)	1	394641017T	
PCB-U004	C7046	VR C	CE04W16V-100M(VR)	1	394641017T	
PCB-U004	C7047	C-CERA C	CK725F1E-104Z1	1	332161040R1	
PCB-U004	C7051	VR C	CE04W16V-100M(VR)	1	394641017T	
PCB-U004	C7052	UTSP C	CE04W50V-10M(UTSP)	1	397581007T	
PCB-U004	C7053	VR C	CE04W16V-100M(VR)	1	394641017T	
PCB-U004	C7054	VR C	CE04W16V-100M(VR)	1	394641017T	
PCB-U004	C7055	VR C	CE04W16V-100M(VR)	1	394641017T	
PCB-U004	C7056	C-CERA C	CK725F1A-105Z1	1	332181050R1	
PCB-U004	C7057	UTSP C	CE04W50V-10M(UTSP)	1	397581007T	
PCB-U004	C7058	C-CERA C	CK725F1E-104Z1	1	332161040R1	
PCB-U004	C7059	VR C	CE04W6.3V-470M(VR)	1	394624717T	
PCB-U004	C7060	C-CERA C	CK725F1A-105Z1	1	332181050R1	
PCB-U004	C7061	C-CERA C	CK725F1A-105Z1	1	332181050R1	
PCB-U004	C7302	VR C	CE04W6.3V-470M(VR)	1	394624717T	<MDC>
PCB-U004	C7302	VR C	CE04W6.3V-470M(VR)	1	394624717T	<MMP, MMO>
PCB-U004	C7303	C-CERA C	CK725F1E-104Z1	1	332161040R1	<MDC>
PCB-U004	C7303	C-CERA C	CK725F1E-104Z1	1	332161040R1	<MMP, MMO>
PCB-U004	C7304	C-CERA C	CK725F1E-104Z1	1	332161040R1	
PCB-U004	C7305	C-CERA C	CK725F1A-105Z1	1	332181050R1	
PCB-U004	C7306	C-CERA C	CK725F1A-105Z1	1	332181050R1	
PCB-U004	C7307	C-CERA C	CK725F1A-105Z1	1	332181050R1	
PCB-U004	C7308	C-CERA C	CK725F1A-105Z1	1	332181050R1	
PCB-U004	C7309	C-CERA C	CK725F1A-105Z1	1	332181050R1	
PCB-U004	C7310	C-CERA C	CK725F1A-105Z1	1	332181050R1	

PCB-U004	C7311	C-CERA C	CK725B1H-102K1	1	332101025R1
PCB-U004	C7312	C-CERA C	CK725B1H-102K1	1	332101025R1
PCB-U004	<b>[RESISTOR]</b>				
PCB-U004	R1001	C-CARBON R	RN72K1J-103JE	1	435031034R1
PCB-U004	R1002	C-CARBON R	RN72K1J-103JE	1	435031034R1
PCB-U004	R1003	C-CARBON R	RN72K1J-331JE	1	435033314R1
PCB-U004	R1004	C-CARBON R	RN72K1J-331JE	1	435033314R1
PCB-U004	R1005	C-CARBON R	RN72K1J-331JE	1	435033314R1
PCB-U004	R1006	C-CARBON R	RN72K1J-331JE	1	435033314R1
PCB-U004	R1007	C-CARBON R	RN72K1J-331JE	1	435033314R1
PCB-U004	R1008	C-CARBON R	RN72K1J-331JE	1	435033314R1
PCB-U004	R1009	C-CARBON R	RN72K1J-750JE	1	435037504R1
PCB-U004	R1010	C-CARBON R	RN72K1J-750JE	1	435037504R1
PCB-U004	R1011	C-CARBON R	RN72K1J-103JE	1	435031034R1
PCB-U004	R1012	C-CARBON R	RN72K1J-103JE	1	435031034R1
PCB-U004	R1013	C-CARBON R	RN72K1J-331JE	1	435033314R1
PCB-U004	R1014	C-CARBON R	RN72K1J-331JE	1	435033314R1
PCB-U004	R1015	C-CARBON R	RN72K1J-331JE	1	435033314R1
PCB-U004	R1016	C-CARBON R	RN72K1J-331JE	1	435033314R1
PCB-U004	R1017	C-CARBON R	RN72K1J-331JE	1	435033314R1
PCB-U004	R1018	C-CARBON R	RN72K1J-331JE	1	435033314R1
PCB-U004	R1019	C-CARBON R	RN72K1J-470JE	1	435034704R1
PCB-U004	R1020	C-CARBON R	RN72K1J-470JE	1	435034704R1
PCB-U004	R1021	C-CARBON R	RN72K1J-331JE	1	435033314R1
PCB-U004	R1022	C-CARBON R	RN72K1J-331JE	1	435033314R1
PCB-U004	R1023	C-CARBON R	RN72K1J-103JE	1	435031034R1
PCB-U004	R1024	C-CARBON R	RN72K1J-103JE	1	435031034R1
PCB-U004	R1025	C-CARBON R	RN72K1J-331JE	1	435033314R1
PCB-U004	R1026	C-CARBON R	RN72K1J-331JE	1	435033314R1
PCB-U004	R1027	C-CARBON R	RN72K1J-331JE	1	435033314R1
PCB-U004	R1028	C-CARBON R	RN72K1J-331JE	1	435033314R1
PCB-U004	R1029	C-CARBON R	RN72K1J-331JE	1	435033314R1
PCB-U004	R1030	C-CARBON R	RN72K1J-331JE	1	435033314R1

PCB-U004	R1031	C-CARBON R	RN72K1J-750JE	1	435037504R1
PCB-U004	R1032	C-CARBON R	RN72K1J-750JE	1	435037504R1
PCB-U004	R1033	C-CARBON R	RN72K1J-103JE	1	435031034R1
PCB-U004	R1034	C-CARBON R	RN72K1J-103JE	1	435031034R1
PCB-U004	R1035	C-CARBON R	RN72K1J-331JE	1	435033314R1
PCB-U004	R1036	C-CARBON R	RN72K1J-331JE	1	435033314R1
PCB-U004	R1037	C-CARBON R	RN72K1J-331JE	1	435033314R1
PCB-U004	R1038	C-CARBON R	RN72K1J-331JE	1	435033314R1
PCB-U004	R1039	C-CARBON R	RN72K1J-331JE	1	435033314R1
PCB-U004	R1040	C-CARBON R	RN72K1J-331JE	1	435033314R1
PCB-U004	R1041	C-CARBON R	RN72K1J-470JE	1	435034704R1
PCB-U004	R1042	C-CARBON R	RN72K1J-470JE	1	435034704R1
PCB-U004	R1043	C-CARBON R	RN72K1J-331JE	1	435033314R1
PCB-U004	R1044	C-CARBON R	RN72K1J-331JE	1	435033314R1
PCB-U004	R1045	C-CARBON R	RN72K1J-103JE	1	435031034R1
PCB-U004	R1046	C-CARBON R	RN72K1J-103JE	1	435031034R1
PCB-U004	R1047	C-CARBON R	RN72K1J-331JE	1	435033314R1
PCB-U004	R1048	C-CARBON R	RN72K1J-331JE	1	435033314R1
PCB-U004	R1049	C-CARBON R	RN72K1J-331JE	1	435033314R1
PCB-U004	R1050	C-CARBON R	RN72K1J-331JE	1	435033314R1
PCB-U004	R1051	C-CARBON R	RN72K1J-331JE	1	435033314R1
PCB-U004	R1052	C-CARBON R	RN72K1J-331JE	1	435033314R1
PCB-U004	R1053	C-CARBON R	RN72K1J-750JE	1	435037504R1
PCB-U004	R1054	C-CARBON R	RN72K1J-750JE	1	435037504R1
PCB-U004	R1055	C-CARBON R	RN72K1J-103JE	1	435031034R1
PCB-U004	R1056	C-CARBON R	RN72K1J-103JE	1	435031034R1
PCB-U004	R1057	C-CARBON R	RN72K1J-331JE	1	435033314R1
PCB-U004	R1058	C-CARBON R	RN72K1J-331JE	1	435033314R1
PCB-U004	R1059	C-CARBON R	RN72K1J-331JE	1	435033314R1
PCB-U004	R1060	C-CARBON R	RN72K1J-331JE	1	435033314R1
PCB-U004	R1061	C-CARBON R	RN72K1J-331JE	1	435033314R1
PCB-U004	R1062	C-CARBON R	RN72K1J-331JE	1	435033314R1
PCB-U004	R1063	C-CARBON R	RN72K1J-470JE	1	435034704R1

PCB-U004	R1064	C-CARBON R	RN72K1J-470JE	1	435034704R1	
PCB-U004	R1065	C-CARBON R	RN72K1J-331JE	1	435033314R1	
PCB-U004	R1066	C-CARBON R	RN72K1J-331JE	1	435033314R1	
PCB-U004	R11	METAL O R	RS1/2WBJ-22	1	443522204T	<MDC>
PCB-U004	R11	METAL O R	RS1/2WBJ-22	1	443522204T	<MMP, MMO>
PCB-U004	R1200	C-CARBON R	RN72K1J-821JE	1	435038214R1	
PCB-U004	R1201	C-CARBON R	RN72K1J-821JE	1	435038214R1	
PCB-U004	R1202	C-CARBON R	RN72K1J-821JE	1	435038214R1	
PCB-U004	R1203	C-CARBON R	RN72K1J-821JE	1	435038214R1	
PCB-U004	R1204	C-CARBON R	RN72K1J-821JE	1	435038214R1	
PCB-U004	R1205	C-CARBON R	RN72K1J-821JE	1	435038214R1	
PCB-U004	R1206	C-CARBON R	RN72K1J-821JE	1	435038214R1	
PCB-U004	R1207	C-CARBON R	RN72K1J-821JE	1	435038214R1	
PCB-U004	R1208	C-CARBON R	RN72K1J-821JE	1	435038214R1	
PCB-U004	R1209	C-CARBON R	RN72K1J-821JE	1	435038214R1	
PCB-U004	R1210	C-CARBON R	RN72K1J-821JE	1	435038214R1	
PCB-U004	R1211	C-CARBON R	RN72K1J-821JE	1	435038214R1	
PCB-U004	R1212	C-CARBON R	RN72K1J-821JE	1	435038214R1	
PCB-U004	R1213	C-CARBON R	RN72K1J-821JE	1	435038214R1	
PCB-U004	R1214	C-CARBON R	RN72K1J-821JE	1	435038214R1	
PCB-U004	R1215	C-CARBON R	RN72K1J-821JE	1	435038214R1	
PCB-U004	R1216	C-CARBON R	RN72K1J-821JE	1	435038214R1	
PCB-U004	R1217	C-CARBON R	RN72K1J-821JE	1	435038214R1	
PCB-U004	R1218	C-CARBON R	RN72K1J-821JE	1	435038214R1	
PCB-U004	R1219	C-CARBON R	RN72K1J-821JE	1	435038214R1	
PCB-U004	R1220	C-CARBON R	RN72K1J-271JE	1	435032714R1	<MDC>
PCB-U004	R1220	C-CARBON R	RN72K1J-271JE	1	435032714R1	<MMP, MMO>
PCB-U004	R1221	C-CARBON R	RN72K1J-271JE	1	435032714R1	<MDC>
PCB-U004	R1221	C-CARBON R	RN72K1J-271JE	1	435032714R1	<MMP, MMO>
PCB-U004	R1222	C-CARBON R	RN72K1J-271JE	1	435032714R1	<MDC>
PCB-U004	R1222	C-CARBON R	RN72K1J-271JE	1	435032714R1	<MMP, MMO>
PCB-U004	R1223	C-CARBON R	RN72K1J-271JE	1	435032714R1	<MDC>
PCB-U004	R1223	C-CARBON R	RN72K1J-271JE	1	435032714R1	<MMP, MMO>



PCB-U004	R1224	C-CARBON R	RN72K1J-271JE	1	435032714R1	<MDC>
PCB-U004	R1224	C-CARBON R	RN72K1J-271JE	1	435032714R1	<MMP, MMO>
PCB-U004	R1225	C-CARBON R	RN72K1J-271JE	1	435032714R1	<MDC>
PCB-U004	R1225	C-CARBON R	RN72K1J-271JE	1	435032714R1	<MMP, MMO>
PCB-U004	R1226	C-CARBON R	RN72K1J-271JE	1	435032714R1	<MDC>
PCB-U004	R1226	C-CARBON R	RN72K1J-271JE	1	435032714R1	<MMP, MMO>
PCB-U004	R1227	C-CARBON R	RN72K1J-271JE	1	435032714R1	<MDC>
PCB-U004	R1227	C-CARBON R	RN72K1J-271JE	1	435032714R1	<MMP, MMO>
PCB-U004	R1228	C-CARBON R	RN72K1J-271JE	1	435032714R1	<MDC>
PCB-U004	R1228	C-CARBON R	RN72K1J-271JE	1	435032714R1	<MMP, MMO>
PCB-U004	R1229	C-CARBON R	RN72K1J-271JE	1	435032714R1	<MDC>
PCB-U004	R1229	C-CARBON R	RN72K1J-271JE	1	435032714R1	<MMP, MMO>
PCB-U004	R1230	C-CARBON R	RN72K1J-272JE	1	435032724R1	
PCB-U004	R1231	C-CARBON R	RN72K1J-272JE	1	435032724R1	
PCB-U004	R1232	C-CARBON R	RN72K1J-272JE	1	435032724R1	
PCB-U004	R1233	C-CARBON R	RN72K1J-272JE	1	435032724R1	
PCB-U004	R1234	C-CARBON R	RN72K1J-272JE	1	435032724R1	
PCB-U004	R1235	C-CARBON R	RN72K1J-272JE	1	435032724R1	
PCB-U004	R1236	C-CARBON R	RN72K1J-272JE	1	435032724R1	
PCB-U004	R1237	C-CARBON R	RN72K1J-272JE	1	435032724R1	
PCB-U004	R1238	C-CARBON R	RN72K1J-272JE	1	435032724R1	
PCB-U004	R1239	C-CARBON R	RN72K1J-272JE	1	435032724R1	
PCB-U004	R1240	C-CARBON R	RN72K1J-271JE	1	435032714R1	<MDC>
PCB-U004	R1240	C-CARBON R	RN72K1J-271JE	1	435032714R1	<MMP, MMO>
PCB-U004	R1241	C-CARBON R	RN72K1J-271JE	1	435032714R1	<MDC>
PCB-U004	R1241	C-CARBON R	RN72K1J-271JE	1	435032714R1	<MMP, MMO>
PCB-U004	R1242	C-CARBON R	RN72K1J-271JE	1	435032714R1	<MDC>
PCB-U004	R1242	C-CARBON R	RN72K1J-271JE	1	435032714R1	<MMP, MMO>
PCB-U004	R1243	C-CARBON R	RN72K1J-271JE	1	435032714R1	<MDC>
PCB-U004	R1243	C-CARBON R	RN72K1J-271JE	1	435032714R1	<MMP, MMO>
PCB-U004	R1244	C-CARBON R	RN72K1J-271JE	1	435032714R1	<MDC>
PCB-U004	R1244	C-CARBON R	RN72K1J-271JE	1	435032714R1	<MMP, MMO>
PCB-U004	R1245	C-CARBON R	RN72K1J-271JE	1	435032714R1	<MDC>

PCB-U004	R1245	C-CARBON R	RN72K1J-271JE	1	435032714R1	<MMP, MMO>
PCB-U004	R1246	C-CARBON R	RN72K1J-271JE	1	435032714R1	<MDC>
PCB-U004	R1246	C-CARBON R	RN72K1J-271JE	1	435032714R1	<MMP, MMO>
PCB-U004	R1247	C-CARBON R	RN72K1J-271JE	1	435032714R1	<MDC>
PCB-U004	R1247	C-CARBON R	RN72K1J-271JE	1	435032714R1	<MMP, MMO>
PCB-U004	R1248	C-CARBON R	RN72K1J-271JE	1	435032714R1	<MDC>
PCB-U004	R1248	C-CARBON R	RN72K1J-271JE	1	435032714R1	<MMP, MMO>
PCB-U004	R1249	C-CARBON R	RN72K1J-271JE	1	435032714R1	<MDC>
PCB-U004	R1249	C-CARBON R	RN72K1J-271JE	1	435032714R1	<MMP, MMO>
PCB-U004	R1250	C-CARBON R	RN72K1J-272JE	1	435032724R1	
PCB-U004	R1251	C-CARBON R	RN72K1J-272JE	1	435032724R1	
PCB-U004	R1252	C-CARBON R	RN72K1J-272JE	1	435032724R1	
PCB-U004	R1253	C-CARBON R	RN72K1J-272JE	1	435032724R1	
PCB-U004	R1254	C-CARBON R	RN72K1J-272JE	1	435032724R1	
PCB-U004	R1255	C-CARBON R	RN72K1J-272JE	1	435032724R1	
PCB-U004	R1256	C-CARBON R	RN72K1J-272JE	1	435032724R1	
PCB-U004	R1257	C-CARBON R	RN72K1J-272JE	1	435032724R1	
PCB-U004	R1258	C-CARBON R	RN72K1J-272JE	1	435032724R1	
PCB-U004	R1259	C-CARBON R	RN72K1J-272JE	1	435032724R1	
PCB-U004	R1260	C-CARBON R	RN72K1J-472JE	1	435034724R1	
PCB-U004	R1261	C-CARBON R	RN72K1J-472JE	1	435034724R1	
PCB-U004	R1262	C-CARBON R	RN72K1J-472JE	1	435034724R1	
PCB-U004	R1263	C-CARBON R	RN72K1J-472JE	1	435034724R1	
PCB-U004	R1264	C-CARBON R	RN72K1J-472JE	1	435034724R1	
PCB-U004	R1265	C-CARBON R	RN72K1J-472JE	1	435034724R1	
PCB-U004	R1266	C-CARBON R	RN72K1J-472JE	1	435034724R1	
PCB-U004	R1267	C-CARBON R	RN72K1J-472JE	1	435034724R1	
PCB-U004	R1268	C-CARBON R	RN72K1J-472JE	1	435034724R1	
PCB-U004	R1269	C-CARBON R	RN72K1J-472JE	1	435034724R1	
PCB-U004	R1270	C-CARBON R	RN72K1J-472JE	1	435034724R1	
PCB-U004	R1271	C-CARBON R	RN72K1J-472JE	1	435034724R1	
PCB-U004	R1272	C-CARBON R	RN72K1J-472JE	1	435034724R1	
PCB-U004	R1273	C-CARBON R	RN72K1J-472JE	1	435034724R1	

PCB-U004	R1274	C-CARBON R	RN72K1J-472JE	1	435034724R1	
PCB-U004	R1275	C-CARBON R	RN72K1J-472JE	1	435034724R1	
PCB-U004	R1276	C-CARBON R	RN72K1J-472JE	1	435034724R1	
PCB-U004	R1277	C-CARBON R	RN72K1J-472JE	1	435034724R1	
PCB-U004	R1278	C-CARBON R	RN72K1J-472JE	1	435034724R1	
PCB-U004	R1279	C-CARBON R	RN72K1J-472JE	1	435034724R1	
PCB-U004	R1280	C-CARBON R	RN72K1J-820JE	1	435038204R1	<MDC>
PCB-U004	R1280	C-CARBON R	RN72K1J-820JE	1	435038204R1	<MMP, MMO>
PCB-U004	R1281	C-CARBON R	RN72K1J-820JE	1	435038204R1	<MDC>
PCB-U004	R1281	C-CARBON R	RN72K1J-820JE	1	435038204R1	<MMP, MMO>
PCB-U004	R1282	C-CARBON R	RN72K1J-820JE	1	435038204R1	<MDC>
PCB-U004	R1282	C-CARBON R	RN72K1J-820JE	1	435038204R1	<MMP, MMO>
PCB-U004	R1283	C-CARBON R	RN72K1J-820JE	1	435038204R1	<MDC>
PCB-U004	R1283	C-CARBON R	RN72K1J-820JE	1	435038204R1	<MMP, MMO>
PCB-U004	R1284	C-CARBON R	RN72K1J-820JE	1	435038204R1	<MDC>
PCB-U004	R1284	C-CARBON R	RN72K1J-820JE	1	435038204R1	<MMP, MMO>
PCB-U004	R1285	C-CARBON R	RN72K1J-820JE	1	435038204R1	<MDC>
PCB-U004	R1285	C-CARBON R	RN72K1J-820JE	1	435038204R1	<MMP, MMO>
PCB-U004	R1286	C-CARBON R	RN72K1J-820JE	1	435038204R1	<MDC>
PCB-U004	R1286	C-CARBON R	RN72K1J-820JE	1	435038204R1	<MMP, MMO>
PCB-U004	R1287	C-CARBON R	RN72K1J-820JE	1	435038204R1	<MDC>
PCB-U004	R1287	C-CARBON R	RN72K1J-820JE	1	435038204R1	<MMP, MMO>
PCB-U004	R1288	C-CARBON R	RN72K1J-820JE	1	435038204R1	<MDC>
PCB-U004	R1288	C-CARBON R	RN72K1J-820JE	1	435038204R1	<MMP, MMO>
PCB-U004	R1289	C-CARBON R	RN72K1J-820JE	1	435038204R1	<MDC>
PCB-U004	R1289	C-CARBON R	RN72K1J-820JE	1	435038204R1	<MMP, MMO>
PCB-U004	R1290	C-CARBON R	RN72K1J-820JE	1	435038204R1	<MDC>
PCB-U004	R1290	C-CARBON R	RN72K1J-820JE	1	435038204R1	<MMP, MMO>
PCB-U004	R1291	C-CARBON R	RN72K1J-820JE	1	435038204R1	<MDC>
PCB-U004	R1291	C-CARBON R	RN72K1J-820JE	1	435038204R1	<MMP, MMO>
PCB-U004	R1292	C-CARBON R	RN72K1J-820JE	1	435038204R1	<MDC>
PCB-U004	R1292	C-CARBON R	RN72K1J-820JE	1	435038204R1	<MMP, MMO>
PCB-U004	R1293	C-CARBON R	RN72K1J-820JE	1	435038204R1	<MDC>

PCB-U004	R1293	C-CARBON R	RN72K1J-820JE	1	435038204R1	<MMP, MMO>
PCB-U004	R1294	C-CARBON R	RN72K1J-820JE	1	435038204R1	<MDC>
PCB-U004	R1294	C-CARBON R	RN72K1J-820JE	1	435038204R1	<MMP, MMO>
PCB-U004	R1295	C-CARBON R	RN72K1J-820JE	1	435038204R1	<MDC>
PCB-U004	R1295	C-CARBON R	RN72K1J-820JE	1	435038204R1	<MMP, MMO>
PCB-U004	R1296	C-CARBON R	RN72K1J-820JE	1	435038204R1	<MDC>
PCB-U004	R1296	C-CARBON R	RN72K1J-820JE	1	435038204R1	<MMP, MMO>
PCB-U004	R1297	C-CARBON R	RN72K1J-820JE	1	435038204R1	<MDC>
PCB-U004	R1297	C-CARBON R	RN72K1J-820JE	1	435038204R1	<MMP, MMO>
PCB-U004	R1298	C-CARBON R	RN72K1J-820JE	1	435038204R1	<MDC>
PCB-U004	R1298	C-CARBON R	RN72K1J-820JE	1	435038204R1	<MMP, MMO>
PCB-U004	R1299	C-CARBON R	RN72K1J-820JE	1	435038204R1	<MDC>
PCB-U004	R1299	C-CARBON R	RN72K1J-820JE	1	435038204R1	<MMP, MMO>
PCB-U004	R1300	C-CARBON R	RN72K1J-472JE	1	435034724R1	<MDC>
PCB-U004	R1300	C-CARBON R	RN72K1J-472JE	1	435034724R1	<MMP, MMO>
PCB-U004	R1301	C-CARBON R	RN72K1J-472JE	1	435034724R1	<MDC>
PCB-U004	R1301	C-CARBON R	RN72K1J-472JE	1	435034724R1	<MMP, MMO>
PCB-U004	R1302	C-CARBON R	RN72K1J-472JE	1	435034724R1	<MDC>
PCB-U004	R1302	C-CARBON R	RN72K1J-472JE	1	435034724R1	<MMP, MMO>
PCB-U004	R1303	C-CARBON R	RN72K1J-472JE	1	435034724R1	<MDC>
PCB-U004	R1303	C-CARBON R	RN72K1J-472JE	1	435034724R1	<MMP, MMO>
PCB-U004	R1304	C-CARBON R	RN72K1J-472JE	1	435034724R1	<MDC>
PCB-U004	R1304	C-CARBON R	RN72K1J-472JE	1	435034724R1	<MMP, MMO>
PCB-U004	R1305	C-CARBON R	RN72K1J-472JE	1	435034724R1	<MDC>
PCB-U004	R1305	C-CARBON R	RN72K1J-472JE	1	435034724R1	<MMP, MMO>
PCB-U004	R1306	C-CARBON R	RN72K1J-472JE	1	435034724R1	<MDC>
PCB-U004	R1306	C-CARBON R	RN72K1J-472JE	1	435034724R1	<MMP, MMO>
PCB-U004	R1307	C-CARBON R	RN72K1J-472JE	1	435034724R1	<MDC>
PCB-U004	R1307	C-CARBON R	RN72K1J-472JE	1	435034724R1	<MMP, MMO>
PCB-U004	R1308	C-CARBON R	RN72K1J-472JE	1	435034724R1	<MDC>
PCB-U004	R1308	C-CARBON R	RN72K1J-472JE	1	435034724R1	<MMP, MMO>
PCB-U004	R1309	C-CARBON R	RN72K1J-472JE	1	435034724R1	<MDC>
PCB-U004	R1309	C-CARBON R	RN72K1J-472JE	1	435034724R1	<MMP, MMO>

PCB-U004	R1310	C-CARBON R	RN72K1J-681JE	1	435036814R1	<MDC>
PCB-U004	R1310	C-CARBON R	RN72K1J-681JE	1	435036814R1	<MMP, MMO>
PCB-U004	R1311	C-CARBON R	RN72K1J-681JE	1	435036814R1	<MDC>
PCB-U004	R1311	C-CARBON R	RN72K1J-681JE	1	435036814R1	<MMP, MMO>
PCB-U004	R1312	C-CARBON R	RN72K1J-681JE	1	435036814R1	<MDC>
PCB-U004	R1312	C-CARBON R	RN72K1J-681JE	1	435036814R1	<MMP, MMO>
PCB-U004	R1313	C-CARBON R	RN72K1J-681JE	1	435036814R1	<MDC>
PCB-U004	R1313	C-CARBON R	RN72K1J-681JE	1	435036814R1	<MMP, MMO>
PCB-U004	R1314	C-CARBON R	RN72K1J-681JE	1	435036814R1	<MDC>
PCB-U004	R1314	C-CARBON R	RN72K1J-681JE	1	435036814R1	<MMP, MMO>
PCB-U004	R1315	C-CARBON R	RN72K1J-681JE	1	435036814R1	<MDC>
PCB-U004	R1315	C-CARBON R	RN72K1J-681JE	1	435036814R1	<MMP, MMO>
PCB-U004	R1316	C-CARBON R	RN72K1J-681JE	1	435036814R1	<MDC>
PCB-U004	R1316	C-CARBON R	RN72K1J-681JE	1	435036814R1	<MMP, MMO>
PCB-U004	R1317	C-CARBON R	RN72K1J-681JE	1	435036814R1	<MDC>
PCB-U004	R1317	C-CARBON R	RN72K1J-681JE	1	435036814R1	<MMP, MMO>
PCB-U004	R1318	C-CARBON R	RN72K1J-681JE	1	435036814R1	<MDC>
PCB-U004	R1318	C-CARBON R	RN72K1J-681JE	1	435036814R1	<MMP, MMO>
PCB-U004	R1319	C-CARBON R	RN72K1J-681JE	1	435036814R1	<MDC>
PCB-U004	R1319	C-CARBON R	RN72K1J-681JE	1	435036814R1	<MMP, MMO>
PCB-U004	R1320	C-CARBON R	RN72K1J-472JE	1	435034724R1	<MDC>
PCB-U004	R1320	C-CARBON R	RN72K1J-472JE	1	435034724R1	<MMP, MMO>
PCB-U004	R1321	C-CARBON R	RN72K1J-472JE	1	435034724R1	<MDC>
PCB-U004	R1321	C-CARBON R	RN72K1J-472JE	1	435034724R1	<MMP, MMO>
PCB-U004	R1322	C-CARBON R	RN72K1J-472JE	1	435034724R1	<MDC>
PCB-U004	R1322	C-CARBON R	RN72K1J-472JE	1	435034724R1	<MMP, MMO>
PCB-U004	R1323	C-CARBON R	RN72K1J-472JE	1	435034724R1	<MDC>
PCB-U004	R1323	C-CARBON R	RN72K1J-472JE	1	435034724R1	<MMP, MMO>
PCB-U004	R1324	C-CARBON R	RN72K1J-472JE	1	435034724R1	<MDC>
PCB-U004	R1324	C-CARBON R	RN72K1J-472JE	1	435034724R1	<MMP, MMO>
PCB-U004	R1325	C-CARBON R	RN72K1J-472JE	1	435034724R1	<MDC>
PCB-U004	R1325	C-CARBON R	RN72K1J-472JE	1	435034724R1	<MMP, MMO>
PCB-U004	R1326	C-CARBON R	RN72K1J-472JE	1	435034724R1	<MDC>

PCB-U004	R1326	C-CARBON R	RN72K1J-472JE	1	435034724R1	<MMP, MMO>
PCB-U004	R1327	C-CARBON R	RN72K1J-472JE	1	435034724R1	<MDC>
PCB-U004	R1327	C-CARBON R	RN72K1J-472JE	1	435034724R1	<MMP, MMO>
PCB-U004	R1328	C-CARBON R	RN72K1J-472JE	1	435034724R1	<MDC>
PCB-U004	R1328	C-CARBON R	RN72K1J-472JE	1	435034724R1	<MMP, MMO>
PCB-U004	R1329	C-CARBON R	RN72K1J-472JE	1	435034724R1	<MDC>
PCB-U004	R1329	C-CARBON R	RN72K1J-472JE	1	435034724R1	<MMP, MMO>
PCB-U004	R1330	C-CARBON R	RN72K1J-472JE	1	435034724R1	<MDC>
PCB-U004	R1330	C-CARBON R	RN72K1J-472JE	1	435034724R1	<MMP, MMO>
PCB-U004	R1331	C-CARBON R	RN72K1J-472JE	1	435034724R1	<MDC>
PCB-U004	R1331	C-CARBON R	RN72K1J-472JE	1	435034724R1	<MMP, MMO>
PCB-U004	R1332	C-CARBON R	RN72K1J-472JE	1	435034724R1	<MDC>
PCB-U004	R1332	C-CARBON R	RN72K1J-472JE	1	435034724R1	<MMP, MMO>
PCB-U004	R1333	C-CARBON R	RN72K1J-472JE	1	435034724R1	<MDC>
PCB-U004	R1333	C-CARBON R	RN72K1J-472JE	1	435034724R1	<MMP, MMO>
PCB-U004	R1334	C-CARBON R	RN72K1J-472JE	1	435034724R1	<MDC>
PCB-U004	R1334	C-CARBON R	RN72K1J-472JE	1	435034724R1	<MMP, MMO>
PCB-U004	R1335	C-CARBON R	RN72K1J-472JE	1	435034724R1	<MDC>
PCB-U004	R1335	C-CARBON R	RN72K1J-472JE	1	435034724R1	<MMP, MMO>
PCB-U004	R1336	C-CARBON R	RN72K1J-472JE	1	435034724R1	<MDC>
PCB-U004	R1336	C-CARBON R	RN72K1J-472JE	1	435034724R1	<MMP, MMO>
PCB-U004	R1337	C-CARBON R	RN72K1J-472JE	1	435034724R1	<MDC>
PCB-U004	R1337	C-CARBON R	RN72K1J-472JE	1	435034724R1	<MMP, MMO>
PCB-U004	R1338	C-CARBON R	RN72K1J-472JE	1	435034724R1	<MDC>
PCB-U004	R1338	C-CARBON R	RN72K1J-472JE	1	435034724R1	<MMP, MMO>
PCB-U004	R1339	C-CARBON R	RN72K1J-472JE	1	435034724R1	<MDC>
PCB-U004	R1339	C-CARBON R	RN72K1J-472JE	1	435034724R1	<MMP, MMO>
PCB-U004	R1340	C-CARBON R	RN72K1J-182JE	1	435031824R1	<MDC>
PCB-U004	R1340	C-CARBON R	RN72K1J-182JE	1	435031824R1	<MMP, MMO>
PCB-U004	R1341	C-CARBON R	RN72K1J-182JE	1	435031824R1	<MDC>
PCB-U004	R1341	C-CARBON R	RN72K1J-182JE	1	435031824R1	<MMP, MMO>
PCB-U004	R1342	C-CARBON R	RN72K1J-182JE	1	435031824R1	<MDC>
PCB-U004	R1342	C-CARBON R	RN72K1J-182JE	1	435031824R1	<MMP, MMO>

PCB-U004	R1343	C-CARBON R	RN72K1J-182JE	1	435031824R1	<MDC>
PCB-U004	R1343	C-CARBON R	RN72K1J-182JE	1	435031824R1	<MMP, MMO>
PCB-U004	R1344	C-CARBON R	RN72K1J-182JE	1	435031824R1	<MDC>
PCB-U004	R1344	C-CARBON R	RN72K1J-182JE	1	435031824R1	<MMP, MMO>
PCB-U004	R1345	C-CARBON R	RN72K1J-182JE	1	435031824R1	<MDC>
PCB-U004	R1345	C-CARBON R	RN72K1J-182JE	1	435031824R1	<MMP, MMO>
PCB-U004	R1346	C-CARBON R	RN72K1J-182JE	1	435031824R1	<MDC>
PCB-U004	R1346	C-CARBON R	RN72K1J-182JE	1	435031824R1	<MMP, MMO>
PCB-U004	R1347	C-CARBON R	RN72K1J-182JE	1	435031824R1	<MDC>
PCB-U004	R1347	C-CARBON R	RN72K1J-182JE	1	435031824R1	<MMP, MMO>
PCB-U004	R1348	C-CARBON R	RN72K1J-182JE	1	435031824R1	<MDC>
PCB-U004	R1348	C-CARBON R	RN72K1J-182JE	1	435031824R1	<MMP, MMO>
PCB-U004	R1349	C-CARBON R	RN72K1J-182JE	1	435031824R1	<MDC>
PCB-U004	R1349	C-CARBON R	RN72K1J-182JE	1	435031824R1	<MMP, MMO>
PCB-U004	R1350	C-CARBON R	RN72K1J-561JE	1	435035614R1	<MDC>
PCB-U004	R1350	C-CARBON R	RN72K1J-561JE	1	435035614R1	<MMP, MMO>
PCB-U004	R1351	C-CARBON R	RN72K1J-561JE	1	435035614R1	<MDC>
PCB-U004	R1351	C-CARBON R	RN72K1J-561JE	1	435035614R1	<MMP, MMO>
PCB-U004	R1352	C-CARBON R	RN72K1J-561JE	1	435035614R1	<MDC>
PCB-U004	R1352	C-CARBON R	RN72K1J-561JE	1	435035614R1	<MMP, MMO>
PCB-U004	R1353	C-CARBON R	RN72K1J-561JE	1	435035614R1	<MDC>
PCB-U004	R1353	C-CARBON R	RN72K1J-561JE	1	435035614R1	<MMP, MMO>
PCB-U004	R1354	C-CARBON R	RN72K1J-561JE	1	435035614R1	<MDC>
PCB-U004	R1354	C-CARBON R	RN72K1J-561JE	1	435035614R1	<MMP, MMO>
PCB-U004	R1355	C-CARBON R	RN72K1J-561JE	1	435035614R1	<MDC>
PCB-U004	R1355	C-CARBON R	RN72K1J-561JE	1	435035614R1	<MMP, MMO>
PCB-U004	R1356	C-CARBON R	RN72K1J-561JE	1	435035614R1	<MDC>
PCB-U004	R1356	C-CARBON R	RN72K1J-561JE	1	435035614R1	<MMP, MMO>
PCB-U004	R1357	C-CARBON R	RN72K1J-561JE	1	435035614R1	<MDC>
PCB-U004	R1357	C-CARBON R	RN72K1J-561JE	1	435035614R1	<MMP, MMO>
PCB-U004	R1358	C-CARBON R	RN72K1J-561JE	1	435035614R1	<MDC>
PCB-U004	R1358	C-CARBON R	RN72K1J-561JE	1	435035614R1	<MMP, MMO>
PCB-U004	R1359	C-CARBON R	RN72K1J-561JE	1	435035614R1	<MDC>

PCB-U004	R1359	C-CARBON R	RN72K1J-561JE	1	435035614R1	<MMP, MMO>
PCB-U004	R1360	C-CARBON R	RN72K1J-102JE	1	435031024R1	<MDC>
PCB-U004	R1360	C-CARBON R	RN72K1J-102JE	1	435031024R1	<MMP, MMO>
PCB-U004	R1361	C-CARBON R	RN72K1J-102JE	1	435031024R1	<MDC>
PCB-U004	R1361	C-CARBON R	RN72K1J-102JE	1	435031024R1	<MMP, MMO>
PCB-U004	R1362	C-CARBON R	RN72K1J-102JE	1	435031024R1	<MDC>
PCB-U004	R1362	C-CARBON R	RN72K1J-102JE	1	435031024R1	<MMP, MMO>
PCB-U004	R1363	C-CARBON R	RN72K1J-102JE	1	435031024R1	<MDC>
PCB-U004	R1363	C-CARBON R	RN72K1J-102JE	1	435031024R1	<MMP, MMO>
PCB-U004	R1364	C-CARBON R	RN72K1J-102JE	1	435031024R1	<MDC>
PCB-U004	R1364	C-CARBON R	RN72K1J-102JE	1	435031024R1	<MMP, MMO>
PCB-U004	R1365	C-CARBON R	RN72K1J-102JE	1	435031024R1	<MDC>
PCB-U004	R1365	C-CARBON R	RN72K1J-102JE	1	435031024R1	<MMP, MMO>
PCB-U004	R1366	C-CARBON R	RN72K1J-102JE	1	435031024R1	<MDC>
PCB-U004	R1366	C-CARBON R	RN72K1J-102JE	1	435031024R1	<MMP, MMO>
PCB-U004	R1367	C-CARBON R	RN72K1J-102JE	1	435031024R1	<MDC>
PCB-U004	R1367	C-CARBON R	RN72K1J-102JE	1	435031024R1	<MMP, MMO>
PCB-U004	R1368	C-CARBON R	RN72K1J-102JE	1	435031024R1	<MDC>
PCB-U004	R1368	C-CARBON R	RN72K1J-102JE	1	435031024R1	<MMP, MMO>
PCB-U004	R1369	C-CARBON R	RN72K1J-102JE	1	435031024R1	<MDC>
PCB-U004	R1369	C-CARBON R	RN72K1J-102JE	1	435031024R1	<MMP, MMO>
PCB-U004	R1370	C-CARBON R	RN72K1J-152JE	1	435031524R1	<MDC>
PCB-U004	R1370	C-CARBON R	RN72K1J-152JE	1	435031524R1	<MMP, MMO>
PCB-U004	R1371	C-CARBON R	RN72K1J-152JE	1	435031524R1	<MDC>
PCB-U004	R1371	C-CARBON R	RN72K1J-152JE	1	435031524R1	<MMP, MMO>
PCB-U004	R1372	C-CARBON R	RN72K1J-272JE	1	435032724R1	<MDC>
PCB-U004	R1372	C-CARBON R	RN72K1J-272JE	1	435032724R1	<MMP, MMO>
PCB-U004	R1373	C-CARBON R	RN72K1J-152JE	1	435031524R1	<MDC>
PCB-U004	R1373	C-CARBON R	RN72K1J-152JE	1	435031524R1	<MMP, MMO>
PCB-U004	R1374	C-CARBON R	RN72K1J-152JE	1	435031524R1	<MDC>
PCB-U004	R1374	C-CARBON R	RN72K1J-152JE	1	435031524R1	<MMP, MMO>
PCB-U004	R1375	C-CARBON R	RN72K1J-152JE	1	435031524R1	<MDC>
PCB-U004	R1375	C-CARBON R	RN72K1J-152JE	1	435031524R1	<MMP, MMO>



PCB-U004	R1376	C-CARBON R	RN72K1J-152JE	1	435031524R1	<MDC>
PCB-U004	R1376	C-CARBON R	RN72K1J-152JE	1	435031524R1	<MMP, MMO>
PCB-U004	R1377	C-CARBON R	RN72K1J-152JE	1	435031524R1	<MDC>
PCB-U004	R1377	C-CARBON R	RN72K1J-152JE	1	435031524R1	<MMP, MMO>
PCB-U004	R1378	C-CARBON R	RN72K1J-152JE	1	435031524R1	<MDC>
PCB-U004	R1378	C-CARBON R	RN72K1J-152JE	1	435031524R1	<MMP, MMO>
PCB-U004	R1379	C-CARBON R	RN72K1J-152JE	1	435031524R1	<MDC>
PCB-U004	R1379	C-CARBON R	RN72K1J-152JE	1	435031524R1	<MMP, MMO>
PCB-U004	R1380	C-CARBON R	RN72K1J-272JE	1	435032724R1	<MDC>
PCB-U004	R1380	C-CARBON R	RN72K1J-272JE	1	435032724R1	<MMP, MMO>
PCB-U004	R1381	C-CARBON R	RN72K1J-272JE	1	435032724R1	<MDC>
PCB-U004	R1381	C-CARBON R	RN72K1J-272JE	1	435032724R1	<MMP, MMO>
PCB-U004	R1382	C-CARBON R	RN72K1J-152JE	1	435031524R1	<MDC>
PCB-U004	R1382	C-CARBON R	RN72K1J-152JE	1	435031524R1	<MMP, MMO>
PCB-U004	R1383	C-CARBON R	RN72K1J-272JE	1	435032724R1	<MDC>
PCB-U004	R1383	C-CARBON R	RN72K1J-272JE	1	435032724R1	<MMP, MMO>
PCB-U004	R1384	C-CARBON R	RN72K1J-272JE	1	435032724R1	<MDC>
PCB-U004	R1384	C-CARBON R	RN72K1J-272JE	1	435032724R1	<MMP, MMO>
PCB-U004	R1385	C-CARBON R	RN72K1J-272JE	1	435032724R1	<MDC>
PCB-U004	R1385	C-CARBON R	RN72K1J-272JE	1	435032724R1	<MMP, MMO>
PCB-U004	R1386	C-CARBON R	RN72K1J-272JE	1	435032724R1	<MDC>
PCB-U004	R1386	C-CARBON R	RN72K1J-272JE	1	435032724R1	<MMP, MMO>
PCB-U004	R1387	C-CARBON R	RN72K1J-272JE	1	435032724R1	<MDC>
PCB-U004	R1387	C-CARBON R	RN72K1J-272JE	1	435032724R1	<MMP, MMO>
PCB-U004	R1388	C-CARBON R	RN72K1J-272JE	1	435032724R1	<MDC>
PCB-U004	R1388	C-CARBON R	RN72K1J-272JE	1	435032724R1	<MMP, MMO>
PCB-U004	R1389	C-CARBON R	RN72K1J-272JE	1	435032724R1	<MDC>
PCB-U004	R1389	C-CARBON R	RN72K1J-272JE	1	435032724R1	<MMP, MMO>
PCB-U004	R1400	C-CARBON R	RN72K2E-100JE	1	435221004R1	
PCB-U004	R1401	C-CARBON R	RN72K2E-100JE	1	435221004R1	
PCB-U004	R1402	C-CARBON R	RN72K2E-100JE	1	435221004R1	
PCB-U004	R1403	C-CARBON R	RN72K2E-100JE	1	435221004R1	
PCB-U004	R1404	C-CARBON R	RN72K2E-100JE	1	435221004R1	

PCB-U004	R1405	C-CARBON R	RN72K2E-100JE	1	435221004R1	
PCB-U004	R1406	C-CARBON R	RN72K2E-100JE	1	435221004R1	
PCB-U004	R1407	C-CARBON R	RN72K2E-100JE	1	435221004R1	
PCB-U004	R1408	C-CARBON R	RN72K2E-100JE	1	435221004R1	
PCB-U004	R1409	C-CARBON R	RN72K2E-100JE	1	435221004R1	
PCB-U004	R1410	C-CARBON R	RN72K1J-821JE	1	435038214R1	
PCB-U004	R1411	C-CARBON R	RN72K1J-821JE	1	435038214R1	
PCB-U004	R1420	C-CARBON R	RN72K1J-821JE	1	435038214R1	
PCB-U004	R1421	C-CARBON R	RN72K1J-821JE	1	435038214R1	
PCB-U004	R1430	C-CARBON R	RN72K1J-271JE	1	435032714R1	<MDC>
PCB-U004	R1430	C-CARBON R	RN72K1J-271JE	1	435032714R1	<MMP, MMO>
PCB-U004	R1431	C-CARBON R	RN72K1J-271JE	1	435032714R1	<MDC>
PCB-U004	R1431	C-CARBON R	RN72K1J-271JE	1	435032714R1	<MMP, MMO>
PCB-U004	R1440	C-CARBON R	RN72K1J-272JE	1	435032724R1	
PCB-U004	R1441	C-CARBON R	RN72K1J-272JE	1	435032724R1	
PCB-U004	R1450	C-CARBON R	RN72K1J-271JE	1	435032714R1	<MDC>
PCB-U004	R1450	C-CARBON R	RN72K1J-271JE	1	435032714R1	<MMP, MMO>
PCB-U004	R1451	C-CARBON R	RN72K1J-271JE	1	435032714R1	<MDC>
PCB-U004	R1451	C-CARBON R	RN72K1J-271JE	1	435032714R1	<MMP, MMO>
PCB-U004	R1460	C-CARBON R	RN72K1J-272JE	1	435032724R1	
PCB-U004	R1461	C-CARBON R	RN72K1J-272JE	1	435032724R1	
PCB-U004	R1470	C-CARBON R	RN72K1J-472JE	1	435034724R1	
PCB-U004	R1471	C-CARBON R	RN72K1J-472JE	1	435034724R1	
PCB-U004	R1480	C-CARBON R	RN72K1J-472JE	1	435034724R1	
PCB-U004	R1481	C-CARBON R	RN72K1J-472JE	1	435034724R1	
PCB-U004	R1490	C-CARBON R	RN72K1J-820JE	1	435038204R1	<MDC>
PCB-U004	R1490	C-CARBON R	RN72K1J-820JE	1	435038204R1	<MMP, MMO>
PCB-U004	R1491	C-CARBON R	RN72K1J-820JE	1	435038204R1	<MDC>
PCB-U004	R1491	C-CARBON R	RN72K1J-820JE	1	435038204R1	<MMP, MMO>
PCB-U004	R1500	C-CARBON R	RN72K1J-820JE	1	435038204R1	<MDC>
PCB-U004	R1500	C-CARBON R	RN72K1J-820JE	1	435038204R1	<MMP, MMO>
PCB-U004	R1501	C-CARBON R	RN72K1J-820JE	1	435038204R1	<MDC>
PCB-U004	R1501	C-CARBON R	RN72K1J-820JE	1	435038204R1	<MMP, MMO>

PCB-U004	R1510	C-CARBON R	RN72K1J-472JE	1	435034724R1
PCB-U004	R1511	C-CARBON R	RN72K1J-472JE	1	435034724R1
PCB-U004	R1520	C-CARBON R	RN72K1J-681JE	1	435036814R1
PCB-U004	R1521	C-CARBON R	RN72K1J-681JE	1	435036814R1
PCB-U004	R1530	C-CARBON R	RN72K1J-472JE	1	435034724R1
PCB-U004	R1531	C-CARBON R	RN72K1J-472JE	1	435034724R1
PCB-U004	R1540	C-CARBON R	RN72K1J-472JE	1	435034724R1
PCB-U004	R1541	C-CARBON R	RN72K1J-472JE	1	435034724R1
PCB-U004	R1550	C-CARBON R	RN72K1J-182JE	1	435031824R1
PCB-U004	R1551	C-CARBON R	RN72K1J-182JE	1	435031824R1
PCB-U004	R1560	C-CARBON R	RN72K1J-272JE	1	435032724R1
PCB-U004	R1561	C-CARBON R	RN72K1J-272JE	1	435032724R1
PCB-U004	R1570	C-CARBON R	RN72K1J-152JE	1	435031524R1
PCB-U004	R1571	C-CARBON R	RN72K1J-152JE	1	435031524R1
PCB-U004	R1580	C-CARBON R	RN72K1J-102JE	1	435031024R1
PCB-U004	R1581	C-CARBON R	RN72K1J-102JE	1	435031024R1
PCB-U004	R1590	C-CARBON R	RN72K1J-561JE	1	435035614R1
PCB-U004	R1591	C-CARBON R	RN72K1J-561JE	1	435035614R1
PCB-U004	R1610	C-CARBON R	RN72K2E-100JE	1	435221004R1
PCB-U004	R1611	C-CARBON R	RN72K2E-100JE	1	435221004R1
PCB-U004	R1620	C-CARBON R	RN72K1J-103JE	1	435031034R1
PCB-U004	R1621	C-CARBON R	RN72K1J-103JE	1	435031034R1
PCB-U004	R1622	C-CARBON R	RN72K1J-103JE	1	435031034R1
PCB-U004	R1623	C-CARBON R	RN72K1J-103JE	1	435031034R1
PCB-U004	R1624	C-CARBON R	RN72K1J-103JE	1	435031034R1
PCB-U004	R1625	C-CARBON R	RN72K1J-103JE	1	435031034R1
PCB-U004	R1626	C-CARBON R	RN72K1J-103JE	1	435031034R1
PCB-U004	R1627	C-CARBON R	RN72K1J-103JE	1	435031034R1
PCB-U004	R1628	C-CARBON R	RN72K1J-103JE	1	435031034R1
PCB-U004	R1629	C-CARBON R	RN72K1J-103JE	1	435031034R1
PCB-U004	R1630	C-CARBON R	RN72K1J-103JE	1	435031034R1
PCB-U004	R1631	C-CARBON R	RN72K1J-103JE	1	435031034R1
PCB-U004	R1632	C-CARBON R	RN72K1J-103JE	1	435031034R1

PCB-U004	R1633	C-CARBON R	RN72K1J-103JE	1	435031034R1	
PCB-U004	R1634	C-CARBON R	RN72K1J-103JE	1	435031034R1	
PCB-U004	R1635	C-CARBON R	RN72K1J-103JE	1	435031034R1	
PCB-U004	R1636	C-CARBON R	RN72K1J-103JE	1	435031034R1	
PCB-U004	R1637	C-CARBON R	RN72K1J-103JE	1	435031034R1	
PCB-U004	R1638	C-CARBON R	RN72K1J-103JE	1	435031034R1	
PCB-U004	R1639	C-CARBON R	RN72K1J-103JE	1	435031034R1	
PCB-U004	R1640	C-CARBON R	RN72K1J-103JE	1	435031034R1	
PCB-U004	R1641	C-CARBON R	RN72K1J-103JE	1	435031034R1	
PCB-U004	R1642	C-CARBON R	RN72K1J-103JE	1	435031034R1	
PCB-U004	R1643	C-CARBON R	RN72K1J-103JE	1	435031034R1	
PCB-U004	R1644	C-CARBON R	RN72K1J-103JE	1	435031034R1	
PCB-U004	R1645	C-CARBON R	RN72K1J-103JE	1	435031034R1	
PCB-U004	R1646	C-CARBON R	RN72K1J-103JE	1	435031034R1	
PCB-U004	R1647	C-CARBON R	RN72K1J-103JE	1	435031034R1	
PCB-U004	R1648	C-CARBON R	RN72K1J-103JE	1	435031034R1	
PCB-U004	R1649	C-CARBON R	RN72K1J-103JE	1	435031034R1	
PCB-U004	R1660	C-CARBON R	RN72K1J-103JE	1	435031034R1	
PCB-U004	R1661	C-CARBON R	RN72K1J-103JE	1	435031034R1	
PCB-U004	R1670	C-CARBON R	RN72K1J-103JE	1	435031034R1	
PCB-U004	R1671	C-CARBON R	RN72K1J-103JE	1	435031034R1	
PCB-U004	R1680	C-CARBON R	RN72K1J-103JE	1	435031034R1	
PCB-U004	R1681	C-CARBON R	RN72K1J-103JE	1	435031034R1	
PCB-U004	R1682	C-CARBON R	RN72K1J-273JE	1	435032734R1	
PCB-U004	R1683	C-CARBON R	RN72K1J-103JE	1	435031034R1	
PCB-U004	R1684	C-CARBON R	RN72K1J-273JE	1	435032734R1	
PCB-U004	R1685	C-CARBON R	RN72K1J-103JE	1	435031034R1	
PCB-U004	R32	METAL O R	RS1/2WBJ-22	1	443522204T	<MDC>
PCB-U004	R32	METAL O R	RS1/2WBJ-22	1	443522204T	<MMP, MMO>
PCB-U004	R3702	C-CARBON R	RN72K1J-750JE	1	435037504R1	
PCB-U004	R3703	C-CARBON R	RN72K1J-220JE	1	435032204R1	
PCB-U004	R3707	C-CARBON R	RN72K1J-151JE	1	435031514R1	
PCB-U004	R3708	C-CARBON R	RN72K1J-151JE	1	435031514R1	

PCB-U004	R3709	C-CARBON R	RN72K1J-151JE	1	435031514R1
PCB-U004	R3710	C-CARBON R	RN72K1J-221JE	1	435032214R1
PCB-U004	R3711	C-CARBON R	RN72K1J-151JE	1	435031514R1
PCB-U004	R3712	C-CARBON R	RN72K1J-331JE	1	435033314R1
PCB-U004	R3713	C-CARBON R	RN72K1J-331JE	1	435033314R1
PCB-U004	R3714	C-CARBON R	RN72K1J-151JE	1	435031514R1
PCB-U004	R3715	C-CARBON R	RN72K1J-331JE	1	435033314R1
PCB-U004	R3716	C-CARBON R	RN72K1J-151JE	1	435031514R1
PCB-U004	R3717	C-CARBON R	RN72K1J-331JE	1	435033314R1
PCB-U004	R3719	C-CARBON R	RN72K1J-331JE	1	435033314R1
PCB-U004	R3720	C-CARBON R	RN72K1J-470JE	1	435034704R1
PCB-U004	R3721	C-CARBON R	RN72K1J-331JE	1	435033314R1
PCB-U004	R3722	C-CARBON R	RN72K1J-220JE	1	435032204R1
PCB-U004	R3723	C-CARBON R	RN72K1J-331JE	1	435033314R1
PCB-U004	R3724	C-CARBON R	RN72K1J-331JE	1	435033314R1
PCB-U004	R3725	C-CARBON R	RN72K1J-331JE	1	435033314R1
PCB-U004	R3726	C-CARBON R	RN72K1J-750JE	1	435037504R1
PCB-U004	R3727	C-CARBON R	RN72K1J-220JE	1	435032204R1
PCB-U004	R3728	C-CARBON R	RN72K1J-151JE	1	435031514R1
PCB-U004	R3729	C-CARBON R	RN72K1J-392JE	1	435033924R1
PCB-U004	R3730	C-CARBON R	RN72K1J-392JE	1	435033924R1
PCB-U004	R3731	C-CARBON R	RN72K1J-220JE	1	435032204R1
PCB-U004	R3732	C-CARBON R	RN72K1J-220JE	1	435032204R1
PCB-U004	R3733	C-CARBON R	RN72K1J-151JE	1	435031514R1
PCB-U004	R3734	C-CARBON R	RN72K1J-220JE	1	435032204R1
PCB-U004	R3735	C-CARBON R	RN72K1J-151JE	1	435031514R1
PCB-U004	R3736	C-CARBON R	RN72K1J-221JE	1	435032214R1
PCB-U004	R3737	C-CARBON R	RN72K1J-151JE	1	435031514R1
PCB-U004	R3738	C-CARBON R	RN72K1J-470JE	1	435034704R1
PCB-U004	R3739	C-CARBON R	RN72K1J-331JE	1	435033314R1
PCB-U004	R3740	C-CARBON R	RN72K1J-152JE	1	435031524R1
PCB-U004	R3741	C-CARBON R	RN72K1J-151JE	1	435031514R1
PCB-U004	R3742	C-CARBON R	RN72K1J-331JE	1	435033314R1

PCB-U004	R3743	C-CARBON R	RN72K1J-151JE	1	435031514R1
PCB-U004	R3744	C-CARBON R	RN72K1J-331JE	1	435033314R1
PCB-U004	R3745	C-CARBON R	RN72K1J-470JE	1	435034704R1
PCB-U004	R3746	C-CARBON R	RN72K1J-331JE	1	435033314R1
PCB-U004	R3747	C-CARBON R	RN72K1J-331JE	1	435033314R1
PCB-U004	R3748	C-CARBON R	RN72K1J-331JE	1	435033314R1
PCB-U004	R3749	C-CARBON R	RN72K1J-331JE	1	435033314R1
PCB-U004	R3750	C-CARBON R	RN72K1J-331JE	1	435033314R1
PCB-U004	R3751	C-CARBON R	RN72K1J-331JE	1	435033314R1
PCB-U004	R3752	C-CARBON R	RN72K1J-331JE	1	435033314R1
PCB-U004	R3754	C-CARBON R	RN72K1J-331JE	1	435033314R1
PCB-U004	R3755	C-CARBON R	RN72K1J-331JE	1	435033314R1
PCB-U004	R3756	C-CARBON R	RN72K1J-331JE	1	435033314R1
PCB-U004	R3757	C-CARBON R	RN72K1J-331JE	1	435033314R1
PCB-U004	R3758	C-CARBON R	RN72K1J-331JE	1	435033314R1
PCB-U004	R3759	C-CARBON R	RN72K1J-331JE	1	435033314R1
PCB-U004	R3760	C-CARBON R	RN72K1J-331JE	1	435033314R1
PCB-U004	R3761	C-CARBON R	RN72K1J-331JE	1	435033314R1
PCB-U004	R3762	C-CARBON R	RN72K1J-331JE	1	435033314R1
PCB-U004	R3763	C-CARBON R	RN72K1J-331JE	1	435033314R1
PCB-U004	R3765	C-CARBON R	RN72K1J-103JE	1	435031034R1
PCB-U004	R3766	C-CARBON R	RN72K1J-331JE	1	435033314R1
PCB-U004	R3767	C-CARBON R	RN72K1J-331JE	1	435033314R1
PCB-U004	R3768	C-CARBON R	RN72K1J-331JE	1	435033314R1
PCB-U004	R3769	C-CARBON R	RN72K1J-470JE	1	435034704R1
PCB-U004	R3770	C-CARBON R	RN72K1J-470JE	1	435034704R1
PCB-U004	R3771	C-CARBON R	RN72K1J-221JE	1	435032214R1
PCB-U004	R3772	C-CARBON R	RN72K1J-470JE	1	435034704R1
PCB-U004	R3773	C-CARBON R	RN72K1J-105JE	1	435031054R1
PCB-U004	R3774	C-CARBON R	RN72K1J-470JE	1	435034704R1
PCB-U004	R3775	C-CARBON R	RN72K1J-470JE	1	435034704R1
PCB-U004	R3776	C-CARBON R	RN72K1J-000JE	1	435030004R1
PCB-U004	R3777	C-CARBON R	RN72K1J-391JE	1	435033914R1

PCB-U004	R3778	C-CARBON R	RN72K1J-391JE	1	435033914R1
PCB-U004	R3779	C-CARBON R	RN72K1J-103JE	1	435031034R1
PCB-U004	R3780	C-CARBON R	RN72K1J-103JE	1	435031034R1
PCB-U004	R3781	C-CARBON R	RN72K1J-103JE	1	435031034R1
PCB-U004	R3782	C-CARBON R	RN72K1J-103JE	1	435031034R1
PCB-U004	R3783	C-CARBON R	RN72K1J-103JE	1	435031034R1
PCB-U004	R3784	C-CARBON R	RN72K1J-103JE	1	435031034R1
PCB-U004	R3785	C-CARBON R	RN72K1J-103JE	1	435031034R1
PCB-U004	R3786	C-CARBON R	RN72K1J-103JE	1	435031034R1
PCB-U004	R3787	C-CARBON R	RN72K1J-103JE	1	435031034R1
PCB-U004	R3788	C-CARBON R	RN72K1J-103JE	1	435031034R1
PCB-U004	R3789	C-CARBON R	RN72K1J-560JE	1	435035604R1
PCB-U004	R3790	C-CARBON R	RN72K1J-560JE	1	435035604R1
PCB-U004	R3791	C-CARBON R	RN72K1J-560JE	1	435035604R1
PCB-U004	R3792	C-CARBON R	RN72K1J-560JE	1	435035604R1
PCB-U004	R3796	C-CARBON R	RN72K1J-103JE	1	435031034R1
PCB-U004	R3797	C-CARBON R	RN72K1J-103JE	1	435031034R1
PCB-U004	R3798	C-CARBON R	RN72K1J-103JE	1	435031034R1
PCB-U004	R3799	C-CARBON R	RN72K1J-103JE	1	435031034R1
PCB-U004	R3883	C-CARBON R	RN72K1J-331JE	1	435033314R1
PCB-U004	R3884	C-CARBON R	RN72K1J-221JE	1	435032214R1
PCB-U004	R3885	C-CARBON R	RN72K1J-103JE	1	435031034R1
PCB-U004	R3886	C-CARBON R	RN72K1J-221JE	1	435032214R1
PCB-U004	R3887	C-CARBON R	RN72K1J-470JE	1	435034704R1
PCB-U004	R3888	C-CARBON R	RN72K1J-470JE	1	435034704R1
PCB-U004	R3889	C-CARBON R	RN72K1J-470JE	1	435034704R1
PCB-U004	R3890	C-CARBON R	RN72K1J-470JE	1	435034704R1
PCB-U004	R3891	C-CARBON R	RN72K1J-470JE	1	435034704R1
PCB-U004	R3892	C-CARBON R	RN72K1J-823JE	1	435038234R1
PCB-U004	R3893	C-CARBON R	RN72K1J-103JE	1	435031034R1
PCB-U004	R3894	C-CARBON R	RN72K1J-103JE	1	435031034R1
PCB-U004	R3895	C-CARBON R	RN72K1J-100JE	1	435031004R1
PCB-U004	R3896	C-CARBON R	RN72K1J-823JE	1	435038234R1

PCB-U004	R3897	C-CARBON R	RN72K1J-750JE	1	435037504R1	
PCB-U004	R3898	C-CARBON R	RN72K1J-224JE	1	435032244R1	
PCB-U004	R3899	C-CARBON R	RN72K1J-103JE	1	435031034R1	
PCB-U004	R39	C-CARBON R	RN72K1J-220JE	1	435032204R1	<MDC>
PCB-U004	R3900	C-CARBON R	RN72K1J-823JE	1	435038234R1	
PCB-U004	R3901	C-CARBON R	RN72K1J-470JE	1	435034704R1	
PCB-U004	R3902	C-CARBON R	RN72K1J-470JE	1	435034704R1	
PCB-U004	R3903	C-CARBON R	RN72K1J-103JE	1	435031034R1	
PCB-U004	R3904	C-CARBON R	RN72K1J-103JE	1	435031034R1	
PCB-U004	R3905	C-CARBON R	RN72K1J-331JE	1	435033314R1	
PCB-U004	R3906	C-CARBON R	RN72K1J-331JE	1	435033314R1	
PCB-U004	R3907	C-CARBON R	RN72K1J-103JE	1	435031034R1	
PCB-U004	R3908	C-CARBON R	RN72K1J-331JE	1	435033314R1	
PCB-U004	R3910	C-CARBON R	RN72K1J-331JE	1	435033314R1	
PCB-U004	R3911	C-CARBON R	RN72K1J-221JE	1	435032214R1	
PCB-U004	R3913	C-CARBON R	RN72K1J-750JE	1	435037504R1	
PCB-U004	R3914	C-CARBON R	RN72K1J-100JE	1	435031004R1	
PCB-U004	R3915	C-CARBON R	RN72K1J-224JE	1	435032244R1	
PCB-U004	R3916	C-CARBON R	RN72K1J-470JE	1	435034704R1	
PCB-U004	R3917	C-CARBON R	RN72K1J-470JE	1	435034704R1	
PCB-U004	R3918	C-CARBON R	RN72K1J-331JE	1	435033314R1	
PCB-U004	R3919	C-CARBON R	RN72K1J-331JE	1	435033314R1	
PCB-U004	R3920	C-CARBON R	RN72K1J-331JE	1	435033314R1	
PCB-U004	R3921	C-CARBON R	RN72K1J-750JE	1	435037504R1	
PCB-U004	R3922	C-CARBON R	RN72K1J-224JE	1	435032244R1	
PCB-U004	R3923	C-CARBON R	RN72K1J-100JE	1	435031004R1	
PCB-U004	R4005	C-CARBON R	RN72K1J-102JE	1	435031024R1	
PCB-U004	R4006	C-CARBON R	RN72K1J-102JE	1	435031024R1	
PCB-U004	R4007	METAL O R	RS1/2WBJ-2.2K	1	443522224T	
PCB-U004	R4008	METAL O R	RS1/2WBJ-2.2K	1	443522224T	
PCB-U004	R4009	C-CARBON R	RN72K1J-223JE	1	435032234R1	
PCB-U004	R4010	C-CARBON R	RN72K1J-223JE	1	435032234R1	
PCB-U004	R4011	C-CARBON R	RN72K1J-224JE	1	435032244R1	



PCB-U004	R4012	C-CARBON R	RN72K1J-224JE	1	435032244R1	
PCB-U004	R4013	C-CARBON R	RN72K1J-221JE	1	435032214R1	
PCB-U004	R4014	C-CARBON R	RN72K1J-221JE	1	435032214R1	
PCB-U004	R4015	C-CARBON R	RN72K1J-332JE	1	435033324R1	
PCB-U004	R4016	C-CARBON R	RN72K1J-332JE	1	435033324R1	
PCB-U004	R4017	C-CARBON R	RN72K1J-220JE	1	435032204R1	
PCB-U004	R4018	C-CARBON R	RN72K1J-220JE	1	435032204R1	
PCB-U004	R4019	C-CARBON R	RN72K1J-332JE	1	435033324R1	
PCB-U004	R4020	C-CARBON R	RN72K1J-332JE	1	435033324R1	
PCB-U004	R4021	C-CARBON R	RN72K1J-220JE	1	435032204R1	
PCB-U004	R4022	C-CARBON R	RN72K1J-220JE	1	435032204R1	
PCB-U004	R4023	C-CARBON R	RN72K1J-272JE	1	435032724R1	
PCB-U004	R4024	C-CARBON R	RN72K1J-272JE	1	435032724R1	
PCB-U004	R4025	C-CARBON R	RN72K1J-821JE	1	435038214R1	
PCB-U004	R4026	C-CARBON R	RN72K1J-821JE	1	435038214R1	
PCB-U004	R4027	C-CARBON R	RN72K1J-474JE	1	435034744R1	
PCB-U004	R4028	C-CARBON R	RN72K1J-474JE	1	435034744R1	
PCB-U004	R4029	C-CARBON R	RN72K1J-393JE	1	435033934R1	
PCB-U004	R4030	C-CARBON R	RN72K1J-393JE	1	435033934R1	
PCB-U004	R4031	C-CARBON R	RN72K1J-122JE	1	435031224R1	
PCB-U004	R4032	C-CARBON R	RN72K1J-122JE	1	435031224R1	
PCB-U004	R4033	C-CARBON R	RN72K1J-821JE	1	435038214R1	
PCB-U004	R4034	C-CARBON R	RN72K1J-821JE	1	435038214R1	
PCB-U004	R4035	C-CARBON R	RN72K1J-224JE	1	435032244R1	
PCB-U004	R4036	C-CARBON R	RN72K1J-224JE	1	435032244R1	
PCB-U004	R4037	NF CARBON R	R25J-100	1	415471014T	
PCB-U004	R4038	NF CARBON R	R25J-100	1	415471014T	
PCB-U004	R41	C-CARBON R	RN72K1J-220JE	1	435032204R1	<MDC>
PCB-U004	R43	C-CARBON R	RN72K1J-000JE	1	435030004R1	<MDC>
PCB-U004	R4500	C-CARBON R	RN72K1J-224JE	1	435032244R1	
PCB-U004	R4501	C-CARBON R	RN72K1J-224JE	1	435032244R1	
PCB-U004	R4502	C-CARBON R	RN72K1J-224JE	1	435032244R1	
PCB-U004	R4503	C-CARBON R	RN72K1J-224JE	1	435032244R1	

PCB-U004	R4504	C-CARBON R	RN72K1J-224JE	1	435032244R1	
PCB-U004	R4505	C-CARBON R	RN72K1J-224JE	1	435032244R1	
PCB-U004	R4506	C-CARBON R	RN72K1J-224JE	1	435032244R1	
PCB-U004	R4507	C-CARBON R	RN72K1J-224JE	1	435032244R1	
PCB-U004	R4508	C-CARBON R	RN72K1J-224JE	1	435032244R1	
PCB-U004	R4509	C-CARBON R	RN72K1J-224JE	1	435032244R1	
PCB-U004	R4510	C-CARBON R	RN72K1J-224JE	1	435032244R1	
PCB-U004	R4511	C-CARBON R	RN72K1J-224JE	1	435032244R1	
PCB-U004	R4512	C-CARBON R	RN72K1J-224JE	1	435032244R1	
PCB-U004	R4513	C-CARBON R	RN72K1J-224JE	1	435032244R1	
PCB-U004	R4514	C-CARBON R	RN72K1J-224JE	1	435032244R1	
PCB-U004	R4515	C-CARBON R	RN72K1J-224JE	1	435032244R1	
PCB-U004	R4516	C-CARBON R	RN72K1J-224JE	1	435032244R1	
PCB-U004	R4517	C-CARBON R	RN72K1J-224JE	1	435032244R1	
PCB-U004	R4518	C-CARBON R	RN72K1J-224JE	1	435032244R1	
PCB-U004	R4519	C-CARBON R	RN72K1J-224JE	1	435032244R1	
PCB-U004	R4520	C-CARBON R	RN72K1J-224JE	1	435032244R1	
PCB-U004	R4521	C-CARBON R	RN72K1J-224JE	1	435032244R1	
PCB-U004	R4522	METAL O R	RS1/2WBJ-22	1	443522204T	
PCB-U004	R4523	METAL O R	RS1/2WBJ-22	1	443522204T	
PCB-U004	R49	C-CARBON R	RN72K1J-223JE	1	435032234R1	<MDC>
PCB-U004	R49	C-CARBON R	RN72K1J-223JE	1	435032234R1	<MMP, MMO>
PCB-U004	R4900	C-CARBON R	RN72K1J-224JE	1	435032244R1	
PCB-U004	R4901	C-CARBON R	RN72K1J-224JE	1	435032244R1	
PCB-U004	R4902	C-CARBON R	RN72K1J-224JE	1	435032244R1	<MDC>
PCB-U004	R4902	C-CARBON R	RN72K1J-224JE	1	435032244R1	<MMP, MMO>
PCB-U004	R4903	C-CARBON R	RN72K1J-224JE	1	435032244R1	<MDC>
PCB-U004	R4903	C-CARBON R	RN72K1J-224JE	1	435032244R1	<MMP, MMO>
PCB-U004	R4904	METAL R	RNU1/2WCJ-4.7	1	453530474T	
PCB-U004	R4905	METAL R	RNU1/2WCJ-4.7	1	453530474T	
PCB-U004	R4906	C-CARBON R	RN72K1J-471JE	1	435034714R1	
PCB-U004	R4907	C-CARBON R	RN72K1J-471JE	1	435034714R1	
PCB-U004	R4908	C-CARBON R	RN72K1J-472JE	1	435034724R1	

PCB-U004	R4909	C-CARBON R	RN72K1J-472JE	1	435034724R1	
PCB-U004	R4910	C-CARBON R	RN72K1J-103JE	1	435031034R1	
PCB-U004	R4911	C-CARBON R	RN72K1J-103JE	1	435031034R1	
PCB-U004	R4912	C-CARBON R	RN72K1J-471JE	1	435034714R1	<MDC>
PCB-U004	R4912	C-CARBON R	RN72K1J-471JE	1	435034714R1	<MMP, MMO>
PCB-U004	R4913	C-CARBON R	RN72K1J-471JE	1	435034714R1	<MDC>
PCB-U004	R4913	C-CARBON R	RN72K1J-471JE	1	435034714R1	<MMP, MMO>
PCB-U004	R4914	C-CARBON R	RN72K1J-472JE	1	435034724R1	<MDC>
PCB-U004	R4914	C-CARBON R	RN72K1J-472JE	1	435034724R1	<MMP, MMO>
PCB-U004	R4915	C-CARBON R	RN72K1J-472JE	1	435034724R1	<MDC>
PCB-U004	R4915	C-CARBON R	RN72K1J-472JE	1	435034724R1	<MMP, MMO>
PCB-U004	R4916	C-CARBON R	RN72K1J-103JE	1	435031034R1	<MDC>
PCB-U004	R4916	C-CARBON R	RN72K1J-103JE	1	435031034R1	<MMP, MMO>
PCB-U004	R4917	C-CARBON R	RN72K1J-103JE	1	435031034R1	<MDC>
PCB-U004	R4917	C-CARBON R	RN72K1J-103JE	1	435031034R1	<MMP, MMO>
PCB-U004	R4951	C-CARBON R	RN72K1J-224JE	1	435032244R1	<MDC>
PCB-U004	R4951	C-CARBON R	RN72K1J-224JE	1	435032244R1	<MMP, MMO>
PCB-U004	R4952	C-CARBON R	RN72K1J-224JE	1	435032244R1	<MDC>
PCB-U004	R4952	C-CARBON R	RN72K1J-224JE	1	435032244R1	<MMP, MMO>
PCB-U004	R4953	C-CARBON R	RN72K1J-224JE	1	435032244R1	<MDC>
PCB-U004	R4953	C-CARBON R	RN72K1J-224JE	1	435032244R1	<MMP, MMO>
PCB-U004	R4954	C-CARBON R	RN72K1J-224JE	1	435032244R1	<MDC>
PCB-U004	R4954	C-CARBON R	RN72K1J-224JE	1	435032244R1	<MMP, MMO>
PCB-U004	R4967	METAL O R	RS1/2WBJ-22	1	443522204T	<MDC>
PCB-U004	R4967	METAL O R	RS1/2WBJ-22	1	443522204T	<MMP, MMO>
PCB-U004	R4968	METAL O R	RS1/2WBJ-22	1	443522204T	<MDC>
PCB-U004	R4968	METAL O R	RS1/2WBJ-22	1	443522204T	<MMP, MMO>
PCB-U004	R4969	METAL O R	RS1/2WBJ-470	1	443524714T	
PCB-U004	R4970	METAL O R	RS1/2WBJ-470	1	443524714T	<MDC>
PCB-U004	R4970	METAL O R	RS1/2WBJ-470	1	443524714T	<MMP, MMO>
PCB-U004	R50	C-CARBON R	RN72K1J-223JE	1	435032234R1	<MDC>
PCB-U004	R50	C-CARBON R	RN72K1J-223JE	1	435032234R1	<MMP, MMO>
PCB-U004	R51	C-CARBON R	RN72K1J-223JE	1	435032234R1	<MDC>

PCB-U004	R51	C-CARBON R	RN72K1J-223JE	1	435032234R1	<MMP, MMO>
PCB-U004	R52	C-CARBON R	RN72K1J-223JE	1	435032234R1	<MDC>
PCB-U004	R52	C-CARBON R	RN72K1J-223JE	1	435032234R1	<MMP, MMO>
PCB-U004	R53	C-CARBON R	RN72K1J-223JE	1	435032234R1	<MDC>
PCB-U004	R53	C-CARBON R	RN72K1J-223JE	1	435032234R1	<MMP, MMO>
PCB-U004	R54	C-CARBON R	RN72K1J-223JE	1	435032234R1	<MDC>
PCB-U004	R54	C-CARBON R	RN72K1J-223JE	1	435032234R1	<MMP, MMO>
PCB-U004	R55	C-CARBON R	RN72K1J-223JE	1	435032234R1	<MDC>
PCB-U004	R55	C-CARBON R	RN72K1J-223JE	1	435032234R1	<MMP, MMO>
PCB-U004	R56	C-CARBON R	RN72K1J-223JE	1	435032234R1	<MDC>
PCB-U004	R56	C-CARBON R	RN72K1J-223JE	1	435032234R1	<MMP, MMO>
PCB-U004	R57	C-CARBON R	RN72K1J-103JE	1	435031034R1	<MDC>
PCB-U004	R58	C-CARBON R	RN72K1J-103JE	1	435031034R1	<MDC>
PCB-U004	R59	C-CARBON R	RN72K1J-103JE	1	435031034R1	<MDC>
PCB-U004	R60	C-CARBON R	RN72K1J-103JE	1	435031034R1	<MDC>
PCB-U004	R61	C-CARBON R	RN72K1J-103JE	1	435031034R1	<MDC>
PCB-U004	R62	C-CARBON R	RN72K1J-103JE	1	435031034R1	<MDC>
PCB-U004	R63	C-CARBON R	RN72K1J-103JE	1	435031034R1	<MDC>
PCB-U004	R64	C-CARBON R	RN72K1J-103JE	1	435031034R1	<MDC>
PCB-U004	R7001	C-CARBON R	RN72K1J-222JE	1	435032224R1	
PCB-U004	R7002	C-CARBON R	RN72K1J-000JE	1	435030004R1	
PCB-U004	R7003	C-CARBON R	RN72K1J-000JE	1	435030004R1	
PCB-U004	R7004	C-CARBON R	RN72K1J-102JE	1	435031024R1	
PCB-U004	R7005	C-CARBON R	RN72K1J-222JE	1	435032224R1	
PCB-U004	R7006	C-CARBON R	RN72K1J-101JE	1	435031014R1	
PCB-U004	R7007	C-CARBON R	RN72K1J-102JE	1	435031024R1	
PCB-U004	R7008	C-CARBON R	RN72K1J-103JE	1	435031034R1	<MDC>
PCB-U004	R7009	C-CARBON R	RN72K1J-224JE	1	435032244R1	
PCB-U004	R7010	C-CARBON R	RN72K1J-222JE	1	435032224R1	
PCB-U004	R7011	C-CARBON R	RN72K1J-103JE	1	435031034R1	
PCB-U004	R7012	C-CARBON R	RN72K1J-102JE	1	435031024R1	
PCB-U004	R7013	C-CARBON R	RN72K1J-103JE	1	435031034R1	
PCB-U004	R7014	C-CARBON R	RN72K1J-103JE	1	435031034R1	

PCB-U004	R7015	C-CARBON R	RN72K1J-103JE	1	435031034R1
PCB-U004	R7016	C-CARBON R	RN72K1J-103JE	1	435031034R1
PCB-U004	R7017	C-CARBON R	RN72K1J-103JE	1	435031034R1
PCB-U004	R7018	C-CARBON R	RN72K1J-103JE	1	435031034R1
PCB-U004	R7019	C-CARBON R	RN72K1J-103JE	1	435031034R1
PCB-U004	R7020	C-CARBON R	RN72K1J-103JE	1	435031034R1
PCB-U004	R7021	C-CARBON R	RN72K1J-273JE	1	435032734R1
PCB-U004	R7022	C-CARBON R	RN72K1J-103JE	1	435031034R1
PCB-U004	R7023	C-CARBON R	RN72K1J-103JE	1	435031034R1
PCB-U004	R7024	C-CARBON R	RN72K1J-103JE	1	435031034R1
PCB-U004	R7025	C-CARBON R	RN72K1J-470JE	1	435034704R1
PCB-U004	R7026	C-CARBON R	RN72K1J-470JE	1	435034704R1
PCB-U004	R7027	C-CARBON R	RN72K1J-470JE	1	435034704R1
PCB-U004	R7028	C-CARBON R	RN72K1J-470JE	1	435034704R1
PCB-U004	R7029	C-CARBON R	RN72K1J-103JE	1	435031034R1
PCB-U004	R7030	C-CARBON R	RN72K1J-103JE	1	435031034R1
PCB-U004	R7031	C-CARBON R	RN72K1J-222JE	1	435032224R1
PCB-U004	R7032	C-CARBON R	RN72K1J-101JE	1	435031014R1
PCB-U004	R7033	C-CARBON R	RN72K1J-470JE	1	435034704R1
PCB-U004	R7034	C-CARBON R	RN72K1J-470JE	1	435034704R1
PCB-U004	R7035	C-CARBON R	RN72K1J-470JE	1	435034704R1
PCB-U004	R7036	C-CARBON R	RN72K1J-221JE	1	435032214R1
PCB-U004	R7037	C-CARBON R	RN72K1J-470JE	1	435034704R1
PCB-U004	R7044	C-CARBON R	RN72K1J-221JE	1	435032214R1
PCB-U004	R7045	C-CARBON R	RN72K1J-221JE	1	435032214R1
PCB-U004	R7046	C-CARBON R	RN72K1J-470JE	1	435034704R1
PCB-U004	R7047	C-CARBON R	RN72K1J-470JE	1	435034704R1
PCB-U004	R7048	C-CARBON R	RN72K1J-470JE	1	435034704R1
PCB-U004	R7049	C-CARBON R	RN72K1J-470JE	1	435034704R1
PCB-U004	R7050	C-CARBON R	RN72K1J-470JE	1	435034704R1
PCB-U004	R7051	C-CARBON R	RN72K1J-470JE	1	435034704R1
PCB-U004	R7052	C-CARBON R	RN72K1J-470JE	1	435034704R1
PCB-U004	R7053	C-CARBON R	RN72K1J-470JE	1	435034704R1

PCB-U004	R7054	C-CARBON R	RN72K1J-470JE	1	435034704R1	
PCB-U004	R7055	C-CARBON R	RN72K1J-470JE	1	435034704R1	
PCB-U004	R7056	C-CARBON R	RN72K1J-470JE	1	435034704R1	
PCB-U004	R7057	C-CARBON R	RN72K1J-470JE	1	435034704R1	
PCB-U004	R7058	C-CARBON R	RN72K1J-221JE	1	435032214R1	
PCB-U004	R7059	C-CARBON R	RN72K1J-221JE	1	435032214R1	<MMP, MMO>
PCB-U004	R7060	C-CARBON R	RN72K1J-470JE	1	435034704R1	
PCB-U004	R7061	C-CARBON R	RN72K1J-272JE	1	435032724R1	
PCB-U004	R7062	C-CARBON R	RN72K1J-273JE	1	435032734R1	
PCB-U004	R7070	C-CARBON R	RN72K1J-103JE	1	435031034R1	
PCB-U004	R7071	C-CARBON R	RN72K1J-103JE	1	435031034R1	
PCB-U004	R7072	C-CARBON R	RN72K1J-103JE	1	435031034R1	
PCB-U004	R7074	C-CARBON R	RN72K1J-103JE	1	435031034R1	
PCB-U004	R7075	C-CARBON R	RN72K1J-103JE	1	435031034R1	
PCB-U004	R7076	C-CARBON R	RN72K1J-472JE	1	435034724R1	
PCB-U004	R7077	C-CARBON R	RN72K1J-103JE	1	435031034R1	
PCB-U004	R7078	C-CARBON R	RN72K1J-102JE	1	435031024R1	
PCB-U004	R7079	C-CARBON R	RN72K1J-103JE	1	435031034R1	
PCB-U004	R7080	C-CARBON R	RN72K1J-103JE	1	435031034R1	
PCB-U004	R7081	C-CARBON R	RN72K1J-103JE	1	435031034R1	
PCB-U004	R7082	C-CARBON R	RN72K1J-272JE	1	435032724R1	
PCB-U004	R7083	C-CARBON R	RN72K1J-272JE	1	435032724R1	
PCB-U004	R7084	C-CARBON R	RN72K1J-272JE	1	435032724R1	
PCB-U004	R7088	C-CARBON R	RN72K1J-221JE	1	435032214R1	
PCB-U004	R7089	C-CARBON R	RN72K1J-103JE	1	435031034R1	
PCB-U004	R7090	C-CARBON R	RN72K1J-470JE	1	435034704R1	
PCB-U004	R7091	C-CARBON R	RN72K1J-470JE	1	435034704R1	
PCB-U004	R7092	C-CARBON R	RN72K1J-470JE	1	435034704R1	
PCB-U004	R7093	C-CARBON R	RN72K1J-470JE	1	435034704R1	
PCB-U004	R7094	C-CARBON R	RN72K1J-470JE	1	435034704R1	
PCB-U004	R7095	C-CARBON R	RN72K1J-470JE	1	435034704R1	
PCB-U004	R7096	C-CARBON R	RN72K1J-102JE	1	435031024R1	
PCB-U004	R7097	C-CARBON R	RN72K1J-470JE	1	435034704R1	

PCB-U004	R7098	C-CARBON R	RN72K1J-470JE	1	435034704R1
PCB-U004	R7099	C-CARBON R	RN72K1J-222JE	1	435032224R1
PCB-U004	R7100	C-CARBON R	RN72K1J-470JE	1	435034704R1
PCB-U004	R7101	C-CARBON R	RN72K1J-221JE	1	435032214R1
PCB-U004	R7102	C-CARBON R	RN72K1J-470JE	1	435034704R1
PCB-U004	R7103	C-CARBON R	RN72K1J-221JE	1	435032214R1
PCB-U004	R7104	C-CARBON R	RN72K1J-470JE	1	435034704R1
PCB-U004	R7106	C-CARBON R	RN72K1J-470JE	1	435034704R1
PCB-U004	R7108	C-CARBON R	RN72K1J-470JE	1	435034704R1
PCB-U004	R7110	C-CARBON R	RN72K1J-470JE	1	435034704R1
PCB-U004	R7112	C-CARBON R	RN72K1J-470JE	1	435034704R1
PCB-U004	R7114	C-CARBON R	RN72K1J-470JE	1	435034704R1
PCB-U004	R7116	C-CARBON R	RN72K1J-470JE	1	435034704R1
PCB-U004	R7117	C-CARBON R	RN72K1J-470JE	1	435034704R1
PCB-U004	R7118	C-CARBON R	RN72K1J-470JE	1	435034704R1
PCB-U004	R7119	C-CARBON R	RN72K1J-470JE	1	435034704R1
PCB-U004	R7120	C-CARBON R	RN72K1J-470JE	1	435034704R1
PCB-U004	R7121	C-CARBON R	RN72K1J-470JE	1	435034704R1
PCB-U004	R7122	C-CARBON R	RN72K1J-103JE	1	435031034R1
PCB-U004	R7123	C-CARBON R	RN72K1J-473JE	1	435034734R1
PCB-U004	R7124	C-CARBON R	RN72K1J-102JE	1	435031024R1
PCB-U004	R7125	C-CARBON R	RN72K1J-000JE	1	435030004R1
PCB-U004	R7126	C-CARBON R	RN72K1J-470JE	1	435034704R1
PCB-U004	R7127	C-CARBON R	RN72K1J-000JE	1	435030004R1
PCB-U004	R7128	C-CARBON R	RN72K1J-221JE	1	435032214R1
PCB-U004	R7129	C-CARBON R	RN72K1J-470JE	1	435034704R1
PCB-U004	R7130	C-CARBON R	RN72K1J-221JE	1	435032214R1
PCB-U004	R7131	C-CARBON R	RN72K1J-221JE	1	435032214R1
PCB-U004	R7132	C-CARBON R	RN72K1J-221JE	1	435032214R1
PCB-U004	R7134	C-CARBON R	RN72K1J-221JE	1	435032214R1
PCB-U004	R7135	C-CARBON R	RN72K1J-470JE	1	435034704R1
PCB-U004	R7136	C-CARBON R	RN72K1J-103JE	1	435031034R1
PCB-U004	R7137	C-CARBON R	RN72K1J-221JE	1	435032214R1

PCB-U004	R7138	C-CARBON R	RN72K1J-470JE	1	435034704R1	
PCB-U004	R7140	C-CARBON R	RN72K1J-470JE	1	435034704R1	
PCB-U004	R7141	C-CARBON R	RN72K1J-470JE	1	435034704R1	
PCB-U004	R7143	C-CARBON R	RN72K1J-470JE	1	435034704R1	
PCB-U004	R7144	C-CARBON R	RN72K1J-221JE	1	435032214R1	
PCB-U004	R7145	C-CARBON R	RN72K1J-221JE	1	435032214R1	
PCB-U004	R7146	C-CARBON R	RN72K1J-103JE	1	435031034R1	
PCB-U004	R7147	C-CARBON R	RN72K1J-221JE	1	435032214R1	
PCB-U004	R7148	C-CARBON R	RN72K1J-470JE	1	435034704R1	
PCB-U004	R7149	C-CARBON R	RN72K1J-473JE	1	435034734R1	
PCB-U004	R7150	C-CARBON R	RN72K1J-221JE	1	435032214R1	
PCB-U004	R7151	C-CARBON R	RN72K1J-470JE	1	435034704R1	
PCB-U004	R7152	C-CARBON R	RN72K1J-221JE	1	435032214R1	
PCB-U004	R7153	C-CARBON R	RN72K1J-470JE	1	435034704R1	
PCB-U004	R7154	C-CARBON R	RN72K1J-333JE	1	435033334R1	<MDC>
PCB-U004	R7154	C-CARBON R	RN72K1J-333JE	1	435033334R1	<MMP, MMO>
PCB-U004	R7155	C-CARBON R	RN72K1J-103JE	1	435031034R1	<MDC>
PCB-U004	R7155	C-CARBON R	RN72K1J-103JE	1	435031034R1	<MMP, MMO>
PCB-U004	R7156	C-CARBON R	RN72K1J-470JE	1	435034704R1	
PCB-U004	R7157	C-CARBON R	RN72K1J-333JE	1	435033334R1	<MDC>
PCB-U004	R7157	C-CARBON R	RN72K1J-333JE	1	435033334R1	<MMP, MMO>
PCB-U004	R7158	C-CARBON R	RN72K1J-473JE	1	435034734R1	
PCB-U004	R7159	C-CARBON R	RN72K1J-103JE	1	435031034R1	<MDC>
PCB-U004	R7159	C-CARBON R	RN72K1J-103JE	1	435031034R1	<MMP, MMO>
PCB-U004	R7160	C-CARBON R	RN72K1J-221JE	1	435032214R1	
PCB-U004	R7162	C-CARBON R	RN72K1J-000JE	1	435030004R1	<MDC>
PCB-U004	R7162	C-CARBON R	RN72K1J-000JE	1	435030004R1	<MMP, MMO>
PCB-U004	R7163	C-CARBON R	RN72K1J-103JE	1	435031034R1	<MMP, MMO>
PCB-U004	R7163	C-CARBON R	RN72K1J-333JE	1	435033334R1	<MDC>
PCB-U004	R7164	C-CARBON R	RN72K1J-103JE	1	435031034R1	<MMP, MMO>
PCB-U004	R7164	C-CARBON R	RN72K1J-472JE	1	435034724R1	<MDC>
PCB-U004	R7165	C-CARBON R	RN72K1J-472JE	1	435034724R1	
PCB-U004	R7166	C-CARBON R	RN72K1J-472JE	1	435034724R1	



PCB-U004	R7167	C-CARBON R	RN72K1J-472JE	1	435034724R1	
PCB-U004	R7168	C-CARBON R	RN72K1J-472JE	1	435034724R1	
PCB-U004	R7169	C-CARBON R	RN72K1J-472JE	1	435034724R1	
PCB-U004	R7170	C-CARBON R	RN72K1J-472JE	1	435034724R1	
PCB-U004	R7171	C-CARBON R	RN72K1J-272JE	1	435032724R1	
PCB-U004	R7172	C-CARBON R	RN72K1J-272JE	1	435032724R1	
PCB-U004	R7173	C-CARBON R	RN72K1J-272JE	1	435032724R1	
PCB-U004	R7174	C-CARBON R	RN72K1J-272JE	1	435032724R1	
PCB-U004	R7175	C-CARBON R	RN72K1J-272JE	1	435032724R1	
PCB-U004	R7176	C-CARBON R	RN72K1J-272JE	1	435032724R1	
PCB-U004	R7177	C-CARBON R	RN72K1J-272JE	1	435032724R1	
PCB-U004	R7178	C-CARBON R	RN72K1J-272JE	1	435032724R1	
PCB-U004	R7180	C-CARBON R	RN72K1J-470JE	1	435034704R1	
PCB-U004	R7181	C-CARBON R	RN72K1J-102JE	1	435031024R1	
PCB-U004	R7182	C-CARBON R	RN72K1J-470JE	1	435034704R1	
PCB-U004	R7183	C-CARBON R	RN72K1J-000JE	1	435030004R1	
PCB-U004	R7184	C-CARBON R	RN72K1J-221JE	1	435032214R1	
PCB-U004	R7185	C-CARBON R	RN72K1J-221JE	1	435032214R1	
PCB-U004	R7186	C-CARBON R	RN72K1J-221JE	1	435032214R1	
PCB-U004	R7187	C-CARBON R	RN72K1J-221JE	1	435032214R1	
PCB-U004	R7188	C-CARBON R	RN72K1J-470JE	1	435034704R1	
PCB-U004	R7189	C-CARBON R	RN72K1J-470JE	1	435034704R1	
PCB-U004	R7190	C-CARBON R	RN72K1J-470JE	1	435034704R1	
PCB-U004	R7191	C-CARBON R	RN72K1J-470JE	1	435034704R1	
PCB-U004	R7192	C-CARBON R	RN72K1J-470JE	1	435034704R1	
PCB-U004	R7193	C-CARBON R	RN72K1J-470JE	1	435034704R1	
PCB-U004	R7194	C-CARBON R	RN72K1J-221JE	1	435032214R1	
PCB-U004	R7195	C-CARBON R	RN72K1J-000JE	1	435030004R1	
PCB-U004	R7196	C-CARBON R	RN72K1J-000JE	1	435030004R1	
PCB-U004	R7197	C-CARBON R	RN72K1J-221JE	1	435032214R1	<MMP, MMO>
PCB-U004	R7198	C-CARBON R	RN72K1J-470JE	1	435034704R1	
PCB-U004	R7199	C-CARBON R	RN72K1J-221JE	1	435032214R1	
PCB-U004	R7200	C-CARBON R	RN72K1J-103JE	1	435031034R1	

PCB-U004	R7202	C-CARBON R	RN72K1J-103JE	1	435031034R1	
PCB-U004	R7203	C-CARBON R	RN72K1J-103JE	1	435031034R1	
PCB-U004	R7204	C-CARBON R	RN72K1J-103JE	1	435031034R1	
PCB-U004	R7205	C-CARBON R	RN72K1J-103JE	1	435031034R1	
PCB-U004	R7206	C-CARBON R	RN72K1J-103JE	1	435031034R1	
PCB-U004	R7207	C-CARBON R	RN72K1J-103JE	1	435031034R1	
PCB-U004	R7208	C-CARBON R	RN72K1J-103JE	1	435031034R1	
PCB-U004	R7209	C-CARBON R	RN72K1J-103JE	1	435031034R1	
PCB-U004	R7210	C-CARBON R	RN72K1J-103JE	1	435031034R1	
PCB-U004	R7211	C-CARBON R	RN72K1J-103JE	1	435031034R1	
PCB-U004	R7212	C-CARBON R	RN72K1J-103JE	1	435031034R1	
PCB-U004	R7213	C-CARBON R	RN72K1J-473JE	1	435034734R1	
PCB-U004	R7214	C-CARBON R	RN72K1J-103JE	1	435031034R1	
PCB-U004	R7215	C-CARBON R	RN72K1J-224JE	1	435032244R1	
PCB-U004	R7216	C-CARBON R	RN72K1J-224JE	1	435032244R1	
PCB-U004	R7225	C-CARBON R	RN72K1J-103JE	1	435031034R1	
PCB-U004	R7228	C-CARBON R	RN72K1J-103JE	1	435031034R1	
PCB-U004	R7232	C-CARBON R	RN72K1J-473JE	1	435034734R1	
PCB-U004	R7233	C-CARBON R	RN72K1J-470JE	1	435034704R1	
PCB-U004	R7234	C-CARBON R	RN72K1J-103JE	1	435031034R1	<MDC>
PCB-U004	R7235	C-CARBON R	RN72K1J-103JE	1	435031034R1	
PCB-U004	R7237	C-CARBON R	RN72K1J-103JE	1	435031034R1	
PCB-U004	R7238	C-CARBON R	RN72K1J-562JE	1	435035624R1	<MDC>
PCB-U004	R7238	C-CARBON R	RN72K1J-562JE	1	435035624R1	<MMP, MMO>
PCB-U004	R7239	C-CARBON R	RN72K1J-470JE	1	435034704R1	
PCB-U004	R7240	C-CARBON R	RN72K1J-470JE	1	435034704R1	
PCB-U004	R7241	C-CARBON R	RN72K1J-470JE	1	435034704R1	
PCB-U004	R7242	C-CARBON R	RN72K1J-470JE	1	435034704R1	
PCB-U004	R7243	C-CARBON R	RN72K1J-221JE	1	435032214R1	
PCB-U004	R7244	C-CARBON R	RN72K1J-103JE	1	435031034R1	
PCB-U004	R7245	C-CARBON R	RN72K1J-103JE	1	435031034R1	
PCB-U004	R7246	C-CARBON R	RN72K1J-470JE	1	435034704R1	
PCB-U004	R7247	C-CARBON R	RN72K1J-470JE	1	435034704R1	

PCB-U004	R7248	C-CARBON R	RN72K1J-470JE	1	435034704R1	
PCB-U004	R7249	C-CARBON R	RN72K1J-103JE	1	435031034R1	
PCB-U004	R7251	C-CARBON R	RN72K1J-104JE	1	435031044R1	
PCB-U004	R7254	C-CARBON R	RN72K1J-104JE	1	435031044R1	
PCB-U004	R7255	C-CARBON R	RN72K1J-473JE	1	435034734R1	
PCB-U004	R7256	C-CARBON R	RN72K1J-473JE	1	435034734R1	
PCB-U004	R7257	C-CARBON R	RN72K1J-473JE	1	435034734R1	
PCB-U004	R7258	C-CARBON R	RN72K1J-473JE	1	435034734R1	
PCB-U004	R7259	C-CARBON R	RN72K1J-473JE	1	435034734R1	
PCB-U004	R7261	C-CARBON R	RN72K1J-473JE	1	435034734R1	
PCB-U004	R7262	C-CARBON R	RN72K1J-000JE	1	435030004R1	<MDC>
PCB-U004	R7262	C-CARBON R	RN72K1J-000JE	1	435030004R1	<MMP, MMO>
PCB-U004	R7264	METAL O R	RS1/2WBJ-10	1	443521004T	
PCB-U004	R7268	METAL R	RNU1/2WCJ-8.2	1	453530824T	
PCB-U004	R7269	METAL R	RNU1/2WCJ-8.2	1	453530824T	
PCB-U004	R7270	C-CARBON R	RN72K1J-470JE	1	435034704R1	
PCB-U004	R7273	C-CARBON R	RN72K1J-102JE	1	435031024R1	
PCB-U004	R7274	C-CARBON R	RN72K1J-222JE	1	435032224R1	
PCB-U004	R7275	C-CARBON R	RN72K1J-102JE	1	435031024R1	
PCB-U004	R7276	C-CARBON R	RN72K1J-222JE	1	435032224R1	
PCB-U004	R7285	C-CARBON R	RN72K1J-470JE	1	435034704R1	
PCB-U004	R7286	C-CARBON R	RN72K1J-221JE	1	435032214R1	
PCB-U004	R7289	C-CARBON R	RN72K1J-470JE	1	435034704R1	
PCB-U004	R7290	C-CARBON R	RN72K1J-470JE	1	435034704R1	
PCB-U004	R7291	C-CARBON R	RN72K1J-470JE	1	435034704R1	
PCB-U004	R7292	C-CARBON R	RN72K1J-470JE	1	435034704R1	
PCB-U004	R7293	C-CARBON R	RN72K1J-221JE	1	435032214R1	
PCB-U004	R7294	C-CARBON R	RN72K1J-103JE	1	435031034R1	
PCB-U004	R7295	C-CARBON R	RN72K1J-470JE	1	435034704R1	
PCB-U004	R7296	C-CARBON R	RN72K1J-470JE	1	435034704R1	
PCB-U004	R7297	C-CARBON R	RN72K1J-470JE	1	435034704R1	
PCB-U004	R7299	C-CARBON R	RN72K1J-221JE	1	435032214R1	
PCB-U004	R7300	METAL O R	RS1/2WBJ-10	1	443521004T	

PCB-U004	R7302	C-CARBON R	RN72K1J-470JE	1	435034704R1	<MDC>
PCB-U004	R7302	C-CARBON R	RN72K1J-470JE	1	435034704R1	<MMP, MMO>
PCB-U004	R7303	C-CARBON R	RN72K1J-470JE	1	435034704R1	<MDC>
PCB-U004	R7303	C-CARBON R	RN72K1J-470JE	1	435034704R1	<MMP, MMO>
PCB-U004	R7304	C-CARBON R	RN72K1J-100JE	1	435031004R1	<MDC>
PCB-U004	R7304	C-CARBON R	RN72K1J-100JE	1	435031004R1	<MMP, MMO>
PCB-U004	R7305	C-CARBON R	RN72K1J-000JE	1	435030004R1	<MDC>
PCB-U004	R7305	C-CARBON R	RN72K1J-000JE	1	435030004R1	<MMP, MMO>
PCB-U004	R7306	C-CARBON R	RN72K1J-000JE	1	435030004R1	<MDC>
PCB-U004	R7306	C-CARBON R	RN72K1J-000JE	1	435030004R1	<MMP, MMO>
PCB-U004	R7307	C-CARBON R	RN72K1J-273JE	1	435032734R1	
PCB-U004	R7308	C-CARBON R	RN72K1J-273JE	1	435032734R1	
PCB-U004	R7309	C-CARBON R	RN72K1J-273JE	1	435032734R1	
PCB-U004	R7311	C-CARBON R	RN72K1J-473JE	1	435034734R1	
PCB-U004	R7314	C-CARBON R	RN72K1J-273JE	1	435032734R1	<MDC>
PCB-U004	R7314	C-CARBON R	RN72K1J-273JE	1	435032734R1	<MMP, MMO>
PCB-U004	R7315	C-CARBON R	RN72K1J-823JE	1	435038234R1	<MDC>
PCB-U004	R7315	C-CARBON R	RN72K1J-823JE	1	435038234R1	<MMP, MMO>
PCB-U004	R7318	C-CARBON R	RN72K1J-102JE	1	435031024R1	
PCB-U004	<a href="#">[SW TRM]</a>					
PCB-U004	E1A	TRM	NTM-1P233(M1969)	1	25060302	
PCB-U004	E2	TRM-423(SCREW)	NEJITANSI ST3	1	25060495	
PCB-U004	JL3889A	WIRE HOL	NSCT-5P896	1	25051109	
PCB-U004	JL9501A	WIRE HOL	NSCT-7P898	1	25051111	
PCB-U004	P004	PWB	BCDG-0208	1	25140208D	N
PCB-U004	P005	PWB	BCCPU-0209	{ 1 }	25140209	N
PCB-U004	P006	PWB	BCAR-0210	{ 1 }	25140210	N
PCB-U004	P007	PWB	BCAF-0211	{ 1 }	25140211	N
PCB-U004	P008	PWB	BCACC-0212	{ 1 }	25140212	N
PCB-U004	P009	PWB	BCRF-0204	{ 1 }	25140204	N
PCB-U004	P011	PWB	BCETC-0246	{ 1 }	25140246	N
PCB-U004	P1010	PLUG	IMSA-9201B-1-06Z388-PT1	1	25056614	
PCB-U004	P103A	PLUG	NPLG-11P0966	1	25056016	

PCB-U004	P104A	PLUG	NPLG-7P0962	1	25056012	
PCB-U004	P105A	PLUG	NPLG-7P0962	1	25056012	
PCB-U004	P106B	SOCKET	NSCT-11P2104	1	25052207	<MDC>
PCB-U004	P106B	SOCKET	NSCT-11P2104	1	25052207	<MMP, MMO>
PCB-U004	P107A	PLUG	NPLG-11P0966	1	25056016	
PCB-U004	P2103B	SOCKET	IMSA-9142S-18A	1	25053231	
PCB-U004	P2104B	SOCKET	IMSA-9142S-20A	1	25053232	
PCB-U004	P3101A	PLUG	IMSA-9142B-26A	1	25056603	
PCB-U004	P3605B	SOCKET	IMSA-9142S-18A	1	25053231	
PCB-U004	P3606B	SOCKET	IMSA-9142S-8A	1	25053226	
PCB-U004	P3607B	SOCKET	IMSA-9142S-16A	1	25053230	
PCB-U004	P3608B	SOCKET	IMSA-9142S-18A	1	25053231	
PCB-U004	P3704	TRM-423(SCREW)	NEJITANSI ST3	1	25060495	
PCB-U004	P3705	TRM-423(SCREW)	NEJITANSI ST3	1	25060495	
PCB-U004	P3885A	PLUG	NPLG-11P0966	1	25056016	
PCB-U004	P3885B	SOCKET	NSCT-11P2191	1	25052294	
PCB-U004	P3886	PIN JACK	NPJ-3PDO656	1	25045884	<MDC>
PCB-U004	P3886 or	PIN JACK	NPJ-3PDO465	( 1)	25045666	<MDC>
PCB-U004	P3886	PIN JACK	NPJ-3PDO656	1	25045884	<MMP, MMO>
PCB-U004	P3886 or	PIN JACK	NPJ-3PDO465	( 1)	25045666	<MMP, MMO>
PCB-U004	P3887	SOCKET	MDS-09P-V-01(DSUB9P)	1	25053363	
PCB-U004	P3888	ST JACK	MSJ-035-22	1	25045887	
PCB-U004	P3888 or	JACK	YKB21-5130	( 1)	25045387	
PCB-U004	P4002B	SOCKET	NSCT-9P1024	1	25051234	
PCB-U004	P4003	TRM	NTM-1P233(M1969)	1	25060302	
PCB-U004	P4008B	SOCKET	NSCT-9P2102	1	25052205	N
PCB-U004	P4009B	SOCKET	NSCT-15P2108	1	25052211	
PCB-U004	P4020B	SOCKET	9210B-1-13Z140-PT1	1	25053364	N
PCB-U004	P4021B	SOCKET	9210B-1-13Z140-PT1	1	25053364	N
PCB-U004	P6851A	PLUG	IMSA-9142B-26A	1	25056603	
PCB-U004	P6853A	SOCKET	NSCT-9P2189	1	25052292	
PCB-U004	P7003B	SOCKET	IMSA-9618S-09A	1	25053334R2	
PCB-U004	P7009B	SOCKET	IMSA-9142S-18A	1	25053231	

PCB-U004	P7010B	SOCKET	IMSA-9142S-26A	1	25053235	
PCB-U004	P7012	TRM-423(SCREW)	NEJITANSI ST3	1	25060495	
PCB-U004	P7210B	PLUG	NPLG-11P358	1	25055375	<MDC>
PCB-U004	P7210B	PLUG	NPLG-11P358	1	25055375	<MMP, MMO>
PCB-U004	P7501A	PLUG	A2545WR2-2x20P(IDE40SIDE)	1	25056643	
PCB-U004	P8	SOCKET	2MJ-3516-002	1	25053355	<MDC>
PCB-U004	S3701	SLIDE SW	SSSS213000	1	25060497	
PCB-U005	<b>U0050</b>	DISPLAY PC BOARD (BADIS-0135-1B/ 1D)				
PCB-U005	<b>U0051</b>	LED PC BOARD (BASW-0136-1B/ 1D)				
PCB-U005	<b>U0052</b>	PHONE JACK PC BOARD (BAETC-0137-1B/ 1D)				
PCB-U005	<b>U0053</b>	FRONT OPT IN PC BOARD (BAETC-0138-1B/ 1D)				
PCB-U005	<b>U0054</b>	VOLUME PC BOARD (BAETC-0139-1B/ 1D)				
PCB-U005	<b>U0055</b>	DG POWER SUPPLY (SEC.) PC BOARD (BAPS-0140-1B/ 1D)				
PCB-U005	<b>U0056</b>	HOLDER PC BOARD (BAETC-0145-1B/ 1D)				
PCB-U005	<b>U0057</b>	HOLDER PC BOARD (BAETC-0142-1B/ 1D)				
PCB-U005	<b>U0058</b>	HOLDER PC BOARD (BAETC-0128-1B/ 1D)				
PCB-U005	<b>U0059</b>	HOLDER PC BOARD (BAETC-0144-1B/ 1D)				
PCB-U005	<b>U00510</b>	POWER SWITCH PC BOARD (BASW-0143-1F) <Note> MMP, MMO type only				
PCB-U005						
PCB-U005	<b>CIRCUIT. #</b>	<b>PART NAME</b>	<b>DESCRIPTION</b>	<b>Q'TY</b>	<b>PART NO. (SN)</b>	<b>REMARKS</b>
PCB-U005		<b>[TUNER UNIT]</b>				
PCB-U005	U7520	PHT CP	JSR1321-001	1	24120138	
PCB-U005	U7560	REMO SENS	TSOP34338RF1F	1	24130017	
PCB-U005		<b>[SEMI CONDUCTOR]</b>				
PCB-U005	D7500	ZENER D	UDZS10B	1	224551000R2	
PCB-U005	D7520	C-DIODE	1SS355	1	223269R2	
PCB-U005	D7520 or	C-DIODE	1SS352	(1)	223234R2	
PCB-U005	D7520 or	C-DIODE	MA2J111	(1)	223279R2	
PCB-U005	D7520 or	C-DIODE	KDS4148U	(1)	223283R2	
PCB-U005	D7521	C-DIODE	1SS355	1	223269R2	
PCB-U005	D7521 or	C-DIODE	1SS352	(1)	223234R2	
PCB-U005	D7521 or	C-DIODE	MA2J111	(1)	223279R2	

PCB-U005	D7521 or C-DIODE	KDS4148U	(1)	223283R2	
PCB-U005	D7522 C-DIODE	1SS355	1	223269R2	
PCB-U005	D7522 or C-DIODE	1SS352	(1)	223234R2	
PCB-U005	D7522 or C-DIODE	MA2J111	(1)	223279R2	
PCB-U005	D7522 or C-DIODE	KDS4148U	(1)	223283R2	
PCB-U005	D7523 C-DIODE	1SS355	1	223269R2	
PCB-U005	D7523 or C-DIODE	1SS352	(1)	223234R2	
PCB-U005	D7523 or C-DIODE	MA2J111	(1)	223279R2	
PCB-U005	D7523 or C-DIODE	KDS4148U	(1)	223283R2	
PCB-U005	D7530 ZENER D	UDZS5.1B	1	224550510R2	
PCB-U005	D7531 C-DIODE	1SS355	1	223269R2	
PCB-U005	D7531 or C-DIODE	1SS352	(1)	223234R2	
PCB-U005	D7531 or C-DIODE	MA2J111	(1)	223279R2	
PCB-U005	D7531 or C-DIODE	KDS4148U	(1)	223283R2	
PCB-U005	D7532 C-DIODE	1SS355	1	223269R2	
PCB-U005	D7532 or C-DIODE	1SS352	(1)	223234R2	
PCB-U005	D7532 or C-DIODE	MA2J111	(1)	223279R2	
PCB-U005	D7532 or C-DIODE	KDS4148U	(1)	223283R2	
PCB-U005	D7560 C-DIODE	1SS355	1	223269R2	
PCB-U005	D7560 or C-DIODE	1SS352	(1)	223234R2	
PCB-U005	D7560 or C-DIODE	MA2J111	(1)	223279R2	
PCB-U005	D7560 or C-DIODE	KDS4148U	(1)	223283R2	
PCB-U005	D7561 C-DIODE	1SS355	1	223269R2	
PCB-U005	D7561 or C-DIODE	1SS352	(1)	223234R2	
PCB-U005	D7561 or C-DIODE	MA2J111	(1)	223279R2	
PCB-U005	D7561 or C-DIODE	KDS4148U	(1)	223283R2	
PCB-U005	D7570 SPCF D	TSAL5300	1	225488	N
PCB-U005	D7580 C-DIODE	1SS355	1	223269R2	
PCB-U005	D7580 or C-DIODE	1SS352	(1)	223234R2	
PCB-U005	D7580 or C-DIODE	MA2J111	(1)	223279R2	
PCB-U005	D7580 or C-DIODE	KDS4148U	(1)	223283R2	
PCB-U005	D7581 C-DIODE	1SS355	1	223269R2	
PCB-U005	D7581 or C-DIODE	1SS352	(1)	223234R2	

PCB-U005	D7581 or	C-DIODE	MA2J111	(1)	223279R2	
PCB-U005	D7581 or	C-DIODE	KDS4148U	(1)	223283R2	
PCB-U005	D7582	C-DIODE	1SS355	1	223269R2	
PCB-U005	D7582 or	C-DIODE	1SS352	(1)	223234R2	
PCB-U005	D7582 or	C-DIODE	MA2J111	(1)	223279R2	
PCB-U005	D7582 or	C-DIODE	KDS4148U	(1)	223283R2	
PCB-U005	D7583	C-DIODE	1SS355	1	223269R2	
PCB-U005	D7583 or	C-DIODE	1SS352	(1)	223234R2	
PCB-U005	D7583 or	C-DIODE	MA2J111	(1)	223279R2	
PCB-U005	D7583 or	C-DIODE	KDS4148U	(1)	223283R2	
PCB-U005	D7585	LED	SCB3318E-D2	1	225487	
PCB-U005	D7591	LED	SCB3318E-D2	1	225487	<MDC>
PCB-U005	D7591	LED	SCB3318E-D2	1	225487	<MMP, MMO>
PCB-U005	D7592	LED	SLR-342MGTE7P	1	225455T	
PCB-U005	D7593	LED	SLR-342MGTE7P	1	225455T	
PCB-U005	D7595	LED	SLI-343URC-TE7	1	225449T	
PCB-U005	D9303	DIODE	D10XB60H	1	22380337F	<MDC>
PCB-U005	D9303	DIODE	D10XB60H	1	22380337F	<MMP, MMO>
PCB-U005	D9306	ZENER D	UDZS30B	1	224553000R2	
PCB-U005	D9310	ZENER D	UDZS16B	1	224551600R2	
PCB-U005	D9312	DIODE	RL1N4003	1	22380260T	
PCB-U005	D9313	DIODE	RL1N4003	1	22380260T	
PCB-U005	D9314	DIODE	RL1N4003	1	22380260T	
PCB-U005	D9315	DIODE	RL1N4003	1	22380260T	
PCB-U005	D9316	DIODE	RL1N4003	1	22380260T	
PCB-U005	D9350	C-DIODE	1SS355	1	223269R2	<MDC>
PCB-U005	D9350	C-DIODE	1SS355	1	223269R2	<MMP, MMO>
PCB-U005	D9351	C-DIODE	CRS09(TE85L_Q)	1	223274R2	<MDC>
PCB-U005	D9351	C-DIODE	CRS09(TE85L_Q)	1	223274R2	<MMP, MMO>
PCB-U005	Q7500	FL TUBE	HNA-16SL05T	1	212271A	
PCB-U005	Q7500A	HOLDER	(FL)	1	27191303	
PCB-U005	Q7501	IC	M66005-0001AHP	1	22242208R3	
PCB-U005	Q7502	IC	M66005-0001AHP	1	22242208R3	



PCB-U005	Q7503	TR	2SC2712-GR	1	2213145R2	
PCB-U005	Q7504	TR	2SC2712-GR	1	2213145R2	
PCB-U005	Q7530	IC	NJM4580M-D	1	22241448R2	
PCB-U005	Q7532	TR	RN1441	1	2215410R2	
PCB-U005	Q7533	TR	RN2403	1	2214540R2	
PCB-U005	Q7533 or	TR	KRA103S	( 1)	2216230R2	
PCB-U005	Q7534	IC	NJM4580M-D	1	22241448R2	
PCB-U005	Q7540	TR	DTA123JKA	1	2214090R2	
PCB-U005	Q7591	TR	DTC123JKA	1	2216690R2	<MDC>
PCB-U005	Q7591	TR	DTC123JKA	1	2216690R2	<MMP, MMO>
PCB-U005	Q7592	TR	DTC123JKA	1	2216690R2	
PCB-U005	Q7593	TR	DTC123JKA	1	2216690R2	
PCB-U005	Q7597	TR	DTC123JKA	1	2216690R2	
PCB-U005	Q7598	TR	DTC123JKA	1	2216690R2	
PCB-U005	Q9301	TR	2SC2235-Y(TPE6_F)	1	2211654T	
PCB-U005	Q9350	IC	SI8008TM	1	22242323R2	<MDC>
PCB-U005	Q9350	IC	SI8008TM	1	22242323R2	<MMP, MMO>
PCB-U005	<b>[TRANS COIL]</b>					
PCB-U005	L7520	CHOKE COIL	LBC2518T2R2M	1	231364M022R2	
PCB-U005	L7530	CHOKE COIL	LBC2518T2R2M	1	231364M022R2	
PCB-U005	L7580	CHOKE COIL	LBC2518T2R2M	1	231364M022R2	
PCB-U005	L7581	CHOKE COIL	LBC2518T2R2M	1	231364M022R2	
PCB-U005	L7582	CHOKE COIL	LBC2518T2R2M	1	231364M022R2	
PCB-U005	L9350	CHOKE COIL	NCH-2541	1	231363K470A	<MDC>
PCB-U005	L9350	CHOKE COIL	NCH-2541	1	231363K470A	<MMP, MMO>
PCB-U005	L9350 or	COIL	0182-7310-470K-RB	( 1)	231389	<MDC>
PCB-U005	L9350 or	COIL	0182-7310-470K-RB	( 1)	231389	<MMP, MMO>
PCB-U005	<b>[CAPACITOR]</b>					
PCB-U005	C7501	C-CERA C	CK725B1H-223K1	1	332102235R1	
PCB-U005	C7502	C-CERA C	CK725F1E-104Z1	1	332161040R1	
PCB-U005	C7503	C-CERA C	CK725F1E-104Z1	1	332161040R1	
PCB-U005	C7504	C-CERA C	CK725B1H-473K1	1	332104735R1	
PCB-U005	C7505	C-CERA C	CK725B1H-473K1	1	332104735R1	

PCB-U005	C7506	ELECT C	CE04W50V-33M	1	355783309T
PCB-U005	C7511	C-CERA C	CK725F1E-104Z1	1	332161040R1
PCB-U005	C7512	C-CERA C	CC725CH1H-180J1	1	342101804R1
PCB-U005	C7513	C-CERA C	CK725F1E-104Z1	1	332161040R1
PCB-U005	C7514	C-CERA C	CK725F1E-104Z1	1	332161040R1
PCB-U005	C7518	C-CERA C	CK725F1E-104Z1	1	332161040R1
PCB-U005	C7519	C-CERA C	CK725F1E-104Z1	1	332161040R1
PCB-U005	C7520	C-CERA C	CK725B1H-223K1	1	332102235R1
PCB-U005	C7521	UTSP C	CE04W10V-100M(UTSP)	1	397531017T
PCB-U005	C7522	C-CERA C	CC725CH1H-221J1	1	342102214R1
PCB-U005	C7523	C-CERA C	CC725CH1H-221J1	1	342102214R1
PCB-U005	C7524	C-CERA C	CK725B1H-102K1	1	332101025R1
PCB-U005	C7530	C-CERA C	CK725B1H-102K1	1	332101025R1
PCB-U005	C7531	C-CERA C	CK725B1H-102K1	1	332101025R1
PCB-U005	C7533	ELECT C	CE04W35V-47M	1	355764709T
PCB-U005	C7534	ELECT C	CE04W16V-47M	1	355744709T
PCB-U005	C7535	ELECT C	CE04W35V-10M(S)	1	353761009T
PCB-U005	C7536	C-CERA C	CC725CH1H-101J1	1	342101014R1
PCB-U005	C7537	C-CERA C	CC725CH1H-330J1	1	342103304R1
PCB-U005	C7538	ELECT C	CE04W35V-10M(S)	1	353761009T
PCB-U005	C7539	ELECT C	CE04W35V-10M(S)	1	353761009T
PCB-U005	C7540	ELECT C	CE04W35V-10M(S)	1	353761009T
PCB-U005	C7543	C-CERA C	CK725B1H-102K1	1	332101025R1
PCB-U005	C7560	ELECT C	CE04W6.3V-220M	1	355722219T
PCB-U005	C7561	C-CERA C	CK725B1H-102K1	1	332101025R1
PCB-U005	C7562	C-CERA C	CK725B1H-102K1	1	332101025R1
PCB-U005	C7580	MKT C	B32529C0102J289	1	376491024T
PCB-U005	C7581	MKT C	B32529C0102J289	1	376491024T
PCB-U005	C7582	MKT C	B32529C0102J289	1	376491024T
PCB-U005	C7583	MKT C	B32529C0102J289	1	376491024T
PCB-U005	C7590	C-CERA C	CK725B1H-103K1	1	332101035R1
PCB-U005	C7591	C-CERA C	CK725B1H-103K1	1	332101035R1
PCB-U005	C7900	C-CERA C	CK725F1E-104Z1	1	332161040R1

PCB-U005	C9302	VR C	CE04W16V-1000M(VR)	1	394641037S	<MDC>
PCB-U005	C9302	VR C	CE04W16V-1000M(VR)	1	394641037S	<MMP, MMO>
PCB-U005	C9304	VR C	CE04W63V-470M(VR)	1	394674717S	<MDC>
PCB-U005	C9304	VR C	CE04W63V-470M(VR)	1	394674717S	<MMP, MMO>
PCB-U005	C9305	VR C	CE04W63V-47M(VR)	1	394674707T	
PCB-U005	C9306	TF C	ECQ-V50V-223J	1	374722234T	
PCB-U005	C9307	TF C	ECQ-V50V-334J	1	374723344T	<MDC>
PCB-U005	C9307	TF C	ECQ-V50V-334J	1	374723344T	<MMP, MMO>
PCB-U005	C9350	VR C	CE04W16V-470M(VR)	1	394644717T	<MDC>
PCB-U005	C9350	VR C	CE04W16V-470M(VR)	1	394644717T	<MMP, MMO>
PCB-U005	C9351	VR C	CE04W6.3V-1000M(VR)	1	394621027T	<MDC>
PCB-U005	C9351	VR C	CE04W6.3V-1000M(VR)	1	394621027T	<MMP, MMO>
PCB-U005	<b>[RESISTOR]</b>					
PCB-U005	R7500	C-CARBON R	RN72K1J-221JE	1	435032214R1	
PCB-U005	R7501	C-CARBON R	RN72K1J-221JE	1	435032214R1	
PCB-U005	R7502	C-CARBON R	RN72K1J-273JE	1	435032734R1	
PCB-U005	R7503	C-CARBON R	RN72K1J-222JE	1	435032224R1	
PCB-U005	R7504	C-CARBON R	RN72K1J-222JE	1	435032224R1	
PCB-U005	R7505	C-CARBON R	RN72K1J-222JE	1	435032224R1	
PCB-U005	R7506	C-CARBON R	RN72K1J-222JE	1	435032224R1	
PCB-U005	R7507	C-CARBON R	RN72K1J-222JE	1	435032224R1	
PCB-U005	R7508	C-CARBON R	RN72K1J-222JE	1	435032224R1	
PCB-U005	R7509	C-CARBON R	RN72K1J-222JE	1	435032224R1	
PCB-U005	R7510	C-CARBON R	RN72K1J-222JE	1	435032224R1	
PCB-U005	R7520	C-CARBON R	RN72K1J-221JE	1	435032214R1	
PCB-U005	R7521	C-CARBON R	RN72K1J-331JE	1	435033314R1	
PCB-U005	R7522	C-CARBON R	RN72K1J-331JE	1	435033314R1	
PCB-U005	R7523	C-CARBON R	RN72K1J-750JE	1	435037504R1	
PCB-U005	R7526	C-CARBON R	RN72K1J-223JE	1	435032234R1	
PCB-U005	R7527	C-CARBON R	RN72K1J-223JE	1	435032234R1	
PCB-U005	R7528	C-CARBON R	RN72K1J-224JE	1	435032244R1	
PCB-U005	R7529	C-CARBON R	RN72K1J-224JE	1	435032244R1	
PCB-U005	R7530	C-CARBON R	RN72K1J-472JE	1	435034724R1	

PCB-U005	R7531	C-CARBON R	RN72K1J-101JE	1	435031014R1	
PCB-U005	R7532	C-CARBON R	RN72K1J-331JE	1	435033314R1	
PCB-U005	R7533	C-CARBON R	RN72K1J-182JE	1	435031824R1	
PCB-U005	R7534	C-CARBON R	RN72K1J-104JE	1	435031044R1	
PCB-U005	R7535	C-CARBON R	RN72K1J-102JE	1	435031024R1	
PCB-U005	R7536	C-CARBON R	RN72K1J-333JE	1	435033334R1	
PCB-U005	R7537	C-CARBON R	RN72K1J-333JE	1	435033334R1	
PCB-U005	R7538	C-CARBON R	RN72K1J-221JE	1	435032214R1	
PCB-U005	R7539	C-CARBON R	RN72K1J-221JE	1	435032214R1	
PCB-U005	R7540	C-CARBON R	RN72K1J-473JE	1	435034734R1	
PCB-U005	R7541	C-CARBON R	RN72K1J-180JE	1	435031804R1	
PCB-U005	R7560	C-CARBON R	RN72K1J-102JE	1	435031024R1	
PCB-U005	R7561	C-CARBON R	RN72K1J-101JE	1	435031014R1	
PCB-U005	R7562	C-CARBON R	RN72K1J-105JE	1	435031054R1	
PCB-U005	R7580	METAL O R	RS1WBJ-33	1	443623304T	
PCB-U005	R7581	METAL O R	RS1WBJ-33	1	443623304T	
PCB-U005	R7590	C-CARBON R	RN72K1J-103JE	1	435031034R1	
PCB-U005	R7591	C-CARBON R	RN72K1J-103JE	1	435031034R1	
PCB-U005	R7592	C-CARBON R	RN72K1J-103JE	1	435031034R1	
PCB-U005	R7593	C-CARBON R	RN72K1J-103JE	1	435031034R1	
PCB-U005	R7594	C-CARBON R	RN72K1J-121JE	1	435031214R1	
PCB-U005	R7595	C-CARBON R	RN72K1J-121JE	1	435031214R1	<MDC>
PCB-U005	R7595	C-CARBON R	RN72K1J-121JE	1	435031214R1	<MMP, MMO>
PCB-U005	R7596	C-CARBON R	RN72K1J-181JE	1	435031814R1	
PCB-U005	R7597	C-CARBON R	RN72K1J-181JE	1	435031814R1	
PCB-U005	R7599	C-CARBON R	RN72K1J-102JE	1	435031024R1	
PCB-U005	R7611	C-CARBON R	RN72K1J-271JE	1	435032714R1	
PCB-U005	R7612	C-CARBON R	RN72K1J-331JE	1	435033314R1	
PCB-U005	R7613	C-CARBON R	RN72K1J-471JE	1	435034714R1	
PCB-U005	R7614	C-CARBON R	RN72K1J-561JE	1	435035614R1	
PCB-U005	R7615	C-CARBON R	RN72K1J-821JE	1	435038214R1	
PCB-U005	R7616	C-CARBON R	RN72K1J-122JE	1	435031224R1	
PCB-U005	R7617	C-CARBON R	RN72K1J-222JE	1	435032224R1	

PCB-U005	R7618	C-CARBON R	RN72K1J-392JE	1	435033924R1
PCB-U005	R7619	C-CARBON R	RN72K1J-123JE	1	435031234R1
PCB-U005	R7621	C-CARBON R	RN72K1J-271JE	1	435032714R1
PCB-U005	R7622	C-CARBON R	RN72K1J-331JE	1	435033314R1
PCB-U005	R7623	C-CARBON R	RN72K1J-471JE	1	435034714R1
PCB-U005	R7624	C-CARBON R	RN72K1J-561JE	1	435035614R1
PCB-U005	R7625	C-CARBON R	RN72K1J-821JE	1	435038214R1
PCB-U005	R7626	C-CARBON R	RN72K1J-122JE	1	435031224R1
PCB-U005	R7627	C-CARBON R	RN72K1J-222JE	1	435032224R1
PCB-U005	R7628	C-CARBON R	RN72K1J-392JE	1	435033924R1
PCB-U005	R7629	C-CARBON R	RN72K1J-123JE	1	435031234R1
PCB-U005	R7631	C-CARBON R	RN72K1J-271JE	1	435032714R1
PCB-U005	R7632	C-CARBON R	RN72K1J-331JE	1	435033314R1
PCB-U005	R7633	C-CARBON R	RN72K1J-471JE	1	435034714R1
PCB-U005	R7634	C-CARBON R	RN72K1J-561JE	1	435035614R1
PCB-U005	R7635	C-CARBON R	RN72K1J-821JE	1	435038214R1
PCB-U005	R7636	C-CARBON R	RN72K1J-122JE	1	435031224R1
PCB-U005	R7637	C-CARBON R	RN72K1J-222JE	1	435032224R1
PCB-U005	R7638	C-CARBON R	RN72K1J-392JE	1	435033924R1
PCB-U005	R7639	C-CARBON R	RN72K1J-123JE	1	435031234R1
PCB-U005	R7641	C-CARBON R	RN72K1J-271JE	1	435032714R1
PCB-U005	R7642	C-CARBON R	RN72K1J-331JE	1	435033314R1
PCB-U005	R7643	C-CARBON R	RN72K1J-471JE	1	435034714R1
PCB-U005	R7644	C-CARBON R	RN72K1J-561JE	1	435035614R1
PCB-U005	R7645	C-CARBON R	RN72K1J-821JE	1	435038214R1
PCB-U005	R7646	C-CARBON R	RN72K1J-122JE	1	435031224R1
PCB-U005	R7647	C-CARBON R	RN72K1J-222JE	1	435032224R1
PCB-U005	R7648	C-CARBON R	RN72K1J-392JE	1	435033924R1
PCB-U005	R7649	C-CARBON R	RN72K1J-123JE	1	435031234R1
PCB-U005	R7802	C-CARBON R	RN72K1J-103JE	1	435031034R1
PCB-U005	R7939	C-CARBON R	RN72K1J-104JE	1	435031044R1
PCB-U005	R7954	C-CARBON R	RN72K1J-104JE	1	435031044R1
PCB-U005	R9304	METAL O R	RS1/2WBJ-10	1	443521004T

PCB-U005	R9305	C-CARBON R	RN72K1J-562JE	1	435035624R1	
PCB-U005	R9307	C-CARBON R	RN72K1J-333JE	1	435033334R1	
PCB-U005	R9308	METAL R	RNU1/2WCJ-0.1	1	453531094T	<MDC>
PCB-U005	R9308	METAL R	RNU1/2WCJ-0.1	1	453531094T	<MMP, MMO>
PCB-U005	R9310	METAL O R	RS1WBJ-27	1	443622704T	<MDC>
PCB-U005	R9310	METAL O R	RS1WBJ-27	1	443622704T	<MMP, MMO>
PCB-U005	R9350	METAL R	RNU1/2WCJ-0.22	1	453532294T	<MDC>
PCB-U005	R9350	METAL R	RNU1/2WCJ-0.22	1	453532294T	<MMP, MMO>
PCB-U005	R9351	C-CARBON R	RN72K1J-563JE	1	435035634R1	<MDC>
PCB-U005	R9351	C-CARBON R	RN72K1J-563JE	1	435035634R1	<MMP, MMO>
PCB-U005	R9352	C-CARBON R	RN72K1J-562JE	1	435035624R1	<MDC>
PCB-U005	R9352	C-CARBON R	RN72K1J-562JE	1	435035624R1	<MMP, MMO>
PCB-U005	R9353	C-CARBON R	RN72K1J-102JE	1	435031024R1	<MDC>
PCB-U005	R9353	C-CARBON R	RN72K1J-102JE	1	435031024R1	<MMP, MMO>
PCB-U005	R9354	C-CARBON R	RN72K1J-392JE	1	435033924R1	<MDC>
PCB-U005	R9354	C-CARBON R	RN72K1J-392JE	1	435033924R1	<MMP, MMO>
PCB-U005	[SW TRM]					
PCB-U005	E7580	TRM	NTM-1P233(M1969)	1	25060302	
PCB-U005	F9301A	FUSE HOL	NSCT-1P2031	1	25052133T	!, <MDC>
PCB-U005	F9301A	FUSE HOL	NSCT-1P2031	1	25052133T	!, <MMP, MMO>
PCB-U005	F9301B	FUSE HOL	NSCT-1P2031	1	25052133T	!, <MDC>
PCB-U005	F9301B	FUSE HOL	NSCT-1P2031	1	25052133T	!, <MMP, MMO>
PCB-U005	JL4103B	SOCKET	NSCT-5P97	1	25050269	
PCB-U005	JL7560A	WIRE HOL	NSCT-3P874	1	25051087	
PCB-U005	JL7560B	WIRE HOL	NSCT-3P874	1	25051087	
PCB-U005	JL9303A	WIRE HOL	NSCT-5P876	1	25051089	
PCB-U005	JL9303B	WIRE TRAP	NPLG-5P588	1	25055626	
PCB-U005	JL9501B	SOCKET	NSCT-7P99	1	25050271	<MDC>
PCB-U005	JL9501B	SOCKET	NSCT-7P99	1	25050271	<MMP, MMO>
PCB-U005	P7501B	PLUG	A2545WR2-2x20P(IDE40SIDE)	1	25056643	
PCB-U005	P7522	PIN JACK	NPJ-3PDB693	1	25045925	<MDC>
PCB-U005	P7522	PIN JACK	NPJ-3PDB693	1	25045925	<MMP, MMO>
PCB-U005	P7530	ST JACK	MSJ-035-05C B AG SR type	1	25045879	<MDC>

PCB-U005	P7530	ST JACK	MSJ-035-05C B AG SR type	1	25045879	<MMP, MMO>
PCB-U005	P7556	PWB	BCDIS-0135	1	25140135C	N
PCB-U005	P7557	PWB	BCSW-0136	{ 1 }	25140136	
PCB-U005	P7558	PWB	BCETC-0137	{ 1 }	25140137	
PCB-U005	P7559	PWB	BCETC-0138	{ 1 }	25140138	
PCB-U005	P7560	PWB	BCETC-0139	{ 1 }	25140139	
PCB-U005	P7561	PWB	BCPS-0140	{ 1 }	25140140	
PCB-U005	P7562	PWB	BCETC-0144	{ 1 }	25140144	<MMP, MMO>
PCB-U005	P7563	PWB	BCETC-0145	{ 1 }	25140145	
PCB-U005	P7565	PWB	BCETC-0142	{ 1 }	25140142	
PCB-U005	P7566	PWB	BCSW-0143	{ 1 }	25140143	<MMP, MMO>
PCB-U005	P7567	PWB	BCETC-0128	{ 1 }	25140128	
PCB-U005	P7580	ST JACK	MSJ-064-05A SR	1	25045783	<MDC>
PCB-U005	P7580	ST JACK	MSJ-064-05A SR	1	25045783	<MMP, MMO>
PCB-U005	P7590A	SOCKET AS	NSAS-18P1798	1	200AA391810UL	
PCB-U005	P7591A	SOCKET AS	NSAS-7P1799	1	200AA391415UL	
PCB-U005	P9008B	PLUG	NPLG-2P631	1	25055675	<MMP, MMO>
PCB-U005	P9301A	PLUG	NPLG-6P120	1	25055136	
PCB-U005	S7590	R ENCODE	EC12E2425WITH WASHER	1	25065655W	
PCB-U005	S7611	PUSH SW	NPS-111-S681	1	25035718T	
PCB-U005	S7612	PUSH SW	NPS-111-S681	1	25035718T	
PCB-U005	S7613	PUSH SW	NPS-111-S681	1	25035718T	
PCB-U005	S7614	PUSH SW	NPS-111-S681	1	25035718T	
PCB-U005	S7615	PUSH SW	NPS-111-S681	1	25035718T	<MDC>
PCB-U005	S7615	PUSH SW	NPS-111-S681	1	25035718T	<MMP, MMO>
PCB-U005	S7616	PUSH SW	NPS-111-S681	1	25035718T	
PCB-U005	S7618	PUSH SW	NPS-111-S681	1	25035718T	
PCB-U005	S7619	PUSH SW	NPS-111-S681	1	25035718T	
PCB-U005	S7620	PUSH SW	NPS-111-S681	1	25035718T	
PCB-U005	S7621	PUSH SW	NPS-111-S681	1	25035718T	
PCB-U005	S7622	PUSH SW	NPS-111-S681	1	25035718T	
PCB-U005	S7623	PUSH SW	NPS-111-S681	1	25035718T	
PCB-U005	S7624	PUSH SW	NPS-111-S681	1	25035718T	

PCB-U005	S7625	PUSH SW	NPS-111-S681	1	25035718T	
PCB-U005	S7626	PUSH SW	NPS-111-S681	1	25035718T	
PCB-U005	S7627	PUSH SW	NPS-111-S681	1	25035718T	
PCB-U005	S7628	PUSH SW	NPS-111-S681	1	25035718T	
PCB-U005	S7629	PUSH SW	NPS-111-S681	1	25035718T	
PCB-U005	S7630	PUSH SW	NPS-111-S681	1	25035718T	
PCB-U005	S7632	PUSH SW	NPS-111-S681	1	25035718T	
PCB-U005	S7633	PUSH SW	NPS-111-S681	1	25035718T	
PCB-U005	S7634	PUSH SW	NPS-111-S681	1	25035718T	
PCB-U005	S7635	PUSH SW	NPS-111-S681	1	25035718T	
PCB-U005	S7636	PUSH SW	NPS-111-S681	1	25035718T	
PCB-U005	S7637	PUSH SW	NPS-111-S681	1	25035718T	
PCB-U005	S7638	PUSH SW	NPS-111-S681	1	25035718T	
PCB-U005	S7639	PUSH SW	NPS-111-S681	1	25035718T	
PCB-U005	S7640	PUSH SW	NPS-111-S681	1	25035718T	
PCB-U005	S7641	PUSH SW	NPS-111-S681	1	25035718T	
PCB-U005	S7642	PUSH SW	NPS-111-S681	1	25035718T	
PCB-U005	S7643	PUSH SW	NPS-111-S681	1	25035718T	
PCB-U005	S7644	PUSH SW	NPS-111-S681	1	25035718T	
PCB-U005	S7645	PUSH SW	NPS-111-S681	1	25035718T	
PCB-U005	S7646	PUSH SW	NPS-111-S681	1	25035718T	
PCB-U005	S7647	PUSH SW	NPS-111-S681	1	25035718T	
PCB-U005	S7648	PUSH SW	NPS-111-S681	1	25035718T	
PCB-U005	S7649	PUSH SW	NPS-111-S681	1	25035718T	
PCB-U005	S7650	PUSH SW	NPS-111-S681	1	25035718T	
PCB-U005	S9000	P SW	NPS-111-L687P(TV-5)	1	25035724	<MMP, MMO>
PCB-U005	<b>[CHASSIS SCREW]</b>					
PCB-U005	D7570A	HOLDER	(LED)LH-5-5	1	27191312	
PCB-U005	D7591A	HOLDER	(LED)LH-5-5	1	27191312	<MDC>
PCB-U005	D7591A	HOLDER	(LED)LH-5-5	1	27191312	<MMP, MMO>
PCB-U006	<b>U0060</b>	SPEAKER TERMINAL PC BOARD (BATRM-0214-1D/ 1E)				
PCB-U006	<b>U0061</b>	SPEAKER TERMINAL (RH,SR) PC BOARD (BATRM-0215-1D/ 1E)				



- PCB-U006 **U0062** SPEAKER TERMINAL (CENTER) PC BOARD (BATRM-0216-1D/ 1E)
- PCB-U006 **U0063** POWER SUPPLY (PRI.) PC BOARD (BAPS-0217-1D/ 1E)
- PCB-U006 **U0064** INLET PC BOARD (BAPS-0218-1D/ 1E)
- PCB-U006 **U0065** REGULATOR PC BOARD (BAETC-0219-1D/ 1E)

PCB-U006	CIRCUIT. #	PART NAME	DESCRIPTION	Q'TY	PART NO. (SN)	REMARKS
PCB-U006		[SEMI CONDUCTOR]				
PCB-U006	D6800	DIODE	1SS133	1	223163T	
PCB-U006	D6801	DIODE	1SS133	1	223163T	
PCB-U006	D6802	DIODE	1SS133	1	223163T	
PCB-U006	D6803	DIODE	1SS133	1	223163T	
PCB-U006	D6804	DIODE	1SS133	1	223163T	
PCB-U006	D6805	DIODE	1SS133	1	223163T	
PCB-U006	D6806	DIODE	1SS133	1	223163T	
PCB-U006	D6807	DIODE	1SS133	1	223163T	
PCB-U006	D6808	DIODE	1SS133	1	223163T	
PCB-U006	D6809	DIODE	1SS133	1	223163T	
PCB-U006	D6810	DIODE	1SS133	1	223163T	
PCB-U006	D6811	DIODE	1SS133	1	223163T	
PCB-U006	D6812	DIODE	1SS133	1	223163T	
PCB-U006	D9000	DIODE	1SS133	1	223163T	
PCB-U006	D9001	DIODE	1SS133	1	223163T	
PCB-U006	D9002	DIODE	1SS133	1	223163T	
PCB-U006	D9003	DIODE	1SS133	1	223163T	
PCB-U006	D9004	DIODE	1SS133	1	223163T	
PCB-U006	D9005	DIODE	1SS133	1	223163T	
PCB-U006	D9006	DIODE	1SS133	1	223163T	
PCB-U006	D9007	ZENER D	MTZJ5.1B	1	224470512T	
PCB-U006	D9010	DIODE	1SS133	1	223163T	
PCB-U006	D9011	DIODE	1SS133	1	223163T	
PCB-U006	D9101	DIODE	1SS133	1	223163T	
PCB-U006	D9200	DIODE	1SS133	1	223163T	<MDC>
PCB-U006	D9200	DIODE	1SS133	1	223163T	<MMP, MMO>

PCB-U006	D9400	DIODE	D3SBA20	1	22380271F	
PCB-U006	D9410	DIODE	D3SBA20	1	22380271F	
PCB-U006	D9421	ZENER D	MTZJ13B	1	224471302T	N
PCB-U006	D9422	ZENER D	MTZJ13B	1	224471302T	N
PCB-U006	Q6801	TR	RN1226	1	2214680T	
PCB-U006	Q6802	TR	RN1226	1	2214680T	
PCB-U006	Q6803	TR	RN1226	1	2214680T	
PCB-U006	Q6804	TR	RN1226	1	2214680T	
PCB-U006	Q6805	TR	RN1226	1	2214680T	
PCB-U006	Q6806	TR	RN1226	1	2214680T	
PCB-U006	Q6807	TR	RN1226	1	2214680T	
PCB-U006	Q6900	TR	2SC2235-Y(TPE6_F)	1	2211654T	
PCB-U006	Q6901	TR	2SC2235-Y(TPE6_F)	1	2211654T	
PCB-U006	Q9101	TR	2SC1815-GR	1	2211255T	
PCB-U006	Q9200	TR	2SC1815-GR	1	2211255T	<MDC>
PCB-U006	Q9200	TR	2SC1815-GR	1	2211255T	<MMP, MMO>
PCB-U006	Q9410	IC	NJM2388F09	1	22242383	<MDC>
PCB-U006	Q9410	IC	NJM2388F09	1	22242383	<MMP, MMO>
PCB-U006	Q9423	TR	2SC1815-GR	1	2211255T	
PCB-U006	Q9424	TR	2SA1015-GR	1	2211455T	
PCB-U006	Q9425	TR	2SK365-GR	1	2212445T	
PCB-U006	Q9426	TR	2SK365-GR	1	2212445T	
PCB-U006	<b>[TRANS COIL]</b>					
PCB-U006	L6800	S COIL	SC-0.8X11.5X12.5T-6.5L	1	231393S	<MDC>
PCB-U006	L6800	S COIL	SC-0.8X11.5X12.5T-6.5L	1	231393S	<MMP, MMO>
PCB-U006	L6801	S COIL	SC-0.8X11.5X12.5T-6.5L	1	231393S	<MDC>
PCB-U006	L6801	S COIL	SC-0.8X11.5X12.5T-6.5L	1	231393S	<MMP, MMO>
PCB-U006	L6802	S COIL	SC-0.8X11.5X12.5T-6.5L	1	231393S	<MDC>
PCB-U006	L6802	S COIL	SC-0.8X11.5X12.5T-6.5L	1	231393S	<MMP, MMO>
PCB-U006	L6803	S COIL	SC-0.8X11.5X12.5T-6.5L	1	231393S	<MDC>
PCB-U006	L6803	S COIL	SC-0.8X11.5X12.5T-6.5L	1	231393S	<MMP, MMO>
PCB-U006	L6804	S COIL	SC-0.8X11.5X12.5T-6.5L	1	231393S	<MDC>
PCB-U006	L6804	S COIL	SC-0.8X11.5X12.5T-6.5L	1	231393S	<MMP, MMO>

PCB-U006	L6805	S COIL	SC-0.8X11.5X12.5T-6.5L	1	231393S	<MDC>
PCB-U006	L6805	S COIL	SC-0.8X11.5X12.5T-6.5L	1	231393S	<MMP, MMO>
PCB-U006	L6806	S COIL	SC-0.8X11.5X12.5T-6.5L	1	231393S	<MDC>
PCB-U006	L6806	S COIL	SC-0.8X11.5X12.5T-6.5L	1	231393S	<MMP, MMO>
PCB-U006	L6807	S COIL	SC-0.8X11.5X12.5T-6.5L	1	231393S	<MDC>
PCB-U006	L6807	S COIL	SC-0.8X11.5X12.5T-6.5L	1	231393S	<MMP, MMO>
PCB-U006	L6808	S COIL	SC-0.8X11.5X12.5T-6.5L	1	231393S	<MDC>
PCB-U006	L6808	S COIL	SC-0.8X11.5X12.5T-6.5L	1	231393S	<MMP, MMO>
PCB-U006	T9000	P TRANS	NPT-1520JQ	1	2301812A	!, <MDC>
PCB-U006	T9000	P TRANS	NPT-1520GQ	1	2301813A	!, <MMP, MMO>
PCB-U006	<b>[CAPACITOR]</b>					
PCB-U006	C5572	UTSP C	CE04W50V 47M(UTSP)	1	397584707T	
PCB-U006	C5573	UTSP C	CE04W50V 47M(UTSP)	1	397584707T	
PCB-U006	C5574	UTSP C	CE04W50V 47M(UTSP)	1	397584707T	
PCB-U006	C5575	UTSP C	CE04W50V 47M(UTSP)	1	397584707T	
PCB-U006	C5576	UTSP C	CE04W50V 47M(UTSP)	1	397584707T	
PCB-U006	C5579	UTSP C	CE04W50V 47M(UTSP)	1	397584707T	
PCB-U006	C6800	TF C	ECQ-V50V-103J	1	374721034T	
PCB-U006	C6801	TF C	ECQ-V50V-103J	1	374721034T	
PCB-U006	C6802	TF C	ECQ-V50V-103J	1	374721034T	
PCB-U006	C6803	TF C	ECQ-V50V-103J	1	374721034T	
PCB-U006	C6804	TF C	ECQ-V50V-103J	1	374721034T	
PCB-U006	C6805	TF C	ECQ-V50V-103J	1	374721034T	
PCB-U006	C6806	TF C	ECQ-V50V-103J	1	374721034T	
PCB-U006	C6807	TF C	ECQ-V50V-103J	1	374721034T	
PCB-U006	C6808	TF C	ECQ-V50V-103J	1	374721034T	
PCB-U006	C6809	TF C	ECQ-V50V-103J	1	374721034T	
PCB-U006	C6810	TF C	ECQ-V50V-103J	1	374721034T	
PCB-U006	C6811	TF C	ECQ-V50V-103J	1	374721034T	
PCB-U006	C6812	TF C	ECQ-V50V-103J	1	374721034T	
PCB-U006	C6830	MKT C	B32529C0102J289	1	376491024T	
PCB-U006	C6830 or	TF C	ECQ-B50V-102J	( 1)	374721024T	
PCB-U006	C6831	MKT C	B32529C0102J289	1	376491024T	

PCB-U006	C6831 or	TF C	ECQ-B50V-102J	(1)	374721024T
PCB-U006	C6832	MKT C	B32529C0102J289	1	376491024T
PCB-U006	C6832 or	TF C	ECQ-B50V-102J	(1)	374721024T
PCB-U006	C6833	MKT C	B32529C0102J289	1	376491024T
PCB-U006	C6833 or	TF C	ECQ-B50V-102J	(1)	374721024T
PCB-U006	C6834	MKT C	B32529C0102J289	1	376491024T
PCB-U006	C6834 or	TF C	ECQ-B50V-102J	(1)	374721024T
PCB-U006	C6835	MKT C	B32529C0102J289	1	376491024T
PCB-U006	C6835 or	TF C	ECQ-B50V-102J	(1)	374721024T
PCB-U006	C6836	MKT C	B32529C0102J289	1	376491024T
PCB-U006	C6836 or	TF C	ECQ-B50V-102J	(1)	374721024T
PCB-U006	C6837	MKT C	B32529C0102J289	1	376491024T
PCB-U006	C6837 or	TF C	ECQ-B50V-102J	(1)	374721024T
PCB-U006	C6838	MKT C	B32529C0102J289	1	376491024T
PCB-U006	C6838 or	TF C	ECQ-B50V-102J	(1)	374721024T
PCB-U006	C6839	MKT C	B32529C0102J289	1	376491024T
PCB-U006	C6839 or	TF C	ECQ-B50V-102J	(1)	374721024T
PCB-U006	C6840	MKT C	B32529C0102J289	1	376491024T
PCB-U006	C6840 or	TF C	ECQ-B50V-102J	(1)	374721024T
PCB-U006	C6850	TF C	ECQ-V50V-103J	1	374721034T
PCB-U006	C6851	TF C	ECQ-V50V-103J	1	374721034T
PCB-U006	C6852	TF C	ECQ-V50V-103J	1	374721034T
PCB-U006	C6853	TF C	ECQ-V50V-103J	1	374721034T
PCB-U006	C6854	TF C	ECQ-V50V-103J	1	374721034T
PCB-U006	C6855	TF C	ECQ-V50V-103J	1	374721034T
PCB-U006	C6856	TF C	ECQ-V50V-103J	1	374721034T
PCB-U006	C6857	TF C	ECQ-V50V-103J	1	374721034T
PCB-U006	C6858	TF C	ECQ-V50V-103J	1	374721034T
PCB-U006	C6859	TF C	ECQ-V50V-103J	1	374721034T
PCB-U006	C6860	TF C	ECQ-V50V-103J	1	374721034T
PCB-U006	C6870	TF C	ECQ-V50V-473J	1	374724734T
PCB-U006	C6871	TF C	ECQ-V50V-473J	1	374724734T
PCB-U006	C6872	TF C	ECQ-V50V-473J	1	374724734T

PCB-U006	C6873	TF C	ECQ-V50V-473J	1	374724734T	
PCB-U006	C6874	TF C	ECQ-V50V-473J	1	374724734T	
PCB-U006	C6875	TF C	ECQ-V50V-473J	1	374724734T	
PCB-U006	C6876	TF C	ECQ-V50V-473J	1	374724734T	
PCB-U006	C6877	TF C	ECQ-V50V-473J	1	374724734T	
PCB-U006	C6878	TF C	ECQ-V50V-473J	1	374724734T	
PCB-U006	C6900	VR C	CE04W16V-220M(VR)	1	394642217T	
PCB-U006	C6901	VR C	CE04W16V-220M(VR)	1	394642217T	
PCB-U006	C6902	UTSP C	CE04W50V-10M(UTSP)	1	397581007T	
PCB-U006	C6903	UTSP C	CE04W50V-10M(UTSP)	1	397581007T	
PCB-U006	C9000	TF C	ECQ-V50V-223J	1	374722234T	
PCB-U006	C9001	VR C	CE04W16V-2200M(VR)	1	394642227S	<MMP, MMO>
PCB-U006	C9001	VR C	CE04W25V-2200M(VR)	1	394652227S	<MDC>
PCB-U006	C9002	UTSP C	CE04W50V-4.7M(UTSP)	1	397580477T	
PCB-U006	C9008	VR C	CE04W16V-470M(VR)	1	394644717T	<MDC>
PCB-U006	C9008	VR C	CE04W16V-470M(VR)	1	394644717T	<MMP, MMO>
PCB-U006	C9108	PLA C	MKP R46 104M	1	3800041S	<MDC>
PCB-U006	C9108	PLA C	MKP R46 104M	1	3800041S	<MMP, MMO>
PCB-U006	C9116	TF C	ECQ-V50V-103J	1	374721034T	
PCB-U006	C9119	TF C	ECQ-V50V-223J	1	374722234T	
PCB-U006	C9201	TF C	ECQ-V50V-103J	1	374721034T	<MDC>
PCB-U006	C9201	TF C	ECQ-V50V-103J	1	374721034T	<MMP, MMO>
PCB-U006	C9400	TF C	ECQ-V50V-223J	1	374722234T	
PCB-U006	C9403	ELECT C	CE04W25V-4700M	1	354754726	N
PCB-U006	C9404	ELECT C	CE04W25V-4700M	1	354754726	N
PCB-U006	C9410	TF C	ECQ-V50V-104J	1	374721044T	
PCB-U006	C9411	VR C	CE04W16V-4700M(VR)	1	394644727S	
PCB-U006	C9412	UTSP C	CE04W50V-1M(UTSP)	1	397580107T	<MDC>
PCB-U006	C9412	UTSP C	CE04W50V-1M(UTSP)	1	397580107T	<MMP, MMO>
PCB-U006	C9413	UTSP C	CE04W25V-220M(UTSP)	1	397552217T	<MDC>
PCB-U006	C9413	UTSP C	CE04W25V-220M(UTSP)	1	397552217T	<MMP, MMO>
PCB-U006	C9421	UTSP C	CE04W25V-100M(UTSP)	1	397551017T	
PCB-U006	C9422	UTSP C	CE04W25V-100M(UTSP)	1	397551017T	

PCB-U006	C9423	UTSP C	CE04W25V-100M(UTSP)	1	397551017T	
PCB-U006	C9424	UTSP C	CE04W25V-100M(UTSP)	1	397551017T	
PCB-U006	D9008	DIODE	1SS133	1	223163T	
PCB-U006	D9009	DIODE	1SS133	1	223163T	
PCB-U006	<a href="#">[RESISTOR]</a>					
PCB-U006	R6800	CARBON R	R16J-22	1	417342204T	<MDC>
PCB-U006	R6800	CARBON R	R16J-22	1	417342204T	<MMP, MMO>
PCB-U006	R6801	CARBON R	R16J-22	1	417342204T	<MDC>
PCB-U006	R6801	CARBON R	R16J-22	1	417342204T	<MMP, MMO>
PCB-U006	R6802	CARBON R	R16J-22	1	417342204T	<MDC>
PCB-U006	R6802	CARBON R	R16J-22	1	417342204T	<MMP, MMO>
PCB-U006	R6803	CARBON R	R16J-22	1	417342204T	<MDC>
PCB-U006	R6803	CARBON R	R16J-22	1	417342204T	<MMP, MMO>
PCB-U006	R6804	CARBON R	R16J-22	1	417342204T	<MDC>
PCB-U006	R6804	CARBON R	R16J-22	1	417342204T	<MMP, MMO>
PCB-U006	R6805	CARBON R	R16J-22	1	417342204T	<MDC>
PCB-U006	R6805	CARBON R	R16J-22	1	417342204T	<MMP, MMO>
PCB-U006	R6806	CARBON R	R16J-22	1	417342204T	<MDC>
PCB-U006	R6806	CARBON R	R16J-22	1	417342204T	<MMP, MMO>
PCB-U006	R6807	CARBON R	R16J-22	1	417342204T	<MDC>
PCB-U006	R6807	CARBON R	R16J-22	1	417342204T	<MMP, MMO>
PCB-U006	R6808	CARBON R	R16J-22	1	417342204T	<MDC>
PCB-U006	R6808	CARBON R	R16J-22	1	417342204T	<MMP, MMO>
PCB-U006	R6810	CARBON R	R16J-22	1	417342204T	<MDC>
PCB-U006	R6810	CARBON R	R16J-22	1	417342204T	<MMP, MMO>
PCB-U006	R6811	CARBON R	R16J-22	1	417342204T	<MDC>
PCB-U006	R6811	CARBON R	R16J-22	1	417342204T	<MMP, MMO>
PCB-U006	R6812	CARBON R	R16J-22	1	417342204T	<MDC>
PCB-U006	R6812	CARBON R	R16J-22	1	417342204T	<MMP, MMO>
PCB-U006	R6813	CARBON R	R16J-22	1	417342204T	<MDC>
PCB-U006	R6813	CARBON R	R16J-22	1	417342204T	<MMP, MMO>
PCB-U006	R6814	CARBON R	R16J-22	1	417342204T	<MDC>
PCB-U006	R6814	CARBON R	R16J-22	1	417342204T	<MMP, MMO>

PCB-U006	R6815	CARBON R	R16J-22	1	417342204T	<MDC>
PCB-U006	R6815	CARBON R	R16J-22	1	417342204T	<MMP, MMO>
PCB-U006	R6816	CARBON R	R16J-22	1	417342204T	<MDC>
PCB-U006	R6816	CARBON R	R16J-22	1	417342204T	<MMP, MMO>
PCB-U006	R6817	CARBON R	R16J-22	1	417342204T	<MDC>
PCB-U006	R6817	CARBON R	R16J-22	1	417342204T	<MMP, MMO>
PCB-U006	R6818	CARBON R	R16J-22	1	417342204T	<MDC>
PCB-U006	R6818	CARBON R	R16J-22	1	417342204T	<MMP, MMO>
PCB-U006	R6820	METAL R	RNU1WCJ-8.2	1	453630824T	
PCB-U006	R6821	METAL R	RNU1WCJ-8.2	1	453630824T	
PCB-U006	R6822	METAL R	RNU1WCJ-8.2	1	453630824T	
PCB-U006	R6823	METAL R	RNU1WCJ-8.2	1	453630824T	
PCB-U006	R6824	METAL R	RNU1WCJ-8.2	1	453630824T	
PCB-U006	R6825	METAL R	RNU1WCJ-8.2	1	453630824T	
PCB-U006	R6826	METAL R	RNU1WCJ-8.2	1	453630824T	
PCB-U006	R6827	METAL R	RNU1WCJ-8.2	1	453630824T	
PCB-U006	R6828	METAL R	RNU1WCJ-8.2	1	453630824T	
PCB-U006	R6900	METAL O R	RS1/2WBJ-330	1	443523314T	
PCB-U006	R6901	METAL O R	RS1/2WBJ-330	1	443523314T	
PCB-U006	R9001	CARBON R	R16J-100K	1	417341044T	
PCB-U006	R9005	CARBON R	R16J-27	1	417342704T	<MDC>
PCB-U006	R9005	CARBON R	R16J-27	1	417342704T	<MMP, MMO>
PCB-U006	R9107	CARBON R	R16J-1K	1	417341024T	
PCB-U006	R9108	CARBON R	R16J-100K	1	417341044T	
PCB-U006	R9109	CARBON R	R16J-120	1	417341214T	<MMP, MMO>
PCB-U006	R9109	CARBON R	R16J-47	1	417344704T	<MDC>
PCB-U006	R9200	CARBON R	R16J-1K	1	417341024T	<MDC>
PCB-U006	R9200	CARBON R	R16J-1K	1	417341024T	<MMP, MMO>
PCB-U006	R9201	CARBON R	R16J-100K	1	417341044T	<MDC>
PCB-U006	R9201	CARBON R	R16J-100K	1	417341044T	<MMP, MMO>
PCB-U006	R9202	CARBON R	R16J-100	1	417341014T	<MDC>
PCB-U006	R9202	CARBON R	R16J-100	1	417341014T	<MMP, MMO>
PCB-U006	R9401	METAL PR	MPR2W+2WK 0R47	1	4000253	N

PCB-U006	R9402	METAL PR	MPR2W+2WK 0R47	1	4000253	N
PCB-U006	R9410	METAL R	RNU1/2WCJ-0.22	1	453532294T	
PCB-U006	R9421	METAL R	RNU1WCJ-0.22	1	453632294T	
PCB-U006	R9422	METAL R	RNU1WCJ-0.22	1	453632294T	
PCB-U006	R9427	CARBON R	R16J-330	1	417343314T	
PCB-U006	R9428	CARBON R	R16J-330	1	417343314T	
PCB-U006	R9429	CARBON R	R16J-10	1	417341004T	
PCB-U006	R9430	CARBON R	R16J-10	1	417341004T	
PCB-U006	R9431	CARBON R	R16J-10	1	417341004T	
PCB-U006	R9432	CARBON R	R16J-10	1	417341004T	
PCB-U006	<a href="#">[SW TRM]</a>					
PCB-U006	E6818	TRM-423(SCREW)	NEJITANSI ST3	1	25060495	
PCB-U006	E9100	TRM-423(SCREW)	NEJITANSI ST3	1	25060495	
PCB-U006	E9200A	TRM	NTM-1P233(M1969)	1	25060302	
PCB-U006	E9200B	TRM	NTM-1P232(M1700)	1	25060301	
PCB-U006	F9100A	FUSE HOL	SN5051	1	250113	!, <MDC>
PCB-U006	F9100A	FUSE HOL	NSCT-1P2031	1	25052133T	!, <MMP, MMO>
PCB-U006	F9100B	FUSE HOL	SN5051	1	250113	!, <MDC>
PCB-U006	F9100B	FUSE HOL	NSCT-1P2031	1	25052133T	!, <MMP, MMO>
PCB-U006	F9401A	FUSE HOL	NSCT-1P2031	1	25052133T	!
PCB-U006	F9401B	FUSE HOL	NSCT-1P2031	1	25052133T	!
PCB-U006	F9402A	FUSE HOL	NSCT-1P2031	1	25052133T	!
PCB-U006	F9402B	FUSE HOL	NSCT-1P2031	1	25052133T	!
PCB-U006	JL2601A	WIRE HOL	NSCT-5P876	1	25051089	
PCB-U006	JL4014A	WIRE HOL	NSCT-7P898	1	25051111	
PCB-U006	JL6808A	WIRE HOL	NSCT-5P896	1	25051109	
PCB-U006	JL6808B	SOCKET	NSCT-5P97	1	25050269	
PCB-U006	JL6809A	WIRE HOL	NSCT-9P900	1	25051113	
PCB-U006	JL6809B	SOCKET	NSCT-9P101	1	25050273	
PCB-U006	JL6900B	SOCKET	NSCT-3P108	1	25050280	
PCB-U006	JL6901A	WIRE HOL	NSCT-9P880	1	25051093	
PCB-U006	JL6901B	WIRE TRAP	NPLG-9P592	1	25055630	
PCB-U006	JL901A	WIRE HOL	NSCT-7P878	1	25051091	



PCB-U006	P001	PWB	BCTRM-0214	1	25140214C	N
PCB-U006	P002	PWB	BCTRM-0215	{ 1 }	25140215	N
PCB-U006	P003	PWB	BCTRM-0216	{ 1 }	25140216	N
PCB-U006	P004	PWB	BCPS-0217	{ 1 }	25140217	N
PCB-U006	P005	PWB	BCPS-0218	{ 1 }	25140218	N
PCB-U006	P006	PWB	BCETC-0219	{ 1 }	25140219	N
PCB-U006	P3101B	SOCKET	IMSA-9142S-26A	1	25053235	
PCB-U006	P6140H	PLUG	NPLG-9P165	1	25055181	
PCB-U006	P6240D	PLUG	NPLG-4P160	1	25055176	
PCB-U006	P6250E	PLUG	NPLG-5P161	1	25055177	
PCB-U006	P6800	TRM	NTM-2PDMCR400	1	25060472	<MDC>
PCB-U006	P6800	TRM	NTM-2PDMCR400	1	25060472	<MMP, MMO>
PCB-U006	P6801	TRM	NTM-2PDMCR400	1	25060472	<MDC>
PCB-U006	P6801	TRM	NTM-2PDMCR400	1	25060472	<MMP, MMO>
PCB-U006	P6802	TRM	NTM-2PDMCR400	1	25060472	<MDC>
PCB-U006	P6802	TRM	NTM-2PDMCR400	1	25060472	<MMP, MMO>
PCB-U006	P6803	TRM	NTM-2PDMCR400	1	25060472	<MDC>
PCB-U006	P6803	TRM	NTM-2PDMCR400	1	25060472	<MMP, MMO>
PCB-U006	P6804	TRM	NTM-2PDMCR400	1	25060472	<MDC>
PCB-U006	P6804	TRM	NTM-2PDMCR400	1	25060472	<MMP, MMO>
PCB-U006	P6805	TRM	NTM-2PDMCR400	1	25060472	<MDC>
PCB-U006	P6805	TRM	NTM-2PDMCR400	1	25060472	<MMP, MMO>
PCB-U006	P6806	TRM	NTM-2PDMCR400	1	25060472	<MDC>
PCB-U006	P6806	TRM	NTM-2PDMCR400	1	25060472	<MMP, MMO>
PCB-U006	P6807	TRM	NTM-2PDMCR400	1	25060472	<MDC>
PCB-U006	P6807	TRM	NTM-2PDMCR400	1	25060472	<MMP, MMO>
PCB-U006	P6808	TRM	NTM-2PDMCR400	1	25060472	<MDC>
PCB-U006	P6808	TRM	NTM-2PDMCR400	1	25060472	<MMP, MMO>
PCB-U006	P6809	TRM	NTM-2PDMCR400	1	25060472	<MDC>
PCB-U006	P6809	TRM	NTM-2PDMCR400	1	25060472	<MMP, MMO>
PCB-U006	P6810	TRM	NTM-2PDMCR400	1	25060472	<MDC>
PCB-U006	P6810	TRM	NTM-2PDMCR400	1	25060472	<MMP, MMO>
PCB-U006	P6851B	SOCKET	IMSA-9142S-26A	1	25053235	

PCB-U006	P6853B	PLUG	NPLG-9P0964	1	25056014	
PCB-U006	P6902B	PLUG	NPLG-9P356	1	25055373	
PCB-U006	P9000	AC INLET	NPLG-2P913	1	25055960	!, <MDC>
PCB-U006	P9000	AC INLET	NPLG-2P913	1	25055960	!, <MMP, MMO>
PCB-U006	P9006	CRIMP AS	CRIMP AS	1	206CC45159UL	!
PCB-U006	P9007	CRIMP AS	CRIMP AS	1	206CC45150UL	!
PCB-U006	P9008A	PLUG	NPLG-2P631	1	25055675	!, <MMP, MMO>
PCB-U006	P9100	PLUG	NPLG-2P632	1	25055676	!
PCB-U006	P9200	PLUG	NPLG-2P632	1	25055676	!, <MDC>
PCB-U006	P9200	PLUG	NPLG-2P632	1	25055676	!, <MMP, MMO>
PCB-U006	P9300	PLUG	NPLG-2P632	1	25055676	!, <MDC>
PCB-U006	P9300	PLUG	NPLG-2P632	1	25055676	!, <MMP, MMO>
PCB-U006	P9404	PLUG	NPLG-6P120	1	25055136	
PCB-U006	P9422A	SOCKET AS	NSAS-12P1700	1	200G3121210UL	
PCB-U006	P9422B	PLUG	NPLG-3P117	1	25055133	
PCB-U006	P9422C	PLUG	NPLG-3P117	1	25055133	
PCB-U006	RL6800	RELAY	NRL-2P5A-DC12-192	1	25065702	N
PCB-U006	RL6800 or	RELAY	NRL-2P5A-DC12-155	( 1)	25065607	
PCB-U006	RL6801	RELAY	NRL-2P5A-DC12-192	1	25065702	N
PCB-U006	RL6801 or	RELAY	NRL-2P5A-DC12-155	( 1)	25065607	
PCB-U006	RL6802	RELAY	NRL-2P5A-DC12-192	1	25065702	N
PCB-U006	RL6802 or	RELAY	NRL-2P5A-DC12-155	( 1)	25065607	
PCB-U006	RL6803	RELAY	NRL-2P5A-DC12-192	1	25065702	N
PCB-U006	RL6803 or	RELAY	NRL-2P5A-DC12-155	( 1)	25065607	
PCB-U006	RL6804	RELAY	NRL-2P5A-DC12-192	1	25065702	N
PCB-U006	RL6804 or	RELAY	NRL-2P5A-DC12-155	( 1)	25065607	
PCB-U006	RL6805	RELAY	NRL-2P5A-DC12-192	1	25065702	N
PCB-U006	RL6805 or	RELAY	NRL-2P5A-DC12-155	( 1)	25065607	
PCB-U006	RL6806	RELAY	NRL-2P5A-DC12-192	1	25065702	N
PCB-U006	RL6806 or	RELAY	NRL-2P5A-DC12-155	( 1)	25065607	
PCB-U006	RL6807	RELAY	NRL-2P5A-DC12-192	1	25065702	N
PCB-U006	RL6807 or	RELAY	NRL-2P5A-DC12-155	( 1)	25065607	
PCB-U006	RL6808	RELAY	NRL-2P5A-DC12-192	1	25065702	N

PCB-U006	RL6808 or RELAY	NRL-2P5A-DC12-155	(1)	25065607	
PCB-U006	RL6809 RELAY	NRL-2P5A-DC12-192	1	25065702	N
PCB-U006	RL6809 or RELAY	NRL-2P5A-DC12-155	(1)	25065607	
PCB-U006	RL6810 RELAY	NRL-2P5A-DC12-192	1	25065702	N
PCB-U006	RL6810 or RELAY	NRL-2P5A-DC12-155	(1)	25065607	
PCB-U006	RL6811 RELAY	NRL-2P5A-DC12-192	1	25065702	N
PCB-U006	RL6811 or RELAY	NRL-2P5A-DC12-155	(1)	25065607	
PCB-U006	RL6812 RELAY	NRL-2P5A-DC12-192	1	25065702	N
PCB-U006	RL6812 or RELAY	NRL-2P5A-DC12-155	(1)	25065607	
PCB-U006	RL9101 RELAY	NRL-1P10A-DC9-186	1	25065683	
PCB-U006	RL9102 RELAY	NRL-1P10A-DC9-186	1	25065683	!, <MDC>
PCB-U006	RL9200 RELAY	NRL-1P5A-DC9-179	1	25065669	!, <MDC>
PCB-U006	RL9200 RELAY	NRL-1P5A-DC9-179	1	25065669	!, <MMP, MMO>
PCB-U006	[ACCESSARY]				
PCB-U006	F9100C LABEL	T6.3AL/250V	1	29361681	<MMP, MMO>
PCB-U007	<b>U007</b> HDMI PC BOARD (BAHDM-0157-1A)				
PCB-U007					
PCB-U007	<b>CIRCUIT. PART NAME</b>	<b>DESCRIPTION</b>	<b>Q'TY</b>	<b>PART NO. (SN)</b>	<b>REMARKS</b>
PCB-U007	[SEMI CONDUCTOR]				
PCB-U007	D3101 C-DIODE	1SS352	1	223234R2	
PCB-U007	D3101 or C-DIODE	MA2J111	(1)	223279R2	
PCB-U007	D3101 or C-DIODE	KDS4148U	(1)	223283R2	
PCB-U007	D3401 C-DIODE	1SS352	1	223234R2	
PCB-U007	D3401 or C-DIODE	MA2J111	(1)	223279R2	
PCB-U007	D3401 or C-DIODE	KDS4148U	(1)	223283R2	
PCB-U007	D3501 C-DIODE	1SS352	1	223234R2	
PCB-U007	D3501 or C-DIODE	MA2J111	(1)	223279R2	
PCB-U007	D3501 or C-DIODE	KDS4148U	(1)	223283R2	
PCB-U007	D8301 C-DIODE	1SS226(TE85L_F)	1	223266R2	
PCB-U007	D8302 C-DIODE	1SS352	1	223234R2	
PCB-U007	D8302 or C-DIODE	MA2J111	(1)	223279R2	
PCB-U007	D8302 or C-DIODE	KDS4148U	(1)	223283R2	

PCB-U007	D8351	C-DIODE	1SS226(TE85L_F)	1	223266R2	
PCB-U007	D8352	C-DIODE	1SS352	1	223234R2	
PCB-U007	D8352 or	C-DIODE	MA2J111	(1)	223279R2	
PCB-U007	D8352 or	C-DIODE	KDS4148U	(1)	223283R2	
PCB-U007	D8652	C-DIODE	1SR154-400	1	22380284R2	
PCB-U007	D8653	C-DIODE	1SS352	1	223234R2	
PCB-U007	D8653 or	C-DIODE	MA2J111	(1)	223279R2	
PCB-U007	D8653 or	C-DIODE	KDS4148U	(1)	223283R2	
PCB-U007	D8701	C-DIODE	1SS352	1	223234R2	
PCB-U007	D8701 or	C-DIODE	MA2J111	(1)	223279R2	
PCB-U007	D8701 or	C-DIODE	KDS4148U	(1)	223283R2	
PCB-U007	D8801	C-DIODE	1SS352	1	223234R2	
PCB-U007	D8801 or	C-DIODE	MA2J111	(1)	223279R2	
PCB-U007	D8801 or	C-DIODE	KDS4148U	(1)	223283R2	
PCB-U007	D8951	DIODE	RSX501LA-20	1	22380364R2	N
PCB-U007	D8952	DIODE	RSX501LA-20	1	22380364R2	N
PCB-U007	D8953	DIODE	RSX501LA-20	1	22380364R2	N
PCB-U007	D8954	DIODE	RSX501LA-20	1	22380364R2	N
PCB-U007	D8958	C-DIODE	1SS352	1	223234R2	
PCB-U007	D8958 or	C-DIODE	MA2J111	(1)	223279R2	
PCB-U007	D8958 or	C-DIODE	KDS4148U	(1)	223283R2	
PCB-U007	Q205	IC	TC74VHC157FT	1	22274157ER2TO	
PCB-U007	Q3001	IC	D830K011AZKB300ZrevC	1	22242617R3	
PCB-U007	Q3002	IC (DSP)	NAND256W3A2BN6E (0323)	1	222W0092R303236	
PCB-U007	Q3003	IC	IS42S16160C-7TL	1	22242592R3	
PCB-U007	Q3003 or	IC	K4S561632J-UC75	(1)	22242524AR3	
PCB-U007	Q3004	IC	IS42S16160C-7TL	1	22242592R3	
PCB-U007	Q3004 or	IC	K4S561632J-UC75	(1)	22242524AR3	
PCB-U007	Q3005	IC	TC7W32FU	1	22241162R2	
PCB-U007	Q3006	IC	S-80127CNMC-JKM-T2	1	22241642R2	
PCB-U007	Q3102	IC	MIC2005-0.5YM6	1	22242590R2	
PCB-U007	Q3103	IC	BH18LB1WG-TR	1	22242562R2	
PCB-U007	Q3106	IC	BH33FB1WG-TR	1	22242585R2	

PCB-U007	Q3107	IC	TA48033BF(TE16L_NQ)	1	22278033DBR2TO	
PCB-U007	Q3108	IC	KSZ8041NL	1	22242591R2	
PCB-U007	Q3109	IC	BD7820	1	22242300R2	
PCB-U007	Q3202	IC	TC74VHC157FT	1	22274157ER2TO	
PCB-U007	Q3204	IC	TC7SZU04FU	1	22242512R2TO	
PCB-U007	Q3205	IC	TC7SZU04FU	1	22242512R2TO	
PCB-U007	Q3206	IC	NE5532APSR	1	22242283R2	
PCB-U007	Q3207	IC	NE5532APSR	1	22242283R2	
PCB-U007	Q3210	IC	TC7WH241FU(TE12L_F)	1	22242076R2TO	
PCB-U007	Q3401	IC (DSP 2nd)	ES29LV160ET-70TG (0325)	1	222W0069R303257	
PCB-U007	Q3401 or	IC (DSP 2nd)	S29AL016D70TFI010 (0325)	(1)	222W0063R303257	
PCB-U007	Q3401 or	IC (DSP 2nd)	S29AL016J70TFI010 (0325)	(1)	222W0100R303257	N
PCB-U007	Q3401 or	IC (DSP 2nd)	MX29LV160DTTI-7 (0325)	(1)	222W0104R303257	
PCB-U007	Q3402	IC	D788E001BRFP266Z	1	22242502R3	
PCB-U007	Q3403	IC	K4S641632K-UC60	1	22242462R2	
PCB-U007	Q3403 or	IC	K4S641632N-LC60	(1)	22242603R2	
PCB-U007	Q3403 or	IC	EM638165TS-7G	(1)	22242607R2	
PCB-U007	Q3404	IC	BD7820	1	22242300R2	
PCB-U007	Q3405	IC	TC7WU04FU(TE12L_F)	1	22240935R2	
PCB-U007	Q3406	IC	TA48033BF(TE16L_NQ)	1	22278033DBR2TO	
PCB-U007	Q3501	IC (DSP 3rd)	ES29LV160ET-70TG (0326)	1	222W0069R303268	
PCB-U007	Q3501 or	IC (DSP 3rd)	S29AL016D70TFI010 (0326)	(1)	222W0063R303268	
PCB-U007	Q3501 or	IC (DSP 3rd)	S29AL016J70TFI010 (0326)	(1)	222W0100R303268	N
PCB-U007	Q3501 or	IC (DSP 3rd)	MX29LV160DTTI-7 (0326)	(1)	222W0104R303268	
PCB-U007	Q3502	IC	D788E001BRFP266Z	1	22242502R3	
PCB-U007	Q3503	IC	K4S641632K-UC60	1	22242462R2	
PCB-U007	Q3503 or	IC	K4S641632N-LC60	(1)	22242603R2	
PCB-U007	Q3503 or	IC	EM638165TS-7G	(1)	22242607R2	
PCB-U007	Q3504	IC	BD7820	1	22242300R2	
PCB-U007	Q3604	IC	PCM1754DBQR	1	22242598R2	
PCB-U007	Q8001	IC	ADV7800BSTZ-150	1	22242606R3	N
PCB-U007	Q8002	IC	TA48018BF(TE16L_NQ)	1	22278018DBR2TO	
PCB-U007	Q8003	IC	K4S641632K-UC60	1	22242462R2	

PCB-U007	Q8003 or	IC	K4S641632N-LC60	( 1)	22242603R2	
PCB-U007	Q8161	IC	TA48018BF(TE16L_NQ)	1	22278018DBR2TO	
PCB-U007	Q8162	IC	SII9185ACTU	1	22242471R3	
PCB-U007	Q8305	IC	S-812C50BUC-C5ET2G	1	22242407R2	
PCB-U007	Q8306	IC	NC7SZ08P5X_F042	1	22242482R2	
PCB-U007	Q8306 or	IC	TC7SZ08FU(TE85L_F)	( 1)	22242071R2TO	
PCB-U007	Q8309	TR ARRAY	UM6K1N	1	226066R2	
PCB-U007	Q8355	IC	S-812C50BUC-C5ET2G	1	22242407R2	
PCB-U007	Q8356	IC	NC7SZ08P5X_F042	1	22242482R2	
PCB-U007	Q8356 or	IC	TC7SZ08FU(TE85L_F)	( 1)	22242071R2TO	
PCB-U007	Q8359	TR ARRAY	UM6K1N	1	226066R2	
PCB-U007	Q8362	IC	SII9185ACTU	1	22242471R3	
PCB-U007	Q8401	IC	SII9134CTU	1	22242394R3	
PCB-U007	Q8404	IC	BH18LB1WG-TR	1	22242562R2	
PCB-U007	Q8405	IC	SN74CB3Q3305PWR	1	22242258R2	
PCB-U007	Q8451	IC	SII9134CTU	1	22242394R3	
PCB-U007	Q8454	IC	BH18LB1WG-TR	1	22242562R2	
PCB-U007	Q8501	IC	SII9233ACTU	1	22242582R3	
PCB-U007	Q8595	IC	TA48018BF(TE16L_NQ)	1	22278018DBR2TO	
PCB-U007	Q8652	IC	BH33FB1WG-TR	1	22242585R2	
PCB-U007	Q8654	IC	BD7820	1	22242300R2	
PCB-U007	Q8701	IC (HDMI/VIDEO)	MPD70F3739GC-UEU-AX (0333)	1	222W0102R303335	
PCB-U007	Q8801	IC	ADV7342BSTZ-3	1	22242608R3	N
PCB-U007	Q8802	IC	BH18LB1WG-TR	1	22242562R2	
PCB-U007	Q8803	TR	DTC144EE	1	2216390R2	
PCB-U007	Q8803 or	TR	KRC404E	( 1)	2216450R2	
PCB-U007	Q8807	IC	TC7WZU04FU(TE12L_F)	1	22242078R2TO	
PCB-U007	Q8808	IC	TC74VCX162827	1	22242395R2	
PCB-U007	Q8809	IC	TC74VCX162827	1	22242395R2	
PCB-U007	Q8810	IC	TC74VCX162827	1	22242395R2	
PCB-U007	Q8811	IC	TC74VCX162827	1	22242395R2	
PCB-U007	Q8812	IC	TC74VCX162827	1	22242395R2	
PCB-U007	Q8813	IC	TC74VCX162827	1	22242395R2	

PCB-U007	Q8814	IC	TC74VCX162827	1	22242395R2
PCB-U007	Q8815	IC	TC74VCX162827	1	22242395R2
PCB-U007	Q8817	IC	TC74VCX162827	1	22242395R2
PCB-U007	Q8818	IC	TC74VCX162827	1	22242395R2
PCB-U007	Q8951	IC	MP1593DN	1	22242601R2
PCB-U007	Q8952	IC	MP1593DN	1	22242601R2
PCB-U007	Q8953	IC	MP1593DN	1	22242601R2
PCB-U007	Q8954	IC	MP1593DN	1	22242601R2
PCB-U007	Q8955	TR	DTC144EE	1	2216390R2
PCB-U007	Q8955 or	TR	KRC404E	(1)	2216450R2
PCB-U007	Q8956	TR	DTC144EE	1	2216390R2
PCB-U007	Q8956 or	TR	KRC404E	(1)	2216450R2
PCB-U007	Q8957	TR	DTC144EE	1	2216390R2
PCB-U007	Q8957 or	TR	KRC404E	(1)	2216450R2
PCB-U007	Q8958	TR	DTC144EE	1	2216390R2
PCB-U007	Q8958 or	TR	KRC404E	(1)	2216450R2
PCB-U007	U8001	IC	VX-50	1	22242392R3
PCB-U007	U8027	IC	HY5DU561622ETP-4-C	1	22242450R3
PCB-U007	U8027 or	IC	HY5DU561622FTP-4-C	(1)	22242577R3
PCB-U007	U8028	IC	HY5DU561622ETP-4-C	1	22242450R3
PCB-U007	U8028 or	IC	HY5DU561622FTP-4-C	(1)	22242577R3
PCB-U007	U8029	IC	HY5DU561622ETP-4-C	1	22242450R3
PCB-U007	U8029 or	IC	HY5DU561622FTP-4-C	(1)	22242577R3
PCB-U007	U8030	IC	HY5DU561622ETP-4-C	1	22242450R3
PCB-U007	U8030 or	IC	HY5DU561622FTP-4-C	(1)	22242577R3
PCB-U007	U8031	IC (VSP)	S29GL128P90TFIR20 (0338)	1	222W0090R30338A
PCB-U007	U8031 or	IC (VSP)	S29GL128N10TFI020 (0338)	(1)	222W0071R30338A
PCB-U007	U8067	IC	LP2996MX	1	22242438R2
PCB-U007	<b>[TRANS COIL]</b>				
PCB-U007	L251	CORE	BLM18PG181SN1D	1	2350005R1
PCB-U007	L261	EMIFIL	BK1608LM182-T	1	230958R1
PCB-U007	L3001	CORE	BLM18PG121SN1D	1	2350006R1
PCB-U007	L3002	CORE	BLM18PG121SN1D	1	2350006R1

PCB-U007	L3003	CORE	BLM18PG121SN1D	1	2350006R1
PCB-U007	L3004	CORE	BLM18PG121SN1D	1	2350006R1
PCB-U007	L3005	CORE	BLM18PG121SN1D	1	2350006R1
PCB-U007	L3102	CORE	BLM18PG181SN1D	1	2350005R1
PCB-U007	L3103	CORE	BLM18PG121SN1D	1	2350006R1
PCB-U007	L3104	CORE	BLM18PG121SN1D	1	2350006R1
PCB-U007	L3105	CORE	BLM18PG121SN1D	1	2350006R1
PCB-U007	L3106	CORE	BLM18PG121SN1D	1	2350006R1
PCB-U007	L3107	CORE	BLM18PG121SN1D	1	2350006R1
PCB-U007	L3108	CORE	BLM18PG121SN1D	1	2350006R1
PCB-U007	L3109	CORE	BLM18PG121SN1D	1	2350006R1
PCB-U007	L3110	CORE	BLM18PG121SN1D	1	2350006R1
PCB-U007	L3202	C-CARBON R	RN72K1J-000JE	1	435030004R1
PCB-U007	L3203	CORE	MMZ1608Y601BT	1	2350004R1
PCB-U007	L3204	EMIFIL	BK1608LM182-T	1	230958R1
PCB-U007	L3205	CORE	BLM18PG121SN1D	1	2350006R1
PCB-U007	L3206	CORE	BLM18PG121SN1D	1	2350006R1
PCB-U007	L3207	CORE	MMZ1608Y601BT	1	2350004R1
PCB-U007	L3208	CORE	MMZ1608Y601BT	1	2350004R1
PCB-U007	L3209	CORE	MMZ1608Y601BT	1	2350004R1
PCB-U007	L3401	C-CARBON R	RN72K1J-000JE	1	435030004R1
PCB-U007	L3402	CORE	BLM18PG121SN1D	1	2350006R1
PCB-U007	L3403	CORE	MMZ1608Y601BT	1	2350004R1
PCB-U007	L3405	CORE	BLM18PG121SN1D	1	2350006R1
PCB-U007	L3406	CORE	BLM18PG121SN1D	1	2350006R1
PCB-U007	L3407	CORE	BLM18PG121SN1D	1	2350006R1
PCB-U007	L3408	CORE	BLM18PG121SN1D	1	2350006R1
PCB-U007	L3409	CORE	BLM18PG121SN1D	1	2350006R1
PCB-U007	L3410	CORE	MMZ1608Y601BT	1	2350004R1
PCB-U007	L3411	CORE	MMZ1608Y601BT	1	2350004R1
PCB-U007	L3501	C-CARBON R	RN72K1J-000JE	1	435030004R1
PCB-U007	L3502	CORE	BLM18PG121SN1D	1	2350006R1
PCB-U007	L3503	CORE	MMZ1608Y601BT	1	2350004R1



PCB-U007	L3505	CORE	BLM18PG121SN1D	1	2350006R1
PCB-U007	L3506	CORE	BLM18PG121SN1D	1	2350006R1
PCB-U007	L3507	CORE	BLM18PG121SN1D	1	2350006R1
PCB-U007	L3508	CORE	BLM18PG121SN1D	1	2350006R1
PCB-U007	L3509	CHOKE COIL	LBC2518T470M	1	231364M470R2
PCB-U007	L8001	CHOKE COIL	LBC2518T2R2M	1	231364M022R2
PCB-U007	L8002	CHOKE COIL	LBC2518T2R2M	1	231364M022R2
PCB-U007	L8003	CHOKE COIL	LBC2518T2R2M	1	231364M022R2
PCB-U007	L8004	CHOKE COIL	LBC2518T2R2M	1	231364M022R2
PCB-U007	L8005	CHOKE COIL	LBC2518T2R2M	1	231364M022R2
PCB-U007	L8006	CHOKE COIL	LBC2518T2R2M	1	231364M022R2
PCB-U007	L8007	EMIFIL	BK1608LM182-T	1	230958R1
PCB-U007	L8008	EMIFIL	BK1608LM182-T	1	230958R1
PCB-U007	L8011	C-CARBON R	RN72K1J-000JE	1	435030004R1
PCB-U007	L8012	C-CARBON R	RN72K1J-000JE	1	435030004R1
PCB-U007	L8013	C-CARBON R	RN72K1J-000JE	1	435030004R1
PCB-U007	L8023	CHOKE COIL	BLM21PG221SN1	1	230949R2
PCB-U007	L8042	C-CARBON R	RN72K1J-000JE	1	435030004R1
PCB-U007	L8161	CORE	BLM18PG181SN1D	1	2350005R1
PCB-U007	L8162	CORE	BLM18PG181SN1D	1	2350005R1
PCB-U007	L8163	CORE	BLM18PG181SN1D	1	2350005R1
PCB-U007	L8361	CORE	BLM18PG181SN1D	1	2350005R1
PCB-U007	L8362	CORE	BLM18PG181SN1D	1	2350005R1
PCB-U007	L8363	CORE	BLM18PG181SN1D	1	2350005R1
PCB-U007	L8401	CORE	BLM18PG181SN1D	1	2350005R1
PCB-U007	L8402	CORE	BLM18PG181SN1D	1	2350005R1
PCB-U007	L8403	CORE	BLM18PG181SN1D	1	2350005R1
PCB-U007	L8404	CORE	BLM18PG181SN1D	1	2350005R1
PCB-U007	L8405	CORE	BLM18PG181SN1D	1	2350005R1
PCB-U007	L8406	C-R NET	MNR12E0APJ000	1	43464900002R2
PCB-U007	L8407	C-R NET	MNR12E0APJ000	1	43464900002R2
PCB-U007	L8408	CORE	BLM18PG181SN1D	1	2350005R1
PCB-U007	L8409	C-R NET	MNR12E0APJ000	1	43464900002R2

PCB-U007	L8410	C-R NET	MNR12E0APJ000	1	43464900002R2	
PCB-U007	L8450	C-R NET	MNR12E0APJ000	1	43464900002R2	
PCB-U007	L8451	CORE	BLM18PG181SN1D	1	2350005R1	
PCB-U007	L8452	CORE	BLM18PG181SN1D	1	2350005R1	
PCB-U007	L8453	CORE	BLM18PG181SN1D	1	2350005R1	
PCB-U007	L8454	CORE	BLM18PG181SN1D	1	2350005R1	
PCB-U007	L8455	CORE	BLM18PG181SN1D	1	2350005R1	
PCB-U007	L8456	C-R NET	MNR12E0APJ000	1	43464900002R2	
PCB-U007	L8457	C-R NET	MNR12E0APJ000	1	43464900002R2	
PCB-U007	L8458	CORE	BLM18PG181SN1D	1	2350005R1	
PCB-U007	L8459	C-R NET	MNR12E0APJ000	1	43464900002R2	
PCB-U007	L8601	CORE	BLM18PG181SN1D	1	2350005R1	
PCB-U007	L8602	CORE	BLM18PG181SN1D	1	2350005R1	
PCB-U007	L8603	CORE	BLM18PG181SN1D	1	2350005R1	
PCB-U007	L8604	CORE	BLM18PG181SN1D	1	2350005R1	
PCB-U007	L8605	CORE	BLM18PG181SN1D	1	2350005R1	
PCB-U007	L8606	CORE	BLM18PG181SN1D	1	2350005R1	
PCB-U007	L8608	CORE	MMZ1608Y601BT	1	2350004R1	
PCB-U007	L8641	CORE	BLM18PG181SN1D	1	2350005R1	
PCB-U007	L8701	CORE	BLM18PG181SN1D	1	2350005R1	
PCB-U007	L8801	CHOKE COIL	LBC2518T4R7M	1	231364M047R2	
PCB-U007	L8802	CHOKE COIL	LBC2518T4R7M	1	231364M047R2	
PCB-U007	L8803	CHOKE COIL	LBC2518T4R7M	1	231364M047R2	
PCB-U007	L8804	CHOKE COIL	LBC2518T4R7M	1	231364M047R2	
PCB-U007	L8806	CHOKE COIL	LBC2518T2R2M	1	231364M022R2	
PCB-U007	L8851	C-CARBON R	RN72K2B-000JE	1	433220004R1	
PCB-U007	L8852	C-CARBON R	RN72K2B-000JE	1	433220004R1	
PCB-U007	L8853	C-CARBON R	RN72K2B-000JE	1	433220004R1	
PCB-U007	L8854	C-CARBON R	RN72K2B-000JE	1	433220004R1	
PCB-U007	L8855	C-CARBON R	RN72K2B-000JE	1	433220004R1	
PCB-U007	L8856	C-CARBON R	RN72K2B-000JE	1	433220004R1	
PCB-U007	L8951	CHOKE COIL	0182-7E08Q-100M-RA	1	231396M100R2	N
PCB-U007	L8952	CHOKE COIL	0182-7E08Q-6R8N-RA	1	231395P068R2	N

PCB-U007	L8953	CHOKE COIL	0182-7E08Q-6R8N-RA	1	231395P068R2	N
PCB-U007	L8954	CHOKE COIL	0182-7E08Q-100M-RA	1	231396M100R2	N
PCB-U007	L8955	CHOKE COIL	BLM21PG221SN1	1	230949R2	
PCB-U007	L8956	CHOKE COIL	BLM21PG221SN1	1	230949R2	
PCB-U007	L8957	CHOKE COIL	BLM21PG221SN1	1	230949R2	
PCB-U007	L8958	CHOKE COIL	BLM21PG221SN1	1	230949R2	
PCB-U007	L8959	CHOKE COIL	BLM21PG221SN1	1	230949R2	
PCB-U007	L8960	CHOKE COIL	BLM21PG221SN1	1	230949R2	
PCB-U007	L8961	CHOKE COIL	BLM21PG221SN1	1	230949R2	
PCB-U007	L8962	CHOKE COIL	BLM21PG221SN1	1	230949R2	
PCB-U007	L8963	CHOKE COIL	BLM21PG221SN1	1	230949R2	
PCB-U007	L8964	CHOKE COIL	BLM21PG221SN1	1	230949R2	
PCB-U007	L8965	CHOKE COIL	BLM21PG221SN1	1	230949R2	
PCB-U007	L8966	CHOKE COIL	BLM21PG221SN1	1	230949R2	
PCB-U007	X3001	CRYSTAL	HC-49SMD24.000MHZ	1	3010479R2	N
PCB-U007	X3001 or	CRYSTAL	HC-49USSMD24.00MHZ	( 1)	3010471R2	
PCB-U007	X3201	CRYSTAL	HC-49/U03C 12.288MHZ	1	3010323R2	
PCB-U007	X3202	CRYSTAL	HC-49SMD11.2896MHZ	1	3010480R2	N
PCB-U007	X3202 or	CRYSTAL	HC-49USSMD11.2896MHZ	( 1)	3010472R2	
PCB-U007	X3401	CRYSTAL	HC-49USSMD17.734MHZ	1	3010442R2	
PCB-U007	X8001	CRYSTAL	DSX530GAK28.6363MHZ	1	3010475R2	N
PCB-U007	X8002	CRYSTAL	DSX530GAK27.0000MHZ	1	3010474R2	
PCB-U007	X8701	CERA LOCK	CSTCR5M00G53-B0	1	3010356R2	
PCB-U007	<b>[CAPACITOR]</b>					
PCB-U007	C251	C-CERA C	CK725F1A-105Z1	1	332181050R1	
PCB-U007	C252	C-CERA C	CK725F1A-105Z1	1	332181050R1	
PCB-U007	C3001	C-CERA C	CK725F1A-105Z1	1	332181050R1	
PCB-U007	C3002	C-CERA C	CK725F1A-105Z1	1	332181050R1	
PCB-U007	C3003	C-CERA C	CK725B0J-106K	1	332091065R2	
PCB-U007	C3004	C-CERA C	CK725B0J-106K	1	332091065R2	
PCB-U007	C3005	C-CERA C	CK725F1A-105Z1	1	332181050R1	
PCB-U007	C3006	C-CERA C	CC725CH1H-102J1	1	342101024R1	
PCB-U007	C3007	C-CERA C	CK725F1A-105Z1	1	332181050R1	

PCB-U007	C3008	C-CERA C	CC725CH1H-102J1	1	342101024R1
PCB-U007	C3009	C-CERA C	CK725F1A-105Z1	1	332181050R1
PCB-U007	C3010	C-CERA C	CK725F1A-105Z1	1	332181050R1
PCB-U007	C3011	C-CERA C	CK725F1A-105Z1	1	332181050R1
PCB-U007	C3012	C-CERA C	CC725CH1H-102J1	1	342101024R1
PCB-U007	C3013	C-CERA C	CK725F1A-105Z1	1	332181050R1
PCB-U007	C3014	C-CERA C	CC725CH1H-102J1	1	342101024R1
PCB-U007	C3015	C-CERA C	CC725CH1H-102J1	1	342101024R1
PCB-U007	C3016	C-CERA C	CK725F1A-105Z1	1	332181050R1
PCB-U007	C3017	C-CERA C	CK725F1A-105Z1	1	332181050R1
PCB-U007	C3018	C-CERA C	CK725F1A-105Z1	1	332181050R1
PCB-U007	C3019	C-CERA C	CC725CH1H-102J1	1	342101024R1
PCB-U007	C3020	C-CERA C	CK725F1A-105Z1	1	332181050R1
PCB-U007	C3021	C-CERA C	CK725F1A-105Z1	1	332181050R1
PCB-U007	C3022	C-CERA C	CK725F1A-105Z1	1	332181050R1
PCB-U007	C3023	C-CERA C	CK725B0J-106K	1	332091065R2
PCB-U007	C3024	C-CERA C	CC725CH1H-102J1	1	342101024R1
PCB-U007	C3025	C-CERA C	CK725F1A-105Z1	1	332181050R1
PCB-U007	C3026	C-CERA C	CK725B1C-104K1	1	332121045R1
PCB-U007	C3027	C-CERA C	CC725CH1H-102J1	1	342101024R1
PCB-U007	C3028	C-CERA C	CK725F1A-105Z1	1	332181050R1
PCB-U007	C3029	C-CERA C	CC725CH1H-102J1	1	342101024R1
PCB-U007	C3030	C-CERA C	CK725F1A-105Z1	1	332181050R1
PCB-U007	C3031	C-CERA C	CK725F1A-105Z1	1	332181050R1
PCB-U007	C3032	C-CERA C	CC725CH1H-102J1	1	342101024R1
PCB-U007	C3033	C-CERA C	CK725F1A-105Z1	1	332181050R1
PCB-U007	C3034	C-CERA C	CC725CH1H-120J1	1	342101204R1
PCB-U007	C3035	C-CERA C	CC725CH1H-102J1	1	342101024R1
PCB-U007	C3036	C-CERA C	CC725CH1H-120J1	1	342101204R1
PCB-U007	C3037	C-CERA C	CK725F1A-105Z1	1	332181050R1
PCB-U007	C3038	C-CERA C	CK725F1A-105Z1	1	332181050R1
PCB-U007	C3039	C-CERA C	CK725B1H-103K1	1	332101035R1
PCB-U007	C3040	C-CERA C	CK725F1A-105Z1	1	332181050R1

PCB-U007	C3041	C-CERA C	CK725B0J-106K	1	332091065R2
PCB-U007	C3042	C-CERA C	CK725F1A-105Z1	1	332181050R1
PCB-U007	C3043	C-CERA C	CK725F1A-105Z1	1	332181050R1
PCB-U007	C3101	CHIP ELECT C	CEWX16V-100M	1	398141017R2
PCB-U007	C3102	CHIP ELECT C	CEWX10V-220M	1	398132217R2
PCB-U007	C3103	C-CERA C	CC725CH1H-102J1	1	342101024R1
PCB-U007	C3104	C-CERA C	CK725F1A-105Z1	1	332181050R1
PCB-U007	C3105	C-CERA C	CK725F1A-105Z1	1	332181050R1
PCB-U007	C3106	C-CERA C	CK725B0J-106K	1	332091065R2
PCB-U007	C3107	C-CERA C	CK725F1A-105Z1	1	332181050R1
PCB-U007	C3108	C-CERA C	CK725F1A-105Z1	1	332181050R1
PCB-U007	C3109	C-CERA C	CK725B0J-106K	1	332091065R2
PCB-U007	C3110	C-CERA C	CK725B1A-224K1	1	332132245R1
PCB-U007	C3112	C-CERA C	CK725B0J-106K	1	332091065R2
PCB-U007	C3113	C-CERA C	CK725F1A-105Z1	1	332181050R1
PCB-U007	C3114	C-CERA C	CK725F1A-105Z1	1	332181050R1
PCB-U007	C3115	C-CERA C	CK725B0J-106K	1	332091065R2
PCB-U007	C3116	C-CERA C	CK725B0J-106K	1	332091065R2
PCB-U007	C3117	C-CERA C	CC725CH1H-102J1	1	342101024R1
PCB-U007	C3118	C-CERA C	CK725F1A-105Z1	1	332181050R1
PCB-U007	C3119	C-CERA C	CK725F1A-105Z1	1	332181050R1
PCB-U007	C3120	C-CERA C	CK725B0J-106K	1	332091065R2
PCB-U007	C3121	C-CERA C	CK725F1A-105Z1	1	332181050R1
PCB-U007	C3122	C-CERA C	CK725F1A-105Z1	1	332181050R1
PCB-U007	C3123	CHIP ELECT C	CEWX10V-220M	1	398132217R2
PCB-U007	C3124	C-CERA C	CK725F1A-105Z1	1	332181050R1
PCB-U007	C3125	C-CERA C	CK725B0J-106K	1	332091065R2
PCB-U007	C3126	C-CERA C	CK725B0J-106K	1	332091065R2
PCB-U007	C3127	C-CERA C	CK725F1A-105Z1	1	332181050R1
PCB-U007	C3128	C-CERA C	CK725F1A-105Z1	1	332181050R1
PCB-U007	C3129	C-CERA C	CK725F1A-105Z1	1	332181050R1
PCB-U007	C3130	C-CERA C	CK725B0J-106K	1	332091065R2
PCB-U007	C3131	C-CERA C	CK725F1A-105Z1	1	332181050R1

PCB-U007	C3132	C-CERA C	CC725CH1H-101J1	1	342101014R1
PCB-U007	C3133	C-CERA C	CK725F1A-105Z1	1	332181050R1
PCB-U007	C3134	C-CERA C	CK725B1C-104K1	1	332121045R1
PCB-U007	C3135	C-CERA C	CK725B1C-104K1	1	332121045R1
PCB-U007	C3136	C-CERA C	CK725F1A-105Z1	1	332181050R1
PCB-U007	C3137	C-CERA C	CK725F1A-105Z1	1	332181050R1
PCB-U007	C3138	C-CERA C	CK725F1A-105Z1	1	332181050R1
PCB-U007	C3139	C-CERA C	CK725F1A-105Z1	1	332181050R1
PCB-U007	C3140	C-CERA C	CK725F1A-105Z1	1	332181050R1
PCB-U007	C3143	C-CERA C	CK725F1A-105Z1	1	332181050R1
PCB-U007	C3144	C-CERA C	CK725F1A-105Z1	1	332181050R1
PCB-U007	C3145	C-CERA C	CK725B0J-106K	1	332091065R2
PCB-U007	C3146	C-CERA C	CK725F1A-105Z1	1	332181050R1
PCB-U007	C3147	C-CERA C	CK725B0J-106K	1	332091065R2
PCB-U007	C3148	C-CERA C	CK725B1H-223K1	1	332102235R1
PCB-U007	C3149	C-CERA C	CK725F1A-105Z1	1	332181050R1
PCB-U007	C3150	CHIP ELECT C	CEWX4V-22M	1	3981G2207R2
PCB-U007	C3151	C-CERA C	CK725B1H-103K1	1	332101035R1
PCB-U007	C3152	C-CERA C	CK725B0J-106K	1	332091065R2
PCB-U007	C3153	C-CERA C	CK725F1A-105Z1	1	332181050R1
PCB-U007	C3154	C-CERA C	CK725B0J-106K	1	332091065R2
PCB-U007	C3155	C-CERA C	CK725F1A-105Z1	1	332181050R1
PCB-U007	C3156	C-CERA C	CC725CH1H-102J1	1	342101024R1
PCB-U007	C3157	C-CERA C	CK725F1A-105Z1	1	332181050R1
PCB-U007	C3158	C-CERA C	CK725F1A-105Z1	1	332181050R1
PCB-U007	C3159	C-CERA C	CK725F1A-105Z1	1	332181050R1
PCB-U007	C3202	C-CERA C	CK725F1A-105Z1	1	332181050R1
PCB-U007	C3204	C-CERA C	CK725B0J-106K	1	332091065R2
PCB-U007	C3205	C-CERA C	CK725F1A-105Z1	1	332181050R1
PCB-U007	C3206	C-CERA C	CK725F1A-105Z1	1	332181050R1
PCB-U007	C3207	C-CERA C	CK725B0J-106K	1	332091065R2
PCB-U007	C3208	C-CERA C	CK725F1A-105Z1	1	332181050R1
PCB-U007	C3209	C-CERA C	CK725F1A-105Z1	1	332181050R1

PCB-U007	C3210	CHIP ELECT C	CEWX16V-100M	1	398141017R2
PCB-U007	C3211	C-CERA C	CK725B1H-222K1	1	332102225R1
PCB-U007	C3213	C-CERA C	CK725F1A-105Z1	1	332181050R1
PCB-U007	C3214	C-CERA C	CK725B0J-106K	1	332091065R2
PCB-U007	C3215	CHIP ELECT C	CEWX16V-10M	1	398141007R2
PCB-U007	C3216	C-CERA C	CC725CH1H-120J1	1	342101204R1
PCB-U007	C3219	C-CERA C	CC725CH1H-120J1	1	342101204R1
PCB-U007	C3220	C-CERA C	CC725CH1H-120J1	1	342101204R1
PCB-U007	C3223	C-CERA C	CC725CH1H-120J1	1	342101204R1
PCB-U007	C3224	C-CERA C	CK725B1H-152K1	1	332101525R1
PCB-U007	C3225	C-CERA C	CK725B1H-152K1	1	332101525R1
PCB-U007	C3226	C-CERA C	CK725F1A-105Z1	1	332181050R1
PCB-U007	C3227	CHIP ELECT C	CEWX16V-10M	1	398141007R2
PCB-U007	C3228	C-CERA C	CK725B1H-222K1	1	332102225R1
PCB-U007	C3229	C-CERA C	CK725F1A-105Z1	1	332181050R1
PCB-U007	C3230	C-CERA C	CK725B0J-106K	1	332091065R2
PCB-U007	C3231	C-CERA C	CK725F1A-105Z1	1	332181050R1
PCB-U007	C3233	CHIP ELECT C	CEWX16V-100M	1	398141017R2
PCB-U007	C3402	C-CERA C	CK725F1A-105Z1	1	332181050R1
PCB-U007	C3403	C-CERA C	CK725F1A-105Z1	1	332181050R1
PCB-U007	C3404	C-CERA C	CK725F1A-105Z1	1	332181050R1
PCB-U007	C3405	C-CERA C	CK725F1A-105Z1	1	332181050R1
PCB-U007	C3406	C-CERA C	CK725F1A-105Z1	1	332181050R1
PCB-U007	C3407	C-CERA C	CK725F1A-105Z1	1	332181050R1
PCB-U007	C3408	C-CERA C	CK725F1A-105Z1	1	332181050R1
PCB-U007	C3409	C-CERA C	CK725F1A-105Z1	1	332181050R1
PCB-U007	C3410	C-CERA C	CK725F1A-105Z1	1	332181050R1
PCB-U007	C3412	C-CERA C	CK725F1A-105Z1	1	332181050R1
PCB-U007	C3413	C-CERA C	CK725F1A-105Z1	1	332181050R1
PCB-U007	C3414	C-CERA C	CC725CH1H-102J1	1	342101024R1
PCB-U007	C3415	C-CERA C	CK725F1A-105Z1	1	332181050R1
PCB-U007	C3416	C-CERA C	CK725F1A-105Z1	1	332181050R1
PCB-U007	C3417	C-CERA C	CK725F1A-105Z1	1	332181050R1

PCB-U007	C3418	C-CERA C	CK725F1A-105Z1	1	332181050R1
PCB-U007	C3419	C-CERA C	CK725F1A-105Z1	1	332181050R1
PCB-U007	C3420	C-CERA C	CK725B0J-106K	1	332091065R2
PCB-U007	C3421	C-CERA C	CK725F1A-105Z1	1	332181050R1
PCB-U007	C3422	C-CERA C	CK725F1A-105Z1	1	332181050R1
PCB-U007	C3423	C-CERA C	CK725F1A-105Z1	1	332181050R1
PCB-U007	C3424	C-CERA C	CK725F1A-105Z1	1	332181050R1
PCB-U007	C3425	C-CERA C	CK725F1A-105Z1	1	332181050R1
PCB-U007	C3426	C-CERA C	CK725F1A-105Z1	1	332181050R1
PCB-U007	C3427	C-CERA C	CK725F1A-105Z1	1	332181050R1
PCB-U007	C3428	C-CERA C	CK725F1A-105Z1	1	332181050R1
PCB-U007	C3429	C-CERA C	CK725F1A-105Z1	1	332181050R1
PCB-U007	C3430	C-CERA C	CK725F1A-105Z1	1	332181050R1
PCB-U007	C3431	C-CERA C	CK725F1A-105Z1	1	332181050R1
PCB-U007	C3432	C-CERA C	CK725F1A-105Z1	1	332181050R1
PCB-U007	C3433	C-CERA C	CK725F1A-105Z1	1	332181050R1
PCB-U007	C3434	C-CERA C	CK725F1A-105Z1	1	332181050R1
PCB-U007	C3435	C-CERA C	CK725F1A-105Z1	1	332181050R1
PCB-U007	C3436	C-CERA C	CK725F1A-105Z1	1	332181050R1
PCB-U007	C3437	C-CERA C	CK725F1A-105Z1	1	332181050R1
PCB-U007	C3438	C-CERA C	CK725F1A-105Z1	1	332181050R1
PCB-U007	C3439	C-CERA C	CK725F1A-105Z1	1	332181050R1
PCB-U007	C3440	C-CERA C	CK725F1A-105Z1	1	332181050R1
PCB-U007	C3441	C-CERA C	CK725F1A-105Z1	1	332181050R1
PCB-U007	C3442	C-CERA C	CK725B0J-106K	1	332091065R2
PCB-U007	C3443	C-CERA C	CK725F1A-105Z1	1	332181050R1
PCB-U007	C3444	C-CERA C	CC725CH1H-102J1	1	342101024R1
PCB-U007	C3445	C-CERA C	CK725F1A-105Z1	1	332181050R1
PCB-U007	C3446	C-CERA C	CK725B0J-106K	1	332091065R2
PCB-U007	C3447	C-CERA C	CK725B0J-106K	1	332091065R2
PCB-U007	C3448	C-CERA C	CK725B0J-106K	1	332091065R2
PCB-U007	C3449	C-CERA C	CK725F1A-105Z1	1	332181050R1
PCB-U007	C3450	C-CERA C	CK725F1A-105Z1	1	332181050R1



PCB-U007	C3451	C-CERA C	CK725F1A-105Z1	1	332181050R1
PCB-U007	C3452	C-CERA C	CK725F1A-105Z1	1	332181050R1
PCB-U007	C3453	CHIP ELECT C	CEWX4V-22M	1	3981G2207R2
PCB-U007	C3454	C-CERA C	CK725B1H-103K1	1	332101035R1
PCB-U007	C3455	C-CERA C	CK725F1A-105Z1	1	332181050R1
PCB-U007	C3456	C-CERA C	CK725B0J-106K	1	332091065R2
PCB-U007	C3457	C-CERA C	CK725F1A-105Z1	1	332181050R1
PCB-U007	C3458	C-CERA C	CK725B0J-106K	1	332091065R2
PCB-U007	C3459	C-CERA C	CK725F1A-105Z1	1	332181050R1
PCB-U007	C3461	CHIP ELECT C	CEWX4V-220M	1	3981G2217R2
PCB-U007	C3462	C-CERA C	CK725F1A-105Z1	1	332181050R1
PCB-U007	C3463	C-CERA C	CC725CH1H-060D1	1	342100602R1
PCB-U007	C3464	C-CERA C	CC725CH1H-060D1	1	342100602R1
PCB-U007	C3502	C-CERA C	CK725F1A-105Z1	1	332181050R1
PCB-U007	C3503	C-CERA C	CK725F1A-105Z1	1	332181050R1
PCB-U007	C3504	C-CERA C	CK725F1A-105Z1	1	332181050R1
PCB-U007	C3505	C-CERA C	CK725F1A-105Z1	1	332181050R1
PCB-U007	C3506	C-CERA C	CK725F1A-105Z1	1	332181050R1
PCB-U007	C3507	C-CERA C	CK725F1A-105Z1	1	332181050R1
PCB-U007	C3508	C-CERA C	CK725F1A-105Z1	1	332181050R1
PCB-U007	C3509	C-CERA C	CK725F1A-105Z1	1	332181050R1
PCB-U007	C3510	C-CERA C	CK725F1A-105Z1	1	332181050R1
PCB-U007	C3512	C-CERA C	CK725F1A-105Z1	1	332181050R1
PCB-U007	C3513	C-CERA C	CK725F1A-105Z1	1	332181050R1
PCB-U007	C3514	C-CERA C	CC725CH1H-101J1	1	342101014R1
PCB-U007	C3515	C-CERA C	CK725F1A-105Z1	1	332181050R1
PCB-U007	C3516	C-CERA C	CK725F1A-105Z1	1	332181050R1
PCB-U007	C3517	C-CERA C	CK725F1A-105Z1	1	332181050R1
PCB-U007	C3518	C-CERA C	CK725F1A-105Z1	1	332181050R1
PCB-U007	C3519	C-CERA C	CK725F1A-105Z1	1	332181050R1
PCB-U007	C3520	C-CERA C	CK725B0J-106K	1	332091065R2
PCB-U007	C3521	C-CERA C	CK725F1A-105Z1	1	332181050R1
PCB-U007	C3522	C-CERA C	CK725F1A-105Z1	1	332181050R1

PCB-U007	C3523	C-CERA C	CK725F1A-105Z1	1	332181050R1
PCB-U007	C3524	C-CERA C	CK725F1A-105Z1	1	332181050R1
PCB-U007	C3525	C-CERA C	CK725F1A-105Z1	1	332181050R1
PCB-U007	C3526	C-CERA C	CK725F1A-105Z1	1	332181050R1
PCB-U007	C3527	C-CERA C	CK725F1A-105Z1	1	332181050R1
PCB-U007	C3528	C-CERA C	CK725F1A-105Z1	1	332181050R1
PCB-U007	C3529	C-CERA C	CK725F1A-105Z1	1	332181050R1
PCB-U007	C3530	C-CERA C	CK725F1A-105Z1	1	332181050R1
PCB-U007	C3531	C-CERA C	CK725F1A-105Z1	1	332181050R1
PCB-U007	C3532	C-CERA C	CK725F1A-105Z1	1	332181050R1
PCB-U007	C3533	C-CERA C	CK725F1A-105Z1	1	332181050R1
PCB-U007	C3534	C-CERA C	CK725F1A-105Z1	1	332181050R1
PCB-U007	C3535	C-CERA C	CK725F1A-105Z1	1	332181050R1
PCB-U007	C3536	C-CERA C	CK725F1A-105Z1	1	332181050R1
PCB-U007	C3537	C-CERA C	CK725F1A-105Z1	1	332181050R1
PCB-U007	C3538	C-CERA C	CK725F1A-105Z1	1	332181050R1
PCB-U007	C3539	C-CERA C	CK725F1A-105Z1	1	332181050R1
PCB-U007	C3540	C-CERA C	CK725F1A-105Z1	1	332181050R1
PCB-U007	C3541	C-CERA C	CK725F1A-105Z1	1	332181050R1
PCB-U007	C3542	C-CERA C	CK725B0J-106K	1	332091065R2
PCB-U007	C3543	C-CERA C	CK725F1A-105Z1	1	332181050R1
PCB-U007	C3544	C-CERA C	CC725CH1H-102J1	1	342101024R1
PCB-U007	C3545	C-CERA C	CK725F1A-105Z1	1	332181050R1
PCB-U007	C3546	C-CERA C	CK725B0J-106K	1	332091065R2
PCB-U007	C3547	C-CERA C	CK725B0J-106K	1	332091065R2
PCB-U007	C3548	C-CERA C	CK725B0J-106K	1	332091065R2
PCB-U007	C3549	C-CERA C	CK725F1A-105Z1	1	332181050R1
PCB-U007	C3550	C-CERA C	CK725F1A-105Z1	1	332181050R1
PCB-U007	C3551	C-CERA C	CK725F1A-105Z1	1	332181050R1
PCB-U007	C3552	CHIP ELECT C	CEWX4V-22M	1	3981G2207R2
PCB-U007	C3553	C-CERA C	CK725B1H-103K1	1	332101035R1
PCB-U007	C3554	C-CERA C	CK725F1A-105Z1	1	332181050R1
PCB-U007	C3555	C-CERA C	CK725B0J-106K	1	332091065R2

PCB-U007	C3556	C-CERA C	CK725F1A-105Z1	1	332181050R1
PCB-U007	C8001	C-CERA C	CK725B1H-102K1	1	332101025R1
PCB-U007	C8002	C-CERA C	CK725B1H-102K1	1	332101025R1
PCB-U007	C8003	C-CERA C	CK725B1C-104K1	1	332121045R1
PCB-U007	C8004	C-CERA C	CK725B1C-104K1	1	332121045R1
PCB-U007	C8005	C-CERA C	CK725B1C-104K1	1	332121045R1
PCB-U007	C8006	C-CERA C	CK725B1C-104K1	1	332121045R1
PCB-U007	C8007	C-CERA C	CK725B1C-104K1	1	332121045R1
PCB-U007	C8008	C-CERA C	CK725B1C-104K1	1	332121045R1
PCB-U007	C8009	C-CERA C	CK725B1C-104K1	1	332121045R1
PCB-U007	C8010	C-CERA C	CK725B1C-104K1	1	332121045R1
PCB-U007	C8011	C-CERA C	CK725B1C-104K1	1	332121045R1
PCB-U007	C8012	C-CERA C	CK725B1C-104K1	1	332121045R1
PCB-U007	C8013	C-CERA C	CK725B1C-104K1	1	332121045R1
PCB-U007	C8014	C-CERA C	CK725B1C-104K1	1	332121045R1
PCB-U007	C8015	CHIP ELECT C	CEWX16V-10M	1	398141007R2
PCB-U007	C8016	C-CERA C	CK725F1E-104Z1	1	332161040R1
PCB-U007	C8017	CHIP ELECT C	CEWX16V-10M	1	398141007R2
PCB-U007	C8018	C-CERA C	CK725F1E-104Z1	1	332161040R1
PCB-U007	C8019	C-CERA C	CK725B1H-103K1	1	332101035R1
PCB-U007	C8020	C-CERA C	CK725B1H-103K1	1	332101035R1
PCB-U007	C8021	C-CERA C	CK725F1E-104Z1	1	332161040R1
PCB-U007	C8022	C-CERA C	CK725F1E-104Z1	1	332161040R1
PCB-U007	C8023	CHIP ELECT C	CEWX16V-10M	1	398141007R2
PCB-U007	C8024	CHIP ELECT C	CEWX16V-10M	1	398141007R2
PCB-U007	C8025	C-CERA C	CK725F1E-104Z1	1	332161040R1
PCB-U007	C8026	C-CERA C	CK725F1E-104Z1	1	332161040R1
PCB-U007	C8027	C-CERA C	CK725F1E-104Z1	1	332161040R1
PCB-U007	C8028	C-CERA C	CK725F1E-104Z1	1	332161040R1
PCB-U007	C8029	C-CERA C	CK725B1H-103K1	1	332101035R1
PCB-U007	C8030	C-CERA C	CK725F1E-104Z1	1	332161040R1
PCB-U007	C8031	C-CERA C	CK725B1H-103K1	1	332101035R1
PCB-U007	C8032	CHIP ELECT C	CEWX4V-100M	1	3981G1017R2

PCB-U007	C8033	C-CERA C	CK725F1E-104Z1	1	332161040R1
PCB-U007	C8034	C-CERA C	CK725B1H-103K1	1	332101035R1
PCB-U007	C8035	C-CERA C	CK725F1E-104Z1	1	332161040R1
PCB-U007	C8036	C-CERA C	CK725B1H-103K1	1	332101035R1
PCB-U007	C8037	C-CERA C	CK725F1E-104Z1	1	332161040R1
PCB-U007	C8038	C-CERA C	CK725B1H-103K1	1	332101035R1
PCB-U007	C8039	C-CERA C	CK725F1E-104Z1	1	332161040R1
PCB-U007	C8040	C-CERA C	CK725B1H-103K1	1	332101035R1
PCB-U007	C8041	C-CERA C	CK725F1E-104Z1	1	332161040R1
PCB-U007	C8042	C-CERA C	CK725B1H-103K1	1	332101035R1
PCB-U007	C8043	C-CERA C	CK725F1E-104Z1	1	332161040R1
PCB-U007	C8044	C-CERA C	CK725B1H-103K1	1	332101035R1
PCB-U007	C8045	C-CERA C	CK725F1E-104Z1	1	332161040R1
PCB-U007	C8046	C-CERA C	CK725B1H-103K1	1	332101035R1
PCB-U007	C8047	C-CERA C	CK725F1E-104Z1	1	332161040R1
PCB-U007	C8048	C-CERA C	CK725B1H-103K1	1	332101035R1
PCB-U007	C8049	C-CERA C	CK725F1E-104Z1	1	332161040R1
PCB-U007	C8050	C-CERA C	CK725B1H-103K1	1	332101035R1
PCB-U007	C8051	C-CERA C	CK725F1E-104Z1	1	332161040R1
PCB-U007	C8052	C-CERA C	CK725F1E-104Z1	1	332161040R1
PCB-U007	C8053	C-CERA C	CK725B1H-103K1	1	332101035R1
PCB-U007	C8054	C-CERA C	CK725B1H-103K1	1	332101035R1
PCB-U007	C8055	C-CERA C	CK725F1E-104Z1	1	332161040R1
PCB-U007	C8056	C-CERA C	CK725B1H-103K1	1	332101035R1
PCB-U007	C8057	C-CERA C	CK725F1E-104Z1	1	332161040R1
PCB-U007	C8058	C-CERA C	CK725B1H-103K1	1	332101035R1
PCB-U007	C8060	C-CERA C	CK725F1A-105Z1	1	332181050R1
PCB-U007	C8061	C-CERA C	CK725F1E-104Z1	1	332161040R1
PCB-U007	C8062	C-CERA C	CK725F1E-104Z1	1	332161040R1
PCB-U007	C8063	CHIP TANTAL	F93-6.3V-100M	1	395521017R2
PCB-U007	C8063 or	CHIP TANTAL	TCSCS0J107MBAR	( 1)	396521017R2
PCB-U007	C8064	C-CERA C	CK725F1E-104Z1	1	332161040R1
PCB-U007	C8065	CHIP TANTAL	F93-6.3V-100M	1	395521017R2

PCB-U007	C8065 or	CHIP TANTAL	TCSCS0J107MBAR	( 1)	396521017R2
PCB-U007	C8066	C-CERA C	CK725F1E-104Z1	1	332161040R1
PCB-U007	C8069	CHIP TANTAL	F93-6.3V-100M	1	395521017R2
PCB-U007	C8069 or	CHIP TANTAL	TCSCS0J107MBAR	( 1)	396521017R2
PCB-U007	C8070	C-CERA C	CK725F1E-104Z1	1	332161040R1
PCB-U007	C8071	CHIP TANTAL	F93-6.3V-100M	1	395521017R2
PCB-U007	C8071 or	CHIP TANTAL	TCSCS0J107MBAR	( 1)	396521017R2
PCB-U007	C8072	C-CERA C	CK725F1E-104Z1	1	332161040R1
PCB-U007	C8075	C-CERA C	CK725F1E-104Z1	1	332161040R1
PCB-U007	C8076	C-CERA C	CK725F1E-104Z1	1	332161040R1
PCB-U007	C8077	C-CERA C	CK725F1E-104Z1	1	332161040R1
PCB-U007	C8078	C-CERA C	CK725F1E-104Z1	1	332161040R1
PCB-U007	C8079	C-CERA C	CK725F1E-104Z1	1	332161040R1
PCB-U007	C8080	C-CERA C	CK725F1E-104Z1	1	332161040R1
PCB-U007	C8081	C-CERA C	CK725F1E-104Z1	1	332161040R1
PCB-U007	C8082	C-CERA C	CK725F1E-104Z1	1	332161040R1
PCB-U007	C8083	C-CERA C	CK725F1E-104Z1	1	332161040R1
PCB-U007	C8084	C-CERA C	CK725F1E-104Z1	1	332161040R1
PCB-U007	C8085	C-CERA C	CK725F1E-104Z1	1	332161040R1
PCB-U007	C8086	C-CERA C	CK725F1E-104Z1	1	332161040R1
PCB-U007	C8087	C-CERA C	CK725F1A-105Z1	1	332181050R1
PCB-U007	C8088	C-CERA C	CK725F1A-105Z1	1	332181050R1
PCB-U007	C8089	C-CERA C	CK725F1A-105Z1	1	332181050R1
PCB-U007	C8090	C-CERA C	CK725F1A-105Z1	1	332181050R1
PCB-U007	C8091	C-CERA C	CK725F1A-105Z1	1	332181050R1
PCB-U007	C8092	C-CERA C	CK725F1A-105Z1	1	332181050R1
PCB-U007	C8093	C-CERA C	CK725F1A-105Z1	1	332181050R1
PCB-U007	C8094	C-CERA C	CK725F1A-105Z1	1	332181050R1
PCB-U007	C8095	C-CERA C	CK725F1E-104Z1	1	332161040R1
PCB-U007	C8096	C-CERA C	CK725F1E-104Z1	1	332161040R1
PCB-U007	C8097	C-CERA C	CK725F1E-104Z1	1	332161040R1
PCB-U007	C8098	C-CERA C	CK725F1E-104Z1	1	332161040R1
PCB-U007	C8099	C-CERA C	CK725F1E-104Z1	1	332161040R1

PCB-U007	C8100	C-CERA C	CC725CH1H-080D1	1	342100802R1
PCB-U007	C8101	C-CERA C	CC725CH1H-080D1	1	342100802R1
PCB-U007	C8102	C-CERA C	CK725B1C-823K1	1	332128235R1
PCB-U007	C8103	C-CERA C	CK725B1H-103K1	1	332101035R1
PCB-U007	C8104	C-CERA C	CK725B1A-105K1	1	332131055R1
PCB-U007	C8105	C-CERA C	CK725B1H-393K1	1	332103935R1
PCB-U007	C8106	C-CERA C	CK725F1E-104Z1	1	332161040R1
PCB-U007	C8107	C-CERA C	CK725B1H-103K1	1	332101035R1
PCB-U007	C8108	C-CERA C	CK725F1E-104Z1	1	332161040R1
PCB-U007	C8109	C-CERA C	CK725B1H-103K1	1	332101035R1
PCB-U007	C8110	C-CERA C	CK725F1E-104Z1	1	332161040R1
PCB-U007	C8111	C-CERA C	CK725B1H-103K1	1	332101035R1
PCB-U007	C8121	C-CERA C	CK725F1E-104Z1	1	332161040R1
PCB-U007	C8122	C-CERA C	CK725F1E-104Z1	1	332161040R1
PCB-U007	C8123	C-CERA C	CK725F1E-104Z1	1	332161040R1
PCB-U007	C8124	C-CERA C	CK725F1E-104Z1	1	332161040R1
PCB-U007	C8125	C-CERA C	CK725F1E-104Z1	1	332161040R1
PCB-U007	C8126	C-CERA C	CK725F1E-104Z1	1	332161040R1
PCB-U007	C8127	C-CERA C	CK725F1E-104Z1	1	332161040R1
PCB-U007	C8142	C-CARBON R	RN72K1J-000JE	1	435030004R1
PCB-U007	C8143	C-CERA C	CK725F1A-105Z1	1	332181050R1
PCB-U007	C8144	CHIP ELECT C	CEWX4V-100M	1	3981G1017R2
PCB-U007	C8145	C-CERA C	CK725F1E-104Z1	1	332161040R1
PCB-U007	C8146	C-CERA C	CK725F1E-104Z1	1	332161040R1
PCB-U007	C8147	CHIP TANTAL	F93-16V-10M	1	395541007R2
PCB-U007	C8147 or	CHIP TANTAL	TCSCS1C106MAAR	( 1)	396541007R2
PCB-U007	C8148	CHIP ELECT C	CEWX4V-100M	1	3981G1017R2
PCB-U007	C8161	C-CERA C	CK725F1A-105Z1	1	332181050R1
PCB-U007	C8162	CHIP ELECT C	CEWX4V-100M	1	3981G1017R2
PCB-U007	C8163	C-CERA C	CK725B1H-102K1	1	332101025R1
PCB-U007	C8164	C-CERA C	CK725B0J-106K	1	332091065R2
PCB-U007	C8165	C-CERA C	CK725F1E-104Z1	1	332161040R1
PCB-U007	C8166	C-CERA C	CK725B0J-106K	1	332091065R2

PCB-U007	C8167	C-CERA C	CK725F1E-104Z1	1	332161040R1
PCB-U007	C8168	C-CERA C	CK725B0J-106K	1	332091065R2
PCB-U007	C8169	C-CERA C	CK725F1E-104Z1	1	332161040R1
PCB-U007	C8170	C-CERA C	CK725F1E-104Z1	1	332161040R1
PCB-U007	C8171	C-CERA C	CK725F1E-104Z1	1	332161040R1
PCB-U007	C8172	C-CERA C	CK725F1E-104Z1	1	332161040R1
PCB-U007	C8173	C-CERA C	CK725F1E-104Z1	1	332161040R1
PCB-U007	C8174	C-CERA C	CK725F1E-104Z1	1	332161040R1
PCB-U007	C8175	C-CERA C	CK725F1E-104Z1	1	332161040R1
PCB-U007	C8176	C-CERA C	CK725F1E-104Z1	1	332161040R1
PCB-U007	C8177	C-CERA C	CK725F1E-104Z1	1	332161040R1
PCB-U007	C8178	C-CERA C	CK725F1E-104Z1	1	332161040R1
PCB-U007	C8179	C-CERA C	CK725F1E-104Z1	1	332161040R1
PCB-U007	C8180	C-CERA C	CK725F1E-104Z1	1	332161040R1
PCB-U007	C8181	C-CERA C	CK725F1E-104Z1	1	332161040R1
PCB-U007	C8200	C-CERA C	CK725F1E-104Z1	1	332161040R1
PCB-U007	C8201	C-CERA C	CK725F1E-104Z1	1	332161040R1
PCB-U007	C8202	C-CERA C	CK725F1E-104Z1	1	332161040R1
PCB-U007	C8203	CHIP TANTAL	F93-16V-10M	1	395541007R2
PCB-U007	C8203 or	CHIP TANTAL	TCSCS1C106MAAR	( 1 )	396541007R2
PCB-U007	C8204	C-CERA C	CK725F1E-104Z1	1	332161040R1
PCB-U007	C8205	C-CERA C	CK725F1E-104Z1	1	332161040R1
PCB-U007	C8206	C-CERA C	CK725F1E-104Z1	1	332161040R1
PCB-U007	C8207	C-CERA C	CK725F1E-104Z1	1	332161040R1
PCB-U007	C8208	C-CERA C	CK725F1E-104Z1	1	332161040R1
PCB-U007	C8209	C-CERA C	CK725F1E-104Z1	1	332161040R1
PCB-U007	C8210	C-CERA C	CK725F1E-104Z1	1	332161040R1
PCB-U007	C8211	C-CERA C	CK725F1E-104Z1	1	332161040R1
PCB-U007	C8212	C-CERA C	CK725F1E-104Z1	1	332161040R1
PCB-U007	C8213	C-CERA C	CK725F1E-104Z1	1	332161040R1
PCB-U007	C8214	C-CERA C	CK725F1E-104Z1	1	332161040R1
PCB-U007	C8215	CHIP TANTAL	F93-16V-10M	1	395541007R2
PCB-U007	C8215 or	CHIP TANTAL	TCSCS1C106MAAR	( 1 )	396541007R2

PCB-U007	C8216	C-CERA C	CK725F1A-105Z1	1	332181050R1
PCB-U007	C8217	C-CERA C	CK725F1A-105Z1	1	332181050R1
PCB-U007	C8218	C-CERA C	CK725F1A-105Z1	1	332181050R1
PCB-U007	C8219	C-CERA C	CK725F1A-105Z1	1	332181050R1
PCB-U007	C8220	C-CERA C	CK725F1A-105Z1	1	332181050R1
PCB-U007	C8221	C-CERA C	CK725F1A-105Z1	1	332181050R1
PCB-U007	C8222	C-CERA C	CK725F1E-104Z1	1	332161040R1
PCB-U007	C8223	CHIP TANTAL	F93-16V-10M	1	395541007R2
PCB-U007	C8223 or	CHIP TANTAL	TCSCS1C106MAAR	( 1)	396541007R2
PCB-U007	C8224	C-CERA C	CK725F1E-104Z1	1	332161040R1
PCB-U007	C8225	C-CERA C	CK725F1E-104Z1	1	332161040R1
PCB-U007	C8226	C-CERA C	CK725F1E-104Z1	1	332161040R1
PCB-U007	C8227	C-CERA C	CK725F1E-104Z1	1	332161040R1
PCB-U007	C8228	C-CERA C	CK725F1E-104Z1	1	332161040R1
PCB-U007	C8229	C-CERA C	CK725F1E-104Z1	1	332161040R1
PCB-U007	C8230	C-CERA C	CK725F1E-104Z1	1	332161040R1
PCB-U007	C8231	C-CERA C	CK725F1E-104Z1	1	332161040R1
PCB-U007	C8232	C-CERA C	CK725F1E-104Z1	1	332161040R1
PCB-U007	C8233	C-CERA C	CK725F1E-104Z1	1	332161040R1
PCB-U007	C8234	CHIP TANTAL	F93-16V-10M	1	395541007R2
PCB-U007	C8234 or	CHIP TANTAL	TCSCS1C106MAAR	( 1)	396541007R2
PCB-U007	C8235	C-CERA C	CK725F1E-104Z1	1	332161040R1
PCB-U007	C8236	C-CERA C	CK725F1E-104Z1	1	332161040R1
PCB-U007	C8237	C-CERA C	CK725F1E-104Z1	1	332161040R1
PCB-U007	C8238	C-CERA C	CK725F1E-104Z1	1	332161040R1
PCB-U007	C8239	C-CERA C	CK725F1E-104Z1	1	332161040R1
PCB-U007	C8240	C-CERA C	CK725F1E-104Z1	1	332161040R1
PCB-U007	C8241	C-CERA C	CK725F1E-104Z1	1	332161040R1
PCB-U007	C8242	CHIP TANTAL	F93-16V-10M	1	395541007R2
PCB-U007	C8242 or	CHIP TANTAL	TCSCS1C106MAAR	( 1)	396541007R2
PCB-U007	C8243	C-CERA C	CK725F1E-104Z1	1	332161040R1
PCB-U007	C8244	C-CERA C	CK725F1E-104Z1	1	332161040R1
PCB-U007	C8245	C-CERA C	CK725F1E-104Z1	1	332161040R1



PCB-U007	C8246	C-CERA C	CK725F1E-104Z1	1	332161040R1
PCB-U007	C8247	C-CERA C	CK725F1E-104Z1	1	332161040R1
PCB-U007	C8248	C-CERA C	CK725F1E-104Z1	1	332161040R1
PCB-U007	C8249	C-CERA C	CK725F1E-104Z1	1	332161040R1
PCB-U007	C8250	C-CERA C	CK725F1E-104Z1	1	332161040R1
PCB-U007	C8251	C-CERA C	CK725F1E-104Z1	1	332161040R1
PCB-U007	C8252	C-CERA C	CK725F1E-104Z1	1	332161040R1
PCB-U007	C8253	CHIP TANTAL	F93-16V-10M	1	395541007R2
PCB-U007	C8253 or	CHIP TANTAL	TCSCS1C106MAAR	( 1)	396541007R2
PCB-U007	C8254	C-CERA C	CK725F1E-104Z1	1	332161040R1
PCB-U007	C8255	C-CERA C	CK725F1E-104Z1	1	332161040R1
PCB-U007	C8256	C-CERA C	CK725F1E-104Z1	1	332161040R1
PCB-U007	C8257	C-CERA C	CK725F1E-104Z1	1	332161040R1
PCB-U007	C8258	C-CERA C	CK725F1E-104Z1	1	332161040R1
PCB-U007	C8259	C-CERA C	CK725F1E-104Z1	1	332161040R1
PCB-U007	C8260	C-CERA C	CK725F1A-105Z1	1	332181050R1
PCB-U007	C8261	CHIP TANTAL	F93-10V-220M	1	395532217R2
PCB-U007	C8261 or	CHIP TANTAL	TCSCS1A227MDAR	( 1)	396532217R2
PCB-U007	C8262	C-CERA C	CK725F1E-104Z1	1	332161040R1
PCB-U007	C8263	C-CERA C	CK725F1E-104Z1	1	332161040R1
PCB-U007	C8264	C-CERA C	CK725F1E-104Z1	1	332161040R1
PCB-U007	C8265	C-CERA C	CK725F1E-104Z1	1	332161040R1
PCB-U007	C8266	C-CERA C	CK725F1E-104Z1	1	332161040R1
PCB-U007	C8267	C-CERA C	CK725F1E-104Z1	1	332161040R1
PCB-U007	C8268	C-CERA C	CK725F1E-104Z1	1	332161040R1
PCB-U007	C8269	C-CERA C	CK725F1E-104Z1	1	332161040R1
PCB-U007	C8270	C-CERA C	CK725F1E-104Z1	1	332161040R1
PCB-U007	C8271	C-CERA C	CK725F1E-104Z1	1	332161040R1
PCB-U007	C8272	C-CERA C	CK725F1E-104Z1	1	332161040R1
PCB-U007	C8273	C-CERA C	CK725F1E-104Z1	1	332161040R1
PCB-U007	C8274	CHIP TANTAL	F93-16V-10M	1	395541007R2
PCB-U007	C8274 or	CHIP TANTAL	TCSCS1C106MAAR	( 1)	396541007R2
PCB-U007	C8275	C-CERA C	CK725F1A-105Z1	1	332181050R1

PCB-U007	C8276	C-CERA C	CK725F1A-105Z1	1	332181050R1
PCB-U007	C8277	C-CERA C	CK725F1A-105Z1	1	332181050R1
PCB-U007	C8278	C-CERA C	CK725F1A-105Z1	1	332181050R1
PCB-U007	C8279	C-CERA C	CK725F1A-105Z1	1	332181050R1
PCB-U007	C8280	C-CERA C	CK725F1A-105Z1	1	332181050R1
PCB-U007	C8281	C-CERA C	CK725F1A-105Z1	1	332181050R1
PCB-U007	C8282	C-CERA C	CK725F1E-104Z1	1	332161040R1
PCB-U007	C8283	C-CERA C	CK725F1E-104Z1	1	332161040R1
PCB-U007	C8284	C-CERA C	CK725F1E-104Z1	1	332161040R1
PCB-U007	C8285	C-CERA C	CK725F1E-104Z1	1	332161040R1
PCB-U007	C8286	C-CERA C	CK725F1E-104Z1	1	332161040R1
PCB-U007	C8287	C-CERA C	CK725F1E-104Z1	1	332161040R1
PCB-U007	C8288	C-CERA C	CK725F1E-104Z1	1	332161040R1
PCB-U007	C8289	C-CERA C	CK725F1E-104Z1	1	332161040R1
PCB-U007	C8290	C-CERA C	CK725F1E-104Z1	1	332161040R1
PCB-U007	C8291	C-CERA C	CK725F1E-104Z1	1	332161040R1
PCB-U007	C8292	C-CERA C	CK725F1E-104Z1	1	332161040R1
PCB-U007	C8293	C-CERA C	CK725F1E-104Z1	1	332161040R1
PCB-U007	C8294	C-CERA C	CK725F1E-104Z1	1	332161040R1
PCB-U007	C8295	C-CERA C	CK725F1E-104Z1	1	332161040R1
PCB-U007	C8303	C-CERA C	CK725B1H-223K1	1	332102235R1
PCB-U007	C8321	C-CARBON R	RN72K1J-000JE	1	435030004R1
PCB-U007	C8322	C-CARBON R	RN72K1J-000JE	1	435030004R1
PCB-U007	C8326	C-CERA C	CK725F1E-104Z1	1	332161040R1
PCB-U007	C8327	C-CERA C	CK725F1A-105Z1	1	332181050R1
PCB-U007	C8328	CHIP ELECT C	CEWX16V-22M	1	398142207R2
PCB-U007	C8329	C-CERA C	CK725F1A-105Z1	1	332181050R1
PCB-U007	C8330	C-CERA C	CK725F1A-105Z1	1	332181050R1
PCB-U007	C8332	C-CERA C	CK725F1E-104Z1	1	332161040R1
PCB-U007	C8341	C-CARBON R	RN72K1J-000JE	1	435030004R1
PCB-U007	C8342	C-CARBON R	RN72K1J-000JE	1	435030004R1
PCB-U007	C8348	C-CARBON R	RN72K1J-000JE	1	435030004R1
PCB-U007	C8349	C-CARBON R	RN72K1J-000JE	1	435030004R1

PCB-U007	C8356	C-CERA C	CK725F1E-104Z1	1	332161040R1
PCB-U007	C8357	C-CERA C	CK725F1A-105Z1	1	332181050R1
PCB-U007	C8358	CHIP ELECT C	CEWX16V-22M	1	398142207R2
PCB-U007	C8359	C-CERA C	CK725F1A-105Z1	1	332181050R1
PCB-U007	C8362	C-CERA C	CK725F1E-104Z1	1	332161040R1
PCB-U007	C8363	C-CERA C	CK725B1H-102K1	1	332101025R1
PCB-U007	C8364	C-CERA C	CK725B0J-106K	1	332091065R2
PCB-U007	C8365	C-CERA C	CK725F1E-104Z1	1	332161040R1
PCB-U007	C8366	C-CERA C	CK725B0J-106K	1	332091065R2
PCB-U007	C8367	C-CERA C	CK725F1E-104Z1	1	332161040R1
PCB-U007	C8368	C-CERA C	CK725B0J-106K	1	332091065R2
PCB-U007	C8369	C-CERA C	CK725F1E-104Z1	1	332161040R1
PCB-U007	C8370	C-CERA C	CK725F1E-104Z1	1	332161040R1
PCB-U007	C8371	C-CERA C	CK725F1E-104Z1	1	332161040R1
PCB-U007	C8372	C-CERA C	CK725F1E-104Z1	1	332161040R1
PCB-U007	C8373	C-CERA C	CK725F1E-104Z1	1	332161040R1
PCB-U007	C8374	C-CERA C	CK725F1E-104Z1	1	332161040R1
PCB-U007	C8375	C-CERA C	CK725F1E-104Z1	1	332161040R1
PCB-U007	C8376	C-CERA C	CK725F1E-104Z1	1	332161040R1
PCB-U007	C8377	C-CERA C	CK725F1E-104Z1	1	332161040R1
PCB-U007	C8378	C-CERA C	CK725F1E-104Z1	1	332161040R1
PCB-U007	C8379	C-CERA C	CK725F1E-104Z1	1	332161040R1
PCB-U007	C8380	C-CERA C	CK725F1E-104Z1	1	332161040R1
PCB-U007	C8381	C-CERA C	CK725F1E-104Z1	1	332161040R1
PCB-U007	C8390	C-CERA C	CK725F1A-105Z1	1	332181050R1
PCB-U007	C8398	C-CARBON R	RN72K1J-000JE	1	435030004R1
PCB-U007	C8399	C-CARBON R	RN72K1J-000JE	1	435030004R1
PCB-U007	C8401	CHIP ELECT C	CEWX4V-22M	1	3981G2207R2
PCB-U007	C8402	CHIP ELECT C	CEWX4V-22M	1	3981G2207R2
PCB-U007	C8403	C-CERA C	CK725F1A-105Z1	1	332181050R1
PCB-U007	C8404	C-CERA C	CK725B1H-102K1	1	332101025R1
PCB-U007	C8405	C-CERA C	CK725F1A-105Z1	1	332181050R1
PCB-U007	C8406	C-CERA C	CK725B1H-102K1	1	332101025R1

PCB-U007	C8408	CHIP ELECT C	CEWX4V-22M	1	3981G2207R2
PCB-U007	C8409	CHIP ELECT C	CEWX4V-22M	1	3981G2207R2
PCB-U007	C8410	C-CERA C	CK725F1A-105Z1	1	332181050R1
PCB-U007	C8411	C-CERA C	CK725B1H-102K1	1	332101025R1
PCB-U007	C8412	C-CERA C	CK725F1A-105Z1	1	332181050R1
PCB-U007	C8413	C-CERA C	CK725B1H-102K1	1	332101025R1
PCB-U007	C8414	C-CERA C	CK725F1A-105Z1	1	332181050R1
PCB-U007	C8415	C-CERA C	CK725B1H-102K1	1	332101025R1
PCB-U007	C8416	C-CERA C	CK725B1H-102K1	1	332101025R1
PCB-U007	C8417	C-CERA C	CK725F1A-105Z1	1	332181050R1
PCB-U007	C8418	CHIP ELECT C	CEWX4V-22M	1	3981G2207R2
PCB-U007	C8419	C-CERA C	CK725B1H-102K1	1	332101025R1
PCB-U007	C8420	C-CERA C	CK725F1A-105Z1	1	332181050R1
PCB-U007	C8421	C-CERA C	CK725B1H-102K1	1	332101025R1
PCB-U007	C8422	C-CERA C	CK725F1A-105Z1	1	332181050R1
PCB-U007	C8423	C-CERA C	CK725B1H-102K1	1	332101025R1
PCB-U007	C8424	C-CERA C	CK725F1A-105Z1	1	332181050R1
PCB-U007	C8425	C-CERA C	CK725B1H-102K1	1	332101025R1
PCB-U007	C8426	C-CERA C	CK725F1A-105Z1	1	332181050R1
PCB-U007	C8427	C-CERA C	CK725B1H-102K1	1	332101025R1
PCB-U007	C8428	C-CERA C	CK725F1A-105Z1	1	332181050R1
PCB-U007	C8429	C-CERA C	CK725B1H-102K1	1	332101025R1
PCB-U007	C8430	C-CERA C	CK725F1A-105Z1	1	332181050R1
PCB-U007	C8431	C-CERA C	CK725B1H-102K1	1	332101025R1
PCB-U007	C8432	C-CERA C	CK725F1A-105Z1	1	332181050R1
PCB-U007	C8433	C-CERA C	CK725B1H-102K1	1	332101025R1
PCB-U007	C8434	C-CERA C	CK725F1A-105Z1	1	332181050R1
PCB-U007	C8435	C-CERA C	CK725F1A-105Z1	1	332181050R1
PCB-U007	C8436	C-CERA C	CK725F1A-105Z1	1	332181050R1
PCB-U007	C8437	CHIP ELECT C	CEWX4V-22M	1	3981G2207R2
PCB-U007	C8438	C-CERA C	CK725B1H-102K1	1	332101025R1
PCB-U007	C8439	C-CERA C	CK725F1A-105Z1	1	332181050R1
PCB-U007	C8440	C-CERA C	CK725B0J-106K	1	332091065R2

PCB-U007	C8451	CHIP ELECT C	CEWX4V-22M	1	3981G2207R2
PCB-U007	C8452	CHIP ELECT C	CEWX4V-22M	1	3981G2207R2
PCB-U007	C8453	C-CERA C	CK725F1A-105Z1	1	332181050R1
PCB-U007	C8454	C-CERA C	CK725B1H-102K1	1	332101025R1
PCB-U007	C8455	C-CERA C	CK725F1A-105Z1	1	332181050R1
PCB-U007	C8456	C-CERA C	CK725B1H-102K1	1	332101025R1
PCB-U007	C8458	CHIP ELECT C	CEWX4V-22M	1	3981G2207R2
PCB-U007	C8459	CHIP ELECT C	CEWX4V-22M	1	3981G2207R2
PCB-U007	C8460	C-CERA C	CK725F1A-105Z1	1	332181050R1
PCB-U007	C8461	C-CERA C	CK725B1H-102K1	1	332101025R1
PCB-U007	C8462	C-CERA C	CK725F1A-105Z1	1	332181050R1
PCB-U007	C8463	C-CERA C	CK725B1H-102K1	1	332101025R1
PCB-U007	C8464	C-CERA C	CK725F1A-105Z1	1	332181050R1
PCB-U007	C8465	C-CERA C	CK725B1H-102K1	1	332101025R1
PCB-U007	C8466	C-CERA C	CK725B1H-102K1	1	332101025R1
PCB-U007	C8467	C-CERA C	CK725F1A-105Z1	1	332181050R1
PCB-U007	C8468	CHIP ELECT C	CEWX4V-22M	1	3981G2207R2
PCB-U007	C8469	C-CERA C	CK725B1H-102K1	1	332101025R1
PCB-U007	C8470	C-CERA C	CK725F1A-105Z1	1	332181050R1
PCB-U007	C8471	C-CERA C	CK725B1H-102K1	1	332101025R1
PCB-U007	C8472	C-CERA C	CK725F1A-105Z1	1	332181050R1
PCB-U007	C8473	C-CERA C	CK725B1H-102K1	1	332101025R1
PCB-U007	C8474	C-CERA C	CK725F1A-105Z1	1	332181050R1
PCB-U007	C8475	C-CERA C	CK725B1H-102K1	1	332101025R1
PCB-U007	C8476	C-CERA C	CK725F1A-105Z1	1	332181050R1
PCB-U007	C8477	C-CERA C	CK725B1H-102K1	1	332101025R1
PCB-U007	C8478	C-CERA C	CK725F1A-105Z1	1	332181050R1
PCB-U007	C8479	C-CERA C	CK725B1H-102K1	1	332101025R1
PCB-U007	C8480	C-CERA C	CK725F1A-105Z1	1	332181050R1
PCB-U007	C8481	C-CERA C	CK725B1H-102K1	1	332101025R1
PCB-U007	C8482	C-CERA C	CK725F1A-105Z1	1	332181050R1
PCB-U007	C8483	C-CERA C	CK725B1H-102K1	1	332101025R1
PCB-U007	C8484	C-CERA C	CK725F1A-105Z1	1	332181050R1

PCB-U007	C8485	C-CERA C	CK725F1A-105Z1	1	332181050R1
PCB-U007	C8486	C-CERA C	CK725F1A-105Z1	1	332181050R1
PCB-U007	C8487	CHIP ELECT C	CEWX4V-22M	1	3981G2207R2
PCB-U007	C8488	C-CERA C	CK725B1H-102K1	1	332101025R1
PCB-U007	C8489	C-CERA C	CK725F1A-105Z1	1	332181050R1
PCB-U007	C8490	C-CERA C	CK725B0J-106K	1	332091065R2
PCB-U007	C8501	C-CERA C	CK725B1H-102K1	1	332101025R1
PCB-U007	C8502	C-CERA C	CK725B0J-106K	1	332091065R2
PCB-U007	C8503	C-CERA C	CK725F1A-105Z1	1	332181050R1
PCB-U007	C8504	C-CERA C	CK725B1H-102K1	1	332101025R1
PCB-U007	C8505	C-CERA C	CK725F1A-105Z1	1	332181050R1
PCB-U007	C8506	C-CERA C	CK725B0J-106K	1	332091065R2
PCB-U007	C8507	C-CERA C	CK725B1H-102K1	1	332101025R1
PCB-U007	C8508	C-CERA C	CK725F1A-105Z1	1	332181050R1
PCB-U007	C8509	C-CERA C	CK725B1H-102K1	1	332101025R1
PCB-U007	C8510	C-CERA C	CK725F1A-105Z1	1	332181050R1
PCB-U007	C8511	C-CERA C	CK725B1H-102K1	1	332101025R1
PCB-U007	C8512	C-CERA C	CK725F1A-105Z1	1	332181050R1
PCB-U007	C8513	C-CERA C	CK725B1H-102K1	1	332101025R1
PCB-U007	C8514	C-CERA C	CK725F1A-105Z1	1	332181050R1
PCB-U007	C8515	C-CERA C	CK725B1H-102K1	1	332101025R1
PCB-U007	C8516	C-CERA C	CK725F1A-105Z1	1	332181050R1
PCB-U007	C8517	C-CERA C	CK725B1H-102K1	1	332101025R1
PCB-U007	C8518	C-CERA C	CK725F1A-105Z1	1	332181050R1
PCB-U007	C8519	C-CERA C	CK725F1A-105Z1	1	332181050R1
PCB-U007	C8521	C-CERA C	CK725F1E-104Z1	1	332161040R1
PCB-U007	C8522	C-CERA C	CK725B0J-106K	1	332091065R2
PCB-U007	C8525	C-CERA C	CK725B0J-106K	1	332091065R2
PCB-U007	C8527	C-CERA C	CK725B1H-102K1	1	332101025R1
PCB-U007	C8529	C-CERA C	CK725B0J-106K	1	332091065R2
PCB-U007	C8530	C-CERA C	CK725F1A-105Z1	1	332181050R1
PCB-U007	C8531	C-CERA C	CK725B1H-102K1	1	332101025R1
PCB-U007	C8532	C-CERA C	CK725F1A-105Z1	1	332181050R1

PCB-U007	C8533	C-CERA C	CK725B1H-102K1	1	332101025R1
PCB-U007	C8534	C-CERA C	CK725F1A-105Z1	1	332181050R1
PCB-U007	C8535	C-CERA C	CK725B1H-102K1	1	332101025R1
PCB-U007	C8536	C-CERA C	CK725F1A-105Z1	1	332181050R1
PCB-U007	C8537	C-CERA C	CK725B1H-102K1	1	332101025R1
PCB-U007	C8538	C-CERA C	CK725F1A-105Z1	1	332181050R1
PCB-U007	C8539	C-CERA C	CK725B1H-102K1	1	332101025R1
PCB-U007	C8540	C-CERA C	CK725F1A-105Z1	1	332181050R1
PCB-U007	C8548	C-CERA C	CK725F1A-105Z1	1	332181050R1
PCB-U007	C8549	C-CERA C	CK725B1H-102K1	1	332101025R1
PCB-U007	C8550	C-CERA C	CK725F1A-105Z1	1	332181050R1
PCB-U007	C8551	C-CERA C	CK725B1H-102K1	1	332101025R1
PCB-U007	C8552	C-CERA C	CK725F1A-105Z1	1	332181050R1
PCB-U007	C8553	C-CERA C	CK725B1H-102K1	1	332101025R1
PCB-U007	C8554	C-CERA C	CK725F1A-105Z1	1	332181050R1
PCB-U007	C8555	C-CERA C	CK725B1H-102K1	1	332101025R1
PCB-U007	C8556	C-CERA C	CK725F1A-105Z1	1	332181050R1
PCB-U007	C8557	C-CERA C	CK725B1H-102K1	1	332101025R1
PCB-U007	C8558	C-CERA C	CK725F1A-105Z1	1	332181050R1
PCB-U007	C8559	C-CERA C	CK725B1H-102K1	1	332101025R1
PCB-U007	C8560	C-CERA C	CK725B0J-106K	1	332091065R2
PCB-U007	C8563	C-CERA C	CK725F1A-105Z1	1	332181050R1
PCB-U007	C8564	C-CERA C	CK725B0J-106K	1	332091065R2
PCB-U007	C8565	C-CERA C	CK725B0J-106K	1	332091065R2
PCB-U007	C8566	C-CERA C	CK725B1H-102K1	1	332101025R1
PCB-U007	C8567	C-CERA C	CK725F1A-105Z1	1	332181050R1
PCB-U007	C8573	C-CERA C	CK725F1A-105Z1	1	332181050R1
PCB-U007	C8584	C-CERA C	CK725B0J-106K	1	332091065R2
PCB-U007	C8585	C-CERA C	CK725B0J-106K	1	332091065R2
PCB-U007	C8605	C-CARBON R	RN72K1J-000JE	1	435030004R1
PCB-U007	C8608	C-CERA C	CK725F1A-105Z1	1	332181050R1
PCB-U007	C8609	C-CERA C	CK725B0J-106K	1	332091065R2
PCB-U007	C8611	C-CARBON R	RN72K1J-000JE	1	435030004R1

PCB-U007	C8612	C-CARBON R	RN72K1J-000JE	1	435030004R1
PCB-U007	C8621	C-CARBON R	RN72K1J-000JE	1	435030004R1
PCB-U007	C8622	C-CARBON R	RN72K1J-000JE	1	435030004R1
PCB-U007	C8631	C-CARBON R	RN72K1J-000JE	1	435030004R1
PCB-U007	C8632	C-CARBON R	RN72K1J-000JE	1	435030004R1
PCB-U007	C8675	CHIP ELECT C	CEWX4V-100M	1	3981G1017R2
PCB-U007	C8676	C-CERA C	CK725F1A-105Z1	1	332181050R1
PCB-U007	C8685	C-CERA C	CK725F1E-104Z1	1	332161040R1
PCB-U007	C8701	C-CERA C	CK725F1A-105Z1	1	332181050R1
PCB-U007	C8702	C-CERA C	CK725F1A-105Z1	1	332181050R1
PCB-U007	C8703	C-CERA C	CK725F1A-105Z1	1	332181050R1
PCB-U007	C8704	CHIP ELECT C	CEWX50V-4.7M	1	398180477R2
PCB-U007	C8705	C-CERA C	CK725F1A-105Z1	1	332181050R1
PCB-U007	C8706	C-CERA C	CK725F1A-105Z1	1	332181050R1
PCB-U007	C8707	C-CERA C	CK725F1A-105Z1	1	332181050R1
PCB-U007	C8708	C-CERA C	CK725F1A-105Z1	1	332181050R1
PCB-U007	C8709	CHIP ELECT C	CEWX4V-220M	1	3981G2217R2
PCB-U007	C8710	C-CERA C	CK725F1A-105Z1	1	332181050R1
PCB-U007	C8801	C-CERA C	CK725F1A-105Z1	1	332181050R1
PCB-U007	C8802	CHIP ELECT C	CEWX4V-220M	1	3981G2217R2
PCB-U007	C8803	CHIP ELECT C	CEWX4V-220M	1	3981G2217R2
PCB-U007	C8804	CHIP ELECT C	CEWX4V-220M	1	3981G2217R2
PCB-U007	C8805	CHIP ELECT C	CEWX4V-220M	1	3981G2217R2
PCB-U007	C8810	C-CERA C	CK725F1A-105Z1	1	332181050R1
PCB-U007	C8811	C-CERA C	CK725F1A-105Z1	1	332181050R1
PCB-U007	C8812	C-CERA C	CK725B1A-154K1	1	332131545R1
PCB-U007	C8813	C-CERA C	CK725B1H-153K1	1	332101535R1
PCB-U007	C8814	C-CERA C	CK725F1A-105Z1	1	332181050R1
PCB-U007	C8815	C-CERA C	CK725B1A-154K1	1	332131545R1
PCB-U007	C8816	C-CERA C	CK725B1H-153K1	1	332101535R1
PCB-U007	C8817	C-CERA C	CK725B1H-222K1	1	332102225R1
PCB-U007	C8818	C-CERA C	CK725F1A-105Z1	1	332181050R1
PCB-U007	C8819	C-CERA C	CK725B1H-222K1	1	332102225R1



PCB-U007	C8820	C-CERA C	CK725F1A-105Z1	1	332181050R1
PCB-U007	C8821	C-CERA C	CK725F1A-105Z1	1	332181050R1
PCB-U007	C8822	C-CERA C	CK725F1A-105Z1	1	332181050R1
PCB-U007	C8823	C-CERA C	CK725F1A-105Z1	1	332181050R1
PCB-U007	C8825	C-CERA C	CK725B0J-225K	1	332092255R1
PCB-U007	C8826	CHIP ELECT C	CEWX4V-100M	1	3981G1017R2
PCB-U007	C8838	C-CERA C	CC725CH1H-470J1	1	342104704R1
PCB-U007	C8839	C-CERA C	CC725CH1H-470J1	1	342104704R1
PCB-U007	C8840	C-CERA C	CC725CH1H-470J1	1	342104704R1
PCB-U007	C8855	C-CERA C	CK725F1E-104Z1	1	332161040R1
PCB-U007	C8856	C-CERA C	CK725F1E-104Z1	1	332161040R1
PCB-U007	C8857	C-CERA C	CK725F1E-104Z1	1	332161040R1
PCB-U007	C8858	C-CERA C	CK725F1E-104Z1	1	332161040R1
PCB-U007	C8859	C-CERA C	CK725F1E-104Z1	1	332161040R1
PCB-U007	C8860	C-CERA C	CK725F1E-104Z1	1	332161040R1
PCB-U007	C8861	C-CERA C	CK725F1E-104Z1	1	332161040R1
PCB-U007	C8862	C-CERA C	CK725F1E-104Z1	1	332161040R1
PCB-U007	C8863	C-CERA C	CK725F1E-104Z1	1	332161040R1
PCB-U007	C8864	C-CERA C	CK725F1E-104Z1	1	332161040R1
PCB-U007	C8865	C-CERA C	CK725F1E-104Z1	1	332161040R1
PCB-U007	C8866	C-CERA C	CK725F1E-104Z1	1	332161040R1
PCB-U007	C8867	C-CERA C	CK725F1E-104Z1	1	332161040R1
PCB-U007	C8868	C-CERA C	CK725F1E-104Z1	1	332161040R1
PCB-U007	C8869	C-CERA C	CK725F1E-104Z1	1	332161040R1
PCB-U007	C8870	C-CERA C	CK725F1E-104Z1	1	332161040R1
PCB-U007	C8871	C-CERA C	CK725F1E-104Z1	1	332161040R1
PCB-U007	C8872	C-CERA C	CK725F1E-104Z1	1	332161040R1
PCB-U007	C8873	C-CERA C	CK725F1E-104Z1	1	332161040R1
PCB-U007	C8874	C-CERA C	CK725F1E-104Z1	1	332161040R1
PCB-U007	C8875	C-CERA C	CK725F1E-104Z1	1	332161040R1
PCB-U007	C8876	C-CERA C	CK725F1E-104Z1	1	332161040R1
PCB-U007	C8877	C-CERA C	CK725F1E-104Z1	1	332161040R1
PCB-U007	C8878	C-CERA C	CK725F1E-104Z1	1	332161040R1

PCB-U007	C8879	C-CERA C	CK725F1E-104Z1	1	332161040R1
PCB-U007	C8880	C-CERA C	CK725F1E-104Z1	1	332161040R1
PCB-U007	C8881	C-CERA C	CK725F1E-104Z1	1	332161040R1
PCB-U007	C8882	C-CERA C	CK725F1E-104Z1	1	332161040R1
PCB-U007	C8883	C-CERA C	CK725F1E-104Z1	1	332161040R1
PCB-U007	C8884	C-CERA C	CK725F1E-104Z1	1	332161040R1
PCB-U007	C8885	C-CERA C	CK725F1E-104Z1	1	332161040R1
PCB-U007	C8886	C-CERA C	CK725F1E-104Z1	1	332161040R1
PCB-U007	C8887	C-CERA C	CK725F1E-104Z1	1	332161040R1
PCB-U007	C8888	C-CERA C	CK725F1E-104Z1	1	332161040R1
PCB-U007	C8889	C-CERA C	CK725F1E-104Z1	1	332161040R1
PCB-U007	C8890	C-CERA C	CK725F1E-104Z1	1	332161040R1
PCB-U007	C8891	C-CERA C	CK725F1E-104Z1	1	332161040R1
PCB-U007	C8892	C-CERA C	CK725F1E-104Z1	1	332161040R1
PCB-U007	C8893	C-CERA C	CK725F1E-104Z1	1	332161040R1
PCB-U007	C8894	C-CERA C	CK725F1E-104Z1	1	332161040R1
PCB-U007	C8921	CHIP TANTAL	F93-10V-220M	1	395532217R2
PCB-U007	C8921 or	CHIP TANTAL	TCSCS1A227MDAR	( 1)	396532217R2
PCB-U007	C8922	C-CERA C	CK725F1E-104Z1	1	332161040R1
PCB-U007	C8923	C-CERA C	CK725F1E-104Z1	1	332161040R1
PCB-U007	C8924	C-CERA C	CC725CH1H-090D1	1	342100902R1
PCB-U007	C8925	C-CERA C	CC725CH1H-090D1	1	342100902R1
PCB-U007	C8926	CHIP TANTAL	F93-10V-47M	1	395534707R2
PCB-U007	C8926 or	CHIP TANTAL	TCSCS1A476MBAR	( 1)	396534707R2
PCB-U007	C8927	C-CERA C	CK725F1E-104Z1	1	332161040R1
PCB-U007	C8928	C-CERA C	CC725CH1H-101J1	1	342101014R1
PCB-U007	C8951	C-CERA C	CK725B1C-104K1	1	332121045R1
PCB-U007	C8952	C-CERA C	CK725F1A-105Z1	1	332181050R1
PCB-U007	C8953	CD C	UCD1E221MNL1GS	1	396652217R2
PCB-U007	C8954	C-CERA C	CK725B1H-103K1	1	332101035R1
PCB-U007	C8955	C-CERA C	CK725B1H-332K1	1	332103325R1
PCB-U007	C8956	C-CERA C	CK725F1A-105Z1	1	332181050R1
PCB-U007	C8957	CD C	UCD1A471MNL1GS	1	396634717R2

PCB-U007	C8958	C-CERA C	CK725F1A-105Z1	1	332181050R1
PCB-U007	C8961	C-CERA C	CK725B1A-224K1	1	332132245R1
PCB-U007	C8962	C-CERA C	CK725F1A-105Z1	1	332181050R1
PCB-U007	C8963	CD C	UCD1E221MNL1GS	1	396652217R2
PCB-U007	C8964	C-CERA C	CK725B1H-332K1	1	332103325R1
PCB-U007	C8965	C-CERA C	CK725B1H-332K1	1	332103325R1
PCB-U007	C8966	C-CERA C	CK725F1A-105Z1	1	332181050R1
PCB-U007	C8967	CD C	UCD1A471MNL1GS	1	396634717R2
PCB-U007	C8968	C-CERA C	CK725F1A-105Z1	1	332181050R1
PCB-U007	C8971	C-CERA C	CK725B1C-104K1	1	332121045R1
PCB-U007	C8972	C-CERA C	CK725F1A-105Z1	1	332181050R1
PCB-U007	C8973	CD C	UCD1E221MNL1GS	1	396652217R2
PCB-U007	C8974	C-CERA C	CK725B1H-332K1	1	332103325R1
PCB-U007	C8975	C-CERA C	CK725B1H-332K1	1	332103325R1
PCB-U007	C8976	C-CERA C	CK725F1A-105Z1	1	332181050R1
PCB-U007	C8977	CD C	UCD1A471MNL1GS	1	396634717R2
PCB-U007	C8978	C-CERA C	CK725F1A-105Z1	1	332181050R1
PCB-U007	C8979	C-CERA C	CK725F1A-105Z1	1	332181050R1
PCB-U007	C8981	C-CERA C	CK725B1H-223K1	1	332102235R1
PCB-U007	C8982	C-CERA C	CK725F1A-105Z1	1	332181050R1
PCB-U007	C8983	CD C	UCD1E221MNL1GS	1	396652217R2
PCB-U007	C8984	C-CERA C	CK725B1H-103K1	1	332101035R1
PCB-U007	C8985	C-CERA C	CK725B1H-222K1	1	332102225R1
PCB-U007	C8986	C-CERA C	CK725F1A-105Z1	1	332181050R1
PCB-U007	C8987	CD C	UCD1A471MNL1GS	1	396634717R2
PCB-U007	C8988	C-CERA C	CK725F1A-105Z1	1	332181050R1
PCB-U007	[RESISTOR]				
PCB-U007	R268	C-CARBON R	RN72K1J-331JE	1	435033314R1
PCB-U007	R269	C-CARBON R	RN72K1J-331JE	1	435033314R1
PCB-U007	R270	C-CARBON R	RN72K1J-331JE	1	435033314R1
PCB-U007	R271	C-CARBON R	RN72K1J-470JE	1	435034704R1
PCB-U007	R272	C-CARBON R	RN72K1J-331JE	1	435033314R1
PCB-U007	R273	C-CARBON R	RN72K1J-331JE	1	435033314R1

PCB-U007	R274	C-CARBON R	RN72K1J-470JE	1	435034704R1
PCB-U007	R275	C-CARBON R	RN72K1J-221JE	1	435032214R1
PCB-U007	R276	C-CARBON R	RN72K1J-221JE	1	435032214R1
PCB-U007	R277	C-CARBON R	RN72K1J-151JE	1	435031514R1
PCB-U007	R278	C-CARBON R	RN72K1J-331JE	1	435033314R1
PCB-U007	R279	C-CARBON R	RN72K1J-331JE	1	435033314R1
PCB-U007	R280	C-CARBON R	RN72K1J-470JE	1	435034704R1
PCB-U007	R3009	C-CARBON R	RN72K1J-330JE	1	435033304R1
PCB-U007	R3010	C-R NET	RM7LJ330X04	1	43484733004R2
PCB-U007	R3011	C-R NET	RM7LJ330X04	1	43484733004R2
PCB-U007	R3012	C-R NET	RM7LJ470X04	1	43484747004R2
PCB-U007	R3013	C-R NET	RM7LJ330X04	1	43484733004R2
PCB-U007	R3014	C-R NET	RM7LJ330X04	1	43484733004R2
PCB-U007	R3015	C-R NET	RM7LJ330X04	1	43484733004R2
PCB-U007	R3016	C-CARBON R	RN72K1J-470JE	1	435034704R1
PCB-U007	R3017	C-R NET	RM7LJ330X04	1	43484733004R2
PCB-U007	R3018	C-CARBON R	RN72K1J-470JE	1	435034704R1
PCB-U007	R3019	C-R NET	RM7LJ330X04	1	43484733004R2
PCB-U007	R3020	C-R NET	RM7LJ330X04	1	43484733004R2
PCB-U007	R3021	C-CARBON R	RN72K1J-470JE	1	435034704R1
PCB-U007	R3022	C-CARBON R	RN72K1J-470JE	1	435034704R1
PCB-U007	R3023	C-R NET	RM7LJ470X04	1	43484747004R2
PCB-U007	R3024	C-CARBON R	RN72K1J-470JE	1	435034704R1
PCB-U007	R3025	C-CARBON R	RN72K1J-102JE	1	435031024R1
PCB-U007	R3026	C-CARBON R	RN72K1J-470JE	1	435034704R1
PCB-U007	R3028	C-CARBON R	RN72K1J-470JE	1	435034704R1
PCB-U007	R3029	C-CARBON R	RN72K1J-102JE	1	435031024R1
PCB-U007	R3032	C-CARBON R	RN72K1J-103JE	1	435031034R1
PCB-U007	R3033	C-CARBON R	RN72K1J-470JE	1	435034704R1
PCB-U007	R3034	C-CARBON R	RN72K1J-470JE	1	435034704R1
PCB-U007	R3035	C-CARBON R	RN72K1J-470JE	1	435034704R1
PCB-U007	R3036	C-CARBON R	RN72K1J-470JE	1	435034704R1
PCB-U007	R3037	C-CARBON R	RN72K1J-470JE	1	435034704R1

PCB-U007	R3038	C-CARBON R	RN72K1J-470JE	1	435034704R1
PCB-U007	R3039	C-CARBON R	RN72K1J-470JE	1	435034704R1
PCB-U007	R3040	C-CARBON R	RN72K1J-103JE	1	435031034R1
PCB-U007	R3041	C-R NET	RM7LJ330X04	1	43484733004R2
PCB-U007	R3042	C-R NET	RM7LJ330X04	1	43484733004R2
PCB-U007	R3043	C-CARBON R	RN72K1J-000JE	1	435030004R1
PCB-U007	R3044	C-R NET	RM7LJ330X04	1	43484733004R2
PCB-U007	R3045	C-R NET	RM7LJ330X04	1	43484733004R2
PCB-U007	R3047	C-CARBON R	RN72K1J-560JE	1	435035604R1
PCB-U007	R3048	C-CARBON R	RN72K1J-000JE	1	435030004R1
PCB-U007	R3049	C-CARBON R	RN72K1J-560JE	1	435035604R1
PCB-U007	R3050	C-CARBON R	RN72K1J-560JE	1	435035604R1
PCB-U007	R3051	C-CARBON R	RN72K1J-560JE	1	435035604R1
PCB-U007	R3052	C-CARBON R	RN72K1J-103JE	1	435031034R1
PCB-U007	R3053	C-CARBON R	RN72K1J-103JE	1	435031034R1
PCB-U007	R3054	C-CARBON R	RN72K1J-103JE	1	435031034R1
PCB-U007	R3055	C-CARBON R	RN72K1J-472JE	1	435034724R1
PCB-U007	R3056	C-CARBON R	RN72K1J-472JE	1	435034724R1
PCB-U007	R3060	C-CARBON R	RN72K1J-680JE	1	435036804R1
PCB-U007	R3061	C-CARBON R	RN72K1J-470JE	1	435034704R1
PCB-U007	R3062	C-CARBON R	RN72K1J-680JE	1	435036804R1
PCB-U007	R3063	C-CARBON R	RN72K1J-680JE	1	435036804R1
PCB-U007	R3064	C-CARBON R	RN72K1J-680JE	1	435036804R1
PCB-U007	R3065	C-CARBON R	RN72K1J-680JE	1	435036804R1
PCB-U007	R3066	C-CARBON R	RN72K1J-102JE	1	435031024R1
PCB-U007	R3101	C-CARBON R	RN72K1J-103JE	1	435031034R1
PCB-U007	R3102	C-CARBON R	RN72K1J-153JE	1	435031534R1
PCB-U007	R3108	C-CARBON R	RN72K1J-103JE	1	435031034R1
PCB-U007	R3113	C-CARBON R	RN72K1J-103JE	1	435031034R1
PCB-U007	R3115	C-CARBON R	RN72K1J-103JE	1	435031034R1
PCB-U007	R3117	C-CARBON R	RN72K1J-103JE	1	435031034R1
PCB-U007	R3119	C-CARBON R	RN72K1J-472JE	1	435034724R1
PCB-U007	R3121	C-CARBON R	RN72K1J-153JE	1	435031534R1

PCB-U007	R3122	C-CARBON R	RN72K1J-102JE	1	435031024R1
PCB-U007	R3123	C-CARBON R	RN72K1J-000JE	1	435030004R1
PCB-U007	R3124	C-CARBON R	RN72K1J-331JE	1	435033314R1
PCB-U007	R3125	C-CARBON R	RN72K1J-470JE	1	435034704R1
PCB-U007	R3126	C-CARBON R	RN72K1J-470JE	1	435034704R1
PCB-U007	R3127	C-CARBON R	RN72K1J-470JE	1	435034704R1
PCB-U007	R3128	C-CARBON R	RN72K1J-472JE	1	435034724R1
PCB-U007	R3129	C-CARBON R	RN72K1J-470JE	1	435034704R1
PCB-U007	R3130	C-CARBON R	RN72K1J-470JE	1	435034704R1
PCB-U007	R3131	C-CARBON R	RN72K1J-470JE	1	435034704R1
PCB-U007	R3132	C-CARBON R	RN72K1J-103JE	1	435031034R1
PCB-U007	R3133	C-CARBON R	RN72K1J-680JE	1	435036804R1
PCB-U007	R3134	C-CARBON R	RN72K1J-103JE	1	435031034R1
PCB-U007	R3135	C-CARBON R	RN72K1J-103JE	1	435031034R1
PCB-U007	R3136	C-CARBON R	RN72K1J-000JE	1	435030004R1
PCB-U007	R3137	C-CARBON R	RN72K1J-000JE	1	435030004R1
PCB-U007	R3139	C-CARBON R	RN72K1J-101JE	1	435031014R1
PCB-U007	R3143	C-CARBON R	RN72K1J-103JE	1	435031034R1
PCB-U007	R3144	C-CARBON R	RN72K1J-101JE	1	435031014R1
PCB-U007	R3145	C-CARBON R	RN72K1J-103JE	1	435031034R1
PCB-U007	R3146	C-CARBON R	RN72K1J-390JE	1	435033904R1
PCB-U007	R3147	C-CARBON R	RN72K1J-000JE	1	435030004R1
PCB-U007	R3148	C-CARBON R	RN72K1J-390JE	1	435033904R1
PCB-U007	R3149	C-CARBON R	RN72K1J-102JE	1	435031024R1
PCB-U007	R3150	C-CARBON R	RN72K1J-151JE	1	435031514R1
PCB-U007	R3151	C-CARBON R	RN72K1J-103JE	1	435031034R1
PCB-U007	R3152	C-CARBON R	RN72K1J-103JE	1	435031034R1
PCB-U007	R3154	C-CARBON R	RN72K1J-390JE	1	435033904R1
PCB-U007	R3155	C-CARBON R	RN72K1J-390JE	1	435033904R1
PCB-U007	R3156	C-CARBON R	RN72K1J-390JE	1	435033904R1
PCB-U007	R3157	C-CARBON R	RN72K1J-000JE	1	435030004R1
PCB-U007	R3158	C-CARBON R	RN72K1J-000JE	1	435030004R1
PCB-U007	R3159	C-CARBON R	RN72K1J-000JE	1	435030004R1

PCB-U007	R3160	C-CARBON R	RN72K1J-000JE	1	435030004R1
PCB-U007	R3162	C-CARBON R	RN72K1J-390JE	1	435033904R1
PCB-U007	R3163	C-CARBON R	RN72K1J-220JE	1	435032204R1
PCB-U007	R3164	C-CARBON R	RN72K1J-472JE	1	435034724R1
PCB-U007	R3168	C-CARBON R	RN72K1J-220JE	1	435032204R1
PCB-U007	R3169	C-CARBON R	RN72K1J-220JE	1	435032204R1
PCB-U007	R3170	C-CARBON R	RN72K1J-391FE	1	435033912R1
PCB-U007	R3171	C-CARBON R	RN72K1J-222FE	1	435032222R1
PCB-U007	R3172	C-CARBON R	RN72K1J-392FE	1	435033922R1
PCB-U007	R3173	C-CARBON R	RN72K1J-390JE	1	435033904R1
PCB-U007	R3174	C-CARBON R	RN72K1J-390JE	1	435033904R1
PCB-U007	R3176	C-CARBON R	MCR03EZPF49R9(49.9_1%)	1	4100037R2
PCB-U007	R3177	C-CARBON R	MCR03EZPF49R9(49.9_1%)	1	4100037R2
PCB-U007	R3178	C-CARBON R	MCR03EZPF49R9(49.9_1%)	1	4100037R2
PCB-U007	R3179	C-CARBON R	MCR03EZPF49R9(49.9_1%)	1	4100037R2
PCB-U007	R3180	C-CARBON R	RN72K1J-100FE	1	435031002R1
PCB-U007	R3181	C-CARBON R	RN72K1J-470JE	1	435034704R1
PCB-U007	R3182	C-CARBON R	RN72K1J-472JE	1	435034724R1
PCB-U007	R3183	C-CARBON R	RN72K1J-470JE	1	435034704R1
PCB-U007	R3184	C-CARBON R	RN72K1J-470JE	1	435034704R1
PCB-U007	R3185	C-CARBON R	RN72K1J-392FE	1	435033922R1
PCB-U007	R3186	C-CARBON R	RN72K1J-472JE	1	435034724R1
PCB-U007	R3187	C-CARBON R	RN72K1J-223FE	1	435032232R1
PCB-U007	R3188	C-CARBON R	RN72K1J-224FE	1	435032242R1
PCB-U007	R3189	C-CARBON R	RN72K1J-103FE	1	435031032R1
PCB-U007	R3190	C-CARBON R	RN72K1J-393FE	1	435033932R1
PCB-U007	R3191	C-CARBON R	RN72K1J-105FE	1	435031052R1
PCB-U007	R3192	C-CARBON R	RN72K1J-472JE	1	435034724R1
PCB-U007	R3193	C-CARBON R	RN72K1J-472JE	1	435034724R1
PCB-U007	R3194	C-CARBON R	RN72K1J-472JE	1	435034724R1
PCB-U007	R3199	C-CARBON R	RN72K1J-102JE	1	435031024R1
PCB-U007	R3200	C-CARBON R	RN72K1J-103JE	1	435031034R1
PCB-U007	R3201	C-CARBON R	RN72K1J-103JE	1	435031034R1

PCB-U007	R3202	C-CARBON R	RN72K1J-103JE	1	435031034R1
PCB-U007	R3203	C-CARBON R	RN72K1J-103JE	1	435031034R1
PCB-U007	R3204	C-CARBON R	RN72K1J-103JE	1	435031034R1
PCB-U007	R3205	C-CARBON R	RN72K1J-103JE	1	435031034R1
PCB-U007	R3208	C-CARBON R	RN72K1J-220JE	1	435032204R1
PCB-U007	R3212	C-CARBON R	RN72K1J-220JE	1	435032204R1
PCB-U007	R3215	C-CARBON R	RN72K1J-221JE	1	435032214R1
PCB-U007	R3218	C-CARBON R	RN72K1J-220JE	1	435032204R1
PCB-U007	R3219	C-CARBON R	RN72K1J-221JE	1	435032214R1
PCB-U007	R3221	C-CARBON R	RN72K1J-470JE	1	435034704R1
PCB-U007	R3224	C-CARBON R	RN72K1J-220JE	1	435032204R1
PCB-U007	R3225	C-CARBON R	RN72K1J-220JE	1	435032204R1
PCB-U007	R3226	C-R NET	RM7LJ470X04	1	43484747004R2
PCB-U007	R3227	C-CARBON R	RN72K1J-470JE	1	435034704R1
PCB-U007	R3228	C-CARBON R	RN72K1J-470JE	1	435034704R1
PCB-U007	R3229	C-CARBON R	RN72K1J-470JE	1	435034704R1
PCB-U007	R3230	C-CARBON R	RN72K1J-221JE	1	435032214R1
PCB-U007	R3231	C-CARBON R	RN72K1J-470JE	1	435034704R1
PCB-U007	R3232	C-CARBON R	RN72K1J-221JE	1	435032214R1
PCB-U007	R3233	C-CARBON R	RN72K1J-221JE	1	435032214R1
PCB-U007	R3234	C-CARBON R	RN72K1J-470JE	1	435034704R1
PCB-U007	R3236	C-CARBON R	RN72K1J-470JE	1	435034704R1
PCB-U007	R3237	C-CARBON R	RN72K1J-221JE	1	435032214R1
PCB-U007	R3238	C-CARBON R	RN72K1J-470JE	1	435034704R1
PCB-U007	R3239	C-CARBON R	RN72K1J-221JE	1	435032214R1
PCB-U007	R3240	C-CARBON R	RN72K1J-103JE	1	435031034R1
PCB-U007	R3241	C-CARBON R	RN72K1J-221JE	1	435032214R1
PCB-U007	R3242	C-CARBON R	RN72K1J-221JE	1	435032214R1
PCB-U007	R3243	C-CARBON R	RN72K1J-220JE	1	435032204R1
PCB-U007	R3244	C-CARBON R	RN72K1J-470JE	1	435034704R1
PCB-U007	R3245	C-CARBON R	RN72K1J-103JE	1	435031034R1
PCB-U007	R3246	C-CARBON R	RN72K1J-103JE	1	435031034R1
PCB-U007	R3247	C-CARBON R	RN72K1J-331JE	1	435033314R1



PCB-U007	R3248	C-CARBON R	RN72K1J-220JE	1	435032204R1
PCB-U007	R3249	C-CARBON R	RN72K1J-470JE	1	435034704R1
PCB-U007	R3250	C-CARBON R	RN72K1J-470JE	1	435034704R1
PCB-U007	R3251	C-CARBON R	RN72K1J-470JE	1	435034704R1
PCB-U007	R3252	C-CARBON R	RN72K1J-220JE	1	435032204R1
PCB-U007	R3253	C-CARBON R	RN72K1J-470JE	1	435034704R1
PCB-U007	R3254	C-CARBON R	RN72K1J-470JE	1	435034704R1
PCB-U007	R3255	C-CARBON R	RN72K1J-103JE	1	435031034R1
PCB-U007	R3256	C-CARBON R	RN72K1J-470JE	1	435034704R1
PCB-U007	R3257	C-CARBON R	RN72K1J-470JE	1	435034704R1
PCB-U007	R3259	C-CARBON R	RN72K1J-220JE	1	435032204R1
PCB-U007	R3260	C-CARBON R	RN72K1J-390JE	1	435033904R1
PCB-U007	R3261	C-CARBON R	RN72K1J-470JE	1	435034704R1
PCB-U007	R3262	C-CARBON R	RN72K1J-221JE	1	435032214R1
PCB-U007	R3264	C-CARBON R	RN72K1J-470JE	1	435034704R1
PCB-U007	R3265	C-CARBON R	RN72K1J-390JE	1	435033904R1
PCB-U007	R3267	C-CARBON R	RN72K1J-470JE	1	435034704R1
PCB-U007	R3268	C-CARBON R	RN72K1J-390JE	1	435033904R1
PCB-U007	R3270	C-CARBON R	RN72K1J-470JE	1	435034704R1
PCB-U007	R3271	C-CARBON R	RN72K1J-390JE	1	435033904R1
PCB-U007	R3272	C-CARBON R	RN72K1J-470JE	1	435034704R1
PCB-U007	R3273	C-CARBON R	RN72K1J-470JE	1	435034704R1
PCB-U007	R3274	C-CARBON R	RN72K1J-390JE	1	435033904R1
PCB-U007	R3275	C-CARBON R	RN72K1J-220JE	1	435032204R1
PCB-U007	R3276	C-CARBON R	RN72K1J-470JE	1	435034704R1
PCB-U007	R3277	C-CARBON R	RN72K1J-220JE	1	435032204R1
PCB-U007	R3278	C-CARBON R	RN72K1J-470JE	1	435034704R1
PCB-U007	R3279	C-CARBON R	RN72K1J-470JE	1	435034704R1
PCB-U007	R3280	C-CARBON R	RN72K1J-470JE	1	435034704R1
PCB-U007	R3281	C-CARBON R	RN72K1J-103JE	1	435031034R1
PCB-U007	R3282	C-CARBON R	RN72K1J-103JE	1	435031034R1
PCB-U007	R3283	C-CARBON R	RN72K1J-103JE	1	435031034R1
PCB-U007	R3284	C-CARBON R	RN72K1J-103JE	1	435031034R1

PCB-U007	R3285	C-CARBON R	RN72K1J-103JE	1	435031034R1
PCB-U007	R3286	C-CARBON R	RN72K1J-103JE	1	435031034R1
PCB-U007	R3287	C-CARBON R	RN72K1J-220JE	1	435032204R1
PCB-U007	R3288	C-CARBON R	RN72K1J-223JE	1	435032234R1
PCB-U007	R3289	C-CARBON R	RN72K1J-152JE	1	435031524R1
PCB-U007	R3290	C-CARBON R	RN72K1J-105JE	1	435031054R1
PCB-U007	R3291	C-CARBON R	RN72K1J-105JE	1	435031054R1
PCB-U007	R3292	C-CARBON R	RN72K1J-561FE	1	435035612R1
PCB-U007	R3293	C-CARBON R	RN72K1J-560JE	1	435035604R1
PCB-U007	R3294	C-CARBON R	RN72K1J-561FE	1	435035612R1
PCB-U007	R3295	C-CARBON R	RN72K1J-560JE	1	435035604R1
PCB-U007	R3296	C-CARBON R	RN72K1J-223JE	1	435032234R1
PCB-U007	R3297	C-CARBON R	RN72K1J-332JE	1	435033324R1
PCB-U007	R3298	C-CARBON R	RN72K1J-182JE	1	435031824R1
PCB-U007	R3299	C-CARBON R	RN72K1J-220JE	1	435032204R1
PCB-U007	R3300	C-CARBON R	RN72K1J-153JE	1	435031534R1
PCB-U007	R3301	C-CARBON R	RN72K1J-153JE	1	435031534R1
PCB-U007	R3302	C-CARBON R	RN72K1J-332JE	1	435033324R1
PCB-U007	R3303	C-CARBON R	RN72K1J-104JE	1	435031044R1
PCB-U007	R3304	C-CARBON R	RN72K1J-153JE	1	435031534R1
PCB-U007	R3305	C-CARBON R	RN72K1J-153JE	1	435031534R1
PCB-U007	R3306	C-CARBON R	RN72K1J-332JE	1	435033324R1
PCB-U007	R3307	C-CARBON R	RN72K1J-104JE	1	435031044R1
PCB-U007	R3308	C-CARBON R	RN72K1J-223JE	1	435032234R1
PCB-U007	R3309	C-CARBON R	RN72K1J-332JE	1	435033324R1
PCB-U007	R3310	C-CARBON R	RN72K1J-182JE	1	435031824R1
PCB-U007	R3311	C-CARBON R	RN72K1J-471JE	1	435034714R1
PCB-U007	R3312	C-CARBON R	RN72K1J-223JE	1	435032234R1
PCB-U007	R3313	C-CARBON R	RN72K1J-152JE	1	435031524R1
PCB-U007	R3314	C-CARBON R	RN72K1J-391JE	1	435033914R1
PCB-U007	R3315	C-CARBON R	RN72K1J-560JE	1	435035604R1
PCB-U007	R3401	C-R NET	RM7LJ330X04	1	43484733004R2
PCB-U007	R3402	C-R NET	RM7LJ330X04	1	43484733004R2

PCB-U007	R3403	C-R NET	RM7LJ330X04	1	43484733004R2
PCB-U007	R3404	C-R NET	RM7LJ330X04	1	43484733004R2
PCB-U007	R3405	C-CARBON R	RN72K1J-103JE	1	435031034R1
PCB-U007	R3406	C-CARBON R	RN72K1J-103JE	1	435031034R1
PCB-U007	R3407	C-CARBON R	RN72K1J-103JE	1	435031034R1
PCB-U007	R3408	C-CARBON R	RN72K1J-103JE	1	435031034R1
PCB-U007	R3409	C-CARBON R	RN72K1J-103JE	1	435031034R1
PCB-U007	R3410	C-CARBON R	RN72K1J-471JE	1	435034714R1
PCB-U007	R3411	C-CARBON R	RN72K1J-222JE	1	435032224R1
PCB-U007	R3412	C-CARBON R	RN72K1J-470JE	1	435034704R1
PCB-U007	R3413	C-CARBON R	RN72K1J-470JE	1	435034704R1
PCB-U007	R3414	C-CARBON R	RN72K1J-470JE	1	435034704R1
PCB-U007	R3416	C-CARBON R	RN72K1J-471JE	1	435034714R1
PCB-U007	R3417	C-CARBON R	RN72K1J-330JE	1	435033304R1
PCB-U007	R3418	C-CARBON R	RN72K1J-470JE	1	435034704R1
PCB-U007	R3419	C-CARBON R	RN72K1J-750JE	1	435037504R1
PCB-U007	R3420	C-CARBON R	RN72K1J-470JE	1	435034704R1
PCB-U007	R3421	C-CARBON R	RN72K1J-102JE	1	435031024R1
PCB-U007	R3422	C-CARBON R	RN72K1J-330JE	1	435033304R1
PCB-U007	R3423	C-CARBON R	RN72K1J-470JE	1	435034704R1
PCB-U007	R3424	C-CARBON R	RN72K1J-470JE	1	435034704R1
PCB-U007	R3425	C-CARBON R	RN72K1J-470JE	1	435034704R1
PCB-U007	R3426	C-R NET	RM7LJ330X04	1	43484733004R2
PCB-U007	R3427	C-CARBON R	RN72K1J-470JE	1	435034704R1
PCB-U007	R3428	C-CARBON R	RN72K1J-470JE	1	435034704R1
PCB-U007	R3429	C-R NET	RM7LJ330X04	1	43484733004R2
PCB-U007	R3430	C-R NET	RM7LJ330X04	1	43484733004R2
PCB-U007	R3431	C-CARBON R	RN72K1J-103JE	1	435031034R1
PCB-U007	R3432	C-CARBON R	RN72K1J-103JE	1	435031034R1
PCB-U007	R3433	C-CARBON R	RN72K1J-103JE	1	435031034R1
PCB-U007	R3435	C-R NET	RM7LJ330X04	1	43484733004R2
PCB-U007	R3436	C-CARBON R	RN72K1J-331JE	1	435033314R1
PCB-U007	R3437	C-CARBON R	RN72K1J-331JE	1	435033314R1

PCB-U007	R3438	C-CARBON R	RN72K1J-331JE	1	435033314R1
PCB-U007	R3439	C-R NET	RM7LJ330X04	1	43484733004R2
PCB-U007	R3440	C-CARBON R	RN72K1J-331JE	1	435033314R1
PCB-U007	R3441	C-CARBON R	RN72K1J-331JE	1	435033314R1
PCB-U007	R3442	C-CARBON R	RN72K1J-331JE	1	435033314R1
PCB-U007	R3443	C-CARBON R	RN72K1J-331JE	1	435033314R1
PCB-U007	R3444	C-CARBON R	RN72K1J-331JE	1	435033314R1
PCB-U007	R3445	C-R NET	RM7LJ330X04	1	43484733004R2
PCB-U007	R3446	C-CARBON R	RN72K1J-470JE	1	435034704R1
PCB-U007	R3447	C-CARBON R	RN72K1J-470JE	1	435034704R1
PCB-U007	R3448	C-CARBON R	RN72K1J-470JE	1	435034704R1
PCB-U007	R3449	C-CARBON R	RN72K1J-470JE	1	435034704R1
PCB-U007	R3450	C-CARBON R	RN72K1J-470JE	1	435034704R1
PCB-U007	R3451	C-CARBON R	RN72K1J-103JE	1	435031034R1
PCB-U007	R3452	C-CARBON R	RN72K1J-103JE	1	435031034R1
PCB-U007	R3453	C-CARBON R	RN72K1J-103JE	1	435031034R1
PCB-U007	R3454	C-CARBON R	RN72K1J-470JE	1	435034704R1
PCB-U007	R3455	C-CARBON R	RN72K1J-103JE	1	435031034R1
PCB-U007	R3456	C-CARBON R	RN72K1J-470JE	1	435034704R1
PCB-U007	R3457	C-CARBON R	RN72K1J-470JE	1	435034704R1
PCB-U007	R3458	C-CARBON R	RN72K1J-470JE	1	435034704R1
PCB-U007	R3459	C-CARBON R	RN72K1J-470JE	1	435034704R1
PCB-U007	R3460	C-CARBON R	RN72K1J-470JE	1	435034704R1
PCB-U007	R3461	C-CARBON R	RN72K1J-470JE	1	435034704R1
PCB-U007	R3462	C-CARBON R	RN72K1J-470JE	1	435034704R1
PCB-U007	R3464	C-CARBON R	RN72K1J-102JE	1	435031024R1
PCB-U007	R3465	C-CARBON R	RN72K1J-223FE	1	435032232R1
PCB-U007	R3466	C-CARBON R	RN72K1J-392FE	1	435033922R1
PCB-U007	R3467	C-CARBON R	RN72K1J-224FE	1	435032242R1
PCB-U007	R3468	C-CARBON R	RN72K1J-103FE	1	435031032R1
PCB-U007	R3469	C-CARBON R	RN72K1J-333FE	1	435033332R1
PCB-U007	R3470	C-CARBON R	RN72K1J-391JE	1	435033914R1
PCB-U007	R3471	C-CARBON R	RN72K1J-391JE	1	435033914R1

PCB-U007	R3472	C-CARBON R	RN72K1J-105JE	1	435031054R1
PCB-U007	R3473	C-CARBON R	RN72K1J-000JE	1	435030004R1
PCB-U007	R3501	C-R NET	RM7LJ330X04	1	43484733004R2
PCB-U007	R3502	C-R NET	RM7LJ330X04	1	43484733004R2
PCB-U007	R3503	C-R NET	RM7LJ330X04	1	43484733004R2
PCB-U007	R3504	C-R NET	RM7LJ330X04	1	43484733004R2
PCB-U007	R3505	C-CARBON R	RN72K1J-103JE	1	435031034R1
PCB-U007	R3506	C-CARBON R	RN72K1J-103JE	1	435031034R1
PCB-U007	R3507	C-CARBON R	RN72K1J-103JE	1	435031034R1
PCB-U007	R3508	C-CARBON R	RN72K1J-103JE	1	435031034R1
PCB-U007	R3509	C-CARBON R	RN72K1J-103JE	1	435031034R1
PCB-U007	R3510	C-CARBON R	RN72K1J-471JE	1	435034714R1
PCB-U007	R3511	C-CARBON R	RN72K1J-222JE	1	435032224R1
PCB-U007	R3512	C-CARBON R	RN72K1J-470JE	1	435034704R1
PCB-U007	R3513	C-CARBON R	RN72K1J-470JE	1	435034704R1
PCB-U007	R3514	C-CARBON R	RN72K1J-470JE	1	435034704R1
PCB-U007	R3516	C-CARBON R	RN72K1J-471JE	1	435034714R1
PCB-U007	R3517	C-CARBON R	RN72K1J-330JE	1	435033304R1
PCB-U007	R3518	C-CARBON R	RN72K1J-470JE	1	435034704R1
PCB-U007	R3519	C-CARBON R	RN72K1J-750JE	1	435037504R1
PCB-U007	R3520	C-CARBON R	RN72K1J-470JE	1	435034704R1
PCB-U007	R3521	C-CARBON R	RN72K1J-471JE	1	435034714R1
PCB-U007	R3522	C-CARBON R	RN72K1J-330JE	1	435033304R1
PCB-U007	R3523	C-CARBON R	RN72K1J-470JE	1	435034704R1
PCB-U007	R3524	C-CARBON R	RN72K1J-470JE	1	435034704R1
PCB-U007	R3525	C-CARBON R	RN72K1J-470JE	1	435034704R1
PCB-U007	R3526	C-R NET	RM7LJ330X04	1	43484733004R2
PCB-U007	R3527	C-CARBON R	RN72K1J-470JE	1	435034704R1
PCB-U007	R3528	C-CARBON R	RN72K1J-470JE	1	435034704R1
PCB-U007	R3529	C-R NET	RM7LJ330X04	1	43484733004R2
PCB-U007	R3530	C-R NET	RM7LJ330X04	1	43484733004R2
PCB-U007	R3531	C-CARBON R	RN72K1J-103JE	1	435031034R1
PCB-U007	R3532	C-CARBON R	RN72K1J-103JE	1	435031034R1

PCB-U007	R3533	C-CARBON R	RN72K1J-103JE	1	435031034R1
PCB-U007	R3534	C-CARBON R	RN72K1J-331JE	1	435033314R1
PCB-U007	R3535	C-R NET	RM7LJ330X04	1	43484733004R2
PCB-U007	R3536	C-CARBON R	RN72K1J-331JE	1	435033314R1
PCB-U007	R3537	C-CARBON R	RN72K1J-331JE	1	435033314R1
PCB-U007	R3538	C-CARBON R	RN72K1J-331JE	1	435033314R1
PCB-U007	R3539	C-R NET	RM7LJ330X04	1	43484733004R2
PCB-U007	R3540	C-CARBON R	RN72K1J-331JE	1	435033314R1
PCB-U007	R3541	C-CARBON R	RN72K1J-331JE	1	435033314R1
PCB-U007	R3542	C-CARBON R	RN72K1J-331JE	1	435033314R1
PCB-U007	R3543	C-CARBON R	RN72K1J-331JE	1	435033314R1
PCB-U007	R3544	C-CARBON R	RN72K1J-331JE	1	435033314R1
PCB-U007	R3545	C-R NET	RM7LJ330X04	1	43484733004R2
PCB-U007	R3546	C-CARBON R	RN72K1J-470JE	1	435034704R1
PCB-U007	R3547	C-CARBON R	RN72K1J-470JE	1	435034704R1
PCB-U007	R3548	C-CARBON R	RN72K1J-470JE	1	435034704R1
PCB-U007	R3549	C-CARBON R	RN72K1J-470JE	1	435034704R1
PCB-U007	R3550	C-CARBON R	RN72K1J-470JE	1	435034704R1
PCB-U007	R3551	C-CARBON R	RN72K1J-103JE	1	435031034R1
PCB-U007	R3552	C-CARBON R	RN72K1J-103JE	1	435031034R1
PCB-U007	R3553	C-CARBON R	RN72K1J-103JE	1	435031034R1
PCB-U007	R3554	C-CARBON R	RN72K1J-470JE	1	435034704R1
PCB-U007	R3555	C-CARBON R	RN72K1J-103JE	1	435031034R1
PCB-U007	R3556	C-CARBON R	RN72K1J-470JE	1	435034704R1
PCB-U007	R3557	C-CARBON R	RN72K1J-470JE	1	435034704R1
PCB-U007	R3558	C-CARBON R	RN72K1J-470JE	1	435034704R1
PCB-U007	R3559	C-CARBON R	RN72K1J-470JE	1	435034704R1
PCB-U007	R3560	C-CARBON R	RN72K1J-470JE	1	435034704R1
PCB-U007	R3561	C-CARBON R	RN72K1J-470JE	1	435034704R1
PCB-U007	R3562	C-CARBON R	RN72K1J-470JE	1	435034704R1
PCB-U007	R3564	C-CARBON R	RN72K1J-102JE	1	435031024R1
PCB-U007	R3565	C-CARBON R	RN72K1J-223FE	1	435032232R1
PCB-U007	R3566	C-CARBON R	RN72K1J-392FE	1	435033922R1

PCB-U007	R3567	C-CARBON R	RN72K1J-224FE	1	435032242R1
PCB-U007	R3568	C-CARBON R	RN72K1J-103FE	1	435031032R1
PCB-U007	R3569	C-CARBON R	RN72K1J-333FE	1	435033332R1
PCB-U007	R3670	C-CARBON R	RN72K1J-103JE	1	435031034R1
PCB-U007	R3671	C-CARBON R	RN72K1J-000JE	1	435030004R1
PCB-U007	R3673	C-CARBON R	RN72K1J-000JE	1	435030004R1
PCB-U007	R3674	C-CARBON R	RN72K1J-000JE	1	435030004R1
PCB-U007	R3680	C-CARBON R	RN72K1J-000JE	1	435030004R1
PCB-U007	R8040	C-CARBON R	RN72K1J-000JE	1	435030004R1
PCB-U007	R8041	C-CARBON R	RN72K1J-000JE	1	435030004R1
PCB-U007	R8042	C-CARBON R	RN72K1J-000JE	1	435030004R1
PCB-U007	R8043	C-CARBON R	RN72K1J-750JE	1	435037504R1
PCB-U007	R8044	C-CARBON R	RN72K1J-750JE	1	435037504R1
PCB-U007	R8045	C-CARBON R	RN72K1J-750JE	1	435037504R1
PCB-U007	R8046	C-CARBON R	RN72K1J-750JE	1	435037504R1
PCB-U007	R8047	C-CARBON R	RN72K1J-750JE	1	435037504R1
PCB-U007	R8048	C-CARBON R	RN72K1J-750JE	1	435037504R1
PCB-U007	R8049	C-CARBON R	RN72K1J-750JE	1	435037504R1
PCB-U007	R8050	C-CARBON R	RN72K1J-750JE	1	435037504R1
PCB-U007	R8051	C-CARBON R	RN72K1J-750JE	1	435037504R1
PCB-U007	R8052	C-CARBON R	RN72K1J-750JE	1	435037504R1
PCB-U007	R8053	C-CARBON R	RN72K1J-750JE	1	435037504R1
PCB-U007	R8054	C-CARBON R	RN72K1J-272JE	1	435032724R1
PCB-U007	R8055	C-CARBON R	RN72K1J-272JE	1	435032724R1
PCB-U007	R8056	C-CARBON R	RN72K1J-101JE	1	435031014R1
PCB-U007	R8057	C-CARBON R	RN72K1J-101JE	1	435031014R1
PCB-U007	R8058	C-CARBON R	RN72K1J-562JE	1	435035624R1
PCB-U007	R8059	C-CARBON R	RN72K1J-101JE	1	435031014R1
PCB-U007	R8060	C-CARBON R	RN72K1J-101JE	1	435031014R1
PCB-U007	R8061	C-CARBON R	RN72K1J-101JE	1	435031014R1
PCB-U007	R8062	C-CARBON R	RN72K1J-101JE	1	435031014R1
PCB-U007	R8063	C-CARBON R	RN72K1J-273JE	1	435032734R1
PCB-U007	R8064	C-CARBON R	RN72K1J-391JE	1	435033914R1

PCB-U007	R8068	C-CARBON R	RN72K1J-750JE	1	435037504R1
PCB-U007	R8069	C-CARBON R	RN72K1J-750JE	1	435037504R1
PCB-U007	R8070	C-CARBON R	RN72K1J-750JE	1	435037504R1
PCB-U007	R8071	C-CARBON R	RN72K1J-750JE	1	435037504R1
PCB-U007	R8072	C-CARBON R	RN72K1J-750JE	1	435037504R1
PCB-U007	R8073	C-CARBON R	RN72K1J-750JE	1	435037504R1
PCB-U007	R8075	C-CARBON R	RN72K1J-472JE	1	435034724R1
PCB-U007	R8081	C-R NET	RM7LJ330X04	1	43484733004R2
PCB-U007	R8082	C-R NET	RM7LJ330X04	1	43484733004R2
PCB-U007	R8083	C-R NET	RM7LJ330X04	1	43484733004R2
PCB-U007	R8084	C-R NET	RM7LJ330X04	1	43484733004R2
PCB-U007	R8085	C-R NET	RM7LJ330X04	1	43484733004R2
PCB-U007	R8086	C-R NET	RM7LJ330X04	1	43484733004R2
PCB-U007	R8087	C-R NET	RM7LJ330X04	1	43484733004R2
PCB-U007	R8088	C-R NET	RM7LJ330X04	1	43484733004R2
PCB-U007	R8089	C-CARBON R	RN72K1J-220JE	1	435032204R1
PCB-U007	R8090	C-R NET	RM7LJ330X04	1	43484733004R2
PCB-U007	R8091	C-R NET	RM7LJ220X04	1	43484722004R2
PCB-U007	R8092	C-R NET	RM7LJ220X04	1	43484722004R2
PCB-U007	R8093	C-R NET	RM7LJ220X04	1	43484722004R2
PCB-U007	R8094	C-R NET	RM7LJ220X04	1	43484722004R2
PCB-U007	R8095	C-R NET	RM7LJ220X04	1	43484722004R2
PCB-U007	R8096	C-R NET	RM7LJ220X04	1	43484722004R2
PCB-U007	R8097	C-R NET	RM7LJ220X04	1	43484722004R2
PCB-U007	R8098	C-R NET	RM7LJ220X04	1	43484722004R2
PCB-U007	R8099	C-R NET	RM7LJ220X04	1	43484722004R2
PCB-U007	R8100	C-R NET	RM7LJ220X04	1	43484722004R2
PCB-U007	R8101	C-R NET	RM7LJ220X04	1	43484722004R2
PCB-U007	R8102	C-CARBON R	RN72K1J-105JE	1	435031054R1
PCB-U007	R8103	C-CARBON R	RN72K1J-561JE	1	435035614R1
PCB-U007	R8104	C-CARBON R	RN72K1J-000JE	1	435030004R1
PCB-U007	R8110	C-CARBON R	RN72K1J-182JE	1	435031824R1
PCB-U007	R8111	C-CARBON R	RN72K1J-271JE	1	435032714R1



PCB-U007	R8123	C-CARBON R	RN72K1J-000JE	1	435030004R1
PCB-U007	R8124	C-CARBON R	RN72K1J-103JE	1	435031034R1
PCB-U007	R8125	C-CARBON R	RN72K1J-103JE	1	435031034R1
PCB-U007	R8126	C-CARBON R	RN72K1J-271JE	1	435032714R1
PCB-U007	R8127	C-CARBON R	RN72K1J-103JE	1	435031034R1
PCB-U007	R8128	C-CARBON R	RN72K1J-750JE	1	435037504R1
PCB-U007	R8129	C-CARBON R	RN72K1J-103JE	1	435031034R1
PCB-U007	R8130	C-CARBON R	RN72K1J-750JE	1	435037504R1
PCB-U007	R8144	C-CARBON R	RN72K1J-103JE	1	435031034R1
PCB-U007	R8147	C-CARBON R	RN72K1J-103JE	1	435031034R1
PCB-U007	R8149	C-CARBON R	RN72K1J-103JE	1	435031034R1
PCB-U007	R8150	C-CARBON R	RN72K1J-103JE	1	435031034R1
PCB-U007	R8151	C-CARBON R	RN72K1J-103JE	1	435031034R1
PCB-U007	R8154	C-CARBON R	RN72K1J-000JE	1	435030004R1
PCB-U007	R8157	C-CARBON R	RN72K1J-103JE	1	435031034R1
PCB-U007	R8158	C-CARBON R	RN72K1J-103JE	1	435031034R1
PCB-U007	R8160	C-CARBON R	RN72K1J-332JE	1	435033324R1
PCB-U007	R8161	C-CARBON R	RN72K1J-681JE	1	435036814R1
PCB-U007	R8162	C-CARBON R	RN72K1J-101JE	1	435031014R1
PCB-U007	R8165	C-CARBON R	RN72K1J-103JE	1	435031034R1
PCB-U007	R8202	C-CARBON R	RN72K1J-000JE	1	435030004R1
PCB-U007	R8203	C-CARBON R	RN72K1J-000JE	1	435030004R1
PCB-U007	R8205	C-CARBON R	RN72K1J-330JE	1	435033304R1
PCB-U007	R8206	C-CARBON R	RN72K1J-103JE	1	435031034R1
PCB-U007	R8207	C-CARBON R	RN72K1J-103JE	1	435031034R1
PCB-U007	R8210	C-CARBON R	RN72K1J-470JE	1	435034704R1
PCB-U007	R8211	C-CARBON R	RN72K1J-101JE	1	435031014R1
PCB-U007	R8212	C-CARBON R	RN72K1J-101JE	1	435031014R1
PCB-U007	R8213	C-CARBON R	RN72K1J-103JE	1	435031034R1
PCB-U007	R8214	C-CARBON R	RN72K1J-101JE	1	435031014R1
PCB-U007	R8215	C-CARBON R	RN72K1J-101JE	1	435031014R1
PCB-U007	R8216	C-CARBON R	RN72K1J-103JE	1	435031034R1
PCB-U007	R8218	C-CARBON R	RN72K1J-103JE	1	435031034R1

PCB-U007	R8219	C-CARBON R	RN72K1J-332JE	1	435033324R1
PCB-U007	R8221	C-CARBON R	RN72K1J-331JE	1	435033314R1
PCB-U007	R8222	C-CARBON R	RN72K2B-000JE	1	433220004R1
PCB-U007	R8223	C-CARBON R	RN72K1J-000JE	1	435030004R1
PCB-U007	R8224	C-CARBON R	RN72K1J-000JE	1	435030004R1
PCB-U007	R8231	C-CARBON R	RN72K1J-332JE	1	435033324R1
PCB-U007	R8232	C-CARBON R	RN72K1J-332JE	1	435033324R1
PCB-U007	R8233	C-CARBON R	RN72K1J-332JE	1	435033324R1
PCB-U007	R8234	C-CARBON R	RN72K1J-332JE	1	435033324R1
PCB-U007	R8236	C-CARBON R	RN72K1J-331JE	1	435033314R1
PCB-U007	R8240	C-CARBON R	RN72K1J-331JE	1	435033314R1
PCB-U007	R8241	C-CARBON R	RN72K1J-331JE	1	435033314R1
PCB-U007	R8243	C-CARBON R	RN72K1J-470JE	1	435034704R1
PCB-U007	R8255	C-CARBON R	RN72K1J-222JE	1	435032224R1
PCB-U007	R8256	C-CARBON R	RN72K1J-105JE	1	435031054R1
PCB-U007	R8263	C-CARBON R	RN72K1J-472JE	1	435034724R1
PCB-U007	R8264	C-CARBON R	RN72K1J-331JE	1	435033314R1
PCB-U007	R8265	C-CARBON R	RN72K1J-330JE	1	435033304R1
PCB-U007	R8313	C-CARBON R	RN72K1J-103JE	1	435031034R1
PCB-U007	R8319	C-CARBON R	RN72K1J-473JE	1	435034734R1
PCB-U007	R8320	C-CARBON R	RN72K1J-473JE	1	435034734R1
PCB-U007	R8323	C-CARBON R	RN72K1J-103JE	1	435031034R1
PCB-U007	R8329	C-CARBON R	RN72K1J-473JE	1	435034734R1
PCB-U007	R8330	C-CARBON R	RN72K1J-473JE	1	435034734R1
PCB-U007	R8333	C-CARBON R	RN72K1J-103JE	1	435031034R1
PCB-U007	R8334	C-CARBON R	RN72K1J-222JE	1	435032224R1
PCB-U007	R8335	C-CARBON R	RN72K1J-222JE	1	435032224R1
PCB-U007	R8336	C-CARBON R	RN72K1J-472JE	1	435034724R1
PCB-U007	R8337	C-CARBON R	RN72K1J-473JE	1	435034734R1
PCB-U007	R8338	C-CARBON R	RN72K1J-473JE	1	435034734R1
PCB-U007	R8339	C-CARBON R	RN72K2E-470JE	1	435224704R1
PCB-U007	R8343	C-CARBON R	RN72K1J-103JE	1	435031034R1
PCB-U007	R8349	C-CARBON R	RN72K1J-473JE	1	435034734R1

PCB-U007	R8350	C-CARBON R	RN72K1J-473JE	1	435034734R1
PCB-U007	R8360	C-CARBON R	RN72K1J-103JE	1	435031034R1
PCB-U007	R8361	C-CARBON R	RN72K1J-681JE	1	435036814R1
PCB-U007	R8362	C-CARBON R	RN72K1J-101JE	1	435031014R1
PCB-U007	R8365	C-CARBON R	RN72K1J-103JE	1	435031034R1
PCB-U007	R8372	C-CARBON R	RN72K1J-103JE	1	435031034R1
PCB-U007	R8374	C-CARBON R	RN72K1J-472JE	1	435034724R1
PCB-U007	R8375	C-CARBON R	RN72K1J-473JE	1	435034734R1
PCB-U007	R8376	C-CARBON R	RN72K1J-473JE	1	435034734R1
PCB-U007	R8384	C-CARBON R	RN72K1J-222JE	1	435032224R1
PCB-U007	R8385	C-CARBON R	RN72K1J-222JE	1	435032224R1
PCB-U007	R8391	C-CARBON R	RN72K2E-470JE	1	435224704R1
PCB-U007	R8401	C-R NET	RM7LJ220X04	1	43484722004R2
PCB-U007	R8402	C-CARBON R	RN72K1J-220JE	1	435032204R1
PCB-U007	R8403	C-R NET	RM7LJ220X04	1	43484722004R2
PCB-U007	R8404	C-CARBON R	RN72K1J-220JE	1	435032204R1
PCB-U007	R8405	C-CARBON R	RN72K1J-220JE	1	435032204R1
PCB-U007	R8408	C-CARBON R	RN72K1J-220JE	1	435032204R1
PCB-U007	R8409	C-CARBON R	RN72K1J-101JE	1	435031014R1
PCB-U007	R8410	C-CARBON R	RN72K1J-681JE	1	435036814R1
PCB-U007	R8411	C-CARBON R	RN72K1J-472JE	1	435034724R1
PCB-U007	R8416	C-R NET	RM7LJ220X04	1	43484722004R2
PCB-U007	R8417	C-R NET	RM7LJ220X04	1	43484722004R2
PCB-U007	R8418	C-R NET	RM7LJ220X04	1	43484722004R2
PCB-U007	R8419	C-R NET	RM7LJ220X04	1	43484722004R2
PCB-U007	R8420	C-R NET	RM7LJ220X04	1	43484722004R2
PCB-U007	R8421	C-R NET	RM7LJ220X04	1	43484722004R2
PCB-U007	R8422	C-R NET	RM7LJ220X04	1	43484722004R2
PCB-U007	R8423	C-R NET	RM7LJ220X04	1	43484722004R2
PCB-U007	R8424	C-R NET	RM7LJ220X04	1	43484722004R2
PCB-U007	R8425	C-CARBON R	RN72K1J-220JE	1	435032204R1
PCB-U007	R8429	C-CARBON R	RN72K1J-220JE	1	435032204R1
PCB-U007	R8431	C-CARBON R	RN72K1J-472JE	1	435034724R1

PCB-U007	R8432	C-CARBON R	RN72K1J-220JE	1	435032204R1
PCB-U007	R8442	C-CARBON R	RN72K1J-102JE	1	435031024R1
PCB-U007	R8451	C-R NET	RM7LJ220X04	1	43484722004R2
PCB-U007	R8452	C-CARBON R	RN72K1J-220JE	1	435032204R1
PCB-U007	R8453	C-R NET	RM7LJ220X04	1	43484722004R2
PCB-U007	R8454	C-CARBON R	RN72K1J-220JE	1	435032204R1
PCB-U007	R8455	C-CARBON R	RN72K1J-220JE	1	435032204R1
PCB-U007	R8458	C-CARBON R	RN72K1J-220JE	1	435032204R1
PCB-U007	R8459	C-CARBON R	RN72K1J-101JE	1	435031014R1
PCB-U007	R8460	C-CARBON R	RN72K1J-681JE	1	435036814R1
PCB-U007	R8462	C-CARBON R	RN72K1J-472JE	1	435034724R1
PCB-U007	R8466	C-R NET	RM7LJ220X04	1	43484722004R2
PCB-U007	R8467	C-R NET	RM7LJ220X04	1	43484722004R2
PCB-U007	R8468	C-R NET	RM7LJ220X04	1	43484722004R2
PCB-U007	R8469	C-R NET	RM7LJ220X04	1	43484722004R2
PCB-U007	R8470	C-R NET	RM7LJ220X04	1	43484722004R2
PCB-U007	R8471	C-R NET	RM7LJ220X04	1	43484722004R2
PCB-U007	R8472	C-R NET	RM7LJ220X04	1	43484722004R2
PCB-U007	R8473	C-R NET	RM7LJ220X04	1	43484722004R2
PCB-U007	R8474	C-R NET	RM7LJ220X04	1	43484722004R2
PCB-U007	R8475	C-CARBON R	RN72K1J-220JE	1	435032204R1
PCB-U007	R8479	C-CARBON R	RN72K1J-220JE	1	435032204R1
PCB-U007	R8481	C-CARBON R	RN72K1J-472JE	1	435034724R1
PCB-U007	R8482	C-CARBON R	RN72K1J-220JE	1	435032204R1
PCB-U007	R8492	C-CARBON R	RN72K1J-102JE	1	435031024R1
PCB-U007	R8501	C-CARBON R	RN72K1J-330JE	1	435033304R1
PCB-U007	R8502	C-CARBON R	RN72K1J-120JE	1	435031204R1
PCB-U007	R8503	C-R NET	RM7LJ330X04	1	43484733004R2
PCB-U007	R8504	C-R NET	RM7LJ330X04	1	43484733004R2
PCB-U007	R8505	C-R NET	RM7LJ330X04	1	43484733004R2
PCB-U007	R8507	C-R NET	RM7LJ330X04	1	43484733004R2
PCB-U007	R8508	C-R NET	RM7LJ330X04	1	43484733004R2
PCB-U007	R8509	C-R NET	RM7LJ330X04	1	43484733004R2

PCB-U007	R8510	C-R NET	RM7LJ330X04	1	43484733004R2
PCB-U007	R8511	C-R NET	RM7LJ330X04	1	43484733004R2
PCB-U007	R8512	C-R NET	RM7LJ330X04	1	43484733004R2
PCB-U007	R8513	C-R NET	RM7LJ330X04	1	43484733004R2
PCB-U007	R8516	C-CARBON R	RN72K1J-101JE	1	435031014R1
PCB-U007	R8517	C-CARBON R	RN72K1J-101JE	1	435031014R1
PCB-U007	R8518	C-CARBON R	RN72K1J-472JE	1	435034724R1
PCB-U007	R8519	C-CARBON R	RN72K1J-220JE	1	435032204R1
PCB-U007	R8522	C-R NET	RM7LJ330X04	1	43484733004R2
PCB-U007	R8523	C-CARBON R	RN72K1J-330JE	1	435033304R1
PCB-U007	R8524	C-CARBON R	RN72K1J-330JE	1	435033304R1
PCB-U007	R8525	C-CARBON R	RN72K1J-472JE	1	435034724R1
PCB-U007	R8526	C-CARBON R	RN72K1J-472JE	1	435034724R1
PCB-U007	R8527	C-CARBON R	RN72K1J-562JE	1	435035624R1
PCB-U007	R8528	C-CARBON R	RN72K1J-562JE	1	435035624R1
PCB-U007	R8529	C-CARBON R	RN72K1J-103JE	1	435031034R1
PCB-U007	R8531	C-CARBON R	RN72K1J-000JE	1	435030004R1
PCB-U007	R8533	C-CARBON R	RN72K1J-562JE	1	435035624R1
PCB-U007	R8534	C-CARBON R	RN72K1J-562JE	1	435035624R1
PCB-U007	R8535	C-CARBON R	RN72K1J-000JE	1	435030004R1
PCB-U007	R8536	C-CARBON R	RN72K1J-000JE	1	435030004R1
PCB-U007	R8601	C-CARBON R	RN72K1J-000JE	1	435030004R1
PCB-U007	R8602	C-CARBON R	RN72K1J-000JE	1	435030004R1
PCB-U007	R8607	C-CARBON R	RN72K1J-473JE	1	435034734R1
PCB-U007	R8608	C-CARBON R	RN72K1J-473JE	1	435034734R1
PCB-U007	R8609	C-CARBON R	RN72K1J-000JE	1	435030004R1
PCB-U007	R8617	C-CARBON R	RN72K1J-473JE	1	435034734R1
PCB-U007	R8618	C-CARBON R	RN72K1J-473JE	1	435034734R1
PCB-U007	R8619	C-CARBON R	RN72K1J-103JE	1	435031034R1
PCB-U007	R8627	C-CARBON R	RN72K1J-473JE	1	435034734R1
PCB-U007	R8628	C-CARBON R	RN72K1J-473JE	1	435034734R1
PCB-U007	R8629	C-CARBON R	RN72K1J-103JE	1	435031034R1
PCB-U007	R8637	C-CARBON R	RN72K1J-473JE	1	435034734R1

PCB-U007	R8638	C-CARBON R	RN72K1J-473JE	1	435034734R1
PCB-U007	R8639	C-CARBON R	RN72K1J-103JE	1	435031034R1
PCB-U007	R8647	C-CARBON R	RN72K1J-472JE	1	435034724R1
PCB-U007	R8648	C-CARBON R	RN72K1J-472JE	1	435034724R1
PCB-U007	R8649	C-CARBON R	RN72K1J-000JE	1	435030004R1
PCB-U007	R8650	C-CERA C	CK725B1H-102K1	1	332101025R1
PCB-U007	R8651	C-CERA C	CK725B1H-102K1	1	332101025R1
PCB-U007	R8654	C-CARBON R	RN72K1J-223JE	1	435032234R1
PCB-U007	R8655	C-CARBON R	RN72K1J-224JE	1	435032244R1
PCB-U007	R8656	C-CARBON R	RN72K1J-333JE	1	435033334R1
PCB-U007	R8701	C-CARBON R	RN72K1J-103JE	1	435031034R1
PCB-U007	R8702	C-CARBON R	RN72K1J-103JE	1	435031034R1
PCB-U007	R8703	C-CARBON R	RN72K1J-103JE	1	435031034R1
PCB-U007	R8705	C-CARBON R	RN72K1J-220JE	1	435032204R1
PCB-U007	R8706	C-CARBON R	RN72K1J-220JE	1	435032204R1
PCB-U007	R8707	C-CARBON R	RN72K1J-220JE	1	435032204R1
PCB-U007	R8708	C-CARBON R	RN72K1J-103JE	1	435031034R1
PCB-U007	R8709	C-CARBON R	RN72K1J-103JE	1	435031034R1
PCB-U007	R8710	C-CARBON R	RN72K1J-103JE	1	435031034R1
PCB-U007	R8711	C-CARBON R	RN72K1J-222JE	1	435032224R1
PCB-U007	R8712	C-R NET	RM7LJ222X04	1	43484722204R2
PCB-U007	R8713	C-R NET	RM7LJ222X04	1	43484722204R2
PCB-U007	R8714	C-R NET	RM7LJ222X04	1	43484722204R2
PCB-U007	R8715	C-R NET	RM7LJ103X04	1	43484710304R2
PCB-U007	R8716	C-CARBON R	RN72K1J-103JE	1	435031034R1
PCB-U007	R8717	C-CARBON R	RN72K1J-103JE	1	435031034R1
PCB-U007	R8718	C-CARBON R	RN72K1J-220JE	1	435032204R1
PCB-U007	R8719	C-CARBON R	RN72K1J-103JE	1	435031034R1
PCB-U007	R8720	C-CARBON R	RN72K1J-220JE	1	435032204R1
PCB-U007	R8721	C-CARBON R	RN72K1J-220JE	1	435032204R1
PCB-U007	R8722	C-CARBON R	RN72K1J-103JE	1	435031034R1
PCB-U007	R8723	C-CARBON R	RN72K1J-103JE	1	435031034R1
PCB-U007	R8733	C-CARBON R	RN72K1J-103JE	1	435031034R1

PCB-U007	R8737	C-R NET	RM7LJ103X04	1	43484710304R2
PCB-U007	R8738	C-CARBON R	RN72K1J-103JE	1	435031034R1
PCB-U007	R8742	C-CARBON R	RN72K1J-103JE	1	435031034R1
PCB-U007	R8744	C-CARBON R	RN72K1J-103JE	1	435031034R1
PCB-U007	R8745	C-CARBON R	RN72K1J-103JE	1	435031034R1
PCB-U007	R8748	C-CARBON R	RN72K1J-103JE	1	435031034R1
PCB-U007	R8749	C-CARBON R	RN72K1J-220JE	1	435032204R1
PCB-U007	R8750	C-CARBON R	RN72K1J-000JE	1	435030004R1
PCB-U007	R8751	C-CARBON R	RN72K1J-000JE	1	435030004R1
PCB-U007	R8752	C-CARBON R	RN72K1J-000JE	1	435030004R1
PCB-U007	R8801	C-R NET	RM7LJ220X04	1	43484722004R2
PCB-U007	R8802	C-R NET	RM7LJ220X04	1	43484722004R2
PCB-U007	R8803	C-R NET	RM7LJ220X04	1	43484722004R2
PCB-U007	R8804	C-R NET	RM7LJ220X04	1	43484722004R2
PCB-U007	R8805	C-R NET	RM7LJ220X04	1	43484722004R2
PCB-U007	R8806	C-CARBON R	RN72K1J-103JE	1	435031034R1
PCB-U007	R8810	C-R NET	RM7LJ220X04	1	43484722004R2
PCB-U007	R8811	C-R NET	RM7LJ220X04	1	43484722004R2
PCB-U007	R8812	C-R NET	RM7LJ220X04	1	43484722004R2
PCB-U007	R8813	C-CARBON R	RN72K1J-220JE	1	435032204R1
PCB-U007	R8814	C-CARBON R	RN72K1J-181JE	1	435031814R1
PCB-U007	R8815	C-CARBON R	RN72K1J-332JE	1	435033324R1
PCB-U007	R8816	C-CARBON R	RN72K1J-181JE	1	435031814R1
PCB-U007	R8817	C-CARBON R	RN72K1J-332JE	1	435033324R1
PCB-U007	R8818	C-CARBON R	RN72K1J-332JE	1	435033324R1
PCB-U007	R8819	C-CARBON R	RN72K1J-821JE	1	435038214R1
PCB-U007	R8820	C-CARBON R	RN72K1J-332JE	1	435033324R1
PCB-U007	R8821	C-CARBON R	RN72K1J-821JE	1	435038214R1
PCB-U007	R8822	C-CARBON R	RN72K1J-473JE	1	435034734R1
PCB-U007	R8823	C-CARBON R	RN72K1J-000JE	1	435030004R1
PCB-U007	R8824	C-CARBON R	RN72K1J-000JE	1	435030004R1
PCB-U007	R8825	C-CARBON R	RN72K1J-000JE	1	435030004R1
PCB-U007	R8826	C-CARBON R	RN72K1J-000JE	1	435030004R1

PCB-U007	R8827	C-CARBON R	RN72K1J-000JE	1	435030004R1
PCB-U007	R8882	C-CARBON R	RN72K1J-000JE	1	435030004R1
PCB-U007	R8883	C-CARBON R	RN72K1J-000JE	1	435030004R1
PCB-U007	R8901	C-CARBON R	RN72K1J-122JE	1	435031224R1
PCB-U007	R8902	C-CARBON R	RN72K1J-122JE	1	435031224R1
PCB-U007	R8903	C-CARBON R	RN72K1J-122JE	1	435031224R1
PCB-U007	R8904	C-CARBON R	RN72K1J-122JE	1	435031224R1
PCB-U007	R8905	C-CARBON R	RN72K1J-122JE	1	435031224R1
PCB-U007	R8906	C-CARBON R	RN72K1J-122JE	1	435031224R1
PCB-U007	R8907	C-CARBON R	RN72K1J-122JE	1	435031224R1
PCB-U007	R8908	C-CARBON R	RN72K1J-122JE	1	435031224R1
PCB-U007	R8909	C-CARBON R	RN72K1J-122JE	1	435031224R1
PCB-U007	R8910	C-CARBON R	RN72K1J-122JE	1	435031224R1
PCB-U007	R8911	C-CARBON R	RN72K1J-122JE	1	435031224R1
PCB-U007	R8912	C-CARBON R	RN72K1J-122JE	1	435031224R1
PCB-U007	R8913	C-CARBON R	RN72K1J-122JE	1	435031224R1
PCB-U007	R8914	C-CARBON R	RN72K1J-122JE	1	435031224R1
PCB-U007	R8915	C-CARBON R	RN72K1J-122JE	1	435031224R1
PCB-U007	R8916	C-CARBON R	RN72K1J-122JE	1	435031224R1
PCB-U007	R8917	C-CARBON R	RN72K1J-122JE	1	435031224R1
PCB-U007	R8918	C-CARBON R	RN72K1J-122JE	1	435031224R1
PCB-U007	R8919	C-CARBON R	RN72K1J-122JE	1	435031224R1
PCB-U007	R8920	C-CARBON R	RN72K1J-122JE	1	435031224R1
PCB-U007	R8921	C-CARBON R	RN72K1J-122JE	1	435031224R1
PCB-U007	R8922	C-CARBON R	RN72K1J-122JE	1	435031224R1
PCB-U007	R8923	C-CARBON R	RN72K1J-122JE	1	435031224R1
PCB-U007	R8924	C-CARBON R	RN72K1J-122JE	1	435031224R1
PCB-U007	R8940	C-CARBON R	RN72K1J-104JE	1	435031044R1
PCB-U007	R8941	C-CARBON R	RN72K1J-104JE	1	435031044R1
PCB-U007	R8942	C-CARBON R	RN72K1J-103JE	1	435031034R1
PCB-U007	R8946	C-CARBON R	RN72K1J-000JE	1	435030004R1
PCB-U007	R8951	C-CARBON R	RN72K1J-103JE	1	435031034R1
PCB-U007	R8952	C-CARBON R	RN72K1J-683JE	1	435036834R1



PCB-U007	R8953	C-CARBON R	RN72K1J-183FE	1	435031832R1
PCB-U007	R8954	C-CARBON R	RN72K1J-224FE	1	435032242R1
PCB-U007	R8955	C-CARBON R	RN72K1J-103FE	1	435031032R1
PCB-U007	R8957	C-CARBON R	RN72K1J-333JE	1	435033334R1
PCB-U007	R8958	C-CARBON R	RN72K1J-000JE	1	435030004R1
PCB-U007	R8960	C-CARBON R	RN72K1J-103FE	1	435031032R1
PCB-U007	R8962	C-CARBON R	RN72K1J-333JE	1	435033334R1
PCB-U007	R8963	C-CARBON R	RN72K1J-153FE	1	435031532R1
PCB-U007	R8964	C-CARBON R	RN72K1J-333FE	1	435033332R1
PCB-U007	R8965	C-CARBON R	RN72K1J-103FE	1	435031032R1
PCB-U007	R8967	C-CARBON R	RN72K1J-683JE	1	435036834R1
PCB-U007	R8968	C-CARBON R	RN72K1J-333FE	1	435033332R1
PCB-U007	R8969	C-CARBON R	RN72K1J-394FE	1	435033942R1
PCB-U007	R8970	C-CARBON R	RN72K1J-103FE	1	435031032R1
PCB-U007	R8971	C-CARBON R	RN72K1J-473JE	1	435034734R1
PCB-U007	R8972	C-CARBON R	RN72K1J-103JE	1	435031034R1
PCB-U007	R8973	C-CARBON R	RN72K1J-103JE	1	435031034R1
PCB-U007	R8974	C-CARBON R	RN72K1J-103JE	1	435031034R1
PCB-U007	R8976	C-CARBON R	RN72K1J-103JE	1	435031034R1
PCB-U007	R8977	C-CARBON R	RN72K1J-562JE	1	435035624R1
PCB-U007	R8978	C-CARBON R	RN72K1J-682JE	1	435036824R1
PCB-U007	R8979	C-CARBON R	RN72K1J-562JE	1	435035624R1
PCB-U007	RN8013	C-R NET	RM7LJ330X04	1	43484733004R2
PCB-U007	RN8014	C-R NET	RM7LJ330X04	1	43484733004R2
PCB-U007	RN8015	C-R NET	RM7LJ330X04	1	43484733004R2
PCB-U007	RN8016	C-R NET	RM7LJ330X04	1	43484733004R2
PCB-U007	RN8017	C-R NET	RM7LJ330X04	1	43484733004R2
PCB-U007	RN8018	C-R NET	RM7LJ330X04	1	43484733004R2
PCB-U007	RN8019	C-R NET	RM7LJ330X04	1	43484733004R2
PCB-U007	RN8020	C-R NET	RM7LJ330X04	1	43484733004R2
PCB-U007	RN8021	C-R NET	RM7LJ330X04	1	43484733004R2
PCB-U007	RN8022	C-R NET	RM7LJ330X04	1	43484733004R2
PCB-U007	RN8023	C-R NET	RM7LJ330X04	1	43484733004R2

PCB-U007	RN8024	C-R NET	RM7LJ330X04	1	43484733004R2
PCB-U007	RN8025	C-R NET	RM7LJ330X04	1	43484733004R2
PCB-U007	RN8026	C-R NET	RM7LJ330X04	1	43484733004R2
PCB-U007	RN8027	C-R NET	RM7LJ330X04	1	43484733004R2
PCB-U007	RN8028	C-R NET	RM7LJ330X04	1	43484733004R2
PCB-U007	RN8029	C-R NET	RM7LJ330X04	1	43484733004R2
PCB-U007	RN8030	C-R NET	RM7LJ330X04	1	43484733004R2
PCB-U007	RN8037	C-R NET	RM7LJ330X04	1	43484733004R2
PCB-U007	RN8038	C-R NET	RM7LJ330X04	1	43484733004R2
PCB-U007	RN8039	C-R NET	RM7LJ330X04	1	43484733004R2
PCB-U007	RN8041	C-R NET	RM7LJ330X04	1	43484733004R2
PCB-U007	RN8043	C-R NET	RM7LJ330X04	1	43484733004R2
PCB-U007	RN8045	C-R NET	RM7LJ330X04	1	43484733004R2
PCB-U007	RN8048	C-R NET	RM7LJ330X04	1	43484733004R2
PCB-U007	RN8049	C-R NET	RM7LJ330X04	1	43484733004R2
PCB-U007	RN8050	C-R NET	RM7LJ330X04	1	43484733004R2
PCB-U007	RN8051	C-R NET	RM7LJ330X04	1	43484733004R2
PCB-U007	RN8052	C-R NET	RM7LJ330X04	1	43484733004R2
PCB-U007	RN8053	C-R NET	RM7LJ330X04	1	43484733004R2
PCB-U007	RN8054	C-R NET	RM7LJ330X04	1	43484733004R2
PCB-U007	RN8055	C-R NET	RM7LJ330X04	1	43484733004R2
PCB-U007	RN8056	C-R NET	RM7LJ330X04	1	43484733004R2
PCB-U007	RN8057	C-R NET	RM7LJ330X04	1	43484733004R2
PCB-U007	RN8058	C-R NET	RM7LJ330X04	1	43484733004R2
PCB-U007	RN8059	C-R NET	RM7LJ330X04	1	43484733004R2
PCB-U007	RN8060	C-R NET	RM7LJ330X04	1	43484733004R2
PCB-U007	RN8061	C-R NET	RM7LJ330X04	1	43484733004R2
PCB-U007	RN8062	C-R NET	RM7LJ680X04	1	43484768004R2
PCB-U007	RN8063	C-R NET	RM7LJ470X04	1	43484747004R2
PCB-U007	RN8064	C-R NET	RM7LJ680X04	1	43484768004R2
PCB-U007	RN8065	C-R NET	RM7LJ470X04	1	43484747004R2
PCB-U007	RN8066	C-R NET	RM7LJ680X04	1	43484768004R2
PCB-U007	RN8067	C-R NET	RM7LJ470X04	1	43484747004R2

PCB-U007	RN8068	C-R NET	RM7LJ680X04	1	43484768004R2	
PCB-U007	RN8069	C-R NET	RM7LJ470X04	1	43484747004R2	
PCB-U007	RN8070	C-R NET	RM7LJ680X04	1	43484768004R2	
PCB-U007	RN8071	C-R NET	RM7LJ680X04	1	43484768004R2	
PCB-U007	RN8072	C-R NET	RM7LJ470X04	1	43484747004R2	
PCB-U007	RN8073	C-R NET	RM7LJ680X04	1	43484768004R2	
PCB-U007	RN8074	C-R NET	RM7LJ470X04	1	43484747004R2	
PCB-U007	RN8075	C-R NET	RM7LJ680X04	1	43484768004R2	
PCB-U007	RN8076	C-R NET	RM7LJ680X04	1	43484768004R2	
PCB-U007	RN8077	C-R NET	RM7LJ680X04	1	43484768004R2	
PCB-U007	RN8078	C-R NET	RM7LJ680X04	1	43484768004R2	
PCB-U007	RN8079	C-R NET	RM7LJ680X04	1	43484768004R2	
PCB-U007	RN8080	C-R NET	RM7LJ680X04	1	43484768004R2	
PCB-U007	RN8081	C-R NET	RM7LJ680X04	1	43484768004R2	
PCB-U007	RN8082	C-R NET	RM7LJ680X04	1	43484768004R2	
PCB-U007	RN8083	C-R NET	RM7LJ680X04	1	43484768004R2	
PCB-U007	RN8087	C-R NET	RM7LJ103X04	1	43484710304R2	
PCB-U007	RN8088	C-R NET	RM7LJ103X04	1	43484710304R2	
PCB-U007	RN8703	C-R NET	RM7LJ680X04	1	43484768004R2	
PCB-U007	RN8704	C-R NET	RM7LJ680X04	1	43484768004R2	
PCB-U007	RN8705	C-R NET	RM7LJ680X04	1	43484768004R2	
PCB-U007	RN8706	C-R NET	RM7LJ680X04	1	43484768004R2	
PCB-U007	<a href="#">[SW TRM]</a>					
PCB-U007	JL3201	WIRE TRAP	NPLG-5P588	1	25055626	
PCB-U007	JL3889B	SOCKET	NSCT-5P97	1	25050269	
PCB-U007	JL8002B	SOCKET	NSCT-5P97	1	25050269	
PCB-U007	P3001	SOCKET(B to B)	IMSA-9850S-20Y900	1	25052813R2	
PCB-U007	P3101A	PLUG	NPLG-5P918	1	25055965R2	
PCB-U007	P3102A	SOCKET	NSCT-9P2472	1	25052575R2	
PCB-U007	P3104	SOCKET	SI-60073-F	1	25053307	
PCB-U007	P3104 or	SOCKET	J0026D21NL	( 1)	25053250	
PCB-U007	P3605A	PLUG	IMSA-9142B-18A	1	25056599	
PCB-U007	P3606A	PLUG	IMSA-9142B-8A	1	25056594	N

PCB-U007	P3607A	PLUG	IMSA-9142B-16A	1	25056598	
PCB-U007	P3608A	PLUG	IMSA-9142B-18A	1	25056599	
PCB-U007	P3609	SOCKET	IMSA-9618S-04A	1	25053329R2	
PCB-U007	P3609 or	SOCKET	04FMN-SMT-A-TF	( 1)	25052821R2	
PCB-U007	P4104A	SOCKET	NSCT-31P2124	1	25052227	
PCB-U007	P8100	TRM-423(SCREW)	NEJITANSI ST3	1	25060495	
PCB-U007	P8302	SOCKET	YKF45-7037V	1	25053253R3	
PCB-U007	P8321	SOCKET	YKF45-7037V	1	25053253R3	
PCB-U007	P8341	SOCKET	YKF45-7037V	1	25053253R3	
PCB-U007	P8352	SOCKET	YKF45-7037V	1	25053253R3	
PCB-U007	P8500	PWB	BCHDM-0157	1	25140157C	N
PCB-U007	P8601	SOCKET	YKF45-7037V	1	25053253R3	
PCB-U007	P8611	SOCKET	YKF45-7037V	1	25053253R3	
PCB-U007	P8621	SOCKET	YKF45-7037V	1	25053253R3	
PCB-U007	P8631	SOCKET	YKF45-7037V	1	25053253R3	
PCB-U007	P8641B	SOCKET	FX16-31S-0.5SH	1	25053365R2	N
PCB-U007	P8702	SOCKET	NSCT-9P2472	1	25052575R2	
PCB-U007	P8705	SOCKET	IMSA-9618S-04A	1	25053329R2	
PCB-U007	P8705 or	SOCKET	04FMN-SMT-A-TF	( 1)	25052821R2	
PCB-U008	<b>U0080</b>	AMPLIFIER PC BOARD (L/SL/SBL/LH) (BACLA-0226-1A)				
PCB-U008	<b>U0081</b>	AMPLIFIER PC BOARD (R/SR/SBR/RH/C) (BACLA-0227-1A)				
PCB-U008	<b>U0082</b>	AMPLIFIER PC BOARD (R/SR/SBR/RH/C) (BACLA-0228-1A)				
PCB-U008	<b>U0083</b>	AMPLIFIER PC BOARD (L/SL/SBL/LH) (BACLA-0229-1A)				
PCB-U008	<b>U0084</b>	AMPLIFIER PC BOARD (R/SR/SBR/RH/C) (BACLA-0230-1A)				
PCB-U008	<b>U0085</b>	AMPLIFIER PC BOARD (L/SL/SBL/LH) (BACLA-0231-1A)				
PCB-U008	<b>U0086</b>	AMPLIFIER PC BOARD (R/SR/SBR/RH/C) (BACLA-0232-1A)				
PCB-U008	<b>U0087</b>	AMPLIFIER PC BOARD (L/SL/SBL/LH) (BACLA-0233-1A)				
PCB-U008	<b>U0088</b>	AMPLIFIER PC BOARD (R/SR/SBR/RH/C) (BACLA-0234-1A)				
PCB-U008						
PCB-U008	<b>CIRCUIT. PART NAME</b>	<b>DESCRIPTION</b>	<b>Q'TY</b>	<b>PART NO. (SN)</b>	<b>REMARKS</b>	
PCB-U008	<b>[SEMI CONDUCTOR]</b>					
PCB-U008	D5000	ZENER D	1	224470562T		

PCB-U008	D5001	ZENER D	MTZJ5.6B	1	224470562T
PCB-U008	D5002	ZENER D	MTZJ5.6B	1	224470562T
PCB-U008	D5003	ZENER D	MTZJ5.6B	1	224470562T
PCB-U008	D5004	ZENER D	MTZJ5.6B	1	224470562T
PCB-U008	D5005	ZENER D	MTZJ5.6B	1	224470562T
PCB-U008	D5006	ZENER D	MTZJ5.6B	1	224470562T
PCB-U008	D5007	ZENER D	MTZJ5.6B	1	224470562T
PCB-U008	D5008	ZENER D	MTZJ5.6B	1	224470562T
PCB-U008	Q5000	TR	2SC2240-BL(TPE2_F)	1	2211406T
PCB-U008	Q5001	TR	2SC2240-BL(TPE2_F)	1	2211406T
PCB-U008	Q5002	TR	2SC2240-BL(TPE2_F)	1	2211406T
PCB-U008	Q5003	TR	2SC2240-BL(TPE2_F)	1	2211406T
PCB-U008	Q5004	TR	2SC2240-BL(TPE2_F)	1	2211406T
PCB-U008	Q5005	TR	2SC2240-BL(TPE2_F)	1	2211406T
PCB-U008	Q5006	TR	2SC2240-BL(TPE2_F)	1	2211406T
PCB-U008	Q5007	TR	2SC2240-BL(TPE2_F)	1	2211406T
PCB-U008	Q5008	TR	2SC2240-BL(TPE2_F)	1	2211406T
PCB-U008	Q5010	TR	2SC2240-BL(TPE2_F)	1	2211406T
PCB-U008	Q5011	TR	2SC2240-BL(TPE2_F)	1	2211406T
PCB-U008	Q5012	TR	2SC2240-BL(TPE2_F)	1	2211406T
PCB-U008	Q5013	TR	2SC2240-BL(TPE2_F)	1	2211406T
PCB-U008	Q5014	TR	2SC2240-BL(TPE2_F)	1	2211406T
PCB-U008	Q5015	TR	2SC2240-BL(TPE2_F)	1	2211406T
PCB-U008	Q5016	TR	2SC2240-BL(TPE2_F)	1	2211406T
PCB-U008	Q5017	TR	2SC2240-BL(TPE2_F)	1	2211406T
PCB-U008	Q5018	TR	2SC2240-BL(TPE2_F)	1	2211406T
PCB-U008	Q5020	TR	2SC2240-BL(TPE2_F)	1	2211406T
PCB-U008	Q5021	TR	2SC2240-BL(TPE2_F)	1	2211406T
PCB-U008	Q5022	TR	2SC2240-BL(TPE2_F)	1	2211406T
PCB-U008	Q5023	TR	2SC2240-BL(TPE2_F)	1	2211406T
PCB-U008	Q5024	TR	2SC2240-BL(TPE2_F)	1	2211406T
PCB-U008	Q5025	TR	2SC2240-BL(TPE2_F)	1	2211406T
PCB-U008	Q5026	TR	2SC2240-BL(TPE2_F)	1	2211406T

PCB-U008	Q5027	TR	2SC2240-BL(TPE2_F)	1	2211406T	
PCB-U008	Q5028	TR	2SC2240-BL(TPE2_F)	1	2211406T	
PCB-U008	Q5030	TR	2SA949-O(TPE6_F)	1	2211353T	
PCB-U008	Q5030 or	TR	2SA949-Y(TPE6_F)	(1)	2211354T	
PCB-U008	Q5031	TR	2SA949-O(TPE6_F)	1	2211353T	
PCB-U008	Q5031 or	TR	2SA949-Y(TPE6_F)	(1)	2211354T	
PCB-U008	Q5032	TR	2SA949-O(TPE6_F)	1	2211353T	
PCB-U008	Q5032 or	TR	2SA949-Y(TPE6_F)	(1)	2211354T	
PCB-U008	Q5033	TR	2SA949-O(TPE6_F)	1	2211353T	
PCB-U008	Q5033 or	TR	2SA949-Y(TPE6_F)	(1)	2211354T	
PCB-U008	Q5034	TR	2SA949-O(TPE6_F)	1	2211353T	
PCB-U008	Q5034 or	TR	2SA949-Y(TPE6_F)	(1)	2211354T	
PCB-U008	Q5035	TR	2SA949-O(TPE6_F)	1	2211353T	
PCB-U008	Q5035 or	TR	2SA949-Y(TPE6_F)	(1)	2211354T	
PCB-U008	Q5036	TR	2SA949-O(TPE6_F)	1	2211353T	
PCB-U008	Q5036 or	TR	2SA949-Y(TPE6_F)	(1)	2211354T	
PCB-U008	Q5037	TR	2SA949-O(TPE6_F)	1	2211353T	
PCB-U008	Q5037 or	TR	2SA949-Y(TPE6_F)	(1)	2211354T	
PCB-U008	Q5038	TR	2SA949-O(TPE6_F)	1	2211353T	
PCB-U008	Q5038 or	TR	2SA949-Y(TPE6_F)	(1)	2211354T	
PCB-U008	Q5040	TR	2SA949-O(TPE6_F)	1	2211353T	
PCB-U008	Q5040 or	TR	2SA949-Y(TPE6_F)	(1)	2211354T	
PCB-U008	Q5041	TR	2SA949-O(TPE6_F)	1	2211353T	
PCB-U008	Q5041 or	TR	2SA949-Y(TPE6_F)	(1)	2211354T	
PCB-U008	Q5042	TR	2SA949-O(TPE6_F)	1	2211353T	
PCB-U008	Q5042 or	TR	2SA949-Y(TPE6_F)	(1)	2211354T	
PCB-U008	Q5043	TR	2SA949-O(TPE6_F)	1	2211353T	
PCB-U008	Q5043 or	TR	2SA949-Y(TPE6_F)	(1)	2211354T	
PCB-U008	Q5044	TR	2SA949-O(TPE6_F)	1	2211353T	
PCB-U008	Q5044 or	TR	2SA949-Y(TPE6_F)	(1)	2211354T	
PCB-U008	Q5045	TR	2SA949-O(TPE6_F)	1	2211353T	
PCB-U008	Q5045 or	TR	2SA949-Y(TPE6_F)	(1)	2211354T	
PCB-U008	Q5046	TR	2SA949-O(TPE6_F)	1	2211353T	

PCB-U008	Q5046 or	TR	2SA949-Y(TPE6_F)	(1)	2211354T	
PCB-U008	Q5047	TR	2SA949-O(TPE6_F)	1	2211353T	
PCB-U008	Q5047 or	TR	2SA949-Y(TPE6_F)	(1)	2211354T	
PCB-U008	Q5048	TR	2SA949-O(TPE6_F)	1	2211353T	
PCB-U008	Q5048 or	TR	2SA949-Y(TPE6_F)	(1)	2211354T	
PCB-U008	Q5050	TR	2SA1360-Y	1	2202094	
PCB-U008	Q5050 or	TR	2SA1360-O	(1)	2202093	
PCB-U008	Q5051	TR	2SA1360-Y	1	2202094	
PCB-U008	Q5051 or	TR	2SA1360-O	(1)	2202093	
PCB-U008	Q5052	TR	2SA1360-Y	1	2202094	
PCB-U008	Q5052 or	TR	2SA1360-O	(1)	2202093	
PCB-U008	Q5053	TR	2SA1360-Y	1	2202094	
PCB-U008	Q5053 or	TR	2SA1360-O	(1)	2202093	
PCB-U008	Q5054	TR	2SA1360-Y	1	2202094	
PCB-U008	Q5054 or	TR	2SA1360-O	(1)	2202093	
PCB-U008	Q5055	TR	2SA1360-Y	1	2202094	
PCB-U008	Q5055 or	TR	2SA1360-O	(1)	2202093	
PCB-U008	Q5056	TR	2SA1360-Y	1	2202094	
PCB-U008	Q5056 or	TR	2SA1360-O	(1)	2202093	
PCB-U008	Q5057	TR	2SA1360-Y	1	2202094	
PCB-U008	Q5057 or	TR	2SA1360-O	(1)	2202093	
PCB-U008	Q5058	TR	2SA1360-Y	1	2202094	
PCB-U008	Q5058 or	TR	2SA1360-O	(1)	2202093	
PCB-U008	Q5060	TR	2SC2240-BL(TPE2_F)	1	2211406T	
PCB-U008	Q5061	TR	2SC2240-BL(TPE2_F)	1	2211406T	
PCB-U008	Q5062	TR	2SC2240-BL(TPE2_F)	1	2211406T	
PCB-U008	Q5063	TR	2SC2240-BL(TPE2_F)	1	2211406T	
PCB-U008	Q5064	TR	2SC2240-BL(TPE2_F)	1	2211406T	
PCB-U008	Q5065	TR	2SC2240-BL(TPE2_F)	1	2211406T	
PCB-U008	Q5066	TR	2SC2240-BL(TPE2_F)	1	2211406T	
PCB-U008	Q5067	TR	2SC2240-BL(TPE2_F)	1	2211406T	
PCB-U008	Q5068	TR	2SC2240-BL(TPE2_F)	1	2211406T	
PCB-U008	Q5070	TR	2SC2240-BL(TPE2_F)	1	2211406T	

PCB-U008	Q5071	TR	2SC2240-BL(TPE2_F)	1	2211406T	
PCB-U008	Q5072	TR	2SC2240-BL(TPE2_F)	1	2211406T	
PCB-U008	Q5073	TR	2SC2240-BL(TPE2_F)	1	2211406T	
PCB-U008	Q5074	TR	2SC2240-BL(TPE2_F)	1	2211406T	
PCB-U008	Q5075	TR	2SC2240-BL(TPE2_F)	1	2211406T	
PCB-U008	Q5076	TR	2SC2240-BL(TPE2_F)	1	2211406T	
PCB-U008	Q5077	TR	2SC2240-BL(TPE2_F)	1	2211406T	
PCB-U008	Q5078	TR	2SC2240-BL(TPE2_F)	1	2211406T	
PCB-U008	Q5080	TR	2SC3423-Y	1	2202104	
PCB-U008	Q5080 or	TR	2SC3423-O	( 1)	2202103	
PCB-U008	Q5080A	HEAT SINK	(CLA)B	1	27160642	N
PCB-U008	Q5080B	SCREW	3TTB+8B(3BC)	4	838430088GR	
PCB-U008	Q5081	TR	2SC3423-Y	1	2202104	
PCB-U008	Q5081 or	TR	2SC3423-O	( 1)	2202103	
PCB-U008	Q5081A	HEAT SINK	(CLA)B	1	27160642	N
PCB-U008	Q5081B	SCREW	3TTB+8B(3BC)	4	838430088GR	
PCB-U008	Q5082	TR	2SC3423-Y	1	2202104	
PCB-U008	Q5082 or	TR	2SC3423-O	( 1)	2202103	
PCB-U008	Q5082A	HEAT SINK	(CLA)B	1	27160642	N
PCB-U008	Q5082B	SCREW	3TTB+8B(3BC)	4	838430088GR	
PCB-U008	Q5083	TR	2SC3423-Y	1	2202104	
PCB-U008	Q5083 or	TR	2SC3423-O	( 1)	2202103	
PCB-U008	Q5083A	HEAT SINK	(CLA)B	1	27160642	N
PCB-U008	Q5083B	SCREW	3TTB+8B(3BC)	4	838430088GR	
PCB-U008	Q5084	TR	2SC3423-Y	1	2202104	
PCB-U008	Q5084 or	TR	2SC3423-O	( 1)	2202103	
PCB-U008	Q5084A	HEAT SINK	(CLA)B	1	27160642	N
PCB-U008	Q5084B	SCREW	3TTB+8B(3BC)	4	838430088GR	
PCB-U008	Q5085	TR	2SC3423-Y	1	2202104	
PCB-U008	Q5085 or	TR	2SC3423-O	( 1)	2202103	
PCB-U008	Q5085A	HEAT SINK	(CLA)B	1	27160642	N
PCB-U008	Q5085B	SCREW	3TTB+8B(3BC)	4	838430088GR	
PCB-U008	Q5086	TR	2SC3423-Y	1	2202104	



PCB-U008	Q5086 or TR	2SC3423-O	( 1)	2202103	
PCB-U008	Q5086A HEAT SINK	(CLA)B	1	27160642	N
PCB-U008	Q5086B SCREW	3TTB+8B(3BC)	4	838430088GR	
PCB-U008	Q5087 TR	2SC3423-Y	1	2202104	
PCB-U008	Q5087 or TR	2SC3423-O	( 1)	2202103	
PCB-U008	Q5087A HEAT SINK	(CLA)B	1	27160642	N
PCB-U008	Q5087B SCREW	3TTB+8B(3BC)	4	838430088GR	
PCB-U008	Q5088 TR	2SC3423-Y	1	2202104	
PCB-U008	Q5088 or TR	2SC3423-O	( 1)	2202103	
PCB-U008	Q5088B SCREW	3TTB+8B(3BC)	4	838430088GR	
PCB-U008	Q5888A HEAT SINK	(CLA)B	1	27160642	N
PCB-U008	Q6010 TR	2SC1740S-S	1	2213285T	
PCB-U008	Q6011 TR	2SC1740S-S	1	2213285T	
PCB-U008	Q6012 TR	2SC1740S-S	1	2213285T	
PCB-U008	Q6013 TR	2SC1740S-S	1	2213285T	
PCB-U008	Q6014 TR	2SC1740S-S	1	2213285T	
PCB-U008	Q6015 TR	2SC1740S-S	1	2213285T	
PCB-U008	Q6016 TR	2SC1740S-S	1	2213285T	
PCB-U008	Q6017 TR	2SC1740S-S	1	2213285T	
PCB-U008	Q6018 TR	2SC1740S-S	1	2213285T	
PCB-U008	Q6020 TR	2SA933S-R	1	2213354T	
PCB-U008	Q6020 or TR	2SA1048-GR	( 1)	2212125T	
PCB-U008	Q6020 or TR	2SA933S-S	( 1)	2213355T	
PCB-U008	Q6020 or TR	KTA1267-GR	( 1)	2215995T	
PCB-U008	Q6021 TR	2SA933S-R	1	2213354T	
PCB-U008	Q6021 or TR	2SA1048-GR	( 1)	2212125T	
PCB-U008	Q6021 or TR	2SA933S-S	( 1)	2213355T	
PCB-U008	Q6021 or TR	KTA1267-GR	( 1)	2215995T	
PCB-U008	Q6022 TR	2SA933S-R	1	2213354T	
PCB-U008	Q6022 or TR	2SA1048-GR	( 1)	2212125T	
PCB-U008	Q6022 or TR	2SA933S-S	( 1)	2213355T	
PCB-U008	Q6022 or TR	KTA1267-GR	( 1)	2215995T	
PCB-U008	Q6023 TR	2SA933S-R	1	2213354T	

PCB-U008	Q6023 or TR	2SA1048-GR	(1)	2212125T	
PCB-U008	Q6023 or TR	2SA933S-S	(1)	2213355T	
PCB-U008	Q6023 or TR	KTA1267-GR	(1)	2215995T	
PCB-U008	Q6024 TR	2SA933S-R	1	2213354T	
PCB-U008	Q6024 or TR	2SA1048-GR	(1)	2212125T	
PCB-U008	Q6024 or TR	2SA933S-S	(1)	2213355T	
PCB-U008	Q6024 or TR	KTA1267-GR	(1)	2215995T	
PCB-U008	Q6025 TR	2SA933S-R	1	2213354T	
PCB-U008	Q6025 or TR	2SA1048-GR	(1)	2212125T	
PCB-U008	Q6025 or TR	2SA933S-S	(1)	2213355T	
PCB-U008	Q6025 or TR	KTA1267-GR	(1)	2215995T	
PCB-U008	Q6026 TR	2SA933S-R	1	2213354T	
PCB-U008	Q6026 or TR	2SA1048-GR	(1)	2212125T	
PCB-U008	Q6026 or TR	2SA933S-S	(1)	2213355T	
PCB-U008	Q6026 or TR	KTA1267-GR	(1)	2215995T	
PCB-U008	Q6027 TR	2SA933S-R	1	2213354T	
PCB-U008	Q6027 or TR	2SA1048-GR	(1)	2212125T	
PCB-U008	Q6027 or TR	2SA933S-S	(1)	2213355T	
PCB-U008	Q6027 or TR	KTA1267-GR	(1)	2215995T	
PCB-U008	Q6028 TR	2SA933S-R	1	2213354T	
PCB-U008	Q6028 or TR	2SA1048-GR	(1)	2212125T	
PCB-U008	Q6028 or TR	2SA933S-S	(1)	2213355T	
PCB-U008	Q6028 or TR	KTA1267-GR	(1)	2215995T	
PCB-U008	Q6030 TR	2SC2229-O(TPE6_F)	1	2211633T	
PCB-U008	Q6030 or TR	2SC2229-Y(TPE6_F)	(1)	2211634T	
PCB-U008	Q6031 TR	2SC2229-O(TPE6_F)	1	2211633T	
PCB-U008	Q6031 or TR	2SC2229-Y(TPE6_F)	(1)	2211634T	
PCB-U008	Q6032 TR	2SC2229-O(TPE6_F)	1	2211633T	
PCB-U008	Q6032 or TR	2SC2229-Y(TPE6_F)	(1)	2211634T	
PCB-U008	Q6033 TR	2SC2229-O(TPE6_F)	1	2211633T	
PCB-U008	Q6033 or TR	2SC2229-Y(TPE6_F)	(1)	2211634T	
PCB-U008	Q6034 TR	2SC2229-O(TPE6_F)	1	2211633T	
PCB-U008	Q6034 or TR	2SC2229-Y(TPE6_F)	(1)	2211634T	

PCB-U008	Q6035	TR	2SC2229-O(TPE6_F)	1	2211633T		
PCB-U008	Q6035 or	TR	2SC2229-Y(TPE6_F)	(1)	2211634T		
PCB-U008	Q6036	TR	2SC2229-O(TPE6_F)	1	2211633T		
PCB-U008	Q6036 or	TR	2SC2229-Y(TPE6_F)	(1)	2211634T		
PCB-U008	Q6037	TR	2SC2229-O(TPE6_F)	1	2211633T		
PCB-U008	Q6037 or	TR	2SC2229-Y(TPE6_F)	(1)	2211634T		
PCB-U008	Q6038	TR	2SC2229-O(TPE6_F)	1	2211633T		
PCB-U008	Q6038 or	TR	2SC2229-Y(TPE6_F)	(1)	2211634T		
PCB-U008	Q6040	TR	2SA949-O(TPE6_F)	1	2211353T		
PCB-U008	Q6040 or	TR	2SA949-Y(TPE6_F)	(1)	2211354T		
PCB-U008	Q6041	TR	2SA949-O(TPE6_F)	1	2211353T		
PCB-U008	Q6041 or	TR	2SA949-Y(TPE6_F)	(1)	2211354T		
PCB-U008	Q6042	TR	2SA949-O(TPE6_F)	1	2211353T		
PCB-U008	Q6042 or	TR	2SA949-Y(TPE6_F)	(1)	2211354T		
PCB-U008	Q6043	TR	2SA949-O(TPE6_F)	1	2211353T		
PCB-U008	Q6043 or	TR	2SA949-Y(TPE6_F)	(1)	2211354T		
PCB-U008	Q6044	TR	2SA949-O(TPE6_F)	1	2211353T		
PCB-U008	Q6044 or	TR	2SA949-Y(TPE6_F)	(1)	2211354T		
PCB-U008	Q6045	TR	2SA949-O(TPE6_F)	1	2211353T		
PCB-U008	Q6045 or	TR	2SA949-Y(TPE6_F)	(1)	2211354T		
PCB-U008	Q6046	TR	2SA949-O(TPE6_F)	1	2211353T		
PCB-U008	Q6046 or	TR	2SA949-Y(TPE6_F)	(1)	2211354T		
PCB-U008	Q6047	TR	2SA949-O(TPE6_F)	1	2211353T		
PCB-U008	Q6047 or	TR	2SA949-Y(TPE6_F)	(1)	2211354T		
PCB-U008	Q6048	TR	2SA949-O(TPE6_F)	1	2211353T		
PCB-U008	Q6048 or	TR	2SA949-Y(TPE6_F)	(1)	2211354T		
PCB-U008	Q6100	TR	TTA-004(Q)TO126	1	2217442		N
PCB-U008	Q6101	TR	TTA-004(Q)TO126	1	2217442		N
PCB-U008	Q6102	TR	TTA-004(Q)TO126	1	2217442		N
PCB-U008	Q6103	TR	TTA-004(Q)TO126	1	2217442		N
PCB-U008	Q6104	TR	TTA-004(Q)TO126	1	2217442		N
PCB-U008	Q6105	TR	TTA-004(Q)TO126	1	2217442		N
PCB-U008	Q6106	TR	TTA-004(Q)TO126	1	2217442		N

PCB-U008	Q6107	TR		TTA-004(Q)TO126	1	2217442	N
PCB-U008	Q6108	TR		TTA-004(Q)TO126	1	2217442	N
PCB-U008	Q6110	TR		TTC-004(Q)TO126	1	2217452	N
PCB-U008	Q6111	TR		TTC-004(Q)TO126	1	2217452	N
PCB-U008	Q6112	TR		TTC-004(Q)TO126	1	2217452	N
PCB-U008	Q6113	TR		TTC-004(Q)TO126	1	2217452	N
PCB-U008	Q6114	TR		TTC-004(Q)TO126	1	2217452	N
PCB-U008	Q6115	TR		TTC-004(Q)TO126	1	2217452	N
PCB-U008	Q6116	TR		TTC-004(Q)TO126	1	2217452	N
PCB-U008	Q6117	TR		TTC-004(Q)TO126	1	2217452	N
PCB-U008	Q6118	TR		TTC-004(Q)TO126	1	2217452	N
PCB-U008	<b>[CAPACITOR]</b>						
PCB-U008	C5000	UTSP C		CE04W50V-10M(UTSP)	1	397581007T	
PCB-U008	C5001	UTSP C		CE04W50V-10M(UTSP)	1	397581007T	
PCB-U008	C5002	UTSP C		CE04W50V-10M(UTSP)	1	397581007T	
PCB-U008	C5003	UTSP C		CE04W50V-10M(UTSP)	1	397581007T	
PCB-U008	C5004	UTSP C		CE04W50V-10M(UTSP)	1	397581007T	
PCB-U008	C5005	UTSP C		CE04W50V-10M(UTSP)	1	397581007T	
PCB-U008	C5006	UTSP C		CE04W50V-10M(UTSP)	1	397581007T	
PCB-U008	C5007	UTSP C		CE04W50V-10M(UTSP)	1	397581007T	
PCB-U008	C5008	UTSP C		CE04W50V-10M(UTSP)	1	397581007T	
PCB-U008	C5010	UTSJ C		CE04W50V-47M(UTSJ)	1	398084707T	
PCB-U008	C5011	UTSJ C		CE04W50V-47M(UTSJ)	1	398084707T	
PCB-U008	C5012	UTSJ C		CE04W50V-47M(UTSJ)	1	398084707T	
PCB-U008	C5013	UTSJ C		CE04W50V-47M(UTSJ)	1	398084707T	
PCB-U008	C5014	UTSJ C		CE04W50V-47M(UTSJ)	1	398084707T	
PCB-U008	C5015	UTSJ C		CE04W50V-47M(UTSJ)	1	398084707T	
PCB-U008	C5016	UTSJ C		CE04W50V-47M(UTSJ)	1	398084707T	
PCB-U008	C5017	UTSJ C		CE04W50V-47M(UTSJ)	1	398084707T	
PCB-U008	C5018	UTSJ C		CE04W50V-47M(UTSJ)	1	398084707T	
PCB-U008	C5020	UPZ C		2AUPZTF471JE	1	376334714T	
PCB-U008	C5021	UPZ C		2AUPZTF471JE	1	376334714T	
PCB-U008	C5022	UPZ C		2AUPZTF471JE	1	376334714T	

PCB-U008	C5023	UPZ C	2AUPZTF471JE	1	376334714T
PCB-U008	C5024	UPZ C	2AUPZTF471JE	1	376334714T
PCB-U008	C5025	UPZ C	2AUPZTF471JE	1	376334714T
PCB-U008	C5026	UPZ C	2AUPZTF471JE	1	376334714T
PCB-U008	C5027	UPZ C	2AUPZTF471JE	1	376334714T
PCB-U008	C5028	UPZ C	2AUPZTF471JE	1	376334714T
PCB-U008	C5040	UTSP C	CE04W25V-220M(UTSP)	1	397552217T
PCB-U008	C5041	UTSP C	CE04W25V-220M(UTSP)	1	397552217T
PCB-U008	C5042	UTSP C	CE04W25V-220M(UTSP)	1	397552217T
PCB-U008	C5043	UTSP C	CE04W25V-220M(UTSP)	1	397552217T
PCB-U008	C5044	UTSP C	CE04W25V-220M(UTSP)	1	397552217T
PCB-U008	C5045	UTSP C	CE04W25V-220M(UTSP)	1	397552217T
PCB-U008	C5046	UTSP C	CE04W25V-220M(UTSP)	1	397552217T
PCB-U008	C5047	UTSP C	CE04W25V-220M(UTSP)	1	397552217T
PCB-U008	C5048	UTSP C	CE04W25V-220M(UTSP)	1	397552217T
PCB-U008	C5070	VX C	CE04W100V-10M(VX_BLK)	1	397391007T
PCB-U008	C5071	VX C	CE04W100V-10M(VX_BLK)	1	397391007T
PCB-U008	C5072	VX C	CE04W100V-10M(VX_BLK)	1	397391007T
PCB-U008	C5073	VX C	CE04W100V-10M(VX_BLK)	1	397391007T
PCB-U008	C5074	VX C	CE04W100V-10M(VX_BLK)	1	397391007T
PCB-U008	C5075	VX C	CE04W100V-10M(VX_BLK)	1	397391007T
PCB-U008	C5076	VX C	CE04W100V-10M(VX_BLK)	1	397391007T
PCB-U008	C5077	VX C	CE04W100V-10M(VX_BLK)	1	397391007T
PCB-U008	C5078	VX C	CE04W100V-10M(VX_BLK)	1	397391007T
PCB-U008	C5080	VX C	CE04W63V-22M(VX_BLK)	1	397372207T
PCB-U008	C5081	VX C	CE04W63V-22M(VX_BLK)	1	397372207T
PCB-U008	C5082	VX C	CE04W63V-22M(VX_BLK)	1	397372207T
PCB-U008	C5083	VX C	CE04W63V-22M(VX_BLK)	1	397372207T
PCB-U008	C5084	VX C	CE04W63V-22M(VX_BLK)	1	397372207T
PCB-U008	C5085	VX C	CE04W63V-22M(VX_BLK)	1	397372207T
PCB-U008	C5086	VX C	CE04W63V-22M(VX_BLK)	1	397372207T
PCB-U008	C5087	VX C	CE04W63V-22M(VX_BLK)	1	397372207T
PCB-U008	C5088	VX C	CE04W63V-22M(VX_BLK)	1	397372207T

PCB-U008	C5100	UPZ C	2AUPZTF101JE	1	376331014T	
PCB-U008	C5101	UPZ C	2AUPZTF101JE	1	376331014T	
PCB-U008	C5102	UPZ C	2AUPZTF101JE	1	376331014T	
PCB-U008	C5103	UPZ C	2AUPZTF101JE	1	376331014T	
PCB-U008	C5104	UPZ C	2AUPZTF101JE	1	376331014T	
PCB-U008	C5105	UPZ C	2AUPZTF101JE	1	376331014T	
PCB-U008	C5106	UPZ C	2AUPZTF101JE	1	376331014T	
PCB-U008	C5107	UPZ C	2AUPZTF101JE	1	376331014T	
PCB-U008	C5108	UPZ C	2AUPZTF101JE	1	376331014T	
PCB-U008	C5110	CERA C	CC45CH50V-010C	1	345340101T	
PCB-U008	C5111	CERA C	CC45CH50V-010C	1	345340101T	
PCB-U008	C5112	CERA C	CC45CH50V-010C	1	345340101T	
PCB-U008	C5113	CERA C	CC45CH50V-010C	1	345340101T	
PCB-U008	C5114	CERA C	CC45CH50V-010C	1	345340101T	
PCB-U008	C5115	CERA C	CC45CH50V-010C	1	345340101T	
PCB-U008	C5116	CERA C	CC45CH50V-010C	1	345340101T	
PCB-U008	C5117	CERA C	CC45CH50V-010C	1	345340101T	
PCB-U008	C5118	CERA C	CC45CH50V-010C	1	345340101T	
PCB-U008	C5120	SPC C	CE04W100V-100M(RJ5)	1	396791017T	N
PCB-U008	C5121	SPC C	CE04W100V-100M(RJ5)	1	396791017T	N
PCB-U008	C5122	SPC C	CE04W100V-100M(RJ5)	1	396791017T	N
PCB-U008	C5123	SPC C	CE04W100V-100M(RJ5)	1	396791017T	N
PCB-U008	C5124	SPC C	CE04W100V-100M(RJ5)	1	396791017T	N
PCB-U008	C5125	SPC C	CE04W100V-100M(RJ5)	1	396791017T	N
PCB-U008	C5126	SPC C	CE04W100V-100M(RJ5)	1	396791017T	N
PCB-U008	C5127	SPC C	CE04W100V-100M(RJ5)	1	396791017T	N
PCB-U008	C5128	SPC C	CE04W100V-100M(RJ5)	1	396791017T	N
PCB-U008	C5130	SPC C	CE04W100V-100M(RJ5)	1	396791017T	N
PCB-U008	C5131	SPC C	CE04W100V-100M(RJ5)	1	396791017T	N
PCB-U008	C5132	SPC C	CE04W100V-100M(RJ5)	1	396791017T	N
PCB-U008	C5133	SPC C	CE04W100V-100M(RJ5)	1	396791017T	N
PCB-U008	C5134	SPC C	CE04W100V-100M(RJ5)	1	396791017T	N
PCB-U008	C5135	SPC C	CE04W100V-100M(RJ5)	1	396791017T	N

PCB-U008	C5136	SPC C	CE04W100V-100M(RJ5)	1	396791017T	N
PCB-U008	C5137	SPC C	CE04W100V-100M(RJ5)	1	396791017T	N
PCB-U008	C5138	SPC C	CE04W100V-100M(RJ5)	1	396791017T	N
PCB-U008	C6000	MKT C	B32529C0102J289	1	376491024T	
PCB-U008	C6001	MKT C	B32529C0102J289	1	376491024T	
PCB-U008	C6002	MKT C	B32529C0102J289	1	376491024T	
PCB-U008	C6003	MKT C	B32529C0102J289	1	376491024T	
PCB-U008	C6004	MKT C	B32529C0102J289	1	376491024T	
PCB-U008	C6005	MKT C	B32529C0102J289	1	376491024T	
PCB-U008	C6006	MKT C	B32529C0102J289	1	376491024T	
PCB-U008	C6007	MKT C	B32529C0102J289	1	376491024T	
PCB-U008	C6008	MKT C	B32529C0102J289	1	376491024T	
PCB-U008	C6010	UTSP C	CE04W50V 47M(UTSP)	1	397584707T	
PCB-U008	C6011	UTSP C	CE04W50V 47M(UTSP)	1	397584707T	
PCB-U008	C6012	UTSP C	CE04W50V 47M(UTSP)	1	397584707T	
PCB-U008	C6013	UTSP C	CE04W50V 47M(UTSP)	1	397584707T	
PCB-U008	C6014	UTSP C	CE04W50V 47M(UTSP)	1	397584707T	
PCB-U008	C6015	UTSP C	CE04W50V 47M(UTSP)	1	397584707T	
PCB-U008	C6016	UTSP C	CE04W50V 47M(UTSP)	1	397584707T	
PCB-U008	C6017	UTSP C	CE04W50V 47M(UTSP)	1	397584707T	
PCB-U008	C6018	UTSP C	CE04W50V 47M(UTSP)	1	397584707T	
PCB-U008	C6020	UTSP C	CE04W50V 47M(UTSP)	1	397584707T	
PCB-U008	C6021	UTSP C	CE04W50V 47M(UTSP)	1	397584707T	
PCB-U008	C6022	UTSP C	CE04W50V 47M(UTSP)	1	397584707T	
PCB-U008	C6023	UTSP C	CE04W50V 47M(UTSP)	1	397584707T	
PCB-U008	C6024	UTSP C	CE04W50V 47M(UTSP)	1	397584707T	
PCB-U008	C6025	UTSP C	CE04W50V 47M(UTSP)	1	397584707T	
PCB-U008	C6026	UTSP C	CE04W50V 47M(UTSP)	1	397584707T	
PCB-U008	C6027	UTSP C	CE04W50V 47M(UTSP)	1	397584707T	
PCB-U008	C6028	UTSP C	CE04W50V 47M(UTSP)	1	397584707T	
PCB-U008	<b>[RESISTOR]</b>					
PCB-U008	R5000	CARBON R	R16J-1K	1	417341024T	
PCB-U008	R5001	CARBON R	R16J-1K	1	417341024T	

PCB-U008	R5002	CARBON R	R16J-1K	1	417341024T
PCB-U008	R5003	CARBON R	R16J-1K	1	417341024T
PCB-U008	R5004	CARBON R	R16J-1K	1	417341024T
PCB-U008	R5005	CARBON R	R16J-1K	1	417341024T
PCB-U008	R5006	CARBON R	R16J-1K	1	417341024T
PCB-U008	R5007	CARBON R	R16J-1K	1	417341024T
PCB-U008	R5008	CARBON R	R16J-1K	1	417341024T
PCB-U008	R5010	CARBON R	R16J-56K	1	417345634T
PCB-U008	R5011	CARBON R	R16J-56K	1	417345634T
PCB-U008	R5012	CARBON R	R16J-56K	1	417345634T
PCB-U008	R5013	CARBON R	R16J-56K	1	417345634T
PCB-U008	R5014	CARBON R	R16J-56K	1	417345634T
PCB-U008	R5015	CARBON R	R16J-56K	1	417345634T
PCB-U008	R5016	CARBON R	R16J-56K	1	417345634T
PCB-U008	R5017	CARBON R	R16J-56K	1	417345634T
PCB-U008	R5018	CARBON R	R16J-56K	1	417345634T
PCB-U008	R5020	CARBON R	R16J-330	1	417343314T
PCB-U008	R5021	CARBON R	R16J-330	1	417343314T
PCB-U008	R5022	CARBON R	R16J-330	1	417343314T
PCB-U008	R5023	CARBON R	R16J-330	1	417343314T
PCB-U008	R5024	CARBON R	R16J-330	1	417343314T
PCB-U008	R5025	CARBON R	R16J-330	1	417343314T
PCB-U008	R5026	CARBON R	R16J-330	1	417343314T
PCB-U008	R5027	CARBON R	R16J-330	1	417343314T
PCB-U008	R5028	CARBON R	R16J-330	1	417343314T
PCB-U008	R5030	CARBON R	R16J-330	1	417343314T
PCB-U008	R5031	CARBON R	R16J-330	1	417343314T
PCB-U008	R5032	CARBON R	R16J-330	1	417343314T
PCB-U008	R5033	CARBON R	R16J-330	1	417343314T
PCB-U008	R5034	CARBON R	R16J-330	1	417343314T
PCB-U008	R5035	CARBON R	R16J-330	1	417343314T
PCB-U008	R5036	CARBON R	R16J-330	1	417343314T
PCB-U008	R5037	CARBON R	R16J-330	1	417343314T



PCB-U008	R5038	CARBON R	R16J-330	1	417343314T
PCB-U008	R5040	CARBON R	R16J-330	1	417343314T
PCB-U008	R5041	CARBON R	R16J-330	1	417343314T
PCB-U008	R5042	CARBON R	R16J-330	1	417343314T
PCB-U008	R5043	CARBON R	R16J-330	1	417343314T
PCB-U008	R5044	CARBON R	R16J-330	1	417343314T
PCB-U008	R5045	CARBON R	R16J-330	1	417343314T
PCB-U008	R5046	CARBON R	R16J-330	1	417343314T
PCB-U008	R5047	CARBON R	R16J-330	1	417343314T
PCB-U008	R5048	CARBON R	R16J-330	1	417343314T
PCB-U008	R5050	CARBON R	R16J-5.6K	1	417345624T
PCB-U008	R5051	CARBON R	R16J-5.6K	1	417345624T
PCB-U008	R5052	CARBON R	R16J-5.6K	1	417345624T
PCB-U008	R5053	CARBON R	R16J-5.6K	1	417345624T
PCB-U008	R5054	CARBON R	R16J-5.6K	1	417345624T
PCB-U008	R5055	CARBON R	R16J-5.6K	1	417345624T
PCB-U008	R5056	CARBON R	R16J-5.6K	1	417345624T
PCB-U008	R5057	CARBON R	R16J-5.6K	1	417345624T
PCB-U008	R5058	CARBON R	R16J-5.6K	1	417345624T
PCB-U008	R5060	CARBON R	R16J-2.7K	1	417342724T
PCB-U008	R5061	CARBON R	R16J-2.7K	1	417342724T
PCB-U008	R5062	CARBON R	R16J-2.7K	1	417342724T
PCB-U008	R5063	CARBON R	R16J-2.7K	1	417342724T
PCB-U008	R5064	CARBON R	R16J-2.7K	1	417342724T
PCB-U008	R5065	CARBON R	R16J-2.7K	1	417342724T
PCB-U008	R5066	CARBON R	R16J-2.7K	1	417342724T
PCB-U008	R5067	CARBON R	R16J-2.7K	1	417342724T
PCB-U008	R5068	CARBON R	R16J-2.7K	1	417342724T
PCB-U008	R5070	CARBON R	R16J-100K	1	417341044T
PCB-U008	R5071	CARBON R	R16J-100K	1	417341044T
PCB-U008	R5072	CARBON R	R16J-100K	1	417341044T
PCB-U008	R5073	CARBON R	R16J-100K	1	417341044T
PCB-U008	R5074	CARBON R	R16J-100K	1	417341044T

PCB-U008	R5075	CARBON R	R16J-100K	1	417341044T
PCB-U008	R5076	CARBON R	R16J-100K	1	417341044T
PCB-U008	R5077	CARBON R	R16J-100K	1	417341044T
PCB-U008	R5078	CARBON R	R16J-100K	1	417341044T
PCB-U008	R5090	CARBON R	R16J-1.8K	1	417341824T
PCB-U008	R5091	CARBON R	R16J-1.8K	1	417341824T
PCB-U008	R5092	CARBON R	R16J-1.8K	1	417341824T
PCB-U008	R5093	CARBON R	R16J-1.8K	1	417341824T
PCB-U008	R5094	CARBON R	R16J-1.8K	1	417341824T
PCB-U008	R5095	CARBON R	R16J-1.8K	1	417341824T
PCB-U008	R5096	CARBON R	R16J-1.8K	1	417341824T
PCB-U008	R5097	CARBON R	R16J-1.8K	1	417341824T
PCB-U008	R5098	CARBON R	R16J-1.8K	1	417341824T
PCB-U008	R5110	CARBON R	R16J-2.2K	1	417342224T
PCB-U008	R5111	CARBON R	R16J-2.2K	1	417342224T
PCB-U008	R5112	CARBON R	R16J-2.2K	1	417342224T
PCB-U008	R5113	CARBON R	R16J-2.2K	1	417342224T
PCB-U008	R5114	CARBON R	R16J-2.2K	1	417342224T
PCB-U008	R5115	CARBON R	R16J-2.2K	1	417342224T
PCB-U008	R5116	CARBON R	R16J-2.2K	1	417342224T
PCB-U008	R5117	CARBON R	R16J-2.2K	1	417342224T
PCB-U008	R5118	CARBON R	R16J-2.2K	1	417342224T
PCB-U008	R5120	CARBON R	R16J-2.2K	1	417342224T
PCB-U008	R5121	CARBON R	R16J-2.2K	1	417342224T
PCB-U008	R5122	CARBON R	R16J-2.2K	1	417342224T
PCB-U008	R5123	CARBON R	R16J-2.2K	1	417342224T
PCB-U008	R5124	CARBON R	R16J-2.2K	1	417342224T
PCB-U008	R5125	CARBON R	R16J-2.2K	1	417342224T
PCB-U008	R5126	CARBON R	R16J-2.2K	1	417342224T
PCB-U008	R5127	CARBON R	R16J-2.2K	1	417342224T
PCB-U008	R5128	CARBON R	R16J-2.2K	1	417342224T
PCB-U008	R5130	NF CARBON R	R25J-820	1	415478214T
PCB-U008	R5131	NF CARBON R	R25J-820	1	415478214T

PCB-U008	R5132	NF CARBON R	R25J-820	1	415478214T
PCB-U008	R5133	NF CARBON R	R25J-820	1	415478214T
PCB-U008	R5134	NF CARBON R	R25J-820	1	415478214T
PCB-U008	R5135	NF CARBON R	R25J-820	1	415478214T
PCB-U008	R5136	NF CARBON R	R25J-820	1	415478214T
PCB-U008	R5137	NF CARBON R	R25J-820	1	415478214T
PCB-U008	R5138	NF CARBON R	R25J-820	1	415478214T
PCB-U008	R5140	NF CARBON R	R25J-820	1	415478214T
PCB-U008	R5141	NF CARBON R	R25J-820	1	415478214T
PCB-U008	R5142	NF CARBON R	R25J-820	1	415478214T
PCB-U008	R5143	NF CARBON R	R25J-820	1	415478214T
PCB-U008	R5144	NF CARBON R	R25J-820	1	415478214T
PCB-U008	R5145	NF CARBON R	R25J-820	1	415478214T
PCB-U008	R5146	NF CARBON R	R25J-820	1	415478214T
PCB-U008	R5147	NF CARBON R	R25J-820	1	415478214T
PCB-U008	R5148	NF CARBON R	R25J-820	1	415478214T
PCB-U008	R5150	METAL O R	RS1/2WBJ-10K	1	443521034T
PCB-U008	R5151	METAL O R	RS1/2WBJ-10K	1	443521034T
PCB-U008	R5152	METAL O R	RS1/2WBJ-10K	1	443521034T
PCB-U008	R5153	METAL O R	RS1/2WBJ-10K	1	443521034T
PCB-U008	R5154	METAL O R	RS1/2WBJ-10K	1	443521034T
PCB-U008	R5155	METAL O R	RS1/2WBJ-10K	1	443521034T
PCB-U008	R5156	METAL O R	RS1/2WBJ-10K	1	443521034T
PCB-U008	R5157	METAL O R	RS1/2WBJ-10K	1	443521034T
PCB-U008	R5158	METAL O R	RS1/2WBJ-10K	1	443521034T
PCB-U008	R5160	NF CARBON R	R25J-1.0K	1	415471024T
PCB-U008	R5161	NF CARBON R	R25J-1.0K	1	415471024T
PCB-U008	R5162	NF CARBON R	R25J-1.0K	1	415471024T
PCB-U008	R5163	NF CARBON R	R25J-1.0K	1	415471024T
PCB-U008	R5164	NF CARBON R	R25J-1.0K	1	415471024T
PCB-U008	R5165	NF CARBON R	R25J-1.0K	1	415471024T
PCB-U008	R5166	NF CARBON R	R25J-1.0K	1	415471024T
PCB-U008	R5167	NF CARBON R	R25J-1.0K	1	415471024T

PCB-U008	R5168	NF CARBON R	R25J-1.0K	1	415471024T
PCB-U008	R5170	NF CARBON R	R25J-820	1	415478214T
PCB-U008	R5171	NF CARBON R	R25J-820	1	415478214T
PCB-U008	R5172	NF CARBON R	R25J-820	1	415478214T
PCB-U008	R5173	NF CARBON R	R25J-820	1	415478214T
PCB-U008	R5174	NF CARBON R	R25J-820	1	415478214T
PCB-U008	R5175	NF CARBON R	R25J-820	1	415478214T
PCB-U008	R5176	NF CARBON R	R25J-820	1	415478214T
PCB-U008	R5177	NF CARBON R	R25J-820	1	415478214T
PCB-U008	R5178	NF CARBON R	R25J-820	1	415478214T
PCB-U008	R5180	NF CARBON R	R25J-33	1	415473304T
PCB-U008	R5181	NF CARBON R	R25J-33	1	415473304T
PCB-U008	R5182	NF CARBON R	R25J-33	1	415473304T
PCB-U008	R5183	NF CARBON R	R25J-33	1	415473304T
PCB-U008	R5184	NF CARBON R	R25J-33	1	415473304T
PCB-U008	R5185	NF CARBON R	R25J-33	1	415473304T
PCB-U008	R5186	NF CARBON R	R25J-33	1	415473304T
PCB-U008	R5187	NF CARBON R	R25J-33	1	415473304T
PCB-U008	R5188	NF CARBON R	R25J-33	1	415473304T
PCB-U008	R5210	CARBON R	R16J-18K	1	417341834T
PCB-U008	R5211	CARBON R	R16J-18K	1	417341834T
PCB-U008	R5212	CARBON R	R16J-18K	1	417341834T
PCB-U008	R5213	CARBON R	R16J-18K	1	417341834T
PCB-U008	R5214	CARBON R	R16J-18K	1	417341834T
PCB-U008	R5215	CARBON R	R16J-18K	1	417341834T
PCB-U008	R5216	CARBON R	R16J-18K	1	417341834T
PCB-U008	R5217	CARBON R	R16J-18K	1	417341834T
PCB-U008	R5218	CARBON R	R16J-18K	1	417341834T
PCB-U008	R5220	CARBON R	R16J-18K	1	417341834T
PCB-U008	R5221	CARBON R	R16J-18K	1	417341834T
PCB-U008	R5222	CARBON R	R16J-18K	1	417341834T
PCB-U008	R5223	CARBON R	R16J-18K	1	417341834T
PCB-U008	R5224	CARBON R	R16J-18K	1	417341834T

PCB-U008	R5225	CARBON R	R16J-18K	1	417341834T
PCB-U008	R5226	CARBON R	R16J-18K	1	417341834T
PCB-U008	R5227	CARBON R	R16J-18K	1	417341834T
PCB-U008	R5228	CARBON R	R16J-18K	1	417341834T
PCB-U008	R5230	NF CARBON R	R25J-15	1	415471504T
PCB-U008	R5231	NF CARBON R	R25J-15	1	415471504T
PCB-U008	R5232	NF CARBON R	R25J-15	1	415471504T
PCB-U008	R5233	NF CARBON R	R25J-15	1	415471504T
PCB-U008	R5234	NF CARBON R	R25J-15	1	415471504T
PCB-U008	R5235	NF CARBON R	R25J-15	1	415471504T
PCB-U008	R5236	NF CARBON R	R25J-15	1	415471504T
PCB-U008	R5237	NF CARBON R	R25J-15	1	415471504T
PCB-U008	R5238	NF CARBON R	R25J-15	1	415471504T
PCB-U008	R5240	NF CARBON R	R25J-15	1	415471504T
PCB-U008	R5241	NF CARBON R	R25J-15	1	415471504T
PCB-U008	R5242	NF CARBON R	R25J-15	1	415471504T
PCB-U008	R5243	NF CARBON R	R25J-15	1	415471504T
PCB-U008	R5244	NF CARBON R	R25J-15	1	415471504T
PCB-U008	R5245	NF CARBON R	R25J-15	1	415471504T
PCB-U008	R5246	NF CARBON R	R25J-15	1	415471504T
PCB-U008	R5247	NF CARBON R	R25J-15	1	415471504T
PCB-U008	R5248	NF CARBON R	R25J-15	1	415471504T
PCB-U008	R5250	CARBON R	R16J-68K	1	417346834T
PCB-U008	R5251	CARBON R	R16J-68K	1	417346834T
PCB-U008	R5252	CARBON R	R16J-68K	1	417346834T
PCB-U008	R5253	CARBON R	R16J-68K	1	417346834T
PCB-U008	R5254	CARBON R	R16J-68K	1	417346834T
PCB-U008	R5255	CARBON R	R16J-68K	1	417346834T
PCB-U008	R5256	CARBON R	R16J-68K	1	417346834T
PCB-U008	R5257	CARBON R	R16J-68K	1	417346834T
PCB-U008	R5258	CARBON R	R16J-68K	1	417346834T
PCB-U008	R5260	CARBON R	R16J-270K	1	417342744T
PCB-U008	R5261	CARBON R	R16J-270K	1	417342744T

PCB-U008	R5262	CARBON R	R16J-270K	1	417342744T
PCB-U008	R5263	CARBON R	R16J-270K	1	417342744T
PCB-U008	R5264	CARBON R	R16J-270K	1	417342744T
PCB-U008	R5265	CARBON R	R16J-270K	1	417342744T
PCB-U008	R5266	CARBON R	R16J-270K	1	417342744T
PCB-U008	R5267	CARBON R	R16J-270K	1	417342744T
PCB-U008	R5268	CARBON R	R16J-270K	1	417342744T
PCB-U008	R5280	METAL O R	RS1/2WBJ-10K	1	443521034T
PCB-U008	R5281	METAL O R	RS1/2WBJ-10K	1	443521034T
PCB-U008	R5282	METAL O R	RS1/2WBJ-10K	1	443521034T
PCB-U008	R5283	METAL O R	RS1/2WBJ-10K	1	443521034T
PCB-U008	R5284	METAL O R	RS1/2WBJ-10K	1	443521034T
PCB-U008	R5285	METAL O R	RS1/2WBJ-10K	1	443521034T
PCB-U008	R5286	METAL O R	RS1/2WBJ-10K	1	443521034T
PCB-U008	R5287	METAL O R	RS1/2WBJ-10K	1	443521034T
PCB-U008	R5288	METAL O R	RS1/2WBJ-10K	1	443521034T
PCB-U008	R5290	CARBON R	R16J-100K	1	417341044T
PCB-U008	R5291	CARBON R	R16J-100K	1	417341044T
PCB-U008	R5292	CARBON R	R16J-100K	1	417341044T
PCB-U008	R5293	CARBON R	R16J-100K	1	417341044T
PCB-U008	R5294	CARBON R	R16J-100K	1	417341044T
PCB-U008	R5295	CARBON R	R16J-100K	1	417341044T
PCB-U008	R5296	CARBON R	R16J-100K	1	417341044T
PCB-U008	R5297	CARBON R	R16J-100K	1	417341044T
PCB-U008	R5298	CARBON R	R16J-100K	1	417341044T
PCB-U008	R5300	NF CARBON R	R25J-82	1	415478204T
PCB-U008	R5301	NF CARBON R	R25J-82	1	415478204T
PCB-U008	R5302	NF CARBON R	R25J-82	1	415478204T
PCB-U008	R5303	NF CARBON R	R25J-82	1	415478204T
PCB-U008	R5304	NF CARBON R	R25J-82	1	415478204T
PCB-U008	R5305	NF CARBON R	R25J-82	1	415478204T
PCB-U008	R5306	NF CARBON R	R25J-82	1	415478204T
PCB-U008	R5307	NF CARBON R	R25J-82	1	415478204T

PCB-U008	R5308	NF CARBON R	R25J-82	1	415478204T
PCB-U008	R5330	NF CARBON R	R25J-82	1	415478204T
PCB-U008	R5331	NF CARBON R	R25J-82	1	415478204T
PCB-U008	R5332	NF CARBON R	R25J-82	1	415478204T
PCB-U008	R5333	NF CARBON R	R25J-82	1	415478204T
PCB-U008	R5334	NF CARBON R	R25J-82	1	415478204T
PCB-U008	R5335	NF CARBON R	R25J-82	1	415478204T
PCB-U008	R5336	NF CARBON R	R25J-82	1	415478204T
PCB-U008	R5337	NF CARBON R	R25J-82	1	415478204T
PCB-U008	R5338	NF CARBON R	R25J-82	1	415478204T
PCB-U008	R5360	CARBON R	R16J-120K	1	417341244T
PCB-U008	R5361	CARBON R	R16J-120K	1	417341244T
PCB-U008	R5362	CARBON R	R16J-120K	1	417341244T
PCB-U008	R5363	CARBON R	R16J-120K	1	417341244T
PCB-U008	R5364	CARBON R	R16J-120K	1	417341244T
PCB-U008	R5365	CARBON R	R16J-120K	1	417341244T
PCB-U008	R5366	CARBON R	R16J-120K	1	417341244T
PCB-U008	R5367	CARBON R	R16J-120K	1	417341244T
PCB-U008	R5368	CARBON R	R16J-120K	1	417341244T
PCB-U008	R5370	CARBON R	R16J-560K	1	417345644T
PCB-U008	R5371	CARBON R	R16J-560K	1	417345644T
PCB-U008	R5372	CARBON R	R16J-560K	1	417345644T
PCB-U008	R5373	CARBON R	R16J-560K	1	417345644T
PCB-U008	R5374	CARBON R	R16J-560K	1	417345644T
PCB-U008	R5375	CARBON R	R16J-560K	1	417345644T
PCB-U008	R5376	CARBON R	R16J-560K	1	417345644T
PCB-U008	R5377	CARBON R	R16J-560K	1	417345644T
PCB-U008	R5378	CARBON R	R16J-560K	1	417345644T
PCB-U008	R6010	CARBON R	R16J-4.7K	1	417344724T
PCB-U008	R6011	CARBON R	R16J-4.7K	1	417344724T
PCB-U008	R6012	CARBON R	R16J-4.7K	1	417344724T
PCB-U008	R6013	CARBON R	R16J-4.7K	1	417344724T
PCB-U008	R6014	CARBON R	R16J-4.7K	1	417344724T

PCB-U008	R6015	CARBON R	R16J-4.7K	1	417344724T
PCB-U008	R6016	CARBON R	R16J-4.7K	1	417344724T
PCB-U008	R6017	CARBON R	R16J-4.7K	1	417344724T
PCB-U008	R6018	CARBON R	R16J-4.7K	1	417344724T
PCB-U008	R6020	CARBON R	R16J-3.3K	1	417343324T
PCB-U008	R6021	CARBON R	R16J-3.3K	1	417343324T
PCB-U008	R6022	CARBON R	R16J-3.3K	1	417343324T
PCB-U008	R6023	CARBON R	R16J-3.3K	1	417343324T
PCB-U008	R6024	CARBON R	R16J-3.3K	1	417343324T
PCB-U008	R6025	CARBON R	R16J-3.3K	1	417343324T
PCB-U008	R6026	CARBON R	R16J-3.3K	1	417343324T
PCB-U008	R6027	CARBON R	R16J-3.3K	1	417343324T
PCB-U008	R6028	CARBON R	R16J-3.3K	1	417343324T
PCB-U008	R6030	CARBON R	R16J-1.8K	1	417341824T
PCB-U008	R6031	CARBON R	R16J-1.8K	1	417341824T
PCB-U008	R6032	CARBON R	R16J-1.8K	1	417341824T
PCB-U008	R6033	CARBON R	R16J-1.8K	1	417341824T
PCB-U008	R6034	CARBON R	R16J-1.8K	1	417341824T
PCB-U008	R6035	CARBON R	R16J-1.8K	1	417341824T
PCB-U008	R6036	CARBON R	R16J-1.8K	1	417341824T
PCB-U008	R6037	CARBON R	R16J-1.8K	1	417341824T
PCB-U008	R6038	CARBON R	R16J-1.8K	1	417341824T
PCB-U008	R6040	TRIM R	N06HR1KBB	1	5211401T
PCB-U008	R6041	TRIM R	N06HR1KBB	1	5211401T
PCB-U008	R6042	TRIM R	N06HR1KBB	1	5211401T
PCB-U008	R6043	TRIM R	N06HR1KBB	1	5211401T
PCB-U008	R6044	TRIM R	N06HR1KBB	1	5211401T
PCB-U008	R6045	TRIM R	N06HR1KBB	1	5211401T
PCB-U008	R6046	TRIM R	N06HR1KBB	1	5211401T
PCB-U008	R6047	TRIM R	N06HR1KBB	1	5211401T
PCB-U008	R6048	TRIM R	N06HR1KBB	1	5211401T
PCB-U008	R6050	CARBON R	R16J-2.7K	1	417342724T
PCB-U008	R6051	CARBON R	R16J-2.7K	1	417342724T



PCB-U008	R6052	CARBON R	R16J-2.7K	1	417342724T
PCB-U008	R6053	CARBON R	R16J-2.7K	1	417342724T
PCB-U008	R6054	CARBON R	R16J-2.7K	1	417342724T
PCB-U008	R6055	CARBON R	R16J-2.7K	1	417342724T
PCB-U008	R6056	CARBON R	R16J-2.7K	1	417342724T
PCB-U008	R6057	CARBON R	R16J-2.7K	1	417342724T
PCB-U008	R6058	CARBON R	R16J-2.7K	1	417342724T
PCB-U008	R6060	NF CARBON R	R25J-120	1	415471214T
PCB-U008	R6061	NF CARBON R	R25J-120	1	415471214T
PCB-U008	R6062	NF CARBON R	R25J-120	1	415471214T
PCB-U008	R6063	NF CARBON R	R25J-120	1	415471214T
PCB-U008	R6064	NF CARBON R	R25J-120	1	415471214T
PCB-U008	R6065	NF CARBON R	R25J-120	1	415471214T
PCB-U008	R6066	NF CARBON R	R25J-120	1	415471214T
PCB-U008	R6067	NF CARBON R	R25J-120	1	415471214T
PCB-U008	R6068	NF CARBON R	R25J-120	1	415471214T
PCB-U008	R6070	NF CARBON R	R25J-82	1	415478204T
PCB-U008	R6071	NF CARBON R	R25J-82	1	415478204T
PCB-U008	R6072	NF CARBON R	R25J-82	1	415478204T
PCB-U008	R6073	NF CARBON R	R25J-82	1	415478204T
PCB-U008	R6074	NF CARBON R	R25J-82	1	415478204T
PCB-U008	R6075	NF CARBON R	R25J-82	1	415478204T
PCB-U008	R6076	NF CARBON R	R25J-82	1	415478204T
PCB-U008	R6077	NF CARBON R	R25J-82	1	415478204T
PCB-U008	R6078	NF CARBON R	R25J-82	1	415478204T
PCB-U008	R6110	CARBON R	R16J-10K	1	417341034T
PCB-U008	R6111	CARBON R	R16J-10K	1	417341034T
PCB-U008	R6112	CARBON R	R16J-10K	1	417341034T
PCB-U008	R6113	CARBON R	R16J-10K	1	417341034T
PCB-U008	R6114	CARBON R	R16J-10K	1	417341034T
PCB-U008	R6115	CARBON R	R16J-10K	1	417341034T
PCB-U008	R6116	CARBON R	R16J-10K	1	417341034T
PCB-U008	R6117	CARBON R	R16J-10K	1	417341034T

PCB-U008	R6118	CARBON R	R16J-10K	1	417341034T
PCB-U008	R6250	NF CARBON R	R25J-120	1	415471214T
PCB-U008	R6251	NF CARBON R	R25J-120	1	415471214T
PCB-U008	R6252	NF CARBON R	R25J-120	1	415471214T
PCB-U008	R6253	NF CARBON R	R25J-120	1	415471214T
PCB-U008	R6254	NF CARBON R	R25J-120	1	415471214T
PCB-U008	R6255	NF CARBON R	R25J-120	1	415471214T
PCB-U008	R6256	NF CARBON R	R25J-120	1	415471214T
PCB-U008	R6257	NF CARBON R	R25J-120	1	415471214T
PCB-U008	R6258	NF CARBON R	R25J-120	1	415471214T
PCB-U008	R6260	NF CARBON R	R25J-120	1	415471214T
PCB-U008	R6261	NF CARBON R	R25J-120	1	415471214T
PCB-U008	R6262	NF CARBON R	R25J-120	1	415471214T
PCB-U008	R6263	NF CARBON R	R25J-120	1	415471214T
PCB-U008	R6264	NF CARBON R	R25J-120	1	415471214T
PCB-U008	R6265	NF CARBON R	R25J-120	1	415471214T
PCB-U008	R6266	NF CARBON R	R25J-120	1	415471214T
PCB-U008	R6267	NF CARBON R	R25J-120	1	415471214T
PCB-U008	R6268	NF CARBON R	R25J-120	1	415471214T
PCB-U008	R6270	NF CARBON R	R25J-18	1	415471804T
PCB-U008	R6271	NF CARBON R	R25J-18	1	415471804T
PCB-U008	R6272	NF CARBON R	R25J-18	1	415471804T
PCB-U008	R6273	NF CARBON R	R25J-18	1	415471804T
PCB-U008	R6274	NF CARBON R	R25J-18	1	415471804T
PCB-U008	R6275	NF CARBON R	R25J-18	1	415471804T
PCB-U008	R6276	NF CARBON R	R25J-18	1	415471804T
PCB-U008	R6277	NF CARBON R	R25J-18	1	415471804T
PCB-U008	R6278	NF CARBON R	R25J-18	1	415471804T
PCB-U008	R6280	NF CARBON R	R25J-18	1	415471804T
PCB-U008	R6281	NF CARBON R	R25J-18	1	415471804T
PCB-U008	R6282	NF CARBON R	R25J-18	1	415471804T
PCB-U008	R6283	NF CARBON R	R25J-18	1	415471804T
PCB-U008	R6284	NF CARBON R	R25J-18	1	415471804T

PCB-U008	R6285	NF CARBON R	R25J-18	1	415471804T	
PCB-U008	R6286	NF CARBON R	R25J-18	1	415471804T	
PCB-U008	R6287	NF CARBON R	R25J-18	1	415471804T	
PCB-U008	R6288	NF CARBON R	R25J-18	1	415471804T	
PCB-U008	R6290	NF CARBON R	R25J-2.2	1	415470224T	
PCB-U008	R6291	NF CARBON R	R25J-2.2	1	415470224T	
PCB-U008	R6292	NF CARBON R	R25J-2.2	1	415470224T	
PCB-U008	R6293	NF CARBON R	R25J-2.2	1	415470224T	
PCB-U008	R6294	NF CARBON R	R25J-2.2	1	415470224T	
PCB-U008	R6295	NF CARBON R	R25J-2.2	1	415470224T	
PCB-U008	R6296	NF CARBON R	R25J-2.2	1	415470224T	
PCB-U008	R6297	NF CARBON R	R25J-2.2	1	415470224T	
PCB-U008	R6298	NF CARBON R	R25J-2.2	1	415470224T	
PCB-U008	R6300	NF CARBON R	R25J-2.2	1	415470224T	
PCB-U008	R6301	NF CARBON R	R25J-2.2	1	415470224T	
PCB-U008	R6302	NF CARBON R	R25J-2.2	1	415470224T	
PCB-U008	R6303	NF CARBON R	R25J-2.2	1	415470224T	
PCB-U008	R6304	NF CARBON R	R25J-2.2	1	415470224T	
PCB-U008	R6305	NF CARBON R	R25J-2.2	1	415470224T	
PCB-U008	R6306	NF CARBON R	R25J-2.2	1	415470224T	
PCB-U008	R6307	NF CARBON R	R25J-2.2	1	415470224T	
PCB-U008	R6308	NF CARBON R	R25J-2.2	1	415470224T	
PCB-U008	R6310	NF CARBON R	R25J-10	1	415471004T	
PCB-U008	R6311	NF CARBON R	R25J-10	1	415471004T	
PCB-U008	R6312	NF CARBON R	R25J-10	1	415471004T	
PCB-U008	R6313	NF CARBON R	R25J-10	1	415471004T	
PCB-U008	R6314	NF CARBON R	R25J-10	1	415471004T	
PCB-U008	R6315	NF CARBON R	R25J-10	1	415471004T	
PCB-U008	R6316	NF CARBON R	R25J-10	1	415471004T	
PCB-U008	R6317	NF CARBON R	R25J-10	1	415471004T	
PCB-U008	R6318	NF CARBON R	R25J-10	1	415471004T	
PCB-U008	[SW TRM]					
PCB-U008	P001	PWB	BCCLA-0226	1	25140226C	N

PCB-U008	P002	PWB	BCCLA-0227	{ 1 }	25140227	N
PCB-U008	P003	PWB	BCCLA-0228	{ 1 }	25140228	N
PCB-U008	P004	PWB	BCCLA-0229	{ 1 }	25140229	N
PCB-U008	P005	PWB	BCCLA-0230	{ 1 }	25140230	N
PCB-U008	P006	PWB	BCCLA-0231	{ 1 }	25140231	N
PCB-U008	P007	PWB	BCCLA-0232	{ 1 }	25140232	N
PCB-U008	P008	PWB	BCCLA-0233	{ 1 }	25140233	N
PCB-U008	P009	PWB	BCCLA-0234	{ 1 }	25140234	N
PCB-U008	P5010A	SOCKET	NSCT-3P2183	1	25052286	
PCB-U008	P5011A	SOCKET	NSCT-3P2183	1	25052286	
PCB-U008	P5012A	SOCKET	NSCT-3P2183	1	25052286	
PCB-U008	P5013A	SOCKET	NSCT-3P2183	1	25052286	
PCB-U008	P5014A	SOCKET	NSCT-3P2183	1	25052286	
PCB-U008	P5015A	SOCKET	NSCT-3P2183	1	25052286	
PCB-U008	P5016A	SOCKET	NSCT-3P2183	1	25052286	
PCB-U008	P5017A	SOCKET	NSCT-3P2183	1	25052286	
PCB-U008	P5018A	SOCKET	NSCT-3P2183	1	25052286	
PCB-U008	P5020A	TRM	NTM-1P233(M1969)	1	25060302	
PCB-U008	P5021A	TRM	NTM-1P233(M1969)	1	25060302	
PCB-U008	P5022A	TRM	NTM-1P233(M1969)	1	25060302	
PCB-U008	P5023A	TRM	NTM-1P233(M1969)	1	25060302	
PCB-U008	P5024A	TRM	NTM-1P233(M1969)	1	25060302	
PCB-U008	P5025A	TRM	NTM-1P233(M1969)	1	25060302	
PCB-U008	P5026A	TRM	NTM-1P233(M1969)	1	25060302	
PCB-U008	P5027A	TRM	NTM-1P233(M1969)	1	25060302	
PCB-U008	P5028A	TRM	NTM-1P233(M1969)	1	25060302	
PCB-U008	P6010A	SOCKET	NSCT-3P2183	1	25052286	
PCB-U008	P6011A	SOCKET	NSCT-3P2183	1	25052286	
PCB-U008	P6012A	SOCKET	NSCT-3P2183	1	25052286	
PCB-U008	P6013A	SOCKET	NSCT-3P2183	1	25052286	
PCB-U008	P6014A	SOCKET	NSCT-3P2183	1	25052286	
PCB-U008	P6015A	SOCKET	NSCT-3P2183	1	25052286	
PCB-U008	P6016A	SOCKET	NSCT-3P2183	1	25052286	

PCB-U008	P6017A	SOCKET	NSCT-3P2183	1	25052286	
PCB-U008	P6018A	SOCKET	NSCT-3P2183	1	25052286	
PCB-U008	P6030B	SOCKET	IMSA-9115S-05L	1	25052985	N
PCB-U008	P6031B	SOCKET	IMSA-9115S-05L	1	25052985	N
PCB-U008	P6032B	SOCKET	IMSA-9115S-05L	1	25052985	N
PCB-U008	P6033B	SOCKET	IMSA-9115S-05L	1	25052985	N
PCB-U008	P6034B	SOCKET	IMSA-9115S-05L	1	25052985	N
PCB-U008	P6035B	SOCKET	IMSA-9115S-05L	1	25052985	N
PCB-U008	P6036B	SOCKET	IMSA-9115S-05L	1	25052985	N
PCB-U008	P6037B	SOCKET	IMSA-9115S-05L	1	25052985	N
PCB-U008	P6038B	SOCKET	IMSA-9115S-05L	1	25052985	N
PCB-U010	<b>U0101</b> FRONT HDMI PC BOARD (BAHDM-0291-1B)					
PCB-U010						
PCB-U010	<b>CIRCUIT. PART NAME</b>	<b>DESCRIPTION</b>		<b>Q'TY</b>	<b>PART NO. (SN)</b>	<b>REMARKS</b>
PCB-U010	<b>[SEMI CONDUCTOR]</b>					
PCB-U010	D3300	C-DIODE	KDS4148U	1	223283R2	
PCB-U010	D3300 or	C-DIODE	1SS352	(1)	223234R2	
PCB-U010	D3301	C-DIODE	KDS4148U	1	223283R2	
PCB-U010	D3301 or	C-DIODE	1SS352	(1)	223234R2	
PCB-U010	D8861	C-DIODE	KDS4148U	1	223283R2	
PCB-U010	D8861 or	C-DIODE	1SS352	(1)	223234R2	
PCB-U010	D8862	C-DIODE	KDS4148U	1	223283R2	
PCB-U010	D8862 or	C-DIODE	1SS352	(1)	223234R2	
PCB-U010	Q3300	IC	TPD2E001DRLR	1	22242589R2	
PCB-U010	Q8861	IC	TMDS141RHARG4	1	22242586R2	
PCB-U010	<b>[TRANS COIL]</b>					
PCB-U010	L8861	CORE	BLM18PG181SN1D	1	2350005R1	
PCB-U010	<b>[CAPACITOR]</b>					
PCB-U010	C3302	C-FILM C	ECHU16V-104J	1	373041044R2	
PCB-U010	C3303	C-FILM C	ECHU16V-104J	1	373041044R2	
PCB-U010	C3304	C-CERA C	CK725F1A-105Z1	1	332181050R1	
PCB-U010	C8861	C-FILM C	ECHU16V-104J	1	373041044R2	

PCB-U010	C8863	C-CERA C	CK725F1A-105Z1	1	332181050R1	
PCB-U010	C8864	C-CERA C	CK725B1H-102K1	1	332101025R1	
PCB-U010	C8869	C-CERA C	CK725F1A-105Z1	1	332181050R1	
PCB-U010	C8870	C-CERA C	CK725B1H-102K1	1	332101025R1	
PCB-U010	C8871	C-CERA C	CK725F1A-105Z1	1	332181050R1	
PCB-U010	C8872	C-CERA C	CK725B1H-102K1	1	332101025R1	
PCB-U010	C8873	C-CERA C	CK725F1A-105Z1	1	332181050R1	
PCB-U010	C8874	C-CERA C	CK725B1H-102K1	1	332101025R1	
PCB-U010	C8875	C-CERA C	CK725F1A-105Z1	1	332181050R1	
PCB-U010	C8876	C-CERA C	CK725B1H-102K1	1	332101025R1	
PCB-U010	C8877	C-CERA C	CK725B0J-106K	1	332091065R2	
PCB-U010	C8880	C-CERA C	CK725B0J-106K	1	332091065R2	
PCB-U010	<b>[RESISTOR]</b>					
PCB-U010	R3331	C-CARBON R	RN72K1J-000JE	1	435030004R1	
PCB-U010	R8867	C-CARBON R	RN72K1J-473JE	1	435034734R1	
PCB-U010	R8868	C-CARBON R	RN72K1J-473JE	1	435034734R1	
PCB-U010	R8869	C-CARBON R	RN72K1J-000JE	1	435030004R1	
PCB-U010	R8870	C-CARBON R	RN72K1J-000JE	1	435030004R1	
PCB-U010	R8872	C-CARBON R	RN72K1J-103JE	1	435031034R1	
PCB-U010	R8873	C-CARBON R	RN72K1J-472JE	1	435034724R1	
PCB-U010	R8874	C-CARBON R	RN72K1J-103JE	1	435031034R1	
PCB-U010	R8875	C-CARBON R	RN72K1J-103JE	1	435031034R1	
PCB-U010	R8876	C-CARBON R	RN72K1J-103JE	1	435031034R1	
PCB-U010	R8880	C-CARBON R	RN72K1J-000JE	1	435030004R1	
PCB-U010	R8881	C-CARBON R	RN72K1J-000JE	1	435030004R1	
PCB-U010	<b>[SW TRM]</b>					
PCB-U010	E8861	TRM	NTM-1P233(M1969)	1	25060302	
PCB-U010	P010	PWB	BCHDM-0290	1	25140290B	N
PCB-U010	P011	PWB	BCHDM-0291	{ 1 }	25140291	
PCB-U010	P3101C	PLUG	NPLG-5P918	1	25055965R2	
PCB-U010	P3305	SOCKET	YKF45-0029N	1	25053242	
PCB-U010	P8641D	SOCKET	FX16-31S-0.5SV	1	25053354R2	
PCB-U010	P8861	SOCKET	YKF45-7037V	1	25053253R3	

TX-NR3007

## PACKING PROCEDURE PARTS LIST

	REF. NO.	PART NAME	DESCRIPTION	Q'TY	PART NO. (SN)	REMARKS
PACKING		[PACKING]				
EXPLODED	A615	TAPE	FIXLON #817 W12	1	29110207	
EXPLODED	A615 or	TAPE	SLIONTEC 9514	( 1)	29110201	
EXPLODED	A616	CUSHION	EPE t2.5x40x20	2	28141827	
EXPLODED	A617	INST SHEET	txnr807 door	1	29355770	
PACKING	A701	SHEET	T0.515 x 1300 x 900	1	29096066	
PACKING	A705	POLY BAG	(W1020 x D770)	1	29100253	
PACKING	A706	POLY BAG	w500 x d650	1	29100249	
PACKING	A707	TAPE	NITTO NO.29	1	29110149	
PACKING	A711	CARTON	3007DC	1	29055040B	N <MDC>
PACKING	A711	CARTON	3007	1	29055041C	N <MMO, MMP>
PACKING	A715	PAD	AS	1	29092479B	
PACKING	A717	SHEET	(ACC)	1	29096104	
PACKING	A719	STAPLE	FUKAN-BARI (1000KO)	4	282321	
PACKING	A721	PP TAPE	W50 SBT-70	1	29110200	
PACKING	A751A	UPC LABEL	3007BMDC	1	29390910	N (B) <MDC>
PACKING	A751A	EAN LABEL	3007BMMP	1	29390911	N (B) <MMP>
PACKING	A751A	EAN LABEL	3007SMMP	1	29390912	N (S)
PACKING	A751A	EAN LABEL	3007BMMO	1	29390914	N (B) <MMO>
PACKING	A761	POLY BAG	---	1	29100225A	<MMO>
PACKING	A761or	POLY BAG	w250 x d350	( 1)	29100250A	<MMO>
PACKING	A771	WRNTY CARD	(ONKYO)	1	29365135	<MDC>
PACKING	A838	INS MANUAL	U3EnFrEs(SIRIUS)	1	29400030B	<MDC>
PACKING		[ACCESSARY]				
PACKING	A808	INS MANUAL	En(TX-NR3007/5007)	1	29400059	N
PACKING	A809	INS MANUAL	U2FrEs(TX-NR3007/5007)	1	29400060	N <MDC, MMP>
PACKING	A810	INS MANUAL	U2IfDe(TX-NR3007/5007)	1	29400061	N <MMP>

PACKING	A812	INS MANUAL	Ru (TX-NR3007/5007)	1	29400063	N <MMP>
PACKING	A811	INS MANUAL	U2NISv(TX-NR3007/5007)	1	29400062	N <MMP>
PACKING	A813	INS MANUAL	Ct(TX-NR3007/5007)	1	29400064	N <MMO>
PACKING	A814	INS MANUAL	Ar(TX-NR3007)	1	29400065	N <MMO>
PACKING	A820	INS MANUAL	En(QSS_TX-NR3007/5007)	1	29400071	N
PACKING	A829	INS MANUAL	(QC ImportantSheet)	1	29344267A	<MMO>
PACKING	A830	INST SHEET	WEEE	1	29355537A	<MMP>
PACKING	A831	HANDBILL	(SIRIUS)	1	29380149	<MDC>
PACKING	A832	INST SHEET	En(2009E_RIHD)	1	29355745	
PACKING	A833	INST SHEET	U2FrEs(2009E_RIHD)	1	29355746	<MDC>
PACKING	A834	INST SHEET	U8(2009E_RIHD)	1	29355747	<MMO, MMP>
PACKING	A837	INS MANUAL	U9(RC736/737/738/739)	1	29344962	
PACKING	A839	INS MANUAL	U2JaEn(Software_807/HT-RC180)	1	29400164	
PACKING	A840	INS MANUAL	U3EnFrEs(Pand/Rhap/InSir_ONK)	1	29400165	<MDC>
PACKING	A841	INS MANUAL	U2EnDe(last.fm_807/HT-RC180)	1	29400166	<MMP>
PACKING	A847	INST SHEET	WINDOWS7	1	29355775	
PACKING	A852	LABEL	(SPCABLE)2009	1	29390881	
PACKING	A853	HANDBILL	(UP-A1)US	1	29380155	<MDC>
PACKING	A853	HANDBILL	(UP-A1)EU	1	29380156	<MMP>
PACKING	A861	POLY BAG	w250 x d350	1	29100250A	
PACKING	A863	POLY BAG	w250 x d350	1	29100250A	<MDC>
PACKING	A863	POLY BAG	w250 x d350	2	29100250A	<MMP>
PACKING	A890	REMO CON	RC-747M	1	24140747	
PACKING	A891	BATTERY	R6/AA(UM-3)	2	3010194	
PACKING	A891 or	BATTERY	R6/AA(UM-3)	(2)	3010054	
PACKING	A892	ANT COIL	NMA-3057	1	232140	
PACKING	A893	FM ANT AS	Type W	1	292191	
PACKING	A894	MIC	MIC-7000	1	245044	
PACKING	P901	AC CORD	AS-CEE-3	1	253298VOL	!, <MMO, MMP>
PACKING	P901	AC CORD	AS-UC-2	1	253301VOL	!, <MDC>
PACKING	P902	CV PLUG	SCP-13A-BLK(UK)	1	25056591	!, <MMO>



---

**ONKYO CORPORATION**

Service Dept. Technical Support : 2-1, Nisshin-cho, Neyagawa-shi, OSAKA 572-8540, JAPAN  
Tel: 072-831-8023 Fax: 072-831-8163

**ONKYO U.S.A. CORPORATION**

18 Park Way, Upper Saddle River, N.J. 07458, U.S.A.  
Tel: 201-785-2600 Fax: 201-785-2650 <http://www.us.onkyo.com/>

**ONKYO EUROPE ELECTRONICS GmbH (DUISBURG OFFICE)**

Hafennr.7602, Logport Office-Center, Bliersheimerstr.80B, 47229 Duisburg, Germany  
Tel: +49-2065-90198-00 Fax: +49-2065-90198-40 <http://www.eu.onkyo.com/>

**ONKYO EUROPE UK Office**

Suite 1, Gregories Court, Gregories Road, Beaconsfield, Buckinghamshire, HP9 1HQ  
UNITED KINGDOM Tel: +44-(0)1494-681515 Fax: +44(0)-1494-680452

**ONKYO CHINA LIMITED**

Units 2102-2107, Metroplaza Tower I, 223 Hing Fong Road, Kwai Chung,  
N.T., HONG KONG Tel: 852-2429-3118 Fax: 852-2428-9039  
<http://www.ch.onkyo.com/>

