

AV Receiver

Service Manual

TX-NR555

- ✓ Pre Issue (2016-Mar)
- ✓ Final Issue (2016-Jun)

CONTENTS

- ✓ [Title Page \(This page\)](#)
- ✓ [Note for Parts List](#)
- ✓ [Panel](#)
- ✓ [Reset](#)
- ✓ [Amp Diag Mode after Abnormal Conditions](#)
- ✓ [Model and Destination](#)
- ✓ [WiFi 5GHz Setting](#)
- ✓ [Firmware](#)
- ✓ [Adjustment](#)
- ✓ [Hookup and Setting](#)
- ✓ [Trouble Shoot](#)
- ✓ [Disassembly](#)
- ✓ [Schematic Diagram](#)
- ✓ [Exploded View](#)
- ✓ [Appendix](#)



SAFETY-RELATED COMPONENT WARNING!! : COMPONENTS IDENTIFIED BY MARK  ON THE SCHEMATIC DIAGRAM AND IN THE PARTS LIST ARE CRITICAL FOR RISK OF FIRE AND ELECTRIC SHOCK. REPLACE THESE COMPONENTS WITH ONKYO PARTS WHOSE PART NUMBERS APPEAR AS SHOWN IN THIS MANUAL. MAKE LEAKAGE-CURRENT OR RESISTANCE MEASUREMENTS TO DETERMINE THAT EXPOSED PARTS ARE ACCEPTABLY INSULATED FROM THE SUPPLY CIRCUIT BEFORE RETURNING THE APPLIANCE TO THE CUSTOMER.

ONKYO®

Published by Onkyo & Pioneer Corporation Global CS Department

File Name of Parts List File (EXCEL File)

Note for Parts List

When parts list is EXCEL file, please refer to the following explanation about file name.

P L _ **T X - S R 3 4 3** (**B**) M **J J** . x l s x

Model No.

Color

Destination (仕向地記号)

Look at the rear panel serial number 6 digit.

○ ○ ○ ○ ○ J ○ ○ ○ ○ ○ ○ ○ ○ ○ ○

Voltage (電圧記号)

Look at the rear panel serial number 5 digit.

○ ○ ○ ○ J ○ ○ ○ ○ ○ ○ ○ ○ ○ ○

Color (色記号)	
(X)	Not related to color
(B)	Black
(BR)	Brown
(C)	Cherry
(G)	Gold
(GR)	Green
(H)	Gray
(K)	Black
(L)	Blue
(LB)	Light Blue
(M)	Wood
(O)	Orange
(P)	Pink
(R)	Red
(S)	Silver
(V)	Violet
(W)	White
(Y)	Yellow

Voltage (電圧記号)	
D	120V AC
G	220~230V
H	220~230/240V
J	100V AC
M	220~240V AC
P	230V AC
U	100~240V AC
V	110~240V
W	120V/220~240V
Speaker System (without AMP.) :	
0	Passive Subwoofer
F	Front Speaker
C	Center Speaker
R	Rear Speaker
B	Back Speaker

Destination (仕向地記号)	
A	Australia
B	United Kingdom
C	North American
D	USA
F	Taiwan
J	Japan
K	Korea
L	Russia
P	Europe
Q	Hong Kong
R	China
S	Brazil
T	Thai
U	Worldwide
Speaker System (without AMP.) :	
L	Left channel
R	Right channel
0	Center channel

MUSIC OPTIMIZER button/indicator (North American models): Turns on/off the Music Optimizer function that provides better sound quality for compressed audio.

PURE AUDIO button/indicator (European, Australian and Asian models): Switches the unit to Pure Audio mode.

Front Panel

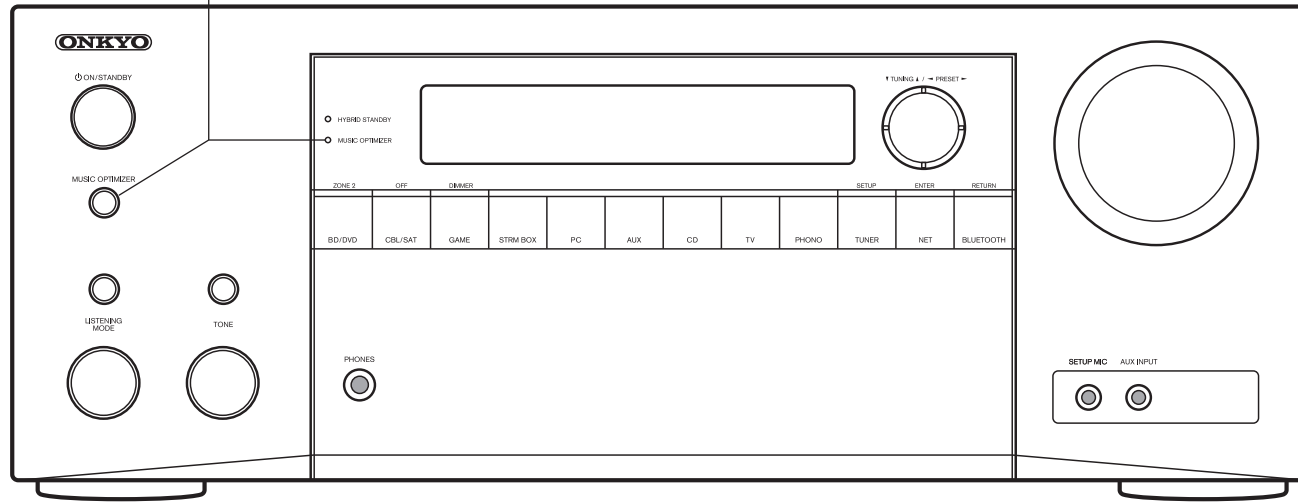

Remote Control Unit RC-911R

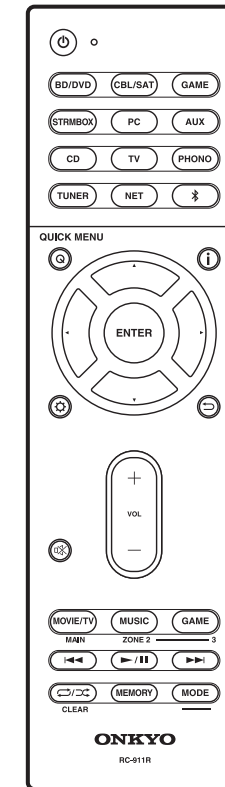

Rear Panel

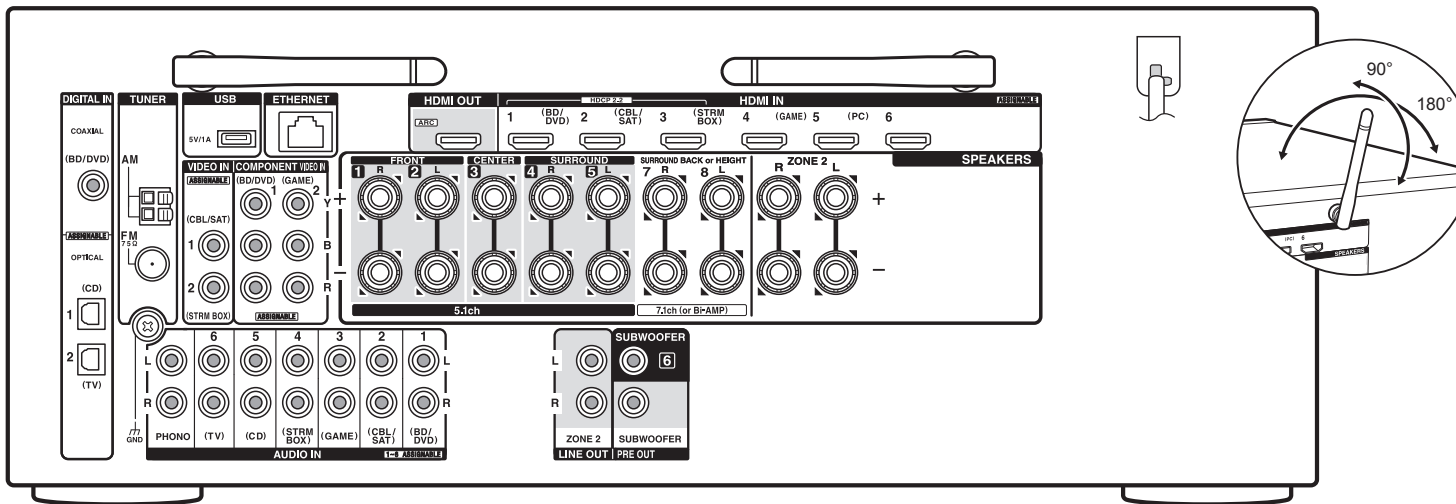

Accessories

1. Remote controller (RC-911R) ×1
Batteries (AAA/R03) ×2 (Except MMR type)
2. Indoor FM antenna ×1
3. AM loop antenna ×1
4. Speaker setup microphone ×1
5. FM Isolator x1 (MMR type only)

Dimensions (W × H × D) : 435 mm × 173.5 mm × 378 mm, 17-1/8" × 6-13/16" × 14-7/8"
Weight : 9.4 kg (20.7 lbs.) (North American), 9.6 kg (21.2 lbs.) (Others)

How to Reset the Unit

Reset

Step1. STORE (To save user preferences.)

While pressing [SETUP] button, press [ENTER] button twice.

Step2. RESET

While pressing [CBL] or [CBL/SAT] button, press [ON/STANDBY] button.

※) "Clear" appears on the display and the unit returns to standby. Do not unplug the power cord until "Clear" disappears from the display.

Step3. RECALL (To load user preferences.)

While pressing [SETUP] button, press [RETURN] button twice.

Standard Knob Position (S.K.P.)	
Master Volume Control	40dB
Input Selector	BD/DVD
Muting	Off
Listening Mode	All Ch Stereo
Subwoofer	Yes
Front Left Level	0 dB
Front Right Level	0 dB
Center Level	0 dB
Left Surround Level	0 dB
Right Surround Level	0 dB
Subwoofer Level	0 dB

TX-NR555/656/757
TX-RZ610/710/810
HT-R695
DRX-2/3/4/5

Protect Mode

Amp Diag Mode after Abnormal Conditions

The unit goes into standby automatically when detect the abnormal condition of thermal detection, dc voltage detection or current detection. (e.g. TX-NR555 block diagram below)

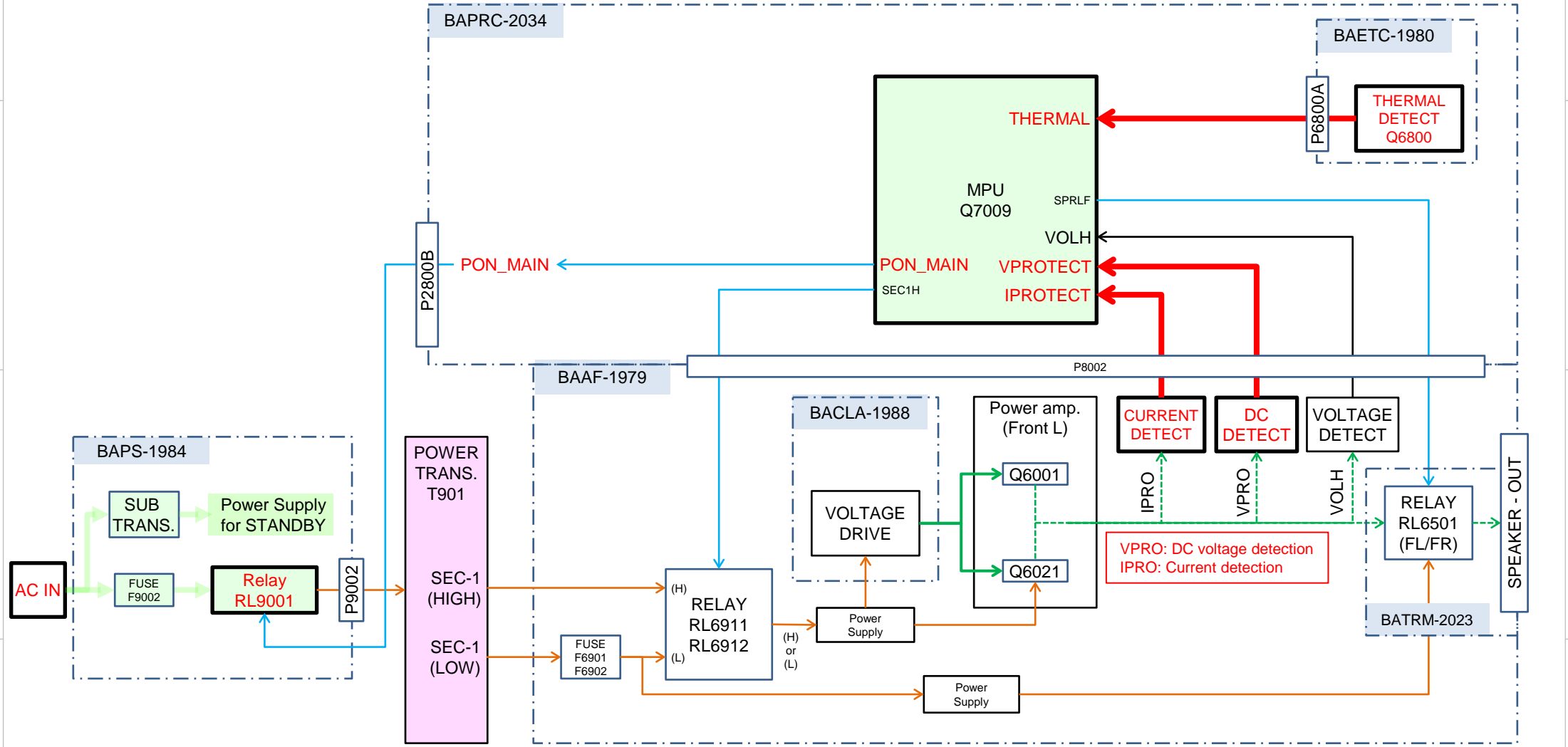

Self-diagnostics

This function is for avoiding the rupture of electrolytic capacitors with amplifier circuit failure during power-ON.

Operation of Self-diagnostic

Self-diagnostic will start at the timing of next power on, after goes to the protect mode by Current detection or DC voltage detection.

Only On/Standby key could work in this mode. Also remote control does not work. However, the CLEAR operation is enabled.

During Self-diagnostic, the power supply for amplifier circuit become low voltage state(SEC1-LOW), and the speaker relay will be turned off. Then, MPU will check each amplifier circuits Internally by entering the test signal (20 kHz,-20 dBFS sine wave) to each channel from DSP.

MPU will judge the amplifier circuit is good or not from VOLH value.

The normal range of VOLH value is $0.04\text{ V} < \text{VOLH} < 0.20\text{ V}$.

If VOLH value is in the out of this range, it will be judged as NG (No good).

No problem found

When protected by current detection, and no problem found, "CHECK SP WIRE" will be displayed. In this State, Only the On/Standby key is effective. And if do not anything for 3 minutes, unit goes into standby automatically.

When protected by a DC voltage detection, and no problem found, unit goes into normal operation.

Problem found

When judged as there is a problem on any channel, the information of channel that has a problem will be displayed as in the right figure.

In this State, Only the On/Standby key is effective. Also remote control does not work. If do not anything for 3 minutes, unit goes into standby automatically. This state will keep also after unit turn on/off, or AC unplugged.

the power supply for amplifier circuit become low voltage state(SEC1-LOW), and the speaker relay will be turned off.

Amp Diag Mode after Abnormal Conditions

Display of during Self-diagnostics

2 Line FL tube type

A	M	P		D	i	a	g		M	o	d	e	

1 Line FL tube type

A	M	P		D	i	a	g		M	o	d	e	
---	---	---	--	---	---	---	---	--	---	---	---	---	--

"Mode" This part display the channel which is currently checked. (E.g. "[FL]", etc.)

Display of when problem found

2 Line FL tube type

N	G		C	H	:								
			L	C	R	S	L	S	R	B	L	B	R

1 Line FL tube type

N	G	:	L	C	R	S	L	S	R	B	L	B	R
---	---	---	---	---	---	---	---	---	---	---	---	---	---

- L** → Front L channel **S L** → Surround L channel
- C** → Center channel **S R** → Surround R channel
- R** → Front R channel **B L** → Surround back L channel
- B R** → Surround back R channel

Repair Process and How to Confirm

Confirmation of the protect cause

While NG channel is displayed, You can confirm the protect cause by following the step below.

1. Press the Enter button
2. The protect cause are displayed for 5 seconds.

Please check the around of those amplifier circuit and repair it.

Clear of NG CH information

After repair, you can clear NG CH information by following the steps below.

1. Press the On/Standby key while pressing the Enter key.
2. Display as in the right figure appears.
3. Unit goes into Standby automatically after 5 seconds.

Self-diagnostic will start again at the timing of next power on.

By this, You can verify whether repair was properly or not.

If problem found after repair, please re-check the around of its circuit.

Cancel of Self-diagnostic

You can cancel this mode by clear operation (press Standby key while pressing CBL/SAT key).

After cancel this mode, receiver will be started as normal operation.

Manual Execution of Self-diagnostic

1. [DIMMER] + [ON/STANDBY] x 2

Main Firmware Version will appear on the main unit's display.

2. [SETUP] or [HOME]

[Service information](#) will appear on the main unit's display

3. [ENTER]

Display as in the right figure appears.

4. [STANDBY/ON]

Unit will go into standby.

5. [STANDBY/ON]

Unit will turn on. Then self-diagnostic will start automatically.

Amp Diag Mode after Abnormal Conditions

Protected by current detection

D E T . P R O T E C T : I

Protected by DC Voltage detection

D E T . P R O T E C T : V

Clear of NG CH information

N G C H C L E A R

Manual Execution of Self-diagnostic

A M P D I A G T E S T O N

How to check model and destination

Model and Destination

Step1 :

Set VOL Level = 40

Step2 :

[List-D(※)] + [ON/STANDBY] → [DIMMER] → [List-B(※)] x 5

※) Refer to [Model List](#).

Model Name	Destination	FL Display													
TX-NR555	DC	N	R	5	5	5			D	C		0	0	0	0
TX-NR555	xx	N	R	5	5	5			x	x		0	0	1	0
TX-NR555	xA	N	R	5	5	5			x	A		0	0	4	0
TX-NR555	xR	N	R	5	5	5			x	R		0	0	5	0
DRX-2	DD	D	R	X	-	2			D	D		1	0	0	0
DRX-2	xx	D	R	X	-	2			x	x		1	0	1	0
DRX-2	xA	D	R	X	-	2			x	A		1	0	4	0
DRX-2	xR	D	R	X	-	2			x	R		1	0	5	0
TX-NR656	DC	N	R	6	5	6			D	C		0	1	0	0
TX-NR656	DF	N	R	6	5	6			D	F		0	1	3	0
TX-NR656	xx	N	R	6	5	6			x	x		0	1	1	0
TX-NR656	xA	N	R	6	5	6			x	A		0	1	4	0
TX-NR656	xR	N	R	6	5	6			x	R		0	1	5	0
TX-NR656	JJ	N	R	6	5	6			J	J		0	1	2	0
HT-R695	DC	R	6	9	5				D	C		0	1	0	2
HT-R695	xx	R	6	9	5				x	x		0	1	1	2
TX-RZ610	DC	R	Z	6	1	0			D	C		0	1	0	1
DRX-3	DD	D	R	X	-	3			D	D		1	1	0	0
DRX-3	xx	D	R	X	-	3			x	x		1	1	1	0
DRX-3	xA	D	R	X	-	3			x	A		1	1	4	0
DRX-3	xR	D	R	X	-	3			x	R		1	1	5	0
DRX-3	JJ	D	R	X	-	3			J	J		1	1	2	0

Model Name	Destination	FL Display													
TX-RZ710	DC	R	Z	7	1	0			D	C		0	2	0	0
TX-RZ710	xx	R	Z	7	1	0			x	x		0	2	1	0
TX-RZ710	xA	R	Z	7	1	0			x	A		0	2	4	0
TX-RZ710	xR	R	Z	7	1	0			x	R		0	2	5	0
DRX-4	DD	D	R	X	-	4			D	D		1	2	0	0
DRX-4	xx	D	R	X	-	4			x	x		1	2	1	0
TX-NR757	DC	N	R	7	5	7			D	C		0	4	0	0
TX-RZ810	DC	R	Z	8	1	0			D	C		0	3	0	0
TX-RZ810	xx	R	Z	8	1	0			x	x		0	3	1	0
TX-RZ810	xA	R	Z	8	1	0			x	A		0	3	4	0
TX-RZ810	xR	R	Z	8	1	0			x	R		0	3	5	0
TX-RZ810	JJ	R	Z	8	1	0			J	J		0	3	2	0
DRX-5	DD	D	R	X	-	5			D	D		1	3	0	0
DRX-5	xx	D	R	X	-	5			x	x		1	3	1	0

This list is MCU internal value,
And The destination code of this list,
it is different from Wi-Fi 5GHz setting Destination Code

TX-NR555/NR656
HT-R695
TX-RZ610
DRX-2/3

IMPORTANT!!

Back Ground:

It is totally different from Radio Law at the each country on 5GHz band.
It means it is totally different from enabled Channel of 5GHz band at the each country.
We define the “[Country Code](#)” for 5GHz band.

You must set up the appropriate country code to the product.

Example;

Case1:

When you use the “P” destination products and bring move to Russia or Israel,
If you did not setup change country code and use in Russia and Israel,
You will be on the illegal Radio Law in Russia and Israel.

Case2;

When you use “C” or “D” destination product bring move to Japan or Taiwan,
If you did not setup change country code and use in Japan and Taiwan,
You will be on the illegal Radio Law in Japan and Taiwan.

Service Parts information:

The default country code is set on “Processing Circuit Board(PRC board)”.
You must make sure and set up the “[Country Code](#)” when you replace the processing circuit pc board.
Otherwise You and your customer should be on the illegal Radio Law and

IT HAS POSSIBILITY TO HAVE A RISK OF PUNISHMENT FROM EACH COUNTRY GOVERNMENT.

If you did not make sure country code and no setup code and face any trouble,
We does not have any responsibility.

For setting up the [Country Code](#),

Please ask the procedure of changing country code to your distributor or our sales.

It is no described the procedure of changing [Country Code](#) on this Service Manual

If you have any trouble of unclear procedure for update country code,
Please contact our sales department.

PRC Board Default Value of Country Code

The PRC board is already set default Country Code by the representative destination.
To confirm the default country code, Please refer to the "[How to read PRC Board part number and Default value of Country Code](#)" section.

IMPOTANT!!

Make sure and Setup Country Code

You have to make sure country code for using or replacing "Processing Circuit PC Board".

It means that you have to make sure country code between using Processing Circuit PC board(PRC Board) and your customer's country code.

When it is not match PRC board default country code and customer's country, you have to setup Country Code.

Case3;

When you repair the "P" destination products and replace "P" destination PRC Board and the customer live in UK, It is no necessary to setup Country Code

Because "P" destination PRC board already setup "EU" country code.



Match Country code
NO NECESSARY TO SETUP COUNTRY CODE

Case4;

When you repair the "P" destination products and replace "P" destination PRC board and the customer live in Russia, It is necessary to setup Country Code

Because "P" destination PRC Board already setup "EU" country code.

However, the customer's country code is "RU". It means no match PRC Board code and Customer's code.



No Match Country code
NECESSARY TO SETUP COUNTRY CODE

Case5;

When you repair the "C" destination products and replace "C" destination PRC board and the customer live in US, it is no necessary to setup Country Code

Because "C" destination PRC board already setup "US" country code.



Match Country code
NO NECESSARY TO SETUP COUNTRY CODE

Case6;

When you repair the "C" destination product and replace "C" destination PRC board and the customer live in Taiwan, It is necessary to setup Country Code.

Because "C" destination PRC Board already setup "US" country code as default.

However, the customer's country code is "TW". It means no match PRC Board code and the customer's country code



No Match Country code
NECESSARY TO SETUP COUNTRY CODE

Region	Country	Code
America	USA	US
	Canada	US
	Mexico	US
	Brazil	US
	Chile	CL
	Guatemala	US
	Puerto Rico	US
	Trinidad	TT
	Dominican Rep	US
	Argentina	AR
	Ecuador	US
	Paraguay	PY
	Colombia	US
	Guam	US
	Panama	US
	Costa Rica	US
	Uruguay	UY
Peru	PE	

Region	Country	Code
Asia / Oceania	Japan	JP
	China	CN
	Hong Kong	EU
	Korea	KR
	Taiwan	TW
	Singapore	SG
	Malaysia	MY
	Philippines	EU
	Vietnam	EU
	Indonesia	ID
	Sri Lanka	EU
	Australia	AU
	New Zealand	AU
	Thailand	EU
	India	IN
	Pakistan	PK

Region	Country	Code
Middle East	UAE	EU
	Bahrain	BH
	Kuwait	KW
	Oman	EU
	Qatar	QA
	Lebanon	EU
	Jordan	JO
	Saudi Arabia	EU

Region	Country	Code
Europe / Africa	Germany	EU
	UK	EU
	France	EU
	Netherlands	EU
	Italy	EU
	Switzerland	EU
	Denmark	EU
	Sweden	EU
	Austria	EU
	Belgium	EU
	Spain	EU
	Norway	EU
	Finland	EU
	Czech	EU
	Israel	IL
	Ukraine	EU
	Hungary	EU
	Slovakia	EU
	Luxembourg	EU
	Turkey	EU
Portugal	EU	
Malta	EU	
Latvia	EU	
Poland	EU	

Region	Country	Code
Europe / Africa	Cyprus	EU
	Estonia	EU
	Slovenia	EU
	Bulgaria	EU
	Greece	EU
	Romania	EU
	Lithuania	EU
	Serbia	EU
	Croatia	EU
	Ireland	EU
	Macedonia	EU
	Moldova	EU
	Russia	RU
	Andorra	EU
	Armenia	EU
	Azerbaijan	EU
	Belarus	EU
	Bosnia and Herzegovina	EU
	Northern Cyprus(Turkey)	EU
	Georgia	EU
	Iceland	EU
	Kazakhstan	EU

Region	Country	Code
Europe / Africa	Liechtenstein	EU
	Monaco	EU
	Montenegro	EU
	San Marino	EU
	Vatican City	EU
	Kosovo	EU
	Kaliningrad(Russia)	RU
	Gibraltar(UK)	EU
	Canary Islands(Spain)	EU
	Ceuta	EU
	Melilla	EU
	Morocco	MA
	Algeria	EU
	Tunisia	TN
	Egypt	EG
	Mauritius	US
South Africa	EU	

How to read PRC Board part number and Default value of Country Code

WiFi 5GHz Setting

1B5142034-1A555MDC

Board No.

Suffix No.

Model Number Last 3 Digit	
555	TX-NR555
656	TX-NR656
757	TX-NR757
695	HT-R695
610	TX-RZ610
710	TX-RZ710
810	TX-RZ810

Destination		
PRC Board Default setting Country Code		
Dst	Code	Main Country
C	US	North America
D	US	United State
S	US	Brazil
P	EU	Europe
B	EU	United Kingdom
Q	EU	Hong Kong
T	EU	Thai
L	RU	Russia
A	AU	Australia / New Zealand
R	CN	China
F	TW	Taiwan
K	KR	Korea
J	JP	Japan

How to check Firmware Version & Preparation of Update

Step1 : [DIMMER] + [ON/STANDBY] x 2

Main Firmware Version will appear on the main unit's display.

Step2 : [TONE +1] (Rotate "TONE" knob right 1 click)

NET Firmware Version will appear on the main unit's display.

Step3 : [TONE +2] (Rotate "TONE" knob right 2 click)

DSP Firmware Version will appear on the main unit's display.

Step4 : [TONE +3] (Rotate "TONE" knob right 3 click)

Video Firmware Version will appear on the main unit's display.

Step3 : [TONE +4] (Rotate "TONE" knob right 4 click)

OSD Firmware Version will appear on the main unit's display.

Step4 : [TONE +5 over] (Rotate "TONE" knob right 5 click over)

Return to Display Main Firmware Version (Return Step1)

When It is rotated left (-) TONE knob, It is appeared before step.

[Preparation of Update]

1. Connect the USB storage device to your PC. If there is any data in the USB storage device, remove it.
2. Download the firmware file (package file) from the Onkyo FTP-server. However European service partners should download the firmware file (package file) from the ExtraNet.

Onkyo FTP-server: <ftp://manex.onkyo.co.jp/>

ID and Password are those we informed when changed.

Filename is as follows: ONKAVR0001*****.zip

Unzip the downloaded file. A following file is created.

ONKAVR0001*****.of0

ONKAVR0001*****.of1

ONKAVR0001*****.of2

ONKAVR0001*****.of3

ONKAVR0001*****.of4

3. Copy it to the USB storage device. Be careful not to copy the zip file.
4. Remove the USB storage device from your PC.

How to Update (service mode) 1/2

Firmware

Overwriting is also possible.

1. Connect the USB storage to the USB port on the unit.



2. Turn on the unit. It takes some time to start after you switch on the unit.
Press: [DIMMER] + [ON/STANDBY] x 2
3. Press [RETURN] button, Then it is displayed as below



If you need each module of the firmware update, you can select the module by pressing PRESET < and > button.

If you need change source NET or USB, you can select the source by pressing TUNING UP and Down key

It should be updated firmware by selecting USB -> ALL normally.

Please Do NOT choose T-SRV (it is test server)

- USB -> ALL: ALL firmware update (default)
- USB -> DSP1: DSP firmware update
- USB -> OSD: OSD firmware update
- USB -> VMPU: VMPU firmware update
- USB -> NET: NET firmware update
- USB -> MMPU: Main MPU firmware update
- USB -> WORK: Compare between AVR and USB, Only update new version firmware

- NET -> ALL: ALL firmware update (default)
- NET -> DSP1: DSP firmware update
- NET -> OSD: OSD firmware update
- NET -> VMPU: VMPU firmware update
- NET -> NET: NET firmware update
- NET -> MMPU: Main MPU firmware update
- NET -> WORK: Compare between AVR and MMC,
Only update new version firmware by network

The default setting is " ALL "

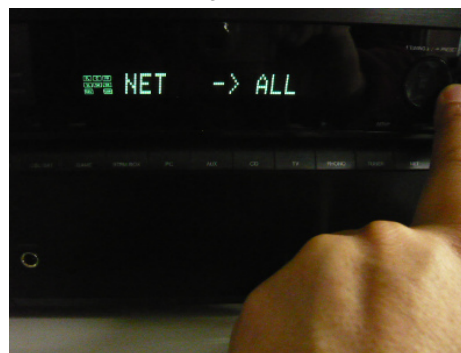

CAUTION: When you will update each module firmware, you have to keep combination of firmware.

How to Update (service mode) 2/2

Firmware

4. Press [ENTER] button. Start update firmware.



5. Wait until update is completed. When the update ends, "Completed!" is displayed. When "Completed!" message appeared, you can power off by pressing "ON/STANDBY" button. (If you leave it, it automatically turns standby mode.)



6. Press [ON/STANDBY] button, and the unit turns on.

7. Check the new FW version number.

<Note>

If the procedure might not be successful, please select "USB -> ALL".

How to Adjust Idling

The Idling current adjustment is unnecessary.
 If did the repair of amplifier circuit, please confirm the idling current after 4 ~ 6 minutes heat running. If the measured value are under 1mV or over 21mV , turn off the power of the AVR and check the parts of defect channel again.

Chanel	Measurement Points	Permissible Range
FL	P6021	1mV ~ 21mV
FR	P6022	
C	P6023	
SL	P6025	
SR	P6026	
SBL	P6027	
SBR	P6028	

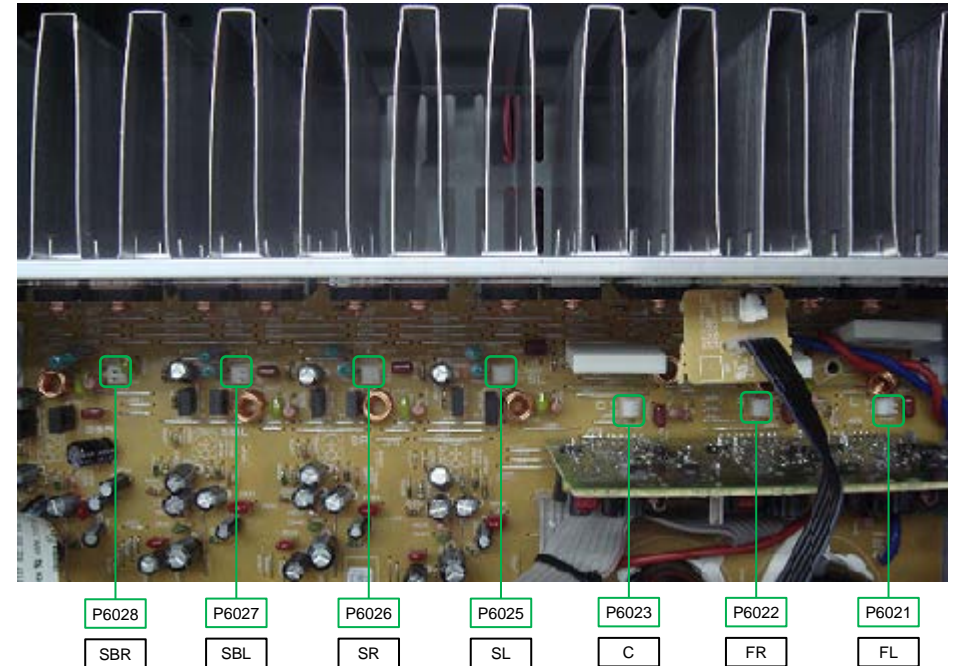

*Heat sink is different by each model.

Connection

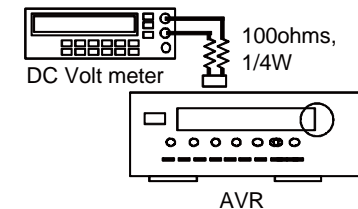

TX-NR555/TX-NR656/TX-RZ610/HT-R695
 TX-NR757/TX-RZ710/TX-RZ810
 DRX-2/DRX-3/DRX-4/DRX-5

No Sound

Hookup and Setting

■ No sound from connected player

- Chose input selector which is assigned to connected input terminal ?
- Isn't muting on ?

■ No sound from connected TV

- Chose wrong input selector ?
- Connect to this model's HDMI OUT terminal from TV by HDMI cable ?
- When TV supports ARC function, connect to his model's HDMI OUT terminal from TV's HDMI input terminal for ARC function ?
- When TV doesn't support ARC function, connect TV to this model with optical cable etc. ?
- Isn't muting on ?

■ No sound from some connected loudspeaker(s)

- No sound loudspeaker(s) config is enabled ?

■ No sound from all connected TV or Blu-ray player etc.

- After chose loudspeaker volume level setting, test tone is OK ?

■ No problem about above items

- Unplug power cord
After 10 seconds, connect power cord again
- Reset this model

No Picture

Hookup and Setting

■ In general

- Connection cable is bent , twisted or damaged ?
- Input is switched on TV ?

■ No picture from connected player by HDMI input terminal

- Chose input selector which is connected to player ?
- Listening mode is not Pure Audio ?
- Don't use HDMI-DVI adaptor. From personal computer ?

■ No picture from connected player by component video terminal

- Output to TV connected to component video out terminal from player's picture connected to the composite video input terminals ?

■ No problem about above items

- Unplug power cord
After 10 seconds, connect power cord again
- Reset this model

No Power

Hookup and Setting

■ In general

Doesn't be connection cable bent, be it twisted and be it damaged?

■ There is time when indication on the front panel doesn't just light up.

Please check the connecting cord of a DISPLAY PCB.

■ No problem about above items

Unplug power cord

After 10 seconds, connect power cord again

Reset this model

No Sound (HDMI in)

Trouble Shoot

Here the trouble shoot which focuses on the hardware troubles regarding PCB assembly is explained.
 Of course, with actual repair there are also troubles due to damaged Power Transformer, Wiring, soldering etc. in addition to PCB assembly.

Process	Check Point	Damaged PCB
1	J6504(BATRM-2023) ● +24V	BAAF-1979
2	P8002A(BADG-1985) 5 -15V 7 +15V	BAAF-1979
3	P2802B(BAPRC-2034) 1 +12V ~ +15V	BATRM-2023
4	P8003A(BADG-1985) 28 +3.3V	BAPRC-2034
5	P8002A(BADG-1985) 29 Signal 30 Signal	BAPRC-2034
6	Q1501(BADG-1985) 1 Signal	BADG-1985
7	● J4606(BAAF-1979)	BAAF-1979
8	Q6001, Q6021(BAAF-1979) ● Base	BACLA-1988
9	P2800B(BAPRC-2034) 10 +3V (HIGH)	BAAF-1979
10	● P6021(BAAF-1979) The amplified beautiful wave.	BAAF-1979
11		BATRM-2023

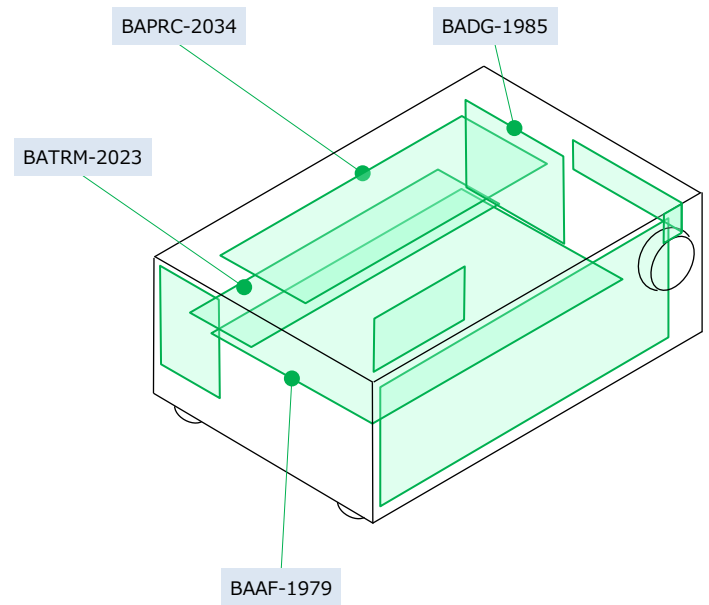

No Sound (Opt in)

Trouble Shoot

Here the trouble shoot which focuses on the hardware troubles regarding PCB assembly is explained.
Of course, with actual repair there are also troubles due to damaged Power Transformer, Wiring, soldering etc. in addition to PCB assembly.

Process	Check Point	Damaged PCB
1	J6504(BATRM-2023) ● +24V	BAAF-1979
2	P8002A(BADG-1985) 5 -15V 7 +15V	BAAF-1979
3	P2802B(BAPRC-2034) 1 +12V ~ +15V	BATRM-2023
4	P8003A(BADG-1985) 28 +3.3V	BAPRC-2034
5	P8003A(BADG-1985) 25 Signal	BADG-1985
6	P8002A(BADG-1985) 29 Signal 30 Signal	BAPRC-2034
7	Q1501(BADG-1985) 1 Signal	BADG-1985
8	● J4606(BAAF-1979)	BAAF-1979
9	Q6001, Q6021(BAAF-1979) ● Base	BACLA-1988
10	P2800B(BAPRC-2034) 10 +3V (HIGH)	BAAF-1979
11	● P6021(BAAF-1979) The amplified beautiful wave.	BAAF-1979
12		BATRM-2023

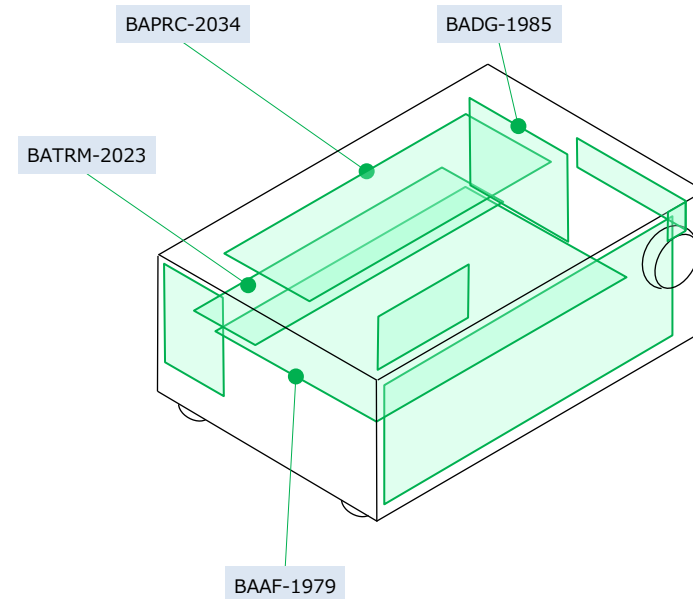

No Sound (Analog in)

Trouble Shoot

Here the trouble shoot which focuses on the hardware troubles regarding PCB assembly is explained.
 Of course, with actual repair there are also troubles due to damaged Power Transformer, Wiring, soldering etc. in addition to PCB assembly.

Process	Check Point	Damaged PCB
1	J6504(BATRM-2023) ● +24V	BAAF-1979
2	P8002A(BADG-1985) ⑤ -15V ⑦ +15V	BAAF-1979
3	● J4606(BAAF-1979)	BAAF-1979
4	Q6001, Q6021(BAAF-1979) ● Base	BACLA-1988
5	P2800B(BAPRC-2034) ⑩ +3V (HIGH)	BAAF-1979
6	● P6021(BAAF-1979) The amplified beautiful wave.	BAAF-1979
7		BATRM-2023

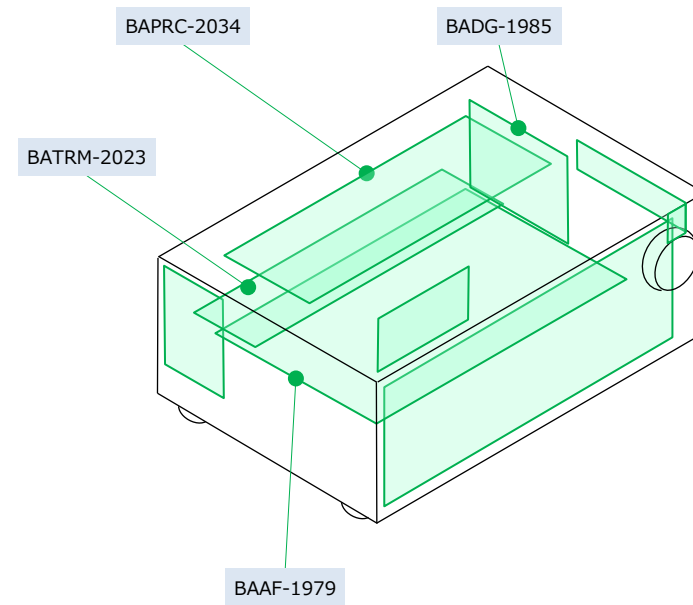

No Picture (HDMI in/ out)

Trouble Shoot

Here the trouble shoot which focuses on the hardware troubles regarding PCB assembly is explained.
Of course, with actual repair there are also troubles due to damaged Power Transformer, Wiring, soldering etc. in addition to PCB assembly.

Process	Check Point	Damaged PCB
1	P2802B(BAPRC-2034) 1 +12V ~ +15V	BATRM-2023
2		BAPRC-2034

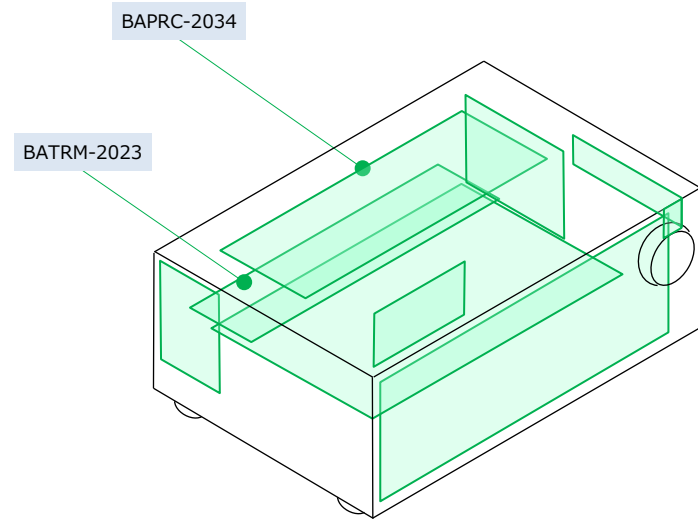

No Picture (Component in/ HDMI out)

Trouble Shoot

Here the trouble shoot which focuses on the hardware troubles regarding PCB assembly is explained.
 Of course, with actual repair there are also troubles due to damaged Power Transformer, Wiring, soldering etc. in addition to PCB assembly.

Process	Check Point	Damaged PCB
1	P2802B(BAPRC-2034) ① +12V ~ +15V	BATRM-2023
2	P2800B(BAPRC-2034) ⑱ +5V	BAPRC-2034
3	P2800B(BAPRC-2034) ⑲ ⑳ ㉑	BATRM-2023
4		BAPRC-2034

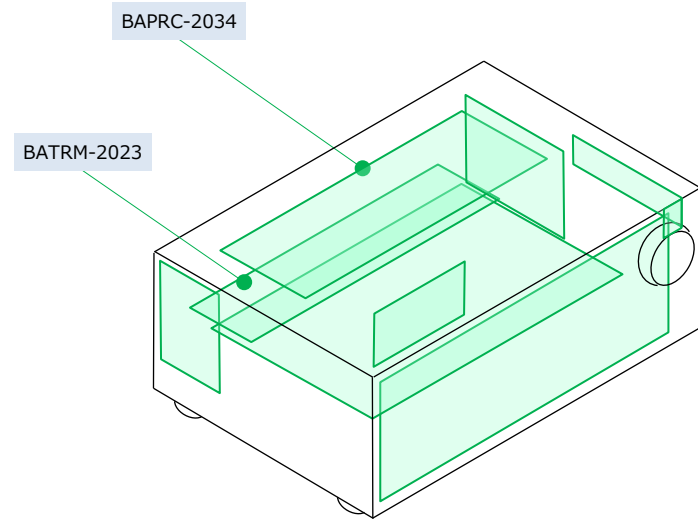

No Picture (Composite in/ HDMI out)

Trouble Shoot

Here the trouble shoot which focuses on the hardware troubles regarding PCB assembly is explained.
Of course, with actual repair there are also troubles due to damaged Power Transformer, Wiring, soldering etc. in addition to PCB assembly.

Process	Check Point	Damaged PCB
1	P2802B(BAPRC-2034) ① +12V ~ +15V	BATRM-2023
2	P2800B(BAPRC-2034) ⑰ +5V	BAPRC-2034
3	P2800B(BAPRC-2034) ⑲	BATRM-2023
4		BAPRC-2034

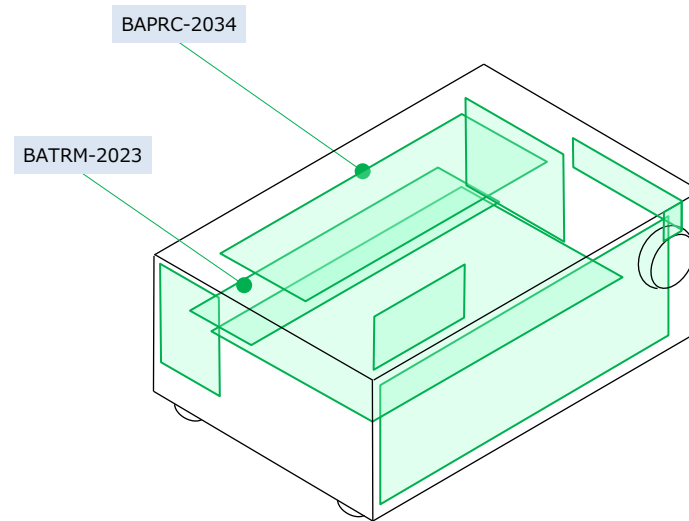

No Power

Trouble Shoot

Here the trouble shoot which focuses on the hardware troubles regarding PCB assembly is explained.
Of course, with actual repair there are also troubles due to damaged Power Transformer, Wiring, soldering etc. in addition to PCB assembly.

Process	Check Point	Damaged PCB
1	C9001(BAPS-1984) ● AC100V~240V	BAPS-1984
2	● F9002(BAPS-1984)	BAAF-1979 BACLA-1988
3	● F6901, F6902(BAAF-1979)	BAAF-1979 BACLA-1988
4	ANY PARTS(BAAF-1979)	BAAF-1979 BACLA-1988
5	FFC P7001(BAPRC-2034)	P7001(FFC)
6	P2802B(BAPRC-2034) ① +12V ~ +15V	BAPS-1984
7	P2800B(BAPRC-2034) ⑤ +3V (HIGH)	BAPRC-2034
8	P7001A(BAPRC-2034) ⑰ +5V	BAPRC-2034
9	RL9001(BAPS-1984)	BAPS-1984
10	P9002(BAPS-1984) ● AC100V~240V	BATRM-2023 BAPRC-2034 P2800(FFC)
11	FFC P7001(BADIS-1983)	P7001(FFC)
12		BADIS-1983

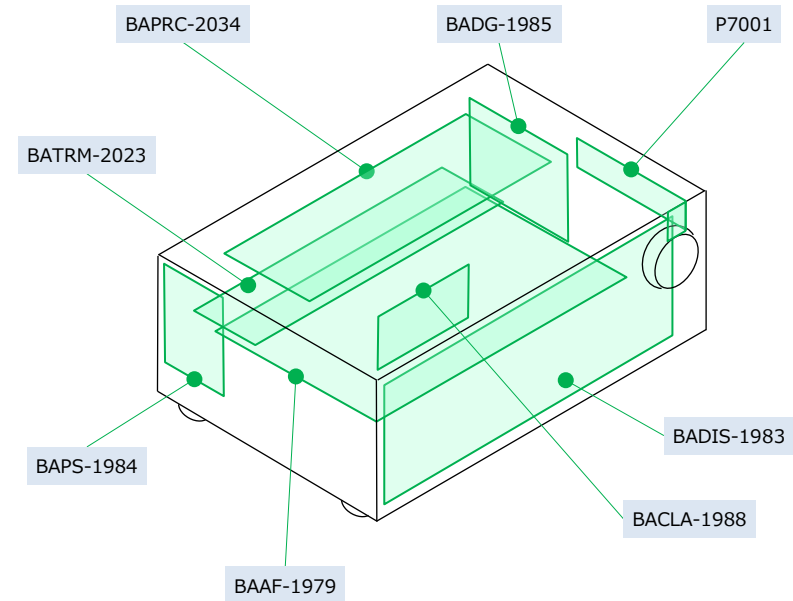

ANY PARTS on BAAF-1979

- Check damage parts
- Normal(OK) or Damage (No good)
- Check the damage in the red framework part as shown with visual inspection.
- e.g. Broken, Burnout, Discoloration, etc.

1. When being not turned on with remote control unit only, BADIS-1983 is abnormal.
2. When being not turned on with button on the main unit only, BADIS-1983 is abnormal.

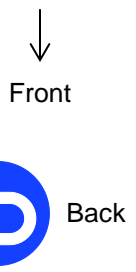
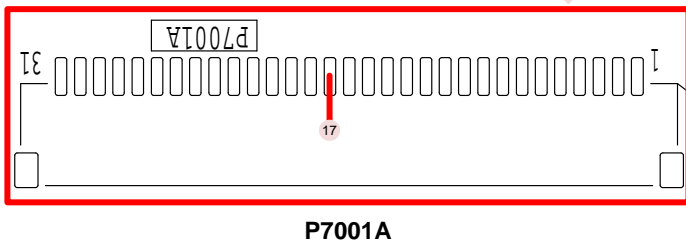
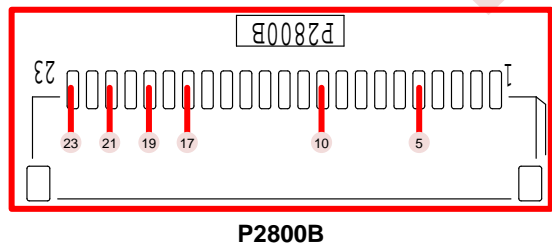
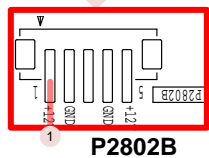
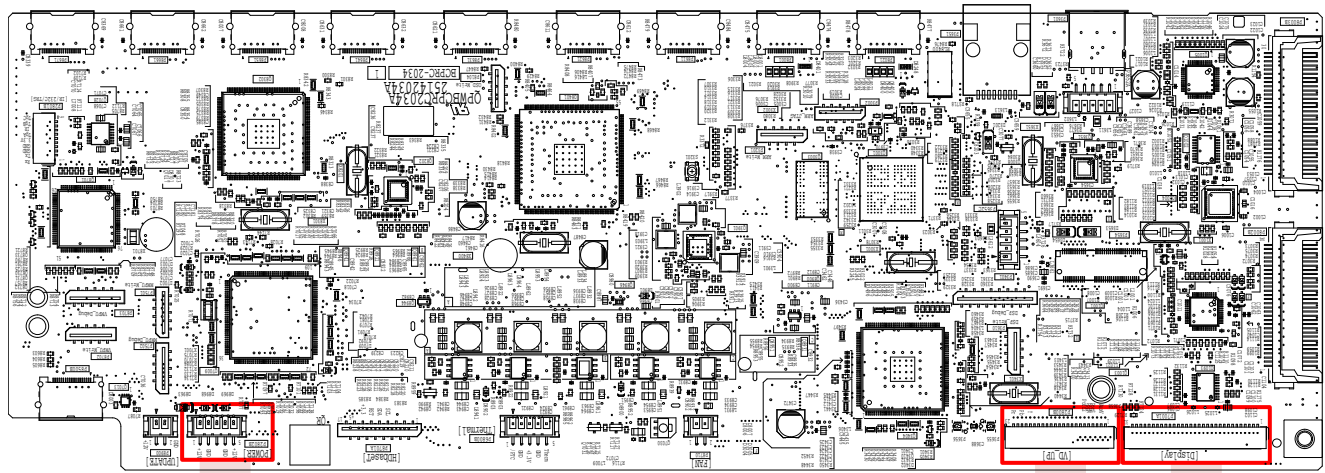

P2802B
Check Voltage
 1 +12V ~ +15V

P2800B
Check Voltage
 5 +3V (HIGH)
 10 +3V (HIGH)
 17 +5V

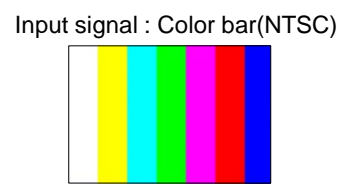
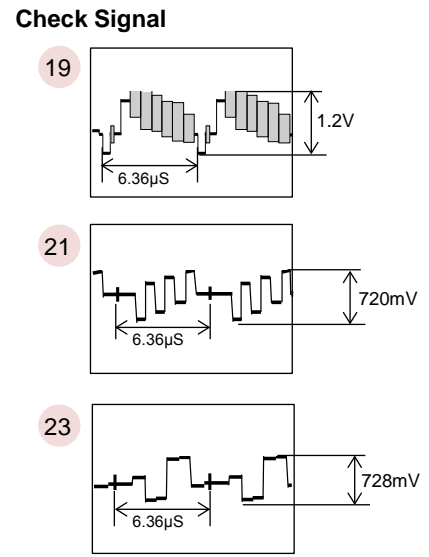

P7001A
 17 +5V

P7001
 Check damage and connection
 How to check
 1.Disconnect the FFC from the socket.
 2.Check the contacts of the FFC.

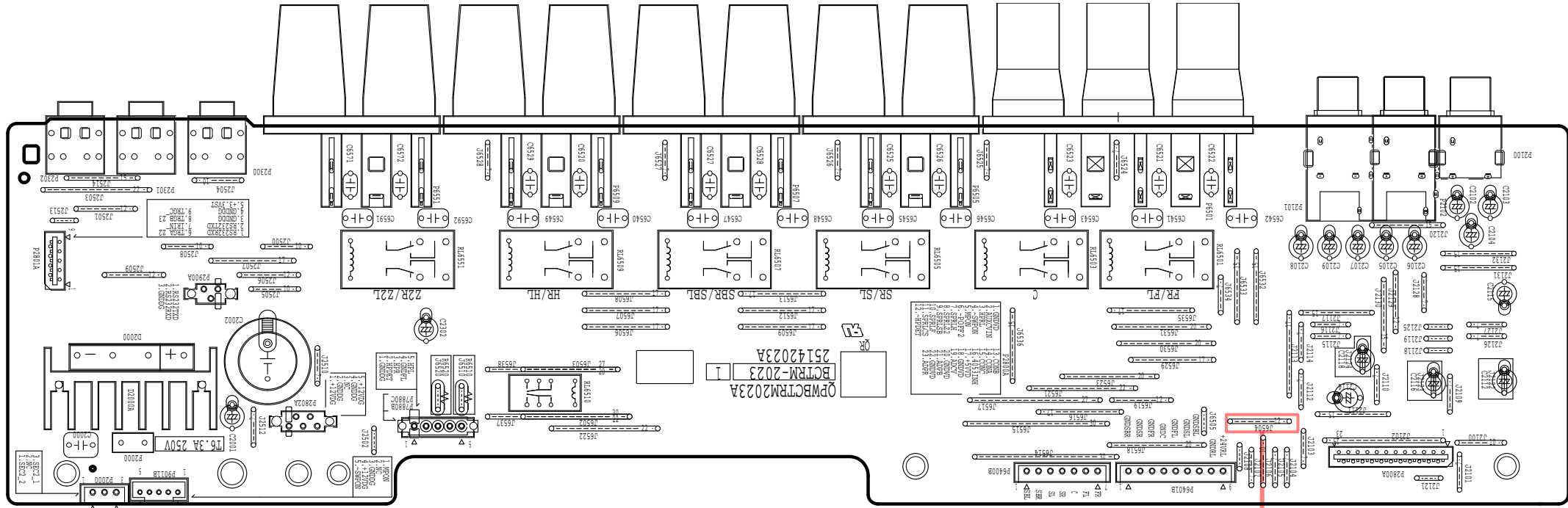

J6504
Check Voltage
+24V

J6504



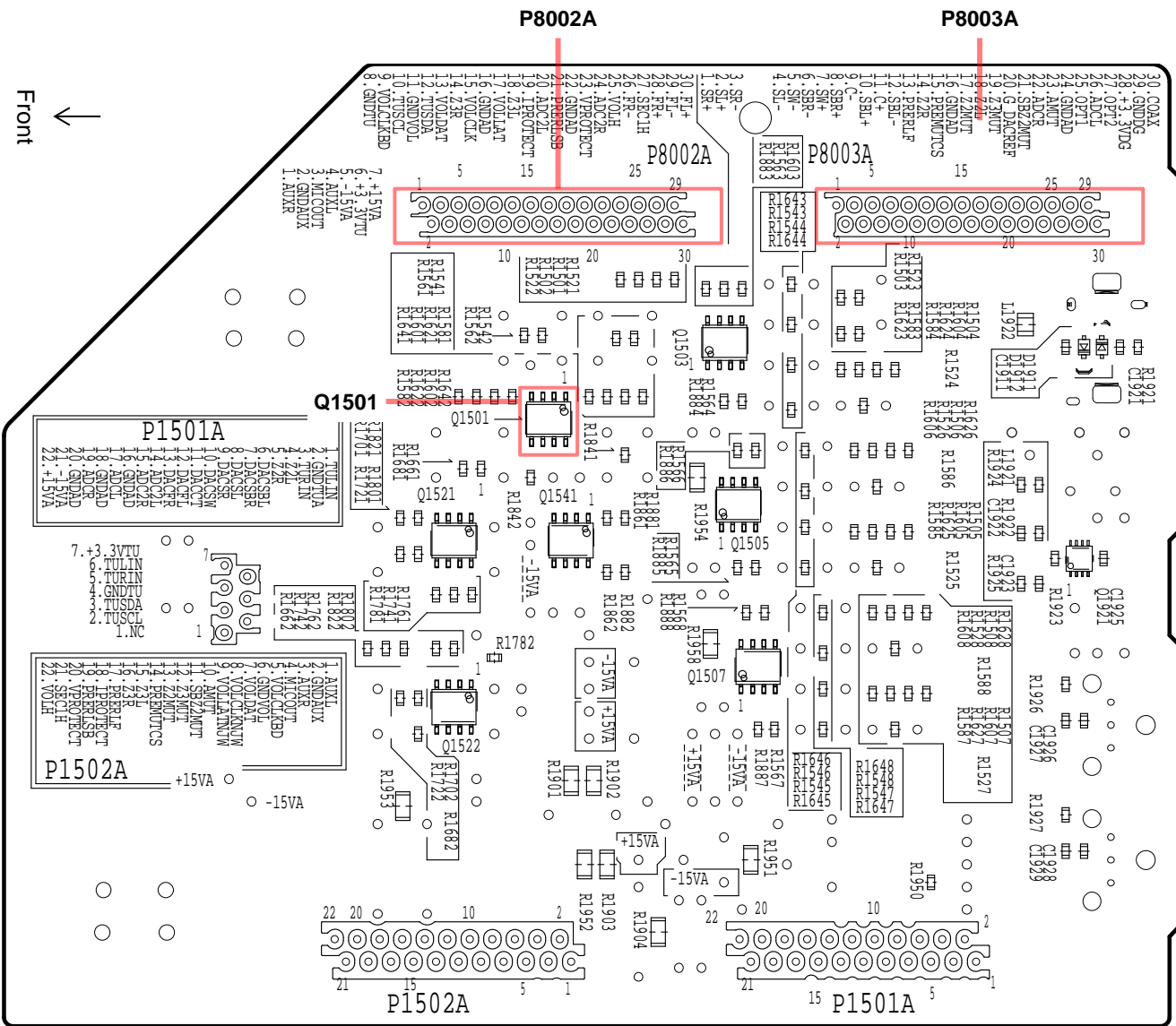

P8002A
Check Voltage
 5 -15V
 7 +15V

Check Signal
 Input terminal : HDMI IN or OPT IN
 Input signal(HDMI/ OPT IN) : Test disc 1kHz 0dB
 Audio format : LPCM, Dolby Digital(Otherwise, CD)
 Speaker Config : 2.0

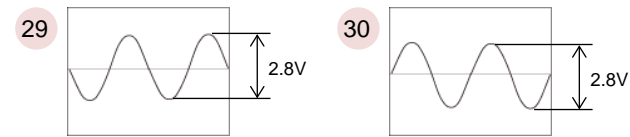

P8003A
check Signal
 Input terminal : HDMI IN or OPT IN
 Input signal(HDMI/ OPT IN) : Test disc 1kHz 0dB
 Audio format : LPCM, Dolby Digital(Otherwise, CD)

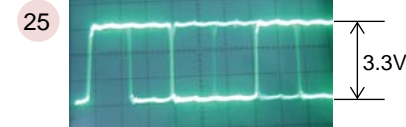

Check Voltage
 28 +3.3V

Q1501
Check Signal
 Input terminal : HDMI IN or OPT IN
 Input signal(HDMI/ OPT IN) : Test disc 1kHz 0dB
 Audio format : LPCM, Dolby Digital(Otherwise, CD)

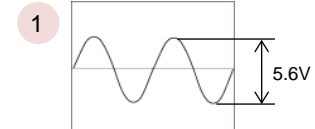

Speaker Config : 2.0



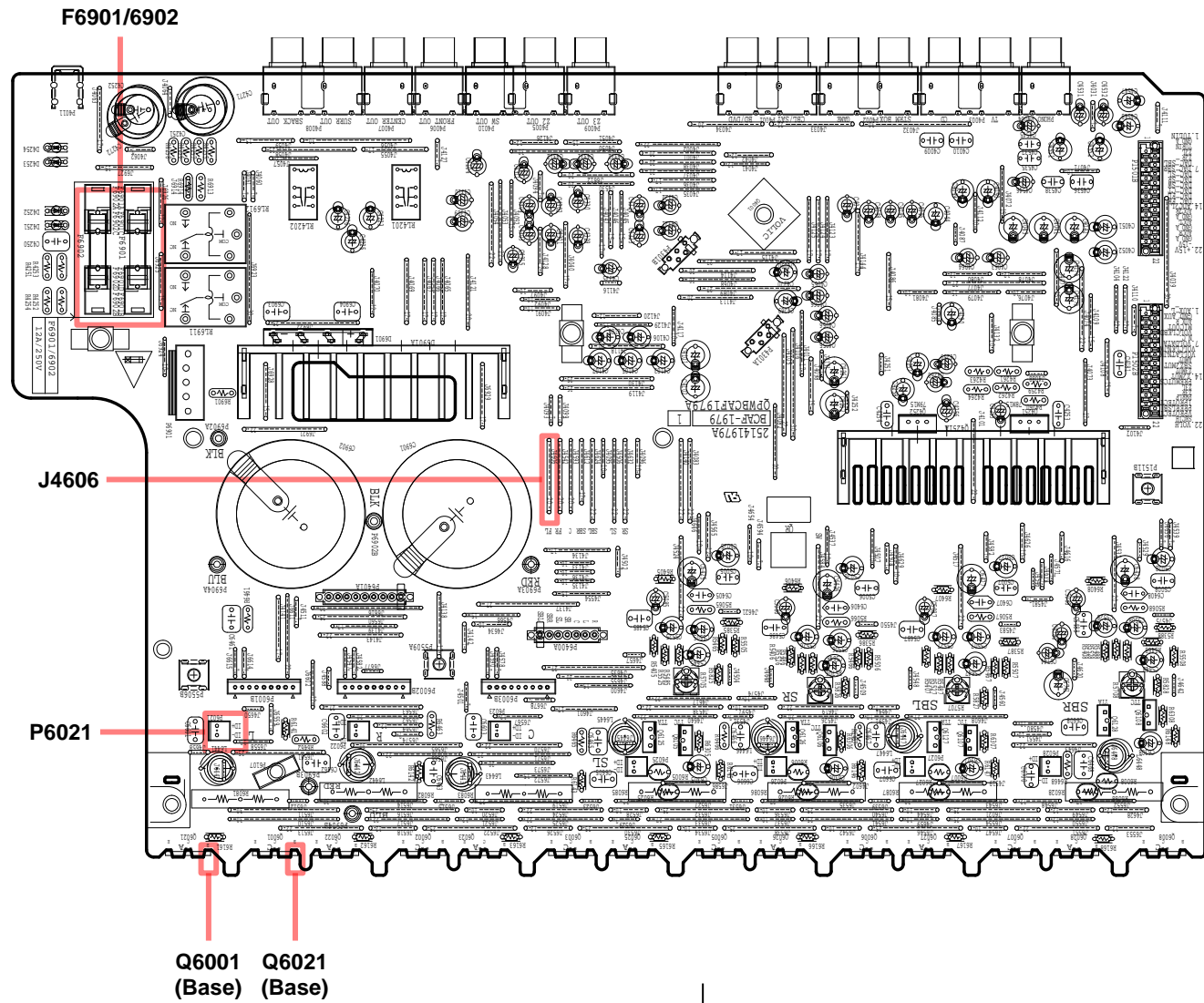

J4606

Check Signal

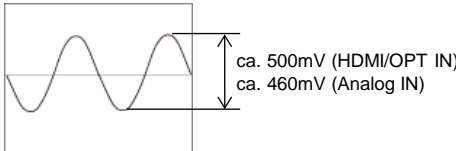

Q6001, Q6021

Check Signal (Base)

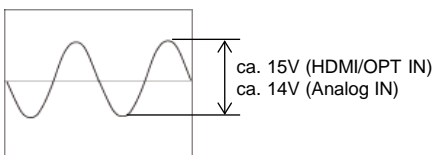

P6021

Check Signal
The amplified beautiful wave.

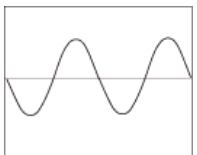

F6901, F6902

Check damage
● Normal (OK) or blown (No good)

J4606, Q6001, Q6021, P6021

Input terminal : HDMI IN or OPT IN or ANALOG IN
 Input signal(HDMI/OPT IN) : Test disc 1kHz 0dB
 Audio format : LPCM, Dolby Digital(Otherwise, CD)
 Input signal(ANALOG IN) : 1kHz 2Vrms
 Master volume : 66

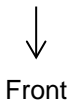

● Each voltage is shown as the reference value.

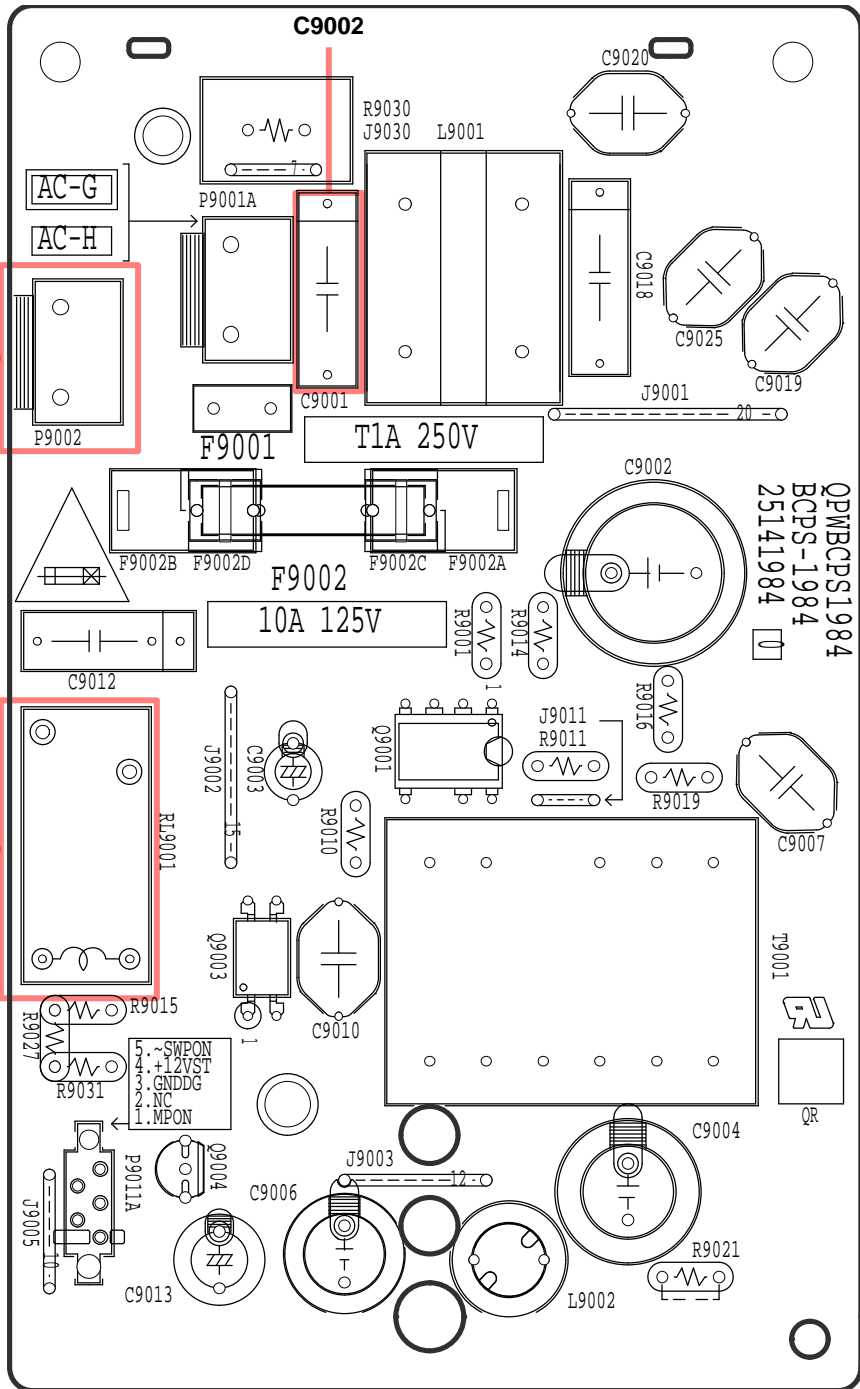

C9002
Check Voltage
 AC100 ~ 240V (Power supply voltage)

RL9001
 Check operation of a relay by sound.
 No sound at all ----> No good

P9002
Check Voltage
 AC100 ~ 240V (Power supply voltage)

Front
 ←

Back

BACLA-1988

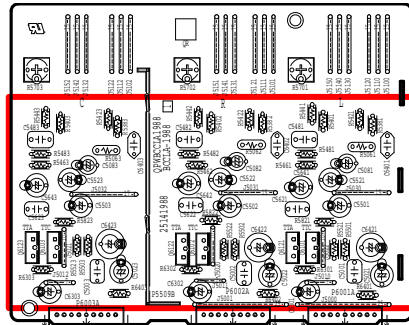

ANY PARTS
Check damage

Normal(OK) or Damage (No good)

Check the damage in the red framework part as shown with visual inspection.

e.g. Broken, Burnout, Discoloration, etc.

BAAF-1979

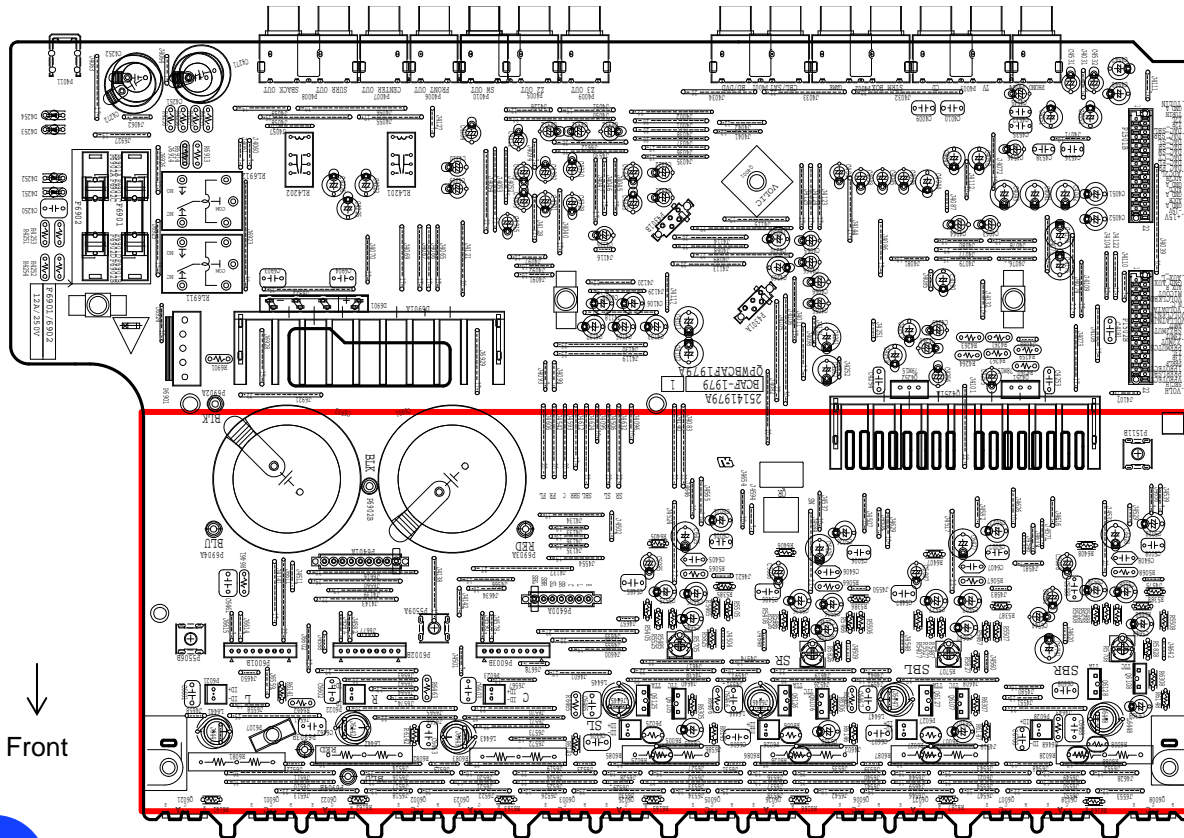

↓
Front

↺
Back

● Each voltage is shown as the reference value.

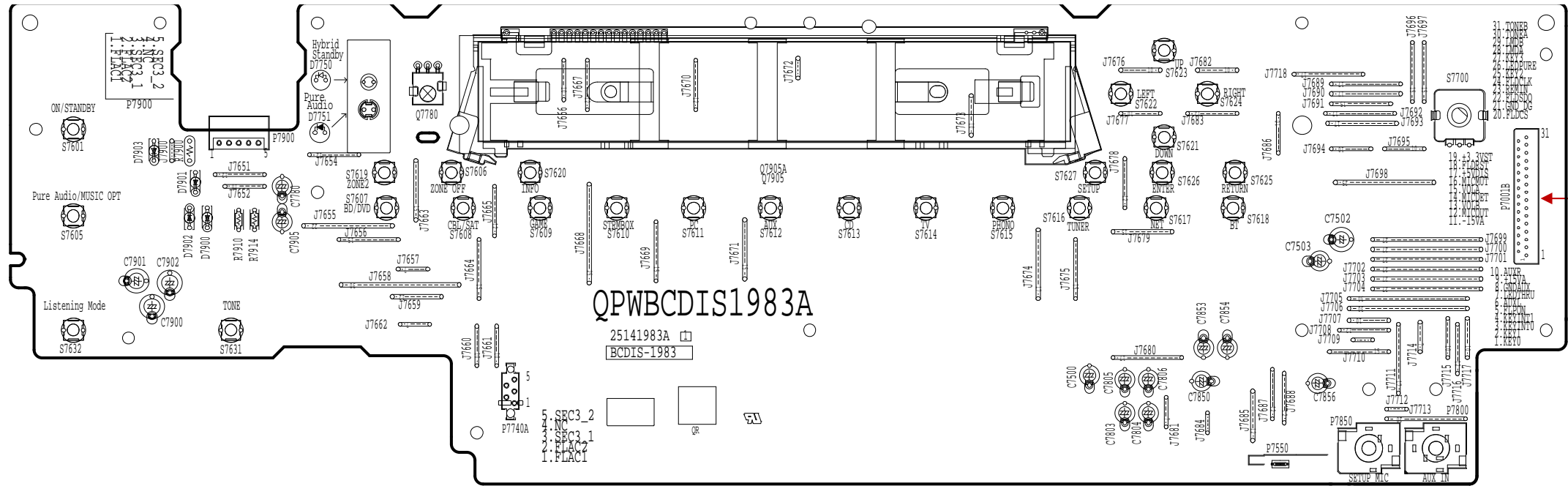

P7001
 ● Check damage and connection
 How to check
 1. Disconnect the FFC from the socket.
 2. Check the contacts of the FFC.

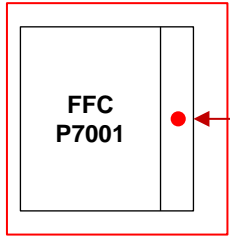

Overview

This model can be disassembled in the order shown below.

Disassembly

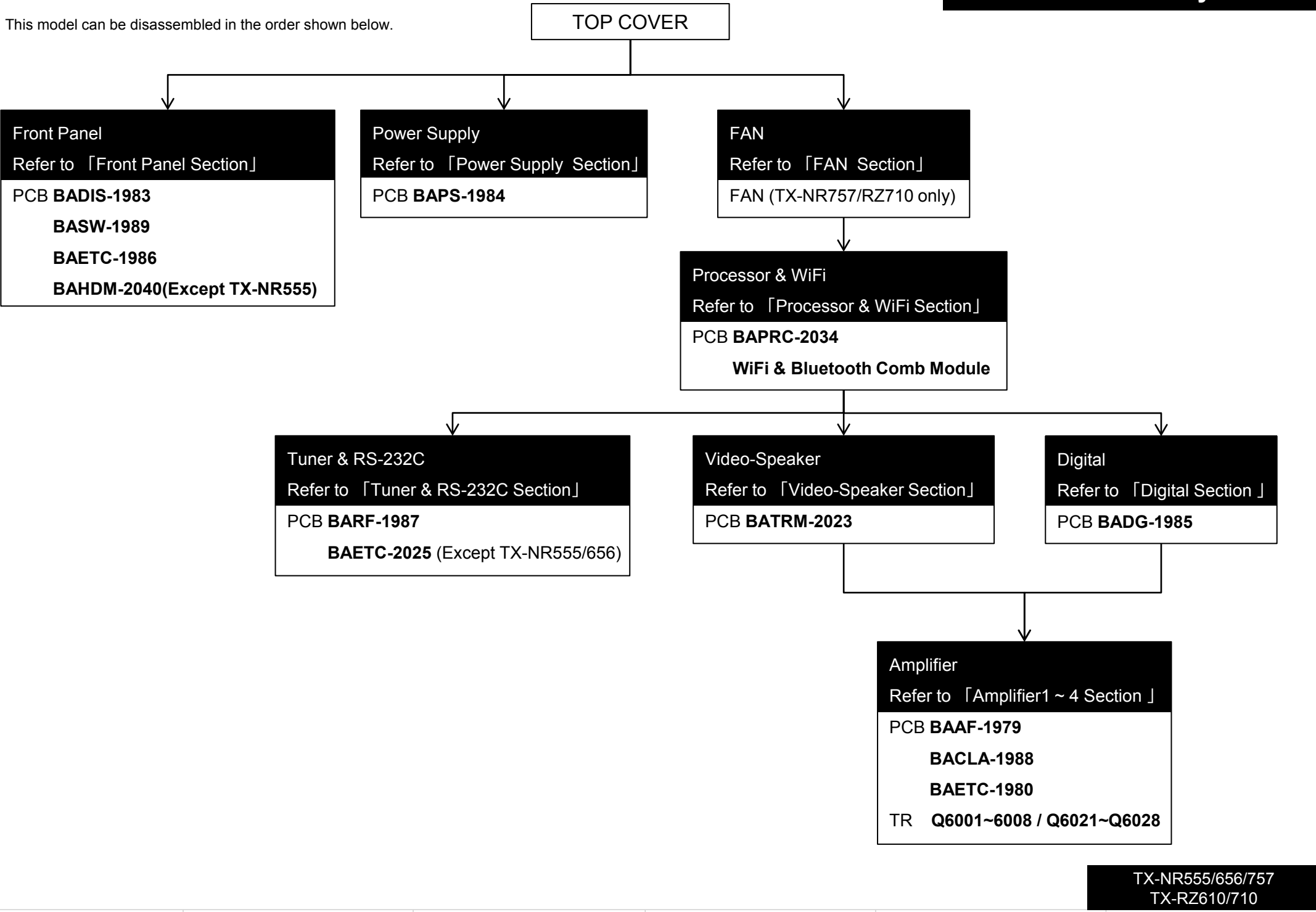

Front Panel Section

This is TX-RZ710. TX-NR555/656//757/RZ610 is same mostly structurally. Please refer to PANEL pages for detailed place by the terminal.

Disassembly

- PCB BADIS-1983
- PCB BASW-1989
- PCB BAETC-1986
- PCB BAHDM-2040(Except TX-NR555)

Except TX-NR555

TX-NR555/656/757
TX-RZ610/710

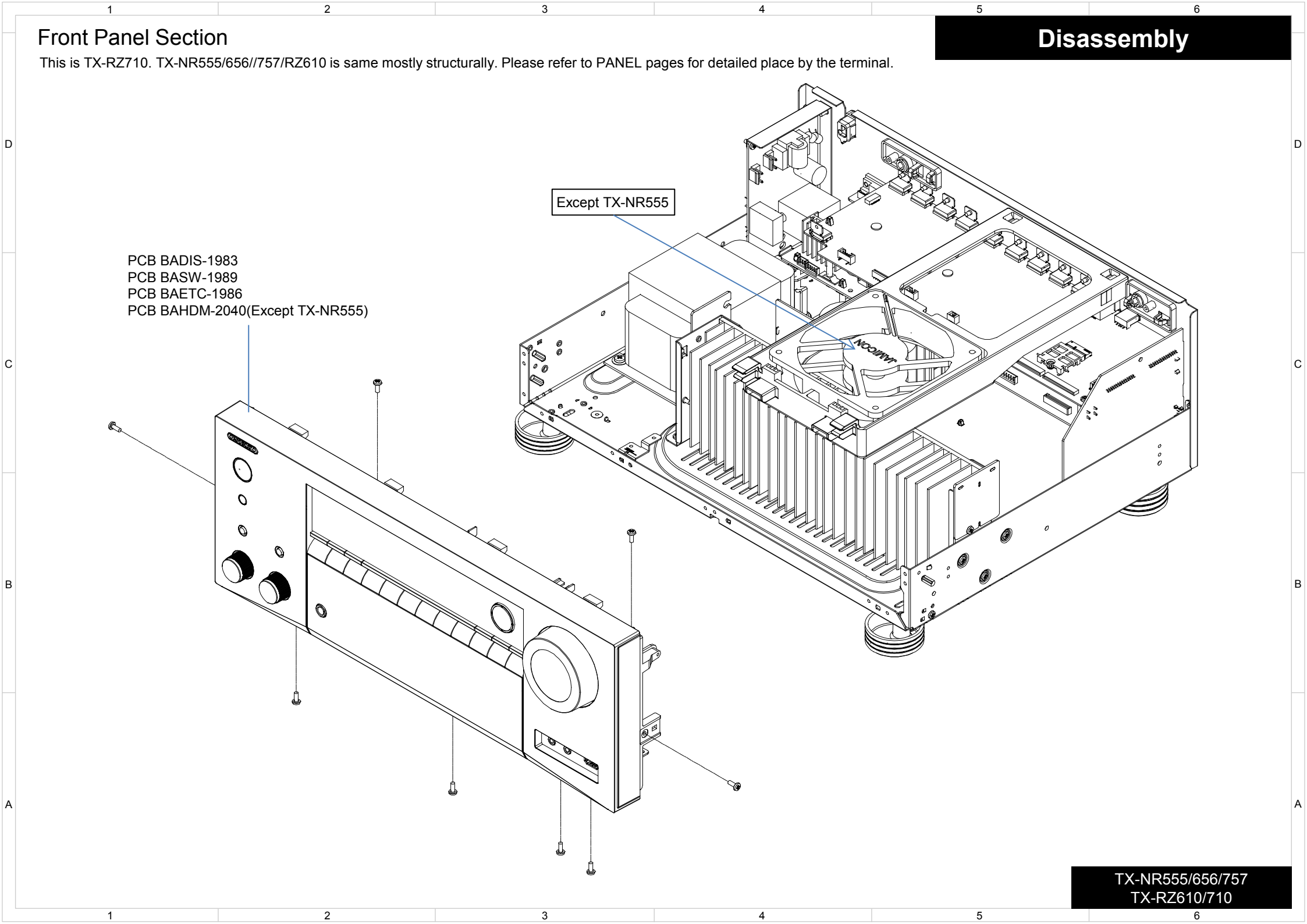

Power Supply Section

This is TX-RZ710. TX-NR555/656//757/RZ610 is same mostly structurally. Please refer to PANEL pages for detailed place by the terminal.

Disassembly

PCB BAPS-1984

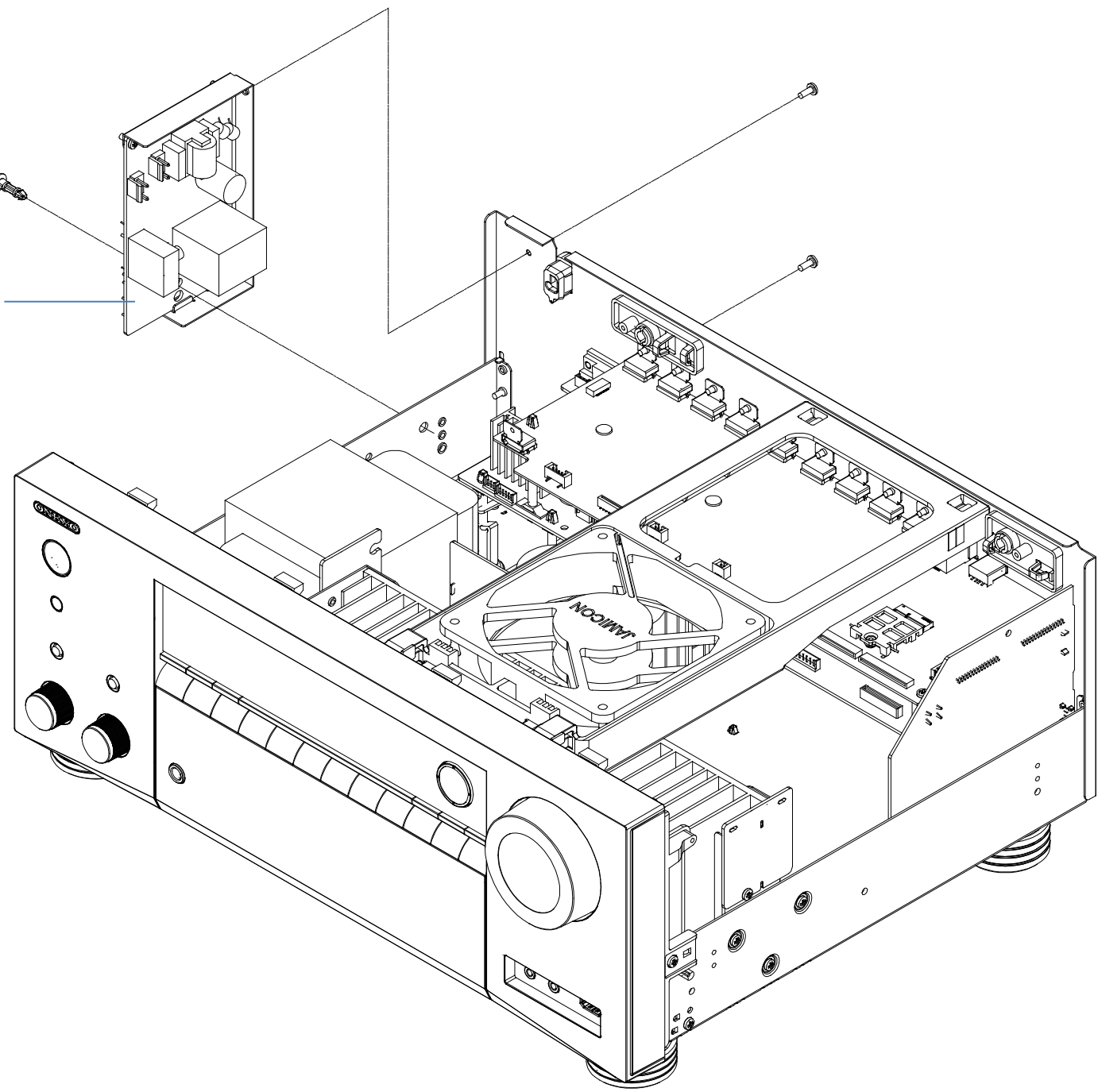

TX-NR555/656/757
TX-RZ610/710

FAN Section

This is TX-RZ710. TX-NR555/656//757/RZ610 is same mostly structurally. Please refer to PANEL pages for detailed place by the terminal.

Disassembly

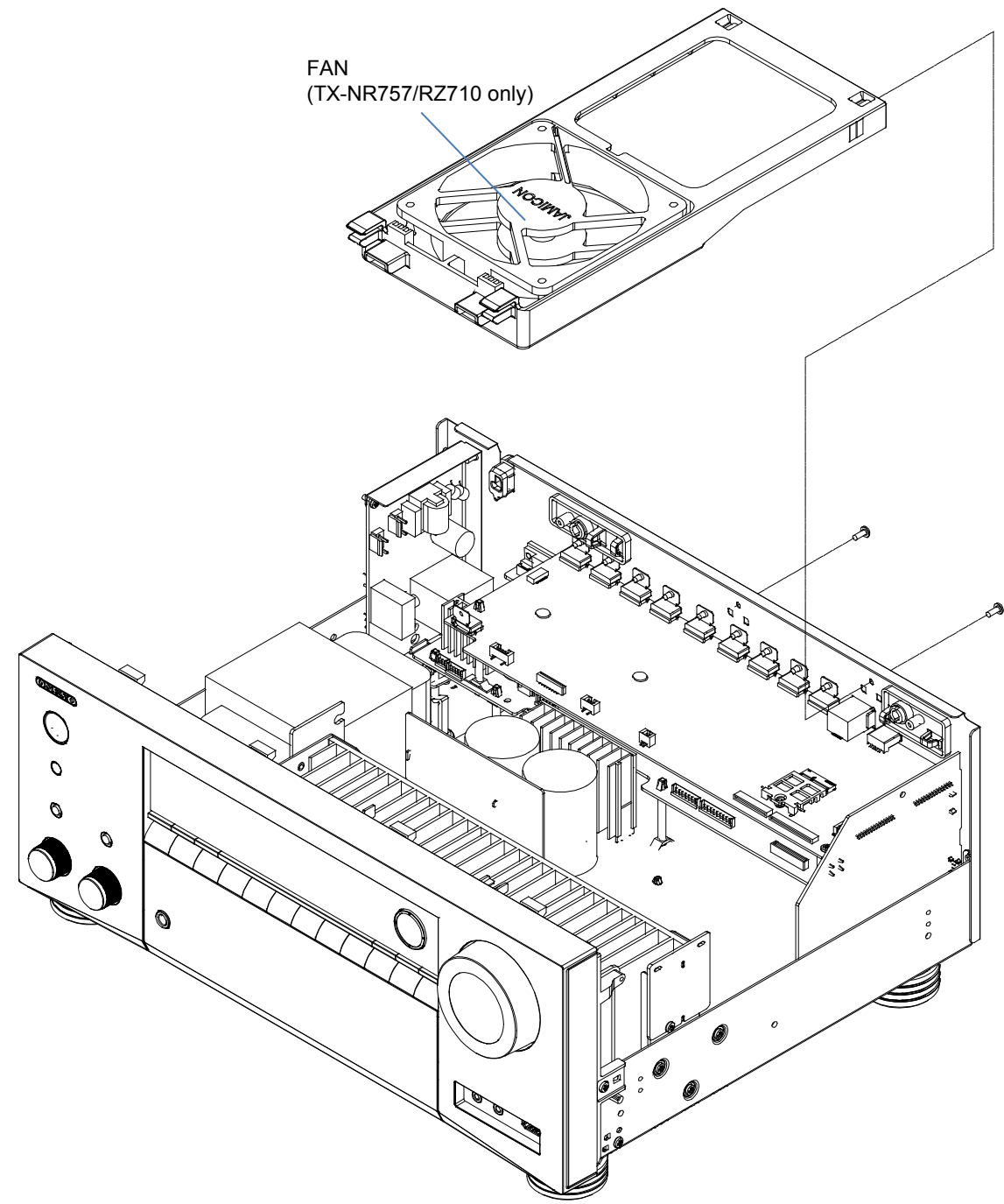

TX-NR555/656/757
TX-RZ610/710

Processor & WiFi Section

This is TX-RZ710. TX-NR555/656//757/RZ610 is same mostly structurally. Please refer to PANEL pages for detailed place by the terminal.

Disassembly

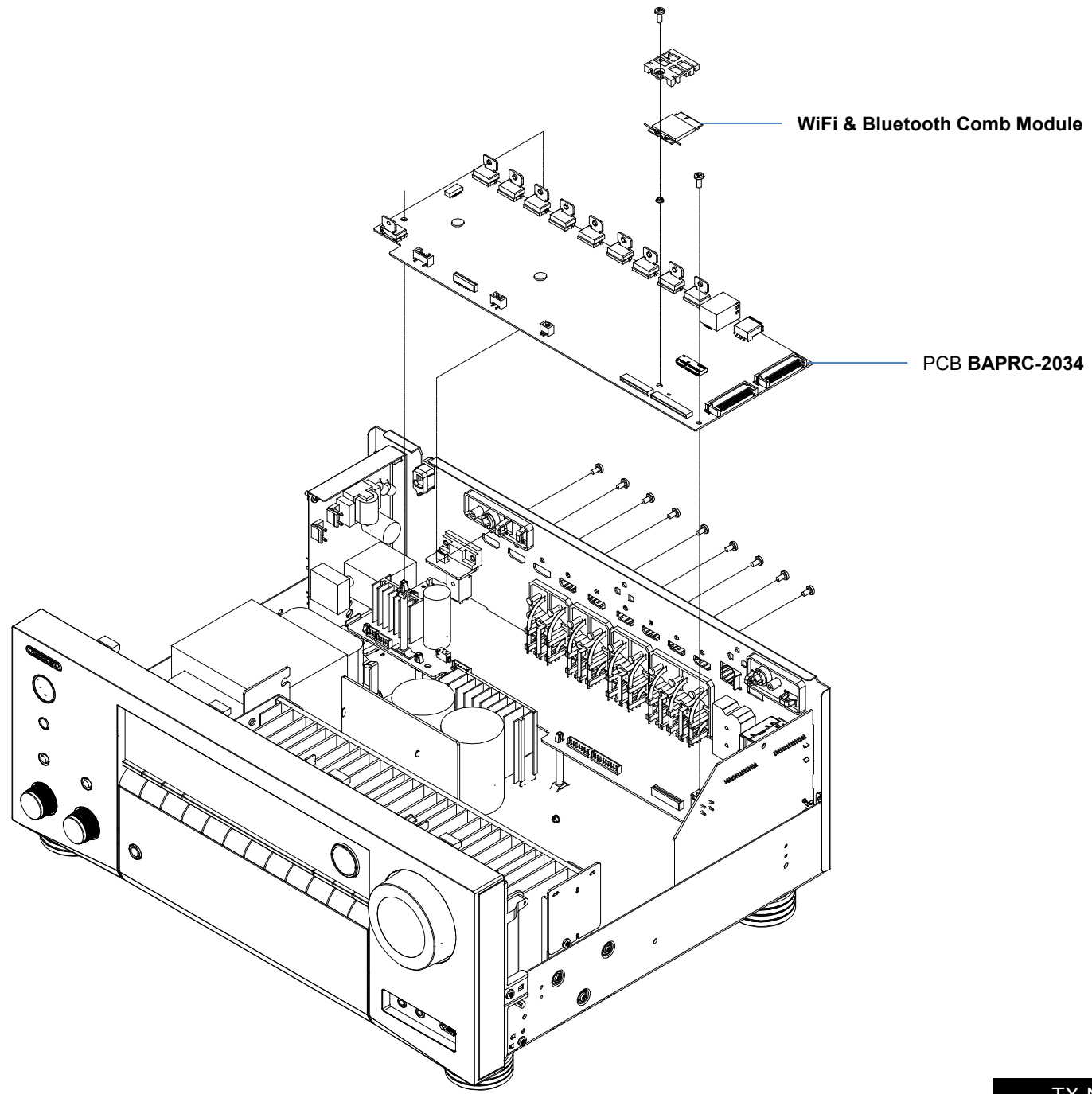

TX-NR555/656/757
TX-RZ610/710

Tuner & RS-232C Section

This is TX-RZ710. TX-NR555/656//757/RZ610 is same mostly structurally. Please refer to PANEL pages for detailed place by the terminal.

Disassembly

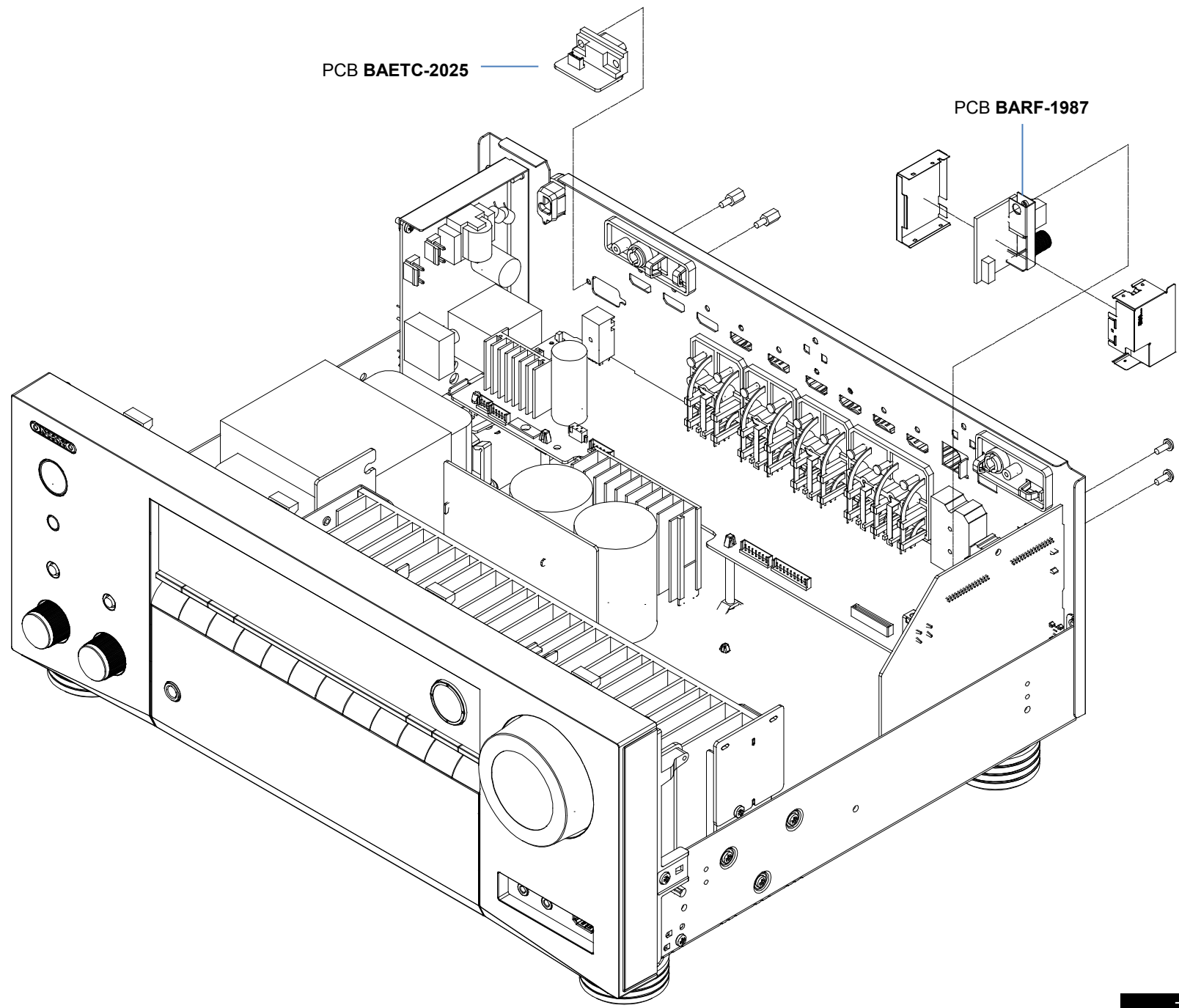

TX-NR555/656/757
TX-RZ610/710

Video-Speaker Section

This is TX-RZ710. TX-NR555/656//757/RZ610 is same mostly structurally. Please refer to PANEL pages for detailed place by the terminal.

Disassembly

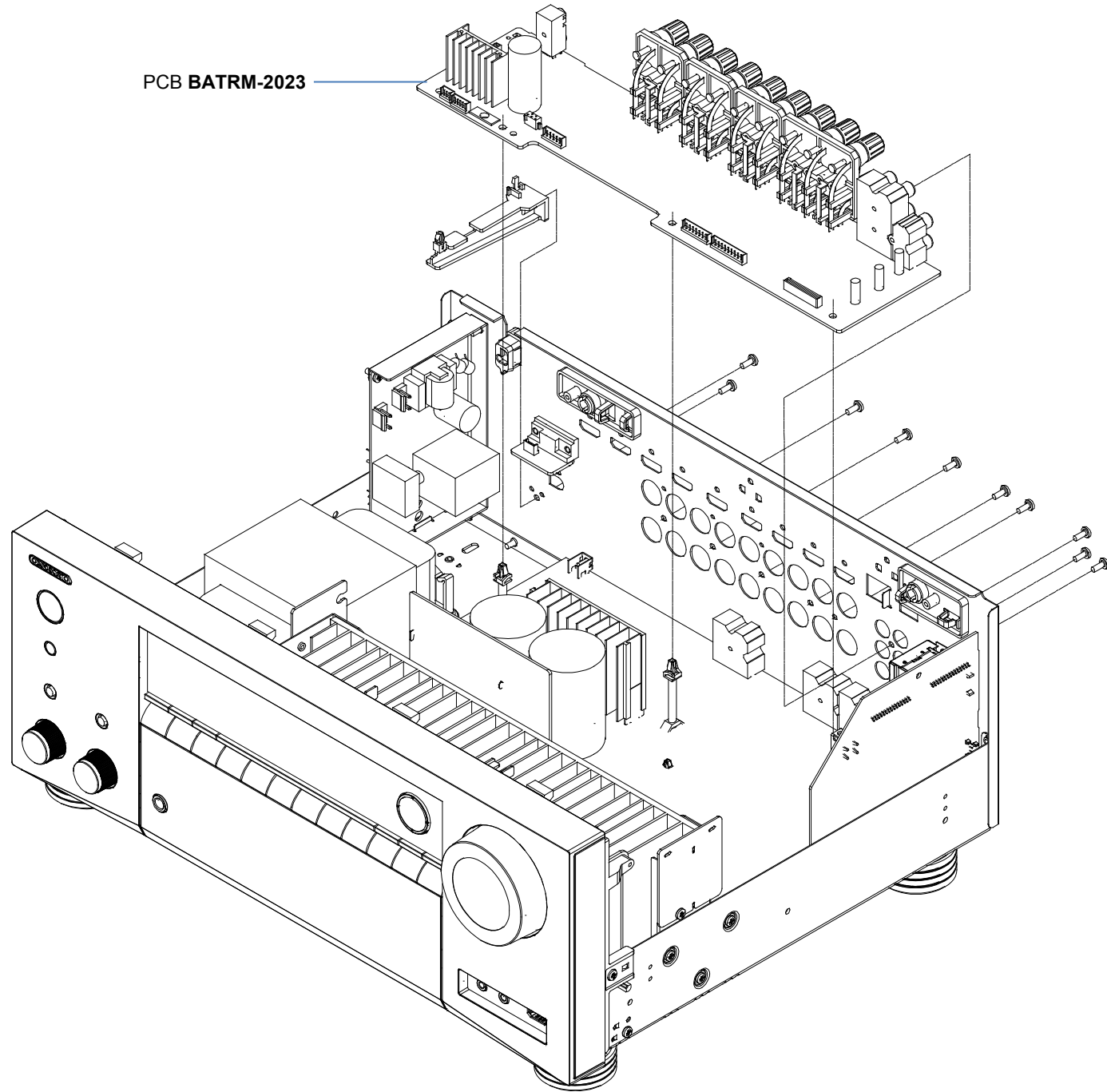

Digital Section

This is TX-RZ710. TX-NR555/656//757/RZ610 is same mostly structurally. Please refer to PANEL pages for detailed place by the terminal.

Disassembly

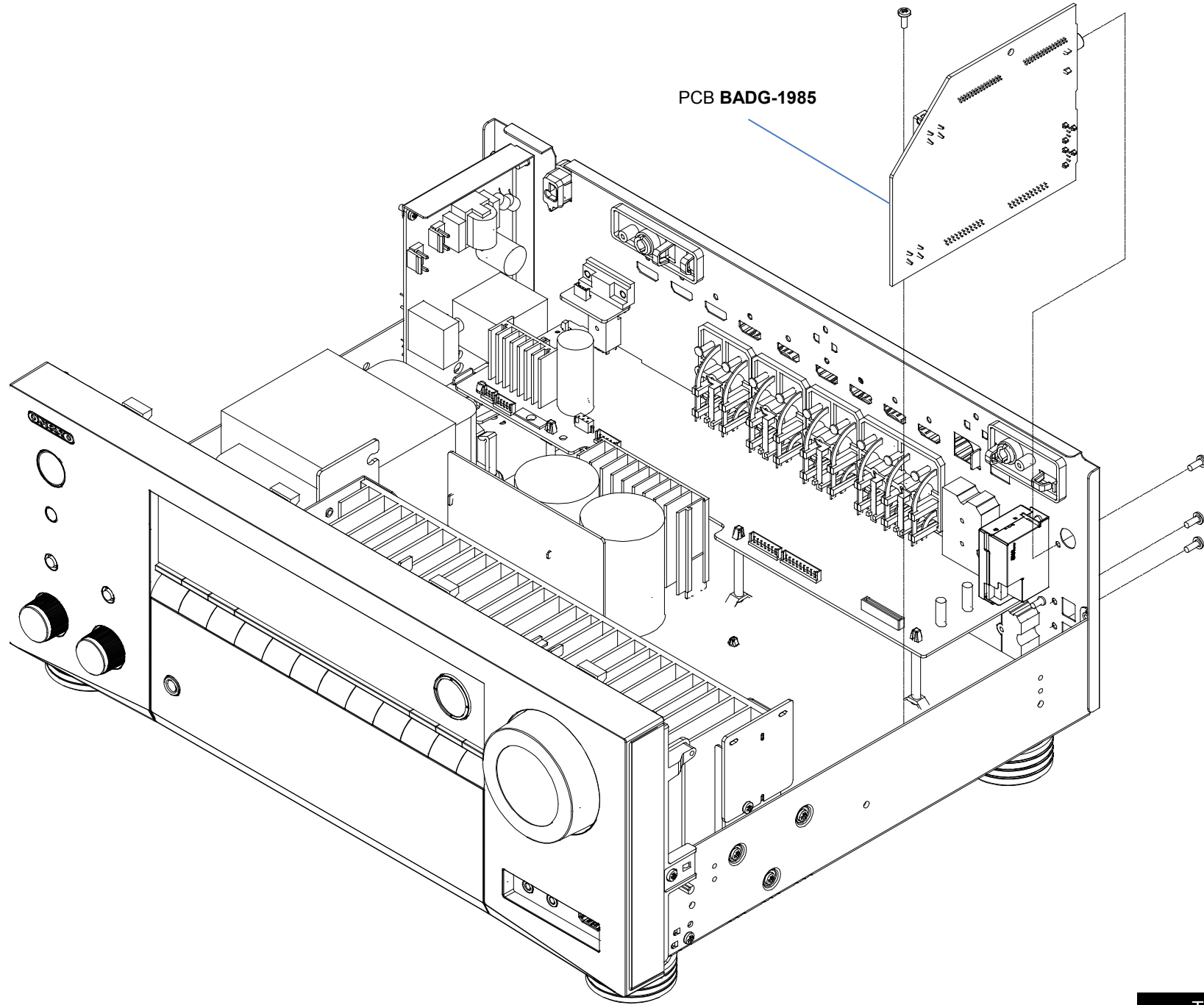

TX-NR555/656/757
TX-RZ610/710

Amplifier Section - 1

This is TX-RZ710. TX-NR555/656//757/RZ610 is same mostly structurally. Please refer to PANEL pages for detailed place by the terminal.

Disassembly

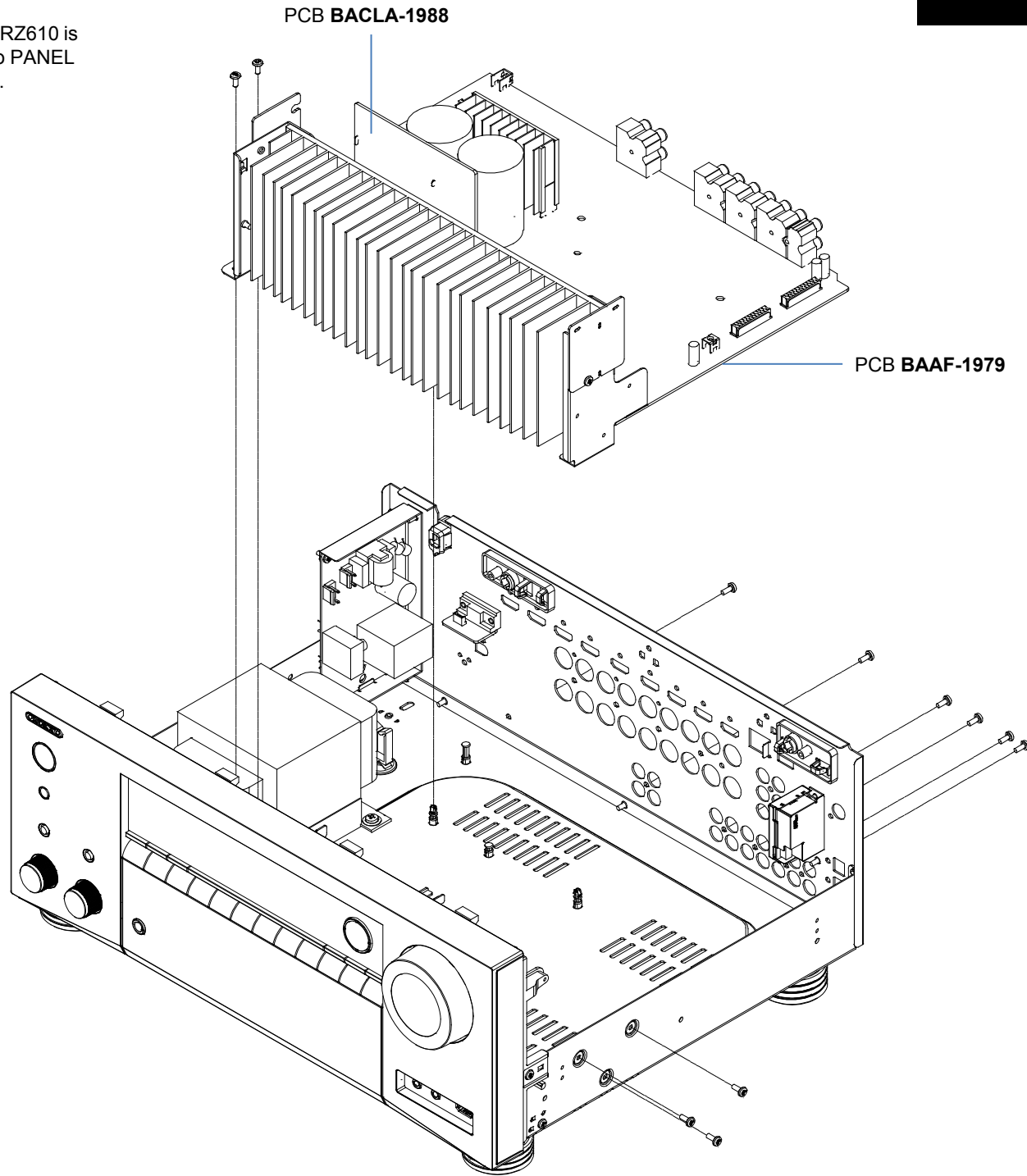

Amplifier Section - 2

This is TX-RZ710. TX-NR555/656//757/RZ610 is same mostly structurally. Please refer to PANEL pages for detailed place by the terminal.

Disassembly

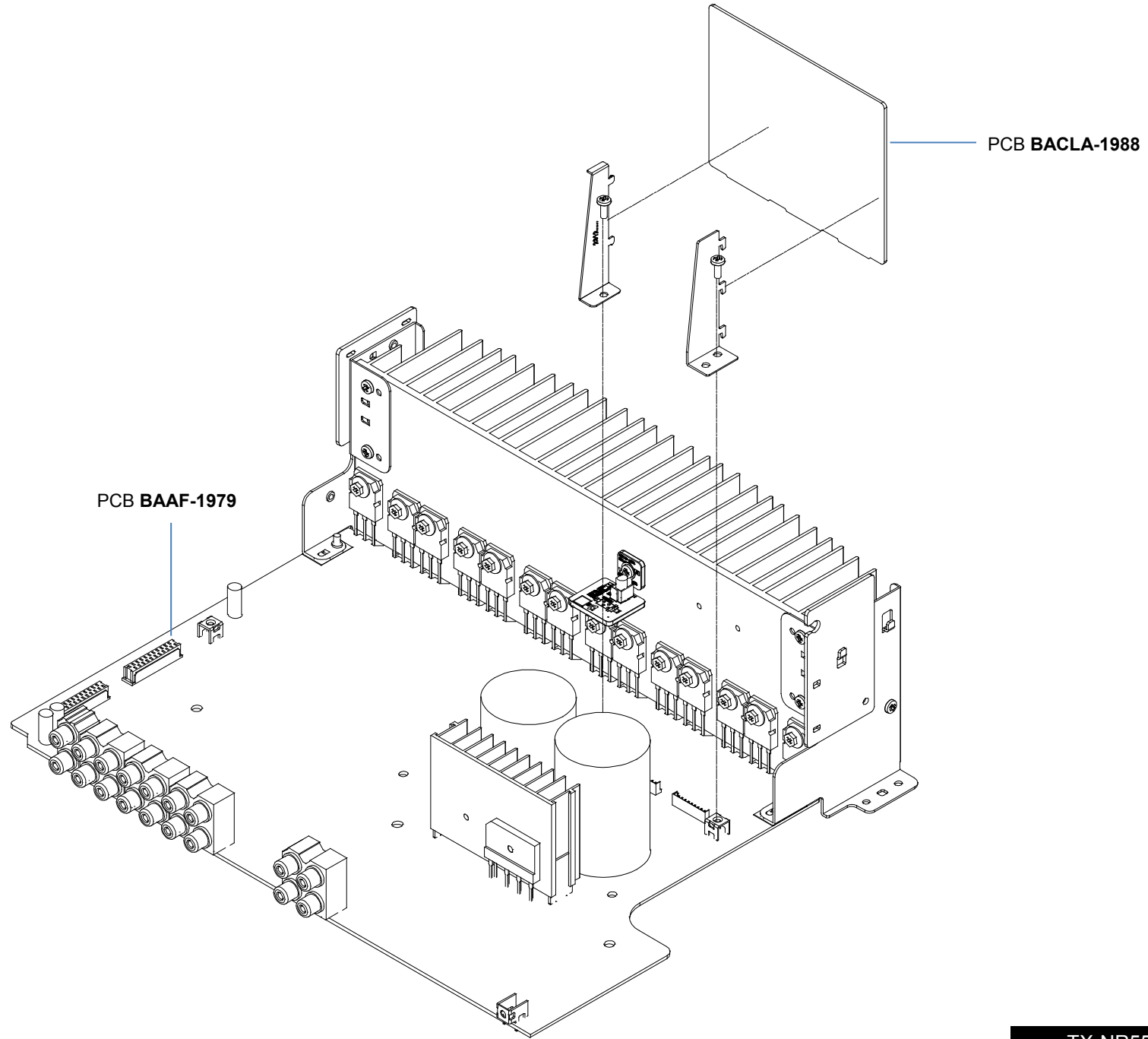

Amplifier Section - 3

This is TX-RZ710. TX-NR555/656//757/RZ610 is same mostly structurally. Please refer to PANEL pages for detailed place by the terminal.

Disassembly

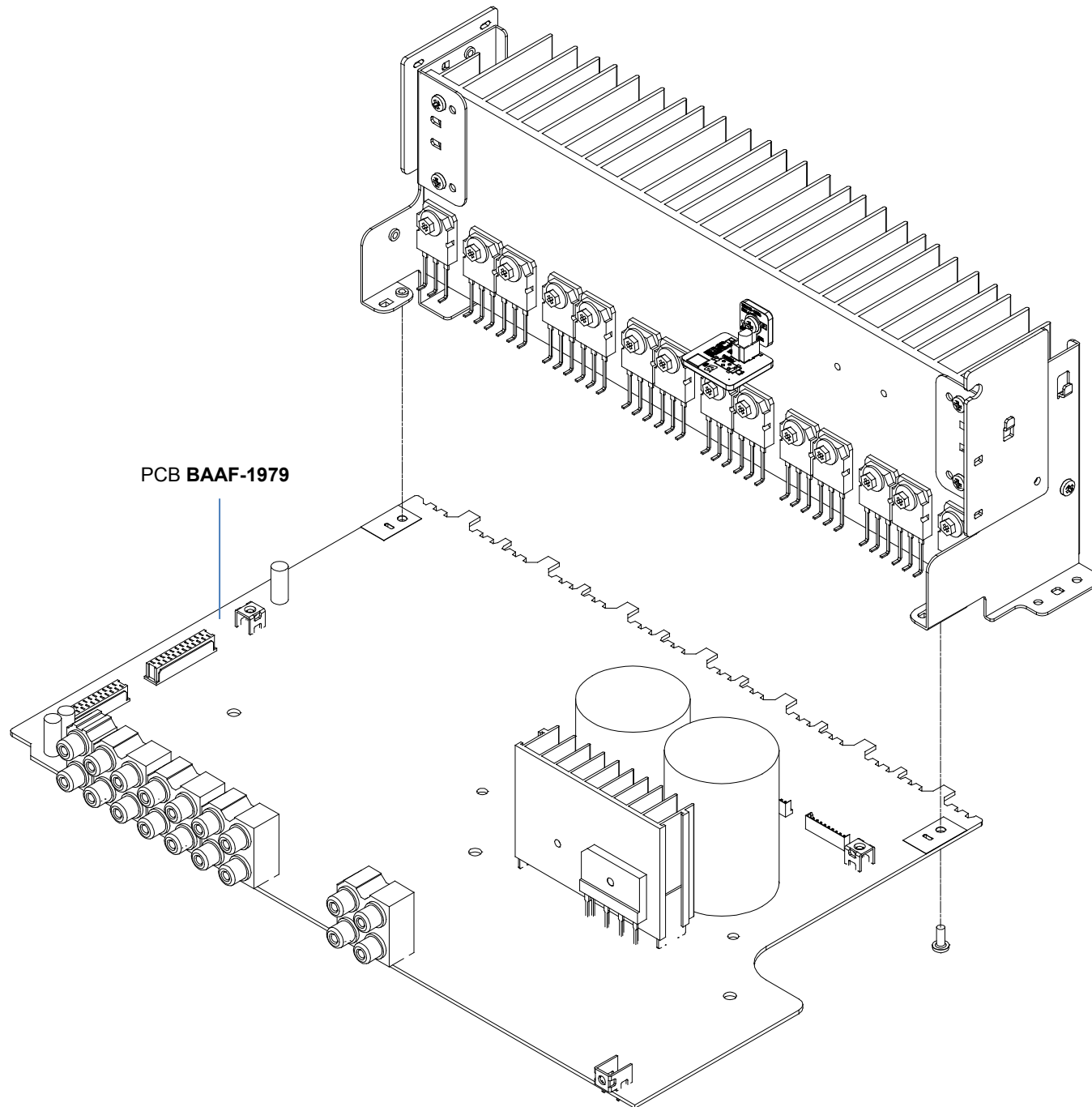

Amplifier Section - 4

This is TX-RZ710. TX-NR555/656//757/RZ610 is same mostly structurally. Please refer to PANEL pages for detailed place by the terminal.

Disassembly

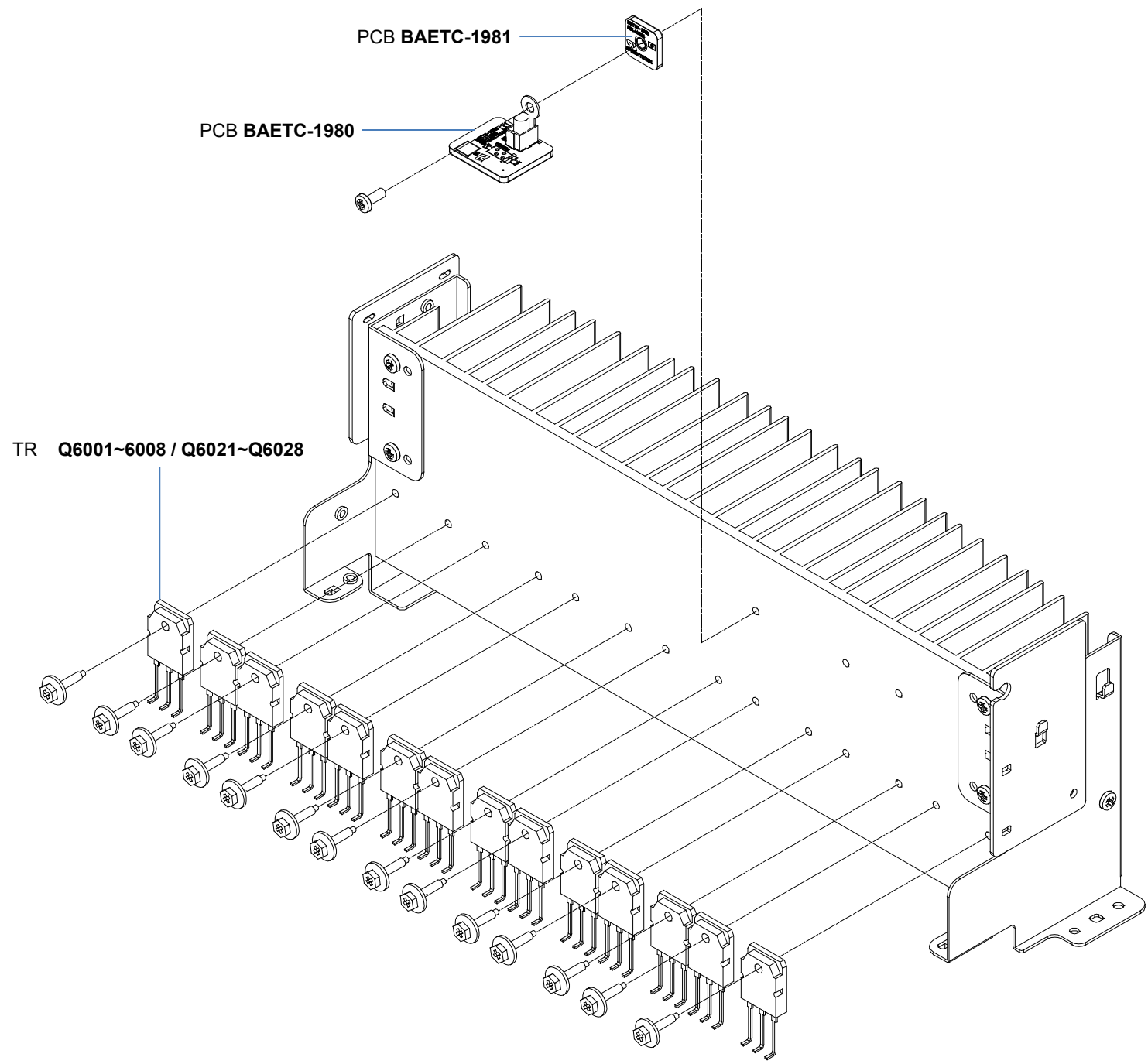

Model No. TX-NR555/656/757, TX-RZ610/710/810, HT-R695, DRX-2/3/4/5
Schematic Diagram List

PART NO.	FUNCTION	MODEL												
		T5	D2	V8	L1	T6	Z6	D3	V11	L3	T7	Z7	D4	Z8
	SCHEMATIC DIAGRAM LIST	YES	YES	YES	YES	YES	YES	YES	YES	YES	YES	YES	YES	YES
PART-1	AUDIO BLOCK	YES	YES	YES	YES	YES	YES	YES	YES	YES	YES	YES	YES	YES
PART-2	VIDEO BLOCK	YES	YES	YES	YES	YES	YES	YES	YES	YES	YES	YES	YES	YES
PART-3	DIGITAL AUDIO BLOCK	YES	YES	YES	YES	YES	YES	YES	YES	YES	YES	YES	YES	YES
PART-4	ASE	YES	YES	YES	YES	YES	YES	YES	YES	YES	YES	YES	YES	YES
	AMP. POWER	YES	YES	YES	YES	YES	YES	YES	YES	YES	YES	YES	YES	YES
	THERMAL SENSOR	YES	YES	YES	YES	YES	YES	YES	YES	YES	YES	YES	YES	YES
	DESTINATION LIST OF AP1979	YES	YES	YES	YES	YES	YES	YES	YES	YES	YES	YES	YES	YES
PART-5	AMP. CLASS-A	YES	YES	YES	YES	YES	YES	YES	YES	YES	YES	YES	YES	YES
PART-6	SWITCHING PS	YES	YES	YES	YES	YES	YES	YES	YES	YES	YES	YES	YES	YES
PART-7	VIDEO+SP_OUT+L2VTRG+IR RS-232C(D2/Z6/D3/L3/T7/Z7/D4/Z8/D5)	YES	YES	YES	YES	YES	YES	YES	YES	YES	YES	YES	YES	YES
PART-8	DISPLAY (T5/T6/Z6/T7/Z7)	YES	YES	YES	YES	YES	YES	YES	YES	YES	YES	YES	YES	YES
	HP (T5/T6/Z6/T7/Z7)	YES	YES	YES	YES	YES	YES	YES	YES	YES	YES	YES	YES	YES
	ZONE/LISTENING MODE SWITCH (T5/T6/Z6/T7/Z7)	YES	YES	YES	YES	YES	YES	YES	YES	YES	YES	YES	YES	YES
	DISPLAY (D2/D3/D4)	YES	YES	YES	YES	YES	YES	YES	YES	YES	YES	YES	YES	YES
	HP (D2/D3/D4)	YES	YES	YES	YES	YES	YES	YES	YES	YES	YES	YES	YES	YES
	FLAC/VH (D2/D3/D4)	YES	YES	YES	YES	YES	YES	YES	YES	YES	YES	YES	YES	YES
	STANDBY/ZONE SWITCH (D2/D3/D4)	YES	YES	YES	YES	YES	YES	YES	YES	YES	YES	YES	YES	YES
	DISPLAY (V8/L1/V11/L3)	YES	YES	YES	YES	YES	YES	YES	YES	YES	YES	YES	YES	YES
	HP (V8/L1/V11/L3)	YES	YES	YES	YES	YES	YES	YES	YES	YES	YES	YES	YES	YES
	INPUT SELECTOR SWITCH (V8/L1/V11/L3)	YES	YES	YES	YES	YES	YES	YES	YES	YES	YES	YES	YES	YES
	DISPLAY (Z8)	YES	YES	YES	YES	YES	YES	YES	YES	YES	YES	YES	YES	YES
	MASTER VOLUME (Z8)	YES	YES	YES	YES	YES	YES	YES	YES	YES	YES	YES	YES	YES
	SWITCH IN DOOR (Z8)	YES	YES	YES	YES	YES	YES	YES	YES	YES	YES	YES	YES	YES
	SWITCH etc. (Z8)	YES	YES	YES	YES	YES	YES	YES	YES	YES	YES	YES	YES	YES
	HP (Z8)	YES	YES	YES	YES	YES	YES	YES	YES	YES	YES	YES	YES	YES
	MIC (Z8)	YES	YES	YES	YES	YES	YES	YES	YES	YES	YES	YES	YES	YES
	FLAC/VH (Z8/D5)	YES	YES	YES	YES	YES	YES	YES	YES	YES	YES	YES	YES	YES
	DISPLAY (D5)	YES	YES	YES	YES	YES	YES	YES	YES	YES	YES	YES	YES	YES
	MASTER VOLUME (D5)	YES	YES	YES	YES	YES	YES	YES	YES	YES	YES	YES	YES	YES
	SWITCH/MIC (D5)	YES	YES	YES	YES	YES	YES	YES	YES	YES	YES	YES	YES	YES
	HP (D5)	YES	YES	YES	YES	YES	YES	YES	YES	YES	YES	YES	YES	YES
PART-9	DAC_FILTER+VLS1 (T5/D2/V8/L1/T6/Z6/V11/L3/T7/Z7/D4)	YES	YES	YES	YES	YES	YES	YES	YES	YES	YES	YES	YES	YES
	DAC_FILTER+VLS2 (Z8/D5)	YES	YES	YES	YES	YES	YES	YES	YES	YES	YES	YES	YES	YES
PART-10	MMPU	YES	YES	YES	YES	YES	YES	YES	YES	YES	YES	YES	YES	YES
	LVMPU	YES	YES	YES	YES	YES	YES	YES	YES	YES	YES	YES	YES	YES
	VSP	YES	YES	YES	YES	YES	YES	YES	YES	YES	YES	YES	YES	YES
	HDMI/DECODER	YES	YES	YES	YES	YES	YES	YES	YES	YES	YES	YES	YES	YES
	DIR/D&C	YES	YES	YES	YES	YES	YES	YES	YES	YES	YES	YES	YES	YES
	DSP	YES	YES	YES	YES	YES	YES	YES	YES	YES	YES	YES	YES	YES
	ARM_I/O	YES	YES	YES	YES	YES	YES	YES	YES	YES	YES	YES	YES	YES
	ARM_PS	YES	YES	YES	YES	YES	YES	YES	YES	YES	YES	YES	YES	YES
	ARM_MEMORY	YES	YES	YES	YES	YES	YES	YES	YES	YES	YES	YES	YES	YES
	ARM_USB/NET	YES	YES	YES	YES	YES	YES	YES	YES	YES	YES	YES	YES	YES
	POWER	YES	YES	YES	YES	YES	YES	YES	YES	YES	YES	YES	YES	YES
PART-11	TUNER	YES	YES	YES	YES	YES	YES	YES	YES	YES	YES	YES	YES	YES
PART-12	FRONT_HDMI (T6/Z6/D3/V11/L3/T7/Z7/D4)	YES	YES	YES	YES	YES	YES	YES	YES	YES	YES	YES	YES	YES
	FRONT_HDMI (Z8/D5)	YES	YES	YES	YES	YES	YES	YES	YES	YES	YES	YES	YES	YES
PART-13	HDBaseT (D4/D5)	YES	YES	YES	YES	YES	YES	YES	YES	YES	YES	YES	YES	YES

Model name	Abbreviated Model Name
TX-NR555	T5
DRX-2	D2
TX-NR656, HT-R695	T6
TX-RZ610	Z6
DRX-3	D3
TX-NR757	T7
TX-RZ710	Z7
DRX-4	D4
TX-RZ810	Z8
DRX-5	D5

Block diagram (Analog audio)

Schematic Diagram

MODEL NO.TX-NR555/656/757, TX-RZ610/710/810, HT-R695, DRX-2/3/4/5 SCHEMATIC DIAGRAM(PART-1) BLOCK DIAGRAM(Analog Audio)

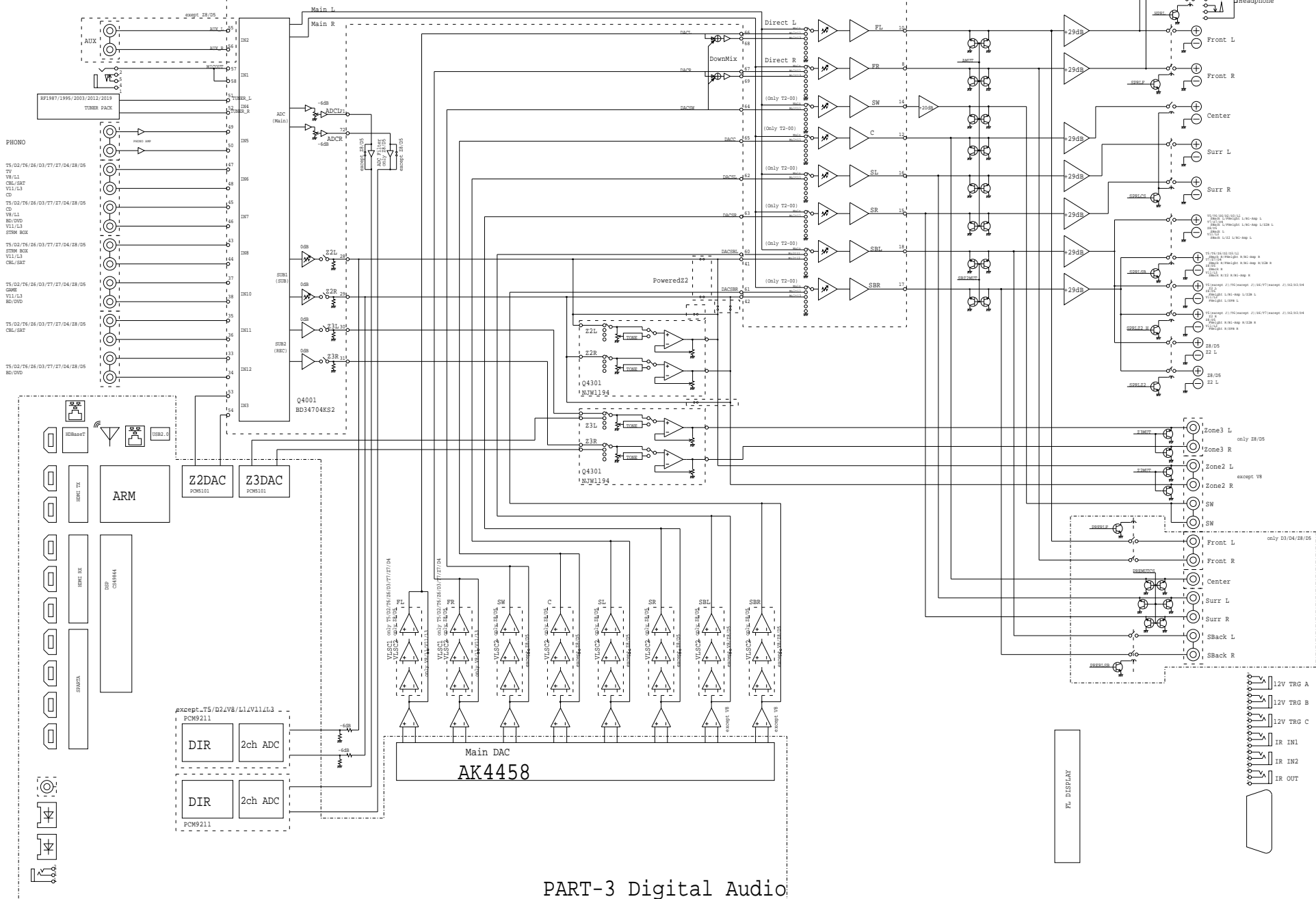

PART-3 Digital Audio

MODEL NO. TX-NR555/656/757, TX-RZ610/710/810, HT-R695, DRX-2/3/4/5

SCHEMATIC DIAGRAM (PART-2) BLOCK DIAGRAM(Video)

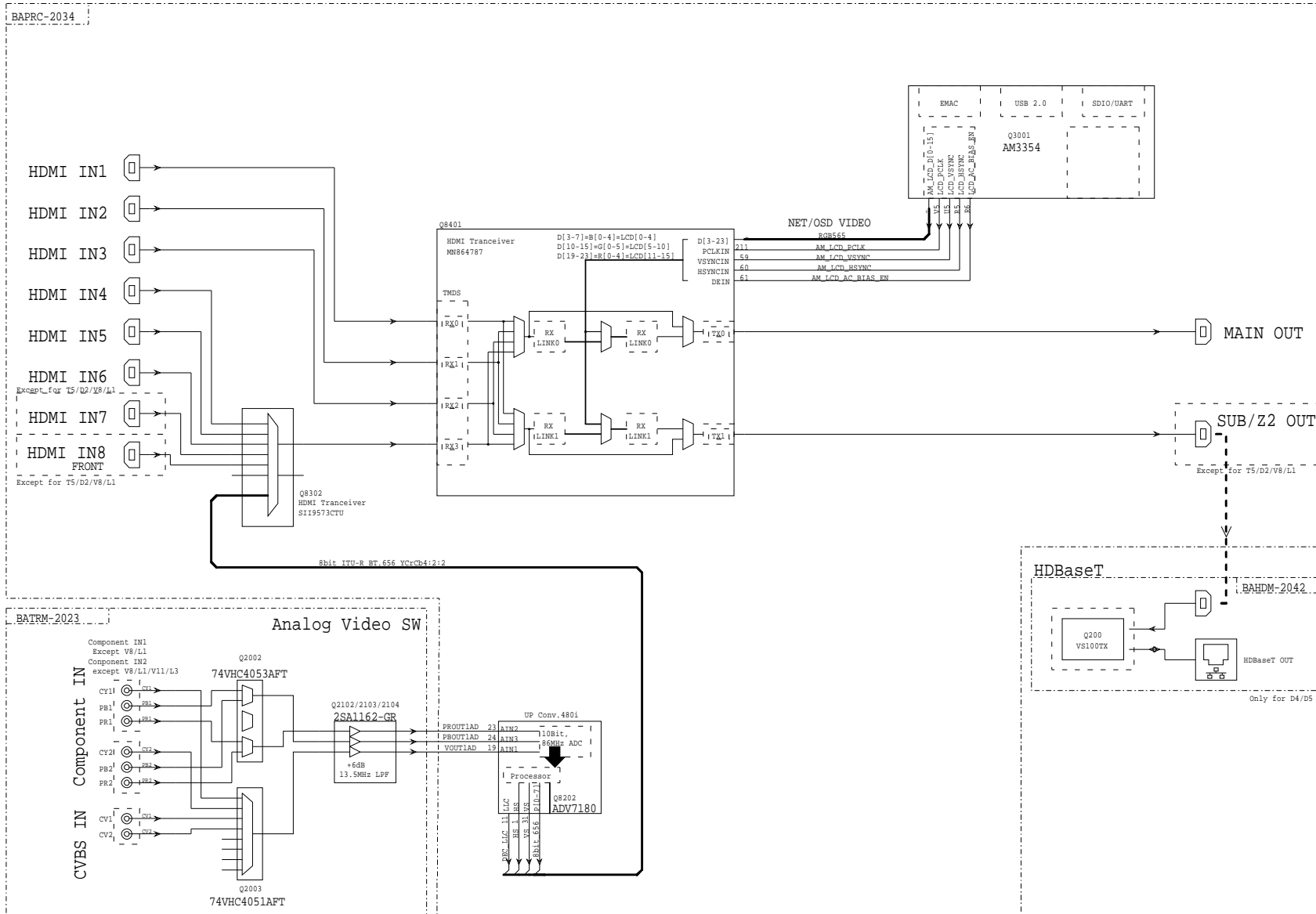

MODEL NO.TX-NR555/656/757,TX-RZ610/710/810,HT-R695 SCHEMATIC DIAGRAM (PART-3) BLOCK DIAGRAM(Digital Audio)
DRX-2/3/4/5

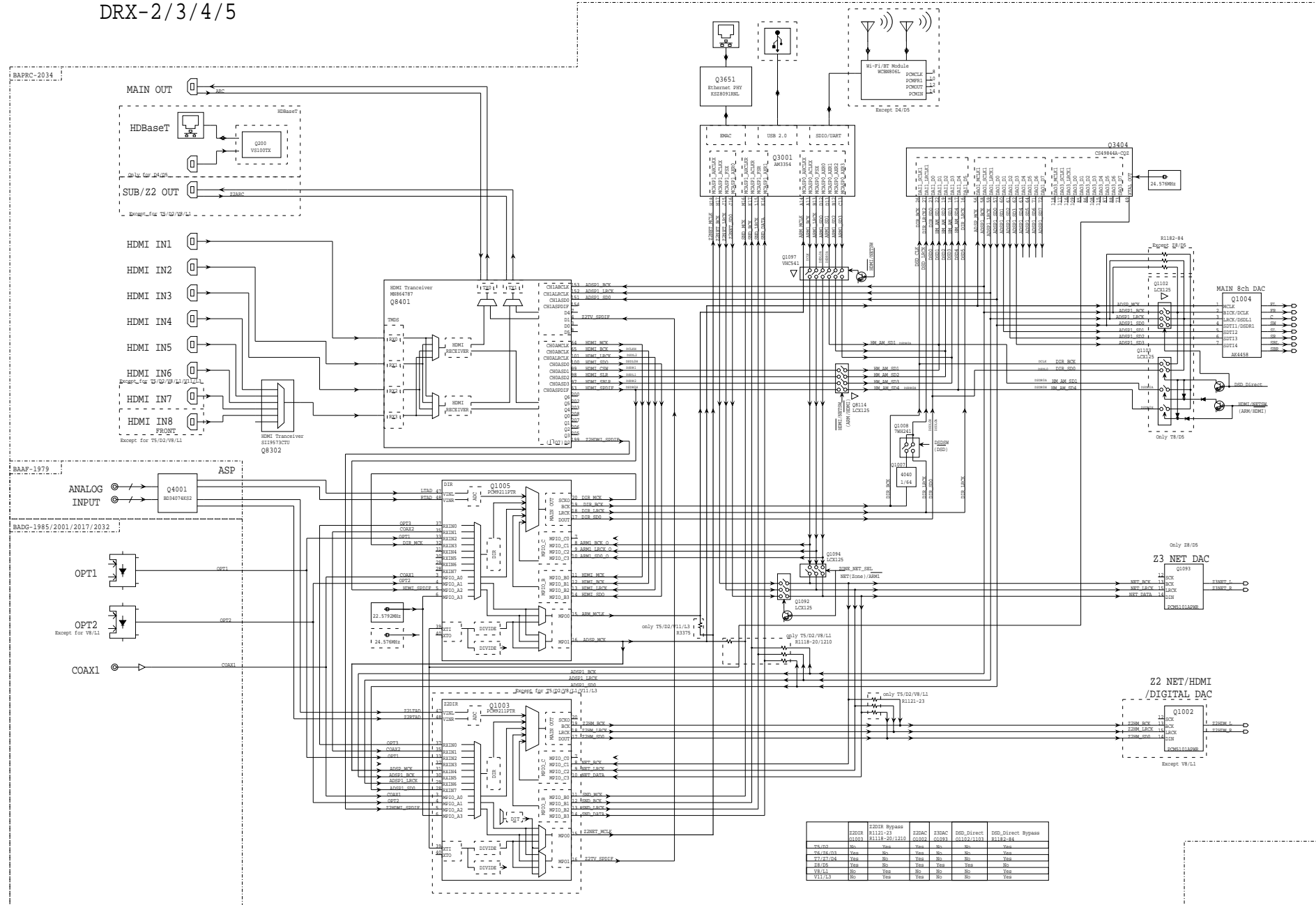

MODELNO. TX-NR555/656/757, TX-RZ610/710/810, HT-R695, DRX-2/3/4/5 SCHEMATIC DIAGRAM (PART-4) ASP SECTION

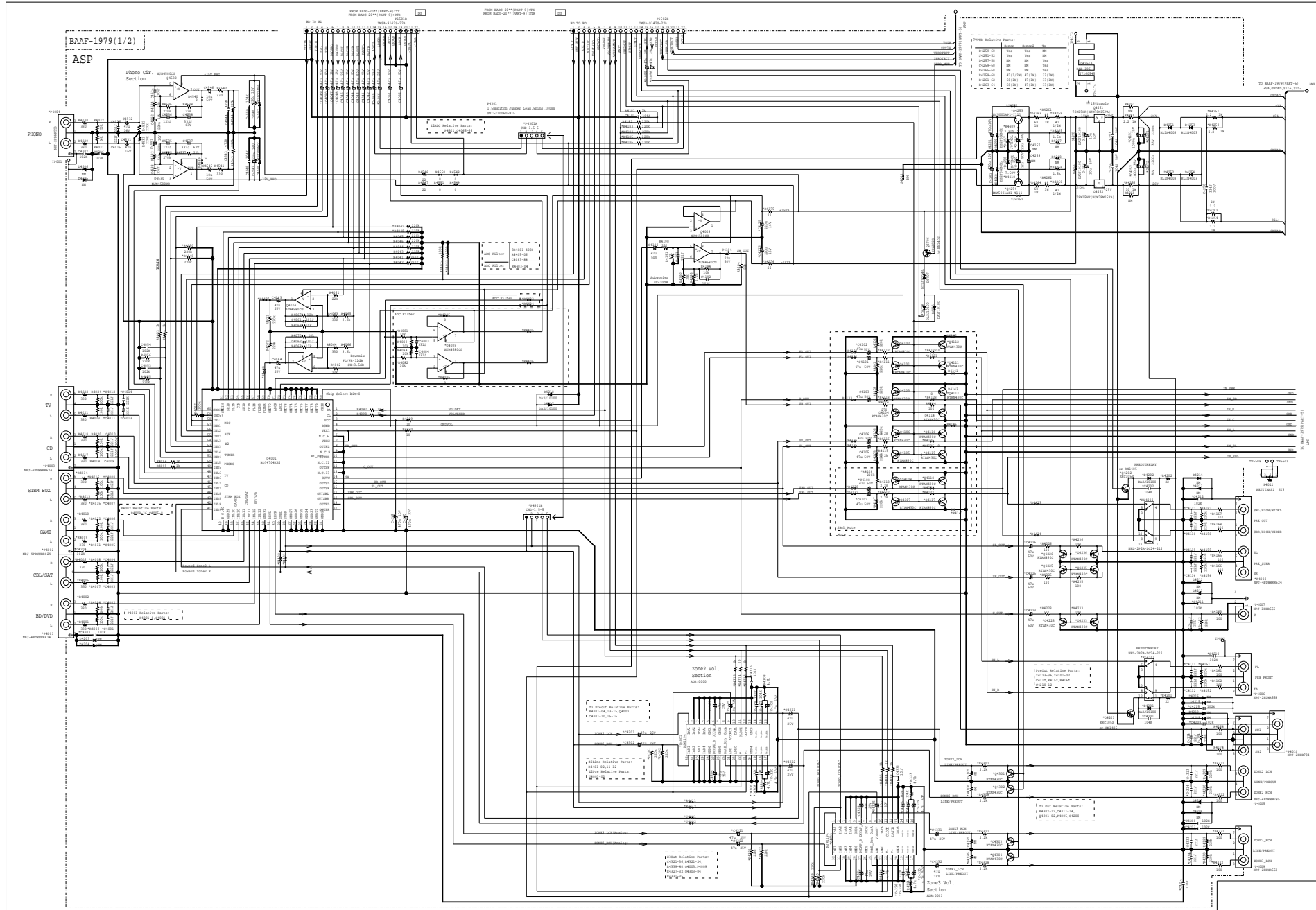

MODELNO.TX-NR555/656/757, TX-RZ610/710/810, HT-R695, DRX-2/3/4/5 SCHEMATIC DIAGRAM (PART-4) AMP SECTION

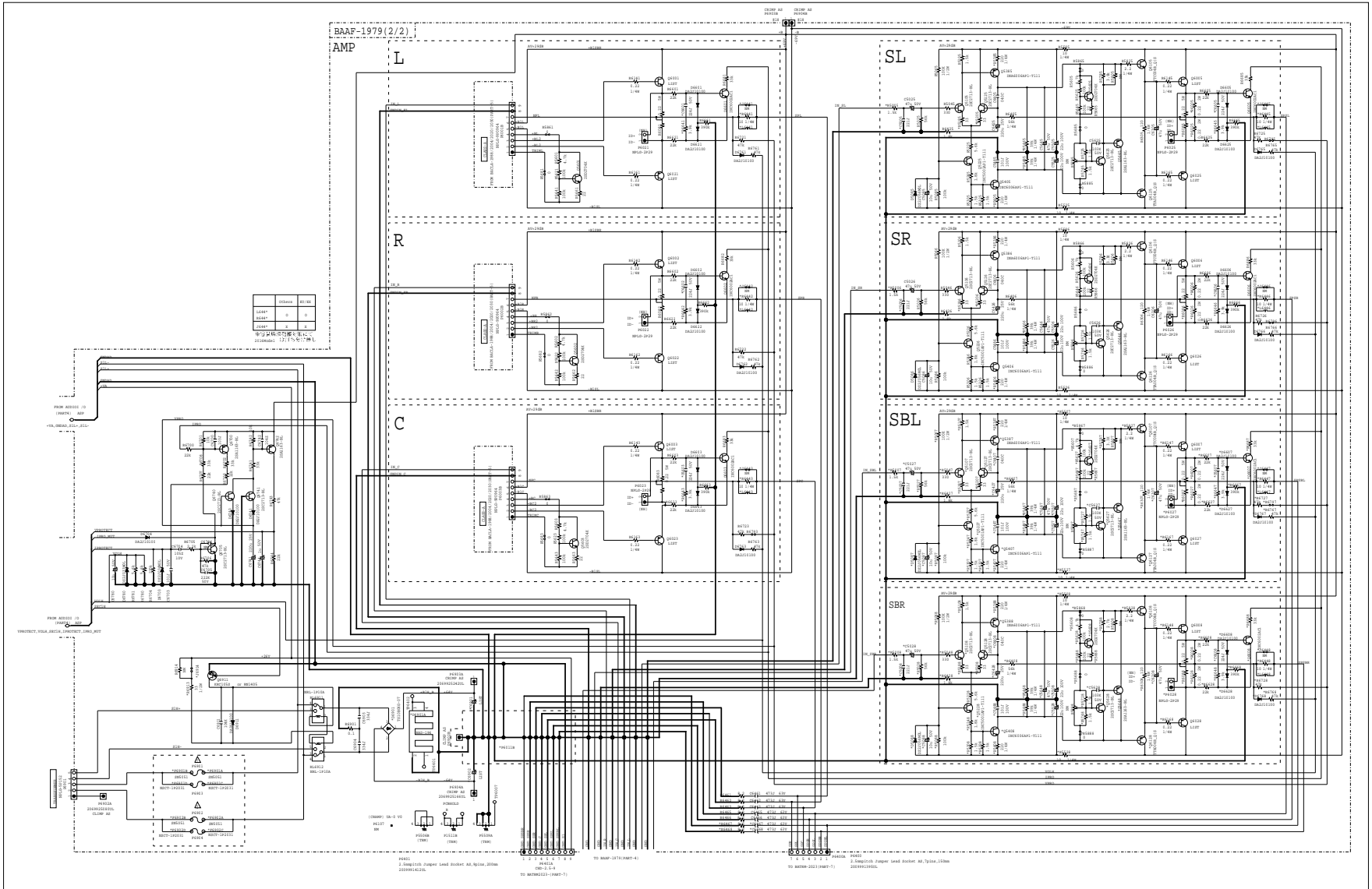

MODEL NO. TX-NR555/656/757, TX-RZ610/710/810,
HT-R695, DRX-2/3/4/5

SCHEMATIC DIAGRAM (PART-4)
THERMAL SENSOR SECTION

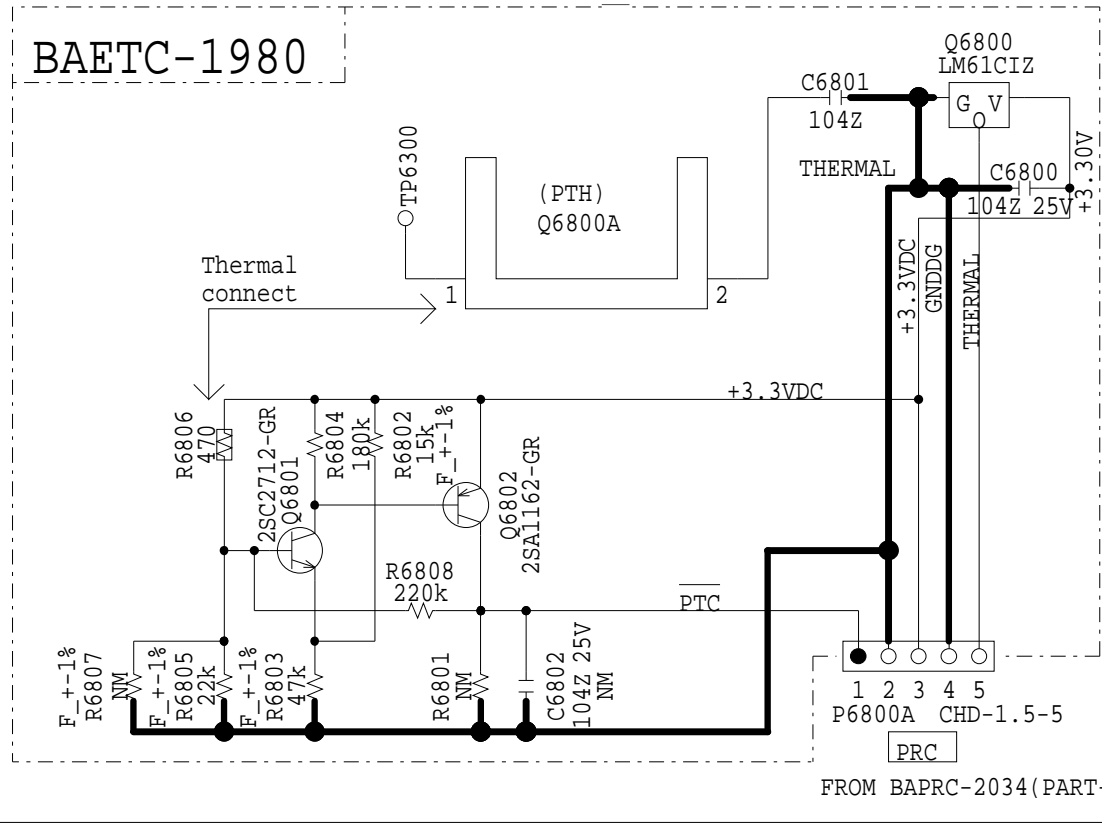

Destination list of BAAR-1979

Schematic Diagram

Functions	Cir.No/Group	T5	D2	T6	Z6	D3	T7	Z7	D4	T8	D5	V8	L1	V11	L3
Input Terminal	Terminal Color	Silver	Gold	Silver	Gold	Silver	Gold	Silver	Gold	Silver	Gold	Silver			
	P4001,P4002 Relatives	Mount P4001 and P4002 Relatives										NM	Mount P4002 Relatives		
	P4001,P4002	25045845	25045812	25045845	25045812	25045845	25045812	25045845	25045812	25045845	25045812	NM	25045845		
	C4011-12,C4013-14	C4011-12										C4011-12	C4013-14		
AUX Audio Input	R4033,R4034	Mount							NM		Mount				
Mute	SBch_Mute	Mount										NM	Mount		
	R4111-13,15-18	2.2k			120	2.2k			120			2.2k			
	R4112-23,25-28	0			100	0			100			0			
	Q4112-23,25-28	NM			Mount	NM			Mount			NM			
Pre Out	P4006	NM			25045803	NM		25045803	25045776	25045803		NM			
	P4007	NM			25045998	NM		25045998	25045774	25045998		NM			
	P4008	NM			25045812	NM		25045812	25045845	25045812		NM			
	Z2Pre/Line	Z2Out Relatives	Mount										NM	Mount	
	P4010,C4215	NM										Mount	NM		
	Z2Line Relatives	Mount	NM	Mount	NM		Mount	NM			NM		Mount	NM	
	Z2Pre Relatives	NM	Mount	NM	Mount		NM	Mount			NM		NM	Mount	
	Z3Vol Relatives	NM							Mount		NM				
ADC Filter		ADC Filter							ADC Filter		ADC Filter				
Z2ADC	Relatives	NM						Mount			NM				
15VPWR	R4251-54	2.2 1W (*Z7/D4M:0.22 1/2W)							0.22 1/2W		2.2 1W				
	R4256	10 1W							2.2 1W		10 1W				
	C4271-72	1000uF35V							2200uF35V		1000uF35V				
7VPWR Relatives		Zener	Zene2	Transistor							Zener		Transistor		
Amp	SBL/SBR C4047-48,R4047-48	Mount										NM	Mount		
Block Cap	C6901-02	3504506 6800u 63V	3504525A 8200u 69V	3504519A 8200u 69V	3504534 10000u 71V	3504525A 8200u 69V	3504539 10000u 75V	3504540 10000u 75V	3504539 10000u 75V	3504535 15000u 75V	3504515 15000u 75V	3504506 6800u 63V		3504525A 8200u 69V	
Power Tr	Q6001-03	2SC5198		2SC5242						TTC0001		2SC5198		2SC5242	
	Q6021-23	2SA1941		2SA1962						TTA0001		2SA1941		2SA1962	
	Q6005-08	2SC5198		KTC5242A			2SC5242			TTC0001		2SC5198		KTC5242A	
	Q6025-28	2SA1941		KTA1962A			2SA1962			TTA0001		2SA1941		KTA1962A	
AMP Emitter Resistor	R6005-08,R6025-28 R6085-88	Mount NM					NM Mount					Mount NM			
IPRO	R664*	3.9k		2.2k					1.8k		3.9k		2.2k		
Fuse	F6901-02 Label	10A-UL/T-233 10A/125V		12A-TUL-250V			15A-TUL-250V 15A/250V			10A-UL/T-233 10A/125V		12A-TUL-250V			
Heatsink	D6901A	27160545					27160500					27160545			
BUS Plate	27142306A	NM					Mount					NM			

Destination List of BAAF-1979

MODEL NO. TX-NR555/656/757, TX-RZ610/710/810, HT-R695, DRX-2/3/4/5

SCHEMATIC DIAGRAM(PART-5) AMP SECTION

BACLA-1988 TX-NR555/656/757, TX-RZ610/710, HT-R695
 BACLA-2004 DRX-2/3/4
 BACLA-2030 TX-RZ810, DRX-5

CLASS A

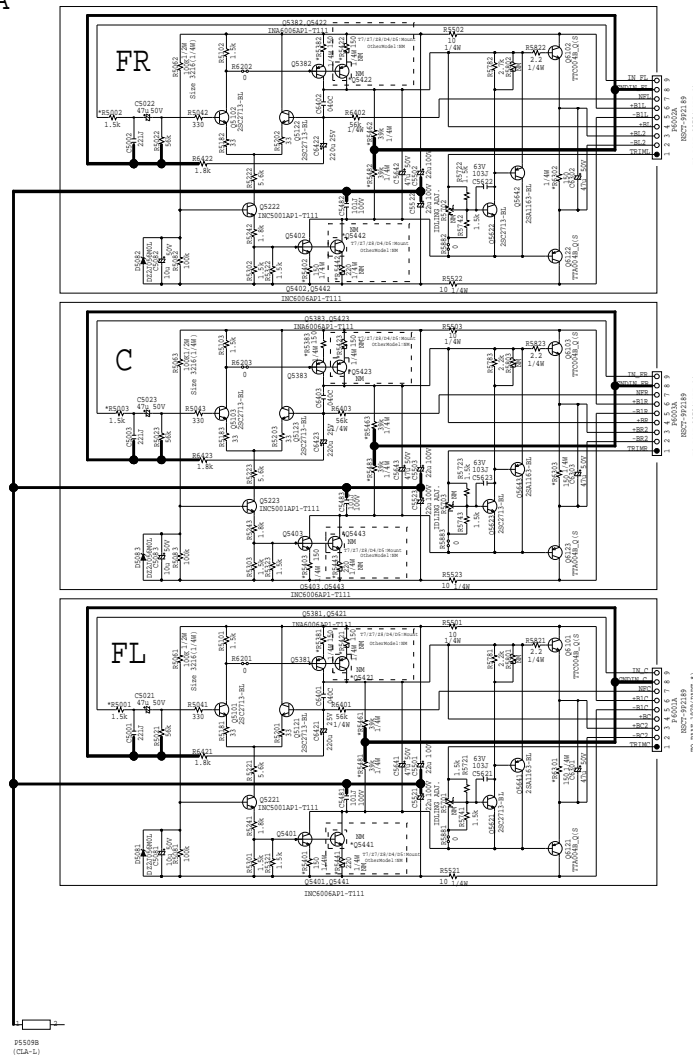

Destination table

Destination Model	MODEL			
	T5/T2/T6/D4/ V8/V3/V11/L3	T7/T7	D3	D4/D4/D4
R500*	1.5K Ω			3.3K Ω
R540*		220 Ω		
R541*			220 Ω	
R544*	No Mount	220 Ω	No Mount	220 Ω
R546*	39K Ω	33K Ω	39K Ω	33K Ω
R548*				33K Ω
R630*	150 Ω			
Q542*	No Mount	Mount	No Mount	Mount
Q544*				

MODEL NO. TX-NR555/656/757, TX-RZ610/710/810, HT-R695, DRX-2/3/4/5
SCHEMATIC DIAGRAM (PART-6)

PS SECTION

THE COMPONENTS IDENTIFIED MARK Δ ARE CRITICAL FOR SAFETY, REPLACE ONLY WITH PART NUMBER SPECIFIED.
VOLTAGE (MEASURED WITH VOLTMETER) IS DC VOLTAGE. (NO INPUT SIGNAL)
ELECTROLYTIC CAPACITORS (∇) ARE IN μ F/VV.
ALL CAPACITORS ARE IN pF/50V UNLESS OTHERWISE NOTED.
EX) 030 \rightarrow 3pF, 330 \rightarrow 33pF, 331 \rightarrow 330pF, 333 \rightarrow 0.033 μ F
CIRCUIT IS SUBJECT TO CHANGE FOR IMPROVEMENT.

CAUTION
FOR CONTINUED PROTECTION AGAINST FIRE HAZARD,
REPLACE ONLY WITH FUSE OF SAME TYPE AND RATING INDICATED.

ATTENTION
AFIN D'ASSURER UNE PROTECTION PERMANENTE CONTRE LES RISQUES D'INCENDIE,
REMPLACER UNIQUEMENT PAR UN FUSIBLE DE MEME TYPE ET CALIBRATION COMME INDIQUE.

THIS SYMBOL LOCATED NEAR THE FUSE INDICATES THAT THE FUSE USED IS SLOW OPERATING TYPE FOR CONTINUED PROTECTION AGAINST FIRE HAZARD, REPLACE WITH SAME TYPE FUSE.
RATING REFER TO THE MARKING ADJACENT TO THE SYMBOL.

CE SYMBOLE INDIQUE QUE LE FUSIBLE UTILISE EST A LENT, E POUR UNE PROTECTION PERMANENTE, N'UTILISER QUE DES FUSIBLES DE MEME TYPE.
CE DERNIER EST INDIQUE LA QU LE PRESENT SYMBOLE EST APOSE.

Δ 印は火災、感電の危険に關する部品の為、必ず指定部品を使用の事。
電圧表示は無信号時に測定した直流電圧を示す。
記入なき電解コンデンサの単位は μ F/50Vである。
記入なきコンデンサの単位はpF/50Vである。
例) 030 \rightarrow 3pF, 330 \rightarrow 33pF, 331 \rightarrow 330pF, 333 \rightarrow 0.033 μ F
本配線図は基本配線図につき性能改善等により予告なく変更する事がある。

MODEL	MODEL
T5	TX-NR555
T6	TX-NR656, HT-R695
Z6	TX-RZ610
T7	TX-NR757
Z7	TX-RZ710
Z8	TX-RZ810
D2	DRX-2
D3	DRX-3
D4	DRX-4
D5	DRX-5
V8	VSK-831
L1	VSK-LX101
V11	VSK-V1131
L3	VSK-LX301

BAPS-1984 (TX-NR555/NR656/NR757/RZ610/RZ710, HT-R695)
BAPS-2000 (DRX-2/3/4)
BAPS-2031 (TX-RZ810, DRX-5)

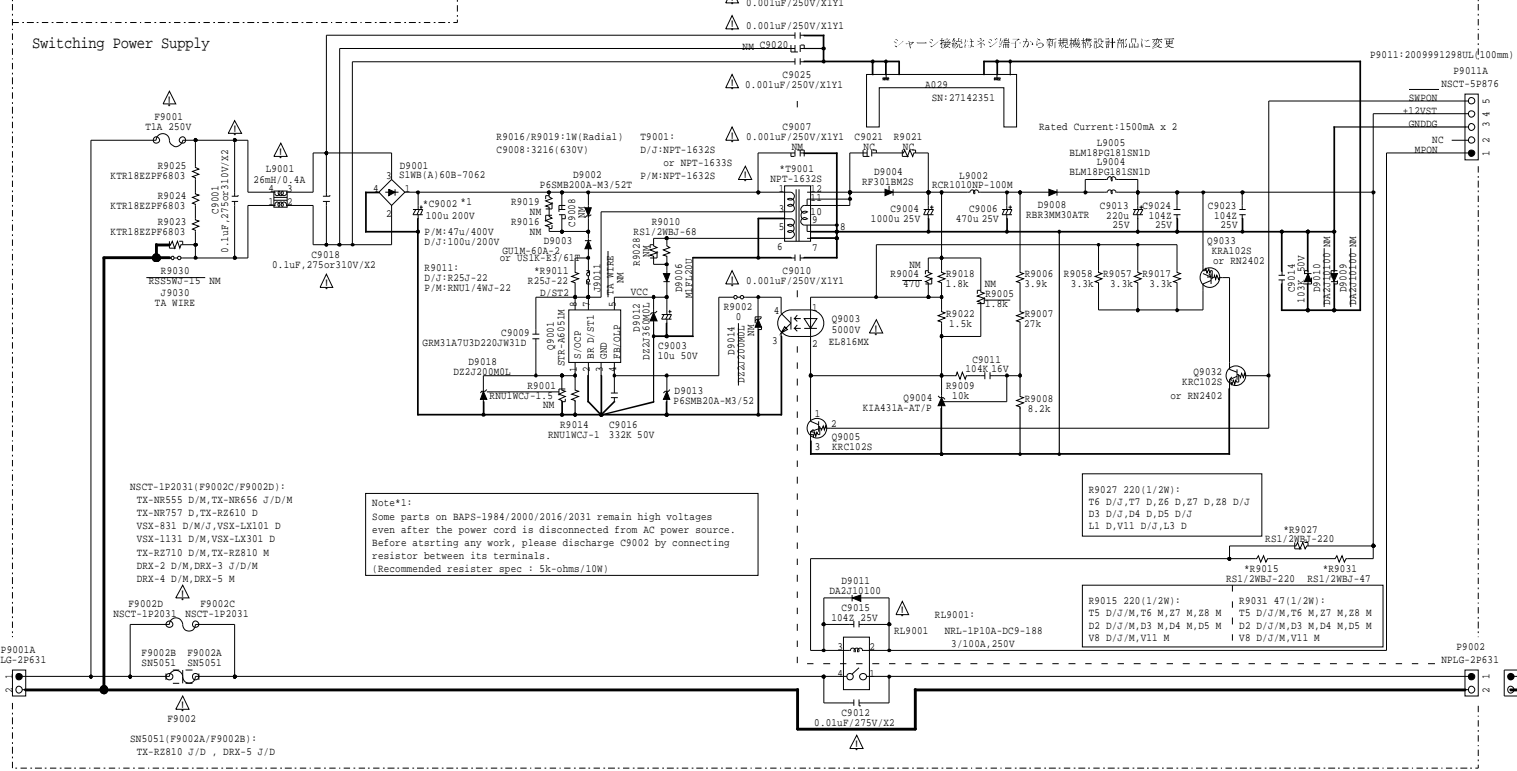

TYPE	AC POWER
D	120Vac, 60Hz
M	220-240Vac, 50/60Hz
J	100Vac, 50/60Hz

MODEL	Destination	AC POWER IN	AC CORD	INLET
T5	All	○	○	○
T6	MDF/MJ/L Other	○	○	○
T7	All	○	○	○
Z6	All	○	○	○
Z7	MMA/AMPL Other	○	○	○
Z8	All	○	○	○
D2	All	○	○	○
D3	All	○	○	○
D4	All	○	○	○
D5	All	○	○	○
V8	All	○	○	○
V11	MDF Other	○	○	○
L1	All	○	○	○
L3	All	○	○	○

F9002:Rating of Fuse

TYPE	T5/D2	V8	L1	T6/D3	Z6/T7	T7/D4/V11	L3	Z8/D5
D	8A 125V 29360842	8A 125V 29360842	8A 125V 29360842	10A 125V 29362241	10A 125V 29362241	10A 125V 29362241	10A 125V 29362241	10A 125V 29362241
M	T2, 5A/250V 29361747	T2, 5A/250V 29361747	---	T5AL250V 29361938	---	T3, 15A/250V 29362779	---	T4AL250V 29362779
J	---	8A 125V 29360842	---	12A 125V 29392136	---	---	---	15A 250V 29362952

T901 Rating

TYPE	T5/D2	V8	L1	T6/D3	V11	Z6/L3	T7	T7/D4	Z8/D5
D	NPT-1664D	NPT-1664D	NPT-1664D	NPT-1671D	NPT-1671D	NPT-1671D	NPT-1672D	NPT-1672D	NPT-1665D
M	NPT-1664M	NPT-1664M	NPT-1664M	NPT-1671M	NPT-1671M	NPT-1671M	NPT-1672M	NPT-1672M	NPT-1665M
J	NPT-1664J	NPT-1664J	NPT-1664J	NPT-1671J	NPT-1671J	NPT-1671J	NPT-1672J	NPT-1672J	NPT-1665J

BATRM-2023 (PART-7)

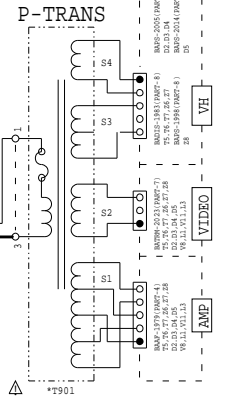

MODEL NO. TX-NR555/656/757, TX-RZ610/710/810, HT-R695, DRX-2/3/4/5 SCHEMATIC DIAGRAM(PART-7) VIDEO, SPOUT, IR/12VTRG SECTION

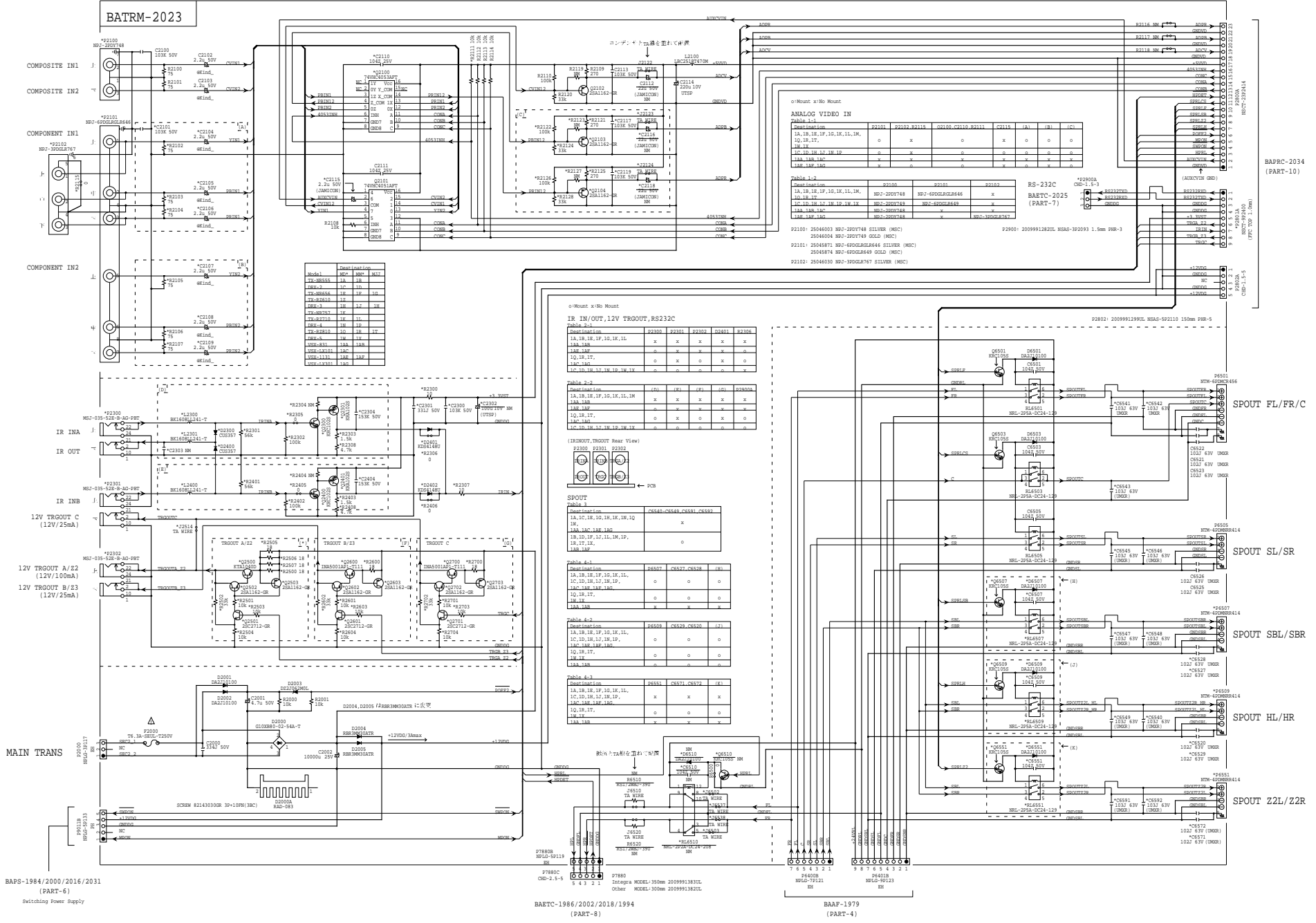

MODEL NO. TX-NR555/656/757, TX-RZ610/710/810, DRX-2/3/4/5, HT-R695,
 SCHEMATIC DIAGRAM(PART-7) RS232C SECTION

BAETC-2025

Model	Destination
TX-NR555	1A 1B
DRX-2	1C 1D
TX-NR656	1E 1F 1G
TX-NR610	1Z
DRX-3	1H 1J 1H
TX-NR757	1K
TX-RZ710	1K 1L
DRX-4	1N 1P
TX-RZ810	1Q 1R 1T
DRX-5	1W 1X
VSX-831	1AA 1AB
VSX-LX101	1AC
VSX-1131	1AE 1AF
VSX-LX301	1AG

RS-232C

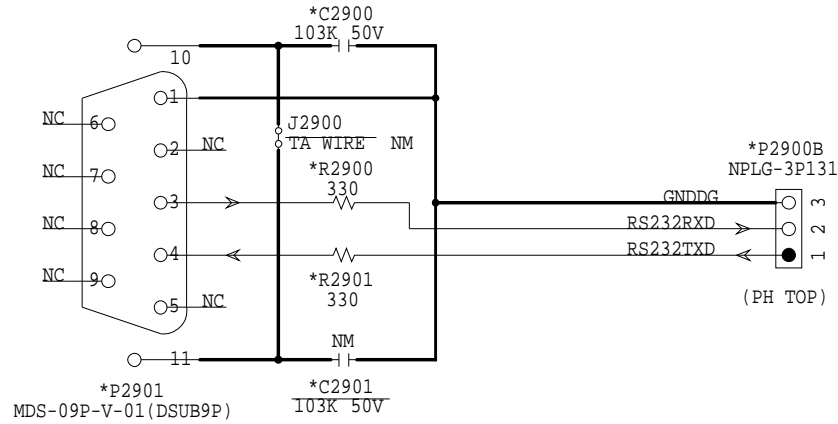

BATRM-2023
(PART-7)

Destination	P2900B, P2901, C2900, R2900, R2901
1A, 1B, 1E, 1F, 1G, 1K, 1L, 1M, 1AA, 1AB, 1AE, 1AF	All Mount
1Q, 1R, 1T, 1C, 1D, 1H, 1J, 1N, 1P, 1W, 1X, 1AC, 1AG	All No Mount

MODEL NO. TX-NR555/656/757, TX-RZ610/710, HT-R695 SCHEMATIC DIAGRAM(PART-8) DISPLAY SECTION

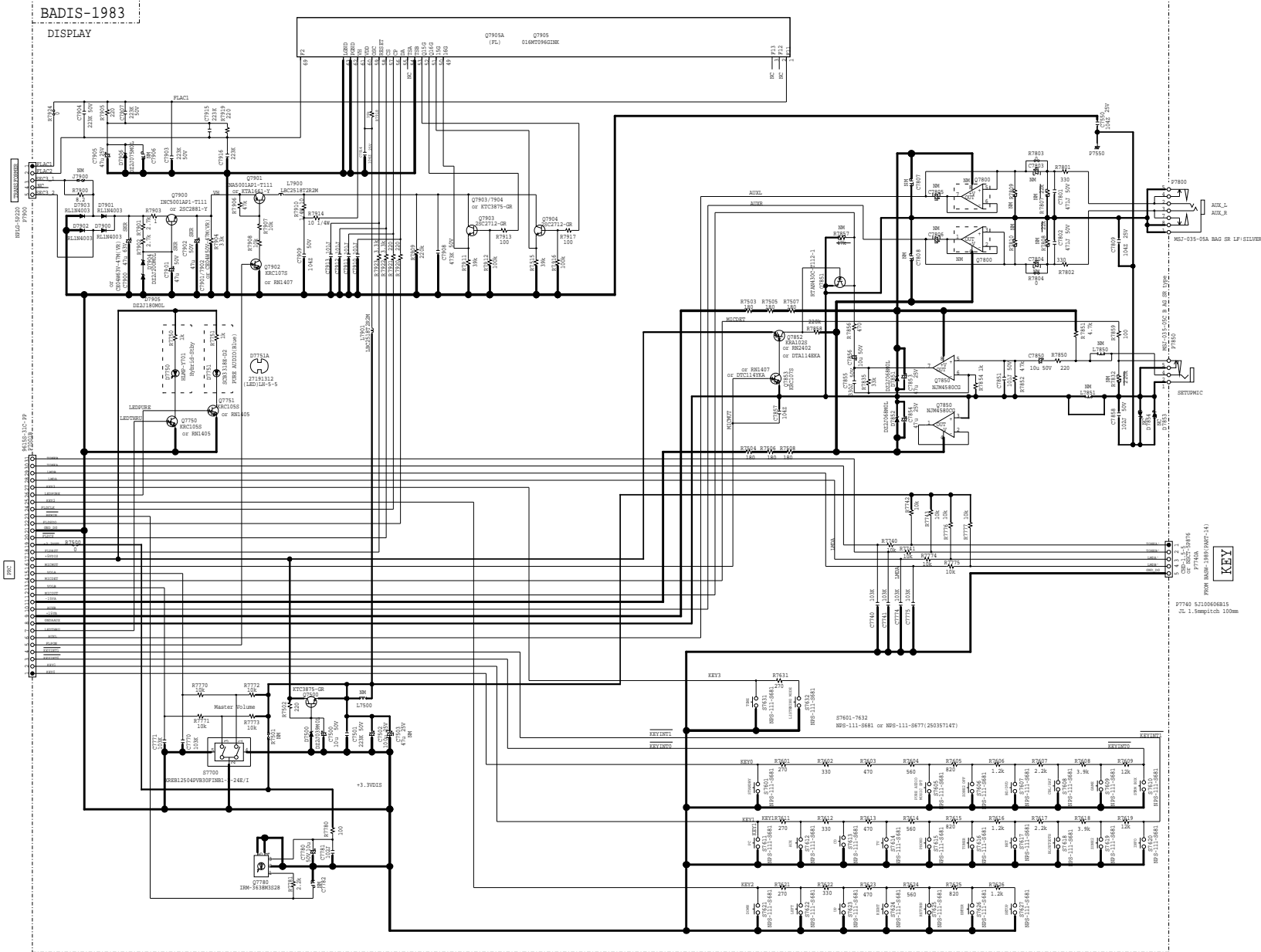

MODEL NO. TX-NR555/656/757, TX-RZ610/710, HT-R695
SCHEMATIC DIAGRAM(PART-8) DISPLAY(HEADPHONE)SECTION

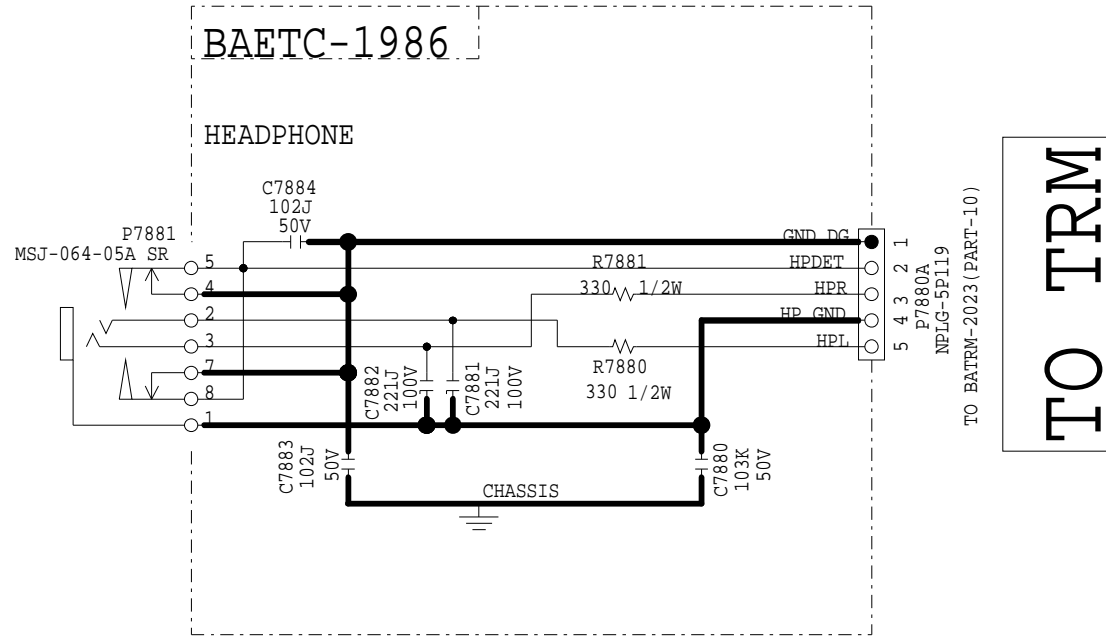

MODEL NO. TX-NR555/656/757, TX-RZ610/710, HT-R695
SCHEMATIC DIAGRAM(PART-8) DISPLAY(Encoder)SECTION

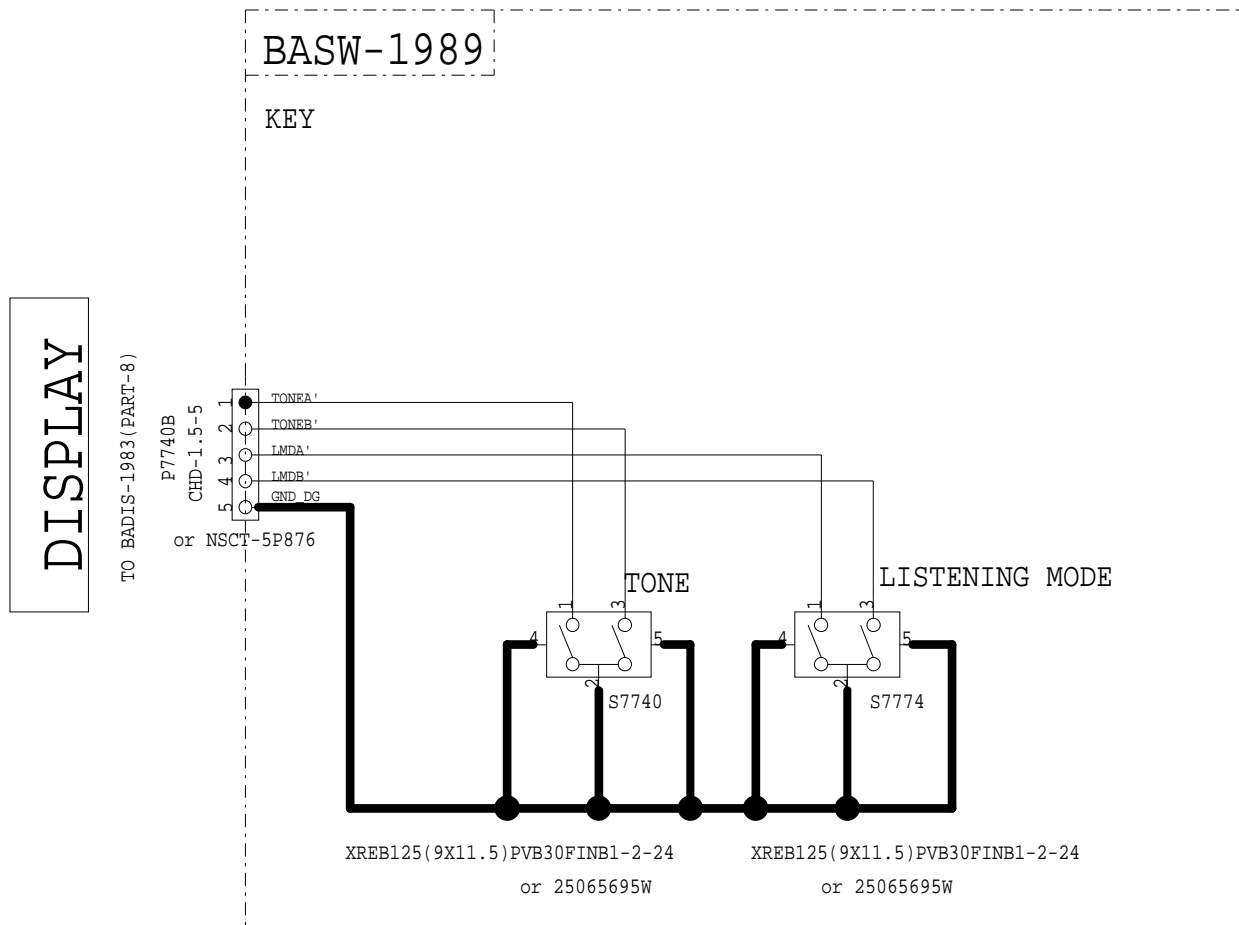

MODEL NO. DRX-2/3/4 SCHEMATIC DIAGRAM(PART-8) DISPLAY SECTION

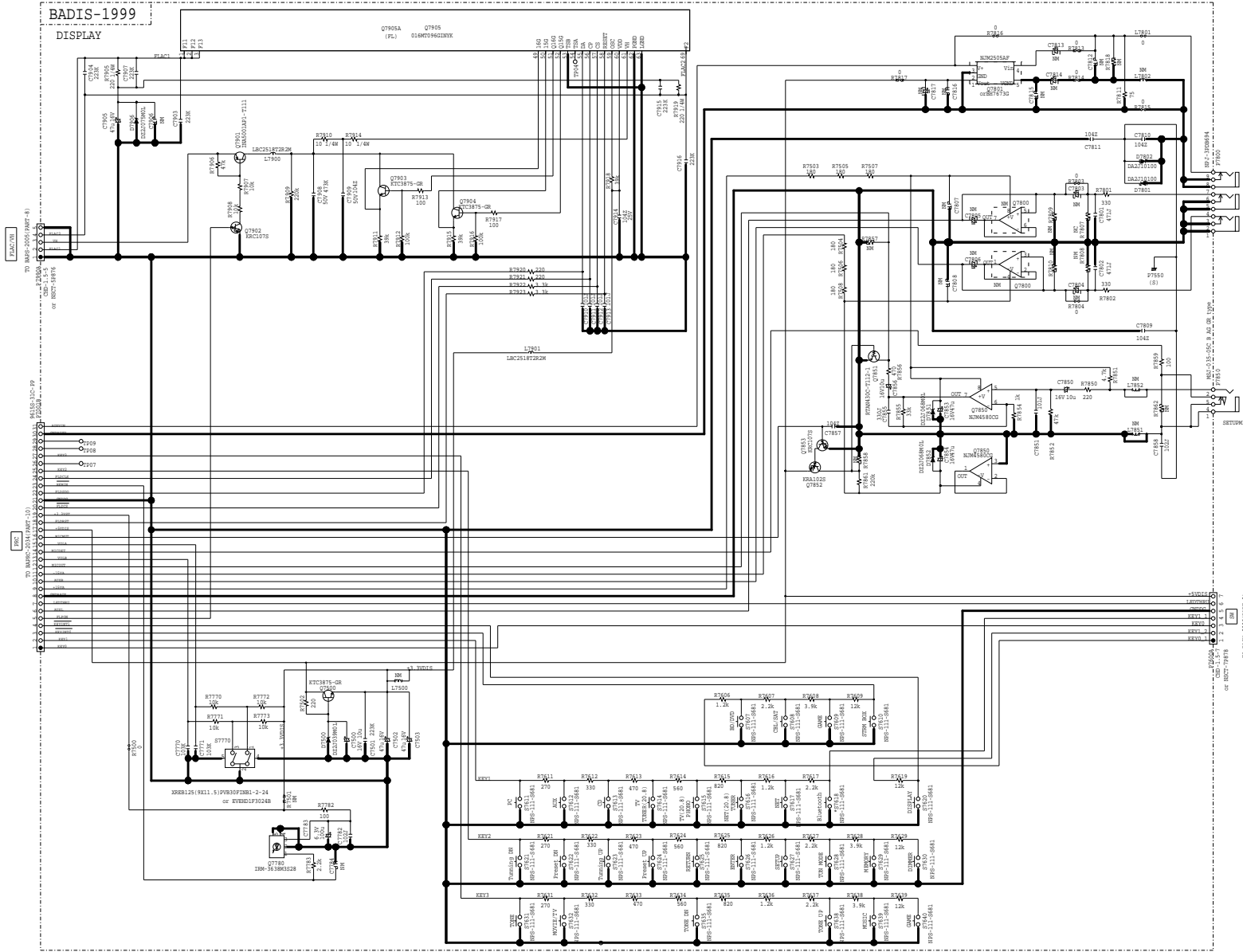

MODEL NO.DRX-2/3/4
SCHEMATIC DIAGRAM(PART-8)
DISPLAY (HEADPHONE) SECTION

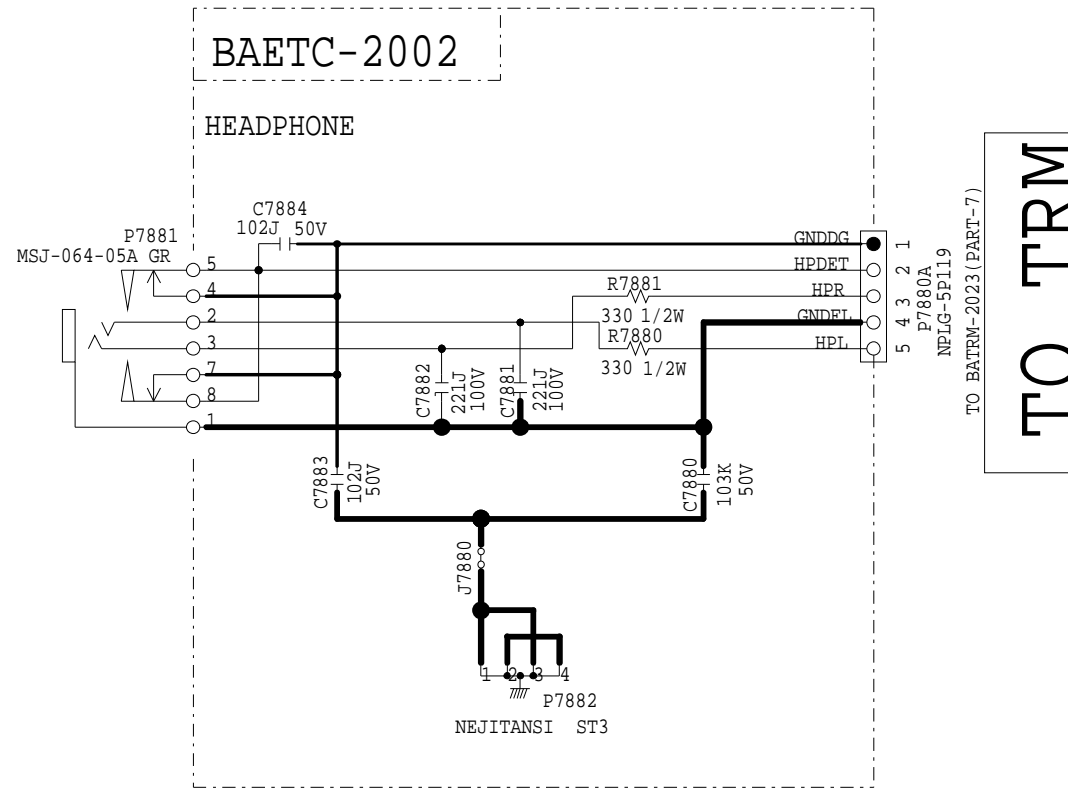

TO TRM

Display (Power supply) section

Schematic Diagram

Model No. TX-RZ810, DRX-2/3/4/5 SCHEMATIC DIAGRAM (PART-8)
 DISPLAY(Power supply) SECTION

BAPS-1998 (TX-RZ810)
 BAPS-2005 (DRX-2/3/4)
 BAPS-2014 (DRX-5)

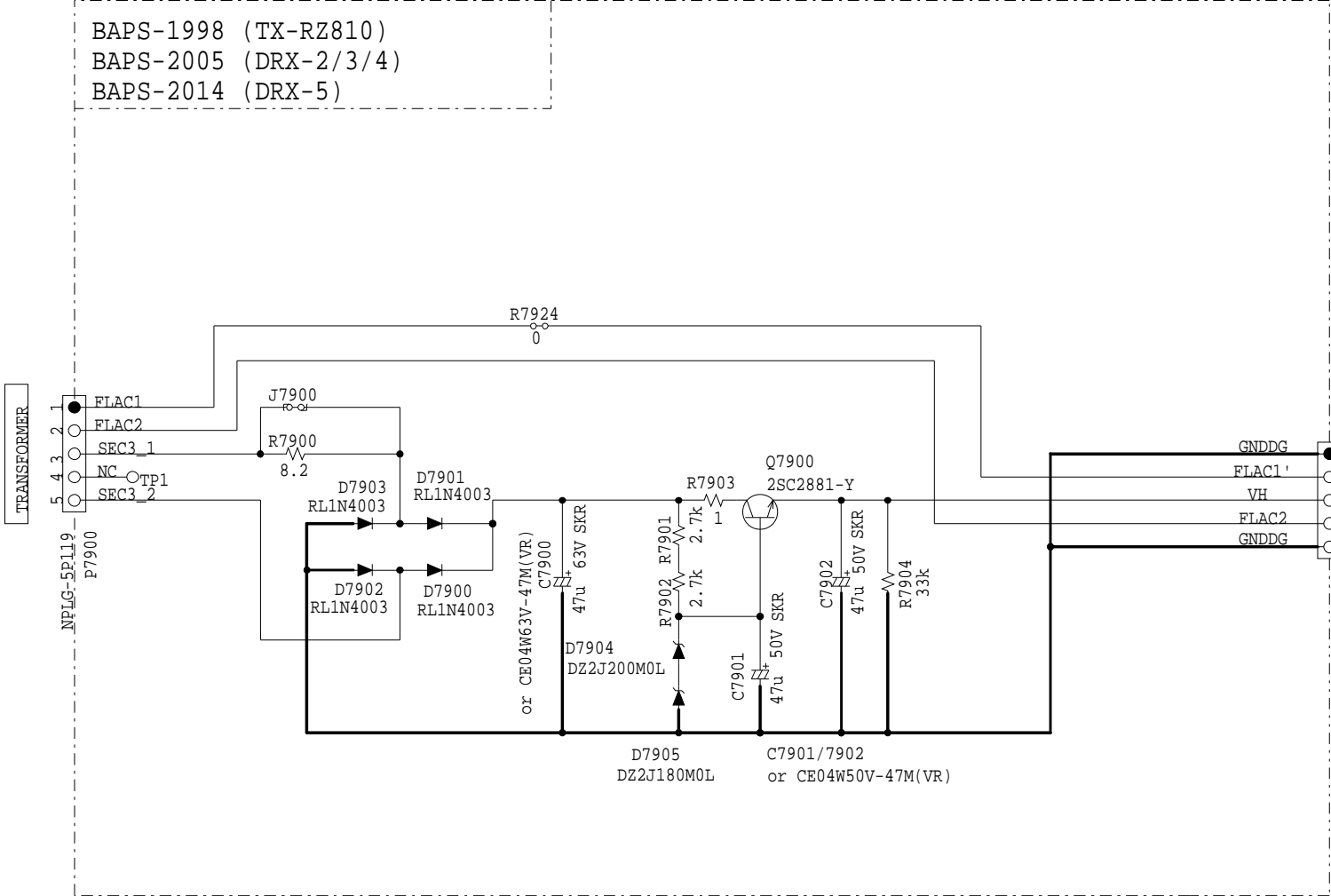

P7990B CHD-1.5-5
 TO BADIS-1990 (PART-8)
 TX-RZ810
 TO BADIS-1999 (PART-8)
 DRX-2/3/4
 TO BADIS-2008 (PART-8)
 DRX-5

Display (Power supply) section

Schematic Diagram

Model No. TX-RZ810, DRX-2/3/4/5 SCHEMATIC DIAGRAM (PART-8)
 DISPLAY(Power supply) SECTION

BAPS-1998 (TX-RZ810)
 BAPS-2005 (DRX-2/3/4)
 BAPS-2014 (DRX-5)

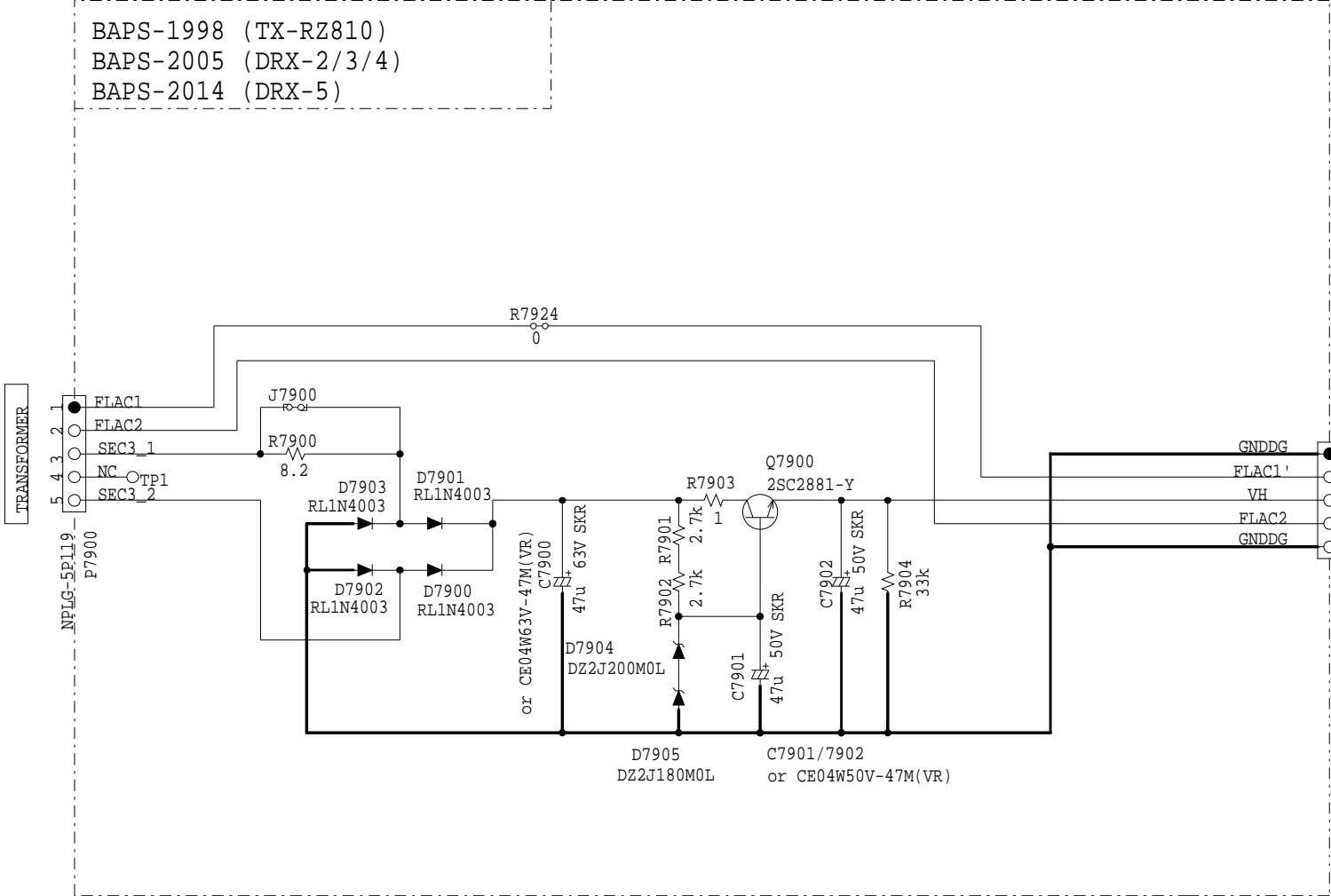

P7990B CHD-1.5-5
 TO BADIS-1990 (PART-8)
 TX-RZ810
 TO BADIS-1999 (PART-8)
 DRX-2/3/4
 TO BADIS-2008 (PART-8)
 DRX-5

MODEL NO. DRX-2/3/4 SCHEMATIC DIAGRAM(PART-8)

SW SECTION

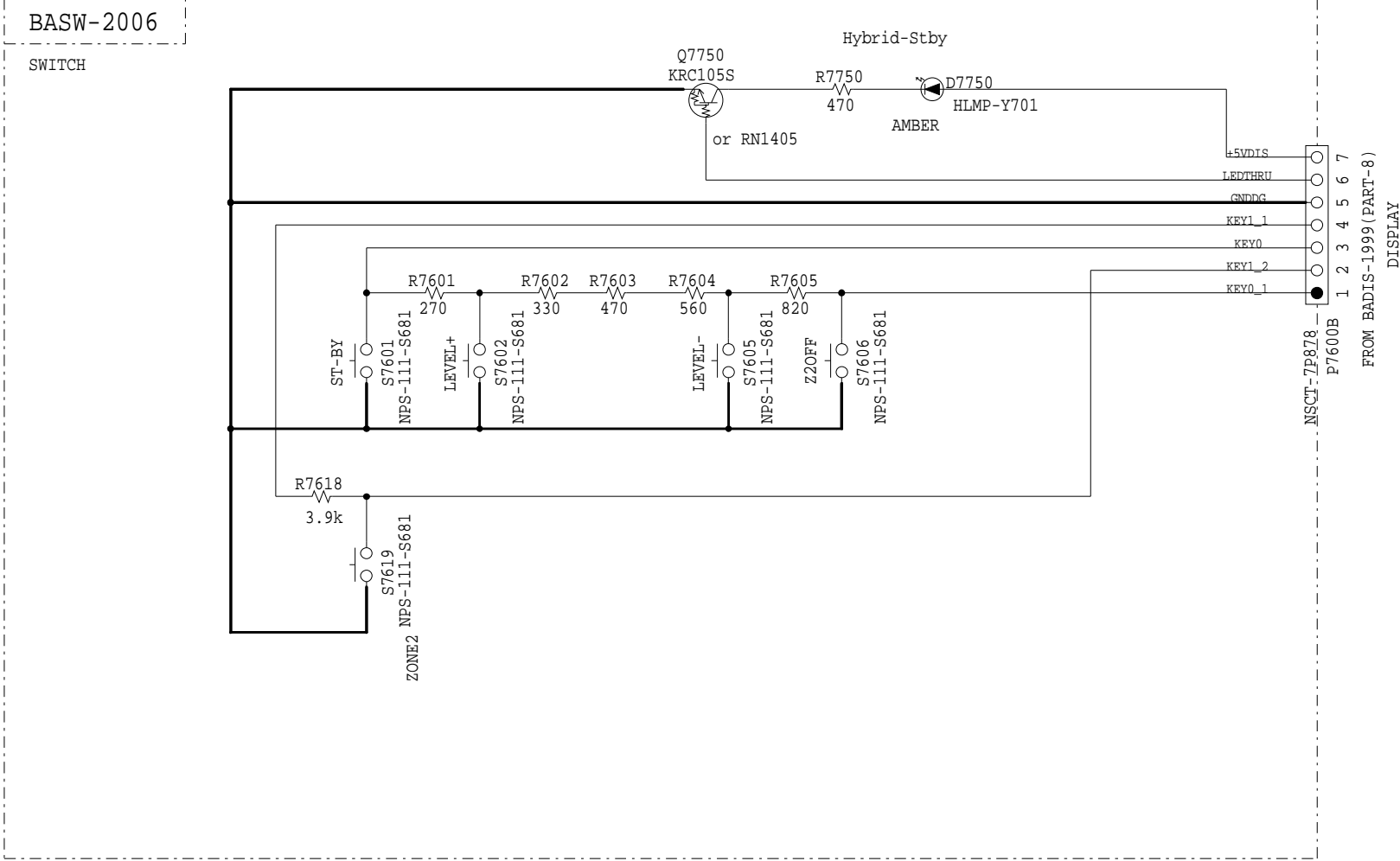

FROM BADIS-1999 (PART-8) DISPLAY

MODEL NO.TX-RZ810 SCHEMATIC DIAGRAM (PART-8) DISPLAY SECTION

BADIS-1990

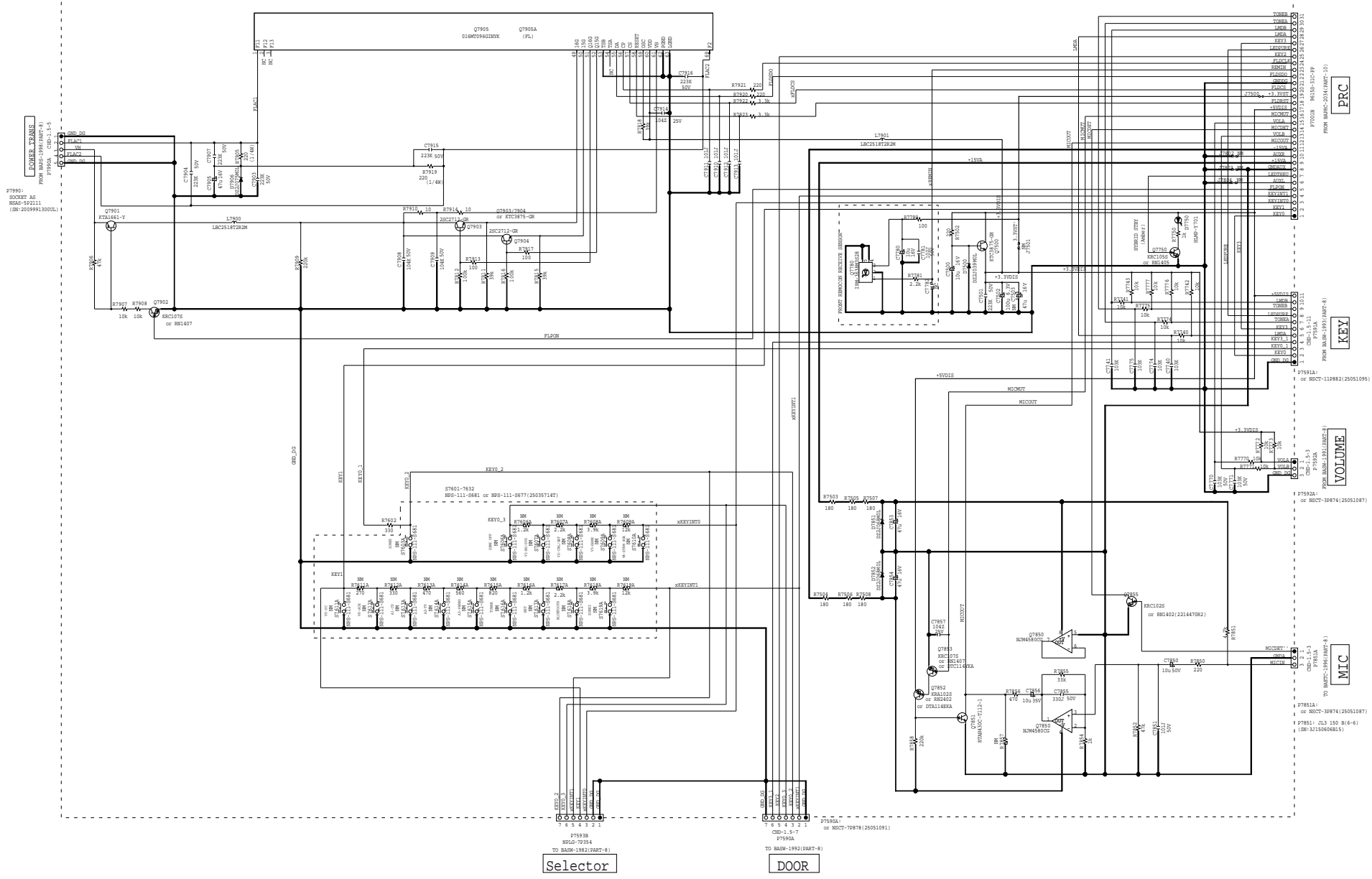

Selector

DOOR

PRC

KEY

VOLUME

MIC

MODEL NO. TX-RZ810

SCHEMATIC DIAGRAM (PART-8)

DISPLAY (VOLUME) SECTION

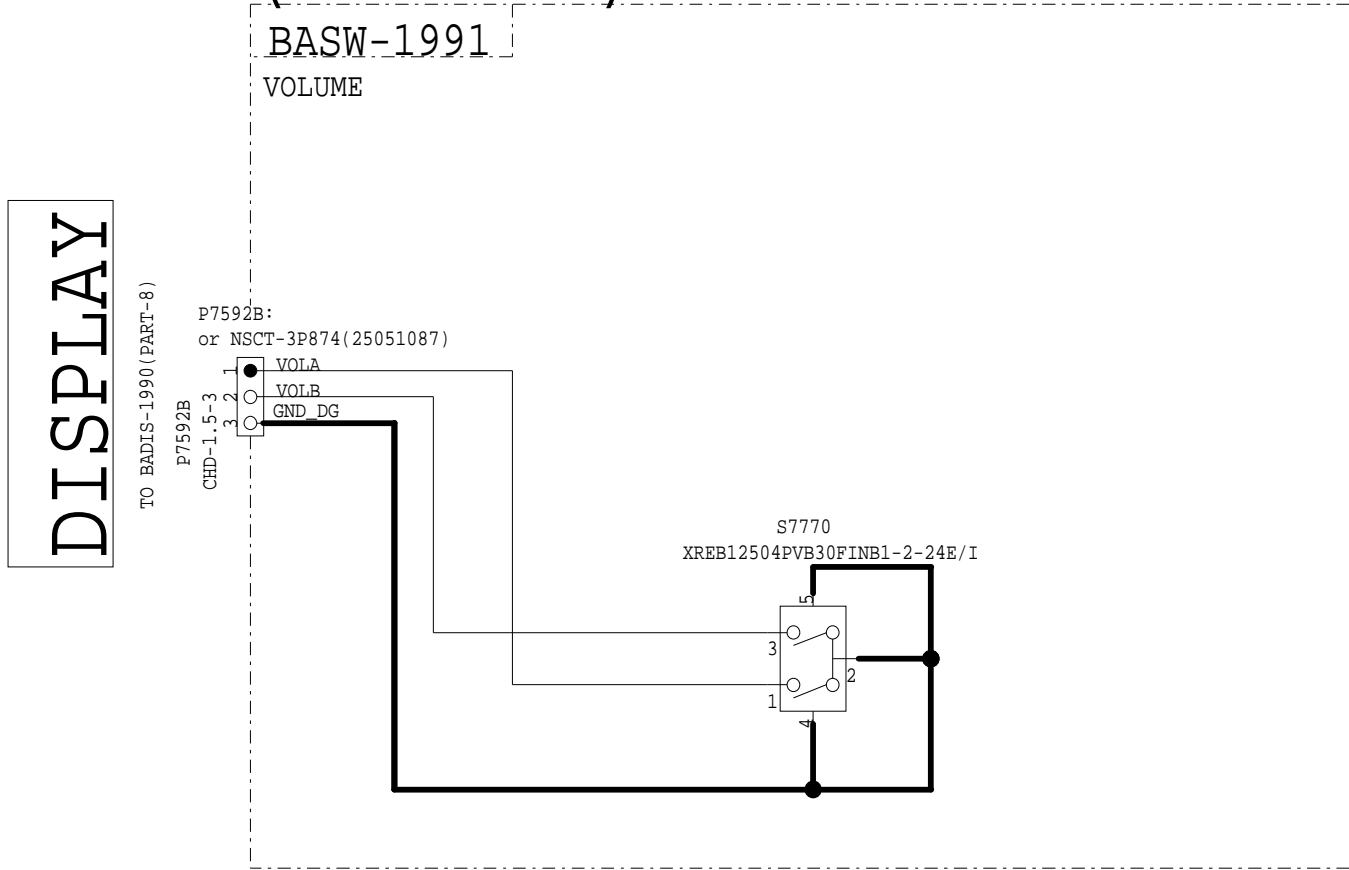

MODEL NO. TX-RZ810 SCHEMATIC DIAGRAM (PART-8) DISPLAY (DOOR) SECTION

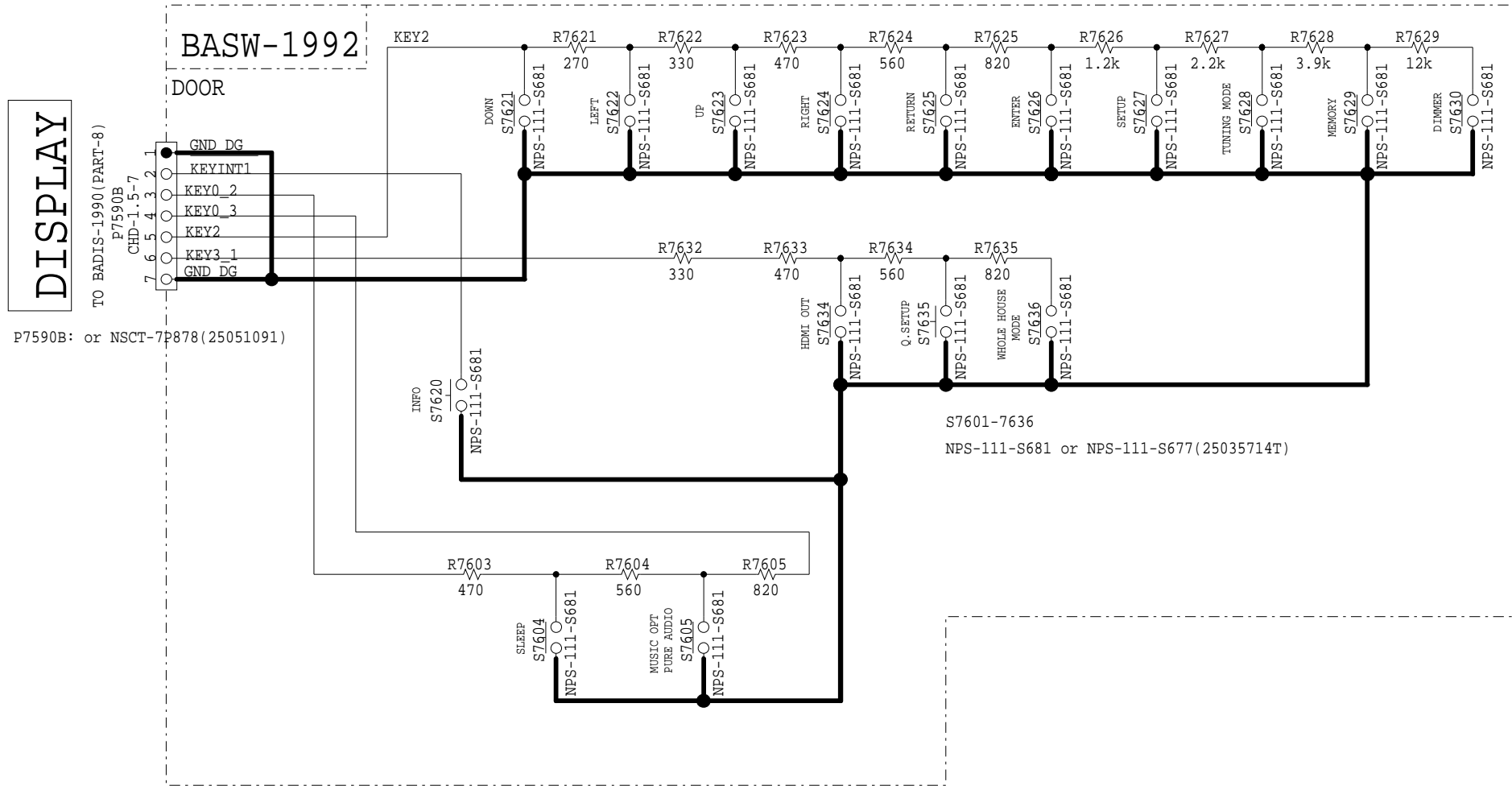

MODEL NO. TX-RZ810

SCHEMATIC DIAGRAM(PART-8) DISPLAY(KEY)SECTION

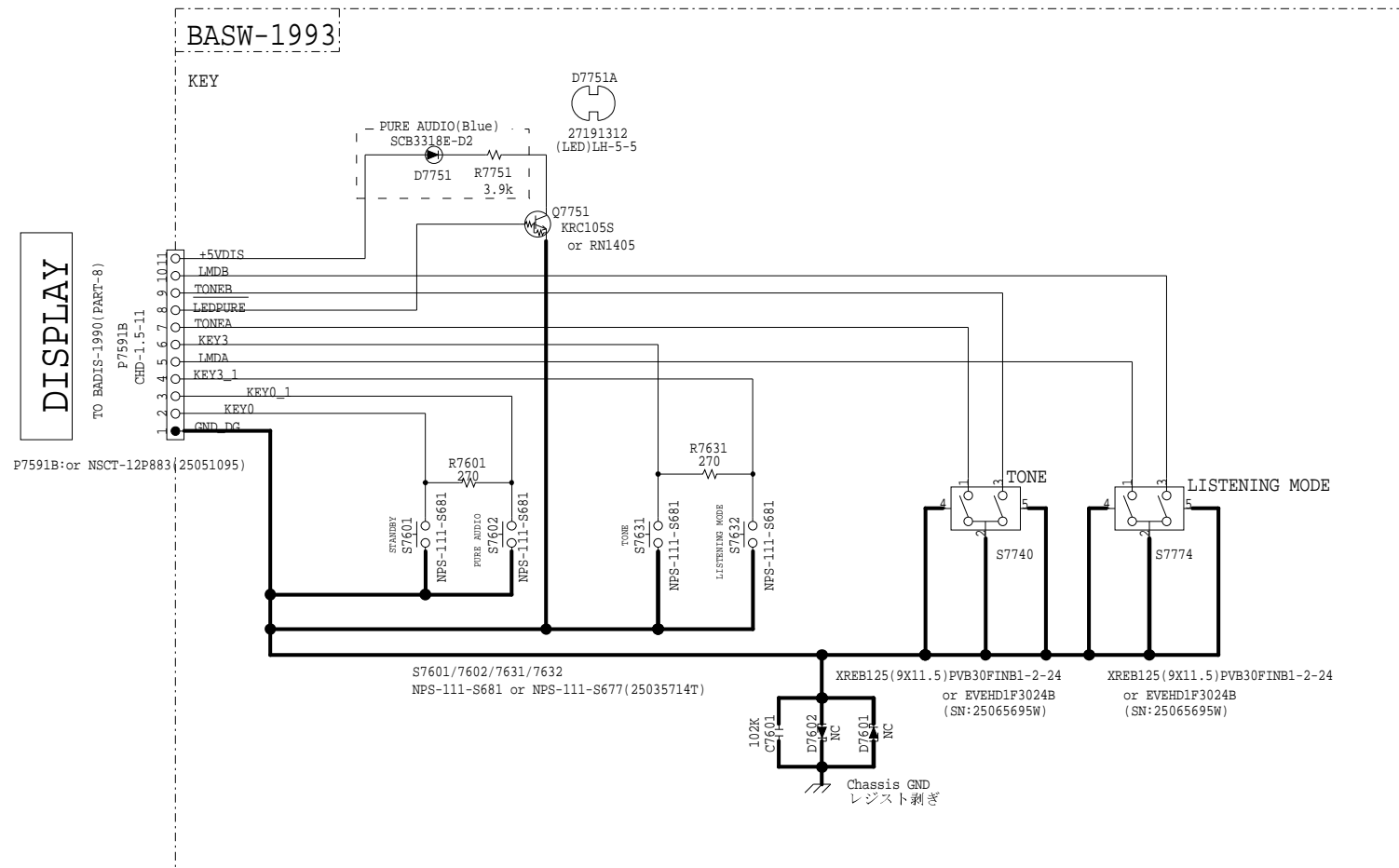

MODEL NO.TX-RZ810

SCHEMATIC DIAGRAM(PART-26) DISPLAY(HEADPHONE)SECTION

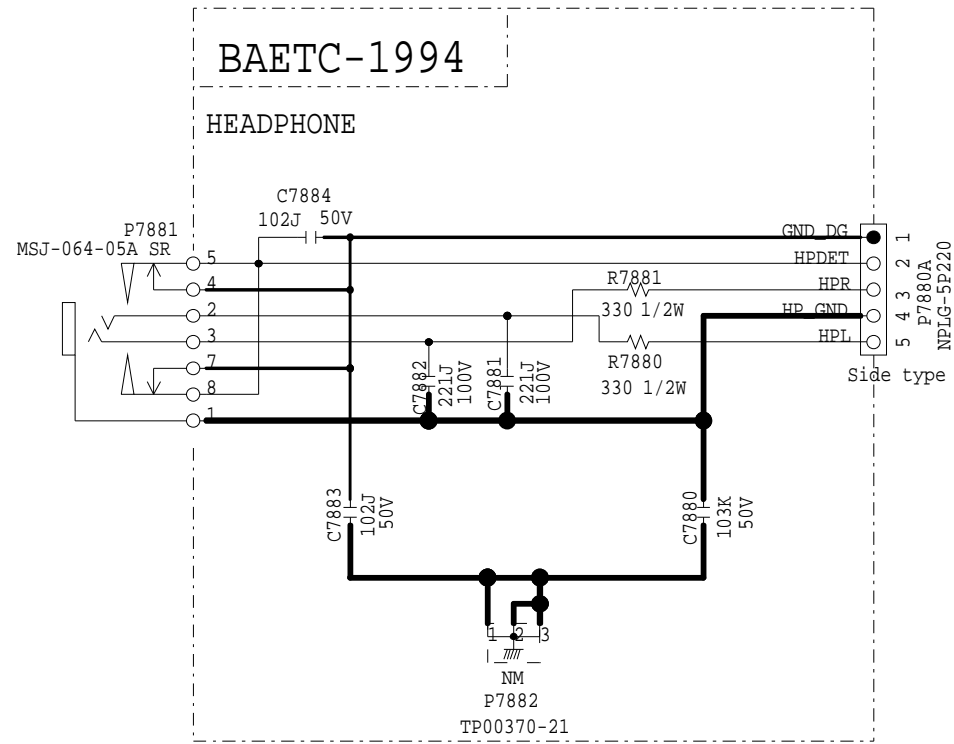

TO TRM

TO BATRM-2023 (PART-7)

MODEL NO.TX-RZ810 SCHEMATIC DIAGRAM(PART-8) DISPLAY(MIC)SECTION

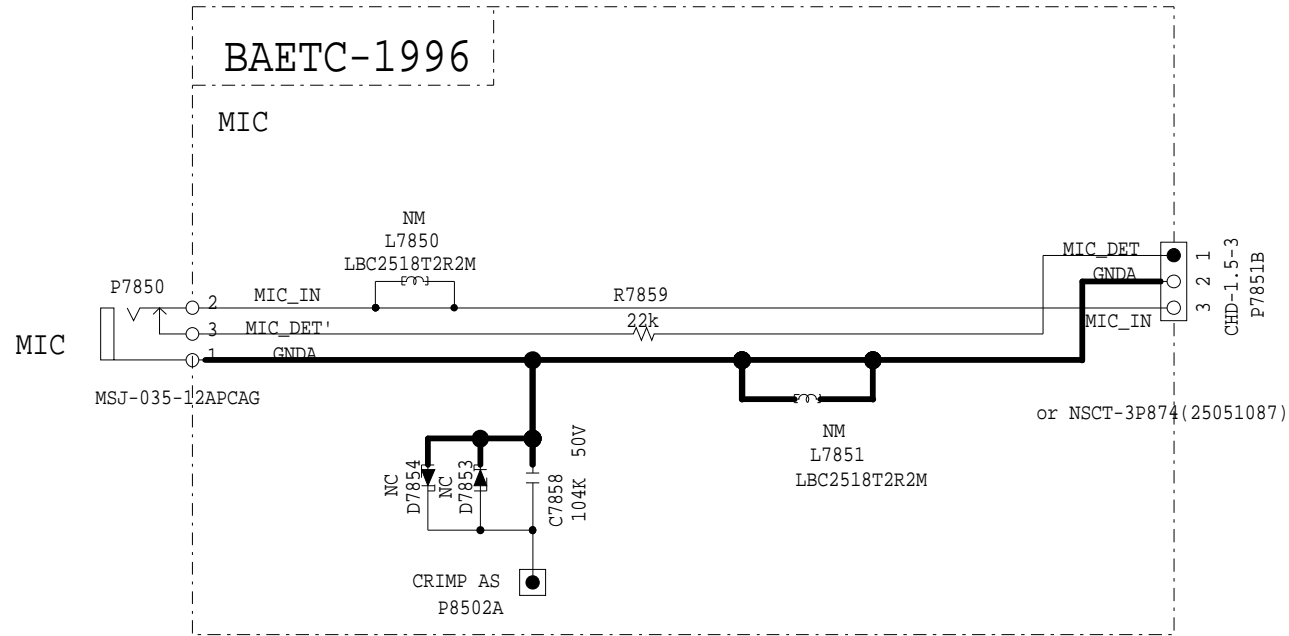

DISPLAY

TO BADIS-1990 (PART-8)

Display (Power supply) section

Schematic Diagram

Model No. TX-RZ810, DRX-5 SCHEMATIC DIAGRAM (PART-8)
 DISPLAY(Power supply) SECTION

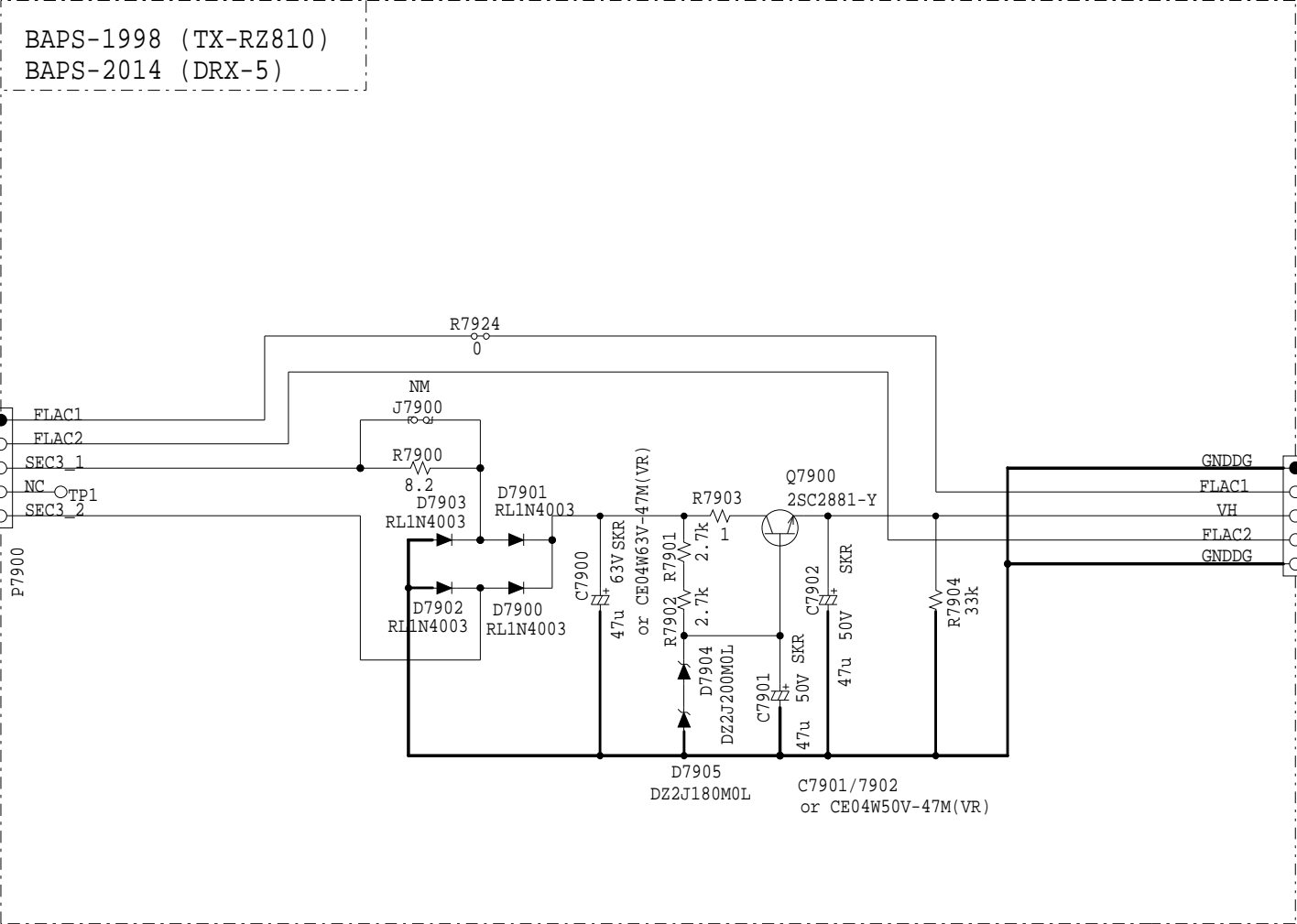

TO BADIS-1990 (PART-8)
 TX-RZ810
 TO BADIS-2008 (PART-8)
 DRX-5

MODEL NO. TX-RZ810 SCHEMATIC DIAGRAM (PART-8) DISPLAY SECTION

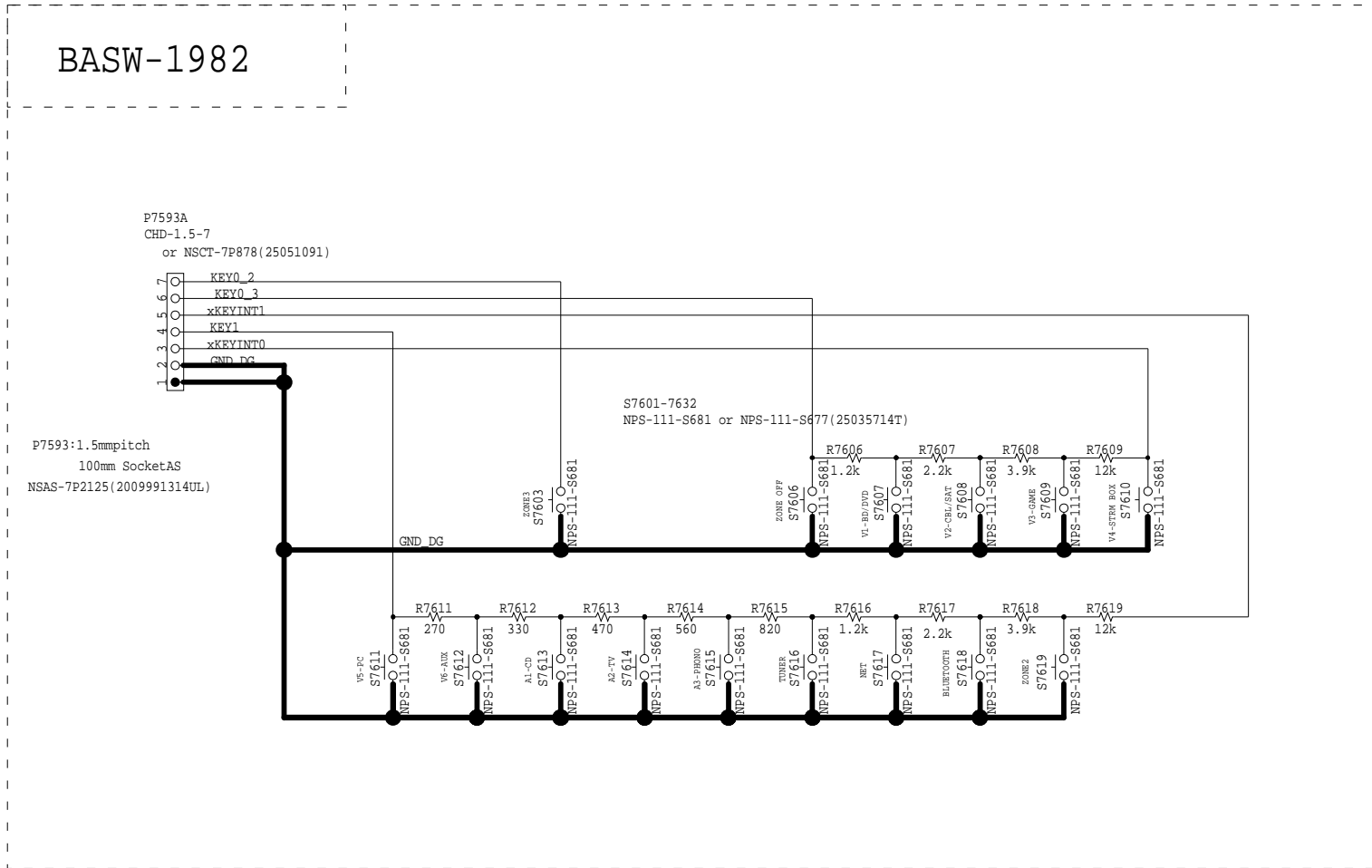

MODEL NO. DRX-5 SCHEMATIC DIAGRAM (PART-8) DISPLAY SECTION

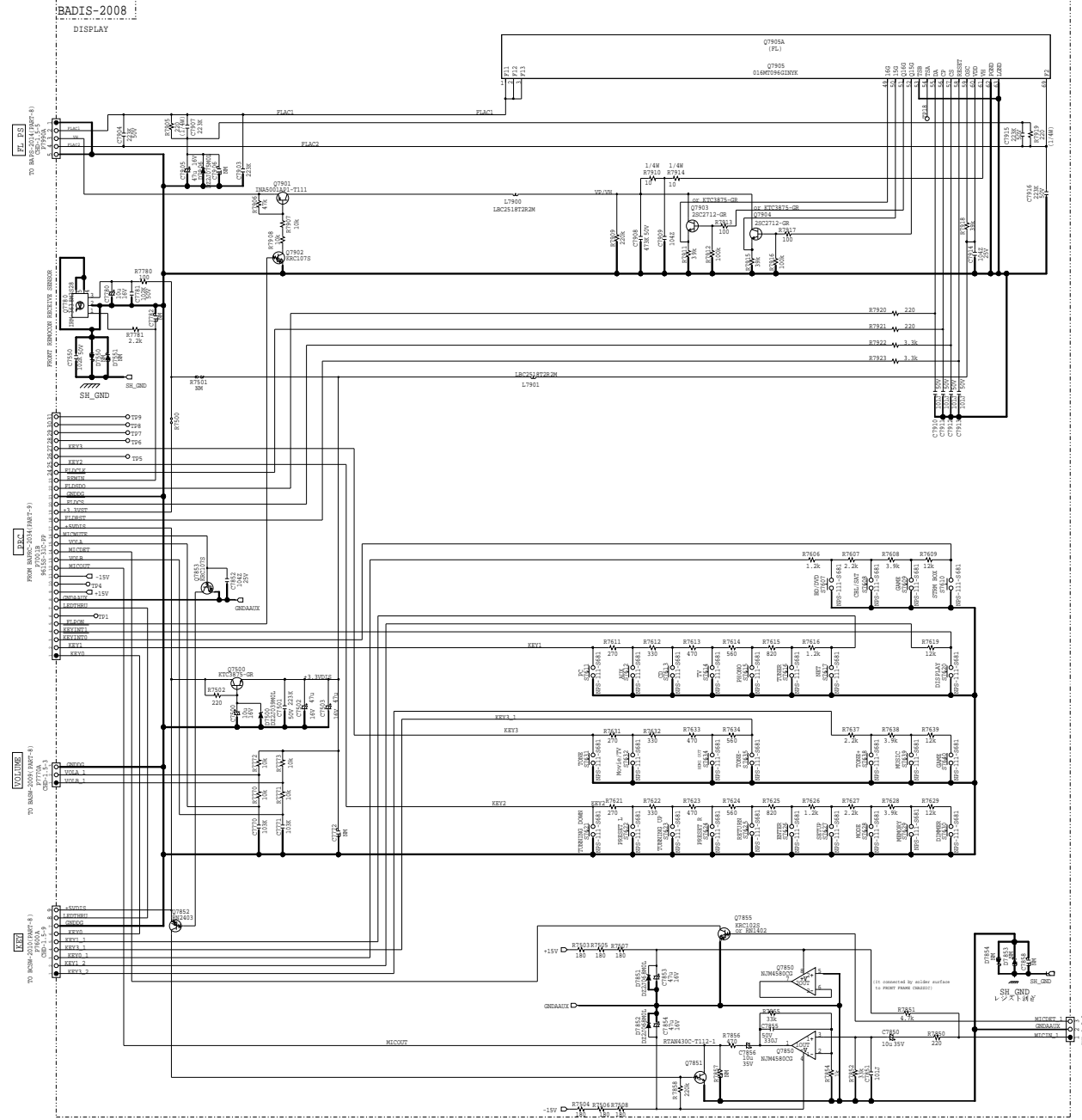

MODEL NO.DRX-5 SCHEMATIC DIAGRAM
DISPLAY(VOLUME) SECTION (PART-8)

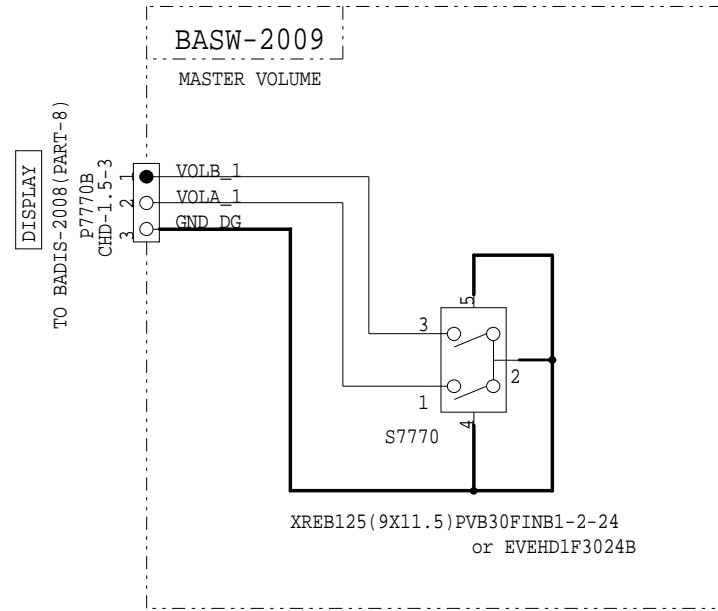

MODEL NO. DRX-5 SCHEMATIC DIAGRAM(PART-8) DISPLAY(KEY)SECTION

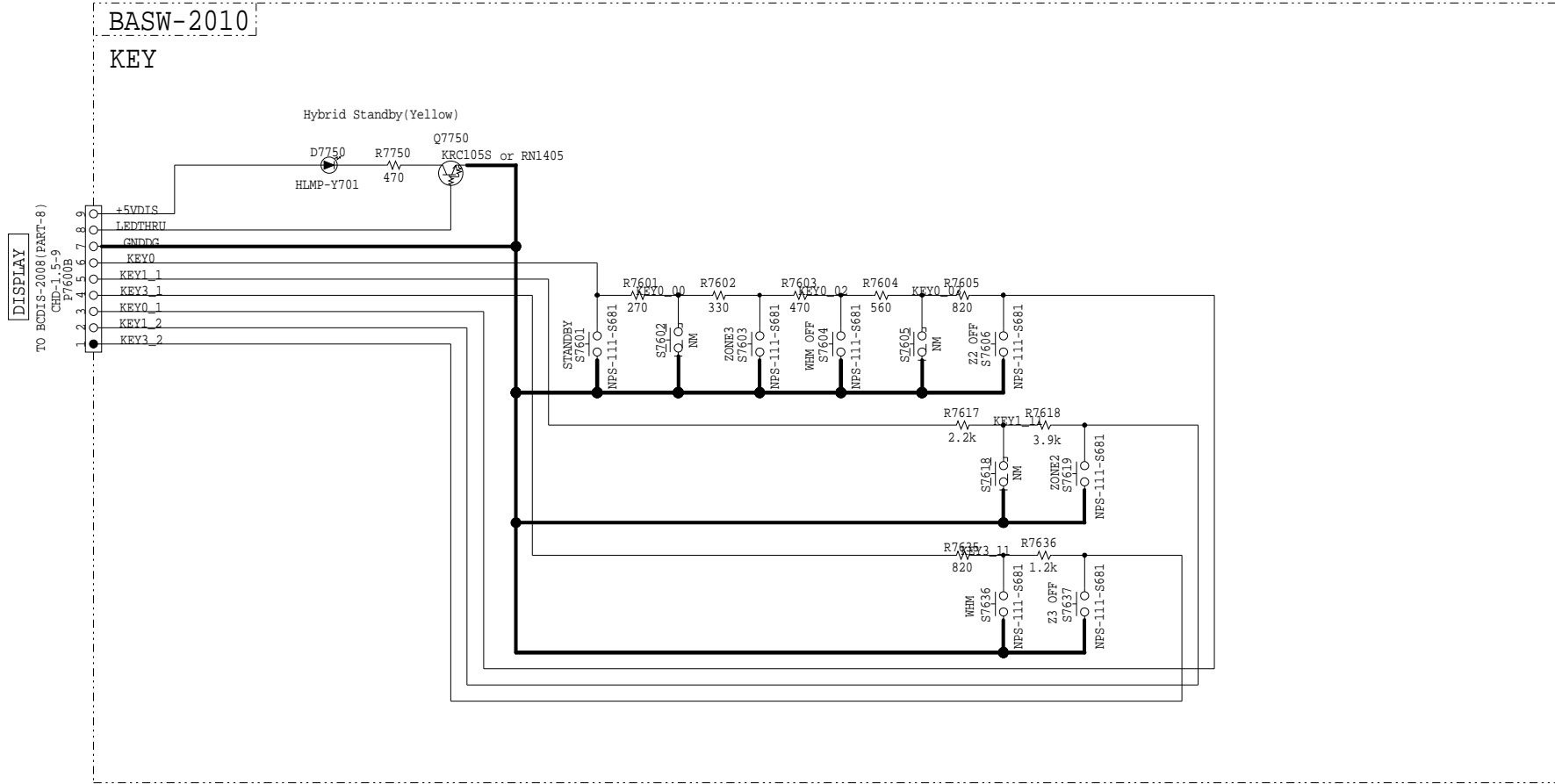

MODEL NO.DRX-5

SCHEMATIC DIAGRAM(PART-8)

DISPLAY (HEADPHONE) SECTION

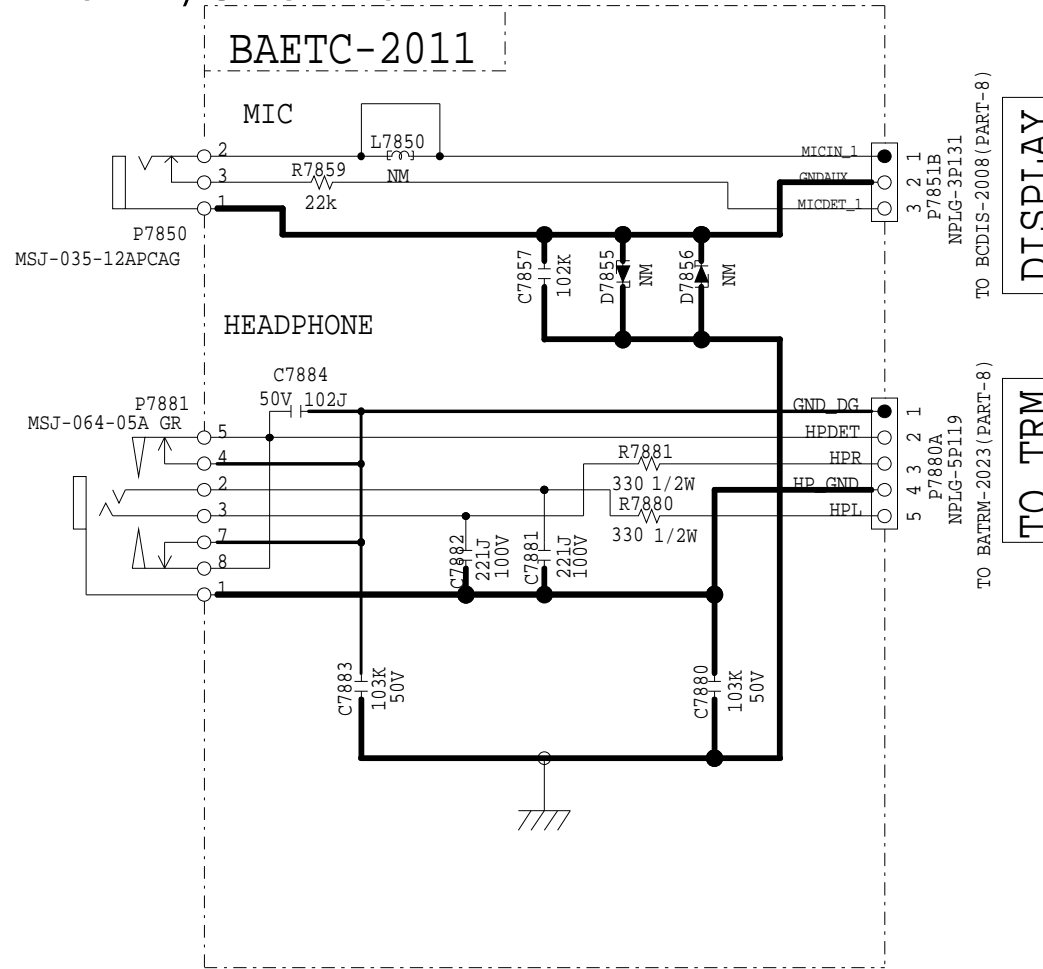

MODEL No. TX-NR555/656/757, TX-RZ610/710, HT-R695, DRX-2/3/4 SCHEMATIC DIAGRAM (PART-9)

DAC FILTER SECTION

商品価額表に照らしアルミ電解Cは全てJ-TS P品
部品定格または定格電力表記無き抵抗は全て1/10Wチップ品

<- REAR SIDE

P8003A IMSA-9850S-30

to PRC2034 (PART10)

P8002A IMSA-9850S-30

BADG-1985(1/1)
BADG-2001(1/1)
BADG-2017(1/1)

DIS1983	DIS1999	DIS2015
T5 : [A]=D, [B]=M	D2 : [A]=D, [B]=M	V8 : [A]=D/J, [B]=M
T6 : [C]=D/3, [D]=M, [E]=MMB	D3 : [C]=D/3, [D]=M	L3 : [C]=D
T6 : [C]=D	D4 : [B]=D, [F]=M	V11 : [E]=D/J, [F]=M
T7 : [F]=D, [G]=M, [H]=MMB	L3 : [G]=M	

DESTINATION LIST (FILTER)

	7ch w/ VLSC T5/T6/T7/T2 D2/D3/D4	7ch w/o VLSC L1/V11/L3	5ch w/o VLSC V8
R1841/1842	NM	47 ohm	47 ohm
R1881/1882	47 ohm	0 ohm	0 ohm
R1883-1886	47 ohm	47 ohm	47 ohm
R1887/1888	47 ohm	47 ohm	NM
Q152*/154*			
R166*/168*/170*/172*/ 174*/176*/178*/180*/ 182*/186*	MOUNT	NM	NM
C158*/164*			
Rxxxx7/xxxx8/ Cxxxx7/xxxx8	MOUNT	MOUNT	NM
R1501/1502/1521/1522/ 1541/1542/1561/1562/ 1581/1582/1601/1602/ C1501/1502/ 1521/1522/ 1541/1542/1561/1562	820 1.5k 4.7k 681J 122J 333J	3.3k 0 3.3k NM 392J 681J	3.3k 0 3.3k NM 392J 681J

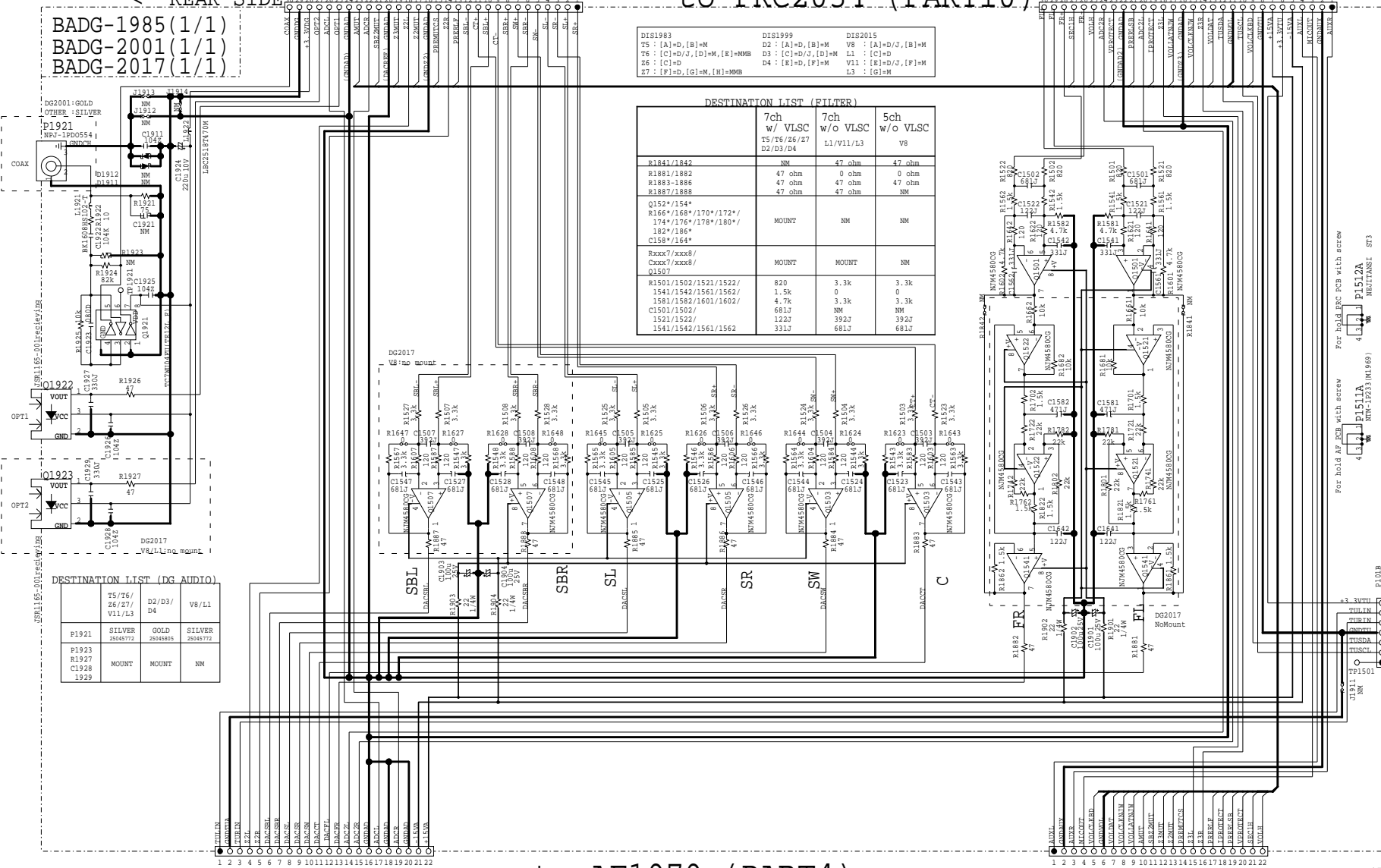

DESTINATION LIST (DC AUDIO)

	T5/T6/ 26/27/ V11/L3	D2/D3/ D4	V8/L1
P1921	SILVER 25045772	GOLD 20448005	SILVER 25044772
P1923			
P1927	MOUNT	MOUNT	NM
P1928			
1929			

For hold PCB with screw
P1511A
P1512A
P1513A
P1514A
P1515A
P1516A
P1517A
P1518A
P1519A
P1520A
P1521A
P1522A
P1523A
P1524A
P1525A
P1526A
P1527A
P1528A
P1529A
P1530A
P1531A
P1532A
P1533A
P1534A
P1535A
P1536A
P1537A
P1538A
P1539A
P1540A
P1541A
P1542A
P1543A
P1544A
P1545A
P1546A
P1547A
P1548A
P1549A
P1550A
P1551A
P1552A
P1553A
P1554A
P1555A
P1556A
P1557A
P1558A
P1559A
P1560A
P1561A
P1562A
P1563A
P1564A
P1565A
P1566A
P1567A
P1568A
P1569A
P1570A
P1571A
P1572A
P1573A
P1574A
P1575A
P1576A
P1577A
P1578A
P1579A
P1580A
P1581A
P1582A
P1583A
P1584A
P1585A
P1586A
P1587A
P1588A
P1589A
P1590A
P1591A
P1592A
P1593A
P1594A
P1595A
P1596A
P1597A
P1598A
P1599A
P1600A
P1601A
P1602A
P1603A
P1604A
P1605A
P1606A
P1607A
P1608A
P1609A
P1610A
P1611A
P1612A
P1613A
P1614A
P1615A
P1616A
P1617A
P1618A
P1619A
P1620A
P1621A
P1622A
P1623A
P1624A
P1625A
P1626A
P1627A
P1628A
P1629A
P1630A
P1631A
P1632A
P1633A
P1634A
P1635A
P1636A
P1637A
P1638A
P1639A
P1640A
P1641A
P1642A
P1643A
P1644A
P1645A
P1646A
P1647A
P1648A
P1649A
P1650A
P1651A
P1652A
P1653A
P1654A
P1655A
P1656A
P1657A
P1658A
P1659A
P1660A
P1661A
P1662A
P1663A
P1664A
P1665A
P1666A
P1667A
P1668A
P1669A
P1670A
P1671A
P1672A
P1673A
P1674A
P1675A
P1676A
P1677A
P1678A
P1679A
P1680A
P1681A
P1682A
P1683A
P1684A
P1685A
P1686A
P1687A
P1688A
P1689A
P1690A
P1691A
P1692A
P1693A
P1694A
P1695A
P1696A
P1697A
P1698A
P1699A
P1700A
P1701A
P1702A
P1703A
P1704A
P1705A
P1706A
P1707A
P1708A
P1709A
P1710A
P1711A
P1712A
P1713A
P1714A
P1715A
P1716A
P1717A
P1718A
P1719A
P1720A
P1721A
P1722A
P1723A
P1724A
P1725A
P1726A
P1727A
P1728A
P1729A
P1730A
P1731A
P1732A
P1733A
P1734A
P1735A
P1736A
P1737A
P1738A
P1739A
P1740A
P1741A
P1742A
P1743A
P1744A
P1745A
P1746A
P1747A
P1748A
P1749A
P1750A
P1751A
P1752A
P1753A
P1754A
P1755A
P1756A
P1757A
P1758A
P1759A
P1760A
P1761A
P1762A
P1763A
P1764A
P1765A
P1766A
P1767A
P1768A
P1769A
P1770A
P1771A
P1772A
P1773A
P1774A
P1775A
P1776A
P1777A
P1778A
P1779A
P1780A
P1781A
P1782A
P1783A
P1784A
P1785A
P1786A
P1787A
P1788A
P1789A
P1790A
P1791A
P1792A
P1793A
P1794A
P1795A
P1796A
P1797A
P1798A
P1799A
P1800A
P1801A
P1802A
P1803A
P1804A
P1805A
P1806A
P1807A
P1808A
P1809A
P1810A
P1811A
P1812A
P1813A
P1814A
P1815A
P1816A
P1817A
P1818A
P1819A
P1820A
P1821A
P1822A
P1823A
P1824A
P1825A
P1826A
P1827A
P1828A
P1829A
P1830A
P1831A
P1832A
P1833A
P1834A
P1835A
P1836A
P1837A
P1838A
P1839A
P1840A
P1841A
P1842A
P1843A
P1844A
P1845A
P1846A
P1847A
P1848A
P1849A
P1850A
P1851A
P1852A
P1853A
P1854A
P1855A
P1856A
P1857A
P1858A
P1859A
P1860A
P1861A
P1862A
P1863A
P1864A
P1865A
P1866A
P1867A
P1868A
P1869A
P1870A
P1871A
P1872A
P1873A
P1874A
P1875A
P1876A
P1877A
P1878A
P1879A
P1880A
P1881A
P1882A
P1883A
P1884A
P1885A
P1886A
P1887A
P1888A
P1889A
P1890A
P1891A
P1892A
P1893A
P1894A
P1895A
P1896A
P1897A
P1898A
P1899A
P1900A
P1901A
P1902A
P1903A
P1904A
P1905A
P1906A
P1907A
P1908A
P1909A
P1910A
P1911A
P1912A
P1913A
P1914A
P1915A
P1916A
P1917A
P1918A
P1919A
P1920A
P1921A
P1922A
P1923A
P1924A
P1925A
P1926A
P1927A
P1928A
P1929A
P1930A
P1931A
P1932A
P1933A
P1934A
P1935A
P1936A
P1937A
P1938A
P1939A
P1940A
P1941A
P1942A
P1943A
P1944A
P1945A
P1946A
P1947A
P1948A
P1949A
P1950A
P1951A
P1952A
P1953A
P1954A
P1955A
P1956A
P1957A
P1958A
P1959A
P1960A
P1961A
P1962A
P1963A
P1964A
P1965A
P1966A
P1967A
P1968A
P1969A
P1970A
P1971A
P1972A
P1973A
P1974A
P1975A
P1976A
P1977A
P1978A
P1979A
P1980A
P1981A
P1982A
P1983A
P1984A
P1985A
P1986A
P1987A
P1988A
P1989A
P1990A
P1991A
P1992A
P1993A
P1994A
P1995A
P1996A
P1997A
P1998A
P1999A
P2000A
P2001A
P2002A
P2003A
P2004A
P2005A
P2006A
P2007A
P2008A
P2009A
P2010A
P2011A
P2012A
P2013A
P2014A
P2015A
P2016A
P2017A
P2018A
P2019A
P2020A
P2021A
P2022A

P1501A IMSA-9142B-22A

to AF1979 (PART4)

P1502A IMSA-9142B-22A

FILTER : 1500 - 1999

<- REAR SIDE

to RF1987/1995/2003/2012/2019
(PART11)

MODEL No. TX-RZ810, DRX-5 SCHEMATIC DIAGRAM (PART-9)
 DAC FILTER (VLSC) SECTION

部品種類未記番号アルミ電解Cは全てE1S1D品
 部品定格または定格値が表記無き抵抗は全て1/10Wチップ品

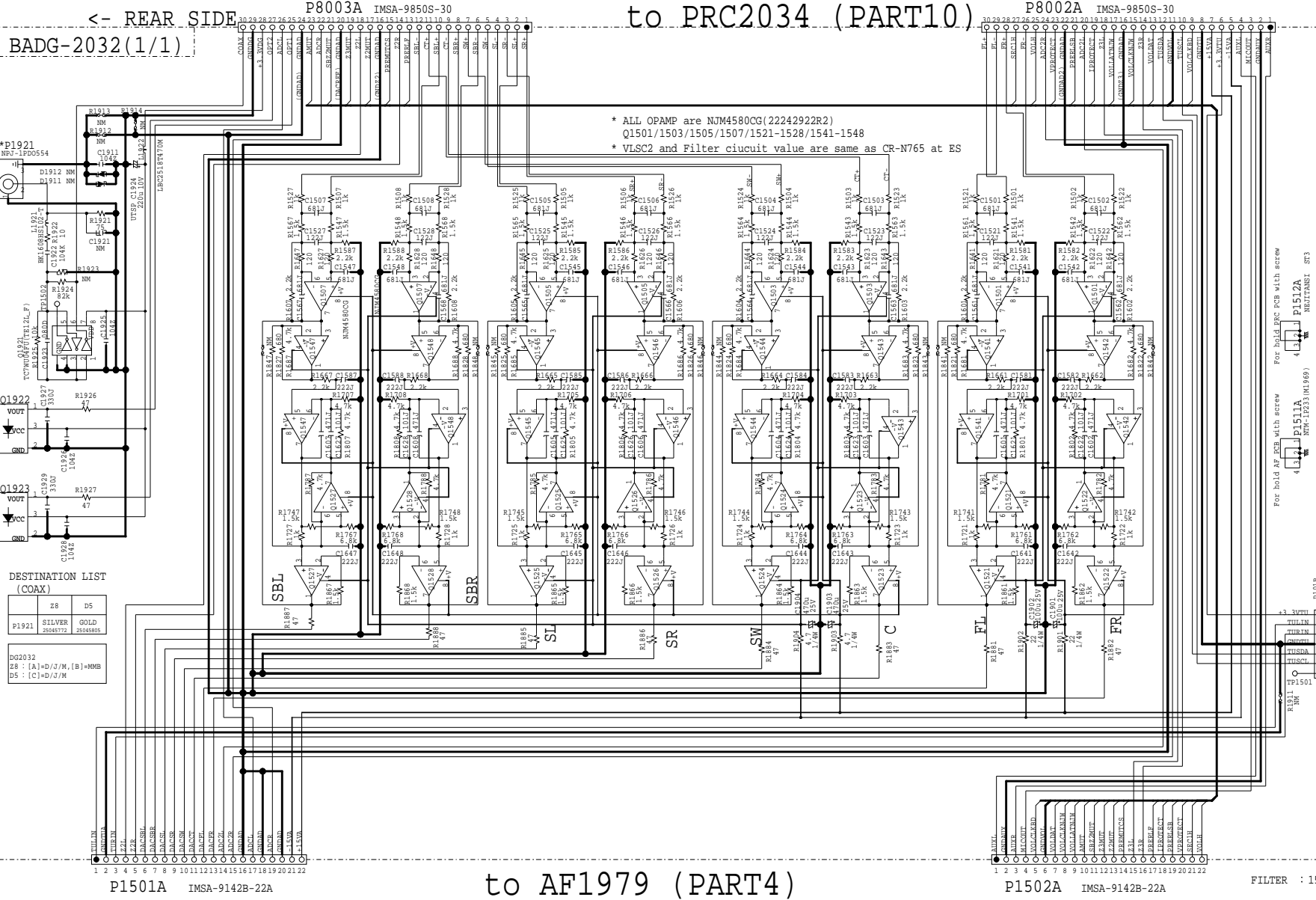

P1501A IMSA-9142B-22A

to AF1979 (PART4)

P1502A IMSA-9142B-22A

FILTER : 1500 - 1999

to RF1987/1995/2003/2012/2019
 (PART11)

For hold AF PCB with screw
 P1511A
 RW-1P233 (M1969)

For hold PCB with screw
 P1512A
 RW1511

MODEL NO. TX-NR555/656/757, TX-RZ610/710/810, HT-R695
DRX-2/3/4/5.

SCHEMATIC DIAGRAM (PART-10) MPU SECTION

BAPRC-2034 (1/11)

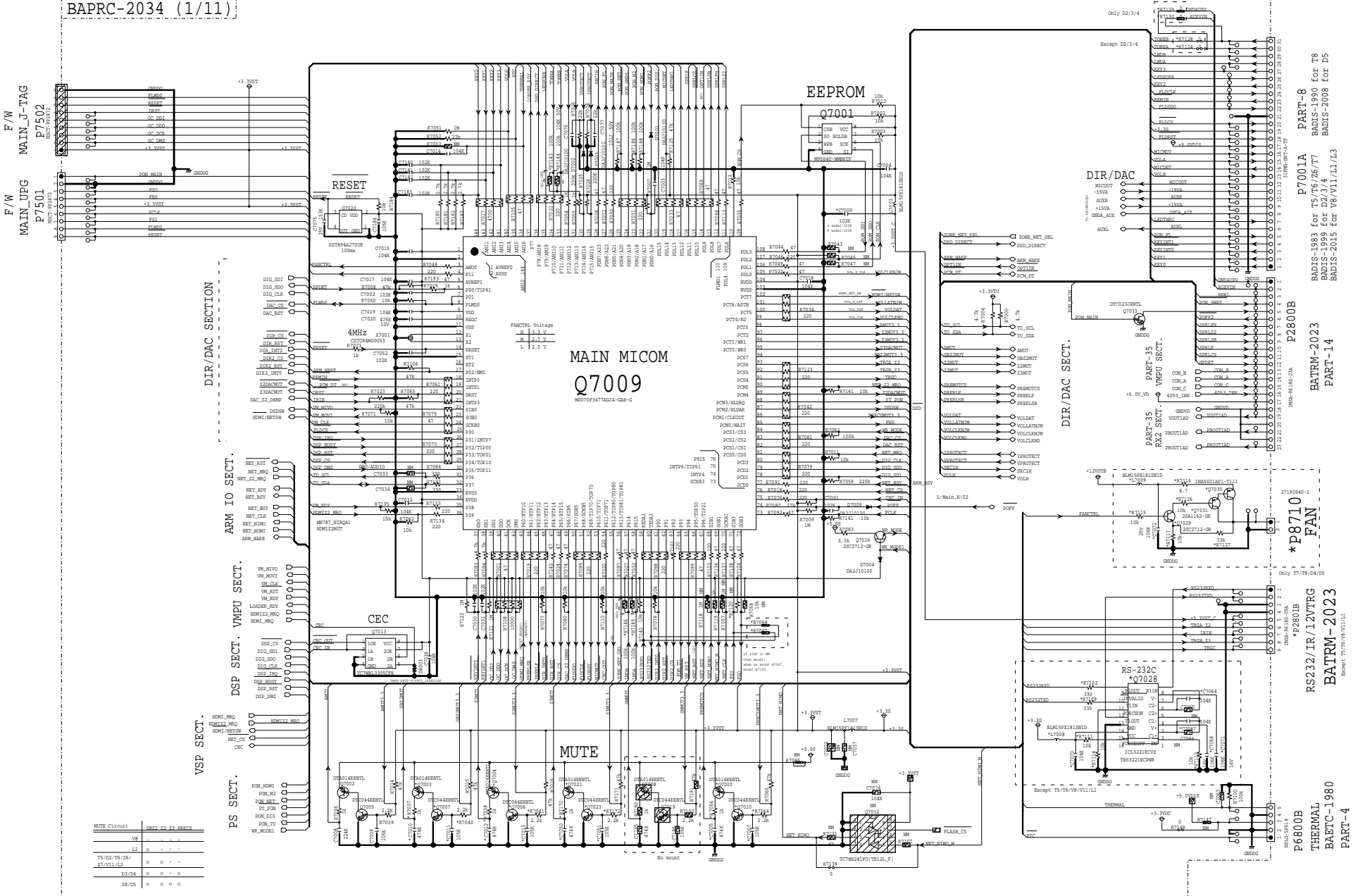

MUTE Circuit

VR	SW2	P1	P2	SW2CN
V1	0	0	0	0
T5/D2/T6/26	0	0	0	0
27/31/11/13	0	0	0	0
33/34	0	0	0	0
28/29	0	0	0	0

- PART-8
BADIS-1993 for T5/T6/26/T7
BADIS-1999 for D2/3/4
BADIS-2008 for D5
- PART-14
BATRM-2023
- PART-35
VMPU SECT.
- PART-35
VMPU SECT.
- *P8710
FAN
- PART-4
P8600B
THERMAL
BATC-1980
- RS232C/IR/12VTRG
BATRM-2023

MODEL NO. TX-NR555/656/757, TX-RZ610/710/810, HT-R695
DRX-2/3/4/5

SCHEMATIC DIAGRAM (PART-10) VMPU SECTION

BAPRC-2034 (2/11)

BAHDM-2042 PART-14

HDbaseT

*P8701A

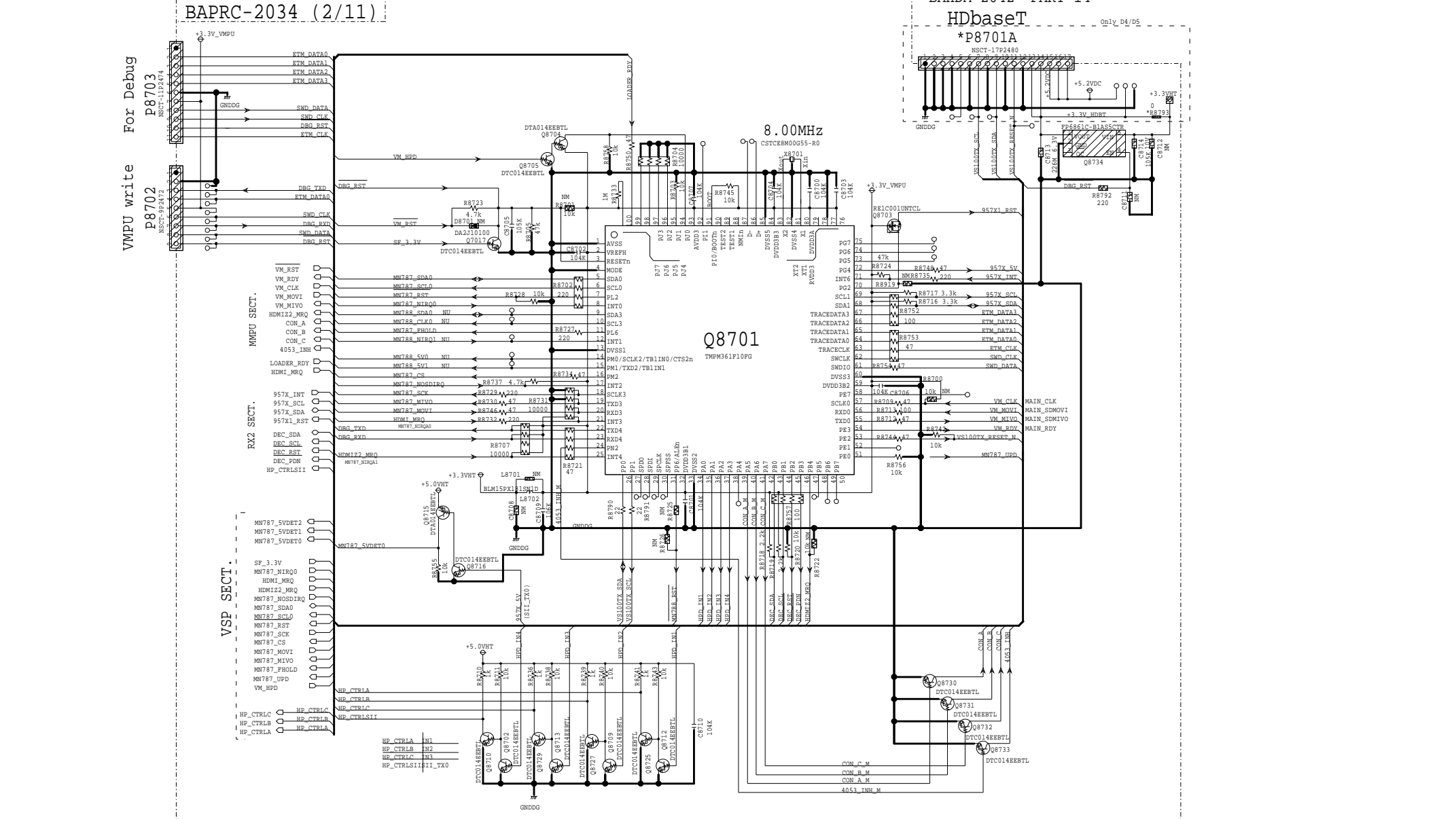
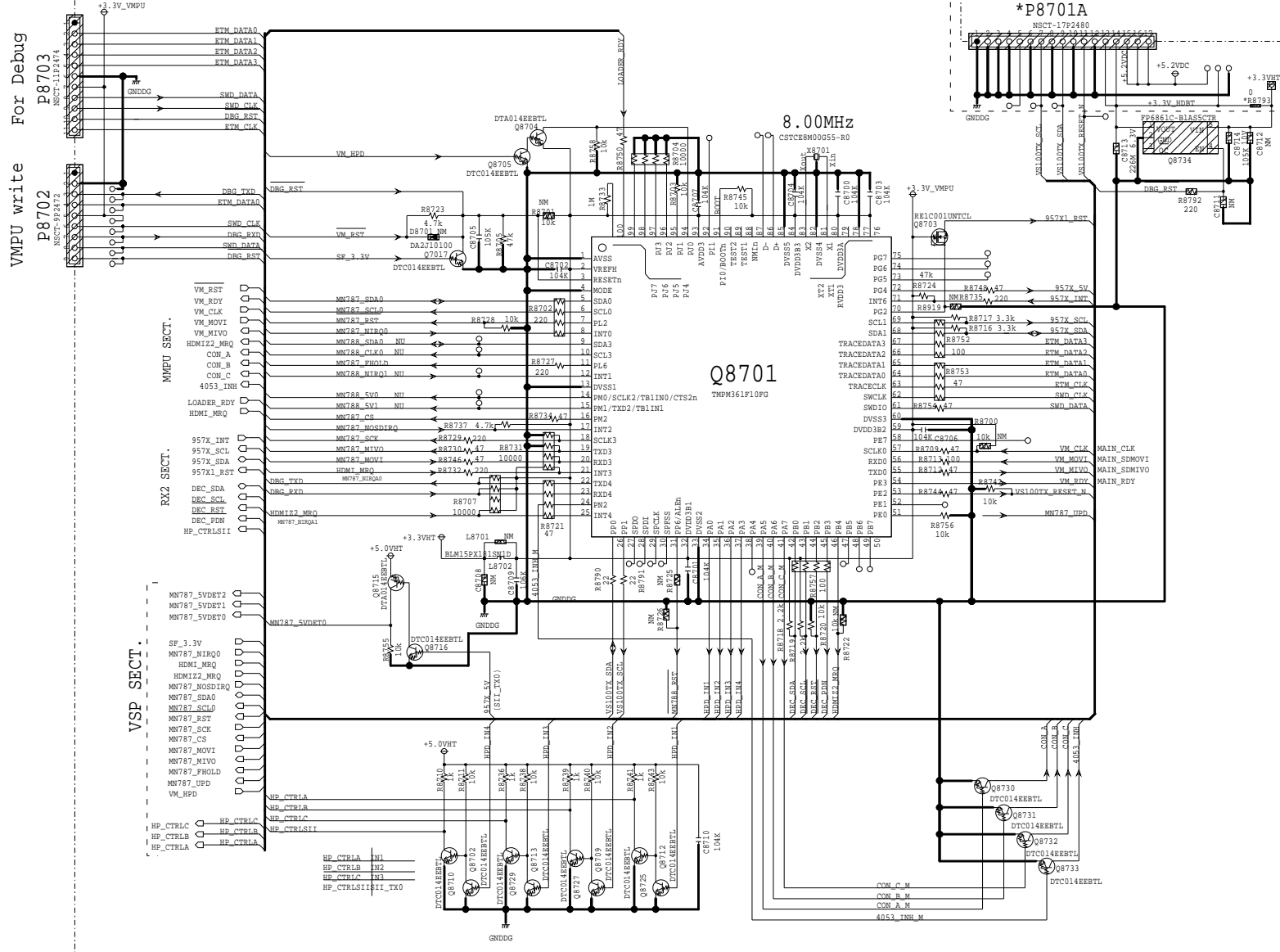

MODEL NO. TX-NR555/656/757, TX-RZ610/710/810, HT-R695
DRX-2/3/4/5

SCHEMATIC DIAGRAM (PART-10) VSP SECTION

BAPRC-2034 (3/11)

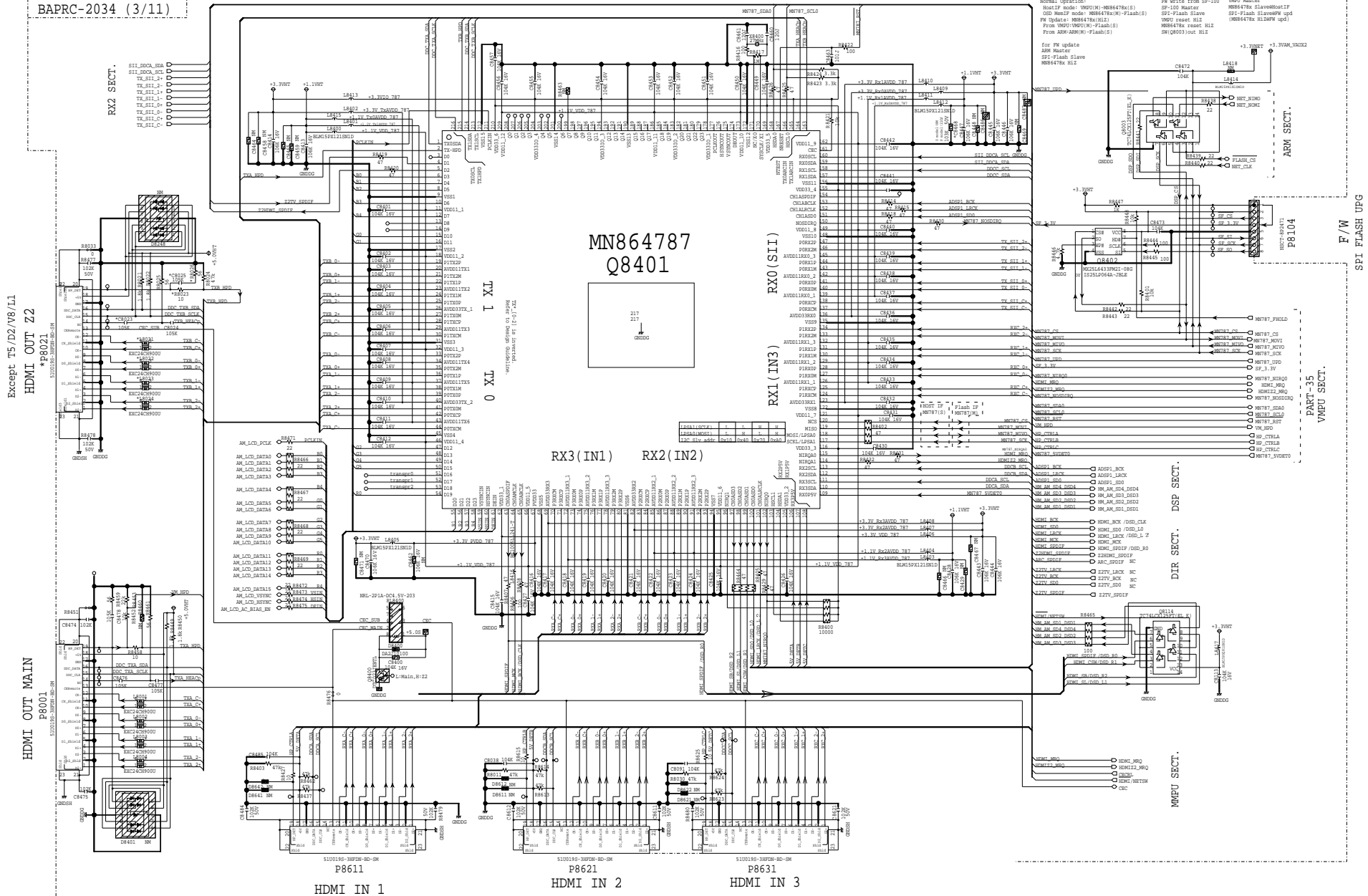

MODEL NO. TX-NR555/656/757, TX-RZ610/710/810, HT-R695
DRX-2/3/4/5

SCHEMATIC DIAGRAM (PART-10) HDMI RX2 SECTION

BAPRC-2034 (4/11)

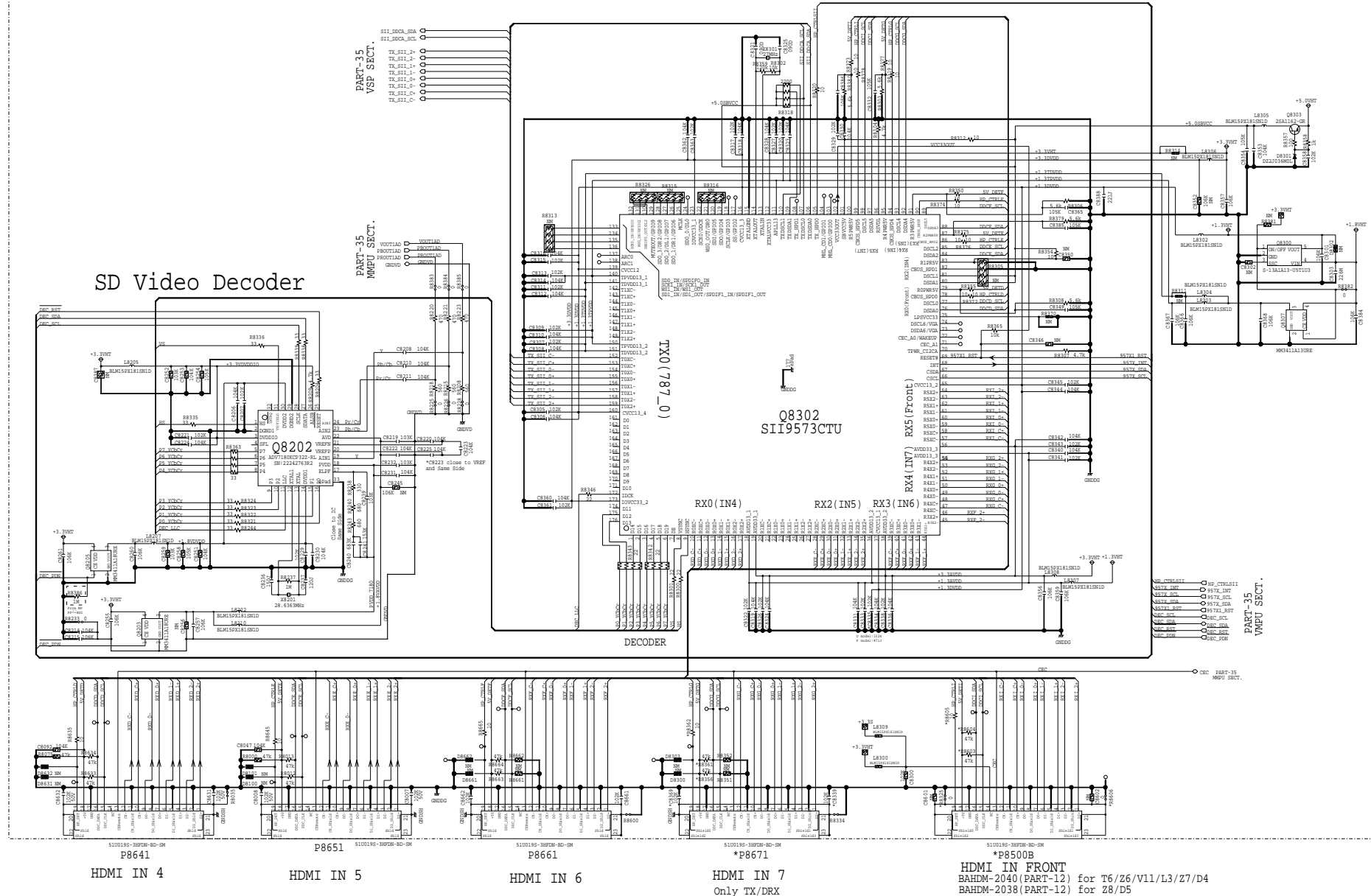

SD Video Decoder

TXO(787_0)

Q8302 SII9573CTU

RX5 (Front)

RX4 (IN7)

RX0 (IN4)

RX2 (IN5)

RX3 (IN6)

DECODER

HDMI IN 4

HDMI IN 5

HDMI IN 6

HDMI IN 7

Only TX/DRX

HDMI IN FRONT

BAHDM-2040 (PART-12) for T6/Z6/V11/L3/Z7/D4

BAHDM-2038 (PART-12) for Z8/D5

PART-35 MOPU SECT.

MODEL NO. TX-NR555/656/757, TX-RZ610/710/810, HT-R695
DRX-2/3/4/5

SCHEMATIC DIAGRAM (PART-10) DIR/DAC SECTION

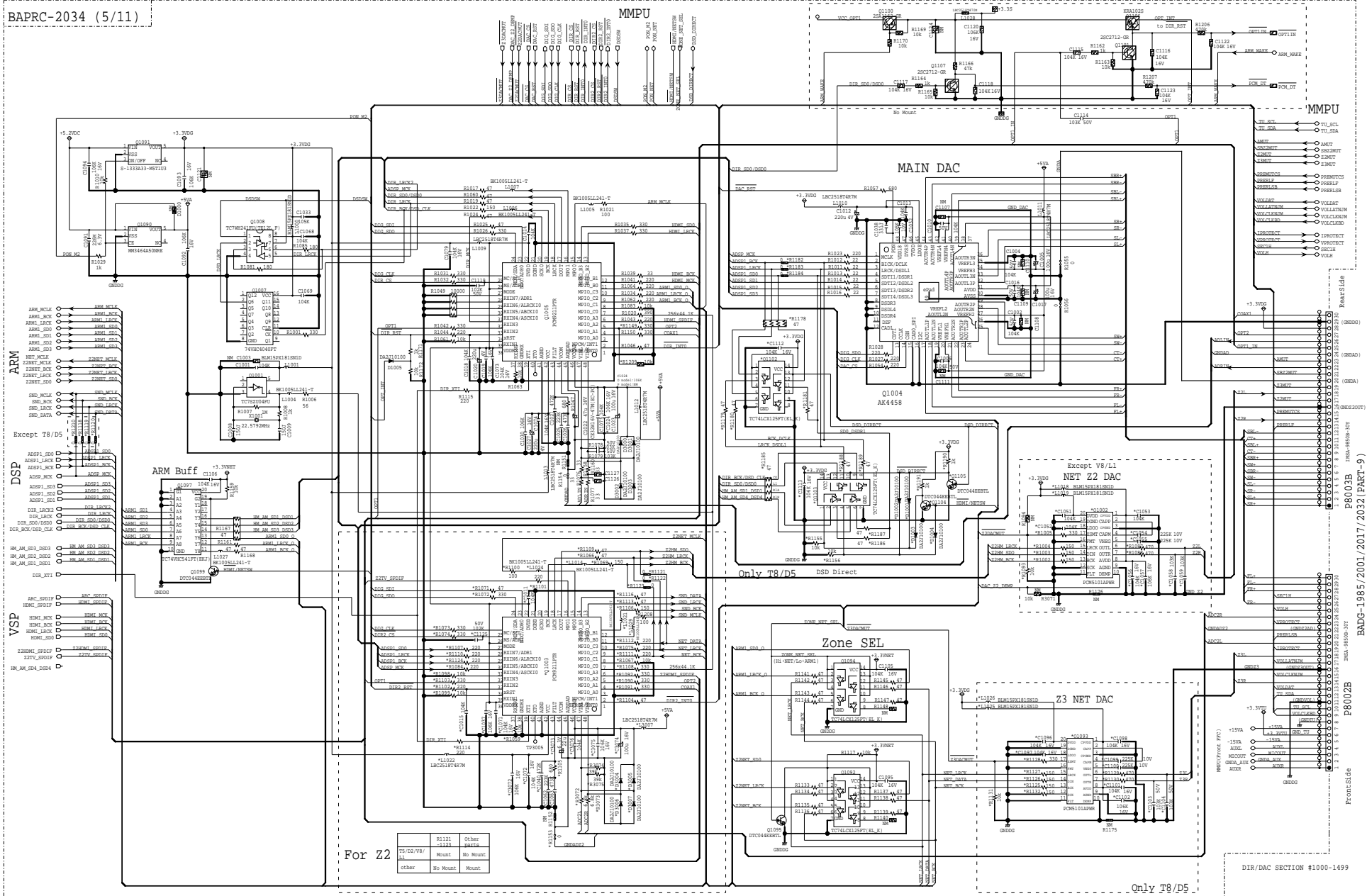

BAPRC-2034 (5/11)

MMPU

MAIN DAC

MMPU

ARM

DSP

VSP

ARM Buff

Only T8/D5 DSD Direct

Except V8/L1 NET Z2 DAC

Zone SEL

Z3 NET DAC

For Z2

Only T8/D5

TI/02/VS/	R1121	Other
11	Mount	No Mount
other	No Mount	Mount

BADG-1985/2001/2017/2032(PART-9)
P8003B

P8002B

DIR/DAC SECTION #1000-1499

MODEL_NO.TX-NR555/656/757, TX-RZ610/710/810, HT-R695

SCHEMATIC DIAGRAM (PART-10) DSP SECTION

BAPRC-2034 (6/11) DRX-2/3/4/5

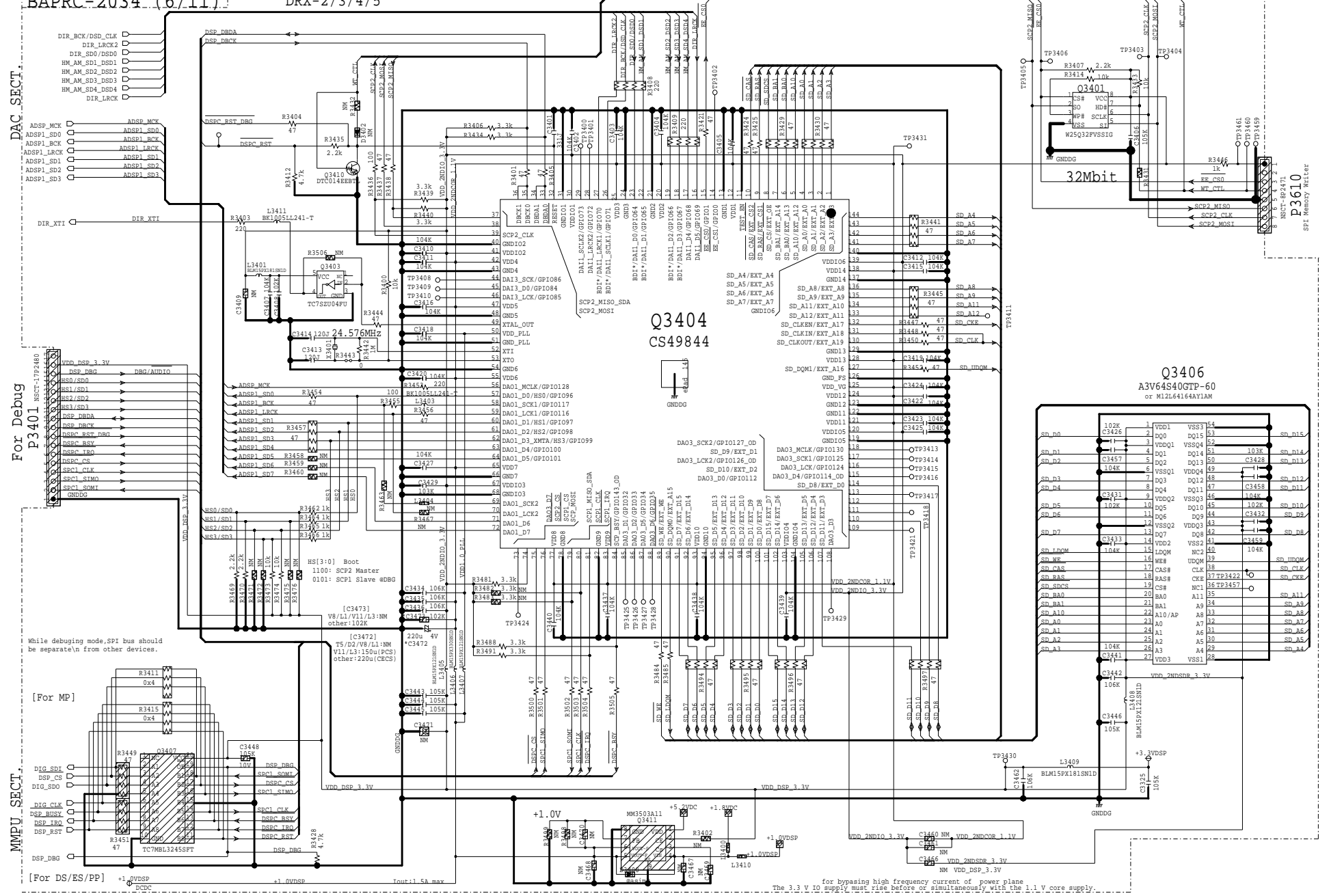

DAC SECT.

DIR_XTI

For Debug P3401

[For MP]

MMPU SECT.

[For DS/ES/PP]

MODEL NO. TX-NR555/656/757, TX-RZ610/710/810, HT-R695
DRX-2/3/4/5

SCHEMATIC DIAGRAM (PART-10) ARM IO SECTION

BAPRC-2034 (7/11)

Debug (UART)

Debug (UART)

Place A-side

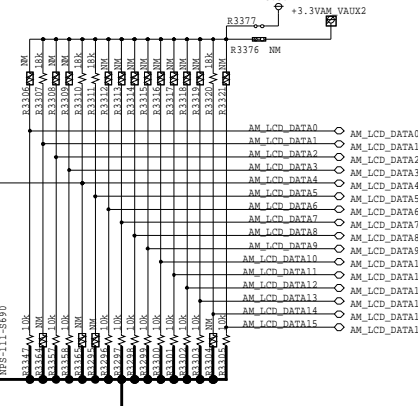
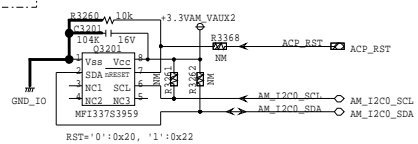
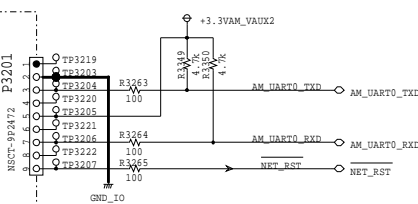

Boot Strap
Boot order: NAND->NANDI2C->USB0->UART0
if DATA4 is Low
Boot order: UART0->SP10->NAND->NANDI2C

MMPU

USB/Ether/Wifi

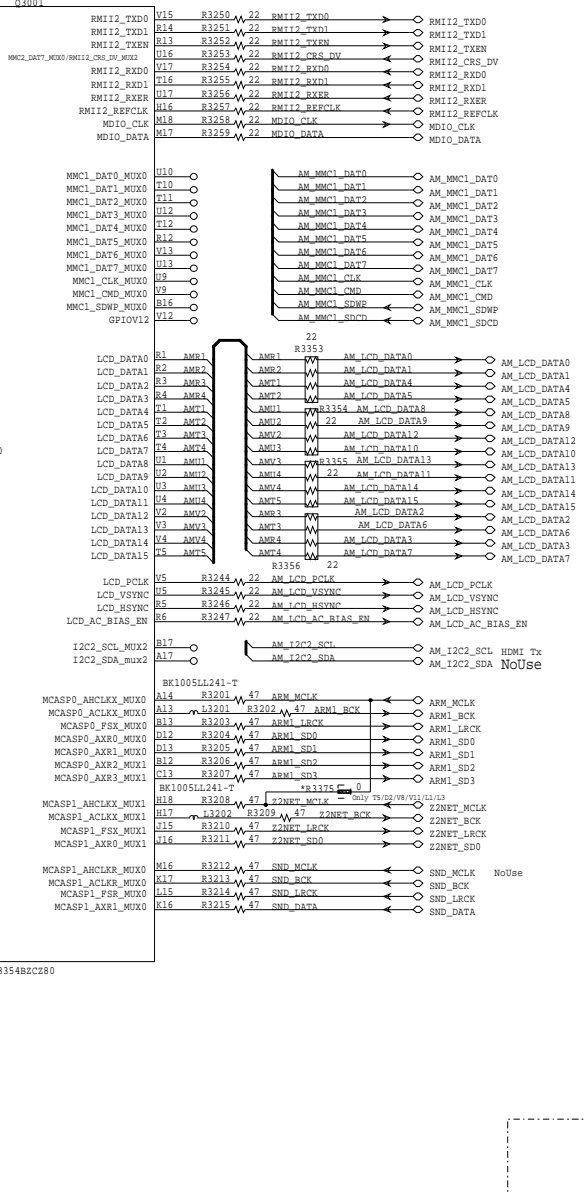
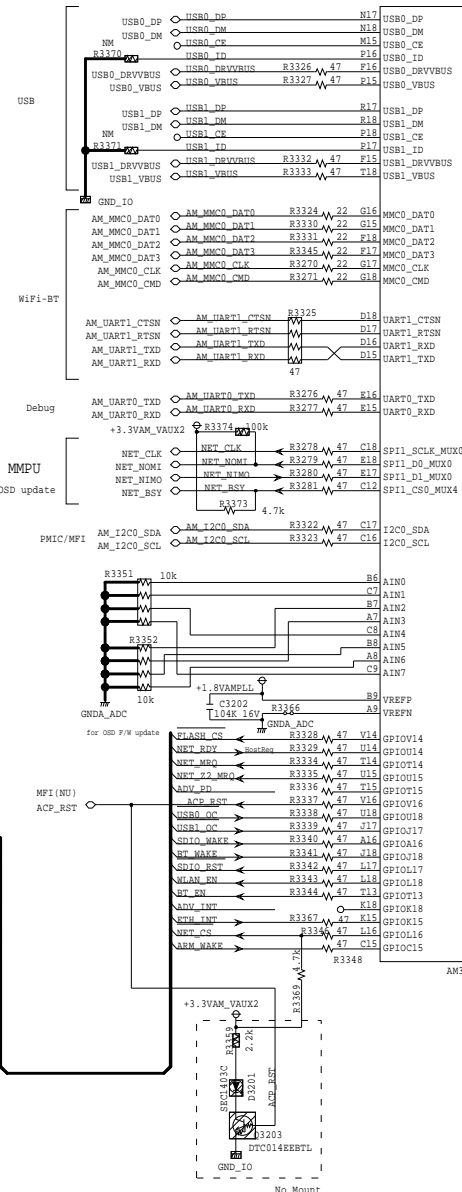

Ethernet

SD/eMMC NoUse

VIDEO VSP

AUDIO DIR/DAC

NoUse

NoUse

NoUse

NoUse

NoUse

NoUse

NoUse



No Mount

ARM memory section

Schematic Diagram

MODEL NO. TX-NR555/656/757, TX-RZ610/710/810, HT-R695
DRX-2/3/4/5

SCHEMATIC DIAGRAM (PART-10)

ARM Memory SECTION

BAPRC-2034 (9/11)

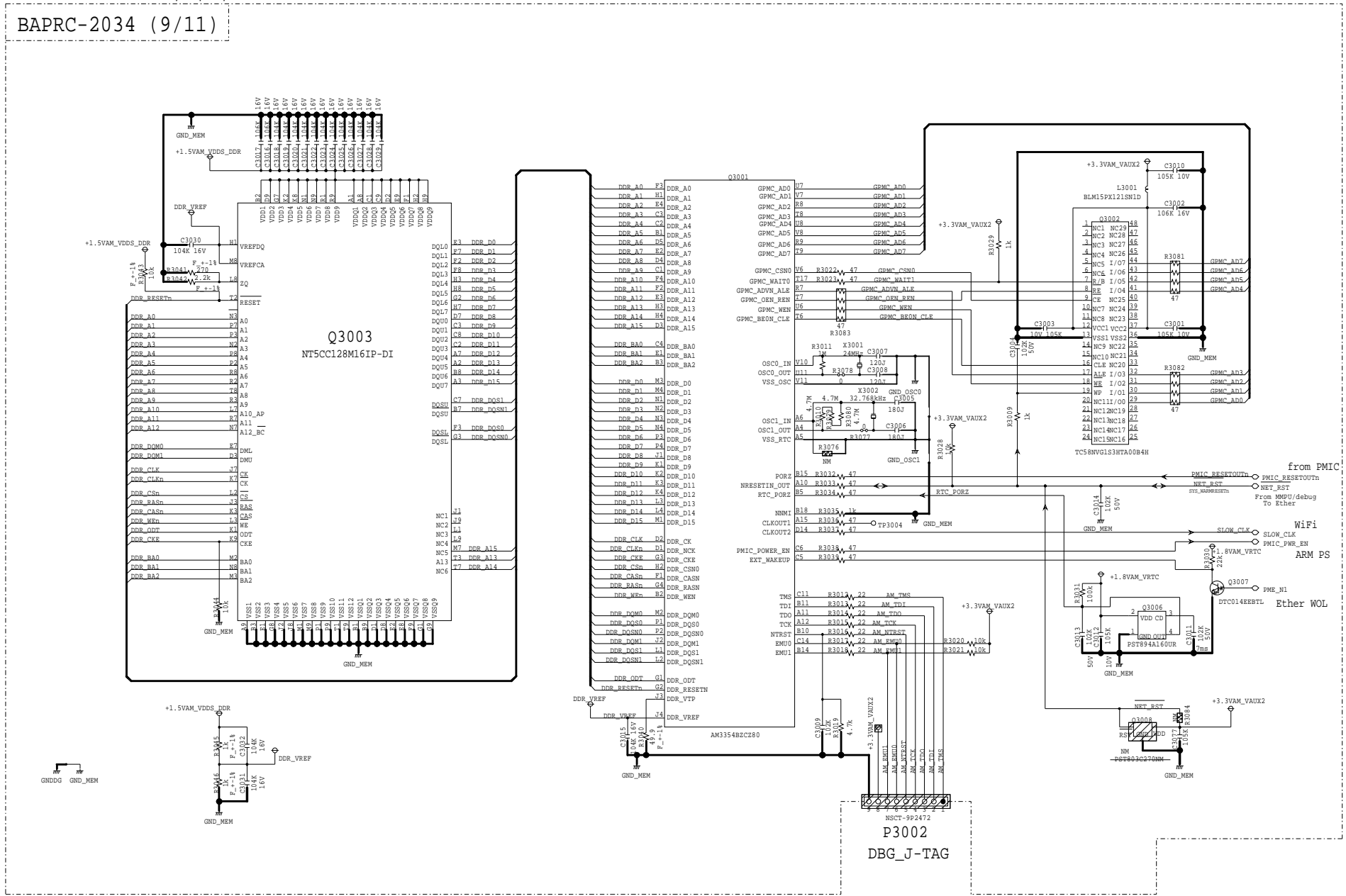

MODEL NO. TX-NR555/656/757, TX-RZ610/710/810, HT-R695
DRX-2/3/4/5

SCHEMATIC DIAGRAM (PART-10)
ARM USB/Ethwernet/WiFi SECTION

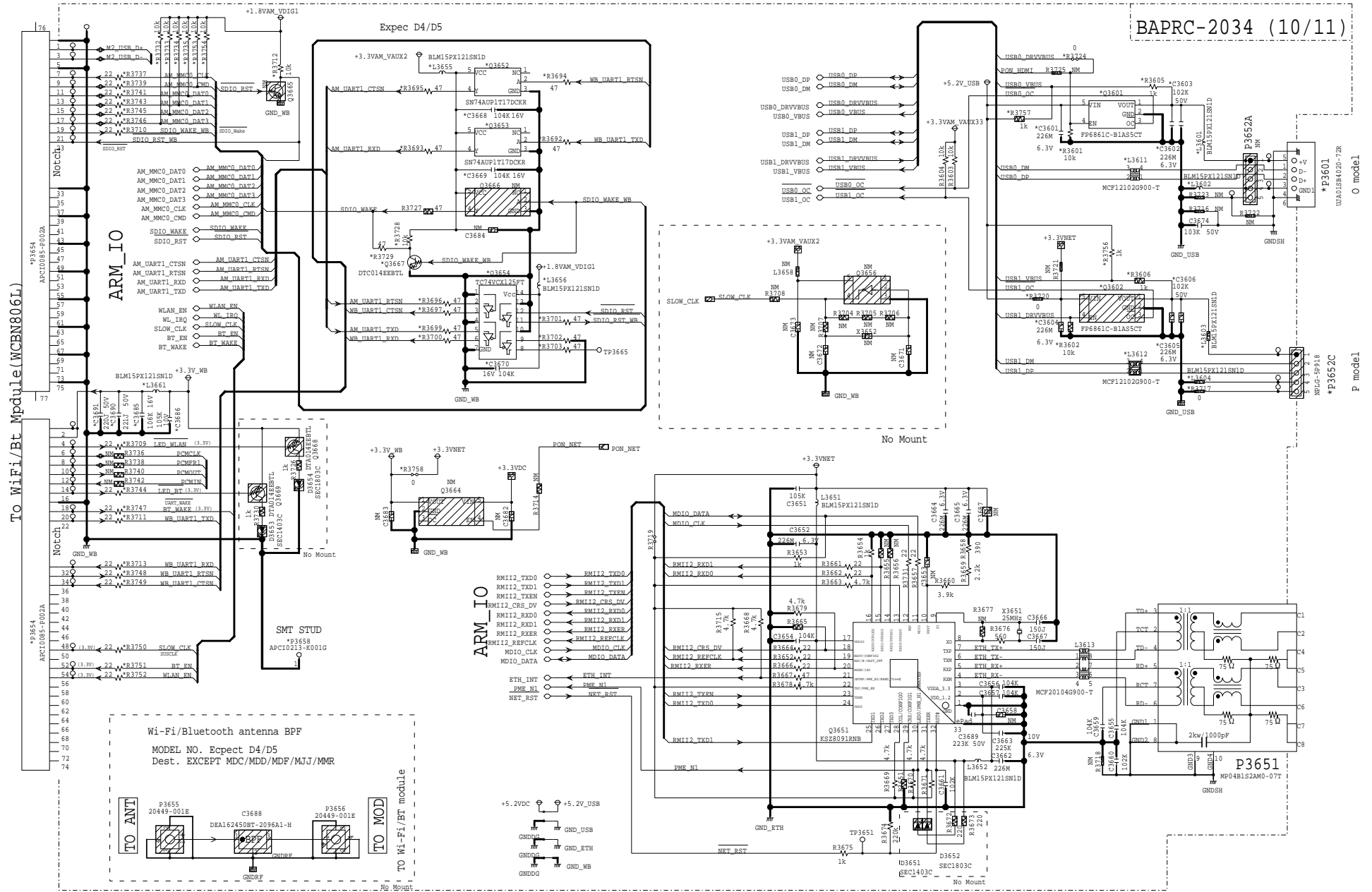

MODEL NO. TX-NR555/656/757, TX-RZ610/710/810, HT-R695
DRX-2/3/4/5

SCHEMATIC DIAGRAM (PART-10) POWER SECTION

BAPRC-2034 (11/11)

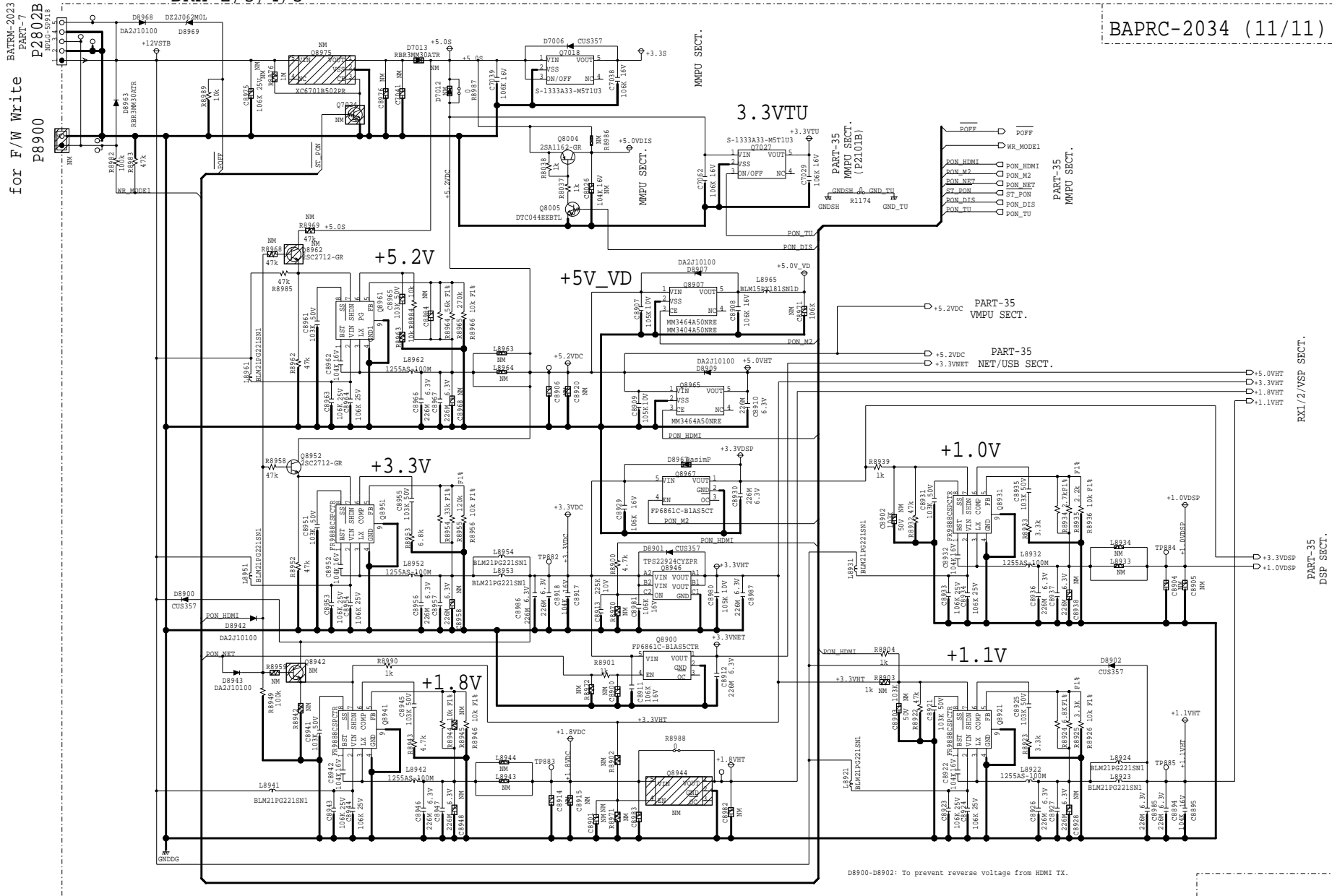

D8900-D8902: To prevent reverse voltage from HDMI TX.

MODEL NO. TX-NR555/656/757, TX-RZ610/710/810, HT-R695, DRX-2/3/4/5

SCHEMATIC DIAGRAM (PART-11) TUNER SECTION

BARF-1987/1995/2003/2012/2019

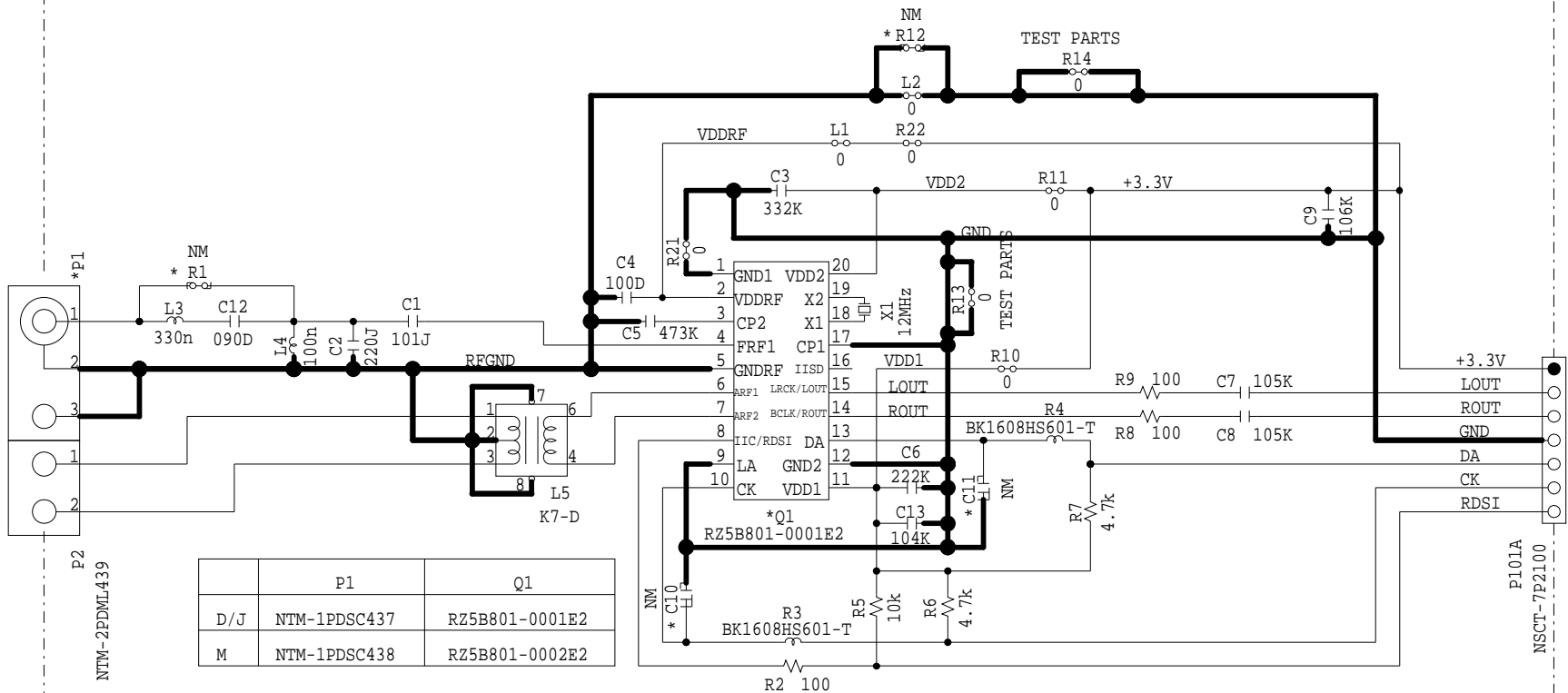

TO BADG-1985/2001/2017/2032(PART-9)

MODEL NO. TX-NR656/757, TX-RZ610/710, HT-R695, DRX-3/4
SCHEMATIC DIAGRAM (PART-12)

FRONT HDMI SECTION

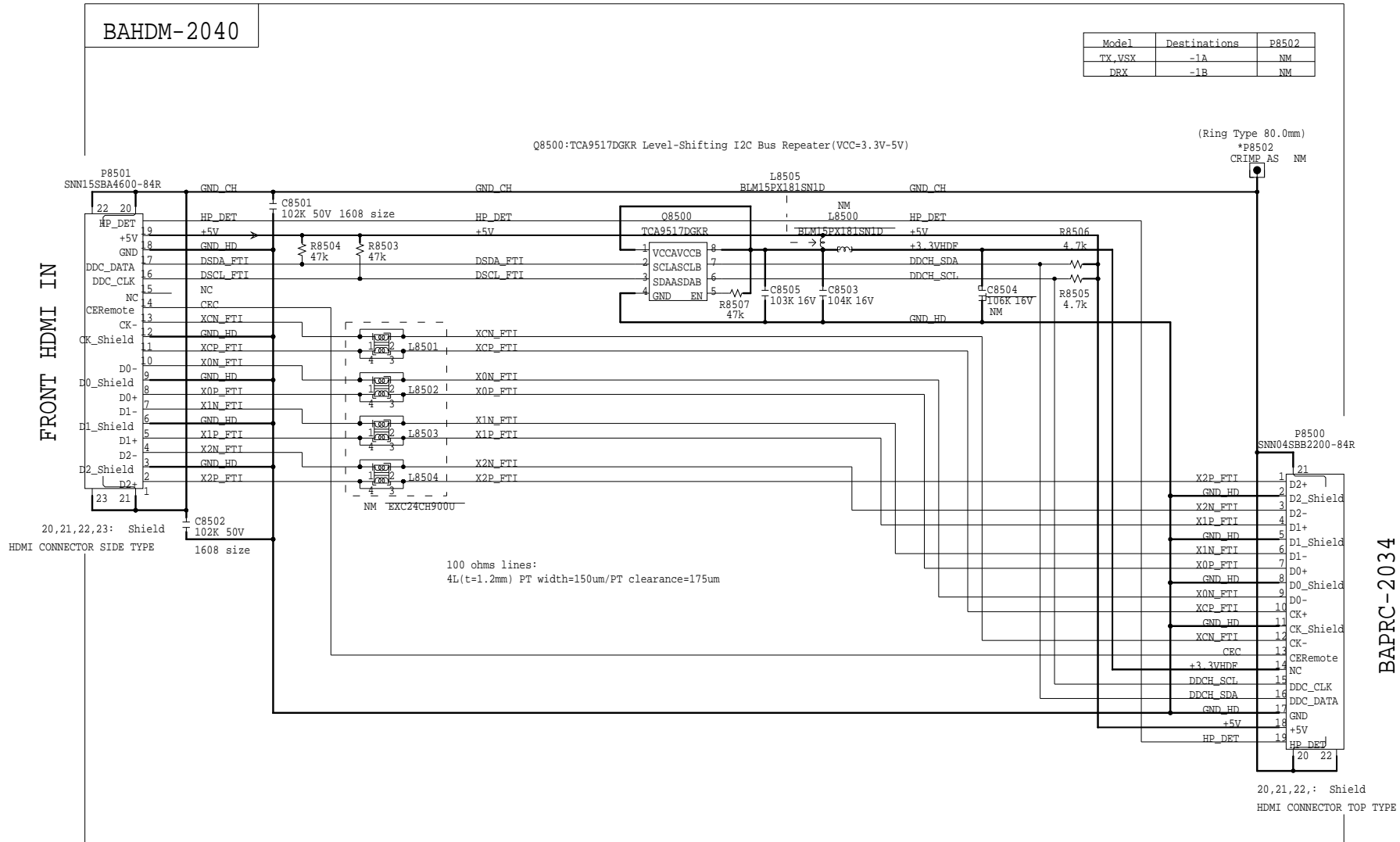

BAPRC-2034
(Part-10 SHEET 39/51)

MODEL NO. TX-RZ810, DRX-5 SCHEMATIC DIAGRAM (PART-12)

FRONT HDMI SECTION

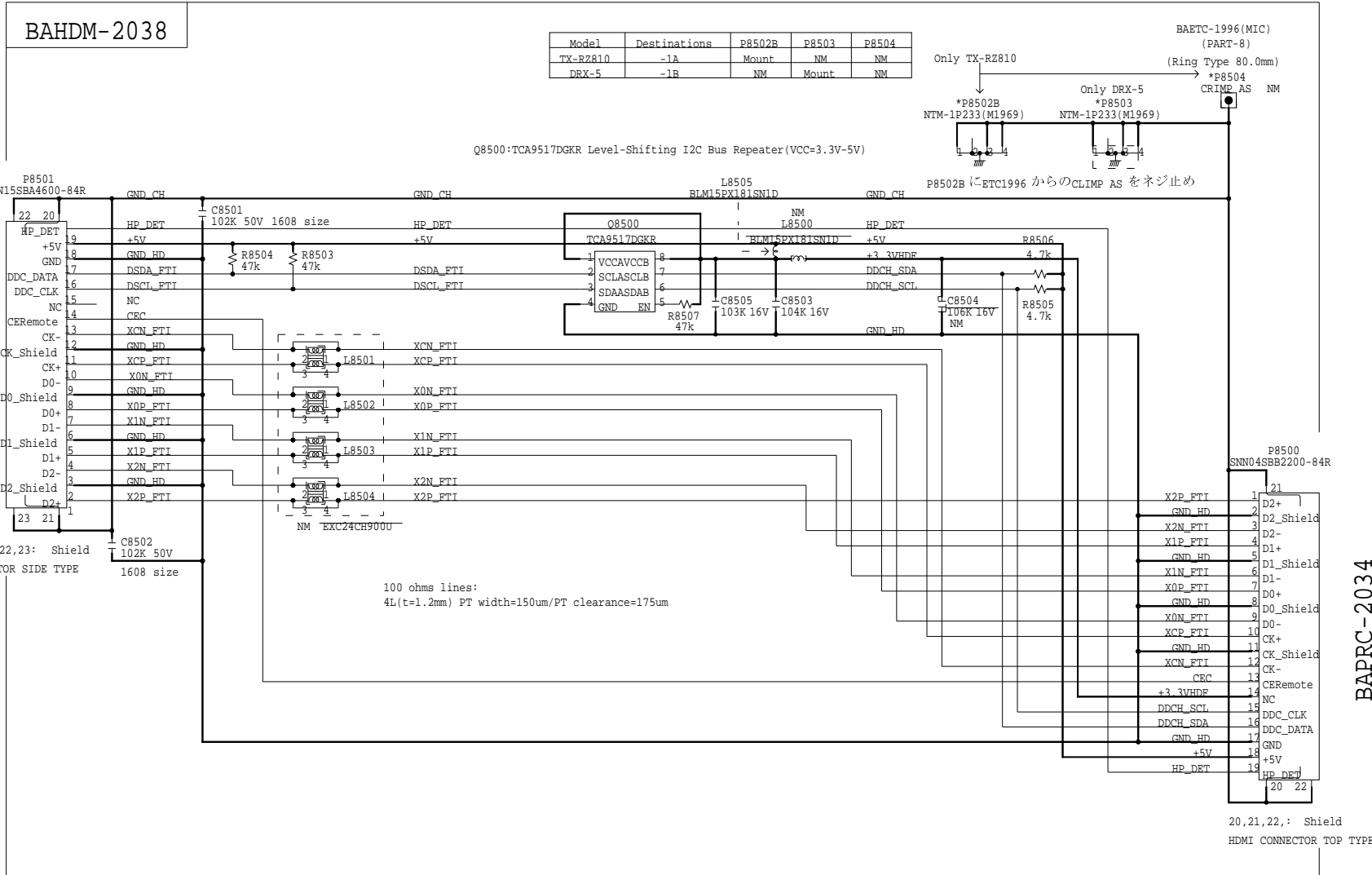

BAPRC-2034
(Part-10 SHEET 39/51)

MODEL NO. DRX-4/5 SCHEMATIC DIAGRAM (PART-13)

HDBaseT SECTION

BAHDM-2042(2/2)

HDBaseT HDMI IN

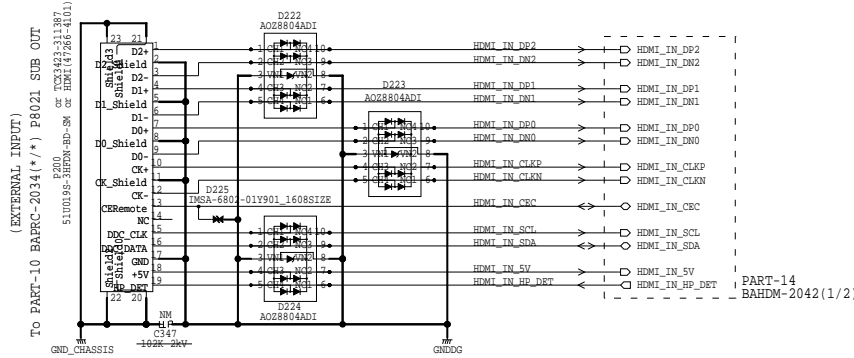

HDBaseT POWER

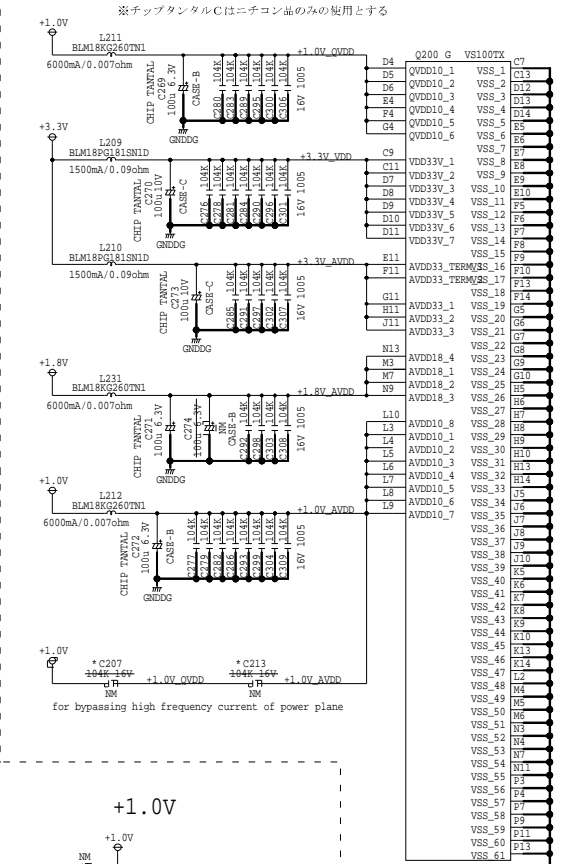

HDBaseT GPIO

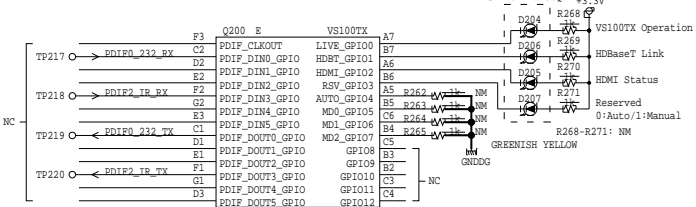

POWER SUPPLY

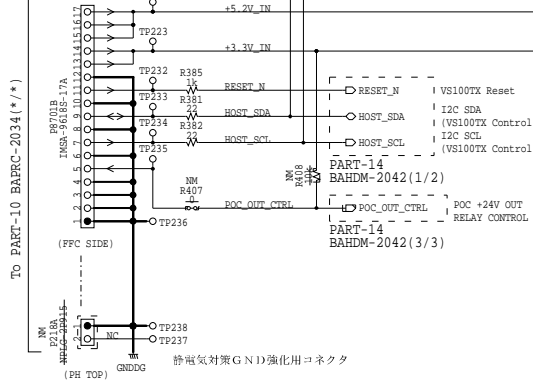
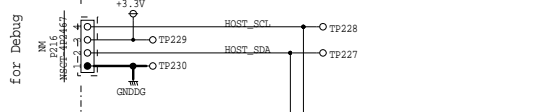
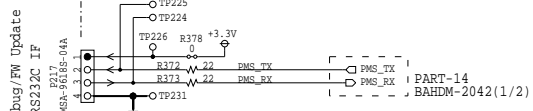
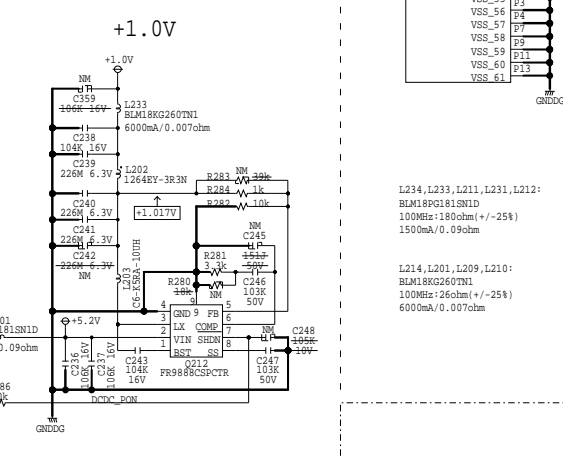
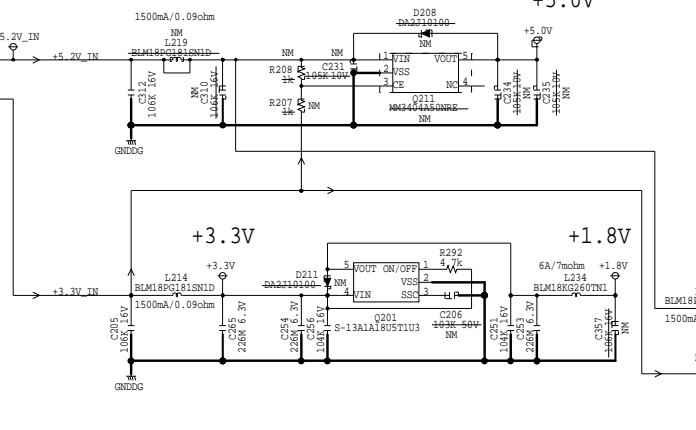

Overview (Shape or q'ty of the terminal, knob: Please check the real model.)

Exploded View

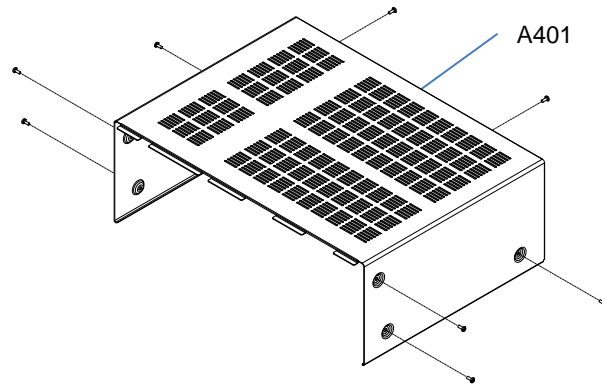

P3654A : WiFi/Bluetooth Module

* This module transmitter does not have RF shielding, therefore it will be equipped only the tested Audio system mentioning this document. Additional test will be required if it will be equipped to the other devices

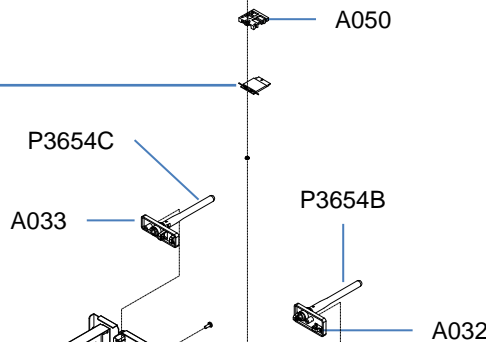

Refer to Front section

Refer to Rear section

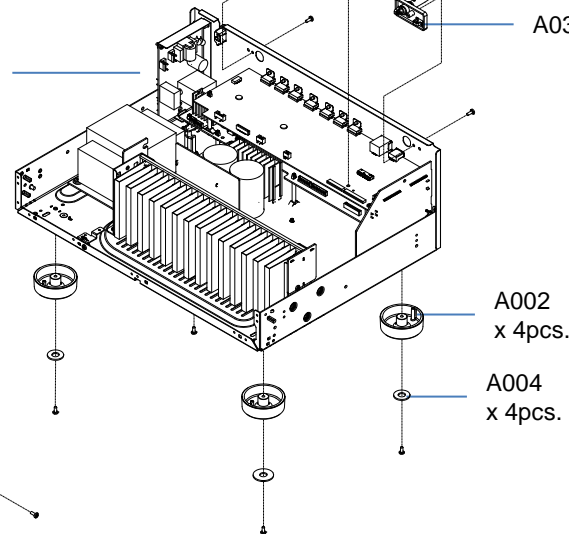
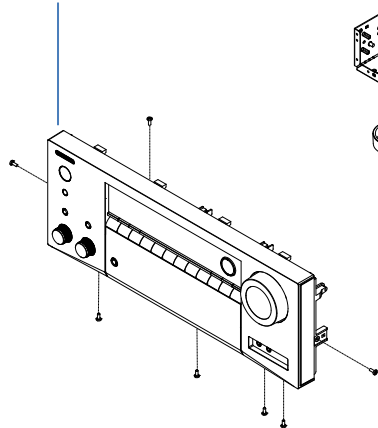

*** WiFi & Bluetooth Module has already been certified by FCC and IC.**

Information to the user.
Indicate "Contains FCC ID: TX2-RTL8821AE", "Contains IC: 6317A-RTL8821AE" and following information to the host device installed.

This device complies with part 15 of the FCC Rules. Operation is subject to the following two conditions: (1) This device may not cause harmful interference, and (2) this device must accept any interference received, including interference that may cause undesired operation.

Describe the following sentence to a user's manual of the host device.

[For FCC]
FCC CAUTION

Changes or modifications not expressly approved by the party responsible for compliance could void the user's authority to operate the equipment.

Note: This equipment has been tested and found to comply with the limits for a Class B digital device, pursuant to part 15 of the FCC Rules. These limits are designed to provide reasonable protection against harmful interference in a residential installation. This equipment generates, uses and can radiate radio frequency energy and, if not installed and used in accordance with the instructions, may cause harmful interference to radio communications. However, there is no guarantee that interference will not occur in a particular installation. If this equipment does cause harmful interference to radio or television reception, which can be determined by turning the equipment off and on, the user is encouraged to try to correct the interference by one or more of the following measures:

- Reorient or relocate the receiving antenna.
- Increase the separation between the equipment and receiver.
- Connect the equipment into an outlet on a circuit different from that to which the receiver is connected.
- Consult the dealer or an experienced radio/TV technician for help.

This transmitter must not be co-located or operated in conjunction with any other antenna or transmitter.

This equipment complies with FCC radiation exposure limits set forth for an uncontrolled environment and meets the FCC radio frequency (RF) Exposure Guidelines in Supplement C to OET65. This equipment has very low levels of RF energy that it deemed to comply without maximum permissive exposure evaluation (MPE). But it is desirable that it should be installed and operated keeping the radiator at least 20cm or more away from person's body (excluding extremities: hands, wrists, feet and ankles).

[For IC]
CAN ICES-3 B/NMB-3 B

This device complies with Industry Canada licence-exempt RSS standard(s). Operation is subject to the following two conditions: (1) this device may not cause interference, and (2) this device must accept any interference, including interference that may cause undesired operation of the device.

Le présent appareil est conforme aux CNR d'Industrie Canada applicables aux appareils radio exempts d'licence. L'exploitation est autorisée aux deux conditions suivantes : (1) l'appareil ne doit pas produire de brouillage, et (2) l'utilisateur de l'appareil doit accepter tout brouillage radioélectrique subi, même si le brouillage est susceptible d'en compromettre le fonctionnement.

This equipment complies with IC radiation exposure limits set forth for an uncontrolled environment and meets RSS-102 of the IC radio frequency (RF) Exposure rules. This equipment has very low levels of RF energy that it deemed to comply without maximum permissive exposure evaluation (MPE). But it is desirable that it should be installed and operated keeping the radiator at least 20cm or more away from person's body (excluding extremities: hands, wrists, feet and ankles).

Cet équipement est conforme aux limites d'exposition aux rayonnements énoncées pour un environnement non contrôlé et respecte les règles d'exposition aux fréquences radioélectriques (RF) CNR-102 de l'IC. Cet équipement émet une énergie RF très faible qui est considérée conforme sans évaluation de l'exposition maximale autorisée. Cependant, cet équipement doit être installé et utilisé en gardant une distance de 20 cm ou plus entre le dispositif rayonnant et le corps (à l'exception des extrémités : mains, poignets, pieds et chevilles).

1 2 3 4 5 6
Front section (Shape or q'ty of the terminal, knob: Please check the real model.)

Exploded View

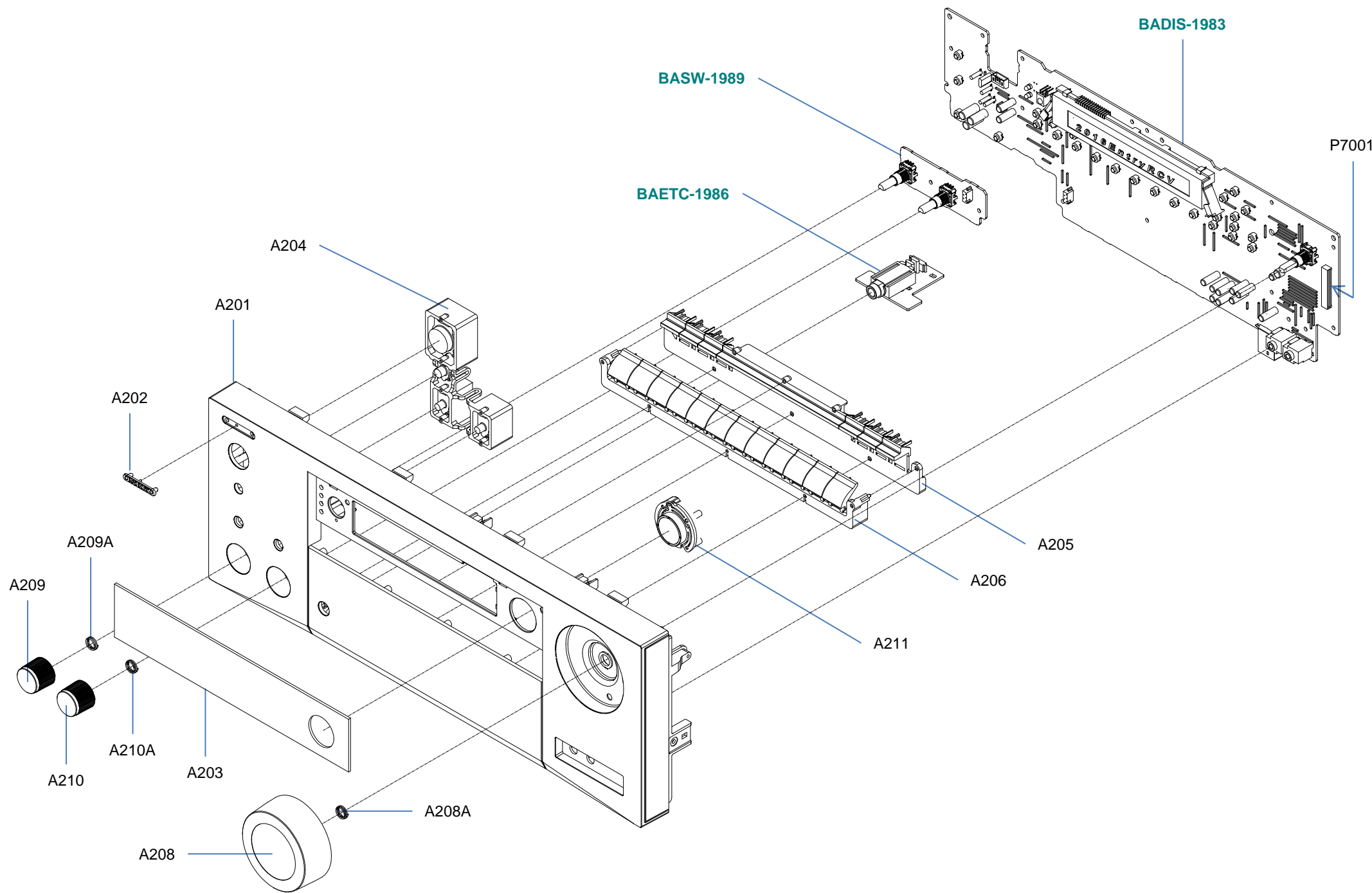

Rear section (Shape or q'ty of the terminal, knob: Please check the real model.)

Exploded View

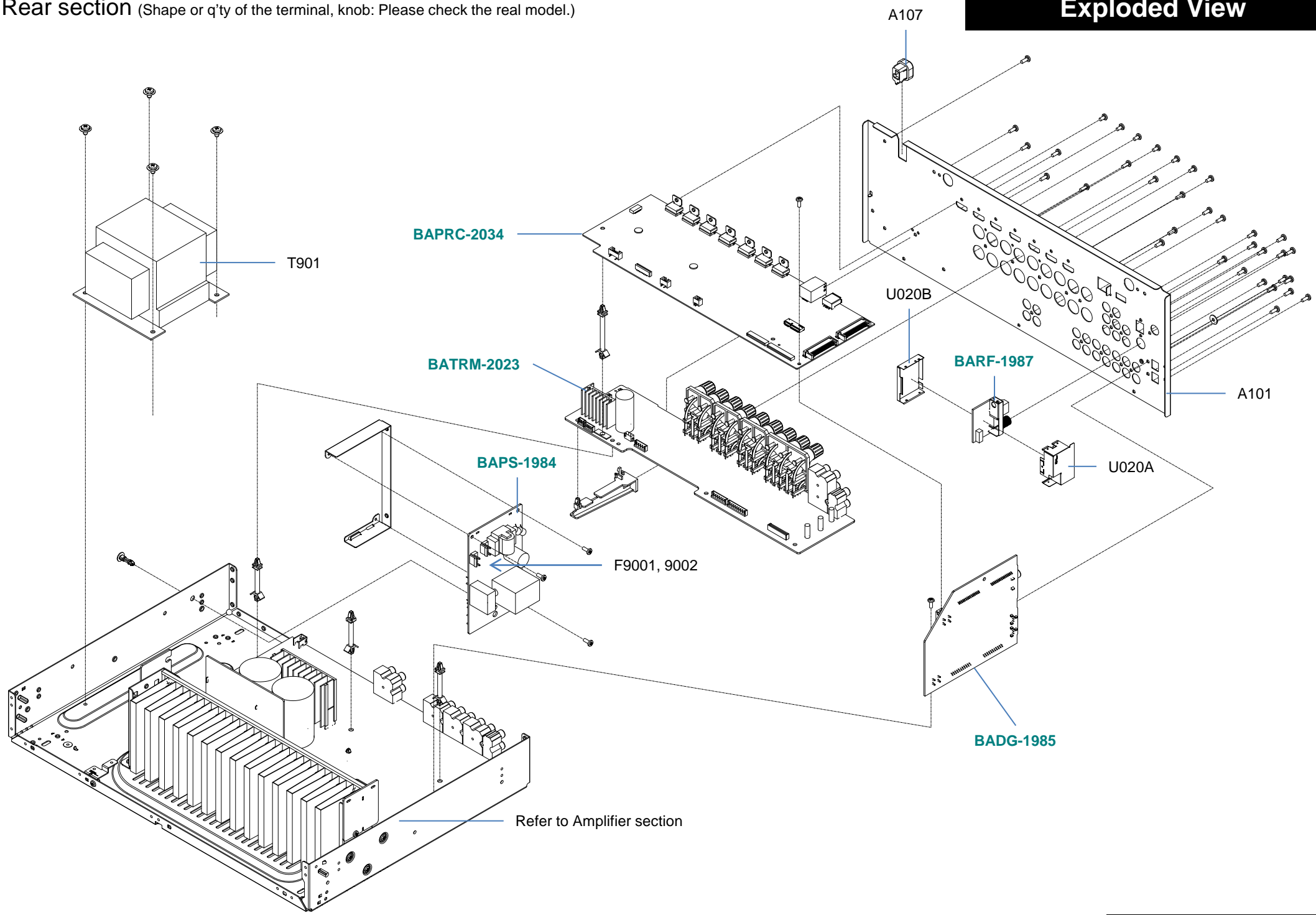

Amplifier section (Shape or q'ty of the terminal, knob: Please check the real model.)

Exploded View

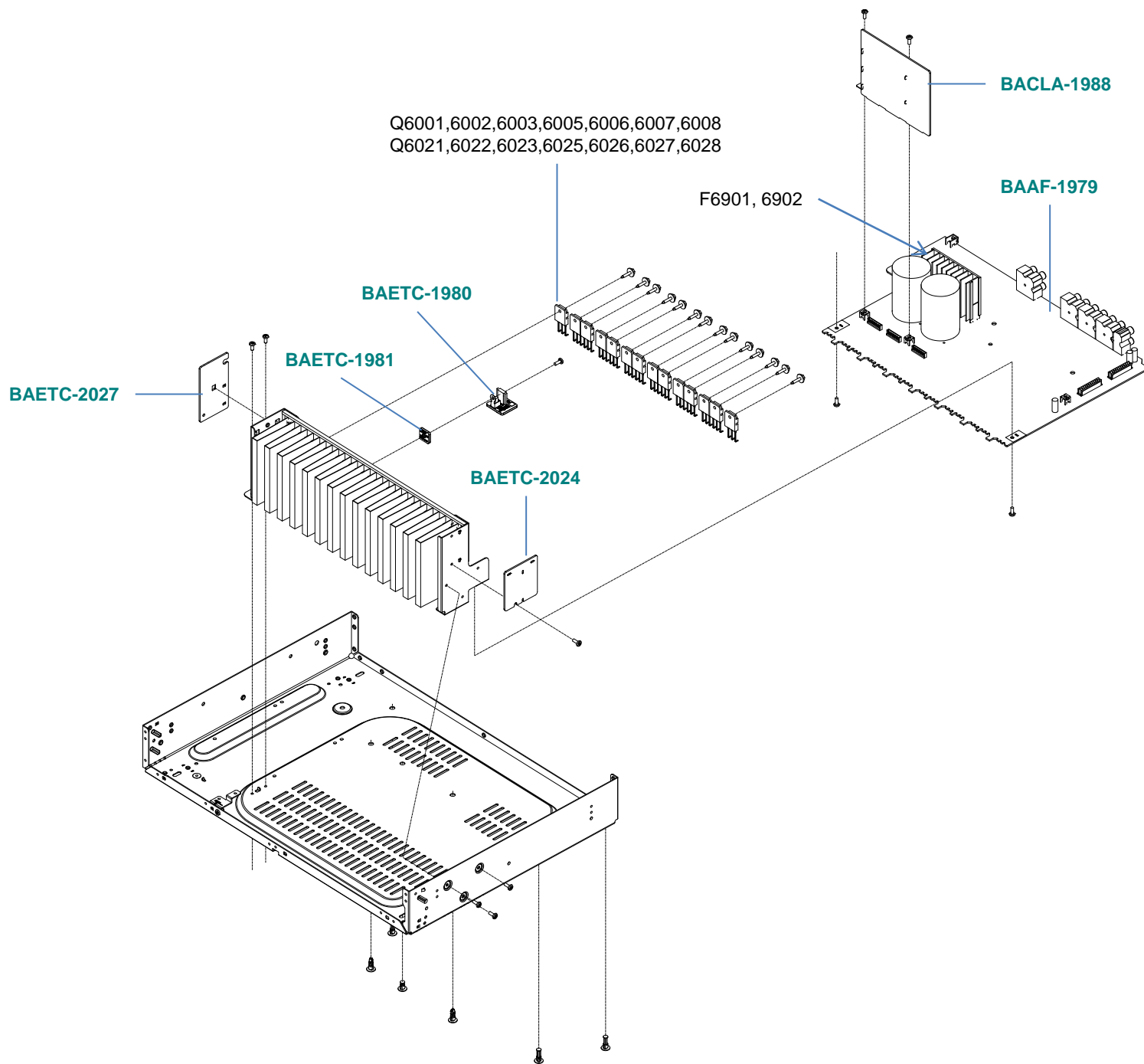

Model List

Abbreviated Model Name	Full Model Name
T5	TX-NR555
T6	TX-NR656
Z6	TX-RZ610
H6	HT-R695
T7	TX-NR757
Z7	TX-RZ710
Z8	TX-RZ810
D2	DRX-2
D3	DRX-3
D4	DRX-4
D5	DRX-5

※**J(like T6J) is MJJ of model.

※List

Abbreviated Model Name	※List-A	※List-B	※List-C	※List-D	※List-E
T5/T6/Z6/H6/T7/Z7/Z8	DIMMER	Rotate rotary encoder of TONE	TONE	TV	TONE
D2/D3/D4/D5	DIMMER or INFO or Tone+	TONE+	TONE or MEMORY	TV	TONE or MEMORY

TX-NR555/NR656
 HT-R695
 TX-RZ610
 DRX-2/3

Operation check

About Button Action

Use the following expression simplify description button operation.

Example-1 :

[TV/CD] + [ON/STANDBY] → [BD/DVD]

Means press and hold [ON/STANDBY] button while pressing [TV/CD] button, then press [BD/DVD] button.

Example-2 :

[DISPLAY] + [ON/STANDBY] x 2 → [DIMMER] or [RT/PTY/TP]

Means press and hold [ON/STANDBY] button two times while pressing [DISPLAY] button, then press [DIMMER] or [RT/PTY/TP] button.

How to check MAIN Checksum

Step1 : Set VOL Level = 40

Step2 : [List-A(※)] + [ON/STANDBY] x 2 → [ENTER]

Initial Setting for Shipping (Service Information is also cleared.)

Step1 : Set VOL Level = 40

Step2 : [List-E (※)] + [ON/STANDBY] → [Return] x 2

Display "All Clear" of FL tube and AVR goes standby.

Step3 : Unplug the power cord

How to check FL Tube and LED Operation

Step1 : Set VOL Level = 40

Step2 : [List-D (※)] + [ON/STANDBY] → [DIMMER]

Lit all FL-Segment and LED.

Step3 : [List-B (※) +]

Lit '23456789ABCDEF'.

Step4 : [List-B (※) +]

Lit a even number segment.

Step5 : [List-B (※) +]

Lit an odd number segment.

Step6 : [List-B (※) +]

Lit 'DIMMER CHECK: 255'.

Step7 : [List-B (※) +]

The Destination setting is displayed.

※ : Refer to [Model List](#).

HDMI resolution display

HDMI-related operations can be checked to some extent by displaying HDMI resolution display mode.

How to enter to this mode

[ENTER] Hold down for 3 seconds

Display of the input signal (for 5 seconds)



Display of the output signal (for 5 seconds)

HDMI resolution display

Normal input signal

Digital

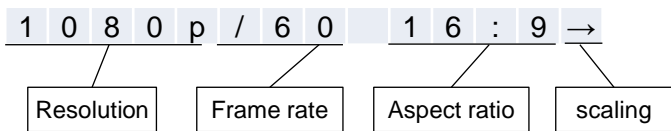

Analog

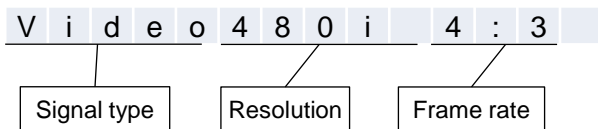

Input signal	Display
• DVI	<div style="border: 1px solid black; padding: 2px; display: inline-block;">4 8 0 i / 6 0 D V I</div> <div style="border: 1px solid black; padding: 2px; display: inline-block;">4 8 0 P / 6 0 D V I</div>
• VGA(DVI)	<div style="border: 1px solid black; padding: 2px; display: inline-block;">* V G A / 5 9 4 : 3</div>
• Pixel Repetition	Pixel Rep. 2: D (Except 480i) Pixel Rep. 4: Q <div style="border: 1px solid black; padding: 2px; display: inline-block;">D 4 8 0 p / 6 0 1 6 : 9</div> Pixel Rep. 8: O
• CVBS	<div style="border: 1px solid black; padding: 2px; display: inline-block;">V i d e o 4 8 0 i 4 : 3</div>
• Component	<div style="border: 1px solid black; padding: 2px; display: inline-block;">C M P 5 7 6 i 1 6 : 9</div>
• 21:9 (Pixel AR ≠ 1:1)	<div style="border: 1px solid black; padding: 2px; display: inline-block;">1 0 8 0 p / 6 0 2 1 : 9</div>
• 21:9 (Pixel AR = 1:1)	<div style="border: 1px solid black; padding: 2px; display: inline-block;">1 0 8 0 w / 6 0 2 1 : 9</div>
• LTE TMDS Clock340MHz (Scrambled input)	<div style="border: 1px solid black; padding: 2px; display: inline-block;">1 0 8 0 p / 6 0 S 1 6 : 9</div>
• No input	<div style="border: 1px solid black; padding: 2px; display: inline-block;">U n k n o w n</div>

HDMI resolution display

Normal output signal

Output resolution

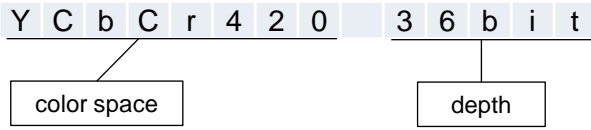

Output resolution (4k scaling)



Output resolution (dawn scaling)



Output resolution (IP converter)



Onput signal	Display
• RSEN OFF	[][][][][][R][G][B][][4][8][b][][*]
• EDID_READ_NG	[][][][][][D][V][I][][2][4][b][][#]
• Resolution Error	[Y][C][b][C][r][4][4][4][][4][8][b][][E]
• DVI	[][][][][][D][V][I][][2][4][b][i][T]
• No output	[][][][][][][][-][-][-][-][-][][]
• 4096 x 2160p sclae	[4][K][6][0][p][R][G][B][#][2][4][b][i][t]
• LTE340MHz (Scrambled output)	[][][][][][R][G][B][][2][4][b][][S]
• Signal generate	[][4][8][0][p][R][G][B][][G][e][n][][]
• Cannot detect the hot-plug	[][][][][][][][O][F][F][][]

HDMI resolution display

3D input signal

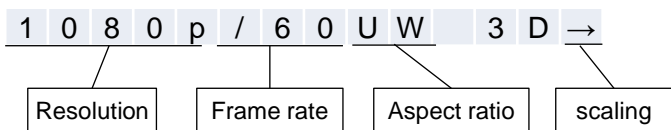

Display Status (Normal output resolution)

4 K 6 0 p 4 4 4 2 4 b i t



3D format

S i d e b y S i d e (H)

• 3D aspect ratio	<ul style="list-style-type: none"> • 4:3→SD • 16:9→None • 21:9→UW 	1 0 8 0 P / 6 0 U W 3 D →
-------------------	--	---------------------------

3D format	Display
• Frame Packing	F r a m e P a c k i n g
• Field alternative	F a l t e r n a t i v e
• Line alternative	L a l t e r n a t i v e
• Side-by-Side(Full)	S i d e b y S i d e (F)
• L+depth	L + d e p t h
• L+depth + graphics	L + d e p t h g r a p h i c
• Side by Side(Harf)	S i d e b y S i d e (H)
• Top and Bottom	T o p - a n d - B o t t o m
• unknown	U n k n o w n

HDMI resolution display

PC input signal

Input resolution

1 0 2 4 x 7 6 8 p / 6 0



Output resolution

Y C b C r 4 2 4 3 6 b i t

Input Signal	Display																											
	<table border="1"> <tr> <td>*</td><td>*</td><td>*</td><td>*</td><td>x</td><td>*</td><td>*</td><td>*</td><td>*</td><td>p</td><td>/</td><td>*</td><td>*</td><td></td> </tr> <tr> <td colspan="5">Horizontal</td> <td colspan="4">Vertical</td> <td colspan="4">Ref Rate</td> </tr> </table>	*	*	*	*	x	*	*	*	*	p	/	*	*		Horizontal					Vertical				Ref Rate			
*	*	*	*	x	*	*	*	*	p	/	*	*																
Horizontal					Vertical				Ref Rate																			
• DVI	Big 'P' <table border="1"> <tr> <td>1</td><td>0</td><td>2</td><td>4</td><td>x</td><td></td><td>7</td><td>6</td><td>8</td><td>P</td><td>/</td><td>6</td><td>0</td><td></td> </tr> </table>	1	0	2	4	x		7	6	8	P	/	6	0														
1	0	2	4	x		7	6	8	P	/	6	0																
• HDMI	Small 'p' <table border="1"> <tr> <td>1</td><td>0</td><td>2</td><td>4</td><td>x</td><td></td><td>7</td><td>6</td><td>8</td><td>p</td><td>/</td><td>6</td><td>0</td><td></td> </tr> </table>	1	0	2	4	x		7	6	8	p	/	6	0														
1	0	2	4	x		7	6	8	p	/	6	0																
• Ref Rate 3 digit	<table border="1"> <tr> <td>1</td><td>0</td><td>2</td><td>4</td><td>x</td><td></td><td>7</td><td>6</td><td>8</td><td>P</td><td>1</td><td>2</td><td>0</td><td></td> </tr> </table>	1	0	2	4	x		7	6	8	P	1	2	0														
1	0	2	4	x		7	6	8	P	1	2	0																
• LTE 340MHz	<table border="1"> <tr> <td>1</td><td>0</td><td>2</td><td>4</td><td>x</td><td></td><td>7</td><td>6</td><td>8</td><td>P</td><td>1</td><td>2</td><td>0</td><td>s</td> </tr> </table>	1	0	2	4	x		7	6	8	P	1	2	0	s													
1	0	2	4	x		7	6	8	P	1	2	0	s															
• No input	<table border="1"> <tr> <td>U</td><td>n</td><td>k</td><td>n</td><td>o</td><td>w</td><td>n</td><td></td><td></td><td></td><td></td><td></td><td></td><td></td> </tr> </table>	U	n	k	n	o	w	n																				
U	n	k	n	o	w	n																						

Cooling fan

Cooling Fan

E.g. (TX-RZ800)

OFF	0V
LOW	2.0V
MID	2.7V
HIGH	3.3V

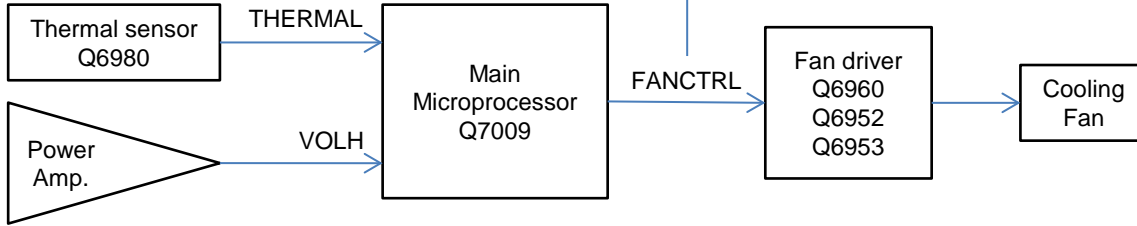
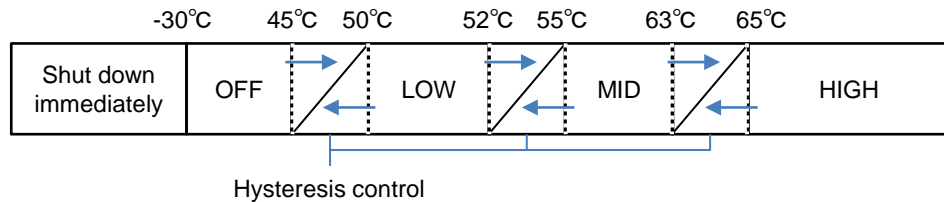

Table of THERMAL and VOLH

		VOLH			
		OFF or Headphone	LOW	MID	HIGH
THERMAL	OFF	STOP	STOP	STOP	STOP
	LOW	LOW	LOW	LOW	LOW
	MID	LOW	MID	MID	MID
	HIGH	HIGH	HIGH	HIGH	HIGH

THERMAL (Temperature of thermal sensor)



VOLH (Voltage of VOLH port)

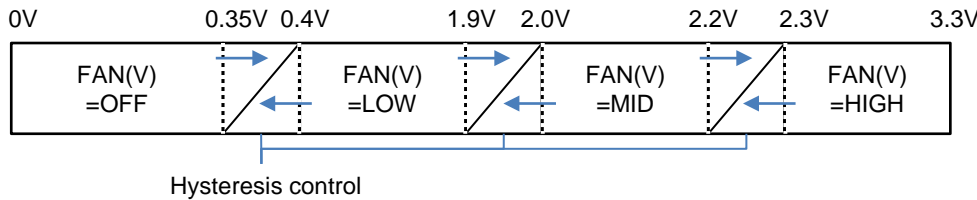

How to check cooling fan

Step1 : Set VOL Level = 40

Step2 : Confirm fan that is not rotating.

Step3 : Set the following test mode and confirm fan that is rotating at low speed.
TEST 1-08 :
[TV] + [ON/STANDBY] → [CBL/SAT] or [CBL] → [TONE-] x 3

Step4 : Set the following test mode and confirm fan that is rotating at high speed.
TEST 1-07 :
[TV] + [ON/STANDBY] → [CBL/SAT] or [CBL] → [TONE-] x 4

※**Note:** Do not connect speaker during this check.

How to display Output Sensor & Temperature Sensor

[List-A (※)] + [ON/STANDBY] x 2 → [List-C (※)]

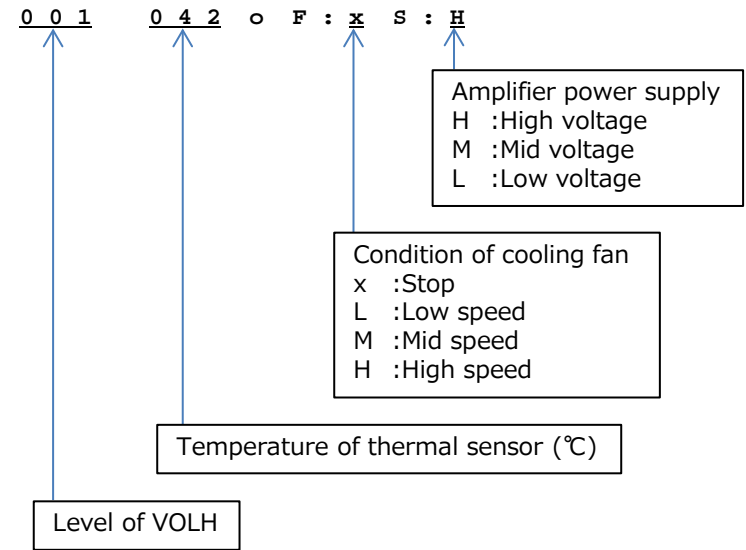

※ : Refer to [Model List](#).

Service information

Displaying Service information

This service information display system is helpful in analyze the status when the unit goes into Protect mode and is powered off. Pay attention that the status will change if a button is pushed.

How to enter to service information mode.

Step1 :
[DIMMER] + [ON/STANDBY] x 2

M1.xx / xxxxxAEx

The version of main microprocessor.
(displayed only for 3 seconds)

Step2 :
[SETUP] or [HOME]

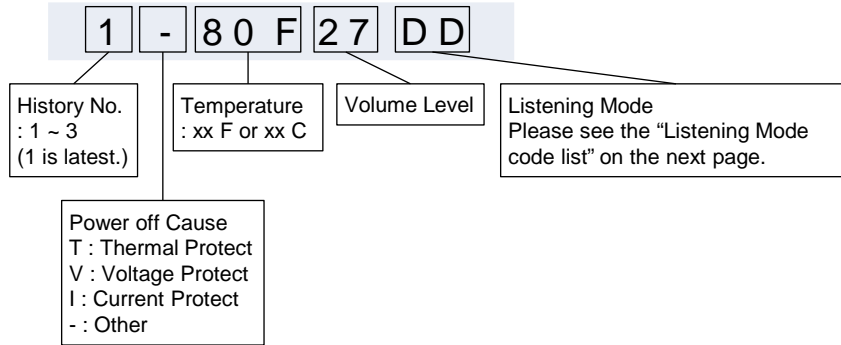

Step3 :
[SETUP] or [HOME]

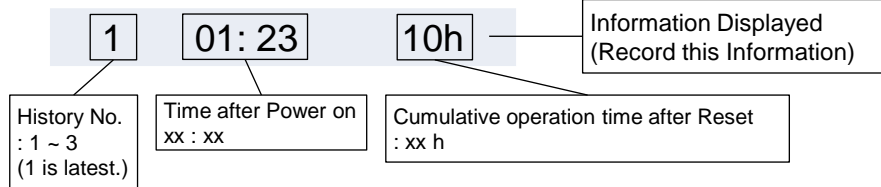

Note)

If press [ENTER] during service information mode, the following display will appear. And Self-diagnostic will start at when next turn on.

A M P D I A G N O S T I C T E S T O N

Appendix

How to change History No. 1 ~ 3.

[CURSOR UP] or [CURSOR DOWN]

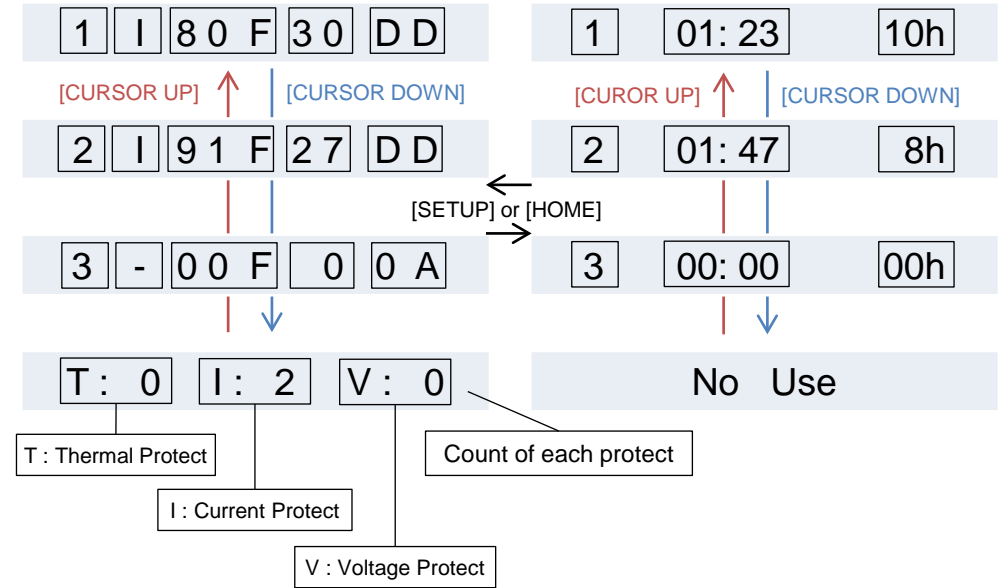

How to exit the service information mode.

[ON/STANDBY]

Normal display

[RETURN] (to initialize the data in the service information.)

Protect Data CLR

Normal display

TX-NR555/NR656
HT-R695
TX-RZ610
DRX-2/3

Service Information

Appendix

Listening Mode Code List

00	NORMAL_LMD_BEGIN	20	SURR_LMD_BEGIN	50	THX_MUSIC_LMD_BEGIN	90	THX_CINEMA_LMD_BEGIN	D0	AUDYSSEY_LMD_BEGIN
01	LAST	21	SURR_20_PLII_MOVIE	51	THX_20_PLII_MUSIC	91	THX_20_PLII_MOVIE	D1	AUDYSSEY_20_PLII_MUSIC
02	PURE	22	SURR_20_PLII_MUSIC	52	THX_20_PLIIX_MUSIC	92	THX_20_PLIIX_MOVIE	D2	AUDYSSEY_20_PLIIX_MUSIC
03	DIRECT	23	SURR_20_PLII_GAME	53	THX_20_PLIIZ_MUSIC	93	THX_20_PLIIZ_CINEMA	D3	AUDYSSEY_20_NEO6_MUSIC
04	STEREO	24	SURR_20_PLIIX_MOVIE	54	THX_20_NEO6_MUSIC	94	THX_20_NEO6_MOVIE	D4	AUDYSSEY_20_NEURAL_CINEMA
05	MONO	25	SURR_20_PLIIX_MUSIC	55	THX_20_NEURAL_MUSIC	95	THX_20_NEURAL_CINEMA	D5	AUDYSSEY_20_NEURAL_MUSIC
06	ORCHESTRA	26	SURR_20_PLIIX_GAME	56	THX_51_OFF_MUSIC	96	THX_51_OFF_CINEMA	D6	AUDYSSEY_20_PLII_MOVIE
07	UNPLUGGED	27	SURR_20_PLIIZ	57	THX_51_MTR_MUSIC	97	THX_51_MTR_CINEMA	D7	AUDYSSEY_20_PLIIX_MOVIE
08	STUDIOMIX	28	SURR_20_NEO6_MOVIE	58	THX_51_DSC_MUSIC	98	THX_51_DSC_CINEMA	D8	AUDYSSEY_20_NEO6_MOVIE
09	TVLOGIC	29	SURR_20_NEO6_MUSIC	5A	THX_51_PLIIX_MUSIC	99	THX_51_NEO6_CINEMA	D9	AUDYSSEY_20_PLII_GAME
0A	ALLCHST	2A	SURR_20_NEURAL_MUSIC	5B	THX_51_PLIIZ_MUSIC	9A	THX_51_PLIIX_MOVIE	DA	AUDYSSEY_20_PLIIX_GAME
0B	FULLMONO	2B	SURR_20_NEURAL_CINEMA	5C	THX_51_NEO6_MUSIC	9B	THX_51_PLIIZ_CINEMA	DB	AUDYSSEY_51_OFF
0C	TD	2C	SURR_51_OFF	5D	THX_51_NEURAL_MUSIC	9C	THX_51_NEURAL_CINEMA	DC	AUDYSSEY_51_PLIIX_MUSIC
0D	RPG	2D	SURR_51_MTR	5E	THX_20_NEOX_MUSIC	9D	THX_51_EX	DD	AUDYSSEY_51_PLIIX_MOVIE
0E	ACTION	2E	SURR_51_DSC	5F	THX_51_NEOX_MUSIC	9E	THX_20_NEOX_CINEMA	DE	AUDYSSEY_51_NEO6
0F	ROCKBAND	2F	SURR_51_NEO6	60	THX_20_DOLBY_SURR_MUSIC	9F	THX_51_NEOX_CINEMA	DF	AUDYSSEY_51_NEURAL_CINEMA
10	SPORTS	30	SURR_51_EX	61	THX_51_DOLBY_SURR_MUSIC	A0	THX_20_DOLBY_SURR_CINEMA	E0	// AUDYSSEY_51_NEURAL_MUSIC
11	WHOLEHOUSE	31	SURR_51_PLIIX_MOVIE	62	THX_MUSIC_LMD_END	A1	THX_51_DOLBY_SURR_CINEMA	E1	AUDYSSEY_51_EX
12	RPG_GENRE	32	SURR_51_PLIIX_MUSIC			A2	THX_CINEMA_LMD_END	E2	AUDYSSEY_LMD_END
13	ACTION_GENRE	33	SURR_51_PLIIZ	70	THX_GAME_LMD_BEGIN				
14	ROCKBAND_GENRE	34	SURR_51_NEURAL_CINEMA	71	THX_20_PLII_GAME	B0	THX_U2GAME_LMD_BEGIN	F0	SPECIAL_LMD_BEGIN
15	SPORTS_GENRE	35	SURR_20_NEOX_CINEMA	72	THX_20_PLIIX_GAME	B1	THX_20_PLII_SLCT2_GAME	F1	TESTTONE
12	NORMAL_LMD_END	36	SURR_20_NEOX_MUSIC	73	THX_20_PLIIZ_GAME	B2	THX_20_PLIIZ_SLCT2_GAME	F2	TESTTHR
		37	SURR_20_NEOX_GAME	74	THX_20_NEURAL_GAMES	B3	THX_51_SLCT2_GAM	F3	TESTAUTO
		38	SURR_51_NEOX_CINEMA	75	THX_51_OFF_GAMES	B4	THX_51_PLIIZ_SLCT2_GAME	F4	ASC
		39	SURR_51_NEOX_MUSIC	76	THX_51_MTR_GAMES	B5	THX_U2GAME_LMD_END	F5	FLASH
		40	SURR_51_NEOX_GAME	77	THX_51_DSC_GAMES			F6	DEBUGMODE
		41	SURR_20_DOLBY_SURR	78	THX_51_PLIIX_GAME	B6	THX_U2MUSIC_LMD_BEGIN	F7	FLASH2
		42	SURR_51_DOLBY_SURR	79	THX_51_PLIIZ_GAMES	B7	THX_51_SLCT2_MUS	F8	FLASH3
		43	SURR_LMD_END	7A	THX_51_NEO6_GAMES	B8	THX_51_PLIIZ_SLCT2_MUSIC	F9	FLASH4
				7B	THX_51_NEURAL_GAMES	B9	THX_U2MUSIC_LMD_END	FA	FLASH_CHECK
		48	DTSSS_LMD_BEGIN	7C	THX_20_NEOX_GAMES	BA	THX_U2CINEMA_LMD_BEGIN	FB	SPECIAL_LMD_END
		49	DTSSS_20_NEO6_MUSIC	7D	THX_51_NEOX_GAMES	BB	THX_51_SLCT2_CIN		
		4A	DTSSS_20_NEO6_CINEMA	7E	THX_20_DOLBY_SURR_GAME	BC	THX_51_PLIIZ_SLCT2_CINEMA		
		4B	DTSSS_51	7F	THX_51_DOLBY_SURR_GAME	BD	THX_U2CINEMA_LMD_END		
		4C	DTSSS_LMD_END	80	THX_GAME_LMD_END				

TX-NR555/NR656
HT-R695
TX-RZ610
DRX-2/3

TX-NR555(B)MDC**<Note>**

Parts marked by "NSP" are generally unavailable because they are not in our Master Spare Parts List.

NOTE : THE COMPONENTS IDENTIFIED BY THE MARK ! ARE CRITICAL FOR RISK OF FIRE AND ELECTRIC SHOCK. REPLACE ONLY WITH PART

<Notes>

█ : NSP

<MDC> : 120V

Canadian/USA/(Mexico) model

REF. NO.	PART NAME	DESCRIPTION	Q'TY	PART NO. (SN)	REMARKS
[Cabinet, Chassis, Screws, Nuts]					
A001	CHASSIS	TX-NR555	1	27100602	N NSP
A002	LEG	(B)	4	27175464	
A004	CUSHION	(ZUL)	4	28141877	NSP
A005	SCREW	3TTB+8B(3BC)	4	838430088GR	NSP
A006	HOLDER	(CPS-8)	2	27191383	N NSP
A006or	HOLDER	KGLS-8RT	(2)	27190503A	NSP
A007	HOLDER	(NPS-8)	2	27191387	N NSP
A007or	HOLDER	KGPS-8RF	(2)	27191044	NSP
A010	HOLDER	(NPS-14)	2	27191388	N NSP
A010or	HOLDER	KGPS-14RF	(2)	27190802	NSP
A012	HOLDER	(CPS-12)	1	27191385	N NSP
A012or	HOLDER	KGLS-12RT	(1)	27190266	NSP
A014	HOLDER	(PGS-22)	3	27191382	N NSP
A014or	HOLDER	KGLS-22S	(3)	27190369	NSP
A015	HOLDER	PGS-26	1	27191405	N NSP
A016	HEAT SINK	TX-NR656	1	27160703	N NSP
A017	RETAINER	(HR)TX-NR656	1	27142349	N NSP
A018	RETAINER	(HL)TX-NR656	1	27142350	N NSP
A019	SCREW	3SMS8W.SW+14B(CU)	14	801634	NSP
A020	SCREW	3TTB+8B(3BC)	4	838430088GR	NSP
A021	SCREW	3TTB+8B(3BC)	1	838430088GR	NSP
A022	SCREW	3TTB+8B(3BC)	2	838430088GR	NSP
A023	SCREW	3TTB+8B(3BC)	2	838430088GR	NSP
A024	RETAINER	(B)	1	27142141A	N NSP
A025	SCREW	3TTB+8B(3BC)	2	838430088GR	NSP
A026	SCREW	3TTB+8B(3BC)	2	838430088GR	NSP
A027	SCREW	3TTB+8B(3BC)	3	838430088GR	NSP
A028	SCREW	3TTB+8B(3CM)SR	2	801637	NSP
A029	RETAINER	(PS)TX-NR656	1	27142351	N NSP
A030	SCREW	3TTB+8B(3BC)	3	838430088GR	NSP
A031	SCREW	4TTC+8C(3BC)SR	4	801658	NSP
A032	HOLDER	(ANNTENA-1)	1	27191416	N NSP
A033	HOLDER	(ANNTENA-2)	1	27191417	N NSP
A035	HOLDER	(PRC)	1	27191419A	N NSP
A036	LABEL	SHEET(S)	1	29364983	
A036A	LABEL	(E-CON)	{1}	29364978	N
A037	WIRE TIE	BSK-1	5	260208	NSP
A038	TAPE	TAPE(CLOTH-16U)	0.1	29110083	NSP
A039	RETAINER	(HDMI)TX-NR656	1	27142352	N NSP
A040	SCREW	3TTB+8B(3BC)	2	838430088GR	NSP
A050	HOLDER	(PLUG)	1	27191418A	N NSP
A051	SCREW	2B+5FN(3CM)	1	82512005	N NSP
A052	WS CLAMP	CLAMP WS-2W	1	27300243	N NSP
A101	REAR PANEL	555MDC	1	27124714	N

A102	SCREW	3TTB+8B(3BC)	29	838430088GR	NSP
A103	SCREW	3P+6FN(3BC)	7	82143006GR	NSP
A104	CUSHION	.	2	28141799	NSP
A105	SCREW	3TTB+8B(3CM)SR	1	801637	NSP
A106	WASHER	W3*10F(3BC)	1	87643010GR	N NSP
A107	BUSHING	S-RELIEF #2271	1	27300750	! NSP
A109	LABEL	SP(9ch)_onk	1	29393160A	N
A110	TAPE	TAPE(CLOTH-8U)	0.02	29110082	NSP
A201	FRONT PANEL	TXNR555(B)DC	1	27213828A	N
A202	BADGE	.	1	28135317	
A203	CLEAR PLATE	TXNR555(B)DC	1	28192470	N
A204	KNOB	(STBY)TX-NR555(B)	1	28327261	N
A205	KNOB	(SEL)TX-NR555	1	28327260	N
A206	KNOB	(INP)TX-NR555(B)	1	28327258	N
A208	KNOB	(VOL)AS_TX-NR555(B)	1	28327270	N
A208A	SPRING	.	{1}	27180575	
A209	KNOB	(TONE)AS_TX-NR555(B)	1	28327250	N
A209A	SPRING	.	{1}	27180575	
A210	KNOB	(TONE)AS_TX-NR555(B)	1	28327250	N
A210A	SPRING	.	{1}	27180575	
A211	KNOB	(CUR)	1	28326907B	
A221	SCREW	2.6TTB+8B(3BC)	17	838426088GR	NSP
A222	SCREW	3TTB+8B(3BC)	6	838430088GR	NSP
A401	COVER	TXNR555(B) (Bent)	1	28210149	N
A401	COVER	TXNR555(B) (Not Bent)	1	28210149Z	N
A402	SCREW	3TTB+8B(3BC)	8	838430088GR	NSP
A403	CUSHION	(FELT)t1x20x10	4	28141859	NSP
A404	LABEL	(CAUTION)	1	29392531	N
A409	LABEL	POP(TX-NR555DC)	<<1>>	29393182	N
[Semi-conductors]					
Q6001	TRANSISTOR	2SC5198-O	1	2203063	
Q6001or	TRANSISTOR	2SC5198-R	(1)	2203062	
Q6001or	TRANSISTOR	2SC4468-P	(1)	2202526	
Q6001or	TRANSISTOR	2SC4468-O	(1)	2202523	
Q6001A	ISO SHEET	AC238	2	223024	
Q6001B	ISO SHEET	ISO SHEET	6	223050	
Q6002	TRANSISTOR	2SC5198-O	1	2203063	
Q6002or	TRANSISTOR	2SC5198-R	(1)	2203062	
Q6002or	TRANSISTOR	2SC4468-P	(1)	2202526	
Q6002or	TRANSISTOR	2SC4468-O	(1)	2202523	
Q6003	TRANSISTOR	2SC5198-O	1	2203063	
Q6003or	TRANSISTOR	2SC5198-R	(1)	2203062	
Q6003or	TRANSISTOR	2SC4468-P	(1)	2202526	
Q6003or	TRANSISTOR	2SC4468-O	(1)	2202523	
Q6005	TRANSISTOR	2SC5198-O	1	2203063	
Q6005or	TRANSISTOR	2SC5198-R	(1)	2203062	
Q6005or	TRANSISTOR	2SC4468-P	(1)	2202526	
Q6005or	TRANSISTOR	2SC4468-O	(1)	2202523	
Q6006	TRANSISTOR	2SC5198-O	1	2203063	
Q6006or	TRANSISTOR	2SC5198-R	(1)	2203062	
Q6006or	TRANSISTOR	2SC4468-P	(1)	2202526	
Q6006or	TRANSISTOR	2SC4468-O	(1)	2202523	
Q6007	TRANSISTOR	2SC5198-O	1	2203063	
Q6007or	TRANSISTOR	2SC5198-R	(1)	2203062	
Q6007or	TRANSISTOR	2SC4468-P	(1)	2202526	

Q6007or	TRANSISTOR	2SC4468-O	(1)	2202523	
Q6008	TRANSISTOR	2SC5198-O	1	2203063	
Q6008or	TRANSISTOR	2SC5198-R	(1)	2203062	
Q6008or	TRANSISTOR	2SC4468-P	(1)	2202526	
Q6008or	TRANSISTOR	2SC4468-O	(1)	2202523	
Q6021	TRANSISTOR	2SA1941-O	1	2203053	
Q6021or	TRANSISTOR	2SA1941-R	(1)	2203052	
Q6021or	TRANSISTOR	2SA1695-P	(1)	2202516	
Q6021or	TRANSISTOR	2SA1695-O	(1)	2202513	
Q6022	TRANSISTOR	2SA1941-O	1	2203053	
Q6022or	TRANSISTOR	2SA1941-R	(1)	2203052	
Q6022or	TRANSISTOR	2SA1695-P	(1)	2202516	
Q6022or	TRANSISTOR	2SA1695-O	(1)	2202513	
Q6023	TRANSISTOR	2SA1941-O	1	2203053	
Q6023or	TRANSISTOR	2SA1941-R	(1)	2203052	
Q6023or	TRANSISTOR	2SA1695-P	(1)	2202516	
Q6023or	TRANSISTOR	2SA1695-O	(1)	2202513	
Q6025	TRANSISTOR	2SA1941-O	1	2203053	
Q6025or	TRANSISTOR	2SA1941-R	(1)	2203052	
Q6025or	TRANSISTOR	2SA1695-P	(1)	2202516	
Q6025or	TRANSISTOR	2SA1695-O	(1)	2202513	
Q6026	TRANSISTOR	2SA1941-O	1	2203053	
Q6026or	TRANSISTOR	2SA1941-R	(1)	2203052	
Q6026or	TRANSISTOR	2SA1695-P	(1)	2202516	
Q6026or	TRANSISTOR	2SA1695-O	(1)	2202513	
Q6027	TRANSISTOR	2SA1941-O	1	2203053	
Q6027or	TRANSISTOR	2SA1941-R	(1)	2203052	
Q6027or	TRANSISTOR	2SA1695-P	(1)	2202516	
Q6027or	TRANSISTOR	2SA1695-O	(1)	2202513	
Q6028	TRANSISTOR	2SA1941-O	1	2203053	
Q6028or	TRANSISTOR	2SA1941-R	(1)	2203052	
Q6028or	TRANSISTOR	2SA1695-P	(1)	2202516	
Q6028or	TRANSISTOR	2SA1695-O	(1)	2202513	
[Transformers, Coils]					
T901	POWER TRANSFORMER	NPT-1664D	1	2302142	!, N
[Switches, Terminals, Wires]					
F6901	FUSE	10A-UL/T-233	1	252330GR	!, N
F6901or	FUSE	10A-T/UL-ST2	(1)	252333GR	!
F6901E	FUSE LABEL	10A/125V	1	29362241	! NSP
F6902	FUSE	10A-UL/T-233	1	252330GR	!, N
F6902or	FUSE	10A-T/UL-ST2	(1)	252333GR	!
F9002	FUSE	8A-UL/T-233	1	252329GR	!, N
F9002or	FUSE	8A-T/UL-ST2	(1)	252261GR	!
F9002E	LABEL	8A/125V	1	29360842	
P101	FLEXIBLE FLAT CABLE	NCFC7-071012	1	2047071012	N
P2800	FLEXIBLE FLAT CABLE	NCFC5-231012	1	2045231012	N
P3654A	ASSEMBLED PWB	WCBN806L	1	24150135	N
P3654B	WIFI BT ANTENNA	RFDPA870918EMLB302	1	2050102	N
P3654C	WIFI BT ANTENNA	RFDPA870940EMLB303	1	2050103	N
P7001	FLEXIBLE FLAT CABLE	NCFC5-313012	1	2045313012	N
P9001	POWER SUPPLY CORD	AS-UC-2	1	253368AYUN	!
P9001or	POWER SUPPLY CORD	AS-UC-2	(1)	253368BLTK	!
[Frontend, Units]					
U010	PARENT PC BOARD AS	BAAF-1979-1A-P	1	1B5141979-1A	Parent
BAAF-1979	Audio frequency circuit pc board AS	BAAF-1979-1A	1	1B5141979-1A-C	Child

BAETC-1980	Et cetra pc board AS	BAETC-1980-1A	1	1B5141980-1A-C	Child
BAETC-1981	Et cetra pc board AS	BAETC-1981-1A	1	1B5141981-1A-C	Child
U020	PARENT PC BOARD AS	BADIS-1983-1A-P	1	1B5141983-1A	Parent
BADIS-1983	Display circuit pc board AS	BADIS-1983-1A	1	1B5141983-1A-C	Child
BAPS-1984	Power supply circuit pc board AS	BAPS-1984-1A	1	1B5141984-1A-C	Child
BADG-1985	Digital circuit pc board AS	BADG-1985-1A	1	1B5141985-1A-C	Child
BAETC-1986	Et cetra pc board AS	BAETC-1986-1A	1	1B5141986-1A-C	Child
BARF-1987	Radio frequency circuit pc board AS	BARF-1987-1A	1	1B5141987-1A-C	Child
BACLA-1988	ClassA amplifier circuit pc board AS	BACLA-1988-1A	1	1B5141988-1A-C	Child
BASW-1989	Switch circuit pc board AS	BASW-1989-1A	1	1B5141989-1A-C	Child
U020A	SHIELD CASE	(UPPER)	1	27225208	N
U020B	SHIELD CASE	(TUNER-BTM)	1	27225207A	N
U030	PARENT PC BOARD AS	BATRM-2023-1A-P	1	1B5142023-1A	Parent
BATRM-2023	Terminal circuit pc board AS	BATRM-2023-1A	1	1B5142023-1A-C	Child
BAETC-2024	Et cetra pc board AS	BAETC-2024-1A	1	1B5142024-1A-C	Child
BAETC-2025	Et cetra pc board AS	BAETC-2025-1A	1	1B5142025-1A-C	Child
BAETC-2026	Et cetra pc board AS	BAETC-2026-1A	1	1B5142026-1A-C	Child
BAETC-2027	Et cetra pc board AS	BAETC-2027-1A	1	1B5142027-1A-C	Child
U040	PARENT PC BOARD AS	BAPRC-2034-1A-P	1	1B5142034-1A555MDC	Parent
BAPRC-2034	Processing circuit pc board AS	BAPRC-2034-1A	1	1B5142034-1A-C555MDC	Child
[Packing]					
A501	PAD	(AS)TXNR656	1	29092736	N
A501A	PAD	(L)TXNR656	{1}	29092737	N
A501B	PAD	(R)TXNR656	{1}	29092738	N
A502	SHEET	1300*650	1	29096147	N
A503	TAPE	(SEROHAN)NITTO NO.29	0.3	29110149	NSP
A504	CARTON	TXNR555DC	1	29055587	N
A505	POLYPROPYLENE TAPE	W50 SBT-70	2	29110200	NSP
A506A	UPC LABEL	TXNR555MDC	{1}	29393020	N
A515	LABEL	(DTSX)	1	29392958	N
[Accessories]					
A801	POLY BAG	w250xd350	1	29100250A	NSP
A802	TAPE	(SEROHAN)NITTO NO.29	0.2	29110149	NSP
A803	REMOTE CONTROL TRANSMITTER	RC-911R	1	24140911	N
A804	BATTERY	R03/AAA(UM-4)	2	3010124	
A805	MIC	KHM0028-010020	1	245048A	N
A806	ANTENNA COIL	AM LOOP-ANTENNA	1	232207	N
A807	FM ANT AS	Type W	1	292191	
A815	WARRANTY CARD	(ONKYO)	1	29365156	N
A901	INSTRUCTION MANUAL	En(TXNR555)_BAS	1	29402159	N
A902	INSTRUCTION MANUAL	U2FrEs(TXNR555)_BAS	1	29402160	N
A910	INSTRUCTION MANUAL	SAFETY_ONK_U4(EnFrEsCt)(;	1	29402334	N
A912	SHEET	(FLYER-US AVR 2015)	1	29380164	N
A913	INSTRUCTION SHEET	(internet radio-2016)	1	29355957	N

BAAF-1979-1A**<Note>**

Parts marked by "NSP" are generally unavailable because they are not in our Master Spare Parts List.

<Notes>

█ : NSP

NOTE : THE COMPONENTS IDENTIFIED BY THE MARK ! ARE CRITICAL FOR RISK OF FIRE AND ELECTRIC SHOCK. REPLACE ONLY WITH PART

REF. NO.	PART NAME	DESCRIPTION	Q'TY	PART NO. (SN)	REMARKS
[Semi-conductors]					
D4217	CHIP TYPE DIODE	DA2J10100	1	223303R2	NSP
D4218	CHIP TYPE DIODE	DA2J10100	1	223303R2	NSP
D4251	DIODE	RL1N4003	1	22380260T	NSP
D4252	DIODE	RL1N4003	1	22380260T	NSP
D4253	DIODE	RL1N4003	1	22380260T	NSP
D4254	DIODE	RL1N4003	1	22380260T	NSP
D4255	CHIP TYPE DIODE	DA2J10100	1	223303R2	NSP
D4256	CHIP TYPE DIODE	DA2J10100	1	223303R2	NSP
D4259	ZENER DIODE	DZ2J068M0L	1	224760680R2	NSP
D4260	ZENER DIODE	DZ2J068M0L	1	224760680R2	NSP
D5085	ZENER DIODE	DZ2J056M0L	1	224760560R2	NSP
D5085or	ZENER DIODE	UDZS5.6B	(1)	224550560R2	NSP
D5086	ZENER DIODE	DZ2J056M0L	1	224760560R2	NSP
D5086or	ZENER DIODE	UDZS5.6B	(1)	224550560R2	NSP
D5087	ZENER DIODE	DZ2J056M0L	1	224760560R2	NSP
D5087or	ZENER DIODE	UDZS5.6B	(1)	224550560R2	NSP
D5088	ZENER DIODE	DZ2J056M0L	1	224760560R2	NSP
D5088or	ZENER DIODE	UDZS5.6B	(1)	224550560R2	NSP
D6601	CHIP TYPE DIODE	DA2J10100	1	223303R2	NSP
D6601or	CHIP TYPE DIODE	1SS352	(1)	223234R2	NSP
D6602	CHIP TYPE DIODE	DA2J10100	1	223303R2	NSP
D6602or	CHIP TYPE DIODE	1SS352	(1)	223234R2	NSP
D6603	CHIP TYPE DIODE	DA2J10100	1	223303R2	NSP
D6603or	CHIP TYPE DIODE	1SS352	(1)	223234R2	NSP
D6605	CHIP TYPE DIODE	DA2J10100	1	223303R2	NSP
D6605or	CHIP TYPE DIODE	1SS352	(1)	223234R2	NSP
D6606	CHIP TYPE DIODE	DA2J10100	1	223303R2	NSP
D6606or	CHIP TYPE DIODE	1SS352	(1)	223234R2	NSP
D6607	CHIP TYPE DIODE	DA2J10100	1	223303R2	NSP
D6607or	CHIP TYPE DIODE	1SS352	(1)	223234R2	NSP
D6608	CHIP TYPE DIODE	DA2J10100	1	223303R2	NSP
D6608or	CHIP TYPE DIODE	1SS352	(1)	223234R2	NSP
D6621	CHIP TYPE DIODE	DA2J10100	1	223303R2	NSP
D6621or	CHIP TYPE DIODE	1SS352	(1)	223234R2	NSP
D6622	CHIP TYPE DIODE	DA2J10100	1	223303R2	NSP
D6622or	CHIP TYPE DIODE	1SS352	(1)	223234R2	NSP
D6623	CHIP TYPE DIODE	DA2J10100	1	223303R2	NSP
D6623or	CHIP TYPE DIODE	1SS352	(1)	223234R2	NSP
D6625	CHIP TYPE DIODE	DA2J10100	1	223303R2	NSP
D6625or	CHIP TYPE DIODE	1SS352	(1)	223234R2	NSP
D6626	CHIP TYPE DIODE	DA2J10100	1	223303R2	NSP
D6626or	CHIP TYPE DIODE	1SS352	(1)	223234R2	NSP
D6627	CHIP TYPE DIODE	DA2J10100	1	223303R2	NSP
D6627or	CHIP TYPE DIODE	1SS352	(1)	223234R2	NSP

D6628	CHIP TYPE DIODE	DA2J10100	1	223303R2	NSP
D6628or	CHIP TYPE DIODE	1SS352	(1)	223234R2	NSP
D6703	ZENER DIODE	DZ2J036M0L	1	224760360R2	NSP
D6704	CHIP TYPE DIODE	DA2J10100	1	223303R2	NSP
D6705	CHIP TYPE DIODE	DA2J10100	1	223303R2	NSP
D6706	CHIP TYPE DIODE	DA2J10100	1	223303R2	NSP
D6707	ZENER DIODE	DZ2J100M0L	1	224761000R2	NSP
D6740	CHIP TYPE DIODE	DA2J10100	1	223303R2	NSP
D6741	CHIP TYPE DIODE	DA2J10100	1	223303R2	NSP
D6761	CHIP TYPE DIODE	DA2J10100	1	223303R2	NSP
D6761or	CHIP TYPE DIODE	1SS352	(1)	223234R2	NSP
D6762	CHIP TYPE DIODE	DA2J10100	1	223303R2	NSP
D6762or	CHIP TYPE DIODE	1SS352	(1)	223234R2	NSP
D6763	CHIP TYPE DIODE	DA2J10100	1	223303R2	NSP
D6763or	CHIP TYPE DIODE	1SS352	(1)	223234R2	NSP
D6765	CHIP TYPE DIODE	DA2J10100	1	223303R2	NSP
D6765or	CHIP TYPE DIODE	1SS352	(1)	223234R2	NSP
D6766	CHIP TYPE DIODE	DA2J10100	1	223303R2	NSP
D6766or	CHIP TYPE DIODE	1SS352	(1)	223234R2	NSP
D6767	CHIP TYPE DIODE	DA2J10100	1	223303R2	NSP
D6767or	CHIP TYPE DIODE	1SS352	(1)	223234R2	NSP
D6768	CHIP TYPE DIODE	DA2J10100	1	223303R2	NSP
D6768or	CHIP TYPE DIODE	1SS352	(1)	223234R2	NSP
D6780	ZENER DIODE	DZ2J033M0L	1	224760330R2	NSP
D6901	DIODE	TS10B06G-07	1	22380379	N
D6901A	HEAT SINK	RAD-196	1	27160545	NSP
D6901B	SCREW	3P+10FN(3BC)	1	82143010GR	NSP
D6911	CHIP TYPE DIODE	DA2J10100	1	223303R2	NSP
D6911or	CHIP TYPE DIODE	1SS352	(1)	223234R2	NSP
Q4001	HYBRID IC	BD34704KS2	1	22242977R3	N
Q4004	HYBRID IC	NJM4580CG	1	22242922R2	N NSP
Q4008	HYBRID IC	NJM4580CG	1	22242922R2	N NSP
Q4101	TRANSISTOR	RTAN430C-T112-1	1	2217780R2	NSP
Q4102	TRANSISTOR	RTAN430C-T112-1	1	2217780R2	NSP
Q4103	TRANSISTOR	RTAN430C-T112-1	1	2217780R2	NSP
Q4104	TRANSISTOR	RTAN430C-T112-1	1	2217780R2	NSP
Q4105	TRANSISTOR	RTAN430C-T112-1	1	2217780R2	NSP
Q4106	TRANSISTOR	RTAN430C-T112-1	1	2217780R2	NSP
Q4107	TRANSISTOR	RTAN430C-T112-1	1	2217780R2	NSP
Q4108	TRANSISTOR	RTAN430C-T112-1	1	2217780R2	NSP
Q4114	TRANSISTOR	RTAN430C-T112-1	1	2217780R2	NSP
Q4251	HYBRID IC	78M15HF(NJM78M15FA)	1	222780155JRC	
Q4251A	HEAT SINK	RAD-196	1	27160545	NSP
Q4251B	SCREW	3TTB+8B(3BC)	1	838430088GR	NSP
Q4252	HYBRID IC	79M15HF(NJM79M15FA)	1	222790155JRC	
Q4252B	SCREW	3TTB+8B(3BC)	1	838430088GR	NSP
Q4301	TRANSISTOR	RTAN430C-T112-1	1	2217780R2	NSP
Q4302	TRANSISTOR	RTAN430C-T112-1	1	2217780R2	NSP
Q4530	HYBRID IC	NJM4580CG	1	22242922R2	N NSP
Q5105	TRANSISTOR	2SC2713-BL	1	2213136R2	
Q5106	TRANSISTOR	2SC2713-BL	1	2213136R2	
Q5107	TRANSISTOR	2SC2713-BL	1	2213136R2	
Q5108	TRANSISTOR	2SC2713-BL	1	2213136R2	
Q5125	TRANSISTOR	2SC2713-BL	1	2213136R2	
Q5126	TRANSISTOR	2SC2713-BL	1	2213136R2	

Q5127	TRANSISTOR	2SC2713-BL	1	2213136R2	
Q5128	TRANSISTOR	2SC2713-BL	1	2213136R2	
Q5225	TRANSISTOR	INC5001AP1-T111	1	2218100R2	N
Q5225or	TRANSISTOR	2SC2881-Y	(1)	2217564AR2	
Q5226	TRANSISTOR	INC5001AP1-T111	1	2218100R2	N
Q5226or	TRANSISTOR	2SC2881-Y	(1)	2217564AR2	
Q5227	TRANSISTOR	INC5001AP1-T111	1	2218100R2	N
Q5227or	TRANSISTOR	2SC2881-Y	(1)	2217564AR2	
Q5228	TRANSISTOR	INC5001AP1-T111	1	2218100R2	N
Q5228or	TRANSISTOR	2SC2881-Y	(1)	2217564AR2	
Q5385	TRANSISTOR	INA6006AP1-T111	1	2217980R2	N
Q5385or	TRANSISTOR	2SA1200-Y(2LONK_ZE)	(1)	2217584R2	
Q5386	TRANSISTOR	INA6006AP1-T111	1	2217980R2	N
Q5386or	TRANSISTOR	2SA1200-Y(2LONK_ZE)	(1)	2217584R2	
Q5387	TRANSISTOR	INA6006AP1-T111	1	2217980R2	N
Q5387or	TRANSISTOR	2SA1200-Y(2LONK_ZE)	(1)	2217584R2	
Q5388	TRANSISTOR	INA6006AP1-T111	1	2217980R2	N
Q5388or	TRANSISTOR	2SA1200-Y(2LONK_ZE)	(1)	2217584R2	
Q5405	TRANSISTOR	INC6006AP1-T111	1	2217990R2	N
Q5405or	TRANSISTOR	2SC2880-Y(2LONK_ZE)	(1)	2217594R2	
Q5406	TRANSISTOR	INC6006AP1-T111	1	2217990R2	N
Q5406or	TRANSISTOR	2SC2880-Y(2LONK_ZE)	(1)	2217594R2	
Q5407	TRANSISTOR	INC6006AP1-T111	1	2217990R2	N
Q5407or	TRANSISTOR	2SC2880-Y(2LONK_ZE)	(1)	2217594R2	
Q5408	TRANSISTOR	INC6006AP1-T111	1	2217990R2	N
Q5408or	TRANSISTOR	2SC2880-Y(2LONK_ZE)	(1)	2217594R2	
Q5601	TRANSISTOR	2SD2704K	1	2218130R2	N
Q5602	TRANSISTOR	2SD2704K	1	2218130R2	N
Q5603	TRANSISTOR	2SD2704K	1	2218130R2	N
Q5605	TRANSISTOR	2SD2704K	1	2218130R2	N
Q5606	TRANSISTOR	2SD2704K	1	2218130R2	N
Q5607	TRANSISTOR	2SD2704K	1	2218130R2	N
Q5608	TRANSISTOR	2SD2704K	1	2218130R2	N
Q5625	TRANSISTOR	2SC2713-BL	1	2213136R2	
Q5626	TRANSISTOR	2SC2713-BL	1	2213136R2	
Q5627	TRANSISTOR	2SC2713-BL	1	2213136R2	
Q5628	TRANSISTOR	2SC2713-BL	1	2213136R2	
Q5645	TRANSISTOR	2SA1163-BL	1	2216756R2	
Q5646	TRANSISTOR	2SA1163-BL	1	2216756R2	
Q5647	TRANSISTOR	2SA1163-BL	1	2216756R2	
Q5648	TRANSISTOR	2SA1163-BL	1	2216756R2	
Q6105	TRANSISTOR	TTC004B_Q(S	1	2218022	N
Q6106	TRANSISTOR	TTC004B_Q(S	1	2218022	N
Q6107	TRANSISTOR	TTC004B_Q(S	1	2218022	N
Q6108	TRANSISTOR	TTC004B_Q(S	1	2218022	N
Q6125	TRANSISTOR	TTA004B_Q(S	1	2218012	N
Q6126	TRANSISTOR	TTA004B_Q(S	1	2218012	N
Q6127	TRANSISTOR	TTA004B_Q(S	1	2218012	N
Q6128	TRANSISTOR	TTA004B_Q(S	1	2218012	N
Q6601	TRANSISTOR	INC6002AC1	1	2218840R2	N
Q6602	TRANSISTOR	INC6002AC1	1	2218840R2	N
Q6603	TRANSISTOR	INC6002AC1	1	2218840R2	N
Q6605	TRANSISTOR	INC6002AC1	1	2218840R2	N
Q6606	TRANSISTOR	INC6002AC1	1	2218840R2	N
Q6607	TRANSISTOR	INC6002AC1	1	2218840R2	N

Q6608	TRANSISTOR	INC6002AC1	1	2218840R2	N
Q6700	TRANSISTOR	2SA1163-BL	1	2216756R2	NSP
Q6705	TRANSISTOR	2SC2713-BL	1	2213136R2	NSP
Q6706	TRANSISTOR	KRA102S	1	2216220R2	NSP
Q6706or	TRANSISTOR	RN2402	(1)	2214530R2	NSP
Q6740	TRANSISTOR	2SC2713-BL	1	2213136R2	NSP
Q6741	TRANSISTOR	2SC2713-BL	1	2213136R2	NSP
Q6742	TRANSISTOR	2SA1163-BL	1	2216756R2	NSP
Q6800	HYBRID IC	LM61CIZ	1	22242212	
Q6800A	RETAINER	(PTH)	1	27141884-1	NSP
Q6801	TRANSISTOR	2SC2712-GR	1	2213145R2	NSP
Q6802	TRANSISTOR	2SA1162-GR	1	2214375R2	NSP
Q6911	TRANSISTOR	KRC105S	1	2217290R2	NSP
Q6911or	TRANSISTOR	RN1405	(1)	2214500R2	NSP
[Transformers, Coils]					
L6441	SPEAKER OUTPUT FILTER COIL	SC2-0.8X5.5X18.5T	1	231455S	N
L6441or	SPEAKER OUTPUT FILTER COIL	SC-0.8X5.5X18.5T	(1)	231431S	
L6442	SPEAKER OUTPUT FILTER COIL	SC2-0.8X5.5X18.5T	1	231455S	N
L6442or	SPEAKER OUTPUT FILTER COIL	SC-0.8X5.5X18.5T	(1)	231431S	
L6443	SPEAKER OUTPUT FILTER COIL	SC2-0.8X5.5X18.5T	1	231455S	N
L6443or	SPEAKER OUTPUT FILTER COIL	SC-0.8X5.5X18.5T	(1)	231431S	
L6445	SPEAKER OUTPUT FILTER COIL	SC2-0.8X5.5X18.5T	1	231455S	N
L6445or	SPEAKER OUTPUT FILTER COIL	SC-0.8X5.5X18.5T	(1)	231431S	
L6446	SPEAKER OUTPUT FILTER COIL	SC2-0.8X5.5X18.5T	1	231455S	N
L6446or	SPEAKER OUTPUT FILTER COIL	SC-0.8X5.5X18.5T	(1)	231431S	
L6447	SPEAKER OUTPUT FILTER COIL	SC2-0.8X5.5X18.5T	1	231455S	N
L6447or	SPEAKER OUTPUT FILTER COIL	SC-0.8X5.5X18.5T	(1)	231431S	
L6448	SPEAKER OUTPUT FILTER COIL	SC2-0.8X5.5X18.5T	1	231455S	N
L6448or	SPEAKER OUTPUT FILTER COIL	SC-0.8X5.5X18.5T	(1)	231431S	
[Capacitors]					
C4001	CHIP TYPE CERAMIC CAPACITOR	CC725CH1H-221J1	1	342102214R1	NSP
C4002	CHIP TYPE CERAMIC CAPACITOR	CC725CH1H-221J1	1	342102214R1	NSP
C4003	CHIP TYPE CERAMIC CAPACITOR	CC725CH1H-221J1	1	342102214R1	NSP
C4004	CHIP TYPE CERAMIC CAPACITOR	CC725CH1H-221J1	1	342102214R1	NSP
C4005	CHIP TYPE CERAMIC CAPACITOR	CC725CH1H-221J1	1	342102214R1	NSP
C4006	CHIP TYPE CERAMIC CAPACITOR	CC725CH1H-221J1	1	342102214R1	NSP
C4007	CHIP TYPE CERAMIC CAPACITOR	CC725CH1H-221J1	1	342102214R1	NSP
C4008	CHIP TYPE CERAMIC CAPACITOR	CC725CH1H-221J1	1	342102214R1	NSP
C4009	UPZ TYPE PLASTIC FILM CAPACITOR	2AUPZTF221JE	1	376332214T	NSP
C4010	UPZ TYPE PLASTIC FILM CAPACITOR	2AUPZTF221JE	1	376332214T	NSP
C4011	CHIP TYPE CERAMIC CAPACITOR	CC725CH1H-221J1	1	342102214R1	NSP
C4012	CHIP TYPE CERAMIC CAPACITOR	CC725CH1H-221J1	1	342102214R1	NSP
C4015	CHIP TYPE CERAMIC CAPACITOR	CC725CH1H-221J1	1	342102214R1	NSP
C4016	CHIP TYPE CERAMIC CAPACITOR	CC725CH1H-221J1	1	342102214R1	NSP
C4041	UTSP TYPE ELECTROLYTIC CAPACITOR	CE04W50V 47M(UTSP)	1	397584707AT	N
C4042	UTSP TYPE ELECTROLYTIC CAPACITOR	CE04W50V 47M(UTSP)	1	397584707AT	N
C4043	UTSP TYPE ELECTROLYTIC CAPACITOR	CE04W50V 47M(UTSP)	1	397584707AT	N
C4044	UTSP TYPE ELECTROLYTIC CAPACITOR	CE04W50V 47M(UTSP)	1	397584707AT	N
C4045	UTSP TYPE ELECTROLYTIC CAPACITOR	CE04W25V-47M(UTSP)	1	397554707AT	N
C4046	UTSP TYPE ELECTROLYTIC CAPACITOR	CE04W25V-47M(UTSP)	1	397554707AT	N
C4047	UTSP TYPE ELECTROLYTIC CAPACITOR	CE04W25V-47M(UTSP)	1	397554707AT	N
C4048	UTSP TYPE ELECTROLYTIC CAPACITOR	CE04W25V-47M(UTSP)	1	397554707AT	N
C4049	UTSP TYPE ELECTROLYTIC CAPACITOR	CE04W50V 47M(UTSP)	1	397584707AT	N
C4050	UTSP TYPE ELECTROLYTIC CAPACITOR	CE04W50V 47M(UTSP)	1	397584707AT	N
C4051	UTSP TYPE ELECTROLYTIC CAPACITOR	CE04W50V 47M(UTSP)	1	397584707AT	N

C4052	UTSP TYPE ELECTROLYTIC CAPACITOR	CE04W50V 47M(UTSP)	1	397584707AT	N
C4053	CHIP TYPE CERAMIC CAPACITOR	CK725B1H-102K1	1	332101025R1	NSP
C4054	CHIP TYPE CERAMIC CAPACITOR	CK725B1H-102K1	1	332101025R1	NSP
C4061	CHIP TYPE CERAMIC CAPACITOR	CC725CH1H-101J1	1	342101014R1	NSP
C4062	CHIP TYPE CERAMIC CAPACITOR	CC725CH1H-101J1	1	342101014R1	NSP
C4063	UTSP TYPE ELECTROLYTIC CAPACITOR	CE04W25V-47M(UTSP)	1	397554707AT	N
C4064	UTSP TYPE ELECTROLYTIC CAPACITOR	CE04W25V-47M(UTSP)	1	397554707AT	N
C4101	UTSP TYPE ELECTROLYTIC CAPACITOR	CE04W50V 47M(UTSP)	1	397584707AT	N
C4102	UTSP TYPE ELECTROLYTIC CAPACITOR	CE04W50V 47M(UTSP)	1	397584707AT	N
C4103	UTSP TYPE ELECTROLYTIC CAPACITOR	CE04W50V 47M(UTSP)	1	397584707AT	N
C4104	UTSP TYPE ELECTROLYTIC CAPACITOR	CE04W50V-22M(UTSP)	1	397582207AT	N
C4105	UTSP TYPE ELECTROLYTIC CAPACITOR	CE04W50V 47M(UTSP)	1	397584707AT	N
C4106	UTSP TYPE ELECTROLYTIC CAPACITOR	CE04W50V 47M(UTSP)	1	397584707AT	N
C4107	UTSP TYPE ELECTROLYTIC CAPACITOR	CE04W50V 47M(UTSP)	1	397584707AT	N
C4108	UTSP TYPE ELECTROLYTIC CAPACITOR	CE04W50V 47M(UTSP)	1	397584707AT	N
C4114	CHIP TYPE CERAMIC CAPACITOR	CC725CH1H-221J1	1	342102214R1	NSP
C4175	JAMICON TYPE ELECTROLYTIC CAPACITC	CE04W16V-220M	1	398542217T	
C4176	JAMICON TYPE ELECTROLYTIC CAPACITC	CE04W16V-220M	1	398542217T	
C4181	FILM C	C281H104J20A21A	1	376821044T	N NSP
C4190	UTSP TYPE ELECTROLYTIC CAPACITOR	CE04W50V 47M(UTSP)	1	397584707AT	N
C4191	CHIP TYPE CERAMIC CAPACITOR	CC725CH1H-221J1	1	342102214R1	NSP
C4192	CHIP TYPE CERAMIC CAPACITOR	CK725B1H-103K1	1	332101035R1	NSP
C4203	CHIP TYPE CERAMIC CAPACITOR	CK725B1H-102K1	1	332101025R1	NSP
C4204	CHIP TYPE CERAMIC CAPACITOR	CK725B1H-102K1	1	332101025R1	NSP
C4206	CHIP TYPE CERAMIC CAPACITOR	CK725B1H-102K1	1	332101025R1	NSP
C4207	CHIP TYPE CERAMIC CAPACITOR	CK725B1H-102K1	1	332101025R1	NSP
C4208	CHIP TYPE CERAMIC CAPACITOR	CK725B1H-102K1	1	332101025R1	NSP
C4209	CHIP TYPE CERAMIC CAPACITOR	CK725B1H-102K1	1	332101025R1	NSP
C4214	CHIP TYPE CERAMIC CAPACITOR	CK725B1H-103K1	1	332101035R1	NSP
C4250	FILM C	C282A334J20A21A	1	376833344T	N NSP
C4251	JAMICON TYPE ELECTROLYTIC CAPACITC	CE04W35V-1000M	1	398561027T	
C4252	JAMICON TYPE ELECTROLYTIC CAPACITC	CE04W35V-1000M	1	398561027T	
C4253	FILM C	C281H104J20A21A	1	376821044T	N NSP
C4254	FILM C	C281H104J20A21A	1	376821044T	N NSP
C4255	JAMICON TYPE ELECTROLYTIC CAPACITC	CE04W50V-10M	1	398581007T	
C4255or	UTSP TYPE ELECTROLYTIC CAPACITOR	CE04W50V-10M(UTSP)	(1)	397581007AT	
C4256	JAMICON TYPE ELECTROLYTIC CAPACITC	CE04W50V-10M	1	398581007T	
C4256or	UTSP TYPE ELECTROLYTIC CAPACITOR	CE04W50V-10M(UTSP)	(1)	397581007AT	
C4261	JAMICON TYPE ELECTROLYTIC CAPACITC	CE04W16V-470M	1	398544717T	
C4261or	UTSP TYPE ELECTROLYTIC CAPACITOR	CE04W16V-470M(UTSP)	(1)	397544717T	
C4262	JAMICON TYPE ELECTROLYTIC CAPACITC	CE04W16V-470M	1	398544717T	
C4262or	UTSP TYPE ELECTROLYTIC CAPACITOR	CE04W16V-470M(UTSP)	(1)	397544717T	
C4269	JAMICON TYPE ELECTROLYTIC CAPACITC	CE04W10V-470M	1	398534717T	
C4269or	UTSP TYPE ELECTROLYTIC CAPACITOR	CE04W10V-470M(UTSP)	(1)	397534717T	
C4270	JAMICON TYPE ELECTROLYTIC CAPACITC	CE04W10V-470M	1	398534717T	
C4270or	UTSP TYPE ELECTROLYTIC CAPACITOR	CE04W10V-470M(UTSP)	(1)	397534717T	
C4311	UTSP TYPE ELECTROLYTIC CAPACITOR	CE04W25V-47M(UTSP)	1	397554707AT	N
C4312	UTSP TYPE ELECTROLYTIC CAPACITOR	CE04W25V-47M(UTSP)	1	397554707AT	N
C4313	CHIP TYPE CERAMIC CAPACITOR	CC725CH1H-221J1	1	342102214R1	NSP
C4314	CHIP TYPE CERAMIC CAPACITOR	CC725CH1H-221J1	1	342102214R1	NSP
C4531	ELECTROLYTIC CAPACITOR	CE04W16V-47M(S)	1	353744709T	
C4532	ELECTROLYTIC CAPACITOR	CE04W16V-47M(S)	1	353744709T	
C4533	CHIP TYPE CERAMIC CAPACITOR	CC725CH1H-102J1	1	342101024R1	NSP
C4534	CHIP TYPE CERAMIC CAPACITOR	CC725CH1H-102J1	1	342101024R1	NSP
C4535	UMXR TYPE PLASTIC FILM CAPACITOR	1JUMXR1F123JE	1	376591234T	N NSP

C4536	UMXR TYPE PLASTIC FILM CAPACITOR	1JUMXRTEF123JE	1	376591234T	N	NSP
C4537	UMXR TYPE PLASTIC FILM CAPACITOR	1JUMXRTEF332JE	1	376593324T	N	NSP
C4538	UMXR TYPE PLASTIC FILM CAPACITOR	1JUMXRTEF332JE	1	376593324T	N	NSP
C4543	CHIP TYPE CERAMIC CAPACITOR	CK725B1H-472K1	1	332104725R1		NSP
C4544	CHIP TYPE CERAMIC CAPACITOR	CK725B1H-472K1	1	332104725R1		NSP
C4545	UTSP TYPE ELECTROLYTIC CAPACITOR	CE04W50V-10M(UTSP)	1	397581007AT	N	
C4546	UTSP TYPE ELECTROLYTIC CAPACITOR	CE04W50V-10M(UTSP)	1	397581007AT	N	
C4547	JAMICON TYPE ELECTROLYTIC CAPACITC	CE04W16V-220M	1	398542217T		
C4548	JAMICON TYPE ELECTROLYTIC CAPACITC	CE04W16V-220M	1	398542217T		
C4549	CHIP TYPE CERAMIC CAPACITOR	CK725B1H-104K1	1	332101045R1	N	NSP
C4550	CHIP TYPE CERAMIC CAPACITOR	CK725B1H-104K1	1	332101045R1	N	NSP
C4551	UTSP TYPE ELECTROLYTIC CAPACITOR	CE04W10V-220M(UTSP)	1	397532217AT	N	
C4552	UTSP TYPE ELECTROLYTIC CAPACITOR	CE04W10V-220M(UTSP)	1	397532217AT	N	
C5005	UPZ TYPE PLASTIC FILM CAPACITOR	2AUPZTF221JE	1	376332214T		NSP
C5006	UPZ TYPE PLASTIC FILM CAPACITOR	2AUPZTF221JE	1	376332214T		NSP
C5007	UPZ TYPE PLASTIC FILM CAPACITOR	2AUPZTF221JE	1	376332214T		NSP
C5008	UPZ TYPE PLASTIC FILM CAPACITOR	2AUPZTF221JE	1	376332214T		NSP
C5025	UTSP TYPE ELECTROLYTIC CAPACITOR	CE04W50V 47M(UTSP)	1	397584707AT	N	
C5026	UTSP TYPE ELECTROLYTIC CAPACITOR	CE04W50V 47M(UTSP)	1	397584707AT	N	
C5027	UTSP TYPE ELECTROLYTIC CAPACITOR	CE04W50V 47M(UTSP)	1	397584707AT	N	
C5028	UTSP TYPE ELECTROLYTIC CAPACITOR	CE04W50V 47M(UTSP)	1	397584707AT	N	
C5085	UTSP TYPE ELECTROLYTIC CAPACITOR	CE04W50V-10M(UTSP)	1	397581007AT	N	
C5086	UTSP TYPE ELECTROLYTIC CAPACITOR	CE04W50V-10M(UTSP)	1	397581007AT	N	
C5087	UTSP TYPE ELECTROLYTIC CAPACITOR	CE04W50V-10M(UTSP)	1	397581007AT	N	
C5088	UTSP TYPE ELECTROLYTIC CAPACITOR	CE04W50V-10M(UTSP)	1	397581007AT	N	
C5485	UPZ TYPE PLASTIC FILM CAPACITOR	2AUPZTF101JE	1	376331014T		NSP
C5486	UPZ TYPE PLASTIC FILM CAPACITOR	2AUPZTF101JE	1	376331014T		NSP
C5487	UPZ TYPE PLASTIC FILM CAPACITOR	2AUPZTF101JE	1	376331014T		NSP
C5488	UPZ TYPE PLASTIC FILM CAPACITOR	2AUPZTF101JE	1	376331014T		NSP
C5505	VR TYPE ELECTROLYTIC CAPACITOR	CE04W100V-22M(VR)	1	394692207T		
C5506	VR TYPE ELECTROLYTIC CAPACITOR	CE04W100V-22M(VR)	1	394692207T		
C5507	VR TYPE ELECTROLYTIC CAPACITOR	CE04W100V-22M(VR)	1	394692207T		
C5508	VR TYPE ELECTROLYTIC CAPACITOR	CE04W100V-22M(VR)	1	394692207T		
C5525	VR TYPE ELECTROLYTIC CAPACITOR	CE04W100V-22M(VR)	1	394692207T		
C5526	VR TYPE ELECTROLYTIC CAPACITOR	CE04W100V-22M(VR)	1	394692207T		
C5527	VR TYPE ELECTROLYTIC CAPACITOR	CE04W100V-22M(VR)	1	394692207T		
C5528	VR TYPE ELECTROLYTIC CAPACITOR	CE04W100V-22M(VR)	1	394692207T		
C5625	CHIP TYPE CERAMIC CAPACITOR	CK725B1H-103K1	1	332101035R1		NSP
C5626	CHIP TYPE CERAMIC CAPACITOR	CK725B1H-103K1	1	332101035R1		NSP
C5627	CHIP TYPE CERAMIC CAPACITOR	CK725B1H-103K1	1	332101035R1		NSP
C5628	CHIP TYPE CERAMIC CAPACITOR	CK725B1H-103K1	1	332101035R1		NSP
C5645	UTSP TYPE ELECTROLYTIC CAPACITOR	CE04W50V 47M(UTSP)	1	397584707AT	N	
C5646	UTSP TYPE ELECTROLYTIC CAPACITOR	CE04W50V 47M(UTSP)	1	397584707AT	N	
C5647	UTSP TYPE ELECTROLYTIC CAPACITOR	CE04W50V 47M(UTSP)	1	397584707AT	N	
C5648	UTSP TYPE ELECTROLYTIC CAPACITOR	CE04W50V 47M(UTSP)	1	397584707AT	N	
C6305	UTSP TYPE ELECTROLYTIC CAPACITOR	CE04W50V 47M(UTSP)	1	397584707AT	N	
C6306	UTSP TYPE ELECTROLYTIC CAPACITOR	CE04W50V 47M(UTSP)	1	397584707AT	N	
C6307	UTSP TYPE ELECTROLYTIC CAPACITOR	CE04W50V 47M(UTSP)	1	397584707AT	N	
C6308	UTSP TYPE ELECTROLYTIC CAPACITOR	CE04W50V 47M(UTSP)	1	397584707AT	N	
C6405	CERAMIC CAPACITOR	CC45SL50V-040C	1	345020401T		NSP
C6406	CERAMIC CAPACITOR	CC45SL50V-040C	1	345020401T		NSP
C6407	CERAMIC CAPACITOR	CC45SL50V-040C	1	345020401T		NSP
C6408	CERAMIC CAPACITOR	CC45SL50V-040C	1	345020401T		NSP
C6425	UTSP TYPE ELECTROLYTIC CAPACITOR	CE04W25V-220M(UTSP)	1	397552217T		
C6426	UTSP TYPE ELECTROLYTIC CAPACITOR	CE04W25V-220M(UTSP)	1	397552217T		

C6427	UTSP TYPE ELECTROLYTIC CAPACITOR	CE04W25V-220M(UTSP)	1	397552217T	
C6428	UTSP TYPE ELECTROLYTIC CAPACITOR	CE04W25V-220M(UTSP)	1	397552217T	
C6461	UMXR TYPE PLASTIC FILM CAPACITOR	1JUMXRTF473JE	1	376594734T	N NSP
C6462	UMXR TYPE PLASTIC FILM CAPACITOR	1JUMXRTF473JE	1	376594734T	N NSP
C6463	UMXR TYPE PLASTIC FILM CAPACITOR	1JUMXRTF473JE	1	376594734T	N NSP
C6465	UMXR TYPE PLASTIC FILM CAPACITOR	1JUMXRTF473JE	1	376594734T	N NSP
C6466	UMXR TYPE PLASTIC FILM CAPACITOR	1JUMXRTF473JE	1	376594734T	N NSP
C6467	UMXR TYPE PLASTIC FILM CAPACITOR	1JUMXRTF473JE	1	376594734T	N NSP
C6468	UMXR TYPE PLASTIC FILM CAPACITOR	1JUMXRTF473JE	1	376594734T	N NSP
C6601	FILM C	C281H224J20A21A	1	376822244T	N NSP
C6602	FILM C	C281H224J20A21A	1	376822244T	N NSP
C6603	FILM C	C281H224J20A21A	1	376822244T	N NSP
C6605	FILM C	C281H224J20A21A	1	376822244T	N NSP
C6606	FILM C	C281H224J20A21A	1	376822244T	N NSP
C6607	FILM C	C281H224J20A21A	1	376822244T	N NSP
C6608	FILM C	C281H224J20A21A	1	376822244T	N NSP
C6700	UMXR TYPE PLASTIC FILM CAPACITOR	1JUMXRTF103JE	1	376591034T	N NSP
C6703	CHIP TYPE CERAMIC CAPACITOR	CC725CH1H-101J1	1	342101014R1	NSP
C6704	CHIP TYPE CERAMIC CAPACITOR	CK725F1A-105Z1	1	332181050R1	NSP
C6705	CHIP TYPE CERAMIC CAPACITOR	CK725B1H-222K1	1	332102225R1	NSP
C6741	JAMICON TYPE ELECTROLYTIC CAPACITC	CE04W25V-220M	1	398552217T	
C6741or	UTSP TYPE ELECTROLYTIC CAPACITOR	CE04W25V-220M(UTSP)	(1)	397552217T	
C6742	CHIP TYPE CERAMIC CAPACITOR	CK725F1E-104Z1	1	332161040R1	NSP
C6744	JAMICON TYPE ELECTROLYTIC CAPACITC	CE04W50V-1M	1	398580107T	
C6744or	UTSP TYPE ELECTROLYTIC CAPACITOR	CE04W50V-1M(UTSP)	(1)	397580107AT	
C6780	JAMICON TYPE ELECTROLYTIC CAPACITC	CE04W50V-10M	1	398581007T	
C6780or	UTSP TYPE ELECTROLYTIC CAPACITOR	CE04W50V-10M(UTSP)	(1)	397581007AT	
C6800	CHIP TYPE CERAMIC CAPACITOR	CK725F1E-104Z1	1	332161040R1	NSP
C6801	CHIP TYPE CERAMIC CAPACITOR	CK725F1E-104Z1	1	332161040R1	NSP
C6901	ELECTROLYTIC CAPACITOR	CE69W63V-6800M	1	3504506	N
C6901or	ELECTROLYTIC CAPACITOR	CE69W63V-6800M	(1)	3504518	
C6902	ELECTROLYTIC CAPACITOR	CE69W63V-6800M	1	3504506	N
C6902or	ELECTROLYTIC CAPACITOR	CE69W63V-6800M	(1)	3504518	
C6903	FILM C	C282A334J20A21A	1	376833344T	N NSP
C6904	FILM C	C282A334J20A21A	1	376833344T	N NSP
C6911	CHIP TYPE CERAMIC CAPACITOR	CK725B1H-104K1	1	332101045R1	N NSP
[Resistors]					
R4001	CHIP TYPE CARBON RESISTOR	RN72K1J-331JE	1	435033314R1	NSP
R4002	CHIP TYPE CARBON RESISTOR	RN72K1J-331JE	1	435033314R1	NSP
R4003	CHIP TYPE CARBON RESISTOR	RN72K1J-104JE	1	435031044R1	NSP
R4004	CHIP TYPE CARBON RESISTOR	RN72K1J-104JE	1	435031044R1	NSP
R4005	CHIP TYPE CARBON RESISTOR	RN72K1J-331JE	1	435033314R1	NSP
R4006	CHIP TYPE CARBON RESISTOR	RN72K1J-331JE	1	435033314R1	NSP
R4007	CHIP TYPE CARBON RESISTOR	RN72K1J-104JE	1	435031044R1	NSP
R4008	CHIP TYPE CARBON RESISTOR	RN72K1J-104JE	1	435031044R1	NSP
R4009	CHIP TYPE CARBON RESISTOR	RN72K1J-331JE	1	435033314R1	NSP
R4010	CHIP TYPE CARBON RESISTOR	RN72K1J-331JE	1	435033314R1	NSP
R4011	CHIP TYPE CARBON RESISTOR	RN72K1J-104JE	1	435031044R1	NSP
R4012	CHIP TYPE CARBON RESISTOR	RN72K1J-104JE	1	435031044R1	NSP
R4013	CHIP TYPE CARBON RESISTOR	RN72K1J-331JE	1	435033314R1	NSP
R4014	CHIP TYPE CARBON RESISTOR	RN72K1J-331JE	1	435033314R1	NSP
R4015	CHIP TYPE CARBON RESISTOR	RN72K1J-104JE	1	435031044R1	NSP
R4016	CHIP TYPE CARBON RESISTOR	RN72K1J-104JE	1	435031044R1	NSP
R4017	CHIP TYPE CARBON RESISTOR	RN72K1J-331JE	1	435033314R1	NSP
R4018	CHIP TYPE CARBON RESISTOR	RN72K1J-331JE	1	435033314R1	NSP

R4115	CHIP TYPE CARBON RESISTOR	RN72K1J-222JE	1	435032224R1	NSP
R4116	CHIP TYPE CARBON RESISTOR	RN72K1J-222JE	1	435032224R1	NSP
R4117	CHIP TYPE CARBON RESISTOR	RN72K1J-222JE	1	435032224R1	NSP
R4118	CHIP TYPE CARBON RESISTOR	RN72K1J-222JE	1	435032224R1	NSP
R4121	CHIP TYPE CARBON RESISTOR	RN72K1J-000JE	1	435030004R1	NSP
R4122	CHIP TYPE CARBON RESISTOR	RN72K1J-000JE	1	435030004R1	NSP
R4123	CHIP TYPE CARBON RESISTOR	RN72K1J-000JE	1	435030004R1	NSP
R4124	CHIP TYPE CARBON RESISTOR	RN72K1J-101JE	1	435031014R1	NSP
R4125	CHIP TYPE CARBON RESISTOR	RN72K1J-000JE	1	435030004R1	NSP
R4126	CHIP TYPE CARBON RESISTOR	RN72K1J-000JE	1	435030004R1	NSP
R4127	CHIP TYPE CARBON RESISTOR	RN72K1J-000JE	1	435030004R1	NSP
R4128	CHIP TYPE CARBON RESISTOR	RN72K1J-000JE	1	435030004R1	NSP
R4131	CHIP TYPE CARBON RESISTOR	RN72K1J-000JE	1	435030004R1	NSP
R4132	CHIP TYPE CARBON RESISTOR	RN72K1J-000JE	1	435030004R1	NSP
R4133	CHIP TYPE CARBON RESISTOR	RN72K1J-000JE	1	435030004R1	NSP
R4135	CHIP TYPE CARBON RESISTOR	RN72K1J-000JE	1	435030004R1	NSP
R4136	CHIP TYPE CARBON RESISTOR	RN72K1J-000JE	1	435030004R1	NSP
R4137	CHIP TYPE CARBON RESISTOR	RN72K1J-000JE	1	435030004R1	NSP
R4138	CHIP TYPE CARBON RESISTOR	RN72K1J-000JE	1	435030004R1	NSP
R4141	CHIP TYPE CARBON RESISTOR	RN72K1J-000JE	1	435030004R1	NSP
R4142	CHIP TYPE CARBON RESISTOR	RN72K1J-000JE	1	435030004R1	NSP
R4143	CHIP TYPE CARBON RESISTOR	RN72K1J-000JE	1	435030004R1	NSP
R4146	CHIP TYPE CARBON RESISTOR	RN72K1J-000JE	1	435030004R1	NSP
R4147	CHIP TYPE CARBON RESISTOR	RN72K1J-000JE	1	435030004R1	NSP
R4154	CHIP TYPE CARBON RESISTOR	RN72K1J-224JE	1	435032244R1	NSP
R4164	CHIP TYPE CARBON RESISTOR	RN72K1J-101JE	1	435031014R1	NSP
R4174	CHIP TYPE CARBON RESISTOR	RN72K1J-101JE	1	435031014R1	NSP
R4175	CHIP TYPE CARBON RESISTOR	RN72K1J-220JE	1	435032204R1	NSP
R4176	CHIP TYPE CARBON RESISTOR	RN72K1J-220JE	1	435032204R1	NSP
R4181	CHIP TYPE CARBON RESISTOR	RN72K1J-102JE	1	435031024R1	NSP
R4182	CHIP TYPE CARBON RESISTOR	RN72K1J-224JE	1	435032244R1	NSP
R4183	CHIP TYPE CARBON RESISTOR	RN72K1J-224JE	1	435032244R1	NSP
R4185	CHIP TYPE CARBON RESISTOR	RN72K1J-224JE	1	435032244R1	NSP
R4190	CHIP TYPE CARBON RESISTOR	RN72K1J-221JE	1	435032214R1	NSP
R4191	CHIP TYPE CARBON RESISTOR	RN72K1J-473JE	1	435034734R1	NSP
R4192	CHIP TYPE CARBON RESISTOR	RN72K1J-153JE	1	435031534R1	NSP
R4193	CHIP TYPE CARBON RESISTOR	RN72K1J-122JE	1	435031224R1	NSP
R4194	CHIP TYPE CARBON RESISTOR	RN72K1J-103JE	1	435031034R1	NSP
R4251	METAL RESISTOR	RNU1WCJ-2.2	1	453630224T	NSP
R4252	METAL RESISTOR	RNU1WCJ-2.2	1	453630224T	NSP
R4253	METAL RESISTOR	RNU1WCJ-2.2	1	453630224T	NSP
R4254	METAL RESISTOR	RNU1WCJ-2.2	1	453630224T	NSP
R4255	METAL RESISTOR	RNU1WCJ-2.2	1	453630224T	NSP
R4256	METAL OXIDE FILM RESISTOR	RS1WBJ-10	1	443621004T	NSP
R4259	METAL OXIDE FILM RESISTOR	RS1/2WBJ-47	1	443524704T	NSP
R4260	METAL OXIDE FILM RESISTOR	RS1/2WBJ-47	1	443524704T	NSP
R4261	METAL OXIDE FILM RESISTOR	RS1WBJ-68	1	443626804T	NSP
R4262	METAL OXIDE FILM RESISTOR	RS1WBJ-68	1	443626804T	NSP
R4263	METAL OXIDE FILM RESISTOR	RS1WBJ-68	1	443626804T	NSP
R4264	METAL OXIDE FILM RESISTOR	RS1WBJ-68	1	443626804T	NSP
R4269	CHIP TYPE CARBON RESISTOR	RN72K1J-100JE	1	435031004R1	NSP
R4270	CHIP TYPE CARBON RESISTOR	RN72K1J-100JE	1	435031004R1	NSP
R4307	CHIP TYPE CARBON RESISTOR	RN72K1J-222JE	1	435032224R1	NSP
R4308	CHIP TYPE CARBON RESISTOR	RN72K1J-222JE	1	435032224R1	NSP
R4309	CHIP TYPE CARBON RESISTOR	RN72K1J-224JE	1	435032244R1	NSP

R4310	CHIP TYPE CARBON RESISTOR	RN72K1J-224JE	1	435032244R1	NSP
R4311	CHIP TYPE CARBON RESISTOR	RN72K1J-101JE	1	435031014R1	NSP
R4312	CHIP TYPE CARBON RESISTOR	RN72K1J-101JE	1	435031014R1	NSP
R4401	CHIP TYPE CARBON RESISTOR	RN72K1J-000JE	1	435030004R1	NSP
R4402	CHIP TYPE CARBON RESISTOR	RN72K1J-000JE	1	435030004R1	NSP
R4403	CHIP TYPE CARBON RESISTOR	RN72K1J-000JE	1	435030004R1	NSP
R4404	CHIP TYPE CARBON RESISTOR	RN72K1J-000JE	1	435030004R1	NSP
R4407	CHIP TYPE CARBON RESISTOR	RN72K1J-000JE	1	435030004R1	NSP
R4408	CHIP TYPE CARBON RESISTOR	RN72K1J-000JE	1	435030004R1	NSP
R4411	CHIP TYPE CARBON RESISTOR	RN72K1J-000JE	1	435030004R1	NSP
R4412	CHIP TYPE CARBON RESISTOR	RN72K1J-000JE	1	435030004R1	NSP
R4421	CHIP TYPE CARBON RESISTOR	RN72K1J-000JE	1	435030004R1	NSP
R4424	CHIP TYPE CARBON RESISTOR	RN72K1J-000JE	1	435030004R1	NSP
R4531	CHIP TYPE CARBON RESISTOR	RN72K1J-224JE	1	435032244R1	NSP
R4532	CHIP TYPE CARBON RESISTOR	RN72K1J-224JE	1	435032244R1	NSP
R4533	CHIP TYPE CARBON RESISTOR	RN72K1J-561JE	1	435035614R1	NSP
R4534	CHIP TYPE CARBON RESISTOR	RN72K1J-561JE	1	435035614R1	NSP
R4535	CHIP TYPE CARBON RESISTOR	RN72K1J-274JE	1	435032744R1	NSP
R4536	CHIP TYPE CARBON RESISTOR	RN72K1J-274JE	1	435032744R1	NSP
R4537	CHIP TYPE CARBON RESISTOR	RN72K1J-223JE	1	435032234R1	NSP
R4538	CHIP TYPE CARBON RESISTOR	RN72K1J-223JE	1	435032234R1	NSP
R4539	CHIP TYPE CARBON RESISTOR	RN72K1J-000JE	1	435030004R1	NSP
R4540	CHIP TYPE CARBON RESISTOR	RN72K1J-000JE	1	435030004R1	NSP
R4541	CHIP TYPE CARBON RESISTOR	RN72K1J-331JE	1	435033314R1	NSP
R4542	CHIP TYPE CARBON RESISTOR	RN72K1J-331JE	1	435033314R1	NSP
R4543	CHIP TYPE CARBON RESISTOR	RN72K1J-224JE	1	435032244R1	NSP
R4544	CHIP TYPE CARBON RESISTOR	RN72K1J-224JE	1	435032244R1	NSP
R4546	CHIP TYPE CARBON RESISTOR	RN72K1J-220JE	1	435032204R1	NSP
R4547	CHIP TYPE CARBON RESISTOR	RN72K1J-220JE	1	435032204R1	NSP
R4548	CHIP TYPE CARBON RESISTOR	RN72K1J-000JE	1	435030004R1	NSP
R4549	CHIP TYPE CARBON RESISTOR	RN72K1J-000JE	1	435030004R1	NSP
R4550	CHIP TYPE CARBON RESISTOR	RN72K1J-000JE	1	435030004R1	NSP
R4551	CHIP TYPE CARBON RESISTOR	RN72K1J-000JE	1	435030004R1	NSP
R5005	CHIP TYPE CARBON RESISTOR	RN72K1J-152JE	1	435031524R1	NSP
R5006	CHIP TYPE CARBON RESISTOR	RN72K1J-152JE	1	435031524R1	NSP
R5007	CHIP TYPE CARBON RESISTOR	RN72K1J-152JE	1	435031524R1	NSP
R5008	CHIP TYPE CARBON RESISTOR	RN72K1J-152JE	1	435031524R1	NSP
R5025	CHIP TYPE CARBON RESISTOR	RN72K1J-563JE	1	435035634R1	NSP
R5026	CHIP TYPE CARBON RESISTOR	RN72K1J-563JE	1	435035634R1	NSP
R5027	CHIP TYPE CARBON RESISTOR	RN72K1J-563JE	1	435035634R1	NSP
R5028	CHIP TYPE CARBON RESISTOR	RN72K1J-563JE	1	435035634R1	NSP
R5045	CHIP TYPE CARBON RESISTOR	RN72K1J-331JE	1	435033314R1	NSP
R5046	CHIP TYPE CARBON RESISTOR	RN72K1J-331JE	1	435033314R1	NSP
R5047	CHIP TYPE CARBON RESISTOR	RN72K1J-331JE	1	435033314R1	NSP
R5048	CHIP TYPE CARBON RESISTOR	RN72K1J-331JE	1	435033314R1	NSP
R5065	METAL OXIDE FILM RESISTOR	RS1/2WBJ-100K	1	443521044T	N NSP
R5066	METAL OXIDE FILM RESISTOR	RS1/2WBJ-100K	1	443521044T	N NSP
R5067	METAL OXIDE FILM RESISTOR	RS1/2WBJ-100K	1	443521044T	N NSP
R5068	METAL OXIDE FILM RESISTOR	RS1/2WBJ-100K	1	443521044T	N NSP
R5085	CHIP TYPE CARBON RESISTOR	RN72K1J-104JE	1	435031044R1	NSP
R5086	CHIP TYPE CARBON RESISTOR	RN72K1J-104JE	1	435031044R1	NSP
R5087	CHIP TYPE CARBON RESISTOR	RN72K1J-104JE	1	435031044R1	NSP
R5088	CHIP TYPE CARBON RESISTOR	RN72K1J-104JE	1	435031044R1	NSP
R5105	CHIP TYPE CARBON RESISTOR	RN72K1J-152JE	1	435031524R1	NSP
R5106	CHIP TYPE CARBON RESISTOR	RN72K1J-152JE	1	435031524R1	NSP

R5887	CHIP TYPE CARBON RESISTOR	RN72K1J-000JE	1	435030004R1	NSP
R5888	CHIP TYPE CARBON RESISTOR	RN72K1J-000JE	1	435030004R1	NSP
R6005	METAL OXIDE FILM RESISTOR	RS2WBJ-0.22	1	442722294T	
R6006	METAL OXIDE FILM RESISTOR	RS2WBJ-0.22	1	442722294T	
R6007	METAL OXIDE FILM RESISTOR	RS2WBJ-0.22	1	442722294T	
R6008	METAL OXIDE FILM RESISTOR	RS2WBJ-0.22	1	442722294T	
R6025	METAL OXIDE FILM RESISTOR	RS2WBJ-0.22	1	442722294T	
R6026	METAL OXIDE FILM RESISTOR	RS2WBJ-0.22	1	442722294T	
R6027	METAL OXIDE FILM RESISTOR	RS2WBJ-0.22	1	442722294T	
R6028	METAL OXIDE FILM RESISTOR	RS2WBJ-0.22	1	442722294T	
R6081	METAL PLATE RESISTOR	MPR5W+5W 0R22	1	4000233	
R6082	METAL PLATE RESISTOR	MPR5W+5W 0R22	1	4000233	
R6083	METAL PLATE RESISTOR	MPR5W+5W 0R22	1	4000233	
R6141	NON-FLAMMABLE CARBON FILM RESISTOR	R25J-0.22	1	415472294T	
R6142	NON-FLAMMABLE CARBON FILM RESISTOR	R25J-0.22	1	415472294T	
R6143	NON-FLAMMABLE CARBON FILM RESISTOR	R25J-0.22	1	415472294T	
R6145	NON-FLAMMABLE CARBON FILM RESISTOR	R25J-0.22	1	415472294T	
R6146	NON-FLAMMABLE CARBON FILM RESISTOR	R25J-0.22	1	415472294T	
R6147	NON-FLAMMABLE CARBON FILM RESISTOR	R25J-0.22	1	415472294T	
R6148	NON-FLAMMABLE CARBON FILM RESISTOR	R25J-0.22	1	415472294T	
R6161	NON-FLAMMABLE CARBON FILM RESISTOR	R25J-0.22	1	415472294T	
R6162	NON-FLAMMABLE CARBON FILM RESISTOR	R25J-0.22	1	415472294T	
R6163	NON-FLAMMABLE CARBON FILM RESISTOR	R25J-0.22	1	415472294T	
R6165	NON-FLAMMABLE CARBON FILM RESISTOR	R25J-0.22	1	415472294T	
R6166	NON-FLAMMABLE CARBON FILM RESISTOR	R25J-0.22	1	415472294T	
R6167	NON-FLAMMABLE CARBON FILM RESISTOR	R25J-0.22	1	415472294T	
R6168	NON-FLAMMABLE CARBON FILM RESISTOR	R25J-0.22	1	415472294T	
R6305	NON-FLAMMABLE CARBON FILM RESISTOR	R25J-120	1	415471214T	
R6306	NON-FLAMMABLE CARBON FILM RESISTOR	R25J-120	1	415471214T	
R6307	NON-FLAMMABLE CARBON FILM RESISTOR	R25J-120	1	415471214T	
R6308	NON-FLAMMABLE CARBON FILM RESISTOR	R25J-120	1	415471214T	
R6405	NON-FLAMMABLE CARBON FILM RESISTOR	R25J-56K	1	415475634T	N
R6406	NON-FLAMMABLE CARBON FILM RESISTOR	R25J-56K	1	415475634T	N
R6407	NON-FLAMMABLE CARBON FILM RESISTOR	R25J-56K	1	415475634T	N
R6408	NON-FLAMMABLE CARBON FILM RESISTOR	R25J-56K	1	415475634T	N
R6425	CHIP TYPE CARBON RESISTOR	RN72K1J-182JE	1	435031824R1	NSP
R6426	CHIP TYPE CARBON RESISTOR	RN72K1J-182JE	1	435031824R1	NSP
R6427	CHIP TYPE CARBON RESISTOR	RN72K1J-182JE	1	435031824R1	NSP
R6428	CHIP TYPE CARBON RESISTOR	RN72K1J-182JE	1	435031824R1	NSP
R6441	CHIP TYPE CARBON RESISTOR	RN72K2E-100JE	1	435221004R1	NSP
R6442	CHIP TYPE CARBON RESISTOR	RN72K2E-100JE	1	435221004R1	NSP
R6443	CHIP TYPE CARBON RESISTOR	RN72K2E-100JE	1	435221004R1	NSP
R6445	CHIP TYPE CARBON RESISTOR	RN72K2E-100JE	1	435221004R1	NSP
R6446	CHIP TYPE CARBON RESISTOR	RN72K2E-100JE	1	435221004R1	NSP
R6447	CHIP TYPE CARBON RESISTOR	RN72K2E-100JE	1	435221004R1	NSP
R6448	CHIP TYPE CARBON RESISTOR	RN72K2E-100JE	1	435221004R1	NSP
R6461	METAL RESISTOR	RNU1WCJ-8.2	1	453630824T	NSP
R6462	METAL RESISTOR	RNU1WCJ-8.2	1	453630824T	NSP
R6463	METAL RESISTOR	RNU1WCJ-8.2	1	453630824T	NSP
R6465	METAL RESISTOR	RNU1WCJ-8.2	1	453630824T	NSP
R6466	METAL RESISTOR	RNU1WCJ-8.2	1	453630824T	NSP
R6467	METAL RESISTOR	RNU1WCJ-8.2	1	453630824T	NSP
R6468	METAL RESISTOR	RNU1WCJ-8.2	1	453630824T	NSP
R6601	CHIP TYPE CARBON RESISTOR	RN72K1J-223JE	1	435032234R1	NSP
R6602	CHIP TYPE CARBON RESISTOR	RN72K1J-223JE	1	435032234R1	NSP

R6763	CHIP TYPE CARBON RESISTOR	RN72K1J-473JE	1	435034734R1	NSP
R6765	CHIP TYPE CARBON RESISTOR	RN72K1J-473JE	1	435034734R1	NSP
R6766	CHIP TYPE CARBON RESISTOR	RN72K1J-473JE	1	435034734R1	NSP
R6767	CHIP TYPE CARBON RESISTOR	RN72K1J-473JE	1	435034734R1	NSP
R6768	CHIP TYPE CARBON RESISTOR	RN72K1J-473JE	1	435034734R1	NSP
R6780	CHIP TYPE CARBON RESISTOR	RN72K1J-562JE	1	435035624R1	NSP
R6781	CHIP TYPE CARBON RESISTOR	RN72K1J-562JE	1	435035624R1	NSP
R6793	CHIP TYPE CARBON RESISTOR	RN72K1J-000JE	1	435030004R1	NSP
R6795	CHIP TYPE CARBON RESISTOR	RN72K1J-000JE	1	435030004R1	NSP
R6796	CHIP TYPE CARBON RESISTOR	RN72K1J-000JE	1	435030004R1	NSP
R6797	CHIP TYPE CARBON RESISTOR	RN72K1J-000JE	1	435030004R1	NSP
R6802	CHIP TYPE CARBON RESISTOR	RN72K1J-153FE	1	435031532R1	NSP
R6803	CHIP TYPE CARBON RESISTOR	RN72K1J-473FE	1	435034732R1	N NSP
R6804	CHIP TYPE CARBON RESISTOR	RN72K1J-184JE	1	435031844R1	NSP
R6805	CHIP TYPE CARBON RESISTOR	RN72K1J-223FE	1	435032232R1	NSP
R6806	THERMISTOR	PRF18BF471QB5RB	1	4000286R2	N NSP
R6808	CHIP TYPE CARBON RESISTOR	RN72K1J-224JE	1	435032244R1	NSP
R6901	METAL RESISTOR	RNU1/2WCJ-0.1	1	453531094T	NSP
R6913	METAL OXIDE FILM RESISTOR	RS1/2WBJ-33	1	443523304T	NSP
[Switches, Terminals, Wires]					
F6901C	FUSE HOLDER	NSCT-1P2031	1	25052133T	! NSP
F6901D	FUSE HOLDER	NSCT-1P2031	1	25052133T	! NSP
F6902C	FUSE HOLDER	NSCT-1P2031	1	25052133T	! NSP
F6902D	FUSE HOLDER	NSCT-1P2031	1	25052133T	! NSP
P0001B	PRINTED WIRING BOARD	BCETC-1980	{1}	25141980	N NSP
P0001C	PRINTED WIRING BOARD	BCETC-1981	{1}	25141981	N NSP
P010	PRINTED WIRING BOARD	BCAF-1979	1	25141979	N NSP
P0100	PRINTED WIRING BOARD	BCAF-1979	{1}	25141979A	N NSP
P1501B	SOCKET	IMSA-9142S-22A	1	25053233	NSP
P1502B	SOCKET	IMSA-9142S-22A	1	25053233	NSP
P1511B	RETAINER	(TRM)	1	25060507	NSP
P4001	PIN JACK	NPJ-4PDWWRR624	1	25045845	
P4002	PIN JACK	NPJ-4PDWWRR624	1	25045845	
P4003	PIN JACK	NPJ-4PDWWRR624	1	25045845	
P4004	PIN JACK	NPJ-2PDWR558	1	25045776	
P4005	PIN JACK	NPJ-4PDRWB785	1	25046056	N
P4011	TRM-423(SCREW)	NEJITANSI ST3	1	25060495	NSP
P5506B	RETAINER	(TRM)	1	25060507	NSP
P5509A	RETAINER	(TRM)	1	25060507	NSP
P6001B	PLUG	NPLG-9P0964	1	25056014	NSP
P6002B	PLUG	NPLG-9P0964	1	25056014	NSP
P6003B	PLUG	NPLG-9P0964	1	25056014	NSP
P6021	PLUG	NPLG-2P29	1	25055038	NSP
P6022	PLUG	NPLG-2P29	1	25055038	NSP
P6023	PLUG	NPLG-2P29	1	25055038	NSP
P6025	PLUG	NPLG-2P29	1	25055038	NSP
P6026	PLUG	NPLG-2P29	1	25055038	NSP
P6027	PLUG	NPLG-2P29	1	25055038	NSP
P6028	PLUG	NPLG-2P29	1	25055038	NSP
P6400	WIRE HARNESS ASSEMBLY	NSAS-7P2206	1	2009991395UL	N NSP
P6400A	WIRE HOL	CHD-2.5-7	1	25053542	N NSP
P6400Aor	WIRE HOL	NSCT-7P898	(1)	25051111	NSP
P6401	WIRE HARNESS ASSEMBLY	NSAS-9P2223	1	2009991412UL	N NSP
P6401A	WIRE HOL	CHD-2.5-9	1	25053543	N NSP
P6401Aor	WIRE HOL	NSCT-9P900	(1)	25051113	NSP

P6800	WIRE HARNESS ASSEMBLY	NSAS-5P2110	1	2009991299UL	N	NSP
P6800A	WIRE HOL	CHD-1.5-5	1	25053536	N	NSP
P6800Aor	WIRE HOL	NSCT-3P874	(1)	25051087		NSP
P6901	PLUG	NPLG-5P152	1	25055168	N	NSP
P6902A	CRIMP CORD ASSEMBLY	CLIMP AS	1	2069925080UL	N	NSP
P6903A	CRIMP CORD ASSEMBLY	CRIMP AS	1	2069925242UL	N	NSP
P6904A	CRIMP CORD ASSEMBLY	CRIMP AS	1	2069925166UL	N	NSP
RL6911	RELAY	NRL-1P10A-DC12-196	1	25065707		
RL6912	RELAY	NRL-1P10A-DC12-196	1	25065707		
[Frontend, Units]						
BAAF-1979	Audio frequency circuit pc board AS	BAAF-1979-1A	1	1B5141979-1A-C		Child
BAETC-1980	Et cetra pc board AS	BAETC-1980-1A	1	1B5141980-1A-C		Child
BAETC-1981	Et cetra pc board AS	BAETC-1981-1A	1	1B5141981-1A-C		Child

BADIS-1983-1A**<Note>**

Parts marked by "NSP" are generally unavailable because they are not in our Master Spare Parts List.

<Notes>

█ : NSP

NOTE : THE COMPONENTS IDENTIFIED BY THE MARK ! ARE CRITICAL FOR RISK OF FIRE AND ELECTRIC SHOCK. REPLACE ONLY WITH PART

REF. NO.	PART NAME	DESCRIPTION	Q'TY	PART NO. (SN)	REMARKS
[Semi-conductors]					
D5081	ZENER DIODE	DZ2J056M0L	1	224760560R2	NSP
D5082	ZENER DIODE	DZ2J056M0L	1	224760560R2	NSP
D5083	ZENER DIODE	DZ2J056M0L	1	224760560R2	NSP
D7500	ZENER DIODE	DZ2J039M0L	1	224760390R2	NSP
D7750	LED	HLMP-Y701	1	225528	N
D7751	LED	SCB3318E-D2	1	225487	
D7751A	HOLDER	(LED)LH-5-5	1	27191312	NSP
D7851	ZENER DIODE	DZ2J068M0L	1	224760680R2	NSP
D7852	ZENER DIODE	DZ2J068M0L	1	224760680R2	NSP
D7900	DIODE	RL1N4003	1	22380260T	NSP
D7901	DIODE	RL1N4003	1	22380260T	NSP
D7902	DIODE	RL1N4003	1	22380260T	NSP
D7903	DIODE	RL1N4003	1	22380260T	NSP
D7904	ZENER DIODE	DZ2J200M0L	1	224762000R2	N NSP
D7905	ZENER DIODE	DZ2J180M0L	1	224761800R2	N NSP
D7906	ZENER DIODE	DZ2J075M0L	1	224760750R2	NSP
D9001	DIODE	S1WB(A)60B-7062	1	22380377R2	NSP
D9002	SPECIFIED DIODE	P6SMB200A-M3/52T	1	225505R2	NSP
D9003	DIODE	GU1M-60A-2	1	22380405R2	N NSP
D9003or	DIODE	US1K-E3/61T	(1)	22380376R2	NSP
D9004	DIODE	RF301BM2STL	1	22380388R2	N NSP
D9006	DIODE	M1FL20U	1	223276R2	NSP
D9008	DIODE	RBR3MM30ATR	1	22380401R2	N NSP
D9011	CHIP TYPE DIODE	DA2J10100	1	223303R2	NSP
D9012	ZENER DIODE	DZ2J360M0L	1	224763600R2	NSP
D9013	SPECIFIED DIODE	P6SMB20A-M3/52	1	225515R2	N NSP
D9018	ZENER DIODE	DZ2J200M0L	1	224762000R2	N NSP
Q1	HYBRID IC	RZ5B801-0001E2	1	22242835R2	N NSP
Q1501	HYBRID IC	NJM4580CG	1	22242922R2	N NSP
Q1503	HYBRID IC	NJM4580CG	1	22242922R2	N NSP
Q1505	HYBRID IC	NJM4580CG	1	22242922R2	N NSP
Q1507	HYBRID IC	NJM4580CG	1	22242922R2	N NSP
Q1521	HYBRID IC	NJM4580CG	1	22242922R2	N NSP
Q1522	HYBRID IC	NJM4580CG	1	22242922R2	N NSP
Q1541	HYBRID IC	NJM4580CG	1	22242922R2	N NSP
Q1921	HYBRID IC	TC7WU04FU(TE12L_F)	1	22240935R2	NSP
Q1922	PHOTO COUPLER	JSR1165-001recieving	1	24120143	
Q1923	PHOTO COUPLER	JSR1165-001recieving	1	24120143	
Q5101	TRANSISTOR	2SC2713-BL	1	2213136R2	
Q5102	TRANSISTOR	2SC2713-BL	1	2213136R2	
Q5103	TRANSISTOR	2SC2713-BL	1	2213136R2	
Q5121	TRANSISTOR	2SC2713-BL	1	2213136R2	
Q5122	TRANSISTOR	2SC2713-BL	1	2213136R2	
Q5123	TRANSISTOR	2SC2713-BL	1	2213136R2	

Q5221	TRANSISTOR	INC5001AP1-T111	1	2218100R2	N
Q5221or	TRANSISTOR	2SC2881-Y	(1)	2217564AR2	
Q5222	TRANSISTOR	INC5001AP1-T111	1	2218100R2	N
Q5222or	TRANSISTOR	2SC2881-Y	(1)	2217564AR2	
Q5223	TRANSISTOR	INC5001AP1-T111	1	2218100R2	N
Q5223or	TRANSISTOR	2SC2881-Y	(1)	2217564AR2	
Q5381	TRANSISTOR	INA6006AP1-T111	1	2217980R2	N
Q5381or	TRANSISTOR	2SA1200-Y(2LONK_ZE)	(1)	2217584R2	
Q5382	TRANSISTOR	INA6006AP1-T111	1	2217980R2	N
Q5382or	TRANSISTOR	2SA1200-Y(2LONK_ZE)	(1)	2217584R2	
Q5383	TRANSISTOR	INA6006AP1-T111	1	2217980R2	N
Q5383or	TRANSISTOR	2SA1200-Y(2LONK_ZE)	(1)	2217584R2	
Q5401	TRANSISTOR	INC6006AP1-T111	1	2217990R2	N
Q5401or	TRANSISTOR	2SC2880-Y(2LONK_ZE)	(1)	2217594R2	
Q5402	TRANSISTOR	INC6006AP1-T111	1	2217990R2	N
Q5402or	TRANSISTOR	2SC2880-Y(2LONK_ZE)	(1)	2217594R2	
Q5403	TRANSISTOR	INC6006AP1-T111	1	2217990R2	N
Q5403or	TRANSISTOR	2SC2880-Y(2LONK_ZE)	(1)	2217594R2	
Q5621	TRANSISTOR	2SC2713-BL	1	2213136R2	
Q5622	TRANSISTOR	2SC2713-BL	1	2213136R2	
Q5623	TRANSISTOR	2SC2713-BL	1	2213136R2	
Q5641	TRANSISTOR	2SA1163-BL	1	2216756R2	
Q5642	TRANSISTOR	2SA1163-BL	1	2216756R2	
Q5643	TRANSISTOR	2SA1163-BL	1	2216756R2	
Q6101	TRANSISTOR	TTC004B_Q(S)	1	2218022	N
Q6102	TRANSISTOR	TTC004B_Q(S)	1	2218022	N
Q6103	TRANSISTOR	TTC004B_Q(S)	1	2218022	N
Q6121	TRANSISTOR	TTA004B_Q(S)	1	2218012	N
Q6122	TRANSISTOR	TTA004B_Q(S)	1	2218012	N
Q6123	TRANSISTOR	TTA004B_Q(S)	1	2218012	N
Q7500	TRANSISTOR	KTC3875-GR	1	2216175R2	NSP
Q7750	TRANSISTOR	KRC105S	1	2217290R2	NSP
Q7750or	TRANSISTOR	RN1405	(1)	2214500R2	NSP
Q7751	TRANSISTOR	KRC105S	1	2217290R2	NSP
Q7751or	TRANSISTOR	RN1405	(1)	2214500R2	NSP
Q7780	REMOTE SENSOR	IRM-3638M3S28	1	24130026	N
Q7850	HYBRID IC	NJM4580CG	1	22242922R2	N NSP
Q7851	TRANSISTOR	RTAN430C-T112-1	1	2217780R2	NSP
Q7852	TRANSISTOR	KRA102S	1	2216220R2	NSP
Q7852or	TRANSISTOR	RN2402	(1)	2214530R2	NSP
Q7852or	TRANSISTOR	DTA114EKA	(1)	2217050R2	NSP
Q7853	TRANSISTOR	KRC107S	1	2216340R2	NSP
Q7853or	TRANSISTOR	RN1407	(1)	2216260R2	NSP
Q7853or	TRANSISTOR	DTC114YKA	(1)	2216470R2	NSP
Q7900	TRANSISTOR	INC5001AP1-T111	1	2218100R2	N NSP
Q7900or	TRANSISTOR	2SC2881-Y	(1)	2217564AR2	NSP
Q7901	TRANSISTOR	INA5001AP1-T111	1	2218030R2	N NSP
Q7901or	TRANSISTOR	KTA1661-Y	(1)	2217864R2	NSP
Q7902	TRANSISTOR	KRC107S	1	2216340R2	NSP
Q7902or	TRANSISTOR	RN1407	(1)	2216260R2	NSP
Q7903	TRANSISTOR	2SC2712-GR	1	2213145R2	NSP
Q7903or	TRANSISTOR	KTC3875-GR	(1)	2216175R2	NSP
Q7904	TRANSISTOR	2SC2712-GR	1	2213145R2	NSP
Q7904or	TRANSISTOR	KTC3875-GR	(1)	2216175R2	NSP
Q7905	FLUORESCENT TUBE	016MT096GINYK	1	212285A	N

Q7905A	HOLDER	(FL)	1	27191414	N	NSP
Q9001	HYBRID IC	STR-A6051M	1	222154	N	
Q9003	HYBRID IC	EL816MX	1	22242845	N	
Q9004	HYBRID IC	KIA431A-AT/P	1	22242770T		NSP
Q9005	TRANSISTOR	KRC102S	1	2216190R2		NSP
Q9032	TRANSISTOR	KRC102S	1	2216190R2		NSP
Q9032or	TRANSISTOR	RN1402	(1)	2214470R2		NSP
Q9033	TRANSISTOR	KRA102S	1	2216220R2		NSP
Q9033or	TRANSISTOR	RN2402	(1)	2214530R2		NSP
X1	CRYSTAL	HC-49S 9B12.000MHz	1	3010533	N	
[Transformers, Coils]						
L1	CHIP TYPE CARBON RESISTOR	RN72K1J-000JE	1	435030004R1		NSP
L1921	EMI SUPPRESSION FILTER	BK1608HS102-T	1	230955R2		NSP
L1922	CHOKE COIL	LBC2518T470M	1	231364M470R2		NSP
L2	CHIP TYPE CARBON RESISTOR	RN72K1J-000JE	1	435030004R1		NSP
L3	RF COIL	SDCL1608CR33JTDF	1	233557R1	N	NSP
L4	RF COIL	SDCL1608CR10JTDF	1	233556R1	N	NSP
L5	ANTENNA COIL	K7-D	1	232212	N	
L7900	CHOKE COIL	LBC2518T2R2M	1	231364M022R2		NSP
L7901	CHOKE COIL	LBC2518T2R2M	1	231364M022R2		NSP
L9001	CHOKE COIL	EM-UT2014-0033	1	231474	N	
L9002	CHOKE COIL	RCR1010NP-100M	1	231449M100		
L9004	CORE	BLM18PG181SN1D	1	2350005R1		NSP
L9005	CORE	BLM18PG181SN1D	1	2350005R1		NSP
T9001	POWER TRANSFORMER	NPT-1632S	1	2302076	!, N	
T9001or	POWER TRANSFORMER	NPT-1633S	(1)	2302077	!	
[Capacitors]						
C1	CHIP TYPE CERAMIC CAPACITOR	CC725CH1H-101J1	1	342101014R1		NSP
C12	CHIP TYPE CERAMIC CAPACITOR	CC725CH1H-090D1	1	342100902R1		NSP
C13	CHIP TYPE CERAMIC CAPACITOR	CK725B1C-104K1	1	332121045R1		NSP
C1501	UPZ TYPE PLASTIC FILM CAPACITOR	2AUPZTF681JE	1	376336814T		NSP
C1502	UPZ TYPE PLASTIC FILM CAPACITOR	2AUPZTF681JE	1	376336814T		NSP
C1503	UMXR TYPE PLASTIC FILM CAPACITOR	1JUMXRTF392JE	1	376593924T	N	NSP
C1504	UMXR TYPE PLASTIC FILM CAPACITOR	1JUMXRTF392JE	1	376593924T	N	NSP
C1505	UMXR TYPE PLASTIC FILM CAPACITOR	1JUMXRTF392JE	1	376593924T	N	NSP
C1506	UMXR TYPE PLASTIC FILM CAPACITOR	1JUMXRTF392JE	1	376593924T	N	NSP
C1507	UMXR TYPE PLASTIC FILM CAPACITOR	1JUMXRTF392JE	1	376593924T	N	NSP
C1508	UMXR TYPE PLASTIC FILM CAPACITOR	1JUMXRTF392JE	1	376593924T	N	NSP
C1521	UMXR TYPE PLASTIC FILM CAPACITOR	1JUMXRTF122JE	1	376591224T	N	NSP
C1522	UMXR TYPE PLASTIC FILM CAPACITOR	1JUMXRTF122JE	1	376591224T	N	NSP
C1523	UPZ TYPE PLASTIC FILM CAPACITOR	2AUPZTF681JE	1	376336814T		NSP
C1524	UPZ TYPE PLASTIC FILM CAPACITOR	2AUPZTF681JE	1	376336814T		NSP
C1525	UPZ TYPE PLASTIC FILM CAPACITOR	2AUPZTF681JE	1	376336814T		NSP
C1526	UPZ TYPE PLASTIC FILM CAPACITOR	2AUPZTF681JE	1	376336814T		NSP
C1527	UPZ TYPE PLASTIC FILM CAPACITOR	2AUPZTF681JE	1	376336814T		NSP
C1528	UPZ TYPE PLASTIC FILM CAPACITOR	2AUPZTF681JE	1	376336814T		NSP
C1541	UPZ TYPE PLASTIC FILM CAPACITOR	2AUPZTF331JE	1	376333314T		NSP
C1542	UPZ TYPE PLASTIC FILM CAPACITOR	2AUPZTF331JE	1	376333314T		NSP
C1543	UPZ TYPE PLASTIC FILM CAPACITOR	2AUPZTF681JE	1	376336814T		NSP
C1544	UPZ TYPE PLASTIC FILM CAPACITOR	2AUPZTF681JE	1	376336814T		NSP
C1545	UPZ TYPE PLASTIC FILM CAPACITOR	2AUPZTF681JE	1	376336814T		NSP
C1546	UPZ TYPE PLASTIC FILM CAPACITOR	2AUPZTF681JE	1	376336814T		NSP
C1547	UPZ TYPE PLASTIC FILM CAPACITOR	2AUPZTF681JE	1	376336814T		NSP
C1548	UPZ TYPE PLASTIC FILM CAPACITOR	2AUPZTF681JE	1	376336814T		NSP
C1561	UPZ TYPE PLASTIC FILM CAPACITOR	2AUPZTF331JE	1	376333314T		NSP

C1562	UPZ TYPE PLASTIC FILM CAPACITOR	2AUPZTF331JE	1	376333314T	NSP
C1581	UPZ TYPE PLASTIC FILM CAPACITOR	2AUPZTF471JE	1	376334714T	NSP
C1582	UPZ TYPE PLASTIC FILM CAPACITOR	2AUPZTF471JE	1	376334714T	NSP
C1641	UMXR TYPE PLASTIC FILM CAPACITOR	1JUMXRTF122JE	1	376591224T	N NSP
C1642	UMXR TYPE PLASTIC FILM CAPACITOR	1JUMXRTF122JE	1	376591224T	N NSP
C1901	UTSP TYPE ELECTROLYTIC CAPACITOR	CE04W25V-100M(UTSP)	1	397551017AT	N
C1902	UTSP TYPE ELECTROLYTIC CAPACITOR	CE04W25V-100M(UTSP)	1	397551017AT	N
C1903	UTSP TYPE ELECTROLYTIC CAPACITOR	CE04W25V-100M(UTSP)	1	397551017AT	N
C1904	UTSP TYPE ELECTROLYTIC CAPACITOR	CE04W25V-100M(UTSP)	1	397551017AT	N
C1911	CHIP TYPE CERAMIC CAPACITOR	CK725F1E-104Z1	1	332161040R1	NSP
C1922	CHIP TYPE CERAMIC CAPACITOR	CK725B1C-104K1	1	332121045R1	NSP
C1923	CHIP TYPE CERAMIC CAPACITOR	CC725CH1H-080D1	1	342100802R1	NSP
C1924	UTSP TYPE ELECTROLYTIC CAPACITOR	CE04W10V-220M(UTSP)	1	397532217AT	N
C1925	CHIP TYPE CERAMIC CAPACITOR	CK725F1E-104Z1	1	332161040R1	NSP
C1926	CHIP TYPE CERAMIC CAPACITOR	CK725F1E-104Z1	1	332161040R1	NSP
C1927	CHIP TYPE CERAMIC CAPACITOR	CC725CH1H-330J1	1	342103304R1	NSP
C1928	CHIP TYPE CERAMIC CAPACITOR	CK725F1E-104Z1	1	332161040R1	NSP
C1929	CHIP TYPE CERAMIC CAPACITOR	CC725CH1H-330J1	1	342103304R1	NSP
C2	CHIP TYPE CERAMIC CAPACITOR	CC725CH1H-220J1	1	342102204R1	NSP
C3	CHIP TYPE CERAMIC CAPACITOR	CK725B1H-332K1	1	332103325R1	NSP
C4	CHIP TYPE CERAMIC CAPACITOR	CC725CH1H-100D1	1	342101002R1	NSP
C5	CHIP TYPE CERAMIC CAPACITOR	CK725B1H-473K1	1	332104735R1	NSP
C5001	UPZ TYPE PLASTIC FILM CAPACITOR	2AUPZTF221JE	1	376332214T	NSP
C5002	UPZ TYPE PLASTIC FILM CAPACITOR	2AUPZTF221JE	1	376332214T	NSP
C5003	UPZ TYPE PLASTIC FILM CAPACITOR	2AUPZTF221JE	1	376332214T	NSP
C5021	UTSP TYPE ELECTROLYTIC CAPACITOR	CE04W50V 47M(UTSP)	1	397584707AT	N
C5022	UTSP TYPE ELECTROLYTIC CAPACITOR	CE04W50V 47M(UTSP)	1	397584707AT	N
C5023	UTSP TYPE ELECTROLYTIC CAPACITOR	CE04W50V 47M(UTSP)	1	397584707AT	N
C5081	UTSP TYPE ELECTROLYTIC CAPACITOR	CE04W50V-10M(UTSP)	1	397581007AT	N
C5082	UTSP TYPE ELECTROLYTIC CAPACITOR	CE04W50V-10M(UTSP)	1	397581007AT	N
C5083	UTSP TYPE ELECTROLYTIC CAPACITOR	CE04W50V-10M(UTSP)	1	397581007AT	N
C5481	UPZ TYPE PLASTIC FILM CAPACITOR	2AUPZTF101JE	1	376331014T	NSP
C5482	UPZ TYPE PLASTIC FILM CAPACITOR	2AUPZTF101JE	1	376331014T	NSP
C5483	UPZ TYPE PLASTIC FILM CAPACITOR	2AUPZTF101JE	1	376331014T	NSP
C5501	VR TYPE ELECTROLYTIC CAPACITOR	CE04W100V-22M(VR)	1	394692207T	
C5502	VR TYPE ELECTROLYTIC CAPACITOR	CE04W100V-22M(VR)	1	394692207T	
C5503	VR TYPE ELECTROLYTIC CAPACITOR	CE04W100V-22M(VR)	1	394692207T	
C5521	VR TYPE ELECTROLYTIC CAPACITOR	CE04W100V-22M(VR)	1	394692207T	
C5522	VR TYPE ELECTROLYTIC CAPACITOR	CE04W100V-22M(VR)	1	394692207T	
C5523	VR TYPE ELECTROLYTIC CAPACITOR	CE04W100V-22M(VR)	1	394692207T	
C5621	UMXR TYPE PLASTIC FILM CAPACITOR	1JUMXRTF103JE	1	376591034T	N NSP
C5622	UMXR TYPE PLASTIC FILM CAPACITOR	1JUMXRTF103JE	1	376591034T	N NSP
C5623	UMXR TYPE PLASTIC FILM CAPACITOR	1JUMXRTF103JE	1	376591034T	N NSP
C5641	UTSP TYPE ELECTROLYTIC CAPACITOR	CE04W50V 47M(UTSP)	1	397584707AT	N
C5642	UTSP TYPE ELECTROLYTIC CAPACITOR	CE04W50V 47M(UTSP)	1	397584707AT	N
C5643	UTSP TYPE ELECTROLYTIC CAPACITOR	CE04W50V 47M(UTSP)	1	397584707AT	N
C6	CHIP TYPE CERAMIC CAPACITOR	CK725B1H-222K1	1	332102225R1	NSP
C6301	UTSP TYPE ELECTROLYTIC CAPACITOR	CE04W50V 47M(UTSP)	1	397584707AT	N
C6302	UTSP TYPE ELECTROLYTIC CAPACITOR	CE04W50V 47M(UTSP)	1	397584707AT	N
C6303	UTSP TYPE ELECTROLYTIC CAPACITOR	CE04W50V 47M(UTSP)	1	397584707AT	N
C6401	CERAMIC CAPACITOR	CC45SL50V-040C	1	345020401T	NSP
C6402	CERAMIC CAPACITOR	CC45SL50V-040C	1	345020401T	NSP
C6403	CERAMIC CAPACITOR	CC45SL50V-040C	1	345020401T	NSP
C6421	UTSP TYPE ELECTROLYTIC CAPACITOR	CE04W25V-220M(UTSP)	1	397552217T	
C6422	UTSP TYPE ELECTROLYTIC CAPACITOR	CE04W25V-220M(UTSP)	1	397552217T	

C6423	UTSP TYPE ELECTROLYTIC CAPACITOR	CE04W25V-220M(UTSP)	1	397552217T	
C7	CHIP TYPE CERAMIC CAPACITOR	CK725B1A-105K1	1	332131055R1	NSP
C7500	UTSP TYPE ELECTROLYTIC CAPACITOR	CE04W50V-10M(UTSP)	1	397581007AT	N
C7501	CHIP TYPE CERAMIC CAPACITOR	CK725B1H-223K1	1	332102235R1	NSP
C7502	UTSP TYPE ELECTROLYTIC CAPACITOR	CE04W25V-100M(UTSP)	1	397551017AT	N
C7550	CHIP TYPE CERAMIC CAPACITOR	CK725F1E-104Z1	1	332161040R1	NSP
C7740	CHIP TYPE CERAMIC CAPACITOR	CK725B1H-103K1	1	332101035R1	NSP
C7741	CHIP TYPE CERAMIC CAPACITOR	CK725B1H-103K1	1	332101035R1	NSP
C7770	CHIP TYPE CERAMIC CAPACITOR	CK725B1H-103K1	1	332101035R1	NSP
C7771	CHIP TYPE CERAMIC CAPACITOR	CK725B1H-103K1	1	332101035R1	NSP
C7774	CHIP TYPE CERAMIC CAPACITOR	CK725B1H-103K1	1	332101035R1	NSP
C7775	CHIP TYPE CERAMIC CAPACITOR	CK725B1H-103K1	1	332101035R1	NSP
C7780	UTSP TYPE ELECTROLYTIC CAPACITOR	CE04W50V-10M(UTSP)	1	397581007AT	N
C7781	CHIP TYPE CERAMIC CAPACITOR	CC725CH1H-102J1	1	342101024R1	NSP
C7801	CHIP TYPE CERAMIC CAPACITOR	CC725CH1H-471J1	1	342104714R1	NSP
C7802	CHIP TYPE CERAMIC CAPACITOR	CC725CH1H-471J1	1	342104714R1	NSP
C7809	CHIP TYPE CERAMIC CAPACITOR	CK725F1E-104Z1	1	332161040R1	NSP
C7850	UTSP TYPE ELECTROLYTIC CAPACITOR	CE04W50V-10M(UTSP)	1	397581007AT	N
C7851	CHIP TYPE CERAMIC CAPACITOR	CC725CH1H-101J1	1	342101014R1	NSP
C7853	UTSP TYPE ELECTROLYTIC CAPACITOR	CE04W25V-47M(UTSP)	1	397554707AT	N
C7854	UTSP TYPE ELECTROLYTIC CAPACITOR	CE04W25V-47M(UTSP)	1	397554707AT	N
C7855	CHIP TYPE CERAMIC CAPACITOR	CC725CH1H-330J1	1	342103304R1	NSP
C7856	UTSP TYPE ELECTROLYTIC CAPACITOR	CE04W50V-10M(UTSP)	1	397581007AT	N
C7857	CHIP TYPE CERAMIC CAPACITOR	CK725F1E-104Z1	1	332161040R1	NSP
C7858	CHIP TYPE CERAMIC CAPACITOR	CC725CH1H-102J1	1	342101024R1	NSP
C7880	CHIP TYPE CERAMIC CAPACITOR	CK725B1H-103K1	1	332101035R1	NSP
C7881	UPZ TYPE PLASTIC FILM CAPACITOR	2AUPZTF221JE	1	376332214T	NSP
C7882	UPZ TYPE PLASTIC FILM CAPACITOR	2AUPZTF221JE	1	376332214T	NSP
C7883	CHIP TYPE CERAMIC CAPACITOR	CC725CH1H-102J1	1	342101024R1	NSP
C7884	CHIP TYPE CERAMIC CAPACITOR	CC725CH1H-102J1	1	342101024R1	NSP
C7900	JAMICON TYPE ELECTROLYTIC CAPACIT	CE04W63V-47M	1	398574707T	
C7900or	VR TYPE ELECTROLYTIC CAPACITOR	CE04W63V-47M(VR)	(1)	394674707T	
C7901	JAMICON TYPE ELECTROLYTIC CAPACIT	CE04W50V-47M	1	398584707T	
C7901or	VR TYPE ELECTROLYTIC CAPACITOR	CE04W50V-47M(VR)	(1)	394684707T	
C7902	JAMICON TYPE ELECTROLYTIC CAPACIT	CE04W50V-47M	1	398584707T	
C7902or	VR TYPE ELECTROLYTIC CAPACITOR	CE04W50V-47M(VR)	(1)	394684707T	
C7903	CHIP TYPE CERAMIC CAPACITOR	CK725B1H-223K1	1	332102235R1	NSP
C7904	CHIP TYPE CERAMIC CAPACITOR	CK725B1H-223K1	1	332102235R1	NSP
C7905	UTSP TYPE ELECTROLYTIC CAPACITOR	CE04W25V-47M(UTSP)	1	397554707AT	N
C7907	CHIP TYPE CERAMIC CAPACITOR	CK725B1H-223K1	1	332102235R1	NSP
C7908	CHIP TYPE CERAMIC CAPACITOR	CK725B1H-473K1	1	332104735R1	NSP
C7909	CHIP TYPE CERAMIC CAPACITOR	CK725F1H-104Z1	1	332151040R1	NSP
C7910	CHIP TYPE CERAMIC CAPACITOR	CC725CH1H-101J1	1	342101014R1	NSP
C7911	CHIP TYPE CERAMIC CAPACITOR	CC725CH1H-101J1	1	342101014R1	NSP
C7912	CHIP TYPE CERAMIC CAPACITOR	CC725CH1H-101J1	1	342101014R1	NSP
C7913	CHIP TYPE CERAMIC CAPACITOR	CC725CH1H-101J1	1	342101014R1	NSP
C7914	CHIP TYPE CERAMIC CAPACITOR	CK725F1E-104Z1	1	332161040R1	NSP
C7915	CHIP TYPE CERAMIC CAPACITOR	CK725B1H-223K1	1	332102235R1	NSP
C7916	CHIP TYPE CERAMIC CAPACITOR	CK725B1H-223K1	1	332102235R1	NSP
C8	CHIP TYPE CERAMIC CAPACITOR	CK725B1A-105K1	1	332131055R1	NSP
C9	CHIP TYPE CERAMIC CAPACITOR	CK732B16V-106K	1	332071065R2	NSP
C9001	IS TYPE CAPACITOR	LE104-MX-C3.5	1	3800049S	!
C9002	ELECTROLYTIC CAPACITOR	CE04W200V-100M(KXJ)	1	3500233S	
C9003	PW TYPE ELECTROLYTIC CAPACITOR	CE04W50V-10M(PW)	1	393781007T	
C9004	PW TYPE ELECTROLYTIC CAPACITOR	CE04W25V-1000M(PW)	1	393751027S	

C9006	PW TYPE ELECTROLYTIC CAPACITOR	CE04W25V-470M(PW)	1	393754717T	
C9009	CHIP TYPE CERAMIC CAPACITOR	GRM31A7U3D220JW31D	1	3300071R1	N NSP
C9010	IS TYPE CAPACITOR	DE1E3KX102MB4BL01	1	3300066S	!
C9011	CHIP TYPE CERAMIC CAPACITOR	CK725B1C-104K1	1	332121045R1	NSP
C9012	IS TYPE CAPACITOR	LE103-C3.5	1	3800042S	!, N
C9012or	IS TYPE CAPACITOR	ECQU2A103MLC	(1)	3800039S	!
C9013	UTSP TYPE ELECTROLYTIC CAPACITOR	CE04W25V-220M(UTSP)	1	397552217T	
C9014	CHIP TYPE CERAMIC CAPACITOR	CK725B1H-103K1	1	332101035R1	NSP
C9015	CHIP TYPE CERAMIC CAPACITOR	CK725F1E-104Z1	1	332161040R1	NSP
C9016	CHIP TYPE CERAMIC CAPACITOR	CK725B1H-332K1	1	332103325R1	NSP
C9018	IS TYPE CAPACITOR	LE104-MX-C3.5	1	3800049S	!
C9019	IS TYPE CAPACITOR	DE1E3KX102MB4BL01	1	3300066S	!
C9023	CHIP TYPE CERAMIC CAPACITOR	CK725F1E-104Z1	1	332161040R1	NSP
C9024	CHIP TYPE CERAMIC CAPACITOR	CK725F1E-104Z1	1	332161040R1	NSP
C9025	IS TYPE CAPACITOR	DE1E3KX102MB4BL01	1	3300066S	!
[Resistors]					
R10	CHIP TYPE CARBON RESISTOR	RN72K1J-000JE	1	435030004R1	NSP
R11	CHIP TYPE CARBON RESISTOR	RN72K1J-000JE	1	435030004R1	NSP
R13	CHIP TYPE CARBON RESISTOR	RN72K1J-000JE	1	435030004R1	NSP
R14	CHIP TYPE CARBON RESISTOR	RN72K1J-000JE	1	435030004R1	NSP
R1501	CHIP TYPE CARBON RESISTOR	RN72K1J-821JE	1	435038214R1	NSP
R1502	CHIP TYPE CARBON RESISTOR	RN72K1J-821JE	1	435038214R1	NSP
R1503	CHIP TYPE CARBON RESISTOR	RN72K1J-332JE	1	435033324R1	NSP
R1504	CHIP TYPE CARBON RESISTOR	RN72K1J-332JE	1	435033324R1	NSP
R1505	CHIP TYPE CARBON RESISTOR	RN72K1J-332JE	1	435033324R1	NSP
R1506	CHIP TYPE CARBON RESISTOR	RN72K1J-332JE	1	435033324R1	NSP
R1507	CHIP TYPE CARBON RESISTOR	RN72K1J-332JE	1	435033324R1	NSP
R1508	CHIP TYPE CARBON RESISTOR	RN72K1J-332JE	1	435033324R1	NSP
R1521	CHIP TYPE CARBON RESISTOR	RN72K1J-821JE	1	435038214R1	NSP
R1522	CHIP TYPE CARBON RESISTOR	RN72K1J-821JE	1	435038214R1	NSP
R1523	CHIP TYPE CARBON RESISTOR	RN72K1J-332JE	1	435033324R1	NSP
R1524	CHIP TYPE CARBON RESISTOR	RN72K1J-332JE	1	435033324R1	NSP
R1525	CHIP TYPE CARBON RESISTOR	RN72K1J-332JE	1	435033324R1	NSP
R1526	CHIP TYPE CARBON RESISTOR	RN72K1J-332JE	1	435033324R1	NSP
R1527	CHIP TYPE CARBON RESISTOR	RN72K1J-332JE	1	435033324R1	NSP
R1528	CHIP TYPE CARBON RESISTOR	RN72K1J-332JE	1	435033324R1	NSP
R1541	CHIP TYPE CARBON RESISTOR	RN72K1J-152JE	1	435031524R1	NSP
R1542	CHIP TYPE CARBON RESISTOR	RN72K1J-152JE	1	435031524R1	NSP
R1543	CHIP TYPE CARBON RESISTOR	RN72K1J-332JE	1	435033324R1	NSP
R1544	CHIP TYPE CARBON RESISTOR	RN72K1J-332JE	1	435033324R1	NSP
R1545	CHIP TYPE CARBON RESISTOR	RN72K1J-332JE	1	435033324R1	NSP
R1546	CHIP TYPE CARBON RESISTOR	RN72K1J-332JE	1	435033324R1	NSP
R1547	CHIP TYPE CARBON RESISTOR	RN72K1J-332JE	1	435033324R1	NSP
R1548	CHIP TYPE CARBON RESISTOR	RN72K1J-332JE	1	435033324R1	NSP
R1561	CHIP TYPE CARBON RESISTOR	RN72K1J-152JE	1	435031524R1	NSP
R1562	CHIP TYPE CARBON RESISTOR	RN72K1J-152JE	1	435031524R1	NSP
R1563	CHIP TYPE CARBON RESISTOR	RN72K1J-332JE	1	435033324R1	NSP
R1564	CHIP TYPE CARBON RESISTOR	RN72K1J-332JE	1	435033324R1	NSP
R1565	CHIP TYPE CARBON RESISTOR	RN72K1J-332JE	1	435033324R1	NSP
R1566	CHIP TYPE CARBON RESISTOR	RN72K1J-332JE	1	435033324R1	NSP
R1567	CHIP TYPE CARBON RESISTOR	RN72K1J-332JE	1	435033324R1	NSP
R1568	CHIP TYPE CARBON RESISTOR	RN72K1J-332JE	1	435033324R1	NSP
R1581	CHIP TYPE CARBON RESISTOR	RN72K1J-472JE	1	435034724R1	NSP
R1582	CHIP TYPE CARBON RESISTOR	RN72K1J-472JE	1	435034724R1	NSP
R1583	CHIP TYPE CARBON RESISTOR	RN72K1J-121JE	1	435031214R1	NSP

R1887	CHIP TYPE CARBON RESISTOR	RN72K1J-470JE	1	435034704R1	NSP
R1888	CHIP TYPE CARBON RESISTOR	RN72K1J-470JE	1	435034704R1	NSP
R1901	CHIP TYPE CARBON RESISTOR	RN72K2E-220JE	1	435222204R1	NSP
R1902	CHIP TYPE CARBON RESISTOR	RN72K2E-220JE	1	435222204R1	NSP
R1903	CHIP TYPE CARBON RESISTOR	RN72K2E-220JE	1	435222204R1	NSP
R1904	CHIP TYPE CARBON RESISTOR	RN72K2E-220JE	1	435222204R1	NSP
R1921	CHIP TYPE CARBON RESISTOR	RN72K1J-750JE	1	435037504R1	NSP
R1922	CHIP TYPE CARBON RESISTOR	RN72K1J-100JE	1	435031004R1	NSP
R1924	CHIP TYPE CARBON RESISTOR	RN72K1J-823JE	1	435038234R1	NSP
R1925	CHIP TYPE CARBON RESISTOR	RN72K1J-103JE	1	435031034R1	NSP
R1926	CHIP TYPE CARBON RESISTOR	RN72K1J-470JE	1	435034704R1	NSP
R1927	CHIP TYPE CARBON RESISTOR	RN72K1J-470JE	1	435034704R1	NSP
R1950	CHIP TYPE CARBON RESISTOR	RN72K1J-000JE	1	435030004R1	NSP
R1951	CHIP TYPE CARBON RESISTOR	RN72K2E-000JE	1	435220004R1	NSP
R1952	CHIP TYPE CARBON RESISTOR	RN72K2E-000JE	1	435220004R1	NSP
R1953	CHIP TYPE CARBON RESISTOR	RN72K2E-000JE	1	435220004R1	NSP
R1954	CHIP TYPE CARBON RESISTOR	RN72K2E-000JE	1	435220004R1	NSP
R1958	CHIP TYPE CARBON RESISTOR	RN72K2E-000JE	1	435220004R1	NSP
R2	CHIP TYPE CARBON RESISTOR	RN72K1J-101JE	1	435031014R1	NSP
R21	CHIP TYPE CARBON RESISTOR	RN72K2E-000JE	1	435220004R1	NSP
R22	CHIP TYPE CARBON RESISTOR	RN72K2E-000JE	1	435220004R1	NSP
R3	EMI SUPPRESSION FILTER	BK1608HS601-T	1	230984R1	NSP
R4	EMI SUPPRESSION FILTER	BK1608HS601-T	1	230984R1	NSP
R5	CHIP TYPE CARBON RESISTOR	RN72K1J-103JE	1	435031034R1	NSP
R5001	CHIP TYPE CARBON RESISTOR	RN72K1J-152JE	1	435031524R1	NSP
R5002	CHIP TYPE CARBON RESISTOR	RN72K1J-152JE	1	435031524R1	NSP
R5003	CHIP TYPE CARBON RESISTOR	RN72K1J-152JE	1	435031524R1	NSP
R5021	CHIP TYPE CARBON RESISTOR	RN72K1J-563JE	1	435035634R1	NSP
R5022	CHIP TYPE CARBON RESISTOR	RN72K1J-563JE	1	435035634R1	NSP
R5023	CHIP TYPE CARBON RESISTOR	RN72K1J-563JE	1	435035634R1	NSP
R5041	CHIP TYPE CARBON RESISTOR	RN72K1J-331JE	1	435033314R1	NSP
R5042	CHIP TYPE CARBON RESISTOR	RN72K1J-331JE	1	435033314R1	NSP
R5043	CHIP TYPE CARBON RESISTOR	RN72K1J-331JE	1	435033314R1	NSP
R5061	METAL OXIDE FILM RESISTOR	RS1/2WBJ-100K	1	443521044T	N NSP
R5062	METAL OXIDE FILM RESISTOR	RS1/2WBJ-100K	1	443521044T	N NSP
R5063	METAL OXIDE FILM RESISTOR	RS1/2WBJ-100K	1	443521044T	N NSP
R5081	CHIP TYPE CARBON RESISTOR	RN72K1J-104JE	1	435031044R1	NSP
R5082	CHIP TYPE CARBON RESISTOR	RN72K1J-104JE	1	435031044R1	NSP
R5083	CHIP TYPE CARBON RESISTOR	RN72K1J-104JE	1	435031044R1	NSP
R5101	CHIP TYPE CARBON RESISTOR	RN72K1J-152JE	1	435031524R1	NSP
R5102	CHIP TYPE CARBON RESISTOR	RN72K1J-152JE	1	435031524R1	NSP
R5103	CHIP TYPE CARBON RESISTOR	RN72K1J-152JE	1	435031524R1	NSP
R5181	CHIP TYPE CARBON RESISTOR	RN72K1J-330JE	1	435033304R1	NSP
R5182	CHIP TYPE CARBON RESISTOR	RN72K1J-330JE	1	435033304R1	NSP
R5183	CHIP TYPE CARBON RESISTOR	RN72K1J-330JE	1	435033304R1	NSP
R5201	CHIP TYPE CARBON RESISTOR	RN72K1J-330JE	1	435033304R1	NSP
R5202	CHIP TYPE CARBON RESISTOR	RN72K1J-330JE	1	435033304R1	NSP
R5203	CHIP TYPE CARBON RESISTOR	RN72K1J-330JE	1	435033304R1	NSP
R5221	CHIP TYPE CARBON RESISTOR	RN72K1J-562JE	1	435035624R1	NSP
R5222	CHIP TYPE CARBON RESISTOR	RN72K1J-562JE	1	435035624R1	NSP
R5223	CHIP TYPE CARBON RESISTOR	RN72K1J-562JE	1	435035624R1	NSP
R5241	CHIP TYPE CARBON RESISTOR	RN72K1J-182JE	1	435031824R1	NSP
R5242	CHIP TYPE CARBON RESISTOR	RN72K1J-182JE	1	435031824R1	NSP
R5243	CHIP TYPE CARBON RESISTOR	RN72K1J-182JE	1	435031824R1	NSP
R5301	CHIP TYPE CARBON RESISTOR	RN72K1J-152JE	1	435031524R1	NSP

R5302	CHIP TYPE CARBON RESISTOR	RN72K1J-152JE	1	435031524R1	NSP
R5303	CHIP TYPE CARBON RESISTOR	RN72K1J-152JE	1	435031524R1	NSP
R5321	CHIP TYPE CARBON RESISTOR	RN72K1J-152JE	1	435031524R1	NSP
R5322	CHIP TYPE CARBON RESISTOR	RN72K1J-152JE	1	435031524R1	NSP
R5323	CHIP TYPE CARBON RESISTOR	RN72K1J-152JE	1	435031524R1	NSP
R5381	NON-FLAMMABLE CARBON FILM RESISTO R25J-220		1	415472214T	N
R5382	NON-FLAMMABLE CARBON FILM RESISTO R25J-220		1	415472214T	N
R5383	NON-FLAMMABLE CARBON FILM RESISTO R25J-220		1	415472214T	N
R5401	NON-FLAMMABLE CARBON FILM RESISTO R25J-220		1	415472214T	N
R5402	NON-FLAMMABLE CARBON FILM RESISTO R25J-220		1	415472214T	N
R5403	NON-FLAMMABLE CARBON FILM RESISTO R25J-220		1	415472214T	N
R5461	NON-FLAMMABLE CARBON FILM RESISTO R25J-39K		1	415473934T	N
R5462	NON-FLAMMABLE CARBON FILM RESISTO R25J-39K		1	415473934T	N
R5463	NON-FLAMMABLE CARBON FILM RESISTO R25J-39K		1	415473934T	N
R5481	NON-FLAMMABLE CARBON FILM RESISTO R25J-39K		1	415473934T	N
R5482	NON-FLAMMABLE CARBON FILM RESISTO R25J-39K		1	415473934T	N
R5483	NON-FLAMMABLE CARBON FILM RESISTO R25J-39K		1	415473934T	N
R5501	NON-FLAMMABLE CARBON FILM RESISTO R25J-10		1	415471004T	
R5502	NON-FLAMMABLE CARBON FILM RESISTO R25J-10		1	415471004T	
R5503	NON-FLAMMABLE CARBON FILM RESISTO R25J-10		1	415471004T	
R5521	NON-FLAMMABLE CARBON FILM RESISTO R25J-10		1	415471004T	
R5522	NON-FLAMMABLE CARBON FILM RESISTO R25J-10		1	415471004T	
R5523	NON-FLAMMABLE CARBON FILM RESISTO R25J-10		1	415471004T	
R5721	CHIP TYPE CARBON RESISTOR	RN72K1J-152FE	1	435031522R1	N NSP
R5722	CHIP TYPE CARBON RESISTOR	RN72K1J-152FE	1	435031522R1	N NSP
R5723	CHIP TYPE CARBON RESISTOR	RN72K1J-152FE	1	435031522R1	N NSP
R5741	CHIP TYPE CARBON RESISTOR	RN72K1J-152FE	1	435031522R1	N NSP
R5742	CHIP TYPE CARBON RESISTOR	RN72K1J-152FE	1	435031522R1	N NSP
R5743	CHIP TYPE CARBON RESISTOR	RN72K1J-152FE	1	435031522R1	N NSP
R5781	CHIP TYPE CARBON RESISTOR	RN72K1J-222FE	1	435032222R1	NSP
R5782	CHIP TYPE CARBON RESISTOR	RN72K1J-272FE	1	435032722R1	NSP
R5783	CHIP TYPE CARBON RESISTOR	RN72K1J-222FE	1	435032222R1	NSP
R5821	NON-FLAMMABLE CARBON FILM RESISTO R25J-2.2		1	415470224T	
R5822	NON-FLAMMABLE CARBON FILM RESISTO R25J-2.2		1	415470224T	
R5823	NON-FLAMMABLE CARBON FILM RESISTO R25J-2.2		1	415470224T	
R5881	CHIP TYPE CARBON RESISTOR	RN72K1J-000JE	1	435030004R1	NSP
R5882	CHIP TYPE CARBON RESISTOR	RN72K1J-000JE	1	435030004R1	NSP
R5883	CHIP TYPE CARBON RESISTOR	RN72K1J-000JE	1	435030004R1	NSP
R6	CHIP TYPE CARBON RESISTOR	RN72K1J-472JE	1	435034724R1	NSP
R6201	CHIP TYPE CARBON RESISTOR	RN72K1J-000JE	1	435030004R1	NSP
R6202	CHIP TYPE CARBON RESISTOR	RN72K1J-000JE	1	435030004R1	NSP
R6203	CHIP TYPE CARBON RESISTOR	RN72K1J-000JE	1	435030004R1	NSP
R6301	NON-FLAMMABLE CARBON FILM RESISTO R25J-150		1	415471514T	N
R6302	NON-FLAMMABLE CARBON FILM RESISTO R25J-150		1	415471514T	N
R6303	NON-FLAMMABLE CARBON FILM RESISTO R25J-150		1	415471514T	N
R6401	NON-FLAMMABLE CARBON FILM RESISTO R25J-56K		1	415475634T	N
R6402	NON-FLAMMABLE CARBON FILM RESISTO R25J-56K		1	415475634T	N
R6403	NON-FLAMMABLE CARBON FILM RESISTO R25J-56K		1	415475634T	N
R6421	CHIP TYPE CARBON RESISTOR	RN72K1J-182JE	1	435031824R1	NSP
R6422	CHIP TYPE CARBON RESISTOR	RN72K1J-182JE	1	435031824R1	NSP
R6423	CHIP TYPE CARBON RESISTOR	RN72K1J-182JE	1	435031824R1	NSP
R7	CHIP TYPE CARBON RESISTOR	RN72K1J-472JE	1	435034724R1	NSP
R7500	CHIP TYPE CARBON RESISTOR	RN72K1J-000JE	1	435030004R1	NSP
R7502	CHIP TYPE CARBON RESISTOR	RN72K1J-221JE	1	435032214R1	NSP
R7503	CHIP TYPE CARBON RESISTOR	RN72K1J-181JE	1	435031814R1	NSP

R7854	CHIP TYPE CARBON RESISTOR	RN72K1J-102JE	1	435031024R1	NSP
R7856	CHIP TYPE CARBON RESISTOR	RN72K1J-471JE	1	435034714R1	NSP
R7858	CHIP TYPE CARBON RESISTOR	RN72K1J-224JE	1	435032244R1	NSP
R7859	CHIP TYPE CARBON RESISTOR	RN72K1J-101JE	1	435031014R1	NSP
R7880	METAL OXIDE FILM RESISTOR	RS1/2WBJ-330	1	443523314T	N NSP
R7881	METAL OXIDE FILM RESISTOR	RS1/2WBJ-330	1	443523314T	N NSP
R7900	METAL RESISTOR	RNU1/2WCJ-8.2	1	453530824T	NSP
R7901	CHIP TYPE CARBON RESISTOR	RN72K1J-272JE	1	435032724R1	NSP
R7902	CHIP TYPE CARBON RESISTOR	RN72K1J-272JE	1	435032724R1	NSP
R7903	CHIP TYPE CARBON RESISTOR	RN72K1J-010JE	1	435030104R1	NSP
R7904	CHIP TYPE CARBON RESISTOR	RN72K1J-333JE	1	435033334R1	NSP
R7905	CHIP TYPE CARBON RESISTOR	RN72K1J-221JE	1	435032214R1	NSP
R7906	CHIP TYPE CARBON RESISTOR	RN72K1J-473JE	1	435034734R1	NSP
R7907	CHIP TYPE CARBON RESISTOR	RN72K1J-103JE	1	435031034R1	NSP
R7908	CHIP TYPE CARBON RESISTOR	RN72K1J-103JE	1	435031034R1	NSP
R7909	CHIP TYPE CARBON RESISTOR	RN72K1J-224JE	1	435032244R1	NSP
R7910	NON-FLAMMABLE CARBON FILM RESISTO	R25J-10	1	415471004T	
R7911	CHIP TYPE CARBON RESISTOR	RN72K1J-393JE	1	435033934R1	NSP
R7912	CHIP TYPE CARBON RESISTOR	RN72K1J-104JE	1	435031044R1	NSP
R7913	CHIP TYPE CARBON RESISTOR	RN72K1J-101JE	1	435031014R1	NSP
R7914	NON-FLAMMABLE CARBON FILM RESISTO	R25J-10	1	415471004T	
R7916	CHIP TYPE CARBON RESISTOR	RN72K1J-104JE	1	435031044R1	NSP
R7917	CHIP TYPE CARBON RESISTOR	RN72K1J-101JE	1	435031014R1	NSP
R7918	CHIP TYPE CARBON RESISTOR	RN72K1J-393JE	1	435033934R1	NSP
R7919	CHIP TYPE CARBON RESISTOR	RN72K1J-221JE	1	435032214R1	NSP
R7920	CHIP TYPE CARBON RESISTOR	RN72K1J-221JE	1	435032214R1	NSP
R7921	CHIP TYPE CARBON RESISTOR	RN72K1J-221JE	1	435032214R1	NSP
R7922	CHIP TYPE CARBON RESISTOR	RN72K1J-332JE	1	435033324R1	NSP
R7923	CHIP TYPE CARBON RESISTOR	RN72K1J-332JE	1	435033324R1	NSP
R7924	CHIP TYPE CARBON RESISTOR	RN72K1J-000JE	1	435030004R1	NSP
R8	CHIP TYPE CARBON RESISTOR	RN72K1J-101JE	1	435031014R1	NSP
R9	CHIP TYPE CARBON RESISTOR	RN72K1J-101JE	1	435031014R1	NSP
R9002	CHIP TYPE CARBON RESISTOR	RN72K1J-000JE	1	435030004R1	NSP
R9006	CHIP TYPE CARBON RESISTOR	RN72K1J-392JE	1	435033924R1	NSP
R9007	CHIP TYPE CARBON RESISTOR	RN72K1J-273FE	1	435032732R1	NSP
R9008	CHIP TYPE CARBON RESISTOR	RN72K1J-822JE	1	435038224R1	NSP
R9009	CHIP TYPE CARBON RESISTOR	RN72K1J-103JE	1	435031034R1	NSP
R9010	METAL OXIDE FILM RESISTOR	RS1/2WBJ-68	1	443526804T	N NSP
R9011	NON-FLAMMABLE CARBON FILM RESISTO	R25J-22	1	415472204T	
R9014	METAL RESISTOR	RNU1WCJ-1	1	453630104T	NSP
R9015	METAL OXIDE FILM RESISTOR	RS1/2WBJ-220	1	443522214T	NSP
R9017	CHIP TYPE CARBON RESISTOR	RN72K1J-332JE	1	435033324R1	NSP
R9018	CHIP TYPE CARBON RESISTOR	RN72K1J-182JE	1	435031824R1	NSP
R9022	CHIP TYPE CARBON RESISTOR	RN72K1J-152JE	1	435031524R1	NSP
R9023	CHIP TYPE CARBON RESISTOR	KTR18EZPF6803	1	435236842R1	NSP
R9024	CHIP TYPE CARBON RESISTOR	KTR18EZPF6803	1	435236842R1	NSP
R9025	CHIP TYPE CARBON RESISTOR	KTR18EZPF6803	1	435236842R1	NSP
R9031	METAL OXIDE FILM RESISTOR	RS1/2WBJ-47	1	443524704T	NSP
R9057	CHIP TYPE CARBON RESISTOR	RN72K1J-332JE	1	435033324R1	NSP
R9058	CHIP TYPE CARBON RESISTOR	RN72K1J-332JE	1	435033324R1	NSP
[Switches, Terminals, Wires]					
F9001	FUSE	T1A-SEUL-T250V	1	252397T	!
F9002C	FUSE HOLDER	NSCT-1P2031	1	25052133T	! NSP
F9002D	FUSE HOLDER	NSCT-1P2031	1	25052133T	! NSP
P0002A	PRINTED WIRING BOARD	BCDIS-1983	{1}	25141983	N NSP

P0002B	PRINTED WIRING BOARD	BCPS-1984	{1}	25141984	N	NSP
P0002C	PRINTED WIRING BOARD	BCDG-1985	{1}	25141985	N	NSP
P0002D	PRINTED WIRING BOARD	BCETC-1986	{1}	25141986	N	NSP
P0002E	PRINTED WIRING BOARD	BCRF-1987	{1}	25141987	N	NSP
P0002F	PRINTED WIRING BOARD	BCCLA-1988	{1}	25141988	N	NSP
P0002G	PRINTED WIRING BOARD	BCSW-1989	{1}	25141989	N	NSP
P020	PRINTED WIRING BOARD	BCDIS-1983	1	25141983A	N	NSP
P1	TERMINAL	NTM-1PDSC437	1	25060515	N	
P101A	SOCKET	NSCT-7P2100	1	25052203		NSP
P101B	SOCKET	NSCT-7P2100	1	25052203		NSP
P1501A	PLUG	IMSA-9142B-22A	1	25056601		NSP
P1502A	PLUG	IMSA-9142B-22A	1	25056601		NSP
P1511A	TERMINAL	NTM-1P233(M1969)	1	25060302		NSP
P1512A	TRM-423(SCREW)	NEJITANSI ST3	1	25060495		NSP
P1921	PIN JACK	NPJ-1PDO554	1	25045772		
P2	TERMINAL	NTM-2PDML439	1	25060517	N	
P5509B	RETAINER	(CLA-L)	1	27142312	N	NSP
P6001A	SOCKET	NSCT-9P2189	1	25052292		NSP
P6002A	SOCKET	NSCT-9P2189	1	25052292		NSP
P6003A	SOCKET	NSCT-9P2189	1	25052292		NSP
P7001B	SOCKET	9615S-31C-PP	1	25053319	N	NSP
P7550	RETAINER	(EARTH)TX-NR656	1	27142353	N	NSP
P7740A	WIRE HOL	CHD-1.5-5	1	25053536	N	NSP
P7740Aor	WIRE HOL	NSCT-5P876	(1)	25051089		NSP
P7740B	WIRE HOL	CHD-1.5-5	1	25053536	N	NSP
P7740Bor	WIRE HOL	NSCT-5P876	(1)	25051089		NSP
P7800	ST JACK	MSJ-035-05A BAG SR LF	1	25045927		
P7850	ST JACK	MSJ-035-05C B AG SR type	1	25045879		
P7880A	PLUG	NPLG-5P119	1	25055135		NSP
P7881	ST JACK	MSJ-064-05A SR	1	25045783		
P7900	PLUG	NPLG-5P220	1	25055236	N	NSP
P8002A	SOCKET	IMSA-9850S-30	1	25053215	N	NSP
P8003A	SOCKET	IMSA-9850S-30	1	25053215	N	NSP
P9001A	PLUG	NPLG-2P631	1	25055675		NSP
P9002	PLUG	NPLG-2P631	1	25055675		NSP
P9011	WIRE HARNESS ASSEMBLY	NSAS-5P2109	1	2009991298UL	N	NSP
P9011A	WIRE HOL	CHD-1.5-5	1	25053536	N	NSP
P9011Aor	WIRE HOL	NSCT-5P876	(1)	25051089		NSP
RL9001	RELAY	NRL-1P10A-DC9-188	1	25065693	!	
S7601	PUSH SWITCH	NPS-111-S681	1	25035718T		NSP
S7601or	PUSH SWITCH	NPS-111-S677	(1)	25035714T		NSP
S7605	PUSH SWITCH	NPS-111-S681	1	25035718T		NSP
S7605or	PUSH SWITCH	NPS-111-S677	(1)	25035714T		NSP
S7606	PUSH SWITCH	NPS-111-S681	1	25035718T		NSP
S7606or	PUSH SWITCH	NPS-111-S677	(1)	25035714T		NSP
S7607	PUSH SWITCH	NPS-111-S681	1	25035718T		NSP
S7607or	PUSH SWITCH	NPS-111-S677	(1)	25035714T		NSP
S7608	PUSH SWITCH	NPS-111-S681	1	25035718T		NSP
S7608or	PUSH SWITCH	NPS-111-S677	(1)	25035714T		NSP
S7609	PUSH SWITCH	NPS-111-S681	1	25035718T		NSP
S7609or	PUSH SWITCH	NPS-111-S677	(1)	25035714T		NSP
S7610	PUSH SWITCH	NPS-111-S681	1	25035718T		NSP
S7610or	PUSH SWITCH	NPS-111-S677	(1)	25035714T		NSP
S7611	PUSH SWITCH	NPS-111-S681	1	25035718T		NSP
S7611or	PUSH SWITCH	NPS-111-S677	(1)	25035714T		NSP

S7612	PUSH SWITCH	NPS-111-S681	1	25035718T	NSP
S7612or	PUSH SWITCH	NPS-111-S677	(1)	25035714T	NSP
S7613	PUSH SWITCH	NPS-111-S681	1	25035718T	NSP
S7613or	PUSH SWITCH	NPS-111-S677	(1)	25035714T	NSP
S7614	PUSH SWITCH	NPS-111-S681	1	25035718T	NSP
S7614or	PUSH SWITCH	NPS-111-S677	(1)	25035714T	NSP
S7615	PUSH SWITCH	NPS-111-S681	1	25035718T	NSP
S7615or	PUSH SWITCH	NPS-111-S677	(1)	25035714T	NSP
S7616	PUSH SWITCH	NPS-111-S681	1	25035718T	NSP
S7616or	PUSH SWITCH	NPS-111-S677	(1)	25035714T	NSP
S7617	PUSH SWITCH	NPS-111-S681	1	25035718T	NSP
S7617or	PUSH SWITCH	NPS-111-S677	(1)	25035714T	NSP
S7618	PUSH SWITCH	NPS-111-S681	1	25035718T	NSP
S7618or	PUSH SWITCH	NPS-111-S677	(1)	25035714T	NSP
S7619	PUSH SWITCH	NPS-111-S681	1	25035718T	NSP
S7619or	PUSH SWITCH	NPS-111-S677	(1)	25035714T	NSP
S7620	PUSH SWITCH	NPS-111-S681	1	25035718T	NSP
S7620or	PUSH SWITCH	NPS-111-S677	(1)	25035714T	NSP
S7621	PUSH SWITCH	NPS-111-S681	1	25035718T	NSP
S7621or	PUSH SWITCH	NPS-111-S677	(1)	25035714T	NSP
S7622	PUSH SWITCH	NPS-111-S681	1	25035718T	NSP
S7622or	PUSH SWITCH	NPS-111-S677	(1)	25035714T	NSP
S7623	PUSH SWITCH	NPS-111-S681	1	25035718T	NSP
S7623or	PUSH SWITCH	NPS-111-S677	(1)	25035714T	NSP
S7624	PUSH SWITCH	NPS-111-S681	1	25035718T	NSP
S7624or	PUSH SWITCH	NPS-111-S677	(1)	25035714T	NSP
S7625	PUSH SWITCH	NPS-111-S681	1	25035718T	NSP
S7625or	PUSH SWITCH	NPS-111-S677	(1)	25035714T	NSP
S7626	PUSH SWITCH	NPS-111-S681	1	25035718T	NSP
S7626or	PUSH SWITCH	NPS-111-S677	(1)	25035714T	NSP
S7627	PUSH SWITCH	NPS-111-S681	1	25035718T	NSP
S7627or	PUSH SWITCH	NPS-111-S677	(1)	25035714T	NSP
S7631	PUSH SWITCH	NPS-111-S681	1	25035718T	NSP
S7631or	PUSH SWITCH	NPS-111-S677	(1)	25035714T	NSP
S7632	PUSH SWITCH	NPS-111-S681	1	25035718T	NSP
S7632or	PUSH SWITCH	NPS-111-S677	(1)	25035714T	NSP
S7700	ROTARY ENCODER	XREB12504PVB30FINB1-2-24	1	25065729	N
S7740	ROTARY ENCODER	XREB125(9X11.5)PVB30FINB1	1	25065737	N
S7740or	ROTARY ENCODER	EVEHD1F3024B	(1)	25065695W	
S7774	ROTARY ENCODER	XREB125(9X11.5)PVB30FINB1	1	25065737	N
S7774or	ROTARY ENCODER	EVEHD1F3024B	(1)	25065695W	
[Frontend, Units]					
BADIS-1983	Display circuit pc board AS	BADIS-1983-1A	1	1B5141983-1A-C	Child
BAPS-1984	Power supply circuit pc board AS	BAPS-1984-1A	1	1B5141984-1A-C	Child
BADG-1985	Digital circuit pc board AS	BADG-1985-1A	1	1B5141985-1A-C	Child
BAETC-1986	Et cetra pc board AS	BAETC-1986-1A	1	1B5141986-1A-C	Child
BARF-1987	Radio frequency circuit pc board AS	BARF-1987-1A	1	1B5141987-1A-C	Child
BACLA-1988	ClassA amplifier circuit pc board AS	BACLA-1988-1A	1	1B5141988-1A-C	Child
BASW-1989	Switch circuit pc board AS	BASW-1989-1A	1	1B5141989-1A-C	Child

BAPRC-2034-1A**<Note>**

Parts marked by "NSP" are generally unavailable because they are not in our Master Spare Parts List.

<Notes>

█ : NSP

NOTE : THE COMPONENTS IDENTIFIED BY THE MARK ! ARE CRITICAL FOR RISK OF FIRE AND ELECTRIC SHOCK. REPLACE ONLY WITH PART

REF. NO.	PART NAME	DESCRIPTION	Q'TY	PART NO. (SN)	REMARKS
[Semi-conductors]					
D1005	CHIP TYPE DIODE	DA2J10100	1	223303R2	NSP
D1005or	CHIP TYPE DIODE	1SS352	(1)	223234R2	NSP
D3000	CHIP TYPE DIODE	DA2J10100	1	223303R2	NSP
D3000or	CHIP TYPE DIODE	1SS352	(1)	223234R2	NSP
D3001	CHIP TYPE DIODE	DA2J10100	1	223303R2	NSP
D3001or	CHIP TYPE DIODE	1SS352	(1)	223234R2	NSP
D3002	CHIP TYPE DIODE	DA2J10100	1	223303R2	NSP
D3002or	CHIP TYPE DIODE	1SS352	(1)	223234R2	NSP
D3003	CHIP TYPE DIODE	DA2J10100	1	223303R2	NSP
D3003or	CHIP TYPE DIODE	1SS352	(1)	223234R2	NSP
D7001	CHIP TYPE DIODE	DA2J10100	1	223303R2	NSP
D7001or	CHIP TYPE DIODE	1SS352	(1)	223234R2	NSP
D7002	CHIP TYPE DIODE	DA2J10100	1	223303R2	NSP
D7002or	CHIP TYPE DIODE	1SS352	(1)	223234R2	NSP
D7003	CHIP TYPE DIODE	DA2J10100	1	223303R2	NSP
D7003or	CHIP TYPE DIODE	1SS352	(1)	223234R2	NSP
D7004	CHIP TYPE DIODE	DA2J10100	1	223303R2	NSP
D7004or	CHIP TYPE DIODE	1SS352	(1)	223234R2	NSP
D7006	DIODE	CUS357	1	223320R2	N NSP
D7009	CHIP TYPE DIODE	DA2J10100	1	223303R2	NSP
D7009or	CHIP TYPE DIODE	1SS352	(1)	223234R2	NSP
D8003	ESD	IMSA-6802-01Y901_1608SIZE	1	4000255AR1	N NSP
D8301	ZENER DIODE	DZ2J036M0L	1	224760360R2	NSP
D8900	DIODE	CUS357	1	223320R2	N NSP
D8901	DIODE	CUS357	1	223320R2	N NSP
D8902	DIODE	CUS357	1	223320R2	N NSP
D8907	CHIP TYPE DIODE	DA2J10100	1	223303R2	NSP
D8907or	CHIP TYPE DIODE	1SS352	(1)	223234R2	NSP
D8909	CHIP TYPE DIODE	DA2J10100	1	223303R2	NSP
D8909or	CHIP TYPE DIODE	1SS352	(1)	223234R2	NSP
D8942	CHIP TYPE DIODE	DA2J10100	1	223303R2	NSP
D8942or	CHIP TYPE DIODE	1SS352	(1)	223234R2	NSP
D8943	CHIP TYPE DIODE	DA2J10100	1	223303R2	NSP
D8943or	CHIP TYPE DIODE	1SS352	(1)	223234R2	NSP
D8963	DIODE	RBR3MM30ATR	1	22380401R2	N NSP
D8968	CHIP TYPE DIODE	DA2J10100	1	223303R2	NSP
D8968or	CHIP TYPE DIODE	1SS352	(1)	223234R2	NSP
D8969	ZENER DIODE	DZ2J062M0L	1	224760620R2	NSP
Q1001	HYBRID IC	TC7SZU04FU	1	22242512R2TO	NSP
Q1002	HYBRID IC	PCM5101APWR	1	22242855R2	N NSP
Q1004	HYBRID IC	AK4458VN	1	22242927R2	N NSP
Q1005	HYBRID IC	PCM9211PTR	1	22242703R2	NSP
Q1007	HYBRID IC	74VHC4040FT	1	22274040E1R2TO	N NSP
Q1008	HYBRID IC	TC7WH241FU(TE12L_F)	1	22242076R2TO	NSP

Q1090	HYBRID IC	MM3464A50NRE	1	22243073R2	N	NSP
Q1091	HYBRID IC	S-1333A33-M5T1U3	1	22242934R2	N	NSP
Q1092	HYBRID IC	74LCX125FT	1	22274125BR2TO		NSP
Q1094	HYBRID IC	74LCX125FT	1	22274125BR2TO		NSP
Q1095	TRANSISTOR	DTC044EEBTL	1	2218700R2	N	NSP
Q1095or	TRANSISTOR	KRC404E	(1)	2216450R2		NSP
Q1097	HYBRID IC	74VHC541FT	1	22274541E1R2TO	N	NSP
Q1099	TRANSISTOR	DTC044EEBTL	1	2218700R2	N	NSP
Q1099or	TRANSISTOR	KRC404E	(1)	2216450R2		NSP
Q3001	HYBRID IC	AM3354BZCZ80	1	22243021R3	N	NSP
Q3002	HYBRID IC	TC58NVG1S3HTA00B4H	1	222W0155R3	N	NSP
Q3003	HYBRID IC	NT5CC128M16IP-DI	1	22243076R3	N	NSP
Q3006	HYBRID IC	PST894A160UR	1	22243226R2	N	NSP
Q3007	TRANSISTOR	DTC014EEBTL	1	2218690R2	N	NSP
Q3007or	TRANSISTOR	KRC402E	(1)	2218330R2		NSP
Q3201	HYBRID IC	MFI337S3959	1	22242820R2	N	NSP
Q3401	HYBRID IC	W25Q32FVSSIG	1	222W0135R2	N	NSP
Q3403	HYBRID IC	TC7SZU04FU	1	22242512R2TO		NSP
Q3404	HYBRID IC	CS49844A-CQZ	1	22242926R3	N	NSP
Q3406	HYBRID IC	A3V64S40GTP-60	1	22242976R2	N	NSP
Q3406or	HYBRID IC	M12L64164A-7TG2Y	(1)	22242951R3		NSP
Q3410	TRANSISTOR	DTC014EEBTL	1	2218690R2	N	NSP
Q3410or	TRANSISTOR	KRC402E	(1)	2218330R2		NSP
Q3601	HYBRID IC	FP6861C-B1AS5CT	1	22242840R2	N	NSP
Q3651	HYBRID IC	KSZ8091RNB	1	22243023R2	N	NSP
Q3652	HYBRID IC	SN74AUP1T17DCKR	1	222740170R2	N	NSP
Q3653	HYBRID IC	SN74AUP1T17DCKR	1	222740170R2	N	NSP
Q3654	HYBRID IC	TC74VCX125FT	1	22274125DR2TO	N	NSP
Q3667	TRANSISTOR	DTC014EEBTL	1	2218690R2	N	NSP
Q3667or	TRANSISTOR	KRC402E	(1)	2218330R2		NSP
Q3901	HYBRID IC	TPS65910A31A1RSLR	1	22243022R2	N	NSP
Q7001	HYBRID IC	M95640-WMN6TP	1	22242643R2		NSP
Q7001or	HYBRID IC	BR25S640FJ	(1)	22242761R2		NSP
Q7002	TRANSISTOR	DTA014EEBTL	1	2218680R2	N	NSP
Q7002or	TRANSISTOR	KRA302E	(1)	2218360R2		NSP
Q7003	TRANSISTOR	DTA014EEBTL	1	2218680R2	N	NSP
Q7004	TRANSISTOR	DTA014EEBTL	1	2218680R2	N	NSP
Q7005	TRANSISTOR	DTC044EEBTL	1	2218700R2	N	NSP
Q7005or	TRANSISTOR	KRC404E	(1)	2216450R2		NSP
Q7006	TRANSISTOR	DTC044EEBTL	1	2218700R2	N	NSP
Q7007	TRANSISTOR	DTC044EEBTL	1	2218700R2	N	NSP
Q7009	HYBRID IC	MPD70F3477AGJA-GAE-G	1	222W0117R3		NSP
Q7013	HYBRID IC	TC7WBL3305CFK	1	22242965R2	N	NSP
Q7016	TRANSISTOR	2SC2712-GR	1	2213145R2		NSP
Q7017	TRANSISTOR	DTC014EEBTL	1	2218690R2	N	NSP
Q7017or	TRANSISTOR	KRC402E	(1)	2218330R2		NSP
Q7018	HYBRID IC	S-1333A33-M5T1U3	1	22242934R2	N	NSP
Q7020	HYBRID IC	PST894A270UR	1	22243198R2	N	NSP
Q7027	HYBRID IC	S-1333A33-M5T1U3	1	22242934R2	N	NSP
Q7033	TRANSISTOR	DTC023JEBTL	1	2218710R2	N	NSP
Q7033or	TRANSISTOR	KRC405E	(1)	2218340R2		NSP
Q8003	HYBRID IC	74LCX125FT	1	22274125BR2TO		NSP
Q8004	TRANSISTOR	2SA1162-GR	1	2214375R2		NSP
Q8005	TRANSISTOR	DTC044EEBTL	1	2218700R2	N	NSP
Q8005or	TRANSISTOR	KRC404E	(1)	2216450R2		NSP

Q8114	HYBRID IC	74LCX125FT	1	22274125BR2TO	NSP
Q8202	HYBRID IC	ADV7180KCP32Z-RL	1	22242763R2	N NSP
Q8203	HYBRID IC	MM3411A18URE	1	22243075R2	N NSP
Q8205	HYBRID IC	MM3411A18URE	1	22243075R2	N NSP
Q8300	HYBRID IC	S-13A1A13-U5T1U3	1	22242848R2	N NSP
Q8302	HYBRID IC	SII9573CTUC	1	22242762R3	NSP
Q8303	TRANSISTOR	2SA1162-GR	1	2214375R2	NSP
Q8307	HYBRID IC	MM3411A13URE	1	22243074R2	N NSP
Q8401	HYBRID IC	MN864787	1	22242944R3	N NSP
Q8402	HYBRID IC	MX25L6433FM2I-08G	1	222W0156R2	N NSP
Q8402or	HYBRID IC	IS25LP064A-JBLE	(1)	222W0160R2	NSP
Q8701	HYBRID IC	TMPM361F10FG	1	222W0115R3	NSP
Q8702	TRANSISTOR	DTC014EEBTL	1	2218690R2	N NSP
Q8702or	TRANSISTOR	KRC402E	(1)	2218330R2	NSP
Q8703	TRANSISTOR	RE1C001UNTCL	1	2218160R2	N NSP
Q8704	TRANSISTOR	DTA014EEBTL	1	2218680R2	N NSP
Q8704or	TRANSISTOR	KRA302E	(1)	2218360R2	NSP
Q8705	TRANSISTOR	DTC014EEBTL	1	2218690R2	N NSP
Q8705or	TRANSISTOR	KRC402E	(1)	2218330R2	NSP
Q8709	TRANSISTOR	DTC014EEBTL	1	2218690R2	N NSP
Q8709or	TRANSISTOR	KRC402E	(1)	2218330R2	NSP
Q8710	TRANSISTOR	DTC014EEBTL	1	2218690R2	N NSP
Q8710or	TRANSISTOR	KRC402E	(1)	2218330R2	NSP
Q8712	TRANSISTOR	DTC014EEBTL	1	2218690R2	N NSP
Q8712or	TRANSISTOR	KRC402E	(1)	2218330R2	NSP
Q8713	TRANSISTOR	DTC014EEBTL	1	2218690R2	N NSP
Q8713or	TRANSISTOR	KRC402E	(1)	2218330R2	NSP
Q8715	TRANSISTOR	DTA014EEBTL	1	2218680R2	N NSP
Q8715or	TRANSISTOR	KRA302E	(1)	2218360R2	NSP
Q8716	TRANSISTOR	DTC014EEBTL	1	2218690R2	N NSP
Q8716or	TRANSISTOR	KRC402E	(1)	2218330R2	NSP
Q8725	TRANSISTOR	DTC014EEBTL	1	2218690R2	N NSP
Q8725or	TRANSISTOR	KRC402E	(1)	2218330R2	NSP
Q8727	TRANSISTOR	DTC014EEBTL	1	2218690R2	N NSP
Q8727or	TRANSISTOR	KRC402E	(1)	2218330R2	NSP
Q8729	TRANSISTOR	DTC014EEBTL	1	2218690R2	N NSP
Q8729or	TRANSISTOR	KRC402E	(1)	2218330R2	NSP
Q8730	TRANSISTOR	DTC014EEBTL	1	2218690R2	N NSP
Q8730or	TRANSISTOR	KRC402E	(1)	2218330R2	NSP
Q8731	TRANSISTOR	DTC014EEBTL	1	2218690R2	N NSP
Q8731or	TRANSISTOR	KRC402E	(1)	2218330R2	NSP
Q8732	TRANSISTOR	DTC014EEBTL	1	2218690R2	N NSP
Q8732or	TRANSISTOR	KRC402E	(1)	2218330R2	NSP
Q8733	TRANSISTOR	DTC014EEBTL	1	2218690R2	N NSP
Q8733or	TRANSISTOR	KRC402E	(1)	2218330R2	NSP
Q8900	HYBRID IC	FP6861C-B1AS5CT	1	22242840R2	N NSP
Q8907	HYBRID IC	MM3464A50NRE	1	22243073R2	N NSP
Q8921	HYBRID IC	FR9888CSPCTR	1	22242839R2	N NSP
Q8931	HYBRID IC	FR9888CSPCTR	1	22242839R2	N NSP
Q8941	HYBRID IC	FR9888CSPCTR	1	22242839R2	N NSP
Q8946	HYBRID IC	TPS22924CZPZR	1	22242807R2	NSP
Q8951	HYBRID IC	FR9888CSPCTR	1	22242839R2	N NSP
Q8952	TRANSISTOR	2SC2712-GR	1	2213145R2	NSP
Q8961	HYBRID IC	FR9889SPCTR	1	22243033R2	N NSP
Q8965	HYBRID IC	MM3464A50NRE	1	22243073R2	N NSP

Q8967	HYBRID IC	FP6861C-B1AS5CT	1	22242840R2	N NSP
X1001	CRYSTAL	HC-49S 9C22.5792M	1	3010535R2	N NSP
X3001	CRYSTAL	HC-49S 9C24.0000M	1	3010515R2	NSP
X3002	CRYSTAL	FC-135 -32.768K	1	3010532R2	N NSP
X3401	CRYSTAL	HC-49S 9C24.5760M	1	3010516R2	NSP
X3651	CRYSTAL	HC-49S 9C25.0000M	1	3010517R2	NSP
X7001	CRYSTAL	CSTCR4M00G53-R0	1	3010536R2	N NSP
X8201	CRYSTAL	HC-49S 9C28.6363M	1	3010519R2	NSP
X8301	CRYSTAL	HC-49S 9C27.0000M	1	3010518R2	NSP
X8400	CRYSTAL	HC-49S 9C27.0000M	1	3010518R2	NSP
X8701	CERAMIC RESONATOR	CSTCE8M00G55-R0	1	3010416R2	NSP
[Transformers, Coils]					
L1000	CORE	BLM15PX181SN1D	1	2350033R1	N NSP
L1001	CORE	BLM15PX181SN1D	1	2350033R1	N NSP
L1004	CORE	BK1005LL241-T	1	2350032R1	N NSP
L1005	CORE	BK1005LL241-T	1	2350032R1	N NSP
L1006	CORE	BK1005LL241-T	1	2350032R1	N NSP
L1007	CORE	BK1005LL241-T	1	2350032R1	N NSP
L1009	CHOKE COIL	LBC2518T4R7M	1	231364M047R2	NSP
L1010	CHOKE COIL	LBC2518T4R7M	1	231364M047R2	NSP
L1011	CHOKE COIL	LBC2518T4R7M	1	231364M047R2	NSP
L1012	CHOKE COIL	LBC2518T4R7M	1	231364M047R2	NSP
L1013	CHOKE COIL	LBC2518T4R7M	1	231364M047R2	NSP
L1018	CORE	BLM15PX181SN1D	1	2350033R1	N NSP
L1019	CORE	BLM15PX181SN1D	1	2350033R1	N NSP
L1027	CORE	BK1005LL241-T	1	2350032R1	N NSP
L3001	CORE	BLM15PX121SN1D	1	2350034R1	N NSP
L3201	CORE	BK1005LL241-T	1	2350032R1	N NSP
L3202	CORE	BK1005LL241-T	1	2350032R1	N NSP
L3401	CORE	BLM15PX181SN1D	1	2350033R1	N NSP
L3403	CORE	BK1005LL241-T	1	2350032R1	N NSP
L3405	CORE	BLM15PX121SN1D	1	2350034R1	N NSP
L3406	CORE	BLM15PX330SN1D	1	2350043R1	N NSP
L3407	CORE	BLM15PX121SN1D	1	2350034R1	N NSP
L3408	CORE	BLM15PX121SN1D	1	2350034R1	N NSP
L3409	CORE	BLM15PX181SN1D	1	2350033R1	N NSP
L3411	CORE	BK1005LL241-T	1	2350032R1	N NSP
L3601	CORE	BLM15PX121SN1D	1	2350034R1	N NSP
L3602	CORE	BLM15PX121SN1D	1	2350034R1	N NSP
L3611	CORE	MCF12102G900-T	1	2350041R2	N NSP
L3613	CORE	MCF20104G900-T	1	2350040R2	N NSP
L3651	CORE	BLM15PX121SN1D	1	2350034R1	N NSP
L3652	CORE	BLM15PX121SN1D	1	2350034R1	N NSP
L3655	CORE	BLM15PX121SN1D	1	2350034R1	N NSP
L3656	CORE	BLM15PX121SN1D	1	2350034R1	N NSP
L3661	CORE	BLM15PX121SN1D	1	2350034R1	N NSP
L3901	CHOKE COIL	NRS4018T2R2MDGJ	1	231494R2	N NSP
L3902	CHOKE COIL	NRS4018T2R2MDGJ	1	231494R2	N NSP
L3903	CHOKE COIL	NRS4018T2R2MDGJ	1	231494R2	N NSP
L3904	CORE	BLM15PX121SN1D	1	2350034R1	N NSP
L3905	CORE	BLM15PX121SN1D	1	2350034R1	N NSP
L3906	CORE	BLM15PX121SN1D	1	2350034R1	N NSP
L3907	CORE	BLM15PX121SN1D	1	2350034R1	N NSP
L3909	CORE	BLM15PX121SN1D	1	2350034R1	N NSP
L3910	CORE	BLM15PX121SN1D	1	2350034R1	N NSP

L3911	CORE	BLM15PX121SN1D	1	2350034R1	N NSP
L7003	CORE	BLM15PX181SN1D	1	2350033R1	N NSP
L7007	CORE	BLM15PX181SN1D	1	2350033R1	N NSP
L8001	CORE	EXC24CH900U	1	2350039R2	N NSP
L8002	CORE	EXC24CH900U	1	2350039R2	N NSP
L8003	CORE	EXC24CH900U	1	2350039R2	N NSP
L8004	CORE	EXC24CH900U	1	2350039R2	N NSP
L8202	CORE	BLM15PX181SN1D	1	2350033R1	N NSP
L8205	CORE	BLM15PX181SN1D	1	2350033R1	N NSP
L8207	CORE	BLM15PX181SN1D	1	2350033R1	N NSP
L8210	CORE	BLM15PX181SN1D	1	2350033R1	N NSP
L8302	CORE	BLM15PX181SN1D	1	2350033R1	N NSP
L8303	CORE	BLM15PX181SN1D	1	2350033R1	N NSP
L8304	CORE	BLM15PX181SN1D	1	2350033R1	N NSP
L8305	CORE	BLM15PX181SN1D	1	2350033R1	N NSP
L8306	CORE	BLM15PX181SN1D	1	2350033R1	N NSP
L8307	CORE	BLM15PX181SN1D	1	2350033R1	N NSP
L8308	CORE	BLM15PX181SN1D	1	2350033R1	N NSP
L8400	CORE	BLM15PX121SN1D	1	2350034R1	N NSP
L8401	CORE	BLM15PX121SN1D	1	2350034R1	N NSP
L8402	CORE	BLM15PX121SN1D	1	2350034R1	N NSP
L8403	CORE	BLM15PX121SN1D	1	2350034R1	N NSP
L8404	CORE	BLM15PX121SN1D	1	2350034R1	N NSP
L8405	CORE	BLM15PX121SN1D	1	2350034R1	N NSP
L8406	CORE	BLM15PX121SN1D	1	2350034R1	N NSP
L8407	CORE	BLM15PX121SN1D	1	2350034R1	N NSP
L8408	CORE	BLM15PX121SN1D	1	2350034R1	N NSP
L8409	CORE	BLM15PX121SN1D	1	2350034R1	N NSP
L8410	CORE	BLM15PX121SN1D	1	2350034R1	N NSP
L8411	CORE	BLM15PX121SN1D	1	2350034R1	N NSP
L8412	CORE	BLM15PX121SN1D	1	2350034R1	N NSP
L8413	CORE	BLM15PX121SN1D	1	2350034R1	N NSP
L8414	CORE	BLM15PX181SN1D	1	2350033R1	N NSP
L8415	CORE	BLM15PX121SN1D	1	2350034R1	N NSP
L8416	CORE	BK1005LL241-T	1	2350032R1	N NSP
L8417	CORE	BLM15PX181SN1D	1	2350033R1	N NSP
L8702	CORE	BLM15PX181SN1D	1	2350033R1	N NSP
L8921	CHOKE COIL	BLM21PG221SN1	1	230949R2	NSP
L8922	CHOKE COIL	1255AS-100M	1	231482M100R2	N NSP
L8923	CHOKE COIL	BLM21PG221SN1	1	230949R2	NSP
L8924	CHOKE COIL	BLM21PG221SN1	1	230949R2	NSP
L8931	CHOKE COIL	BLM21PG221SN1	1	230949R2	NSP
L8932	CHOKE COIL	1255AS-100M	1	231482M100R2	N NSP
L8941	CHOKE COIL	BLM21PG221SN1	1	230949R2	NSP
L8942	CHOKE COIL	1255AS-100M	1	231482M100R2	N NSP
L8951	CHOKE COIL	BLM21PG221SN1	1	230949R2	NSP
L8952	CHOKE COIL	1255AS-100M	1	231482M100R2	N NSP
L8953	CHOKE COIL	BLM21PG221SN1	1	230949R2	NSP
L8954	CHOKE COIL	BLM21PG221SN1	1	230949R2	NSP
L8961	CHOKE COIL	BLM21PG221SN1	1	230949R2	NSP
L8962	CHOKE COIL	1255AS-100M	1	231482M100R2	N NSP
L8965	CORE	BLM15PX181SN1D	1	2350033R1	N NSP
[Capacitors]					
C1001	CHIP TYPE CERAMIC CAPACITOR	CK725B1C-104K0	1	332011045R1	NSP
C1002	CHIP TYPE CERAMIC CAPACITOR	CK725B1H-104K1	1	332101045R1	N NSP

C1004	CHIP TYPE CERAMIC CAPACITOR	CK725B1H-104K1	1	332101045R1	N	NSP
C1005	CHIP ELECT C	CECS16V-100M	1	398641017R2	N	NSP
C1005or	CHIP ELECT C	CEWX16V-100M	(1)	398141017R2		NSP
C1006	CHIP TYPE CERAMIC CAPACITOR	CK725B1H-104K1	1	332101045R1	N	NSP
C1008	CHIP TYPE CERAMIC CAPACITOR	CC725CH1H-150J0	1	342031504R1		NSP
C1009	CHIP TYPE CERAMIC CAPACITOR	CC725CH1H-150J0	1	342031504R1		NSP
C1010	CHIP TYPE CERAMIC CAPACITOR	CK725B1H-104K1	1	332101045R1	N	NSP
C1012	CHIP ELECT C	CECS4V-220M	1	3986G2217R2	N	NSP
C1012or	CHIP ELECT C	CEWX4V-220M	(1)	3981G2217R2		NSP
C1013	CHIP TYPE CERAMIC CAPACITOR	CK725B1C-104K0	1	332011045R1		NSP
C1014	CHIP TYPE CERAMIC CAPACITOR	CK725B1C-104K0	1	332011045R1		NSP
C1016	CHIP TYPE CERAMIC CAPACITOR	CK725B1H-104K1	1	332101045R1	N	NSP
C1017	CHIP ELECT C	CECS16V-100M	1	398641017R2	N	NSP
C1017or	CHIP ELECT C	CEWX16V-100M	(1)	398141017R2		NSP
C1018	CHIP TYPE CERAMIC CAPACITOR	CK725B1C-104K0	1	332011045R1		NSP
C1019	CHIP TYPE CERAMIC CAPACITOR	CK732B16V-106K	1	332071065R2		NSP
C1020	CHIP ELECT C	CECS4V-220M	1	3986G2217R2	N	NSP
C1020or	CHIP ELECT C	CEWX4V-220M	(1)	3981G2217R2		NSP
C1021	CHIP TYPE CERAMIC CAPACITOR	CK725B1H-472K0	1	332034725R1		NSP
C1022	CHIP ELECT C	CE32W16V-47M(EC-PC)	1	3500238R2	N	NSP
C1023	CHIP ELECT C	CECS16V-100M	1	398641017R2	N	NSP
C1023or	CHIP ELECT C	CEWX16V-100M	(1)	398141017R2		NSP
C1024	CHIP TYPE CERAMIC CAPACITOR	CK732B16V-106K	1	332071065R2		NSP
C1025	CHIP TYPE CERAMIC CAPACITOR	CK725B1H-223K0	1	332032235R1		NSP
C1026	CHIP TYPE CERAMIC CAPACITOR	CK725B1E-473K0	1	332024735R1		NSP
C1027	CHIP ELECT C	CECS4V-220M	1	3986G2217R2	N	NSP
C1027or	CHIP ELECT C	CEWX4V-220M	(1)	3981G2217R2		NSP
C1030	CHIP TYPE CERAMIC CAPACITOR	CK732B16V-106K	1	332071065R2		NSP
C1032	CHIP TYPE CERAMIC CAPACITOR	CK725B1A-105K0	1	332001055R1		NSP
C1033	CHIP TYPE CERAMIC CAPACITOR	CK725B1A-105K0	1	332001055R1		NSP
C1038	CHIP TYPE CERAMIC CAPACITOR	CC725CH1H-331J0	1	342033314R1		NSP
C1051	CHIP TYPE CERAMIC CAPACITOR	CK725B1C-104K0	1	332011045R1		NSP
C1052	CHIP TYPE CERAMIC CAPACITOR	CK725B1C-104K0	1	332011045R1		NSP
C1053	CHIP TYPE CERAMIC CAPACITOR	CK725B1C-104K0	1	332011045R1		NSP
C1054	CHIP TYPE CERAMIC CAPACITOR	CK725B1A-225K1	1	332132255R1	N	NSP
C1055	CHIP TYPE CERAMIC CAPACITOR	CK725B1A-225K1	1	332132255R1	N	NSP
C1056	CHIP TYPE CERAMIC CAPACITOR	CK725B1C-104K0	1	332011045R1		NSP
C1057	CHIP TYPE CERAMIC CAPACITOR	CK732B16V-106K	1	332071065R2		NSP
C1058	CHIP TYPE CERAMIC CAPACITOR	CK725B1H-103K0	1	332031035R1		NSP
C1059	CHIP TYPE CERAMIC CAPACITOR	CK725B1H-103K0	1	332031035R1		NSP
C1068	CHIP TYPE CERAMIC CAPACITOR	CK725B1C-104K0	1	332011045R1		NSP
C1069	CHIP TYPE CERAMIC CAPACITOR	CK725B1C-104K0	1	332011045R1		NSP
C1073	CHIP TYPE CERAMIC CAPACITOR	CK725B1C-104K0	1	332011045R1		NSP
C1074	CHIP TYPE CERAMIC CAPACITOR	CK725B1C-104K0	1	332011045R1		NSP
C1075	CHIP TYPE CERAMIC CAPACITOR	CK725B1C-104K0	1	332011045R1		NSP
C1079	CHIP TYPE CERAMIC CAPACITOR	CK725B1C-104K0	1	332011045R1		NSP
C1091	CHIP TYPE CERAMIC CAPACITOR	CK725B0J-226M	1	332092267R2	N	NSP
C1092	CHIP TYPE CERAMIC CAPACITOR	CK732B16V-106K	1	332071065R2		NSP
C1093	CHIP TYPE CERAMIC CAPACITOR	CK732B16V-106K	1	332071065R2		NSP
C1094	CHIP TYPE CERAMIC CAPACITOR	CK732B16V-106K	1	332071065R2		NSP
C1095	CHIP TYPE CERAMIC CAPACITOR	CK725B1C-104K0	1	332011045R1		NSP
C1105	CHIP TYPE CERAMIC CAPACITOR	CK725B1C-104K0	1	332011045R1		NSP
C1106	CHIP TYPE CERAMIC CAPACITOR	CK725B1C-104K0	1	332011045R1		NSP
C1114	CHIP TYPE CERAMIC CAPACITOR	CK725B1H-103K0	1	332031035R1		NSP
C1119	CHIP TYPE CERAMIC CAPACITOR	CK725B1H-102K0	1	332031025R1		NSP

C3423	CHIP TYPE CERAMIC CAPACITOR	CK725B1C-104K0	1	332011045R1	NSP
C3424	CHIP TYPE CERAMIC CAPACITOR	CK725B1C-104K0	1	332011045R1	NSP
C3425	CHIP TYPE CERAMIC CAPACITOR	CK725B1C-104K0	1	332011045R1	NSP
C3426	CHIP TYPE CERAMIC CAPACITOR	CK725B1H-102K0	1	332031025R1	NSP
C3427	CHIP TYPE CERAMIC CAPACITOR	CK725B1C-104K0	1	332011045R1	NSP
C3428	CHIP TYPE CERAMIC CAPACITOR	CK725B1H-103K0	1	332031035R1	NSP
C3429	CHIP TYPE CERAMIC CAPACITOR	CK725B1H-103K0	1	332031035R1	NSP
C3431	CHIP TYPE CERAMIC CAPACITOR	CK725B1H-102K0	1	332031025R1	NSP
C3432	CHIP TYPE CERAMIC CAPACITOR	CK725B1H-102K0	1	332031025R1	NSP
C3433	CHIP TYPE CERAMIC CAPACITOR	CK725B1C-104K0	1	332011045R1	NSP
C3434	CHIP TYPE CERAMIC CAPACITOR	CK732B16V-106K	1	332071065R2	NSP
C3435	CHIP TYPE CERAMIC CAPACITOR	CK732B16V-106K	1	332071065R2	NSP
C3436	CHIP TYPE CERAMIC CAPACITOR	CK732B16V-106K	1	332071065R2	NSP
C3437	CHIP TYPE CERAMIC CAPACITOR	CK725B1C-104K0	1	332011045R1	NSP
C3438	CHIP TYPE CERAMIC CAPACITOR	CK725B1C-104K0	1	332011045R1	NSP
C3439	CHIP TYPE CERAMIC CAPACITOR	CK725B1C-104K0	1	332011045R1	NSP
C3440	CHIP TYPE CERAMIC CAPACITOR	CK725B1C-104K0	1	332011045R1	NSP
C3441	CHIP TYPE CERAMIC CAPACITOR	CK725B1C-104K0	1	332011045R1	NSP
C3442	CHIP TYPE CERAMIC CAPACITOR	CK732B16V-106K	1	332071065R2	NSP
C3443	CHIP TYPE CERAMIC CAPACITOR	CK725B1A-105K0	1	332001055R1	NSP
C3444	CHIP TYPE CERAMIC CAPACITOR	CK725B1A-105K0	1	332001055R1	NSP
C3445	CHIP TYPE CERAMIC CAPACITOR	CK725B1A-105K0	1	332001055R1	NSP
C3446	CHIP TYPE CERAMIC CAPACITOR	CK725B1A-105K0	1	332001055R1	NSP
C3457	CHIP TYPE CERAMIC CAPACITOR	CK725B1C-104K0	1	332011045R1	NSP
C3458	CHIP TYPE CERAMIC CAPACITOR	CK725B1C-104K0	1	332011045R1	NSP
C3459	CHIP TYPE CERAMIC CAPACITOR	CK725B1C-104K0	1	332011045R1	NSP
C3462	CHIP TYPE CERAMIC CAPACITOR	CK732B16V-106K	1	332071065R2	NSP
C3601	CHIP TYPE CERAMIC CAPACITOR	CK725B0J-226M	1	332092267R2	N NSP
C3602	CHIP TYPE CERAMIC CAPACITOR	CK725B0J-226M	1	332092267R2	N NSP
C3603	CHIP TYPE CERAMIC CAPACITOR	CK725B1H-102K0	1	332031025R1	NSP
C3651	CHIP TYPE CERAMIC CAPACITOR	CK725B1A-105K0	1	332001055R1	NSP
C3652	CHIP TYPE CERAMIC CAPACITOR	CK725B0J-226M	1	332092267R2	N NSP
C3654	CHIP TYPE CERAMIC CAPACITOR	CK725B1C-104K0	1	332011045R1	NSP
C3655	CHIP TYPE CERAMIC CAPACITOR	CK725B1C-104K0	1	332011045R1	NSP
C3656	CHIP TYPE CERAMIC CAPACITOR	CK725B1C-104K0	1	332011045R1	NSP
C3657	CHIP TYPE CERAMIC CAPACITOR	CK725B1C-104K0	1	332011045R1	NSP
C3659	CHIP TYPE CERAMIC CAPACITOR	CK725B1C-104K0	1	332011045R1	NSP
C3660	CHIP TYPE CERAMIC CAPACITOR	CK725B1H-102K0	1	332031025R1	NSP
C3661	CHIP TYPE CERAMIC CAPACITOR	CK725B1H-102K0	1	332031025R1	NSP
C3662	CHIP TYPE CERAMIC CAPACITOR	CK725B0J-226M	1	332092267R2	N NSP
C3663	CHIP TYPE CERAMIC CAPACITOR	CK725B1A-225K1	1	332132255R1	N NSP
C3664	CHIP TYPE CERAMIC CAPACITOR	CK725B0J-226M	1	332092267R2	N NSP
C3665	CHIP TYPE CERAMIC CAPACITOR	CK725B0J-226M	1	332092267R2	N NSP
C3666	CHIP TYPE CERAMIC CAPACITOR	CC725CH1H-150J0	1	342031504R1	NSP
C3667	CHIP TYPE CERAMIC CAPACITOR	CC725CH1H-150J0	1	342031504R1	NSP
C3668	CHIP TYPE CERAMIC CAPACITOR	CK725B1C-104K0	1	332011045R1	NSP
C3669	CHIP TYPE CERAMIC CAPACITOR	CK725B1C-104K0	1	332011045R1	NSP
C3670	CHIP TYPE CERAMIC CAPACITOR	CK725B1C-104K0	1	332011045R1	NSP
C3674	CHIP TYPE CERAMIC CAPACITOR	CK725B1H-103K0	1	332031035R1	NSP
C3685	CHIP TYPE CERAMIC CAPACITOR	CK732B16V-106K	1	332071065R2	NSP
C3686	CHIP TYPE CERAMIC CAPACITOR	CK725B1A-105K0	1	332001055R1	NSP
C3689	CHIP TYPE CERAMIC CAPACITOR	CK725B1H-223K0	1	332032235R1	NSP
C3690	CHIP TYPE CERAMIC CAPACITOR	CC725CH1H-221J0	1	342032214R1	NSP
C3691	CHIP TYPE CERAMIC CAPACITOR	CC725CH1H-220J0	1	342032204R1	NSP
C3800	CHIP TYPE CERAMIC CAPACITOR	CK725B1H-103K0	1	332031035R1	NSP

C7003	CHIP TYPE CERAMIC CAPACITOR	CK725B1C-104K0	1	332011045R1	NSP
C7004	CHIP TYPE CERAMIC CAPACITOR	CK725B1C-104K0	1	332011045R1	NSP
C7008	CHIP TYPE CERAMIC CAPACITOR	CK725B50V-224K	1	332242245R1	N NSP
C7009	CHIP TYPE CERAMIC CAPACITOR	CK725B1A-105K0	1	332001055R1	NSP
C7010	CHIP TYPE CERAMIC CAPACITOR	CK725B50V-224K	1	332242245R1	N NSP
C7011	CHIP TYPE CERAMIC CAPACITOR	CK725B1A-105K0	1	332001055R1	NSP
C7012	CHIP TYPE CERAMIC CAPACITOR	CK725B50V-224K	1	332242245R1	N NSP
C7013	CHIP TYPE CERAMIC CAPACITOR	CK725B1A-105K0	1	332001055R1	NSP
C7014	CHIP TYPE CERAMIC CAPACITOR	CK725B1C-104K0	1	332011045R1	NSP
C7015	CHIP TYPE CERAMIC CAPACITOR	CK725B1C-104K0	1	332011045R1	NSP
C7017	CHIP TYPE CERAMIC CAPACITOR	CK725B1C-104K0	1	332011045R1	NSP
C7018	CHIP TYPE CERAMIC CAPACITOR	CK725B1C-104K0	1	332011045R1	NSP
C7019	CHIP TYPE CERAMIC CAPACITOR	CK725B1C-104K0	1	332011045R1	NSP
C7020	CHIP TYPE CERAMIC CAPACITOR	CK725B1A-475K1	1	332134755R1	N NSP
C7029	CHIP TYPE CERAMIC CAPACITOR	CK732B16V-106K	1	332071065R2	NSP
C7030	CHIP TYPE CERAMIC CAPACITOR	CK725B1H-102K0	1	332031025R1	NSP
C7031	CHIP TYPE CERAMIC CAPACITOR	CK725B1H-102K0	1	332031025R1	NSP
C7032	CHIP TYPE CERAMIC CAPACITOR	CK725B1C-104K0	1	332011045R1	NSP
C7036	CHIP TYPE CERAMIC CAPACITOR	CK725B1C-104K0	1	332011045R1	NSP
C7038	CHIP TYPE CERAMIC CAPACITOR	CK732B16V-106K	1	332071065R2	NSP
C7039	CHIP TYPE CERAMIC CAPACITOR	CK732B16V-106K	1	332071065R2	NSP
C7052	CHIP TYPE CERAMIC CAPACITOR	CK725B1H-102K0	1	332031025R1	NSP
C7062	CHIP TYPE CERAMIC CAPACITOR	CK732B16V-106K	1	332071065R2	NSP
C7075	CHIP TYPE CERAMIC CAPACITOR	CK725B1E-153K0	1	332021535R1	NSP
C7076	CHIP TYPE CERAMIC CAPACITOR	CK725B1H-104K1	1	332101045R1	N NSP
C7077	CHIP TYPE CERAMIC CAPACITOR	CC725CH1H-101J0	1	342031014R1	NSP
C7180	CHIP TYPE CERAMIC CAPACITOR	CK725B1H-102K0	1	332031025R1	NSP
C7181	CHIP TYPE CERAMIC CAPACITOR	CK725B1H-102K0	1	332031025R1	NSP
C7182	CHIP TYPE CERAMIC CAPACITOR	CK725B1H-102K0	1	332031025R1	NSP
C7183	CHIP TYPE CERAMIC CAPACITOR	CK725B1H-102K0	1	332031025R1	NSP
C7184	CHIP TYPE CERAMIC CAPACITOR	CK725B1A-105K0	1	332001055R1	NSP
C8007	CHIP TYPE CERAMIC CAPACITOR	CK725B1H-102K0	1	332031025R1	NSP
C8008	CHIP TYPE CERAMIC CAPACITOR	CK725B1H-102K0	1	332031025R1	NSP
C8024	CHIP TYPE CERAMIC CAPACITOR	CK725B1A-105K0	1	332001055R1	NSP
C8038	CHIP TYPE CERAMIC CAPACITOR	CK725B1C-104K0	1	332011045R1	NSP
C8091	CHIP TYPE CERAMIC CAPACITOR	CK725B1C-104K0	1	332011045R1	NSP
C8113	CHIP TYPE CERAMIC CAPACITOR	CK725B1C-104K0	1	332011045R1	NSP
C8206	CHIP TYPE CERAMIC CAPACITOR	CK725B1C-104K0	1	332011045R1	NSP
C8207	CHIP TYPE CERAMIC CAPACITOR	CK725B1H-102K0	1	332031025R1	NSP
C8208	CHIP TYPE CERAMIC CAPACITOR	CK725B1C-104K0	1	332011045R1	NSP
C8210	CHIP TYPE CERAMIC CAPACITOR	CK725B1C-104K0	1	332011045R1	NSP
C8211	CHIP TYPE CERAMIC CAPACITOR	CK725B1C-104K0	1	332011045R1	NSP
C8214	CHIP TYPE CERAMIC CAPACITOR	CK725B1C-104K0	1	332011045R1	NSP
C8215	CHIP TYPE CERAMIC CAPACITOR	CK732B16V-106K	1	332071065R2	NSP
C8219	CHIP TYPE CERAMIC CAPACITOR	CK725B1H-103K0	1	332031035R1	NSP
C8220	CHIP TYPE CERAMIC CAPACITOR	CK725B1C-104K0	1	332011045R1	NSP
C8221	CHIP TYPE CERAMIC CAPACITOR	CK725B1H-102K0	1	332031025R1	NSP
C8222	CHIP TYPE CERAMIC CAPACITOR	CK725B1C-104K0	1	332011045R1	NSP
C8223	CHIP TYPE CERAMIC CAPACITOR	CK725B1C-104K0	1	332011045R1	NSP
C8224	CHIP TYPE CERAMIC CAPACITOR	CK725B1C-104K0	1	332011045R1	NSP
C8225	CHIP TYPE CERAMIC CAPACITOR	CK725B1C-104K0	1	332011045R1	NSP
C8229	CHIP TYPE CERAMIC CAPACITOR	CK725B1H-102K0	1	332031025R1	NSP
C8230	CHIP TYPE CERAMIC CAPACITOR	CK725B1C-104K0	1	332011045R1	NSP
C8231	CHIP TYPE CERAMIC CAPACITOR	CK725B1C-104K0	1	332011045R1	NSP
C8232	CHIP TYPE CERAMIC CAPACITOR	CK725B1H-103K0	1	332031035R1	NSP

C8236	CHIP TYPE CERAMIC CAPACITOR	CC725CH1H-150J0	1	342031504R1	NSP
C8237	CHIP TYPE CERAMIC CAPACITOR	CC725CH1H-120J0	1	342031204R1	NSP
C8239	CHIP TYPE CERAMIC CAPACITOR	CK725B1H-103K0	1	332031035R1	NSP
C8240	CHIP TYPE CERAMIC CAPACITOR	CK725B1C-683K0	1	332016835R1	NSP
C8241	CHIP TYPE CERAMIC CAPACITOR	CK725B1E-153K0	1	332021535R1	NSP
C8255	CHIP TYPE CERAMIC CAPACITOR	CK732B16V-106K	1	332071065R2	NSP
C8257	CHIP TYPE CERAMIC CAPACITOR	CK732B16V-106K	1	332071065R2	NSP
C8260	CHIP TYPE CERAMIC CAPACITOR	CK732B16V-106K	1	332071065R2	NSP
C8261	CHIP TYPE CERAMIC CAPACITOR	CK732B16V-106K	1	332071065R2	NSP
C8301	CHIP TYPE CERAMIC CAPACITOR	CK732B16V-106K	1	332071065R2	NSP
C8303	CHIP TYPE CERAMIC CAPACITOR	CK725B0J-226M	1	332092267R2	N NSP
C8305	CHIP TYPE CERAMIC CAPACITOR	CK725B1H-102K0	1	332031025R1	NSP
C8306	CHIP TYPE CERAMIC CAPACITOR	CK725B1C-104K0	1	332011045R1	NSP
C8307	CHIP TYPE CERAMIC CAPACITOR	CK725B1H-102K0	1	332031025R1	NSP
C8308	CHIP TYPE CERAMIC CAPACITOR	CK725B1C-104K0	1	332011045R1	NSP
C8309	CHIP TYPE CERAMIC CAPACITOR	CK725B1H-102K0	1	332031025R1	NSP
C8310	CHIP TYPE CERAMIC CAPACITOR	CK725B1C-104K0	1	332011045R1	NSP
C8311	CHIP TYPE CERAMIC CAPACITOR	CK725B1H-102K0	1	332031025R1	NSP
C8312	CHIP TYPE CERAMIC CAPACITOR	CK725B1C-104K0	1	332011045R1	NSP
C8313	CHIP TYPE CERAMIC CAPACITOR	CK725B1H-102K0	1	332031025R1	NSP
C8314	CHIP TYPE CERAMIC CAPACITOR	CK725B1C-104K0	1	332011045R1	NSP
C8315	CHIP TYPE CERAMIC CAPACITOR	CK725B1H-102K0	1	332031025R1	NSP
C8316	CHIP TYPE CERAMIC CAPACITOR	CK725B1C-104K0	1	332011045R1	NSP
C8317	CHIP TYPE CERAMIC CAPACITOR	CK725B1H-102K0	1	332031025R1	NSP
C8318	CHIP TYPE CERAMIC CAPACITOR	CK725B1C-104K0	1	332011045R1	NSP
C8319	CHIP TYPE CERAMIC CAPACITOR	CK725B1C-104K0	1	332011045R1	NSP
C8320	CHIP TYPE CERAMIC CAPACITOR	CK725B1H-102K0	1	332031025R1	NSP
C8321	CHIP TYPE CERAMIC CAPACITOR	CC725CH1H-090D0	1	342030902R1	NSP
C8322	CHIP TYPE CERAMIC CAPACITOR	CK725B1H-102K0	1	332031025R1	NSP
C8323	CHIP TYPE CERAMIC CAPACITOR	CK725B1C-104K0	1	332011045R1	NSP
C8324	CHIP TYPE CERAMIC CAPACITOR	CK725B1C-104K0	1	332011045R1	NSP
C8325	CHIP TYPE CERAMIC CAPACITOR	CC725CH1H-090D0	1	342030902R1	NSP
C8326	CHIP TYPE CERAMIC CAPACITOR	CK725B1H-102K0	1	332031025R1	NSP
C8327	CHIP TYPE CERAMIC CAPACITOR	CK725B1H-102K0	1	332031025R1	NSP
C8328	CHIP TYPE CERAMIC CAPACITOR	CK725B1C-104K0	1	332011045R1	NSP
C8329	CHIP TYPE CERAMIC CAPACITOR	CK725B1H-102K0	1	332031025R1	NSP
C8330	CHIP TYPE CERAMIC CAPACITOR	CK725B1C-104K0	1	332011045R1	NSP
C8331	CHIP TYPE CERAMIC CAPACITOR	CK725B1C-104K0	1	332011045R1	NSP
C8332	CHIP TYPE CERAMIC CAPACITOR	CK725B1A-105K0	1	332001055R1	NSP
C8333	CHIP TYPE CERAMIC CAPACITOR	CK725B1H-102K0	1	332031025R1	NSP
C8334	CHIP TYPE CERAMIC CAPACITOR	CK725B1C-104K0	1	332011045R1	NSP
C8335	CHIP TYPE CERAMIC CAPACITOR	CK725B1H-102K0	1	332031025R1	NSP
C8336	CHIP TYPE CERAMIC CAPACITOR	CK725B1C-104K0	1	332011045R1	NSP
C8338	CHIP TYPE CERAMIC CAPACITOR	CK725B1H-102K0	1	332031025R1	NSP
C8340	CHIP TYPE CERAMIC CAPACITOR	CK725B1C-104K0	1	332011045R1	NSP
C8341	CHIP TYPE CERAMIC CAPACITOR	CK725B1H-102K0	1	332031025R1	NSP
C8342	CHIP TYPE CERAMIC CAPACITOR	CK725B1C-104K0	1	332011045R1	NSP
C8343	CHIP TYPE CERAMIC CAPACITOR	CK725B1H-102K0	1	332031025R1	NSP
C8344	CHIP TYPE CERAMIC CAPACITOR	CK725B1C-104K0	1	332011045R1	NSP
C8345	CHIP TYPE CERAMIC CAPACITOR	CK725B1H-102K0	1	332031025R1	NSP
C8349	CHIP TYPE CERAMIC CAPACITOR	CK725B1A-105K0	1	332001055R1	NSP
C8353	CHIP TYPE CERAMIC CAPACITOR	CK725B1C-104K0	1	332011045R1	NSP
C8354	CHIP TYPE CERAMIC CAPACITOR	CK725B1A-105K0	1	332001055R1	NSP
C8356	CHIP TYPE CERAMIC CAPACITOR	CK732B16V-106K	1	332071065R2	NSP
C8357	CHIP TYPE CERAMIC CAPACITOR	CK732B16V-106K	1	332071065R2	NSP

C8443	CHIP TYPE CERAMIC CAPACITOR	CK732B16V-106K	1	332071065R2	NSP
C8444	CHIP TYPE CERAMIC CAPACITOR	CK732B16V-106K	1	332071065R2	NSP
C8445	CHIP TYPE CERAMIC CAPACITOR	CK732B16V-106K	1	332071065R2	NSP
C8446	CHIP TYPE CERAMIC CAPACITOR	CK732B16V-106K	1	332071065R2	NSP
C8447	CHIP TYPE CERAMIC CAPACITOR	CK732B16V-106K	1	332071065R2	NSP
C8449	CHIP TYPE CERAMIC CAPACITOR	CK725B1C-104K0	1	332011045R1	NSP
C8450	CHIP TYPE CERAMIC CAPACITOR	CK725B1C-104K0	1	332011045R1	NSP
C8451	CHIP TYPE CERAMIC CAPACITOR	CK725B1C-104K0	1	332011045R1	NSP
C8452	CHIP TYPE CERAMIC CAPACITOR	CK725B1C-104K0	1	332011045R1	NSP
C8453	CHIP TYPE CERAMIC CAPACITOR	CK725B1C-104K0	1	332011045R1	NSP
C8454	CHIP TYPE CERAMIC CAPACITOR	CK725B1C-104K0	1	332011045R1	NSP
C8455	CHIP TYPE CERAMIC CAPACITOR	CK725B1C-104K0	1	332011045R1	NSP
C8456	CHIP TYPE CERAMIC CAPACITOR	CK725B1C-104K0	1	332011045R1	NSP
C8457	CHIP TYPE CERAMIC CAPACITOR	CK725B1C-104K0	1	332011045R1	NSP
C8460	CHIP TYPE CERAMIC CAPACITOR	CC725CH1H-120J0	1	342031204R1	NSP
C8461	CHIP TYPE CERAMIC CAPACITOR	CC725CH1H-120J0	1	342031204R1	NSP
C8463	CHIP TYPE CERAMIC CAPACITOR	CC725CH1H-101J0	1	342031014R1	NSP
C8470	CHIP TYPE CERAMIC CAPACITOR	CK732B16V-106K	1	332071065R2	NSP
C8472	CHIP TYPE CERAMIC CAPACITOR	CK725B1C-104K0	1	332011045R1	NSP
C8473	CHIP TYPE CERAMIC CAPACITOR	CK725B1C-104K0	1	332011045R1	NSP
C8474	CHIP TYPE CERAMIC CAPACITOR	CK725B1H-102K0	1	332031025R1	NSP
C8475	CHIP TYPE CERAMIC CAPACITOR	CK725B1H-102K0	1	332031025R1	NSP
C8476	CHIP TYPE CERAMIC CAPACITOR	CK725B1A-105K0	1	332001055R1	NSP
C8477	CHIP TYPE CERAMIC CAPACITOR	CK725B1A-105K0	1	332001055R1	NSP
C8478	CHIP TYPE CERAMIC CAPACITOR	CK725B1A-105K0	1	332001055R1	NSP
C8484	CHIP TYPE CERAMIC CAPACITOR	CK725B1H-102K0	1	332031025R1	NSP
C8485	CHIP TYPE CERAMIC CAPACITOR	CK725B1C-104K0	1	332011045R1	NSP
C8611	CHIP TYPE CERAMIC CAPACITOR	CK725B1H-102K0	1	332031025R1	NSP
C8612	CHIP TYPE CERAMIC CAPACITOR	CK725B1H-102K0	1	332031025R1	NSP
C8621	CHIP TYPE CERAMIC CAPACITOR	CK725B1H-102K0	1	332031025R1	NSP
C8631	CHIP TYPE CERAMIC CAPACITOR	CK725B1H-102K0	1	332031025R1	NSP
C8632	CHIP TYPE CERAMIC CAPACITOR	CK725B1H-102K0	1	332031025R1	NSP
C8661	CHIP TYPE CERAMIC CAPACITOR	CK725B1H-102K0	1	332031025R1	NSP
C8662	CHIP TYPE CERAMIC CAPACITOR	CK725B1H-102K0	1	332031025R1	NSP
C8700	CHIP TYPE CERAMIC CAPACITOR	CK725B1C-104K0	1	332011045R1	NSP
C8701	CHIP TYPE CERAMIC CAPACITOR	CK725B1C-104K0	1	332011045R1	NSP
C8702	CHIP TYPE CERAMIC CAPACITOR	CK725B1C-104K0	1	332011045R1	NSP
C8703	CHIP TYPE CERAMIC CAPACITOR	CK725B1C-104K0	1	332011045R1	NSP
C8704	CHIP TYPE CERAMIC CAPACITOR	CK725B1C-104K0	1	332011045R1	NSP
C8705	CHIP TYPE CERAMIC CAPACITOR	CK725B1A-105K0	1	332001055R1	NSP
C8706	CHIP TYPE CERAMIC CAPACITOR	CK725B1C-104K0	1	332011045R1	NSP
C8707	CHIP TYPE CERAMIC CAPACITOR	CK725B1C-104K0	1	332011045R1	NSP
C8709	CHIP TYPE CERAMIC CAPACITOR	CK732B16V-106K	1	332071065R2	NSP
C8710	CHIP TYPE CERAMIC CAPACITOR	CK725B1C-104K0	1	332011045R1	NSP
C8894	CHIP TYPE CERAMIC CAPACITOR	CK725B0J-226M	1	332092267R2	N NSP
C8895	CHIP TYPE CERAMIC CAPACITOR	CK725B1C-104K0	1	332011045R1	NSP
C8907	CHIP TYPE CERAMIC CAPACITOR	CK725B1A-105K0	1	332001055R1	NSP
C8908	CHIP TYPE CERAMIC CAPACITOR	CK732B16V-106K	1	332071065R2	NSP
C8909	CHIP TYPE CERAMIC CAPACITOR	CK725B1A-105K0	1	332001055R1	NSP
C8910	CHIP TYPE CERAMIC CAPACITOR	CK725B0J-226M	1	332092267R2	N NSP
C8911	CHIP TYPE CERAMIC CAPACITOR	CK732B16V-106K	1	332071065R2	NSP
C8912	CHIP TYPE CERAMIC CAPACITOR	CK725B0J-226M	1	332092267R2	N NSP
C8913	CHIP TYPE CERAMIC CAPACITOR	CK725B1A-225K1	1	332132255R1	N NSP
C8917	CHIP TYPE CERAMIC CAPACITOR	CK725B1C-104K0	1	332011045R1	NSP
C8918	CHIP TYPE CERAMIC CAPACITOR	CK725B0J-226M	1	332092267R2	N NSP

C8921	CHIP TYPE CERAMIC CAPACITOR	CK725B1H-103K0	1	332031035R1	NSP
C8922	CHIP TYPE CERAMIC CAPACITOR	CK725B1C-104K0	1	332011045R1	NSP
C8923	CHIP TYPE CERAMIC CAPACITOR	CK725B1E-106K	1	332221065R2	NSP
C8924	CHIP TYPE CERAMIC CAPACITOR	CK725B1E-106K	1	332221065R2	NSP
C8925	CHIP TYPE CERAMIC CAPACITOR	CK725B1H-103K0	1	332031035R1	NSP
C8926	CHIP TYPE CERAMIC CAPACITOR	CK725B0J-226M	1	332092267R2	N NSP
C8927	CHIP TYPE CERAMIC CAPACITOR	CK725B0J-226M	1	332092267R2	N NSP
C8929	CHIP TYPE CERAMIC CAPACITOR	CK732B16V-106K	1	332071065R2	NSP
C8930	CHIP TYPE CERAMIC CAPACITOR	CK725B0J-226M	1	332092267R2	N NSP
C8931	CHIP TYPE CERAMIC CAPACITOR	CK725B1H-103K0	1	332031035R1	NSP
C8932	CHIP TYPE CERAMIC CAPACITOR	CK725B1C-104K0	1	332011045R1	NSP
C8933	CHIP TYPE CERAMIC CAPACITOR	CK725B1E-106K	1	332221065R2	NSP
C8934	CHIP TYPE CERAMIC CAPACITOR	CK725B1E-106K	1	332221065R2	NSP
C8935	CHIP TYPE CERAMIC CAPACITOR	CK725B1H-103K0	1	332031035R1	NSP
C8936	CHIP TYPE CERAMIC CAPACITOR	CK725B0J-226M	1	332092267R2	N NSP
C8937	CHIP TYPE CERAMIC CAPACITOR	CK725B0J-226M	1	332092267R2	N NSP
C8941	CHIP TYPE CERAMIC CAPACITOR	CK725B1H-103K0	1	332031035R1	NSP
C8942	CHIP TYPE CERAMIC CAPACITOR	CK725B1C-104K0	1	332011045R1	NSP
C8943	CHIP TYPE CERAMIC CAPACITOR	CK725B1E-106K	1	332221065R2	NSP
C8944	CHIP TYPE CERAMIC CAPACITOR	CK725B1E-106K	1	332221065R2	NSP
C8945	CHIP TYPE CERAMIC CAPACITOR	CK725B1H-103K0	1	332031035R1	NSP
C8946	CHIP TYPE CERAMIC CAPACITOR	CK725B0J-226M	1	332092267R2	N NSP
C8947	CHIP TYPE CERAMIC CAPACITOR	CK725B0J-226M	1	332092267R2	N NSP
C8951	CHIP TYPE CERAMIC CAPACITOR	CK725B1H-103K0	1	332031035R1	NSP
C8952	CHIP TYPE CERAMIC CAPACITOR	CK725B1C-104K0	1	332011045R1	NSP
C8953	CHIP TYPE CERAMIC CAPACITOR	CK725B1E-106K	1	332221065R2	NSP
C8954	CHIP TYPE CERAMIC CAPACITOR	CK725B1E-106K	1	332221065R2	NSP
C8955	CHIP TYPE CERAMIC CAPACITOR	CK725B1H-103K0	1	332031035R1	NSP
C8956	CHIP TYPE CERAMIC CAPACITOR	CK725B0J-226M	1	332092267R2	N NSP
C8957	CHIP TYPE CERAMIC CAPACITOR	CK725B0J-226M	1	332092267R2	N NSP
C8961	CHIP TYPE CERAMIC CAPACITOR	CK725B1H-103K0	1	332031035R1	NSP
C8962	CHIP TYPE CERAMIC CAPACITOR	CK725B1C-104K0	1	332011045R1	NSP
C8963	CHIP TYPE CERAMIC CAPACITOR	CK725B1E-106K	1	332221065R2	NSP
C8964	CHIP TYPE CERAMIC CAPACITOR	CK725B1E-106K	1	332221065R2	NSP
C8966	CHIP TYPE CERAMIC CAPACITOR	CK725B0J-226M	1	332092267R2	N NSP
C8967	CHIP TYPE CERAMIC CAPACITOR	CK725B0J-226M	1	332092267R2	N NSP
C8980	CHIP TYPE CERAMIC CAPACITOR	CK725B1A-105K0	1	332001055R1	NSP
C8981	CHIP TYPE CERAMIC CAPACITOR	CK732B16V-106K	1	332071065R2	NSP
C8985	CHIP TYPE CERAMIC CAPACITOR	CK725B0J-226M	1	332092267R2	N NSP
C8986	CHIP TYPE CERAMIC CAPACITOR	CK725B0J-226M	1	332092267R2	N NSP
C8987	CHIP TYPE CERAMIC CAPACITOR	CK725B0J-226M	1	332092267R2	N NSP

[Resistors]

R1001	CHIP TYPE CARBON RESISTOR	RN72K1J-331JE	1	435033314R1	NSP
R1002	CHIP TYPE CARBON RESISTOR	RN72K1J-151JE	1	435031514R1	NSP
R1003	CHIP TYPE CARBON RESISTOR	RN72K1J-151JE	1	435031514R1	NSP
R1004	CHIP TYPE CARBON RESISTOR	RN72K1J-151JE	1	435031514R1	NSP
R1005	CHIP TYPE CARBON RESISTOR	RN72K1J-331JE	1	435033314R1	NSP
R1006	CHIP TYPE CARBON RESISTOR	RN72K1J-560JE	1	435035604R1	NSP
R1007	CHIP TYPE CARBON RESISTOR	RN72K1J-105JE	1	435031054R1	NSP
R1008	CHIP TYPE CARBON RESISTOR	RN72K1J-102JE	1	435031024R1	NSP
R1010	CHIP TYPE CARBON RESISTOR	RN72K1J-103JE	1	435031034R1	NSP
R1011	CHIP TYPE CARBON RESISTOR	RN72K1J-220JE	1	435032204R1	NSP
R1012	CHIP TYPE CARBON RESISTOR	RN72K1J-220JE	1	435032204R1	NSP
R1013	CHIP TYPE CARBON RESISTOR	RN72K1J-220JE	1	435032204R1	NSP
R1014	CHIP TYPE CARBON RESISTOR	RN72K1J-220JE	1	435032204R1	NSP

R1015	CHIP TYPE CARBON RESISTOR	RN72K1J-220JE	1	435032204R1	NSP
R1016	CHIP TYPE CARBON RESISTOR	RN72K1J-220JE	1	435032204R1	NSP
R1017	CHIP TYPE CARBON RESISTOR	RN72K1J-470JE	1	435034704R1	NSP
R1019	CHIP TYPE CARBON RESISTOR	RN72K1J-470JE	1	435034704R1	NSP
R1020	CHIP TYPE CARBON RESISTOR	RN72K1J-391JE	1	435033914R1	NSP
R1021	CHIP TYPE CARBON RESISTOR	RN72K1J-101JE	1	435031014R1	NSP
R1022	CHIP TYPE CARBON RESISTOR	RN72K1J-151JE	1	435031514R1	NSP
R1023	CHIP TYPE CARBON RESISTOR	RN72K1J-221JE	1	435032214R1	NSP
R1024	CHIP TYPE CARBON RESISTOR	RN72K1J-470JE	1	435034704R1	NSP
R1025	CHIP TYPE CARBON RESISTOR	RN72K1J-470JE	1	435034704R1	NSP
R1026	CHIP TYPE CARBON RESISTOR	RN72K1J-331JE	1	435033314R1	NSP
R1027	CHIP TYPE CARBON RESISTOR	RN72K1J-221JE	1	435032214R1	NSP
R1028	CHIP TYPE CARBON RESISTOR	RN72K1J-221JE	1	435032214R1	NSP
R1029	CHIP TYPE CARBON RESISTOR	RN72K1J-102JE	1	435031024R1	NSP
R1031	CHIP TYPE CARBON RESISTOR	RN72K1J-331JE	1	435033314R1	NSP
R1032	CHIP TYPE CARBON RESISTOR	RN72K1J-331JE	1	435033314R1	NSP
R1034	CHIP TYPE CARBON RESISTOR	RN72K1J-221JE	1	435032214R1	NSP
R1035	CHIP TYPE CARBON RESISTOR	RN72K1J-331JE	1	435033314R1	NSP
R1037	CHIP TYPE CARBON RESISTOR	RN72K1J-331JE	1	435033314R1	NSP
R1039	CHIP TYPE CARBON RESISTOR	RN72K1J-330JE	1	435033304R1	NSP
R1041	CHIP TYPE CARBON RESISTOR	RN72K1J-221JE	1	435032214R1	NSP
R1042	CHIP TYPE CARBON RESISTOR	RN72K1J-331JE	1	435033314R1	NSP
R1043	CHIP TYPE CARBON RESISTOR	RN72K1J-221JE	1	435032214R1	NSP
R1044	CHIP TYPE CARBON RESISTOR	RN72K1J-221JE	1	435032214R1	NSP
R1046	CHIP TYPE CARBON RESISTOR	RN72K1J-470JE	1	435034704R1	NSP
R1047	CHIP TYPE CARBON RESISTOR	RN72K1J-681JE	1	435036814R1	NSP
R1049	CHIP RESISTOR NETWORK	MNR04MRAPJ103	1	43464710304R2	N NSP
R1049or	CHIP RESISTOR NETWORK	YCN104-103-JK	(1)	43464C10304R1	NSP
R1054	CHIP TYPE CARBON RESISTOR	RN72K1J-221JE	1	435032214R1	NSP
R1055	CHIP TYPE CARBON RESISTOR	RN72K1J-000JE	1	435030004R1	NSP
R1056	CHIP TYPE CARBON RESISTOR	RN72K1J-000JE	1	435030004R1	NSP
R1057	CHIP TYPE CARBON RESISTOR	RN72K1J-681JE	1	435036814R1	NSP
R1060	CHIP TYPE CARBON RESISTOR	RN72K1J-470JE	1	435034704R1	NSP
R1061	CHIP TYPE CARBON RESISTOR	RN72K1J-103JE	1	435031034R1	NSP
R1062	CHIP TYPE CARBON RESISTOR	RN72K1J-221JE	1	435032214R1	NSP
R1063	CHIP TYPE CARBON RESISTOR	RN72K1J-103JE	1	435031034R1	NSP
R1064	CHIP TYPE CARBON RESISTOR	RN72K1J-221JE	1	435032214R1	NSP
R1076	CHIP TYPE CARBON RESISTOR	RN72K1J-330JE	1	435033304R1	NSP
R1077	CHIP TYPE CARBON RESISTOR	RN72K1J-330JE	1	435033304R1	NSP
R1078	CHIP TYPE PLASTIC FILM CAPACITOR	50MU103KY11608	1	376921035R2	N NSP
R1079	CHIP TYPE PLASTIC FILM CAPACITOR	50MU103KY11608	1	376921035R2	N NSP
R1081	CHIP TYPE CARBON RESISTOR	RN72K1J-181JE	1	435031814R1	NSP
R1083	CHIP TYPE CARBON RESISTOR	RN72K1J-103JE	1	435031034R1	NSP
R1085	CHIP TYPE CARBON RESISTOR	RN72K1J-181JE	1	435031814R1	NSP
R1087	CHIP TYPE CARBON RESISTOR	RN72K1J-471JE	1	435034714R1	NSP
R1088	CHIP TYPE CARBON RESISTOR	RN72K1J-471JE	1	435034714R1	NSP
R1093	CHIP TYPE CARBON RESISTOR	RN72K1J-103JE	1	435031034R1	NSP
R1115	CHIP TYPE CARBON RESISTOR	RN72K1J-221JE	1	435032214R1	NSP
R1117	CHIP TYPE CARBON RESISTOR	RN72K1J-103JE	1	435031034R1	NSP
R1118	CHIP TYPE CARBON RESISTOR	RN72K1J-000JE	1	435030004R1	NSP
R1119	CHIP TYPE CARBON RESISTOR	RN72K1J-000JE	1	435030004R1	NSP
R1120	CHIP TYPE CARBON RESISTOR	RN72K1J-000JE	1	435030004R1	NSP
R1121	CHIP TYPE CARBON RESISTOR	RN72K1J-000JE	1	435030004R1	NSP
R1122	CHIP TYPE CARBON RESISTOR	RN72K1J-000JE	1	435030004R1	NSP
R1123	CHIP TYPE CARBON RESISTOR	RN72K1J-000JE	1	435030004R1	NSP

R1133	CHIP TYPE CARBON RESISTOR	RN72K1J-470JE	1	435034704R1	NSP
R1134	CHIP TYPE CARBON RESISTOR	RN72K1J-470JE	1	435034704R1	NSP
R1135	CHIP TYPE CARBON RESISTOR	RN72K1J-470JE	1	435034704R1	NSP
R1136	CHIP TYPE CARBON RESISTOR	RN72K1J-470JE	1	435034704R1	NSP
R1137	CHIP TYPE CARBON RESISTOR	RN72K1J-470JE	1	435034704R1	NSP
R1138	CHIP TYPE CARBON RESISTOR	RN72K1J-470JE	1	435034704R1	NSP
R1139	CHIP TYPE CARBON RESISTOR	RN72K1J-470JE	1	435034704R1	NSP
R1141	CHIP TYPE CARBON RESISTOR	RN72K1J-470JE	1	435034704R1	NSP
R1142	CHIP TYPE CARBON RESISTOR	RN72K1J-470JE	1	435034704R1	NSP
R1143	CHIP TYPE CARBON RESISTOR	RN72K1J-470JE	1	435034704R1	NSP
R1144	CHIP TYPE CARBON RESISTOR	RN72K1J-470JE	1	435034704R1	NSP
R1145	CHIP TYPE CARBON RESISTOR	RN72K1J-470JE	1	435034704R1	NSP
R1146	CHIP TYPE CARBON RESISTOR	RN72K1J-470JE	1	435034704R1	NSP
R1147	CHIP TYPE CARBON RESISTOR	RN72K1J-470JE	1	435034704R1	NSP
R1149	CHIP TYPE CARBON RESISTOR	RN72K1J-331JE	1	435033314R1	NSP
R1150	CHIP TYPE CARBON RESISTOR	RN72K1J-331JE	1	435033314R1	NSP
R1154	CHIP TYPE CARBON RESISTOR	RN72K1J-000JE	1	435030004R1	NSP
R1158	CHIP TYPE CARBON RESISTOR	RN72K1J-330JE	1	435033304R1	NSP
R1159	CHIP TYPE CARBON RESISTOR	RN72K1J-103JE	1	435031034R1	NSP
R1160	CHIP TYPE CARBON RESISTOR	RN72K1J-330JE	1	435033304R1	NSP
R1161	CHIP TYPE CARBON RESISTOR	RN72K1J-470JE	1	435034704R1	NSP
R1167	CHIP RESISTOR NETWORK	MNR04MRAPJ470	1	43464747004R2	N NSP
R1167or	CHIP RESISTOR NETWORK	YCN104-470-JK	(1)	43464C47004R1	NSP
R1168	CHIP TYPE CARBON RESISTOR	RN72K1J-470JE	1	435034704R1	NSP
R1171	CHIP TYPE CARBON RESISTOR	RN72K1J-102JE	1	435031024R1	NSP
R1172	CHIP TYPE CARBON RESISTOR	RN72K1J-103JE	1	435031034R1	NSP
R1174	CHIP TYPE CARBON RESISTOR	RN72K1J-000JE	1	435030004R1	NSP
R1176	CHIP TYPE CARBON RESISTOR	RN72K1J-000JE	1	435030004R1	NSP
R1182	CHIP TYPE CARBON RESISTOR	RN72K1J-000JE	1	435030004R1	NSP
R1183	CHIP TYPE CARBON RESISTOR	RN72K1J-000JE	1	435030004R1	NSP
R1184	CHIP TYPE CARBON RESISTOR	RN72K1J-000JE	1	435030004R1	NSP
R1210	CHIP TYPE CARBON RESISTOR	RN72K1J-000JE	1	435030004R1	NSP
R3009	CHIP TYPE CARBON RESISTOR	RN72K1J-102JE	1	435031024R1	NSP
R3010	CHIP TYPE CARBON RESISTOR	RN72K1J-475JE	1	435034754R1	N NSP
R3011	CHIP TYPE CARBON RESISTOR	RN72K1J-105JE	1	435031054R1	NSP
R3012	CHIP TYPE CARBON RESISTOR	RN72K1J-220JE	1	435032204R1	NSP
R3013	CHIP TYPE CARBON RESISTOR	RN72K1J-220JE	1	435032204R1	NSP
R3014	CHIP TYPE CARBON RESISTOR	RN72K1J-220JE	1	435032204R1	NSP
R3015	CHIP TYPE CARBON RESISTOR	RN72K1J-220JE	1	435032204R1	NSP
R3016	CHIP TYPE CARBON RESISTOR	RN72K1J-220JE	1	435032204R1	NSP
R3017	CHIP TYPE CARBON RESISTOR	RN72K1J-220JE	1	435032204R1	NSP
R3018	CHIP TYPE CARBON RESISTOR	RN72K1J-220JE	1	435032204R1	NSP
R3019	CHIP TYPE CARBON RESISTOR	RN72K1J-472JE	1	435034724R1	NSP
R3020	CHIP TYPE CARBON RESISTOR	RN72K1J-103JE	1	435031034R1	NSP
R3021	CHIP TYPE CARBON RESISTOR	RN72K1J-103JE	1	435031034R1	NSP
R3022	CHIP TYPE CARBON RESISTOR	RN72K1J-470JE	1	435034704R1	NSP
R3023	CHIP TYPE CARBON RESISTOR	RN72K1J-470JE	1	435034704R1	NSP
R3028	CHIP TYPE CARBON RESISTOR	RN72K1J-103JE	1	435031034R1	NSP
R3029	CHIP TYPE CARBON RESISTOR	RN72K1J-102JE	1	435031024R1	NSP
R3030	CHIP TYPE CARBON RESISTOR	RN72K1J-223JE	1	435032234R1	NSP
R3031	CHIP TYPE CARBON RESISTOR	RN72K1J-104JE	1	435031044R1	NSP
R3032	CHIP TYPE CARBON RESISTOR	RN72K1J-470JE	1	435034704R1	NSP
R3033	CHIP TYPE CARBON RESISTOR	RN72K1J-470JE	1	435034704R1	NSP
R3034	CHIP TYPE CARBON RESISTOR	RN72K1J-470JE	1	435034704R1	NSP
R3035	CHIP TYPE CARBON RESISTOR	RN72K1J-102JE	1	435031024R1	NSP

R3036	CHIP TYPE CARBON RESISTOR	RN72K1J-470JE	1	435034704R1	NSP
R3037	CHIP TYPE CARBON RESISTOR	RN72K1J-470JE	1	435034704R1	NSP
R3038	CHIP TYPE CARBON RESISTOR	RN72K1J-470JE	1	435034704R1	NSP
R3039	CHIP TYPE CARBON RESISTOR	RN72K1J-470JE	1	435034704R1	NSP
R3040	CHIP TYPE CARBON RESISTOR	MCR03EZPF49R9(49.9_1%)	1	4100037R2	NSP
R3041	CHIP TYPE CARBON RESISTOR	RN72K1J-271FE	1	435032712R1	NSP
R3042	CHIP TYPE CARBON RESISTOR	RN72K1J-222FE	1	435032222R1	NSP
R3043	CHIP TYPE CARBON RESISTOR	RN72K1J-103FE	1	435031032R1	NSP
R3044	CHIP TYPE CARBON RESISTOR	RN72K1J-103FE	1	435031032R1	NSP
R3045	CHIP TYPE CARBON RESISTOR	RN72K1J-102FE	1	435031022R1	NSP
R3046	CHIP TYPE CARBON RESISTOR	RN72K1J-102FE	1	435031022R1	NSP
R3077	CHIP TYPE CARBON RESISTOR	RN72K1J-000JE	1	435030004R1	NSP
R3078	CHIP TYPE CARBON RESISTOR	RN72K1J-000JE	1	435030004R1	NSP
R3079	CHIP TYPE CARBON RESISTOR	RN72K1J-475JE	1	435034754R1	N NSP
R3080	CHIP TYPE CARBON RESISTOR	RN72K1J-475JE	1	435034754R1	N NSP
R3081	CHIP RESISTOR NETWORK	MNR04MRAPJ470	1	43464747004R2	N NSP
R3081or	CHIP RESISTOR NETWORK	YCN104-470-JK	(1)	43464C47004R1	NSP
R3082	CHIP RESISTOR NETWORK	MNR04MRAPJ470	1	43464747004R2	N NSP
R3082or	CHIP RESISTOR NETWORK	YCN104-470-JK	(1)	43464C47004R1	NSP
R3083	CHIP RESISTOR NETWORK	MNR04MRAPJ470	1	43464747004R2	N NSP
R3083or	CHIP RESISTOR NETWORK	YCN104-470-JK	(1)	43464C47004R1	NSP
R3201	CHIP TYPE CARBON RESISTOR	RN72K1J-470JE	1	435034704R1	NSP
R3202	CHIP TYPE CARBON RESISTOR	RN72K1J-470JE	1	435034704R1	NSP
R3203	CHIP TYPE CARBON RESISTOR	RN72K1J-470JE	1	435034704R1	NSP
R3204	CHIP TYPE CARBON RESISTOR	RN72K1J-470JE	1	435034704R1	NSP
R3205	CHIP TYPE CARBON RESISTOR	RN72K1J-470JE	1	435034704R1	NSP
R3206	CHIP TYPE CARBON RESISTOR	RN72K1J-470JE	1	435034704R1	NSP
R3207	CHIP TYPE CARBON RESISTOR	RN72K1J-470JE	1	435034704R1	NSP
R3208	CHIP TYPE CARBON RESISTOR	RN72K1J-470JE	1	435034704R1	NSP
R3209	CHIP TYPE CARBON RESISTOR	RN72K1J-470JE	1	435034704R1	NSP
R3210	CHIP TYPE CARBON RESISTOR	RN72K1J-470JE	1	435034704R1	NSP
R3211	CHIP TYPE CARBON RESISTOR	RN72K1J-470JE	1	435034704R1	NSP
R3212	CHIP TYPE CARBON RESISTOR	RN72K1J-470JE	1	435034704R1	NSP
R3213	CHIP TYPE CARBON RESISTOR	RN72K1J-470JE	1	435034704R1	NSP
R3214	CHIP TYPE CARBON RESISTOR	RN72K1J-470JE	1	435034704R1	NSP
R3215	CHIP TYPE CARBON RESISTOR	RN72K1J-470JE	1	435034704R1	NSP
R3244	CHIP TYPE CARBON RESISTOR	RN72K1J-220JE	1	435032204R1	NSP
R3245	CHIP TYPE CARBON RESISTOR	RN72K1J-220JE	1	435032204R1	NSP
R3246	CHIP TYPE CARBON RESISTOR	RN72K1J-220JE	1	435032204R1	NSP
R3247	CHIP TYPE CARBON RESISTOR	RN72K1J-220JE	1	435032204R1	NSP
R3250	CHIP TYPE CARBON RESISTOR	RN72K1J-220JE	1	435032204R1	NSP
R3251	CHIP TYPE CARBON RESISTOR	RN72K1J-220JE	1	435032204R1	NSP
R3252	CHIP TYPE CARBON RESISTOR	RN72K1J-220JE	1	435032204R1	NSP
R3253	CHIP TYPE CARBON RESISTOR	RN72K1J-220JE	1	435032204R1	NSP
R3254	CHIP TYPE CARBON RESISTOR	RN72K1J-220JE	1	435032204R1	NSP
R3255	CHIP TYPE CARBON RESISTOR	RN72K1J-220JE	1	435032204R1	NSP
R3256	CHIP TYPE CARBON RESISTOR	RN72K1J-220JE	1	435032204R1	NSP
R3257	CHIP TYPE CARBON RESISTOR	RN72K1J-220JE	1	435032204R1	NSP
R3258	CHIP TYPE CARBON RESISTOR	RN72K1J-220JE	1	435032204R1	NSP
R3259	CHIP TYPE CARBON RESISTOR	RN72K1J-220JE	1	435032204R1	NSP
R3260	CHIP TYPE CARBON RESISTOR	RN72K1J-103JE	1	435031034R1	NSP
R3263	CHIP TYPE CARBON RESISTOR	RN72K1J-101JE	1	435031014R1	NSP
R3264	CHIP TYPE CARBON RESISTOR	RN72K1J-101JE	1	435031014R1	NSP
R3265	CHIP TYPE CARBON RESISTOR	RN72K1J-101JE	1	435031014R1	NSP
R3270	CHIP TYPE CARBON RESISTOR	RN72K1J-220JE	1	435032204R1	NSP

R3271	CHIP TYPE CARBON RESISTOR	RN72K1J-220JE	1	435032204R1	NSP
R3276	CHIP TYPE CARBON RESISTOR	RN72K1J-470JE	1	435034704R1	NSP
R3277	CHIP TYPE CARBON RESISTOR	RN72K1J-470JE	1	435034704R1	NSP
R3278	CHIP TYPE CARBON RESISTOR	RN72K1J-470JE	1	435034704R1	NSP
R3279	CHIP TYPE CARBON RESISTOR	RN72K1J-470JE	1	435034704R1	NSP
R3280	CHIP TYPE CARBON RESISTOR	RN72K1J-470JE	1	435034704R1	NSP
R3281	CHIP TYPE CARBON RESISTOR	RN72K1J-470JE	1	435034704R1	NSP
R3296	CHIP TYPE CARBON RESISTOR	RN72K1J-103JE	1	435031034R1	NSP
R3297	CHIP TYPE CARBON RESISTOR	RN72K1J-103JE	1	435031034R1	NSP
R3298	CHIP TYPE CARBON RESISTOR	RN72K1J-103JE	1	435031034R1	NSP
R3299	CHIP TYPE CARBON RESISTOR	RN72K1J-103JE	1	435031034R1	NSP
R3300	CHIP TYPE CARBON RESISTOR	RN72K1J-103JE	1	435031034R1	NSP
R3301	CHIP TYPE CARBON RESISTOR	RN72K1J-103JE	1	435031034R1	NSP
R3302	CHIP TYPE CARBON RESISTOR	RN72K1J-103JE	1	435031034R1	NSP
R3303	CHIP TYPE CARBON RESISTOR	RN72K1J-103JE	1	435031034R1	NSP
R3305	CHIP TYPE CARBON RESISTOR	RN72K1J-103JE	1	435031034R1	NSP
R3307	CHIP TYPE CARBON RESISTOR	RN72K1J-183JE	1	435031834R1	NSP
R3310	CHIP TYPE CARBON RESISTOR	RN72K1J-183JE	1	435031834R1	NSP
R3311	CHIP TYPE CARBON RESISTOR	RN72K1J-183JE	1	435031834R1	NSP
R3320	CHIP TYPE CARBON RESISTOR	RN72K1J-183JE	1	435031834R1	NSP
R3322	CHIP TYPE CARBON RESISTOR	RN72K1J-470JE	1	435034704R1	NSP
R3323	CHIP TYPE CARBON RESISTOR	RN72K1J-470JE	1	435034704R1	NSP
R3324	CHIP TYPE CARBON RESISTOR	RN72K1J-220JE	1	435032204R1	NSP
R3325	CHIP RESISTOR NETWORK	MNR04MRAPJ470	1	43464747004R2	N NSP
R3325or	CHIP RESISTOR NETWORK	YCN104-470-JK	(1)	43464C47004R1	NSP
R3326	CHIP TYPE CARBON RESISTOR	RN72K1J-470JE	1	435034704R1	NSP
R3327	CHIP TYPE CARBON RESISTOR	RN72K1J-470JE	1	435034704R1	NSP
R3328	CHIP TYPE CARBON RESISTOR	RN72K1J-470JE	1	435034704R1	NSP
R3329	CHIP TYPE CARBON RESISTOR	RN72K1J-470JE	1	435034704R1	NSP
R3330	CHIP TYPE CARBON RESISTOR	RN72K1J-220JE	1	435032204R1	NSP
R3331	CHIP TYPE CARBON RESISTOR	RN72K1J-220JE	1	435032204R1	NSP
R3332	CHIP TYPE CARBON RESISTOR	RN72K1J-470JE	1	435034704R1	NSP
R3333	CHIP TYPE CARBON RESISTOR	RN72K1J-470JE	1	435034704R1	NSP
R3334	CHIP TYPE CARBON RESISTOR	RN72K1J-470JE	1	435034704R1	NSP
R3335	CHIP TYPE CARBON RESISTOR	RN72K1J-470JE	1	435034704R1	NSP
R3336	CHIP TYPE CARBON RESISTOR	RN72K1J-470JE	1	435034704R1	NSP
R3337	CHIP TYPE CARBON RESISTOR	RN72K1J-470JE	1	435034704R1	NSP
R3338	CHIP TYPE CARBON RESISTOR	RN72K1J-470JE	1	435034704R1	NSP
R3339	CHIP TYPE CARBON RESISTOR	RN72K1J-470JE	1	435034704R1	NSP
R3340	CHIP TYPE CARBON RESISTOR	RN72K1J-470JE	1	435034704R1	NSP
R3341	CHIP TYPE CARBON RESISTOR	RN72K1J-470JE	1	435034704R1	NSP
R3342	CHIP TYPE CARBON RESISTOR	RN72K1J-470JE	1	435034704R1	NSP
R3343	CHIP TYPE CARBON RESISTOR	RN72K1J-470JE	1	435034704R1	NSP
R3344	CHIP TYPE CARBON RESISTOR	RN72K1J-470JE	1	435034704R1	NSP
R3345	CHIP TYPE CARBON RESISTOR	RN72K1J-220JE	1	435032204R1	NSP
R3346	CHIP TYPE CARBON RESISTOR	RN72K1J-470JE	1	435034704R1	NSP
R3347	CHIP TYPE CARBON RESISTOR	RN72K1J-103JE	1	435031034R1	NSP
R3348	CHIP TYPE CARBON RESISTOR	RN72K1J-470JE	1	435034704R1	NSP
R3349	CHIP TYPE CARBON RESISTOR	RN72K1J-472JE	1	435034724R1	NSP
R3350	CHIP TYPE CARBON RESISTOR	RN72K1J-472JE	1	435034724R1	NSP
R3351	CHIP RESISTOR NETWORK	MNR04MRAPJ103	1	43464710304R2	N NSP
R3351or	CHIP RESISTOR NETWORK	YCN104-103-JK	(1)	43464C10304R1	NSP
R3352	CHIP RESISTOR NETWORK	MNR04MRAPJ103	1	43464710304R2	N NSP
R3352or	CHIP RESISTOR NETWORK	YCN104-103-JK	(1)	43464C10304R1	NSP
R3353	CHIP RESISTOR NETWORK	MNR04MRAPJ220	1	43464722004R2	N NSP

R3353or	CHIP RESISTOR NETWORK	YCN104-220-JK	(1)	43464C22004R1	NSP
R3354	CHIP RESISTOR NETWORK	MNR04MRAPJ220	1	43464722004R2	N NSP
R3354or	CHIP RESISTOR NETWORK	YCN104-220-JK	(1)	43464C22004R1	NSP
R3355	CHIP RESISTOR NETWORK	MNR04MRAPJ220	1	43464722004R2	N NSP
R3355or	CHIP RESISTOR NETWORK	YCN104-220-JK	(1)	43464C22004R1	NSP
R3356	CHIP RESISTOR NETWORK	MNR04MRAPJ220	1	43464722004R2	N NSP
R3356or	CHIP RESISTOR NETWORK	YCN104-220-JK	(1)	43464C22004R1	NSP
R3357	CHIP TYPE CARBON RESISTOR	RN72K1J-103JE	1	435031034R1	NSP
R3358	CHIP TYPE CARBON RESISTOR	RN72K1J-103JE	1	435031034R1	NSP
R3360	CHIP TYPE CARBON RESISTOR	RN72K1J-472JE	1	435034724R1	NSP
R3361	CHIP TYPE CARBON RESISTOR	RN72K1J-103JE	1	435031034R1	NSP
R3366	CHIP TYPE CARBON RESISTOR	RN72K1J-000JE	1	435030004R1	NSP
R3367	CHIP TYPE CARBON RESISTOR	RN72K1J-470JE	1	435034704R1	NSP
R3369	CHIP TYPE CARBON RESISTOR	RN72K1J-472JE	1	435034724R1	NSP
R3373	CHIP TYPE CARBON RESISTOR	RN72K1J-472JE	1	435034724R1	NSP
R3375	CHIP TYPE CARBON RESISTOR	RN72K1J-000JE	1	435030004R1	NSP
R3377	CHIP TYPE CARBON RESISTOR	RN72K1J-000JE	1	435030004R1	NSP
R3400	CHIP TYPE CARBON RESISTOR	RN72K1J-103JE	1	435031034R1	NSP
R3401	CHIP TYPE CARBON RESISTOR	RN72K1J-470JE	1	435034704R1	NSP
R3403	CHIP TYPE CARBON RESISTOR	RN72K1J-221JE	1	435032214R1	NSP
R3404	CHIP TYPE CARBON RESISTOR	RN72K1J-470JE	1	435034704R1	NSP
R3405	CHIP TYPE CARBON RESISTOR	RN72K1J-470JE	1	435034704R1	NSP
R3406	CHIP TYPE CARBON RESISTOR	RN72K1J-332JE	1	435033324R1	NSP
R3407	CHIP TYPE CARBON RESISTOR	RN72K1J-222JE	1	435032224R1	NSP
R3408	CHIP RESISTOR NETWORK	MNR04MRAPJ221	1	43464722104R2	N NSP
R3408or	CHIP RESISTOR NETWORK	YCN104-221-JK	(1)	43464C22104R1	NSP
R3409	CHIP RESISTOR NETWORK	MNR04MRAPJ221	1	43464722104R2	N NSP
R3409or	CHIP RESISTOR NETWORK	YCN104-221-JK	(1)	43464C22104R1	NSP
R3411	CHIP RESISTOR NETWORK	MNR04MRAPJ000	1	43464700004R2	N NSP
R3411or	CHIP RESISTOR NETWORK	YCN104-000-ZK	(1)	43484C00004R1	NSP
R3412	CHIP TYPE CARBON RESISTOR	RN72K1J-472JE	1	435034724R1	NSP
R3414	CHIP TYPE CARBON RESISTOR	RN72K1J-103JE	1	435031034R1	NSP
R3415	CHIP RESISTOR NETWORK	MNR04MRAPJ000	1	43464700004R2	N NSP
R3415or	CHIP RESISTOR NETWORK	YCN104-000-ZK	(1)	43484C00004R1	NSP
R3421	CHIP TYPE CARBON RESISTOR	RN72K1J-470JE	1	435034704R1	NSP
R3424	CHIP TYPE CARBON RESISTOR	RN72K1J-470JE	1	435034704R1	NSP
R3425	CHIP TYPE CARBON RESISTOR	RN72K1J-470JE	1	435034704R1	NSP
R3428	CHIP TYPE CARBON RESISTOR	RN72K1J-472JE	1	435034724R1	NSP
R3429	CHIP RESISTOR NETWORK	MNR04MRAPJ470	1	43464747004R2	N NSP
R3429or	CHIP RESISTOR NETWORK	YCN104-470-JK	(1)	43464C47004R1	NSP
R3430	CHIP RESISTOR NETWORK	MNR04MRAPJ470	1	43464747004R2	N NSP
R3430or	CHIP RESISTOR NETWORK	YCN104-470-JK	(1)	43464C47004R1	NSP
R3433	CHIP TYPE CARBON RESISTOR	RN72K1J-103JE	1	435031034R1	NSP
R3434	CHIP TYPE CARBON RESISTOR	RN72K1J-332JE	1	435033324R1	NSP
R3435	CHIP TYPE CARBON RESISTOR	RN72K1J-222JE	1	435032224R1	NSP
R3436	CHIP TYPE CARBON RESISTOR	RN72K1J-101JE	1	435031014R1	NSP
R3437	CHIP TYPE CARBON RESISTOR	RN72K1J-470JE	1	435034704R1	NSP
R3438	CHIP TYPE CARBON RESISTOR	RN72K1J-470JE	1	435034704R1	NSP
R3439	CHIP TYPE CARBON RESISTOR	RN72K1J-332JE	1	435033324R1	NSP
R3440	CHIP TYPE CARBON RESISTOR	RN72K1J-332JE	1	435033324R1	NSP
R3441	CHIP RESISTOR NETWORK	MNR04MRAPJ470	1	43464747004R2	N NSP
R3441or	CHIP RESISTOR NETWORK	YCN104-470-JK	(1)	43464C47004R1	NSP
R3442	CHIP TYPE CARBON RESISTOR	RN72K1J-105JE	1	435031054R1	NSP
R3443	CHIP TYPE CARBON RESISTOR	RN72K1J-000JE	1	435030004R1	NSP
R3444	CHIP TYPE CARBON RESISTOR	RN72K1J-470JE	1	435034704R1	NSP

R3445	CHIP RESISTOR NETWORK	MNR04MRAPJ470	1	43464747004R2	N	NSP
R3445or	CHIP RESISTOR NETWORK	YCN104-470-JK	(1)	43464C47004R1		NSP
R3446	CHIP TYPE CARBON RESISTOR	RN72K1J-102JE	1	435031024R1		NSP
R3447	CHIP TYPE CARBON RESISTOR	RN72K1J-470JE	1	435034704R1		NSP
R3448	CHIP TYPE CARBON RESISTOR	RN72K1J-470JE	1	435034704R1		NSP
R3450	CHIP TYPE CARBON RESISTOR	RN72K1J-470JE	1	435034704R1		NSP
R3452	CHIP TYPE CARBON RESISTOR	RN72K1J-470JE	1	435034704R1		NSP
R3453	CHIP TYPE CARBON RESISTOR	RN72K1J-221JE	1	435032214R1		NSP
R3454	CHIP TYPE CARBON RESISTOR	RN72K1J-470JE	1	435034704R1		NSP
R3455	CHIP TYPE CARBON RESISTOR	RN72K1J-101JE	1	435031014R1		NSP
R3456	CHIP TYPE CARBON RESISTOR	RN72K1J-470JE	1	435034704R1		NSP
R3457	CHIP RESISTOR NETWORK	MNR04MRAPJ470	1	43464747004R2	N	NSP
R3457or	CHIP RESISTOR NETWORK	YCN104-470-JK	(1)	43464C47004R1		NSP
R3462	CHIP TYPE CARBON RESISTOR	RN72K1J-102JE	1	435031024R1		NSP
R3464	CHIP TYPE CARBON RESISTOR	RN72K1J-102JE	1	435031024R1		NSP
R3465	CHIP TYPE CARBON RESISTOR	RN72K1J-102JE	1	435031024R1		NSP
R3466	CHIP TYPE CARBON RESISTOR	RN72K1J-102JE	1	435031024R1		NSP
R3469	CHIP TYPE CARBON RESISTOR	RN72K1J-222JE	1	435032224R1		NSP
R3470	CHIP TYPE CARBON RESISTOR	RN72K1J-222JE	1	435032224R1		NSP
R3473	CHIP TYPE CARBON RESISTOR	RN72K1J-103JE	1	435031034R1		NSP
R3474	CHIP TYPE CARBON RESISTOR	RN72K1J-103JE	1	435031034R1		NSP
R3481	CHIP TYPE CARBON RESISTOR	RN72K1J-332JE	1	435033324R1		NSP
R3484	CHIP TYPE CARBON RESISTOR	RN72K1J-470JE	1	435034704R1		NSP
R3485	CHIP TYPE CARBON RESISTOR	RN72K1J-470JE	1	435034704R1		NSP
R3488	CHIP TYPE CARBON RESISTOR	RN72K1J-332JE	1	435033324R1		NSP
R3491	CHIP TYPE CARBON RESISTOR	RN72K1J-332JE	1	435033324R1		NSP
R3494	CHIP RESISTOR NETWORK	MNR04MRAPJ470	1	43464747004R2	N	NSP
R3494or	CHIP RESISTOR NETWORK	YCN104-470-JK	(1)	43464C47004R1		NSP
R3495	CHIP RESISTOR NETWORK	MNR04MRAPJ470	1	43464747004R2	N	NSP
R3495or	CHIP RESISTOR NETWORK	YCN104-470-JK	(1)	43464C47004R1		NSP
R3496	CHIP RESISTOR NETWORK	MNR04MRAPJ470	1	43464747004R2	N	NSP
R3496or	CHIP RESISTOR NETWORK	YCN104-470-JK	(1)	43464C47004R1		NSP
R3497	CHIP RESISTOR NETWORK	MNR04MRAPJ470	1	43464747004R2	N	NSP
R3497or	CHIP RESISTOR NETWORK	YCN104-470-JK	(1)	43464C47004R1		NSP
R3500	CHIP TYPE CARBON RESISTOR	RN72K1J-470JE	1	435034704R1		NSP
R3501	CHIP TYPE CARBON RESISTOR	RN72K1J-470JE	1	435034704R1		NSP
R3502	CHIP TYPE CARBON RESISTOR	RN72K1J-470JE	1	435034704R1		NSP
R3503	CHIP TYPE CARBON RESISTOR	RN72K1J-470JE	1	435034704R1		NSP
R3504	CHIP TYPE CARBON RESISTOR	RN72K1J-470JE	1	435034704R1		NSP
R3505	CHIP TYPE CARBON RESISTOR	RN72K1J-470JE	1	435034704R1		NSP
R3601	CHIP TYPE CARBON RESISTOR	RN72K1J-103JE	1	435031034R1		NSP
R3603	CHIP TYPE CARBON RESISTOR	RN72K1J-103JE	1	435031034R1		NSP
R3604	CHIP TYPE CARBON RESISTOR	RN72K1J-103JE	1	435031034R1		NSP
R3605	CHIP TYPE CARBON RESISTOR	RN72K1J-102JE	1	435031024R1		NSP
R3652	CHIP TYPE CARBON RESISTOR	RN72K1J-220JE	1	435032204R1		NSP
R3653	CHIP TYPE CARBON RESISTOR	RN72K1J-102JE	1	435031024R1		NSP
R3654	CHIP TYPE CARBON RESISTOR	RN72K1J-102JE	1	435031024R1		NSP
R3657	CHIP TYPE CARBON RESISTOR	RN72K1J-220JE	1	435032204R1		NSP
R3658	CHIP TYPE CARBON RESISTOR	RN72K1J-391FE	1	435033912R1		NSP
R3659	CHIP TYPE CARBON RESISTOR	RN72K1J-222FE	1	435032222R1		NSP
R3660	CHIP TYPE CARBON RESISTOR	RN72K1J-392FE	1	435033922R1		NSP
R3661	CHIP TYPE CARBON RESISTOR	RN72K1J-220JE	1	435032204R1		NSP
R3662	CHIP TYPE CARBON RESISTOR	RN72K1J-220JE	1	435032204R1		NSP
R3663	CHIP TYPE CARBON RESISTOR	RN72K1J-472JE	1	435034724R1		NSP
R3664	CHIP TYPE CARBON RESISTOR	RN72K1J-220JE	1	435032204R1		NSP

R3903	CHIP TYPE CARBON RESISTOR	RN72K1J-103JE	1	435031034R1	NSP
R3904	CHIP TYPE CARBON RESISTOR	RN72K1J-122JE	1	435031224R1	NSP
R3905	CHIP TYPE CARBON RESISTOR	RN72K1J-122JE	1	435031224R1	NSP
R3906	CHIP TYPE CARBON RESISTOR	RN72K1J-103JE	1	435031034R1	NSP
R3908	CHIP TYPE CARBON RESISTOR	RN72K1J-103JE	1	435031034R1	NSP
R3911	CHIP TYPE CARBON RESISTOR	RN72K1J-000JE	1	435030004R1	NSP
R3912	CHIP TYPE CARBON RESISTOR	RN72K1J-000JE	1	435030004R1	NSP
R3915	CHIP TYPE CARBON RESISTOR	RN72K1J-000JE	1	435030004R1	NSP
R3916	CHIP TYPE CARBON RESISTOR	RN72K1J-000JE	1	435030004R1	NSP
R3917	CHIP TYPE CARBON RESISTOR	RN72K1J-000JE	1	435030004R1	NSP
R3918	CHIP TYPE CARBON RESISTOR	RN72K1J-000JE	1	435030004R1	NSP
R3920	CHIP TYPE CARBON RESISTOR	RN72K1J-470JE	1	435034704R1	NSP
R7000	CHIP TYPE CARBON RESISTOR	RN72K1J-472JE	1	435034724R1	NSP
R7001	CHIP RESISTOR NETWORK	MNR04MRAPJ470	1	43464747004R2	N NSP
R7001or	CHIP RESISTOR NETWORK	YCN104-470-JK	(1)	43464C47004R1	NSP
R7002	CHIP TYPE CARBON RESISTOR	RN72K1J-103JE	1	435031034R1	NSP
R7003	CHIP TYPE CARBON RESISTOR	RN72K1J-103JE	1	435031034R1	NSP
R7004	CHIP TYPE CARBON RESISTOR	RN72K1J-472JE	1	435034724R1	NSP
R7005	CHIP TYPE CARBON RESISTOR	RN72K1J-223JE	1	435032234R1	NSP
R7006	CHIP TYPE CARBON RESISTOR	RN72K1J-223JE	1	435032234R1	NSP
R7007	CHIP TYPE CARBON RESISTOR	RN72K1J-105JE	1	435031054R1	NSP
R7008	CHIP TYPE CARBON RESISTOR	RN72K1J-473JE	1	435034734R1	NSP
R7009	CHIP TYPE CARBON RESISTOR	RN72K1J-105JE	1	435031054R1	NSP
R7011	CHIP TYPE CARBON RESISTOR	RN72K1J-103JE	1	435031034R1	NSP
R7012	CHIP TYPE CARBON RESISTOR	RN72K1J-103JE	1	435031034R1	NSP
R7013	CHIP TYPE CARBON RESISTOR	RN72K1J-103JE	1	435031034R1	NSP
R7014	CHIP TYPE CARBON RESISTOR	RN72K1J-473JE	1	435034734R1	NSP
R7015	CHIP TYPE CARBON RESISTOR	RN72K1J-473JE	1	435034734R1	NSP
R7016	CHIP TYPE CARBON RESISTOR	RN72K1J-473JE	1	435034734R1	NSP
R7017	CHIP RESISTOR NETWORK	MNR04MRAPJ472	1	43464747204R2	N NSP
R7017or	CHIP RESISTOR NETWORK	YCN104-472-JK	(1)	43464C47204R1	NSP
R7018	CHIP TYPE CARBON RESISTOR	RN72K1J-221JE	1	435032214R1	NSP
R7019	CHIP RESISTOR NETWORK	MNR04MRAPJ221	1	43464722104R2	N NSP
R7019or	CHIP RESISTOR NETWORK	YCN104-221-JK	(1)	43464C22104R1	NSP
R7020	CHIP TYPE CARBON RESISTOR	RN72K1J-221JE	1	435032214R1	NSP
R7021	CHIP RESISTOR NETWORK	MNR04MRAPJ221	1	43464722104R2	N NSP
R7021or	CHIP RESISTOR NETWORK	YCN104-221-JK	(1)	43464C22104R1	NSP
R7022	CHIP TYPE CARBON RESISTOR	RN72K1J-470JE	1	435034704R1	NSP
R7023	CHIP TYPE CARBON RESISTOR	RN72K1J-224JE	1	435032244R1	NSP
R7024	CHIP TYPE CARBON RESISTOR	RN72K1J-470JE	1	435034704R1	NSP
R7025	CHIP TYPE CARBON RESISTOR	RN72K1J-224JE	1	435032244R1	NSP
R7026	CHIP TYPE CARBON RESISTOR	RN72K1J-224JE	1	435032244R1	NSP
R7027	CHIP TYPE CARBON RESISTOR	RN72K1J-470JE	1	435034704R1	NSP
R7028	CHIP TYPE CARBON RESISTOR	RN72K1J-470JE	1	435034704R1	NSP
R7029	CHIP TYPE CARBON RESISTOR	RN72K1J-102JE	1	435031024R1	NSP
R7030	CHIP TYPE CARBON RESISTOR	RN72K1J-221JE	1	435032214R1	NSP
R7031	CHIP RESISTOR NETWORK	MNR04MRAPJ221	1	43464722104R2	N NSP
R7031or	CHIP RESISTOR NETWORK	YCN104-221-JK	(1)	43464C22104R1	NSP
R7032	CHIP TYPE CARBON RESISTOR	RN72K1J-470JE	1	435034704R1	NSP
R7033	CHIP RESISTOR NETWORK	MNR04MRAPJ470	1	43464747004R2	N NSP
R7033or	CHIP RESISTOR NETWORK	YCN104-470-JK	(1)	43464C47004R1	NSP
R7034	CHIP RESISTOR NETWORK	MNR04MRAPJ221	1	43464722104R2	N NSP
R7034or	CHIP RESISTOR NETWORK	YCN104-221-JK	(1)	43464C22104R1	NSP
R7035	CHIP TYPE CARBON RESISTOR	RN72K1J-470JE	1	435034704R1	NSP
R7036	CHIP TYPE CARBON RESISTOR	RN72K1J-102JE	1	435031024R1	NSP

R7037	CHIP TYPE CARBON RESISTOR	RN72K1J-102JE	1	435031024R1	NSP
R7038	CHIP TYPE CARBON RESISTOR	RN72K1J-102JE	1	435031024R1	NSP
R7039	CHIP TYPE CARBON RESISTOR	RN72K1J-222JE	1	435032224R1	NSP
R7040	CHIP TYPE CARBON RESISTOR	RN72K1J-222JE	1	435032224R1	NSP
R7041	CHIP TYPE CARBON RESISTOR	RN72K1J-222JE	1	435032224R1	NSP
R7042	CHIP RESISTOR NETWORK	MNR04MRAPJ221	1	43464722104R2	N NSP
R7042or	CHIP RESISTOR NETWORK	YCN104-221-JK	(1)	43464C22104R1	NSP
R7044	CHIP TYPE CARBON RESISTOR	RN72K1J-470JE	1	435034704R1	NSP
R7046	CHIP TYPE CARBON RESISTOR	RN72K1J-221JE	1	435032214R1	NSP
R7048	CHIP TYPE CARBON RESISTOR	RN72K1J-221JE	1	435032214R1	NSP
R7049	CHIP TYPE CARBON RESISTOR	RN72K1J-470JE	1	435034704R1	NSP
R7050	CHIP TYPE CARBON RESISTOR	RN72K1J-103JE	1	435031034R1	NSP
R7051	CHIP TYPE CARBON RESISTOR	RN72K1J-105JE	1	435031054R1	NSP
R7052	CHIP TYPE CARBON RESISTOR	RN72K1J-223JE	1	435032234R1	NSP
R7054	CHIP TYPE CARBON RESISTOR	RN72K1J-102JE	1	435031024R1	NSP
R7055	CHIP TYPE CARBON RESISTOR	RN72K1J-102JE	1	435031024R1	NSP
R7059	CHIP TYPE CARBON RESISTOR	RN72K1J-224JE	1	435032244R1	NSP
R7060	CHIP TYPE CARBON RESISTOR	RN72K1J-473JE	1	435034734R1	NSP
R7061	CHIP RESISTOR NETWORK	MNR04MRAPJ221	1	43464722104R2	N NSP
R7061or	CHIP RESISTOR NETWORK	YCN104-221-JK	(1)	43464C22104R1	NSP
R7062	CHIP TYPE CARBON RESISTOR	RN72K1J-103JE	1	435031034R1	NSP
R7065	CHIP TYPE CARBON RESISTOR	RN72K1J-473JE	1	435034734R1	NSP
R7066	CHIP TYPE CARBON RESISTOR	RN72K1J-470JE	1	435034704R1	NSP
R7067	CHIP TYPE CARBON RESISTOR	RN72K1J-000JE	1	435030004R1	NSP
R7068	CHIP TYPE CARBON RESISTOR	RN72K1J-000JE	1	435030004R1	NSP
R7069	CHIP RESISTOR NETWORK	MNR04MRAPJ470	1	43464747004R2	N NSP
R7069or	CHIP RESISTOR NETWORK	YCN104-470-JK	(1)	43464C47004R1	NSP
R7070	CHIP RESISTOR NETWORK	MNR04MRAPJ221	1	43464722104R2	N NSP
R7070or	CHIP RESISTOR NETWORK	YCN104-221-JK	(1)	43464C22104R1	NSP
R7071	CHIP TYPE CARBON RESISTOR	RN72K1J-103JE	1	435031034R1	NSP
R7072	CHIP TYPE CARBON RESISTOR	RN72K1J-470JE	1	435034704R1	NSP
R7073	CHIP TYPE CARBON RESISTOR	RN72K1J-102JE	1	435031024R1	NSP
R7074	CHIP TYPE CARBON RESISTOR	RN72K1J-470JE	1	435034704R1	NSP
R7075	CHIP RESISTOR NETWORK	MNR04MRAPJ470	1	43464747004R2	N NSP
R7075or	CHIP RESISTOR NETWORK	YCN104-470-JK	(1)	43464C47004R1	NSP
R7076	CHIP TYPE CARBON RESISTOR	RN72K1J-221JE	1	435032214R1	NSP
R7077	CHIP TYPE CARBON RESISTOR	RN72K1J-103JE	1	435031034R1	NSP
R7078	CHIP TYPE CARBON RESISTOR	RN72K1J-103JE	1	435031034R1	NSP
R7079	CHIP RESISTOR NETWORK	MNR04MRAPJ221	1	43464722104R2	N NSP
R7079or	CHIP RESISTOR NETWORK	YCN104-221-JK	(1)	43464C22104R1	NSP
R7080	CHIP TYPE CARBON RESISTOR	RN72K1J-103JE	1	435031034R1	NSP
R7081	CHIP RESISTOR NETWORK	MNR04MRAPJ221	1	43464722104R2	N NSP
R7081or	CHIP RESISTOR NETWORK	YCN104-221-JK	(1)	43464C22104R1	NSP
R7082	CHIP TYPE CARBON RESISTOR	RN72K1J-104JE	1	435031044R1	NSP
R7083	CHIP TYPE CARBON RESISTOR	RN72K1J-332JE	1	435033324R1	NSP
R7084	CHIP TYPE CARBON RESISTOR	RN72K1J-331JE	1	435033314R1	NSP
R7087	CHIP TYPE CARBON RESISTOR	RN72K1J-273JE	1	435032734R1	NSP
R7091	CHIP TYPE CARBON RESISTOR	RN72K1J-221JE	1	435032214R1	NSP
R7092	CHIP TYPE CARBON RESISTOR	RN72K1J-470JE	1	435034704R1	NSP
R7093	CHIP TYPE CARBON RESISTOR	RN72K1J-472JE	1	435034724R1	NSP
R7094	CHIP TYPE CARBON RESISTOR	RN72K1J-472JE	1	435034724R1	NSP
R7095	CHIP RESISTOR NETWORK	MNR04MRAPJ221	1	43464722104R2	N NSP
R7095or	CHIP RESISTOR NETWORK	YCN104-221-JK	(1)	43464C22104R1	NSP
R7097	CHIP TYPE CARBON RESISTOR	RN72K1J-470JE	1	435034704R1	NSP
R7098	CHIP RESISTOR NETWORK	MNR04MRAPJ221	1	43464722104R2	N NSP

R7098or	CHIP RESISTOR NETWORK	YCN104-221-JK	(1)	43464C22104R1	NSP
R7099	CHIP RESISTOR NETWORK	MNR04MRAPJ470	1	43464747004R2	N NSP
R7099or	CHIP RESISTOR NETWORK	YCN104-470-JK	(1)	43464C47004R1	NSP
R7100	CHIP TYPE CARBON RESISTOR	RN72K1J-104JE	1	435031044R1	NSP
R7101	CHIP TYPE CARBON RESISTOR	RN72K1J-221JE	1	435032214R1	NSP
R7103	CHIP TYPE CARBON RESISTOR	RN72K1J-221JE	1	435032214R1	NSP
R7104	CHIP TYPE CARBON RESISTOR	RN72K1J-470JE	1	435034704R1	NSP
R7105	CHIP RESISTOR NETWORK	MNR04MRAPJ470	1	43464747004R2	N NSP
R7105or	CHIP RESISTOR NETWORK	YCN104-470-JK	(1)	43464C47004R1	NSP
R7106	CHIP TYPE CARBON RESISTOR	RN72K1J-473JE	1	435034734R1	NSP
R7108	CHIP RESISTOR NETWORK	MNR04MRAPJ103	1	43464710304R2	N NSP
R7108or	CHIP RESISTOR NETWORK	YCN104-103-JK	(1)	43464C10304R1	NSP
R7110	CHIP TYPE CARBON RESISTOR	RN72K1J-103JE	1	435031034R1	NSP
R7113	CHIP TYPE CARBON RESISTOR	RN72K1J-470JE	1	435034704R1	NSP
R7121	CHIP TYPE CARBON RESISTOR	RN72K1J-105JE	1	435031054R1	NSP
R7122	CHIP TYPE CARBON RESISTOR	RN72K1J-105JE	1	435031054R1	NSP
R7123	CHIP RESISTOR NETWORK	MNR04MRAPJ221	1	43464722104R2	N NSP
R7123or	CHIP RESISTOR NETWORK	YCN104-221-JK	(1)	43464C22104R1	NSP
R7124	CHIP TYPE CARBON RESISTOR	RN72K1J-000JE	1	435030004R1	NSP
R7125	CHIP TYPE CARBON RESISTOR	RN72K1J-473JE	1	435034734R1	NSP
R7128	CHIP TYPE CARBON RESISTOR	RN72K1J-000JE	1	435030004R1	NSP
R7132	CHIP TYPE CARBON RESISTOR	RN72K1J-331JE	1	435033314R1	NSP
R7133	CHIP TYPE CARBON RESISTOR	RN72K1J-221JE	1	435032214R1	NSP
R7134	CHIP TYPE CARBON RESISTOR	RN72K1J-221JE	1	435032214R1	NSP
R7135	CHIP TYPE CARBON RESISTOR	RN72K1J-103JE	1	435031034R1	NSP
R7136	CHIP TYPE CARBON RESISTOR	RN72K1J-470JE	1	435034704R1	NSP
R7137	CHIP TYPE CARBON RESISTOR	RN72K1J-221JE	1	435032214R1	NSP
R7138	CHIP TYPE CARBON RESISTOR	RN72K1J-470JE	1	435034704R1	NSP
R7139	CHIP TYPE CARBON RESISTOR	RN72K1J-000JE	1	435030004R1	NSP
R7140	CHIP TYPE CARBON RESISTOR	RN72K1J-103JE	1	435031034R1	NSP
R7141	CHIP TYPE CARBON RESISTOR	RN72K1J-103JE	1	435031034R1	NSP
R7142	CHIP TYPE CARBON RESISTOR	RN72K1J-470JE	1	435034704R1	NSP
R7148	CHIP TYPE CARBON RESISTOR	RN72K1J-000JE	1	435030004R1	NSP
R7161	CHIP TYPE CARBON RESISTOR	RN72K1J-103JE	1	435031034R1	NSP
R7171	CHIP TYPE CARBON RESISTOR	RN72K1J-473JE	1	435034734R1	NSP
R7180	CHIP TYPE CARBON RESISTOR	RN72K1J-272JE	1	435032724R1	NSP
R7181	CHIP TYPE CARBON RESISTOR	RN72K1J-272JE	1	435032724R1	NSP
R7182	CHIP TYPE CARBON RESISTOR	RN72K1J-272JE	1	435032724R1	NSP
R7183	CHIP TYPE CARBON RESISTOR	RN72K1J-272JE	1	435032724R1	NSP
R7184	CHIP TYPE CARBON RESISTOR	RN72K1J-103JE	1	435031034R1	NSP
R7186	CHIP TYPE CARBON RESISTOR	RN72K1J-104JE	1	435031044R1	NSP
R7187	CHIP TYPE CARBON RESISTOR	RN72K1J-104JE	1	435031044R1	NSP
R7188	CHIP TYPE CARBON RESISTOR	RN72K1J-104JE	1	435031044R1	NSP
R7193	CHIP TYPE CARBON RESISTOR	RN72K1J-470JE	1	435034704R1	NSP
R8011	CHIP TYPE CARBON RESISTOR	RN72K1J-473JE	1	435034734R1	NSP
R8012	CHIP TYPE CARBON RESISTOR	RN72K1J-473JE	1	435034734R1	NSP
R8013	CHIP TYPE CARBON RESISTOR	RN72K1J-473JE	1	435034734R1	NSP
R8021	CHIP TYPE CARBON RESISTOR	RN72K1J-182JE	1	435031824R1	NSP
R8022	CHIP TYPE CARBON RESISTOR	RN72K1J-182JE	1	435031824R1	NSP
R8024	CHIP TYPE CARBON RESISTOR	RN72K1J-473JE	1	435034734R1	NSP
R8025	CHIP TYPE CARBON RESISTOR	RN72K1J-560JE	1	435035604R1	NSP
R8030	CHIP TYPE CARBON RESISTOR	RN72K1J-473JE	1	435034734R1	NSP
R8033	CHIP TYPE CARBON RESISTOR	RN72K1J-000JE	1	435030004R1	NSP
R8035	CHIP TYPE CARBON RESISTOR	RN72K1J-000JE	1	435030004R1	NSP
R8037	CHIP TYPE CARBON RESISTOR	RN72K1J-102JE	1	435031024R1	NSP

R8038	CHIP TYPE CARBON RESISTOR	RN72K1J-102JE	1	435031024R1	NSP
R8204	CHIP TYPE CARBON RESISTOR	RN72K1J-330JE	1	435033304R1	NSP
R8208	CHIP TYPE CARBON RESISTOR	RN72K1J-561JE	1	435035614R1	NSP
R8209	CHIP TYPE CARBON RESISTOR	RN72K1J-472JE	1	435034724R1	NSP
R8215	CHIP TYPE CARBON RESISTOR	RN72K1J-561JE	1	435035614R1	NSP
R8218	CHIP TYPE CARBON RESISTOR	RN72K1J-561JE	1	435035614R1	NSP
R8220	CHIP TYPE CARBON RESISTOR	RN72K1J-471JE	1	435034714R1	NSP
R8221	CHIP TYPE CARBON RESISTOR	RN72K1J-471JE	1	435034714R1	NSP
R8223	CHIP TYPE CARBON RESISTOR	RN72K1J-471JE	1	435034714R1	NSP
R8225	CHIP TYPE CARBON RESISTOR	RN72K1J-000JE	1	435030004R1	NSP
R8226	CHIP TYPE CARBON RESISTOR	RN72K1J-000JE	1	435030004R1	NSP
R8228	CHIP TYPE CARBON RESISTOR	RN72K1J-000JE	1	435030004R1	NSP
R8233	CHIP TYPE CARBON RESISTOR	RN72K1J-000JE	1	435030004R1	NSP
R8237	CHIP TYPE CARBON RESISTOR	RN72K1J-105JE	1	435031054R1	NSP
R8238	CHIP TYPE CARBON RESISTOR	RN72K1J-331JE	1	435033314R1	NSP
R8240	CHIP TYPE CARBON RESISTOR	RN72K1J-681JE	1	435036814R1	NSP
R8243	CHIP TYPE CARBON RESISTOR	RN72K1J-681JE	1	435036814R1	NSP
R8244	CHIP TYPE CARBON RESISTOR	RN72K1J-330JE	1	435033304R1	NSP
R8300	CHIP TYPE CARBON RESISTOR	RN72K1J-220JE	1	435032204R1	NSP
R8301	CHIP TYPE CARBON RESISTOR	RN72K1J-220JE	1	435032204R1	NSP
R8302	CHIP TYPE CARBON RESISTOR	RN72K1J-103JE	1	435031034R1	NSP
R8303	CHIP TYPE CARBON RESISTOR	RN72K1J-562JE	1	435035624R1	NSP
R8304	CHIP TYPE CARBON RESISTOR	RN72K1J-472JE	1	435034724R1	NSP
R8306	CHIP TYPE CARBON RESISTOR	RN72K1J-562JE	1	435035624R1	NSP
R8307	CHIP TYPE CARBON RESISTOR	RN72K1J-472JE	1	435034724R1	NSP
R8308	CHIP TYPE CARBON RESISTOR	RN72K1J-562JE	1	435035624R1	NSP
R8312	CHIP TYPE CARBON RESISTOR	RN72K1J-100JE	1	435031004R1	NSP
R8318	CHIP RESISTOR NETWORK	MNR04MRAPJ222	1	43464722204R2	N NSP
R8318or	CHIP RESISTOR NETWORK	YCN104-222-JK	(1)	43464C22204R1	NSP
R8319	CHIP TYPE CARBON RESISTOR	RN72K1J-100JE	1	435031004R1	NSP
R8320	CHIP TYPE CARBON RESISTOR	RN72K1J-100JE	1	435031004R1	NSP
R8321	CHIP TYPE CARBON RESISTOR	RN72K1J-330JE	1	435033304R1	NSP
R8322	CHIP TYPE CARBON RESISTOR	RN72K1J-330JE	1	435033304R1	NSP
R8323	CHIP TYPE CARBON RESISTOR	RN72K1J-330JE	1	435033304R1	NSP
R8324	CHIP TYPE CARBON RESISTOR	RN72K1J-330JE	1	435033304R1	NSP
R8334	CHIP TYPE CARBON RESISTOR	RN72K1J-000JE	1	435030004R1	NSP
R8335	CHIP TYPE CARBON RESISTOR	RN72K1J-330JE	1	435033304R1	NSP
R8336	CHIP TYPE CARBON RESISTOR	RN72K1J-330JE	1	435033304R1	NSP
R8338	CHIP TYPE CARBON RESISTOR	RN72K1J-330JE	1	435033304R1	NSP
R8339	CHIP TYPE CARBON RESISTOR	RN72K1J-330JE	1	435033304R1	NSP
R8342	CHIP RESISTOR NETWORK	MNR04MRAPJ220	1	43464722004R2	N NSP
R8342or	CHIP RESISTOR NETWORK	YCN104-220-JK	(1)	43464C22004R1	NSP
R8343	CHIP RESISTOR NETWORK	MNR04MRAPJ220	1	43464722004R2	N NSP
R8343or	CHIP RESISTOR NETWORK	YCN104-220-JK	(1)	43464C22004R1	NSP
R8346	CHIP TYPE CARBON RESISTOR	RN72K1J-220JE	1	435032204R1	NSP
R8350	CHIP TYPE CARBON RESISTOR	RN72K1J-100JE	1	435031004R1	NSP
R8354	CHIP TYPE CARBON RESISTOR	RN72K1J-100JE	1	435031004R1	NSP
R8355	CHIP TYPE CARBON RESISTOR	RN72K1J-100JE	1	435031004R1	NSP
R8357	CHIP TYPE CARBON RESISTOR	RN72K1J-101JE	1	435031014R1	NSP
R8358	CHIP TYPE CARBON RESISTOR	RN72K1J-102JE	1	435031024R1	NSP
R8359	CHIP TYPE CARBON RESISTOR	RN72K1J-124JE	1	435031244R1	NSP
R8363	CHIP RESISTOR NETWORK	MNR04MRAPJ330	1	43464733004R2	N NSP
R8363or	CHIP RESISTOR NETWORK	YCN104-330-JK	(1)	43464C33004R1	NSP
R8365	CHIP TYPE CARBON RESISTOR	RN72K1J-103JE	1	435031034R1	NSP
R8372	CHIP TYPE CARBON RESISTOR	RN72K1J-100JE	1	435031004R1	NSP

R8373	CHIP TYPE CARBON RESISTOR	RN72K1J-100JE	1	435031004R1	NSP
R8374	CHIP TYPE CARBON RESISTOR	RN72K1J-100JE	1	435031004R1	NSP
R8375	CHIP TYPE CARBON RESISTOR	RN72K1J-100JE	1	435031004R1	NSP
R8376	CHIP TYPE CARBON RESISTOR	RN72K1J-100JE	1	435031004R1	NSP
R8377	CHIP TYPE CARBON RESISTOR	RN72K1J-100JE	1	435031004R1	NSP
R8378	CHIP TYPE CARBON RESISTOR	RN72K1J-100JE	1	435031004R1	NSP
R8379	CHIP TYPE CARBON RESISTOR	RN72K1J-562JE	1	435035624R1	NSP
R8380	CHIP TYPE CARBON RESISTOR	RN72K1J-562JE	1	435035624R1	NSP
R8382	CHIP TYPE CARBON RESISTOR	RN72K1J-000JE	1	435030004R1	NSP
R8383	CHIP TYPE CARBON RESISTOR	RN72K1J-000JE	1	435030004R1	NSP
R8384	CHIP TYPE CARBON RESISTOR	RN72K1J-000JE	1	435030004R1	NSP
R8385	CHIP TYPE CARBON RESISTOR	RN72K1J-000JE	1	435030004R1	NSP
R8386	CHIP TYPE CARBON RESISTOR	RN72K1J-105JE	1	435031054R1	NSP
R8400	CHIP RESISTOR NETWORK	MNR04MRAPJ103	1	43464710304R2	N NSP
R8400or	CHIP RESISTOR NETWORK	YCN104-103-JK	(1)	43464C10304R1	NSP
R8401	CHIP TYPE CARBON RESISTOR	RN72K1J-103JE	1	435031034R1	NSP
R8402	CHIP RESISTOR NETWORK	MNR04MRAPJ470	1	43464747004R2	N NSP
R8402or	CHIP RESISTOR NETWORK	YCN104-470-JK	(1)	43464C47004R1	NSP
R8403	CHIP TYPE CARBON RESISTOR	RN72K1J-473JE	1	435034734R1	NSP
R8405	CHIP TYPE CARBON RESISTOR	RN72K1J-470JE	1	435034704R1	NSP
R8406	CHIP TYPE CARBON RESISTOR	RN72K1J-101JE	1	435031014R1	NSP
R8407	CHIP TYPE CARBON RESISTOR	RN72K1J-470JE	1	435034704R1	NSP
R8408	CHIP TYPE CARBON RESISTOR	RN72K1J-470JE	1	435034704R1	NSP
R8414	CHIP TYPE CARBON RESISTOR	RN72K1J-470JE	1	435034704R1	NSP
R8415	CHIP TYPE CARBON RESISTOR	RN72K1J-470JE	1	435034704R1	NSP
R8416	CHIP TYPE CARBON RESISTOR	RN72K1J-101JE	1	435031014R1	NSP
R8417	CHIP TYPE CARBON RESISTOR	RN72K1J-105JE	1	435031054R1	NSP
R8418	CHIP TYPE CARBON RESISTOR	RN72K1J-470JE	1	435034704R1	NSP
R8419	CHIP TYPE CARBON RESISTOR	RN72K1J-470JE	1	435034704R1	NSP
R8420	CHIP TYPE CARBON RESISTOR	RN72K1J-470JE	1	435034704R1	NSP
R8421	CHIP TYPE CARBON RESISTOR	RN72K1J-103JE	1	435031034R1	NSP
R8422	CHIP TYPE CARBON RESISTOR	RN72K1J-101JE	1	435031014R1	NSP
R8423	CHIP TYPE CARBON RESISTOR	RN72K1J-332JE	1	435033324R1	NSP
R8424	CHIP TYPE CARBON RESISTOR	RN72K1J-332JE	1	435033324R1	NSP
R8425	CHIP TYPE CARBON RESISTOR	RN72K1J-470JE	1	435034704R1	NSP
R8426	CHIP TYPE CARBON RESISTOR	RN72K1J-470JE	1	435034704R1	NSP
R8427	CHIP TYPE CARBON RESISTOR	RN72K1J-100JE	1	435031004R1	NSP
R8429	CHIP TYPE CARBON RESISTOR	RN72K1J-470JE	1	435034704R1	NSP
R8430	CHIP TYPE CARBON RESISTOR	RN72K1J-470JE	1	435034704R1	NSP
R8431	CHIP TYPE CARBON RESISTOR	RN72K1J-470JE	1	435034704R1	NSP
R8432	CHIP TYPE CARBON RESISTOR	RN72K1J-470JE	1	435034704R1	NSP
R8437	CHIP TYPE CARBON RESISTOR	RN72K1J-473JE	1	435034734R1	NSP
R8438	CHIP TYPE CARBON RESISTOR	RN72K1J-220JE	1	435032204R1	NSP
R8439	CHIP TYPE CARBON RESISTOR	RN72K1J-220JE	1	435032204R1	NSP
R8440	CHIP TYPE CARBON RESISTOR	RN72K1J-220JE	1	435032204R1	NSP
R8441	CHIP TYPE CARBON RESISTOR	RN72K1J-220JE	1	435032204R1	NSP
R8442	CHIP TYPE CARBON RESISTOR	RN72K1J-220JE	1	435032204R1	NSP
R8443	CHIP TYPE CARBON RESISTOR	RN72K1J-220JE	1	435032204R1	NSP
R8444	CHIP TYPE CARBON RESISTOR	RN72K1J-101JE	1	435031014R1	NSP
R8445	CHIP TYPE CARBON RESISTOR	RN72K1J-101JE	1	435031014R1	NSP
R8446	CHIP TYPE CARBON RESISTOR	RN72K1J-472JE	1	435034724R1	NSP
R8447	CHIP TYPE CARBON RESISTOR	RN72K1J-102JE	1	435031024R1	NSP
R8448	CHIP TYPE CARBON RESISTOR	RN72K1J-103JE	1	435031034R1	NSP
R8449	CHIP TYPE CARBON RESISTOR	RN72K1J-182JE	1	435031824R1	NSP
R8450	CHIP TYPE CARBON RESISTOR	RN72K1J-182JE	1	435031824R1	NSP

R8451	CHIP TYPE CARBON RESISTOR	RN72K1J-000JE	1	435030004R1	NSP
R8452	CHIP TYPE CARBON RESISTOR	RN72K1J-103FE	1	435031032R1	NSP
R8453	CHIP TYPE CARBON RESISTOR	RN72K1J-223FE	1	435032232R1	NSP
R8458	CHIP TYPE CARBON RESISTOR	RN72K1J-100JE	1	435031004R1	NSP
R8459	CHIP TYPE CARBON RESISTOR	RN72K1J-560JE	1	435035604R1	NSP
R8461	CHIP TYPE CARBON RESISTOR	RN72K1J-560JE	1	435035604R1	NSP
R8462	CHIP TYPE CARBON RESISTOR	RN72K1J-473JE	1	435034734R1	NSP
R8464	CHIP RESISTOR NETWORK	MNR04MRAPJ470	1	43464747004R2	N NSP
R8464or	CHIP RESISTOR NETWORK	YCN104-470-JK	(1)	43464C47004R1	NSP
R8465	CHIP RESISTOR NETWORK	MNR04MRAPJ101	1	43464710104R2	N NSP
R8465or	CHIP RESISTOR NETWORK	YCN104-101-JK	(1)	43464C10104R1	NSP
R8466	CHIP RESISTOR NETWORK	MNR04MRAPJ220	1	43464722004R2	N NSP
R8466or	CHIP RESISTOR NETWORK	YCN104-220-JK	(1)	43464C22004R1	NSP
R8467	CHIP RESISTOR NETWORK	MNR04MRAPJ220	1	43464722004R2	N NSP
R8467or	CHIP RESISTOR NETWORK	YCN104-220-JK	(1)	43464C22004R1	NSP
R8468	CHIP RESISTOR NETWORK	MNR04MRAPJ220	1	43464722004R2	N NSP
R8468or	CHIP RESISTOR NETWORK	YCN104-220-JK	(1)	43464C22004R1	NSP
R8469	CHIP RESISTOR NETWORK	MNR04MRAPJ220	1	43464722004R2	N NSP
R8469or	CHIP RESISTOR NETWORK	YCN104-220-JK	(1)	43464C22004R1	NSP
R8471	CHIP TYPE CARBON RESISTOR	RN72K1J-220JE	1	435032204R1	NSP
R8472	CHIP TYPE CARBON RESISTOR	RN72K1J-220JE	1	435032204R1	NSP
R8473	CHIP TYPE CARBON RESISTOR	RN72K1J-220JE	1	435032204R1	NSP
R8474	CHIP TYPE CARBON RESISTOR	RN72K1J-220JE	1	435032204R1	NSP
R8475	CHIP TYPE CARBON RESISTOR	RN72K1J-220JE	1	435032204R1	NSP
R8476	CHIP TYPE CARBON RESISTOR	RN72K1J-000JE	1	435030004R1	NSP
R8477	CHIP TYPE CERAMIC CAPACITOR	CK725B1H-102K0	1	332031025R1	NSP
R8478	CHIP TYPE CERAMIC CAPACITOR	CK725B1H-102K0	1	332031025R1	NSP
R8479	CHIP TYPE CERAMIC CAPACITOR	CK725B1H-102K0	1	332031025R1	NSP
R8480	CHIP TYPE CERAMIC CAPACITOR	CK725B1H-102K0	1	332031025R1	NSP
R8600	CHIP TYPE CARBON RESISTOR	RN72K1J-000JE	1	435030004R1	NSP
R8613	CHIP TYPE CARBON RESISTOR	RN72K1J-473JE	1	435034734R1	NSP
R8614	CHIP TYPE CARBON RESISTOR	RN72K1J-473JE	1	435034734R1	NSP
R8615	CHIP TYPE CARBON RESISTOR	RN72K1J-100JE	1	435031004R1	NSP
R8623	CHIP TYPE CARBON RESISTOR	RN72K1J-473JE	1	435034734R1	NSP
R8624	CHIP TYPE CARBON RESISTOR	RN72K1J-473JE	1	435034734R1	NSP
R8625	CHIP TYPE CARBON RESISTOR	RN72K1J-100JE	1	435031004R1	NSP
R8633	CHIP TYPE CARBON RESISTOR	RN72K1J-473JE	1	435034734R1	NSP
R8634	CHIP TYPE CARBON RESISTOR	RN72K1J-473JE	1	435034734R1	NSP
R8635	CHIP TYPE CARBON RESISTOR	RN72K1J-100JE	1	435031004R1	NSP
R8645	CHIP TYPE CARBON RESISTOR	RN72K1J-100JE	1	435031004R1	NSP
R8663	CHIP TYPE CARBON RESISTOR	RN72K1J-473JE	1	435034734R1	NSP
R8664	CHIP TYPE CARBON RESISTOR	RN72K1J-473JE	1	435034734R1	NSP
R8665	CHIP TYPE CARBON RESISTOR	RN72K1J-100JE	1	435031004R1	NSP
R8702	CHIP RESISTOR NETWORK	MNR04MRAPJ221	1	43464722104R2	N NSP
R8702or	CHIP RESISTOR NETWORK	YCN104-221-JK	(1)	43464C22104R1	NSP
R8703	CHIP TYPE CARBON RESISTOR	RN72K1J-103JE	1	435031034R1	NSP
R8704	CHIP RESISTOR NETWORK	MNR04MRAPJ103	1	43464710304R2	N NSP
R8704or	CHIP RESISTOR NETWORK	YCN104-103-JK	(1)	43464C10304R1	NSP
R8705	CHIP TYPE CARBON RESISTOR	RN72K1J-473JE	1	435034734R1	NSP
R8707	CHIP RESISTOR NETWORK	MNR04MRAPJ103	1	43464710304R2	N NSP
R8707or	CHIP RESISTOR NETWORK	YCN104-103-JK	(1)	43464C10304R1	NSP
R8709	CHIP TYPE CARBON RESISTOR	RN72K1J-470JE	1	435034704R1	NSP
R8710	CHIP TYPE CARBON RESISTOR	RN72K1J-102JE	1	435031024R1	NSP
R8711	CHIP TYPE CARBON RESISTOR	RN72K1J-103JE	1	435031034R1	NSP
R8712	CHIP TYPE CARBON RESISTOR	RN72K1J-470JE	1	435034704R1	NSP

R8713	CHIP TYPE CARBON RESISTOR	RN72K1J-101JE	1	435031014R1	NSP
R8716	CHIP TYPE CARBON RESISTOR	RN72K1J-332JE	1	435033324R1	NSP
R8717	CHIP TYPE CARBON RESISTOR	RN72K1J-332JE	1	435033324R1	NSP
R8718	CHIP TYPE CARBON RESISTOR	RN72K1J-222JE	1	435032224R1	NSP
R8719	CHIP TYPE CARBON RESISTOR	RN72K1J-222JE	1	435032224R1	NSP
R8720	CHIP TYPE CARBON RESISTOR	RN72K1J-103JE	1	435031034R1	NSP
R8721	CHIP RESISTOR NETWORK	MNR04MRAPJ470	1	43464747004R2	N NSP
R8721or	CHIP RESISTOR NETWORK	YCN104-470-JK	(1)	43464C47004R1	NSP
R8723	CHIP TYPE CARBON RESISTOR	RN72K1J-472JE	1	435034724R1	NSP
R8724	CHIP TYPE CARBON RESISTOR	RN72K1J-473JE	1	435034734R1	NSP
R8727	CHIP TYPE CARBON RESISTOR	RN72K1J-221JE	1	435032214R1	NSP
R8728	CHIP TYPE CARBON RESISTOR	RN72K1J-103JE	1	435031034R1	NSP
R8729	CHIP TYPE CARBON RESISTOR	RN72K1J-221JE	1	435032214R1	NSP
R8730	CHIP TYPE CARBON RESISTOR	RN72K1J-470JE	1	435034704R1	NSP
R8731	CHIP RESISTOR NETWORK	MNR04MRAPJ103	1	43464710304R2	N NSP
R8731or	CHIP RESISTOR NETWORK	YCN104-103-JK	(1)	43464C10304R1	NSP
R8732	CHIP TYPE CARBON RESISTOR	RN72K1J-221JE	1	435032214R1	NSP
R8733	CHIP TYPE CARBON RESISTOR	RN72K1J-105JE	1	435031054R1	NSP
R8734	CHIP TYPE CARBON RESISTOR	RN72K1J-470JE	1	435034704R1	NSP
R8735	CHIP TYPE CARBON RESISTOR	RN72K1J-221JE	1	435032214R1	NSP
R8736	CHIP TYPE CARBON RESISTOR	RN72K1J-102JE	1	435031024R1	NSP
R8737	CHIP TYPE CARBON RESISTOR	RN72K1J-472JE	1	435034724R1	NSP
R8738	CHIP TYPE CARBON RESISTOR	RN72K1J-103JE	1	435031034R1	NSP
R8739	CHIP TYPE CARBON RESISTOR	RN72K1J-102JE	1	435031024R1	NSP
R8740	CHIP TYPE CARBON RESISTOR	RN72K1J-103JE	1	435031034R1	NSP
R8741	CHIP TYPE CARBON RESISTOR	RN72K1J-102JE	1	435031024R1	NSP
R8742	CHIP TYPE CARBON RESISTOR	RN72K1J-103JE	1	435031034R1	NSP
R8743	CHIP TYPE CARBON RESISTOR	RN72K1J-103JE	1	435031034R1	NSP
R8744	CHIP TYPE CARBON RESISTOR	RN72K1J-470JE	1	435034704R1	NSP
R8745	CHIP TYPE CARBON RESISTOR	RN72K1J-103JE	1	435031034R1	NSP
R8746	CHIP TYPE CARBON RESISTOR	RN72K1J-470JE	1	435034704R1	NSP
R8748	CHIP TYPE CARBON RESISTOR	RN72K1J-470JE	1	435034704R1	NSP
R8750	CHIP TYPE CARBON RESISTOR	RN72K1J-470JE	1	435034704R1	NSP
R8752	CHIP RESISTOR NETWORK	MNR04MRAPJ101	1	43464710104R2	N NSP
R8752or	CHIP RESISTOR NETWORK	YCN104-101-JK	(1)	43464C10104R1	NSP
R8753	CHIP RESISTOR NETWORK	MNR04MRAPJ470	1	43464747004R2	N NSP
R8753or	CHIP RESISTOR NETWORK	YCN104-470-JK	(1)	43464C47004R1	NSP
R8754	CHIP TYPE CARBON RESISTOR	RN72K1J-470JE	1	435034704R1	NSP
R8755	CHIP TYPE CARBON RESISTOR	RN72K1J-103JE	1	435031034R1	NSP
R8756	CHIP TYPE CARBON RESISTOR	RN72K1J-103JE	1	435031034R1	NSP
R8757	CHIP RESISTOR NETWORK	MNR04MRAPJ101	1	43464710104R2	N NSP
R8757or	CHIP RESISTOR NETWORK	YCN104-101-JK	(1)	43464C10104R1	NSP
R8758	CHIP TYPE CARBON RESISTOR	RN72K1J-103JE	1	435031034R1	NSP
R8790	CHIP TYPE CARBON RESISTOR	RN72K1J-220JE	1	435032204R1	NSP
R8791	CHIP TYPE CARBON RESISTOR	RN72K1J-220JE	1	435032204R1	NSP
R8900	CHIP TYPE CARBON RESISTOR	RN72K1J-472JE	1	435034724R1	NSP
R8901	CHIP TYPE CARBON RESISTOR	RN72K1J-102JE	1	435031024R1	NSP
R8904	CHIP TYPE CARBON RESISTOR	RN72K1J-102JE	1	435031024R1	NSP
R8922	CHIP TYPE CARBON RESISTOR	RN72K1J-473JE	1	435034734R1	NSP
R8923	CHIP TYPE CARBON RESISTOR	RN72K1J-332JE	1	435033324R1	NSP
R8924	CHIP TYPE CARBON RESISTOR	RN72K1J-682FE	1	435036822R1	NSP
R8925	CHIP TYPE CARBON RESISTOR	RN72K1J-332FE	1	435033322R1	NSP
R8926	CHIP TYPE CARBON RESISTOR	RN72K1J-103FE	1	435031032R1	NSP
R8932	CHIP TYPE CARBON RESISTOR	RN72K1J-473JE	1	435034734R1	NSP
R8933	CHIP TYPE CARBON RESISTOR	RN72K1J-332JE	1	435033324R1	NSP

R8934	CHIP TYPE CARBON RESISTOR	RN72K1J-272FE	1	435032722R1	NSP
R8935	CHIP TYPE CARBON RESISTOR	RN72K1J-222FE	1	435032222R1	NSP
R8936	CHIP TYPE CARBON RESISTOR	RN72K1J-103FE	1	435031032R1	NSP
R8939	CHIP TYPE CARBON RESISTOR	RN72K1J-102JE	1	435031024R1	NSP
R8943	CHIP TYPE CARBON RESISTOR	RN72K1J-472JE	1	435034724R1	NSP
R8944	CHIP TYPE CARBON RESISTOR	RN72K1J-103FE	1	435031032R1	NSP
R8946	CHIP TYPE CARBON RESISTOR	RN72K1J-103FE	1	435031032R1	NSP
R8949	CHIP TYPE CARBON RESISTOR	RN72K1J-104JE	1	435031044R1	NSP
R8952	CHIP TYPE CARBON RESISTOR	RN72K1J-473JE	1	435034734R1	NSP
R8953	CHIP TYPE CARBON RESISTOR	RN72K1J-682JE	1	435036824R1	NSP
R8954	CHIP TYPE CARBON RESISTOR	RN72K1J-333FE	1	435033332R1	NSP
R8955	CHIP TYPE CARBON RESISTOR	RN72K1J-124FE	1	435031242R1	N NSP
R8956	CHIP TYPE CARBON RESISTOR	RN72K1J-103FE	1	435031032R1	NSP
R8958	CHIP TYPE CARBON RESISTOR	RN72K1J-473JE	1	435034734R1	NSP
R8962	CHIP TYPE CARBON RESISTOR	RN72K1J-473JE	1	435034734R1	NSP
R8964	CHIP TYPE CARBON RESISTOR	RN72K1J-563FE	1	435035632R1	NSP
R8965	CHIP TYPE CARBON RESISTOR	RN72K1J-274JE	1	435032744R1	NSP
R8966	CHIP TYPE CARBON RESISTOR	RN72K1J-103FE	1	435031032R1	NSP
R8982	CHIP TYPE CARBON RESISTOR	RN72K1J-104JE	1	435031044R1	NSP
R8983	CHIP TYPE CARBON RESISTOR	RN72K1J-473JE	1	435034734R1	NSP
R8984	CHIP TYPE CARBON RESISTOR	RN72K1J-103JE	1	435031034R1	NSP
R8985	CHIP TYPE CARBON RESISTOR	RN72K1J-473JE	1	435034734R1	NSP
R8987	CHIP TYPE CARBON RESISTOR	RN72K1J-000JE	1	435030004R1	NSP
R8988	CHIP TYPE CARBON RESISTOR	RN72K1J-000JE	1	435030004R1	NSP
R8989	CHIP TYPE CARBON RESISTOR	RN72K1J-103JE	1	435031034R1	NSP
R8990	CHIP TYPE CARBON RESISTOR	RN72K1J-102JE	1	435031024R1	NSP
[Switches, Terminals, Wires]					
P0004A	PRINTED WIRING BOARD	BCPRC-2034	{1}	25142034	N NSP
P040	PRINTED WIRING BOARD	BCPRC-2034	1	25142034A	N NSP
P2800B	SOCKET	IMSA-9618S-23A	1	25053348R2	NSP
P2802B	PLUG	NPLG-5P918	1	25055965R2	NSP
P3201	SOCKET	NSCT-9P2472	1	25052575R2	NSP
P3601	SOCKET	UJA01SB4090-72R	1	25053533R2	N NSP
P3651	SOCKET	MP04B1S2AM0-07T	1	25053617R3	N NSP
P3654	SOCKET	APCI0085-P002A	1	25053616R2	N NSP
P3658	TERMINAL	APCI0213-K001A	1	25060548R2	N NSP
P6800B	PLUG	NPLG-5P918	1	25055965R2	NSP
P7001A	SOCKET	31FMN-SMT-A-TF	1	25052848R2	N NSP
P7501	SOCKET	NSCT-9P2472	1	25052575R2	NSP
P8001	SOCKET	51U019S-3HFDN-BD-SM	1	25053549R3	N NSP
P8001or	SOCKET	TCX3423-311387	(1)	25060513R3	NSP
P8001or	SOCKET	HDMI(47266-4101)	(1)	25053389R3	NSP
P8002B	PLUG	IMSA-9850B-30Y	1	25056329R2	N NSP
P8003B	PLUG	IMSA-9850B-30Y	1	25056329R2	N NSP
P8611	SOCKET	51U019S-3HFDN-BD-SM	1	25053549R3	N NSP
P8611or	SOCKET	TCX3423-311387	(1)	25060513R3	NSP
P8611or	SOCKET	HDMI(47266-4101)	(1)	25053389R3	NSP
P8621	SOCKET	51U019S-3HFDN-BD-SM	1	25053549R3	N NSP
P8621or	SOCKET	TCX3423-311387	(1)	25060513R3	NSP
P8621or	SOCKET	HDMI(47266-4101)	(1)	25053389R3	NSP
P8631	SOCKET	51U019S-3HFDN-BD-SM	1	25053549R3	N NSP
P8631or	SOCKET	TCX3423-311387	(1)	25060513R3	NSP
P8631or	SOCKET	HDMI(47266-4101)	(1)	25053389R3	NSP
P8641	SOCKET	51U019S-3HFDN-BD-SM	1	25053549R3	N NSP
P8641or	SOCKET	TCX3423-311387	(1)	25060513R3	NSP

P8641or	SOCKET	HDMI(47266-4101)	(1)	25053389R3	NSP
P8651	SOCKET	51U019S-3HFDN-BD-SM	1	25053549R3	N NSP
P8651or	SOCKET	TCX3423-311387	(1)	25060513R3	NSP
P8651or	SOCKET	HDMI(47266-4101)	(1)	25053389R3	NSP
P8661	SOCKET	51U019S-3HFDN-BD-SM	1	25053549R3	N NSP
P8661or	SOCKET	TCX3423-311387	(1)	25060513R3	NSP
P8661or	SOCKET	HDMI(47266-4101)	(1)	25053389R3	NSP
[Frontend, Units]					
BAPRC-2034 Processing circuit pc board AS		BAPRC-2034-1A	1	1B5142034-1A-C	Child

BATRM-2023-1A**<Note>**

Parts marked by "NSP" are generally unavailable because they are not in our Master Spare Parts List.

<Notes>

█ : NSP

NOTE : THE COMPONENTS IDENTIFIED BY THE MARK ! ARE CRITICAL FOR RISK OF FIRE AND ELECTRIC SHOCK. REPLACE ONLY WITH PART

REF. NO.	PART NAME	DESCRIPTION	Q'TY	PART NO. (SN)	REMARKS
[Semi-conductors]					
D2000	DIODE	G10XB80-02-54A-T	1	22380378	
D2000A	HEAT SINK	RAD-083	1	27160271	NSP
D2000B	SCREW	3P+10FN(3BC)	1	82143010GR	NSP
D2001	CHIP TYPE DIODE	DA2J10100	1	223303R2	NSP
D2001or	CHIP TYPE DIODE	1SS352	(1)	223234R2	NSP
D2002	CHIP TYPE DIODE	DA2J10100	1	223303R2	NSP
D2002or	CHIP TYPE DIODE	1SS352	(1)	223234R2	NSP
D2003	ZENER DIODE	DZ2J062M0L	1	224760620R2	NSP
D2003or	ZENER DIODE	UDZS6.2B	(1)	224550620R2	NSP
D2004	DIODE	RBR3MM30ATR	1	22380401R2	N NSP
D2005	DIODE	RBR3MM30ATR	1	22380401R2	N NSP
D6501	CHIP TYPE DIODE	DA2J10100	1	223303R2	NSP
D6501or	CHIP TYPE DIODE	1SS352	(1)	223234R2	NSP
D6503	CHIP TYPE DIODE	DA2J10100	1	223303R2	NSP
D6503or	CHIP TYPE DIODE	1SS352	(1)	223234R2	NSP
D6507	CHIP TYPE DIODE	DA2J10100	1	223303R2	NSP
D6507or	CHIP TYPE DIODE	1SS352	(1)	223234R2	NSP
D6509	CHIP TYPE DIODE	DA2J10100	1	223303R2	NSP
D6509or	CHIP TYPE DIODE	1SS352	(1)	223234R2	NSP
Q2100	HYBRID IC	74VHC4053AFT	1	22274053ER2TO	N NSP
Q2101	HYBRID IC	74VHC4051AFT	1	22274051ER2TO	N NSP
Q2102	TRANSISTOR	2SA1162-GR	1	2214375R2	NSP
Q2103	TRANSISTOR	2SA1162-GR	1	2214375R2	NSP
Q2104	TRANSISTOR	2SA1162-GR	1	2214375R2	NSP
Q6501	TRANSISTOR	KRC105S	1	2217290R2	NSP
Q6501or	TRANSISTOR	RN1405	(1)	2214500R2	NSP
Q6503	TRANSISTOR	KRC105S	1	2217290R2	NSP
Q6503or	TRANSISTOR	RN1405	(1)	2214500R2	NSP
Q6507	TRANSISTOR	KRC105S	1	2217290R2	NSP
Q6507or	TRANSISTOR	RN1405	(1)	2214500R2	NSP
Q6509	TRANSISTOR	KRC105S	1	2217290R2	NSP
Q6509or	TRANSISTOR	RN1405	(1)	2214500R2	NSP
[Transformers, Coils]					
L2100	CHOKE COIL	LBC2518T470M	1	231364M470R2	NSP
[Capacitors]					
C2000	FILM C	C281H334J20A21A	1	376823344T	N NSP
C2001	JAMICON TYPE ELECTROLYTIC CAPACIT	CE04W50V-4.7M	1	398580477T	
C2001or	VR TYPE ELECTROLYTIC CAPACITOR	CE04W50V-4.7M(VR)	(1)	394680477T	
C2002	ELECTROLYTIC CAPACITOR	CE69W25V-10000M	1	3504512	N
C2002or	ELECTROLYTIC CAPACITOR	CE69W25V-10000M	(1)	3504502	
C2100	CHIP TYPE CERAMIC CAPACITOR	CK725B1H-103K1	1	332101035R1	NSP
C2101	CHIP TYPE CERAMIC CAPACITOR	CK725B1H-103K1	1	332101035R1	NSP
C2102	JAMICON TYPE ELECTROLYTIC CAPACIT	CE04W50V-2.2M	1	398580227T	
C2102or	VR TYPE ELECTROLYTIC CAPACITOR	CE04W50V-2.2M(VR)	(1)	394680227T	

C2103	JAMICON TYPE ELECTROLYTIC CAPACIT	CE04W50V-2.2M	1	398580227T	
C2103or	VR TYPE ELECTROLYTIC CAPACITOR	CE04W50V-2.2M(VR)	(1)	394680227T	
C2104	JAMICON TYPE ELECTROLYTIC CAPACIT	CE04W50V-2.2M	1	398580227T	
C2104or	VR TYPE ELECTROLYTIC CAPACITOR	CE04W50V-2.2M(VR)	(1)	394680227T	
C2105	JAMICON TYPE ELECTROLYTIC CAPACIT	CE04W50V-2.2M	1	398580227T	
C2105or	VR TYPE ELECTROLYTIC CAPACITOR	CE04W50V-2.2M(VR)	(1)	394680227T	
C2106	JAMICON TYPE ELECTROLYTIC CAPACIT	CE04W50V-2.2M	1	398580227T	
C2106or	VR TYPE ELECTROLYTIC CAPACITOR	CE04W50V-2.2M(VR)	(1)	394680227T	
C2107	JAMICON TYPE ELECTROLYTIC CAPACIT	CE04W50V-2.2M	1	398580227T	
C2107or	VR TYPE ELECTROLYTIC CAPACITOR	CE04W50V-2.2M(VR)	(1)	394680227T	
C2108	JAMICON TYPE ELECTROLYTIC CAPACIT	CE04W50V-2.2M	1	398580227T	
C2108or	VR TYPE ELECTROLYTIC CAPACITOR	CE04W50V-2.2M(VR)	(1)	394680227T	
C2109	JAMICON TYPE ELECTROLYTIC CAPACIT	CE04W50V-2.2M	1	398580227T	
C2109or	VR TYPE ELECTROLYTIC CAPACITOR	CE04W50V-2.2M(VR)	(1)	394680227T	
C2110	CHIP TYPE CERAMIC CAPACITOR	CK725F1E-104Z1	1	332161040R1	NSP
C2111	CHIP TYPE CERAMIC CAPACITOR	CK725F1E-104Z1	1	332161040R1	NSP
C2113	CHIP TYPE CERAMIC CAPACITOR	CK725B1H-103K1	1	332101035R1	NSP
C2114	UTSP TYPE ELECTROLYTIC CAPACITOR	CE04W10V-220M(UTSP)	1	397532217AT	N
C2117	CHIP TYPE CERAMIC CAPACITOR	CK725B1H-103K1	1	332101035R1	NSP
C2119	CHIP TYPE CERAMIC CAPACITOR	CK725B1H-103K1	1	332101035R1	NSP
C6501	CHIP TYPE CERAMIC CAPACITOR	CK725F1H-104Z1	1	332151040R1	NSP
C6503	CHIP TYPE CERAMIC CAPACITOR	CK725F1H-104Z1	1	332151040R1	NSP
C6505	CHIP TYPE CERAMIC CAPACITOR	CK725F1H-104Z1	1	332151040R1	NSP
C6507	CHIP TYPE CERAMIC CAPACITOR	CK725F1H-104Z1	1	332151040R1	NSP
C6509	CHIP TYPE CERAMIC CAPACITOR	CK725F1H-104Z1	1	332151040R1	NSP
C6520	UMXR TYPE PLASTIC FILM CAPACITOR	1JUMXRTF102JE	1	376591024T	N NSP
C6521	UMXR TYPE PLASTIC FILM CAPACITOR	1JUMXRTF102JE	1	376591024T	N NSP
C6522	UMXR TYPE PLASTIC FILM CAPACITOR	1JUMXRTF102JE	1	376591024T	N NSP
C6523	UMXR TYPE PLASTIC FILM CAPACITOR	1JUMXRTF102JE	1	376591024T	N NSP
C6525	UMXR TYPE PLASTIC FILM CAPACITOR	1JUMXRTF102JE	1	376591024T	N NSP
C6526	UMXR TYPE PLASTIC FILM CAPACITOR	1JUMXRTF102JE	1	376591024T	N NSP
C6527	UMXR TYPE PLASTIC FILM CAPACITOR	1JUMXRTF102JE	1	376591024T	N NSP
C6528	UMXR TYPE PLASTIC FILM CAPACITOR	1JUMXRTF102JE	1	376591024T	N NSP
C6529	UMXR TYPE PLASTIC FILM CAPACITOR	1JUMXRTF102JE	1	376591024T	N NSP
[Resistors]					
R2000	CHIP TYPE CARBON RESISTOR	RN72K1J-103JE	1	435031034R1	NSP
R2001	CHIP TYPE CARBON RESISTOR	RN72K1J-103JE	1	435031034R1	NSP
R2100	CHIP TYPE CARBON RESISTOR	RN72K1J-750JE	1	435037504R1	NSP
R2101	CHIP TYPE CARBON RESISTOR	RN72K1J-750JE	1	435037504R1	NSP
R2102	CHIP TYPE CARBON RESISTOR	RN72K1J-750JE	1	435037504R1	NSP
R2103	CHIP TYPE CARBON RESISTOR	RN72K1J-750JE	1	435037504R1	NSP
R2104	CHIP TYPE CARBON RESISTOR	RN72K1J-750JE	1	435037504R1	NSP
R2105	CHIP TYPE CARBON RESISTOR	RN72K1J-750JE	1	435037504R1	NSP
R2106	CHIP TYPE CARBON RESISTOR	RN72K1J-750JE	1	435037504R1	NSP
R2107	CHIP TYPE CARBON RESISTOR	RN72K1J-750JE	1	435037504R1	NSP
R2108	CHIP TYPE CARBON RESISTOR	RN72K1J-103JE	1	435031034R1	NSP
R2109	CHIP TYPE CARBON RESISTOR	RN72K1J-271JE	1	435032714R1	NSP
R2110	CHIP TYPE CARBON RESISTOR	RN72K1J-104JE	1	435031044R1	NSP
R2111	CHIP TYPE CARBON RESISTOR	RN72K1J-103JE	1	435031034R1	NSP
R2112	CHIP TYPE CARBON RESISTOR	RN72K1J-103JE	1	435031034R1	NSP
R2113	CHIP TYPE CARBON RESISTOR	RN72K1J-103JE	1	435031034R1	NSP
R2114	CHIP TYPE CARBON RESISTOR	RN72K1J-103JE	1	435031034R1	NSP
R2120	CHIP TYPE CARBON RESISTOR	RN72K1J-333JE	1	435033334R1	NSP
R2121	CHIP TYPE CARBON RESISTOR	RN72K1J-271JE	1	435032714R1	NSP
R2122	CHIP TYPE CARBON RESISTOR	RN72K1J-104JE	1	435031044R1	NSP

R2124	CHIP TYPE CARBON RESISTOR	RN72K1J-333JE	1	435033334R1	NSP
R2125	CHIP TYPE CARBON RESISTOR	RN72K1J-271JE	1	435032714R1	NSP
R2126	CHIP TYPE CARBON RESISTOR	RN72K1J-104JE	1	435031044R1	NSP
R2128	CHIP TYPE CARBON RESISTOR	RN72K1J-333JE	1	435033334R1	NSP
R6500	CHIP TYPE CARBON RESISTOR	RN72K1J-000JE	1	435030004R1	NSP
[Switches, Terminals, Wires]					
F2000	FUSE	T6.3A-SEUL-T250V	1	252399T	I, N
P0003A	PRINTED WIRING BOARD	BCTRM-2023	{1}	25142023A	N NSP
P0003B	PRINTED WIRING BOARD	BCETC-2024	{1}	25142024	N NSP
P0003C	PRINTED WIRING BOARD	BCETC-2025	{1}	25142025	N NSP
P0003D	PRINTED WIRING BOARD	BCETC-2026	{1}	25142026	N NSP
P0003E	PRINTED WIRING BOARD	BCETC-2027	{1}	25142027	N NSP
P030	PRINTED WIRING BOARD	BCTRM-2023	1	25142023	N NSP
P2000	PLUG	NPLG-3P117	1	25055133	N NSP
P2100	PIN JACK	NPJ-2PDY748	1	25046003	N
P2101	PIN JACK	NPJ-6PDGLRGLR646	1	25045871	
P2800A	SOCKET	NSCT-23P2414	1	25052517	NSP
P2802	WIRE HARNESS ASSEMBLY	NSAS-5P2110	1	2009991299UL	N NSP
P2802A	WIRE HOL	CHD-1.5-5	1	25053536	N NSP
P2802Aor	WIRE HOL	NSCT-5P876	(1)	25051089	NSP
P6400B	PLUG	NPLG-7P121	1	25055137	N NSP
P6401B	PLUG	NPLG-9P123	1	25055139	N NSP
P6501	TERMINAL	NTM-6PDMCR456	1	25060535	N
P6505	TERMINAL	NTM-4PDMNRR414	1	25060486	N
P6507	TERMINAL	NTM-4PDMNRR414	1	25060486	N
P6509	TERMINAL	NTM-4PDMNRR414	1	25060486	N
P7880	WIRE HARNESS ASSEMBLY	NSAS-5P2193	1	2009991382UL	N NSP
P7880C	WIRE HOL	CHD-2.5-5	1	25053541	N NSP
P7880Cor	WIRE HOL	NSCT-5P896	(1)	25051109	NSP
P9011B	PLUG	NPLG-5P133	1	25055149	NSP
RL6501	RELAY	NRL-2P5A-DC24-129	1	25065563A	
RL6501or	RELAY	NRL-2P5A-DC24-193	(1)	25065703	
RL6503	RELAY	NRL-2P5A-DC24-129	1	25065563A	
RL6503or	RELAY	NRL-2P5A-DC24-193	(1)	25065703	
RL6505	RELAY	NRL-2P5A-DC24-129	1	25065563A	
RL6505or	RELAY	NRL-2P5A-DC24-193	(1)	25065703	
RL6507	RELAY	NRL-2P5A-DC24-129	1	25065563A	
RL6507or	RELAY	NRL-2P5A-DC24-193	(1)	25065703	
RL6509	RELAY	NRL-2P5A-DC24-129	1	25065563A	
RL6509or	RELAY	NRL-2P5A-DC24-193	(1)	25065703	
[Frontend, Units]					
BATRM-2023	Terminal circuit pc board AS	BATRM-2023-1A	1	1B5142023-1A-C	Child
BAETC-2024	Et cetra pc board AS	BAETC-2024-1A	1	1B5142024-1A-C	Child
BAETC-2025	Et cetra pc board AS	BAETC-2025-1A	1	1B5142025-1A-C	Child
BAETC-2026	Et cetra pc board AS	BAETC-2026-1A	1	1B5142026-1A-C	Child
BAETC-2027	Et cetra pc board AS	BAETC-2027-1A	1	1B5142027-1A-C	Child