

ONKYO® SERVICE MANUAL

AV RECEIVER MODEL TX-NR727(B)/(S)

North American and Taiwanese models ---> "BLUETOOTH"
European, Australian and Asian models ---> "PURE AUDIO"

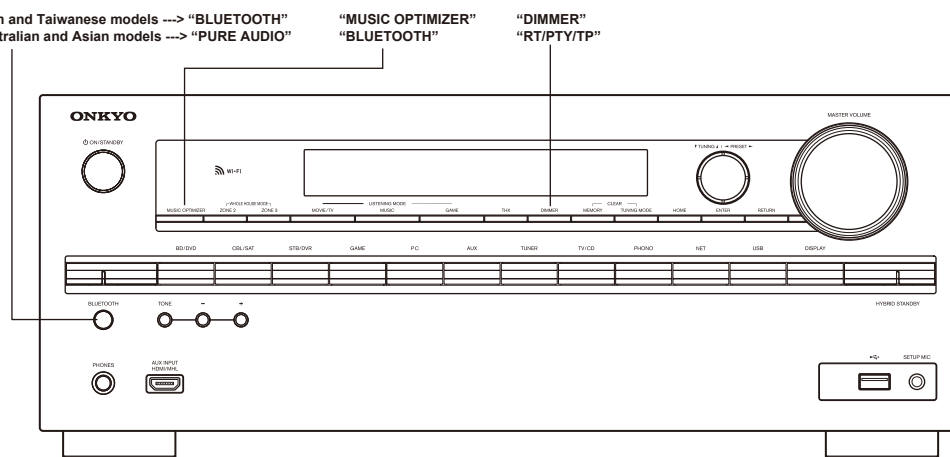

RC-868M

Black and Silver models

B MDC, B MDF	120V AC, 60Hz
B MMQ, B MMR	220-240V AC, 50/60Hz
B MMP, B MMA, S MMP	220-240V AC, 50/60Hz

SAFETY-RELATED COMPONENT WARNING!!

COMPONENTS IDENTIFIED BY MARK  ON THE SCHEMATIC DIAGRAM AND IN THE PARTS LIST ARE CRITICAL FOR RISK OF FIRE AND ELECTRIC SHOCK. REPLACE THESE COMPONENTS WITH ONKYO PARTS WHOSE PART NUMBERS APPEAR AS SHOWN IN THIS MANUAL.

MAKE LEAKAGE-CURRENT OR RESISTANCE MEASUREMENTS TO DETERMINE THAT EXPOSED PARTS ARE ACCEPTABLY INSULATED FROM THE SUPPLY CIRCUIT BEFORE RETURNING THE APPLIANCE TO THE CUSTOMER.

Onkyo Corporation
Service Department

SERVICE PROCEDURE-1

1. Replacing the fuses

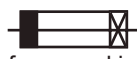
 This symbol located near the fuse indicates that the fuse used is slow operating type, For continued protection against fire hazard, replace with same type fuse, For fuse rating, refer to the marking adjacent to the symbol.

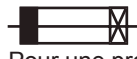
 Ce symbole indique que le fusible utilise est e lent. Pour une protection permanente, n'utiliser que des fusibles de meme type. Ce demier est indique la qu le present symbol est appose.

[Notes]
 <MDC> : 120V,Canadian model
 <MMP> : 220-240V,CE(European) country model
 <MMQ> : 220/230-240V,Hong kong model
 <MMA> : 220-240V,Australian model
 <MMR> : 220/230-240V,Chinese model
 <MDF> : 120V,Taiwanese model

REF NO.	PART NAME	DESCRIPTION	PART NO.	REMARKS
F6401, F6402	FUSE	15A-TUL-250V	252303GR	!
F6401, F6402 or	FUSE	15A-UL/T-314	252197GR	!
F9002	FUSE	10A-UL/T-233	252330GR	!
F9002 or	FUSE	10A-T/UL-ST2	252333GR	!
F9002	FUSE	5A-SE-EAK	252078GR	! <MDC, MDF>
F9002 or	FUSE	5A-SE-TL250V	252278GR	! <MDC, MDF>
F9001	FUSE	1A-SEUL-TL250V	252397T	! <MMA, MMP, MMQ, MMR>
F201	FUSE	4A-SEUL-TL250V	252392T	! <MMA, MMP, MMQ, MMR>

2. Safety check out

(U.S.A. model only)

After correcting the original service problem, perform the following safety check before releasing the unit to the customer.

Leakage current Check

Measure the leakage current to a known earth ground (water pipe or conduct etc.) by connecting a leakage current tester between the earth ground and exposed metal parts of the unit (input/output ground terminals, screw heads or metal overlays etc.).

Plug the power supply cord directly into a 120Vac 60Hz wall socket and turn ON/STANDBY button on.

Any current measured must not exceed 0.5mA.

3. To initialize the unit

Press **ON/STANDBY** button while pressing down **CBL/SAT** button

when the unit is POWER ON, then the FL displays "CLEAR", and turn to STAND-BY. Remove power cord from power line.

4. To check version of each Firmware

a. Push **ON/STANDBY** key while pushing down **DISPLAY** key to display MMPU(Main Microprocessor) version.

e.g.  Version of MMPU displayed only for 3 seconds.

b. In display version, **-(TONE)** key and **+(TONE)** key are pushed to display another F/W version.

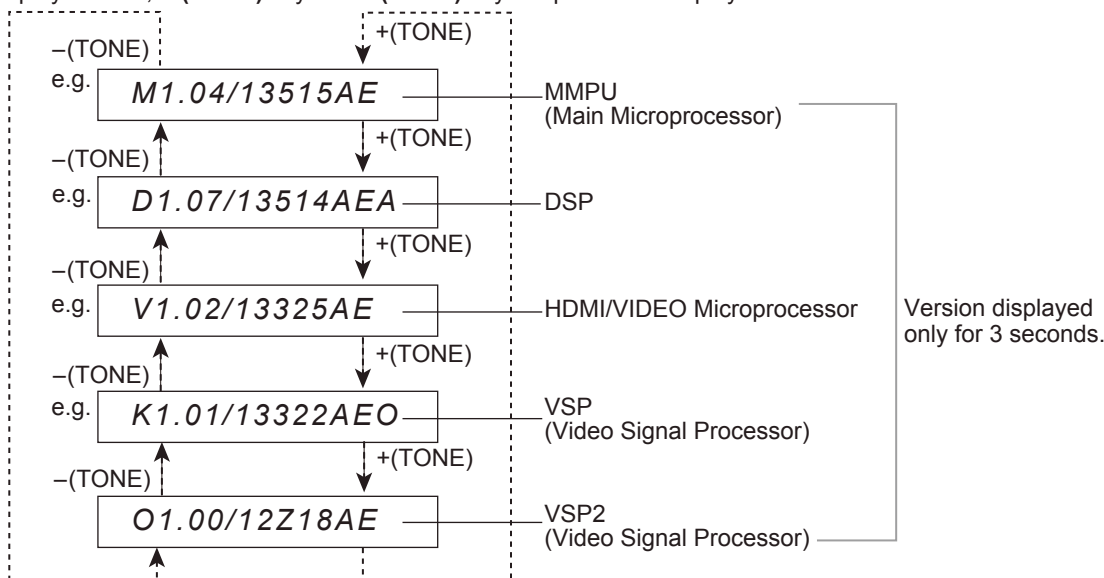

SERVICE PROCEDURE-2

5. Notes on repairs (Power supply board)

Some parts on BAPS-1333 may remain high voltages even after the power cord is disconnected from AC power source. Before starting repair and any other work, please discharge C9002 by connecting resistors between its terminals. See the figure below(recommended resistor spec: 5 k ohms/ 10W)
It is dangerous to touch the "HIGH VOLTAGE PRIMARY" area surrounded by white lines without discharging.

U0063
POWER SUPPLY(PRI) PC BOARD ASS'Y
BAPS-1333

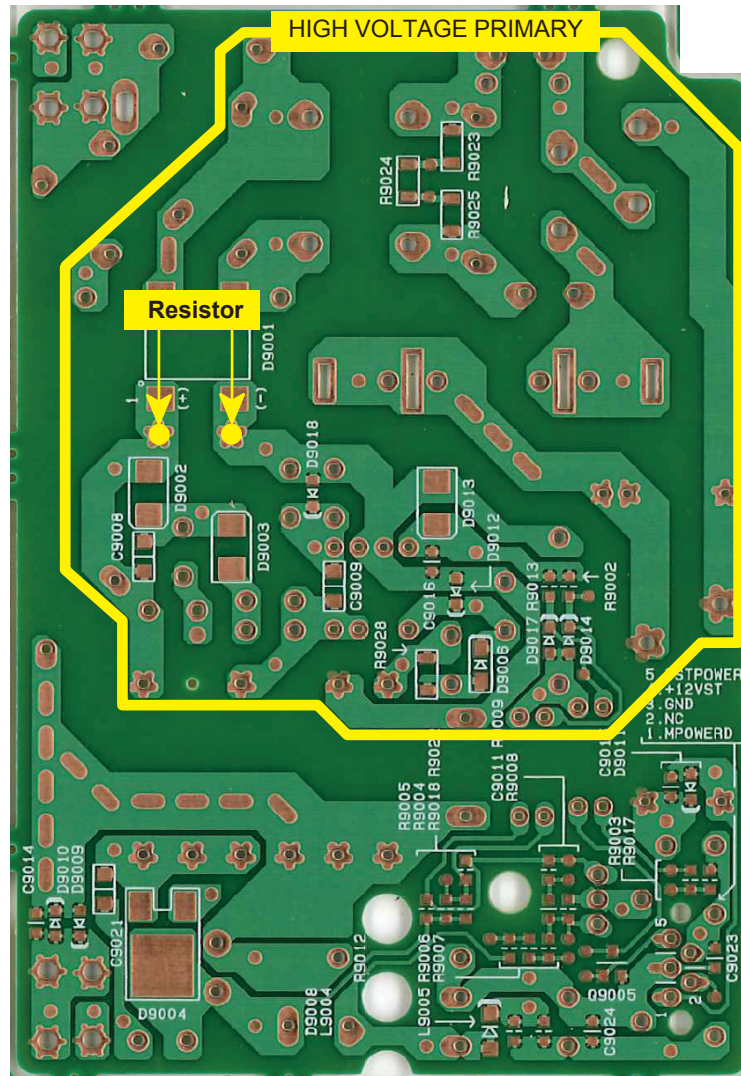

DEBUG MODE-1

AUDIO DEBUG MODE-1/5

The operations of DSP and DIR etc are able to checked by the information displayed on FL in this debug mode. This information will help to analysing digital audio no sound trouble.

To set in Debug mode

1. Press **twice** the **ON/ STANDBY** key while pressing the **DISPLAY** key.

e.g. *M1.01/13204ALN* — The version number of Microprocessor is displayed only for 3 seconds.

2. Press **+** (**TONE**) button while the version number of microprocessor is displayed.

e.g. *D1.02/13202AEA* — The version number of DSP is displayed only for 3 seconds.

3. Press **DISPLAY** button while the version number of DSP is displayed.

e.g. *0A0002: :00* **Step-1**

4. Proceed to the next step by pressing the **DISPLAY** key.

ANA:o:NON:C: **Step-2**



1:ANA 048k048k **Step-3**



2/0.0: 2.0:3/4 **Step-4**



2:o:PCM :PCM **Step-5**



00:x:F:OFF **Step-6**



*SP00F*00F00409* **Step-7**



48 48256STB **Step-8**



L :0000 0000



SW :0000 0000



Exit

AUDIO debug mode

The status of DSP and DIR etc will be displayed.

DEBUG MODE-2

AUDIO DEBUG MODE-2/5

FL Display

Step-1

1	1	2	2	3	3	:	4	4	:	5	5		
---	---	---	---	---	---	---	---	---	---	---	---	--	--

1. st_srd.lmd

01	C_LM_LAST
02	C_LM_PURE
03	C_LM_DIRECT
04	C_LM_STEREO
05	C_LM_MONO
20	C_LM_SURR
50	C_LM_THX_MUSIC
70	C_LM_THX_GAME
90	C_LM_THX_CINEMA
A0	C_LM_THX_U2GAME
A8	C_LM_THX_U2MUSIC
B0	C_LM_THX_U2CINEMA
D0	C_LM_AUDYSSEY
48	C_LM_DTSS
06	C_LM_ORCHESTRA
07	C_LM_UNPLUGGED
08	C_LM_STUDIOMIX
09	C_LM_TVLOGIC
0A	C_LM_ALLCHST
0B	C_LM_FULLMONO
0C	C_LM_TD
F1	C_LM_TESTTONE
F2	C_LM_TESTTHR
F3	C_LM_TESTAUTO

F4	C_LM_ASC
F5	C_LM_FLASH
F6	C_LM_DEBUGMODE
F7	C_LM_FLASH2
F8	C_LM_FLASH3
F9	C_LM_FLASH4
FA	C_LM_FLASH_CHECK
0D	C_LM_RPG
0E	C_LM_ACTION
0F	C_LM_ROCKBAND
10	C_LM_SPORTS

3. st_srd.extdecmd

00	C_EXTDECMD_OFF
01	C_EXTDECMD_10
02	C_EXTDECMD_20
03	C_EXTDECMD_MOVIE
04	C_EXTDECMD_MUSIC
05	C_EXTDECMD_GAME
06	C_EXTDECMD_HEIGHT
07	C_EXTDECMD_WIDE

2. st_srd.extdec

00	C_EXTDEC_OFF
01	C_EXTDEC_20_PLI1
02	C_EXTDEC_20_PLI2
03	C_EXTDEC_20_PLI3
04	C_EXTDEC_20_PLI4
05	C_EXTDEC_51_MTR
06	C_EXTDEC_51_DSC
07	C_EXTDEC_51_NEO6
08	C_EXTDEC_51_EX
09	C_EXTDEC_51_PLI1
0A	C_EXTDEC_51_PLI2
0B	C_EXTDEC_9624
0C	C_EXTDEC_9624_MTR
0E	C_EXTDEC_71MULTI
0F	C_EXTDEC_20_NEURAL
10	C_EXTDEC_51_NEURAL

4. Muting port

D	DIGMUTE port
A	AMUTE port

5. Factor of muting

bit_1	SELMUTE
bit_2	POWMUTE
bit_3	PROTECTMUTE
bit_4	AUDIOOUTMUTE
bit_5	AUDIOMUTE
bit_6	DIRMUTE
bit_7	DACMUTE
bit_8	HDMIMUTE

Step-2

6	6	6	:	7	:	8	8	8	:	9	:	10
---	---	---	---	---	---	---	---	---	---	---	---	----

6. Audio input channel

ANA	Analog
COX	Coaxial
OPT	Optical
HDM	HDMI
ARC	ARC

8. HDMI audio lock

STB	SOUND STATE FIX
TRS	SOUND STATE UNFIX
NON	SOUND STATE NONE

10. RX mute

V	HDMI MUTE
---	-----------

7. DSP decode

o	DSP Detect OK
x	DSP No Detect

9. Display inhibit frag

S	display_inhibit SET
C	display_inhibit CLR

DEBUG MODE-3

AUDIO DEBUG MODE-3/5

Step-3

1	:	11	11	11	11	12	12	12	k	13	13	13	k
---	---	----	----	----	----	----	----	----	---	----	----	----	---

11. Source_format

UNLK	DDR_UNLOCK
ANA	DDR_ANALOG
PCM	DDR_PCM
AC3	DDR_AC3
DTS	DDR_DTS
MPEG	DDR_MPEG
DATA	DDR_DATA
UNKW	DDR_UNKNOWN
NORD	DDR_NOT_READY
NPCM	DDR_NOT_PCM
FS96	DDR_FS96
NODT	DDR_NOT_DETECT

DTSC	DDR_DTSCD
AAC	DDR_AAC
MPCM	DDR_MCHPCM
MCH	DDR_MCH
TRUE	DDR_TRUE
MSTR	DDR_MSTR
DSD	DDR_DSD
PLUS	DDR_DDPLUS
EXPR	DDR_DTSEXP
DTSH	DDR_DTSHD

12. st_srd.fs

???	unknown
008	8kHz
011	11kHz
012	12kHz
016	16kHz
022	22kHz
024	24kHz
032	32kHz
044	44.1kHz
048	48kHz
064	64kHz
088	88.2kHz
096	96kHz
176	176.4kHz
192	192kHz

13. st_hd_display.fs

???	unknown
008	8kHz
011	11kHz
012	12kHz
016	16kHz
022	22kHz
024	24kHz
032	32kHz
044	44.1kHz
048	48kHz
064	64kHz
088	88.2kHz
096	96kHz
176	176.4kHz
192	192kHz

Step-4

14	14	14	.	15	:	16	16	16	16	:	17	17	17
----	----	----	---	----	---	----	----	----	----	---	----	----	----

14. Information of the input channels for listening mode transition

???	C_FMT_UNKNOWN
10	C_FMT_10
20	C_FMT_20
30	C_FMT_30
21	C_FMT_21
31	C_FMT_31
22	C_FMT_22
32	C_FMT_32
23	C_FMT_23
33	C_FMT_33
24	C_FMT_24
34	C_FMT_34
4H2	C_FMT_42H
5H2	C_FMT_52H
4W2	C_FMT_42W
5W2	C_FMT_52W
4H4	C_FMT_44H

4H3	C_FMT_43H
5H4	C_FMT_54H
5H3	C_FMT_53H
4W4	C_FMT_44W
4W3	C_FMT_43W
5W4	C_FMT_54W
5W3	C_FMT_53W
11	C_FMT_11

15. Information of the LFE channel input

0	SW 0ch
1	SW 1ch
2	SW 2ch

16. Channel information for the FL display

four-digit string "10.2" "5.1" "1 +1"

17. Number of channels after decoding

???	C_FMT_UNKNOWN
10	C_FMT_10
20	C_FMT_20
30	C_FMT_30
21	C_FMT_21

31	C_FMT_31
22	C_FMT_22
32	C_FMT_32
23	C_FMT_23
33	C_FMT_33
24	C_FMT_24
34	C_FMT_34
4H2	C_FMT_42H
5H2	C_FMT_52H
4W2	C_FMT_42W
5W2	C_FMT_52W
4H4	C_FMT_44H
4H3	C_FMT_43H
5H4	C_FMT_54H
5H3	C_FMT_53H
4W4	C_FMT_44W
4W3	C_FMT_43W
5W4	C_FMT_54W
5W3	C_FMT_53W
11	C_FMT_11

DEBUG MODE-4**AUDIO DEBUG MODE-4/5**

Step-5

2	:	18	:	19	19	19	19	:	20	20	20	20	
---	---	----	---	----	----	----	----	---	----	----	----	----	--

18. Audio output OK/NG

o	decode OK
x	decode NG

19. Details of input format

ANA	C_SRC_ANA
PCM	C_SRC_PCM
DLB	C_SRC_DD
DEX	C_SRC_DD_EX
DTS	C_SRC_DTS
MTR	C_SRC_DTS_MTR
DSC	C_SRC_DTS_DSC
D96	C_SRC_DTS_96
96M	C_SRC_DTS_96M
AAC	C_SRC_AAC
MCH	C_SRC_MCH
DSP	C_SRC_DSP
MPCM	C_SRC_MCHPCM
DSD	C_SRC_DSD
TRUE	C_SRC_TRUE
TREX	C_SRC_TRUE_EX
MSTR	C_SRC_MSTR
PLUS	C_SRC_DDPLUS
PLEX	C_SRC_DDPLUS_EX
EXP	C_SRC_DTSEXP
DTSH	C_SRC_DTSHD
DSUR	C_SRC_DD_SUR
DPSR	C_SRC_DDPLUS_SUR
TRSR	C_SRC_TRUE_SUR

20. Details of the format for the FL display

ANA	C_SRC_ANA
PCM	C_SRC_PCM
DLB	C_SRC_DD
DEX	C_SRC_DD_EX
DTS	C_SRC_DTS
MTR	C_SRC_DTS_MTR
DSC	C_SRC_DTS_DSC
D96	C_SRC_DTS_96
96M	C_SRC_DTS_96M
AAC	C_SRC_AAC
MCH	C_SRC_MCH
DSP	C_SRC_DSP
MPCM	C_SRC_MCHPCM
DSD	C_SRC_DSD
TRUE	C_SRC_TRUE
TREX	C_SRC_TRUE_EX
MSTR	C_SRC_MSTR
PLUS	C_SRC_DDPLUS
PLEX	C_SRC_DDPLUS_EX
EXP	C_SRC_DTSEXP
DTSH	C_SRC_DTSHD
DSUR	C_SRC_DD_SUR
DPSR	C_SRC_DDPLUS_SUR
TRSR	C_SRC_TRUE_SUR

Step-6

	21	21	:	22	:	23	:	24	24	24		25	25
--	----	----	---	----	---	----	---	----	----	----	--	----	----

21. Dialog norm

Dialog Norm value from 0 to 31

22. Return value of DIRINT Request_dir (DDC_STATUS)

o	LOCK
x	UNLOCK

23. Return value of DIR busy or free

Request_dir (DDC_BUSY)

F	Free
B	Busy

24. emphasis of information

ON	ON
OFF	OFF

25. HDDVD/BLUE(only DDPLUS)

BD	Bluray
HD	HDDVD

DEBUG MODE-5

AUDIO DEBUG MODE-5/5

Step-7

26	26	27	27	28	*	29	*	30	30	31	31	32	32
----	----	----	----	----	---	----	---	----	----	----	----	----	----

26. AudioIF DA830 input

IH	AUD_IF_I2S_H
DS	AUD_IF_DSD
IS	AUD_IF_I2S
NT	AUD_IF_NET
SP	AUD_IF_SPDIF
AD	AUD_IF_ADC
HR	AUD_IF_DDDTSHR

27. Information of DIR Burst Preamble

DS	DTSHD HR
DP	DD PLUS
Preamble Val	0x??

28. DIR Free or Busy

F	Free
B	Busy

29. DIR Detect Fs

00	CLOCK_FREQ_UNKNOWN
01	CLOCK_FREQ_8K
02	CLOCK_FREQ_11K
03	CLOCK_FREQ_12K
04	CLOCK_FREQ_16K
05	CLOCK_FREQ_22K
06	CLOCK_FREQ_24K
07	CLOCK_FREQ_32K
08	CLOCK_FREQ_44K
09	CLOCK_FREQ_48K
0A	CLOCK_FREQ_64K

0B	CLOCK_FREQ_88K
0C	CLOCK_FREQ_96K
0D	CLOCK_FREQ_128K
0E	CLOCK_FREQ_176K
0F	CLOCK_FREQ_192K

30. DIR sequence number

00	SEQ_DIG_POWEROFF
10	SEQ_DIG_RESET
11	SEQ_DIG_POWERON_WAIT
12	SEQ_DIG_RESTART
13	SEQ_DIG_WAIT_HDMI_FREE
20	SEQ_DIG_INPSEL_SET
30	SEQ_DIG_ANALOG_SET
31	SEQ_DIG_DIGITAL_SET
32	SEQ_DIG_MCHPCM_SET
33	SEQ_DIG_MCHANA_SET
34	SEQ_DIG_DDPDTSHD_SET
35	SEQ_DIG_NET_SET
40	SEQ_DIG_INIT_ERROR
41	SEQ_DIG_CHK_ERROR1
42	SEQ_DIG_CHK_ERROR2
43	SEQ_DIG_CHK_FREE
50	SEQ_DIG_CHK_ANALOG
60	SEQ_DIG_LOCK_PLL
61	SEQ_DIG_LOCK_ANA
f0	SEQ_DIG_FREE
f1	SEQ_DIG_FREE_ANA

31. DIR switch sequence number

00	SEQ_SWITCH_POWEROFF
01	SEQ_SWITCH_RESET
02	SEQ_SWITCH_POWERON_WAIT
03	SEQ_SWITCH_CHANGE
04	SEQ_SWITCH_FREE

32. DAC sequence number

00	SEQ_DAC_POWEROFF
01	SEQ_DAC_RESET
02	SEQ_DAC_POWERON_WAIT
03	SEQ_DAC_INITIALIZE
04	SEQ_DAC_RESTART
05	SEQ_DAC_CMND_SET
06	SEQ_DAC_FREE_WAIT
07	SEQ_DAC_FREE

Step-8

33	33	33	34	34	34	35	35	35	36	36	36		
----	----	----	----	----	----	----	----	----	----	----	----	--	--

33. Information of the input FS of DA830

UNK	C_FS_UNKNOWN
8	C_FS_08
11	C_FS_11
12	C_FS_12
16	C_FS_16
22	C_FS_22
24	C_FS_24
32	C_FS_32
44	C_FS_44
48	C_FS_48
64	C_FS_64
88	C_FS_88
96	C_FS_96
176	C_FS_176
192	C_FS_192

34. Information of the output FS of DA830

UNK	C_FS_UNKNOWN
8	C_FS_08
11	C_FS_11
12	C_FS_12
16	C_FS_16
22	C_FS_22
24	C_FS_24
32	C_FS_32
44	C_FS_44
48	C_FS_48
64	C_FS_64
88	C_FS_88
96	C_FS_96
176	C_FS_176
192	C_FS_192

35. Information of the input MCLK of DA830

64	AUD_MCLK_64Fs
128	AUD_MCLK_128Fs
256	AUD_MCLK_256Fs
384	AUD_MCLK_384Fs
512	AUD_MCLK_512Fs
640	AUD_MCLK_640Fs
768	AUD_MCLK_768Fs

36. State of the audio input of DA830

NO	AUD_STS_SOUND_NO
TRS	AUD_STS_SOUND_TRANS
STB	AUD_STS_SOUND_STAB

DEBUG MODE-6

HDMI DEBUG MODE-1/4

HDMI-related operations can be checked to some extent by displaying HDMI debug mode.

To enter this mode

Hold down **DISPLAY** button for 3 seconds. Information display will last for about 8 seconds.

Resolution display method

Input resolution

1 0 8 0 i / 6 0 →

Output resolution

1 0 8 0 i / 6 0

List of standard resolution

	4	8	0	i	/	6	0
	4	8	0	p	/	6	0
1	0	8	0	i	/	6	0
	7	2	0	p	/	6	0
1	0	8	0	p	/	6	0
	2	4	0	p	/	6	0
#	4	8	0	i	/	6	0
#	4	8	0	p	/	6	0
#	2	4	0	p	/	6	0
	5	7	6	i	/	5	0
	5	7	6	p	/	5	0
1	0	8	0	i	/	5	0
	7	2	0	p	/	5	0
1	0	8	0	p	/	5	0
	2	8	8	p	/	5	0

#	5	7	6	i	/	5	0
#	5	7	6	p	/	5	0
#	2	8	8	p	/	5	0
1	0	8	0	p	/	2	4
1	0	8	0	p	/	2	5
1	0	8	0	p	/	3	0
			V	G	A		
1	0	8	0	i	1	0	0
	7	2	0	p	1	0	0
	5	7	6	p	1	0	0
	5	7	6	i	1	0	0
1	0	8	0	i	1	2	0
	7	2	0	p	1	2	0
	4	8	0	p	1	2	0
	4	8	0	i	1	2	0

	5	7	6	p	2	0	0
	5	7	6	i	2	0	0
	4	8	0	p	/	6	0
	4	8	0	p	2	4	0
	4	8	0	i	2	4	0
*	4	8	0	p	/	6	0
*	5	7	6	p	/	5	0
	7	2	0	p	/	2	4
	7	2	0	p	/	2	5
	7	2	0	p	/	3	0

Display of Input Resolution

DVI input signal	<p>4 8 0 i / 6 0 →</p> <p>4 8 0 P / 6 0 →</p> <p>"i" and "P" will be capitalized.</p>
VGA input signal	<p>* V G A →</p> <p>Display the " *" in column 1</p>
No input	<p>U n k n o w n →</p>

DEBUG MODE-7

HDMI DEBUG MODE-2/4

Display of Output Resolution

For a video processor	Via VSP Display the "→" in column 4	1 0 8 0 i / 6 0
	VSP skip	1 0 8 0 i / 6 0
DVI input signal	i / p will be capitalized.	4 8 0 I / 6 0
		4 8 0 P / 6 0
VGA input signal	Display the "*" in column 5	* 4 8 0 p / 6 0
RSEN is OFF	Display the "*" in column 14	4 8 0 p / 6 0 *
EDID_READ is NG	Display the "#" in column 14	4 8 0 p / 6 0 #
Resolution Error	Display the "x" in column 14	4 8 0 p / 6 0 x
No output (Signal output destination can not be found.)		- - - - -
Hot-plug of Sink equipment can not be detected.		O F F

4K Upscaling

Display of Input resolution

1 0 8 0 i / 6 0 →

Display of Output resolution

* * * * x * * * * p / * * *

↓
* * * If the three-digit numbers are reframe

List of resolution

3 8 4 0 x 2 1 6 0 p / 3 0
 3 8 4 0 x 2 1 6 0 p / 2 5
 3 8 4 0 x 2 1 6 0 p / 2 4
 4 0 9 6 x 2 1 6 0 p / 2 4

Resolution Error

3 8 4 0 x 2 1 6 0 p / 3 0 x

EDID_READ_NG

3 8 4 0 x 2 1 6 0 p / 3 0 #

3D Display

Resolution display

1 0 8 0 p / 2 4 (3 D)

Status Display

H D M I 4 4 4 3 6 b i t

3D format

F r a m e P a c k i n g

INPUT/OUTPUT

I N : O U T :

RSEN OFF	Display the "*" in column 14	1 0 8 0 p / 2 4 (3 D) *
EDID READ NG	Display the "#" in column 9	H D M I 4 4 4 # 3 6 b i t
Resolution Error	Display the "x" in column 13	1 0 8 0 p / 2 4 (3 D) x

DEBUG MODE-8

HDMI DEBUG MODE-3/4

Status		
Input Mode	HDMI input	H D M I 4 4 4 3 6 b i t
	DVI input	D V I 4 4 4 3 6 b i t
	No input	- - - 4 4 4 3 6 b i t
Input Color	RGB	H D M I R G B 3 6 b i t
	422	H D M I 4 2 2 3 6 b i t
	444	H D M I 4 4 4 3 6 b i t
Deep Color	24bit	H D M I R G B 2 6 b i t
	30bit	H D M I R G B 3 0 b i t
	36bit	H D M I R G B 3 6 b i t

3D format	
Frame Packing	F r a m e P a c k i n g
Field alternative	F a l t e r n a t i v e
Line alternative	L a l t e r n a t i v e
Side-by-Side(Full)	S i d e b y S i d e (F)
L+depth	L + d e p t h
L+depth + graphics	L + d e p t h g r a p h i c
Side by Side(Harf)	S i d e b y S i d e (H)
Top and Bottom	T o p - a n d - B o t t o m
unknown	U N K N O W N
INPUT/ OUTPUT	I N : * * O U T : * *

DEBUG MODE-9
HDMI DEBUG MODE-4/4

PC Resolution

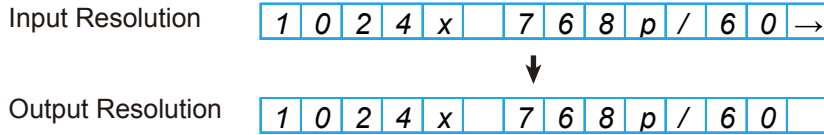

Display of Input resolution		* * * * x * * * * p / * * →
		Horizontal resolution Vertical resolution Referat
DVI input	Display uppercase P/i	1 0 2 4 x 7 6 8 P / 6 0 →
HDMI input	Display lowercase p/i	1 0 2 4 x 7 6 8 p / 6 0 →
Three-digit numbers are Referat		1 0 2 4 x 7 6 8 P 1 2 0 →
No input		U N K N O W N
Display of Output resolution		* * * * x * * * * p / * *
		Horizontal resolution Vertical resolution Referat
DVI output	Display uppercase P/i	1 0 2 4 x 7 6 8 P / 6 0
HDMI output	Display lowercase p/i	1 0 2 4 x 7 6 8 p / 6 0
Display "-----"		→ - - - - -
Three-digit numbers are Referat		1 0 2 4 x 7 6 8 P 1 2 0
EDID READ NG	Display the "# " in column 13	1 0 2 4 x 7 6 8 P / 6 0 #
Resolution through	Display the "x " in column 13	1 0 2 4 x 7 6 8 P / 6 0 x
INPUT/ OUTPUT		I N : * O U T : *

DEBUG MODE-10

SERVICE INFORMATION MODE

Displaying Service information

This service information display system is helpful in analyze the status when the unit goes into Protect mode and is powered off. Pay attention that the status will change if a button is pushed.

1. Press **twice** the **ON/ STANDBY** key while pressing the **DISPLAY** key.

e.g. M1.01/13204ALN — The version of main microprocessor is displayed only for 3 seconds.

2. Press **HOME** button within 3 seconds above.

e.g. - 80 °F 27 DD — Information Displayed (Record this Information)

Power off Cause Temperature Volume Level Listening Mode
 T : Thermal Protect : xx F or xx C ---> Refer to the code list below.
 V : Voltage Protect
 I : Current Protect
 - : Other

Listening Mode Code List

01	C_LM_LAST
02	C_LM_PURE
03	C_LM_DIRECT
04	C_LM_STEREO
05	C_LM_MONO
20	C_LM_SURR
50	C_LM_THX_MUSIC
70	C_LM_THX_GAME
90	C_LM_THX_CINEMA
A0	C_LM_THX_U2GAME
A8	C_LM_THX_U2MUSIC
B0	C_LM_THX_U2CINEMA

D0	C_LM_AUDYSSEY
48	C_LM_DTSSS
06	C_LM_ORCHESTRA
07	C_LM_UNPLUGGED
08	C_LM_STUDIOMIX
09	C_LM_TVLOGIC
0A	C_LM_ALLCHST
0B	C_LM_FULLMONO
0C	C_LM_TD
F1	C_LM_TESTTONE
F2	C_LM_TESTTHR
F3	C_LM_TESTAUTO

F4	C_LM_ASC
F5	C_LM_FLASH
F6	C_LM_DEBUGMODE
F7	C_LM_FLASH2
F8	C_LM_FLASH3
F9	C_LM_FLASH4
FA	C_LM_FLASH_CHECK
0D	C_LM_RPG
0E	C_LM_ACTION
0F	C_LM_ROCKBAND
10	C_LM_SPORTS

3. Press **HOME** button again. The following information are displayed.

e.g. 01:23 10h — Information Displayed (Record this Information)

Time after Power on Time after Initialize
 xx : xx xx hour

4. Press **ON/STANDBY** button to exit the display of service information.
 (Ref.: Press **RETURN** button to initialize the data in the service information.)

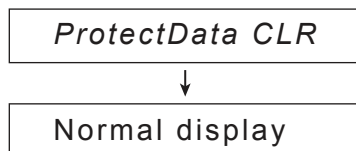

OPERATION CHECK-1

1.OPERATION CHECK(1/3)

1-1. OPERATIONS OF VOLTAGE-DETECTION PROTECTORS.

See "OPERATION CHECK-4,-6" for TEST MODE operation.

NOTE: Don't connect load nor short speaker terminals.

- Change the state to "TEST-4-21".
- It tests by being automatic in order of TEST 4-21(FL+) → 22(FR-) → 23(C+) → 24(SL-) → 25(SR+) → (26(SBL-) → 27(SBR+)). If TEST 4-27 is OK, it becomes the display of "TEST-4-35".
- It will complete, if displayed on FL TUBE as "TEST 4-35".

1-2. OPERATIONS OF CURRENT-DETECTION PROTECTORS

See "OPERATION CHECK-4,-6" for TEST MODE operation.

- Change the state to "TEST-4-35".
- Even if you connect 3-ohm load for every channel of L, R, C, SL, SR, SBL and SBRch, a relay should not cut off.
- If 1-ohm load is connected for every channel of L, R, C, SL, SR,SBL and SBRch, a relay should hold the state of ON.

1-3. CONFIRMATION OF RDS (RADIO DATA SYSTEM) OPERATION (Applied to MPP/MPB/MM* type)

- Input 98MHz,30dBμ signal modulated with RDS data.
- When a PS information is received, the name of the station "RDS TEST" shall be displayed within 2 seconds instead of the frequency.

1-4. CONFIRMATION OF HEAD PHONE OPERATION.

Confirm the Listening Mode is automatically switched to "STEREO" mode when headphones plug is inserted into the PHONES jack.

1-5. CONFIRMATION OF FRONT USB

See "OPERATION CHECK-4,-5" for TEST MODE operation.

- Connect ipod to AVR USB port.
- When set to TEST 3-09, confirm that the display of AVR change device name after few seconds.

1-6. CONFIRMATION OF NETWORK

See "OPERATION CHECK-4,-5" for TEST MODE operation.

- Connect the receiver to the router.
- When set to TEST 3-18 confirm that the display of AVR change IP adress.

*Please wait for about 1 minute after turning on the power supply of the set when you use TEST 3-18.

1-7. CONFIRMATION OF OUTPUT SENSOR AND THERMAL SENSOR

See "OPERATION CHECK-4,-6" for TEST MODE operation.

- Set the TEST MODE to "TEST 4-36".
After light "FM STEREO" on FL display,
the relays RL641/642 is OFF and "FM STEREO" is off .
- Push ON/Standby button 2 times while pushing down DISPLAY button to display CPU Debug PROGRAM version.
Push TONE button while displaying CPU PROGRAM version to display value of temperature sensor.
Confirm outside temperature ±20C is displayed immediately after energizing.
Note that the error margin is caused by the rise of the temperature of the heat sink when time passes.

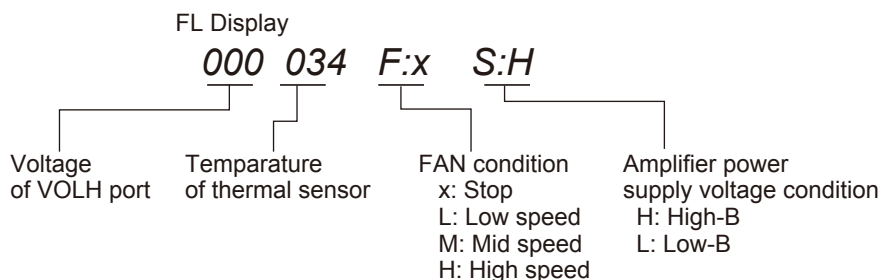

1-8. CONFIRMATION OF OSD(ON SCREEN DISPLAY) OPERATION

- When SETUP button is pushed, confirm that setup menu is displayed in HDMI Out.
- Confirm that specified operations for ENTER(with 4-cursor) buttons are made.

OPERATION CHECK-2

1. OPERATION CHECK(2/3)

1-9. CONFIRMATION OF HDMI AUDIO OPERATION.

See "OPERATION CHECK-4,-7" for TEST MODE operation.

a. CONFIRMATION OF HDMI I2S SIGNAL

1. Input the one of these signals below from HDMI1 terminal.

DTS-HD MasterAudio 7.1ch

Dolby TrueHD 7.1ch

2. Change the state to TEST 6-00. Confirm the signal is output from L/R,SW/C,SL/SR,SBL/SBR.

3. When TEST 6-08, confirm the sound(HDMI1 input) outputs from the TV.

b. CONFIRMATION OF HDMI SPDIF SIGNAL

4. SPDIF signal is input from HDMI terminal.

5. When TEST 6-06, confirm the sound(HDMI IN1) outputs from the speaker.

6. When TEST 6-07, confirm the sound(BD/DVD analog input) outputs from the TV.(VIDEO is Blueback)

c. CONFIRMATION OF HDMI DSD SIGNAL.

7. When TEST 6-10,11,12, confirm the sound of DSD 5.1ch input HDMI IN 3, output from the speaker.

1-10. VIDEO FUNCTION CHECK

See "OPERATION CHECK-4, -7" for TEST MODE operation.

a. Confirm Video output signal as shown Table 2, while Video signal are input as shown Table 1.

NOTE 1: Confirm the HDMI path at 1080p signal.

Table 1

Video Signal ->	Composite Video		Component		HDMI	
BD/DVD	A	F	IN1	F	IN1	H
CBL/SAT	B	---	IN2	G	IN2	I
STB/DVR	C	---	---	G	IN3	J
GAME	D	---	---	---	IN4	K
PC	P	---	---	---	IN5	L
IN6	---	---	---	---	IN6	M
IN7	---	---	---	---	IN7	N
AUX	E	---	---	---	AUX	O

Table 2

TX-NR626

Test mode	Output	Composite Video	Component	HDMI
		MONITOR OUT	OUT	Main OUT & Sub OUT
5-00(BD/DVD)		A	F	H
5-01(CBL/SAT)		B	---	I
5-02(STB/DVR)		---	---	J
5-03(GAME)		D	---	K
5-04(PC)		P	---	L
5-05(IN6)		---	---	M
5-06(IN7)		---	---	---
5-07(AUX)		E	---	---
5-08(BD/DVD)		*A	*F	F
5-09(BD/DVD)		*A	---	A

TX-NR727

Test mode	Output	Composite Video	Component	HDMI
		MONITOR OUT	OUT	OUT1
5-00(BD/DVD)		A	F	H
5-01(CBL/SAT)		B	---	I
5-02(STB/DVR)		C	---	J
5-03(GAME)		D	---	K
5-04(PC)		---	---	L
5-05(IN6)		---	---	M
5-06(IN7)		---	---	N
5-07(AUX)		---	---	O
5-08(BD/DVD)		*A	*F	F
5-09(BD/DVD)		*A	---	A

TX-NR828

Test mode	Output	Composite Video	Component	HDMI
		MONITOR OUT	OUT	OUT1
5-00(BD/DVD)		A	F	H
5-01(CBL/SAT)		B	G	I
5-02(STB/DVR)		C	---	J
5-03(GAME)		D	---	K
5-04(PC)		---	---	L
5-05(IN6)		---	---	M
5-06(IN7)		---	---	N
5-07(AUX)		E	---	O
5-08(BD/DVD)		*A	*F	F
5-09(BD/DVD)		*A	---	A

DTR-30.5

Test mode	Output	Composite Video	Component	HDMI
		MONITOR OUT	OUT	OUT1
5-00(BD/DVD)		A	F	H
5-01(CBL/SAT)		B	G	I
5-02(STB/DVR)		---	---	J
5-03(GAME)		D	---	K
5-04(PC)		P	---	L
5-05(IN6)		---	---	M
5-06(IN7)		---	---	---
5-07(AUX)		E	---	---
5-08(BD/DVD)		*A	*F	F
5-09(BD/DVD)		*A	---	A

DTR-40.5

Test mode	Output	Composite Video	Component	HDMI
		MONITOR OUT	OUT	OUT1
5-00(BD/DVD)		A	F	H
5-01(CBL/SAT)		B	G	I
5-02(STB/DVR)		C	---	J
5-03(GAME)		D	---	K
5-04(PC)		---	---	L
5-05(IN6)		---	---	M
5-06(IN7)		---	---	N
5-07(AUX)		E	---	O
5-08(BD/DVD)		*A	*F	F
5-09(BD/DVD)		*A	---	A

DTR-50.5

Test mode	Output	Composite Video	Component	HDMI
		MONITOR OUT	OUT	OUT1
5-00(BD/DVD)		A	F	H
5-01(CBL/SAT)		B	G	I
5-02(STB/DVR)		C	---	J
5-03(GAME)		D	---	K
5-04(PC)		---	---	L
5-05(IN6)		---	---	M
5-06(IN7)		---	---	N
5-07(AUX)		E	---	O
5-08(BD/DVD)		*A	*F	F
5-09(BD/DVD)		*A	---	A

OPERATION CHECK-3

1.OPERATION CHECK(3/3)

b. OPERATIONS OF VIDEO SIGNAL-DETECTION

1. Confirm "RDS" light up on FL TUBE when component video signal is input in "TEST 5-00".
Confirm "RDS" turn off on FL TUBE when component video signal isn't input in "TEST 5-00",too.
2. Confirm "FM STEREO" light up on FL TUBE when component video signal is input in "TEST 5-00".
Confirm "FM STEREO" turn off on FL TUBE when component video signal isn't input in "TEST 5-00",too.

1-11. CONFIRMATION OF 12V TRIGGER OPERATIONS(TX-NR828,DTR-30.5/40.5/50.5 ONLY)

See "OPERATION CHECK-4, -5" for TEST MODE operation.

- a. After checking that there is no output from 12V TRIGGER A terminal,it checks that there is an output of $12V \pm 10\%$ /150mA after switched the "TEST2-11".
- b. After checking that there is no output from 12V TRIGGER B terminal,it checks that there is an output of $12V \pm 10\%$ /25mA after about 1 seconds switched the "TEST2-12". (DTR-30.5/40.5/50.5 ONLY)
- c. After checking that there is no output from 12V TRIGGER C terminal,it checks that there is an output of $12V \pm 10\%$ /25mA after 2 seconds switched the "TEST2-13". (DTR-30.5/40.5/50.5 ONLY)

1-12. CONFIRMATION OF COOLING FAN OPERATION

See "OPERATION CHECK-4,-6" for TEST MODE operation.

- a. Confirm to fan no rotate.
- b. When TEST 4-36 or TEST 4-37, confirm to fan rotate.

1-13. CONFIRMATION OF Wi-Fi CONNECTION

- a. After setting wifi routers, change the state to "IDLING TIMER MODE".
See "OPERATION CHECK-4, -6" for TEST MODE operation.
 - b. It connects an access point automatically. Wi-Fi LED flashes during connection.
 - c. When connection is completed and IP address is able to be acquired, Wi-Fi LED lights up and the value of RSSI to an access point is displayed per dbm.
If the connection failed, NG is displayed.
- * If the connection failed, exit the idle mode by pressing the TV/CD button and please try again from [a].

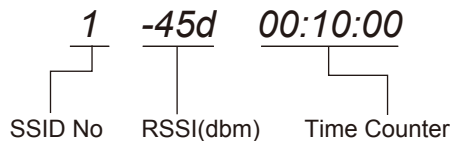

1-14. MISCELLANEOUS

- a. Confirm all input and output terminals operate normally.
- b. Please confirm LED and FL displaying by the FL test mode. And confirm the destination setting.
---> See to "OPERATION CHECK-4" for TEST MODE operation.
- c. Change the state to KEY TEST under TEST MODE described in Section 2-2. to confirm each key operation.
---> See to "OPERATION CHECK-4" for TEST MODE operation.
- d. Confirm the version of each firmware.---> See to "SERVICE PROCEDURE-2"
- e. Confirm the firmware combination check.---> See to "OPERATION CHECK-4" for TEST MODE operation.
- f. CPlease confirm the Check Sum.---> See to "OPERATION CHECK-4" for TEST MODE operation.

OPERATION CHECK-4

2.TEST MODE(1/4)

2-1.TEST MODE FOR MODEL, DESTINATION AND FL DISPLAY

NOTE: If VOL value is not **25**(initial setting), test mode cannot be set.(TX-NR626, HT-RC560, DTR-30.5)

NOTE: If VOL value is not **30**(initial setting), test mode cannot be set.(TX-NR727, TX-NR828,DTR-40.5, DTR-50.5)

- Push STANDBY/ON key while pushing down TV/CD button to display "TEST-".
- Then push DIMMER(RT/PTY/TP) button and get the FL test mode.
- In the FL test mode, TONE - button is FL TEST UP and TONE + button is FL TEST DOWN.
- REC OUT and ZONE2 button's originally operation can't work when it is in FL test mode.
- The contents of the step are as follows.
 - Lit all segment
 - Lit '23456789ABCDEF'
 - Lit a even number segment
 - Lit an odd number segment
 - The Destination setting is displayed. Please see the below for detail.
- To close the FL test, push POWER button.

Display of Destination on TEST MODE.(Distination setting))

e.g. **NR626 Dx 2000**

FL DIS Name Destination A B C D

A:Value of AD port of BAND
 B:Value of AD port of INIT1
 C:Value of AD port of INIT2
 D:Value of AD port of INIT3

Model Name	Distination	Number	Writing Data	FL Display												
TX-NR626	DD/DC	2000	2000 TX-NR626 Dx	N	R	6	2	6			D	x	2	0	0	0
TX-NR626	DF	0000	0000 TX-NR626 DF	N	R	6	2	6			D	F	0	0	0	0
TX-NR626	xx	8000	8000 TX-NR626 xx	N	R	6	2	6			x	x	8	0	0	0
TX-NR626	JJ	4000	4000 TX-NR626 JJ	N	R	6	2	6			J	J	4	0	0	0
HT-RC560	Dx	2002	2002 HT-RC560 Dx	R	C	5	6	0			D	x	2	0	0	2
DTR-30.5	Dx	2040	2040 DTR-30.5 Dx	D	T	R	3	0	5		D	x	2	0	4	0
DTR-30.5	xx	8040	8040 DTR-30.5 xx	D	T	R	3	0	5		x	x	8	0	4	0
DTR-30.5	JJ	4040	4040 DTR-30.5 JJ	D	T	R	3	0	5		J	J	4	0	4	0
TX-NR727	DD/DC	2200	2200 TX-NR727 Dx	N	R	7	2	7			D	x	2	2	0	0
TX-NR727	DF	0200	0200 TX-NR727 DF	N	R	7	2	7			D	F	0	2	0	0
TX-NR727	xx	8200	8200 TX-NR727 xx	N	R	7	2	7			x	x	8	2	0	0
TX-NR727	JJ	4200	4200 TX-NR727 JJ	N	R	7	2	7			J	J	4	2	0	0
DTR-40.5	Dx	2240	2240 DTR-40.5 Dx	D	T	R	4	0	5		D	x	2	2	4	0
DTR-40.5	xx	8240	8240 DTR-40.5 xx	D	T	R	4	0	5		x	x	8	2	4	0
TX-NR828	DD/DC	2400	2400 TX-NR828 Dx	N	R	8	2	8			D	x	2	4	0	0
TX-NR828	xx	8400	8400 TX-NR828 xx	N	R	8	2	8			x	x	8	4	0	0
DTR-50.5	Dx	2440	2440 DTR-50.5 Dx	D	T	R	5	0	5		D	x	2	4	4	0
DTR-50.5	xx	8440	8440 DTR-50.5 xx	D	T	R	5	0	5		x	x	8	4	4	0

2-2. TEST MODE FOR OPERATION

- Push STANDBY/ON button while pushing down TV/CD button to display "TEST-_".
- Next, if the following keys are pushed, it becomes a each TEST MODE.
- In the test mode, (TONE)- button is TEST MODE DOWN and (TONE)+ button is TEST MODE UP.
- "TEST-1-00" and "TEST-1-01" are used to check a protection circuit, and the relay recovered in one second.

TEST MODE	1-00	2-00	3-00	4-00	5-00	6-00	KEY TEST
TX-NR626/ DTR-30.5/ HT-RC560	BD/DVD	CBL/SAT	GAME	PC	AUX	TUNER	MEMORY
TX-NR727/ DTR-40.5			CBL/SAT	GAME	PC	AUX	
TX-NR828/ DTR-50.5			GAME1	GAME2	PC		

TEST MODE	IDLING TIMER / w/Wi-Fi check	FL TEST	FIRMWARE COMBINATION CHECK	CHECK SUM
TX-NR626/ DTR-30.5/ HT-RC560/ TX-NR727/ DTR-40.5/ TX-NR828/ DTR-50.5	TUNING MODE (LATE NIGHT)	DIMMER (RT/PTY/TP)	ENTER	When MMPU debug version(*1) is displayed, push "MEMORY"

(*1) MMPU debug version is displayed

Press **twice** the **ON/ STANDBY** key while pressing the **DISPLAY** key.

OPERATION CHECK-5

2.TEST MODE(2/4)

2-2. TEST MODE FOR OPERATION(Continue)

e. Test mode is as follows.

[NOTE] Do not connect the loudspeaker.

No	Analog Input [Rec Sel] (Zone2/Zone3)	Listening Mode/ Input Format	VIDEO Input	Component V	HDMI	12V TRG	Digital Input /Output	Config.	Master Vol. Non THX (THX)	Speaker Relay	etc.
1-00	BD/DVD (Off)	Direct	BD/DVD	IN1	IN1	-	-	-	Max(Max)	F/CS/SB/Z2	*1 PROTECT
1-01	BD/DVD (Off)	Direct	BD/DVD	IN1	IN1	-	-	-	Max(Max)	F/CS/SB/Z2	SBL_SBR *1 PROTECT_For SBL ch
1-02	BD/DVD (Off)	Direct	BD/DVD	IN1	IN1	-	-	-	MIN(Min)	F/CS/SB/Z2	
2-00	BD/DVD (Off)	Stereo(Direct)	BD/DVD	IN1	IN1	-	-	-	Max(Max)	F	SW=NO
2-01	BD/DVD (Off)	Stereo(Direct)	BD/DVD	IN1	IN1	-	-	-	64(Ref)	F	SW=NO
2-02	BD/DVD (Off)	DVD Direct	BD/DVD	IN1	IN1	-	-	Y/L/L/L/L	Max(Max)	F/CS/SB	
2-03	Multi channel	Multi ch Amp Test	BD/DVD	IN1	IN1	-	-	Y/L/L/L/L	64(Ref)	F/CS/SB	
2-04	BD/DVD (Off)	VOL Direct	BD/DVD	IN1	IN1	-	-	Y/L/L/L/L	Max(Max)	F/CS/SB	L in ->L,SL,SBL / R in ->R,SR,SBR
2-05	BD/DVD (Off)	ADC DSP 8ch Thru.	BD/DVD	IN1	IN1	-	-	Y/L/L/L/L	Max(Max)	F/CS/SB	
2-06	BD/DVD (Off)	ADC DSP 8ch Thru.	BD/DVD	IN1	IN1	-	-	Y/L/L/L/L	62(80)	F/CS/SB	
2-07	BD/DVD (Off)	ADC DSP 7ch Thru.	BD/DVD	IN1	IN1	-	-	Y/L/L/L/L	64(Ref)	F/CS/SB	SW:MUTE
2-08	BD/DVD (Off)	ADC DSP 8ch Thru.	BD/DVD	IN1	IN1	-	-	Y/L/L/L/L	57(75)	F/CS/SB	
2-09	BD/DVD (Off)	ADC DSP 8ch Thru.	BD/DVD	IN1	IN1	-	-	Y/L/L/L/L	52(70)	F/CS/SB	
2-10	BD/DVD (Off)	ADC DSP 8ch Thru.	BD/DVD	IN1	IN1	-	-	Y/L/L/L/L	MIN(Min)	CS/SB	SPRLF OFF
2-11	CBL/SAT (Off)	Automatic	CBL/SAT	-	IN2	A	*OPT1	Y/L/L/L/L	64(Ref)	F/CS/SB	
2-12	CBL/SAT (Off)	Automatic	CBL/SAT	-	IN2	B	*COAX1	Y/L/L/L/L	64(Ref)	F/CS/SB	
2-13	CBL/SAT (Off)	DIR DSP 8ch Thru	CBL/SAT	-	IN3	C	*OPT1	Y/L/L/L/L	64(Ref)	F/CS/SB	AMUT OFF
2-14	GAME (Off)	DIR DSP 8ch Thru	GAME	-	IN4	-	-	64(Ref)			
2-15	AUX (Off)	DIR DSP 8ch Thru	AUX	-	-	-	OPT1	Y/L/L/L/L	64(Ref)	F/CS/SB	
2-16	BD/DVD (Off)	DIR DSP 8ch Thru	BD/DVD	-	-	-	COAX1	Y/L/L/L/L	Max(Max)	F/CS/SB	
2-17	BD/DVD (Off)	DIR DSP 8ch Thru	BD/DVD	-	-	-	COAX1	Y/L/L/L/L	64(Ref)	F/CS/SB	
2-18	CBL/SAT (Off)	Automatic	BD/DVD	BD/DVD	IN2	-	*OPT2	Y/L/L/L/L	52(70)	F/CS/SB	
2-19	BD/DVD (Off)	DIR DSP 8ch Thru	BD/DVD	BD/DVD	IN2	-	*OPT2	Y/L/L/L/L	64(Ref)	F/CS/SB	
2-20	BD/DVD (Off)	DIR DSP 8ch Thru	BD/DVD	BD/DVD	IN2	-	*OPT2	Y/L/L/L/L	64(Ref)	F	
2-21	BD/DVD (Off)	DIR DSP 8ch Thru	BD/DVD	BD/DVD	IN3	-	*COAX2	Y/L/L/L/L	64(Ref)	F	
2-22	BD/DVD(Source)	DIR DSP 8ch Thru	BD/DVD	BD/DVD	IN3	-	-	Y/L/L/L/L	64(Ref)	CS	
2-23	MIC	ADC DSP 8ch Thru.	BD/DVD	BD/DVD	IN1	-	-	Y/L/L/L/L	64(Ref)	F/CS/SB	
2-24	MIC	ADC DSP 8ch Thru.	BD/DVD	BD/DVD	IN1	-	-	Y/L/L/L/L	64(Ref)	F/CS/SB	MICMUTE ON
2-25	BD/DVD (Off)	Whole House Mode	BD/DVD	IN1	IN1	-	-	Y/L/L/L/L	64(Ref)	F/CS/SB	Whole House Mode
2-26	PC (Off)	DIR DSP 8ch Thru	-	-	-	-	OPT1	Y/L/L/L/L	64(Ref)	F/CS/SB	
2-27	PHONO/Source	Direct	BD/DVD	-	-	-	-	Max(Max)	F		
2-28	PHONO/Source	Direct	BD/DVD	-	-	-	-	62(80)	F		
3-00	FM/Source	Stereo(Direct)	BD/DVD	BD/DVD	IN1	-	-	64(Ref)	F		
3-01	TV/CD	Stereo(Direct)	BD/DVD	BD/DVD	IN1	-	-	Max(Max)	F/Z2		Powed:ON, LINE/PRE:LINE, Z2VOL:64(82)
3-02	TV/CD	Stereo(Direct)	BD/DVD	BD/DVD	IN1	-	-	64(Ref)	F/Z2		Powed:ON, TX:LINE/DTR:PRE, Z2VOL:64(82)
3-03	TV/CD	Stereo(Direct)	BD/DVD	BD/DVD	IN1	-	-	64(Ref)	F/Z2	Z2MUTE ON	Powed:ON, LINE/PRE:LINE, Z2VOL:64(82)
3-04	TV/CD (Off)	ALL CH STEREO	BD/DVD	BD/DVD	IN1	-	-	Y/L/L/L/L	64(Ref)	F/CS/FH	
3-08	TV(BD/GAME)	Stereo(Direct)	Last (BD/DVD)	-	-	-	-	Min/Min	F/Z2/Z3		Powed:ON, LINE/PRE:PRE, Z2/Z3Vol=64(82)
3-09	USB/(Source)	Stereo(Direct)	Last	-	-	-	Front USB	57(75)	F		Powed:OFF, LINE/PRE:LINE, Z2VOL:-
3-11	USB/(Source)	Stereo(Direct)	Last	-	-	-	Front USB	48	F		1.44.1kHz_16bit_1kHz_ 0dBfs L&R.wav *2
3-12	USB/(Source)	Stereo(Direct)	Last	-	-	-	Front USB	48	F		2.44.1kHz_16bit_∞ dBfs L&R.wav *2
3-13	USB/(Source)	Stereo(Direct)	Last	-	-	-	Front USB	48	F		3.44.1kHz_16bit_20Hz_ 0dBfs L&R.wav *2
3-14	USB/(Source)	Stereo(Direct)	Last	-	-	-	Front USB	48	F		4.44.1kHz_16bit_20kHz z_0dBfs L&R.wav *2
3-15	USB/(Source)	Stereo(Direct)	Last	-	-	-	Front USB	48	F		5.44.1kHz_16bit_1kHz_ 0dBfs Lch.wav *2
3-16	USB/(Source)	Stereo(Direct)	Last	-	-	-	Front USB	48	F		6.44.1kHz_16bit_1kHz_ 0dBfs Rch.wav *2
3-17	USB/(Source)	Stereo(Direct)	Last	-	-	-	Front USB	48	F		7.48kHz_16bit_1kHz_0 dBfs L&R.wav *2
3-18	NET/(Source)	Stereo(Direct)	Last	-	-	-	NET	48	F	NET connection check	display IP address
3-20	GAME (TV/CD)	Stereo(Direct)	BD/DVD	BD/DVD	IN1	-	-	64(Ref)	F/Z2		Powed:ON LINE/PRE:PRE Z2 Bass=Max
3-21	GAME (TV/CD)	Stereo(Direct)	BD/DVD	BD/DVD	IN1	-	-	64(Ref)	F/Z2		Powed:ON LINE/PRE:PRE Z2 Bass=Min
3-22	GAME (TV/CD)	Stereo(Direct)	BD/DVD	BD/DVD	IN1	-	-	64(Ref)	F/Z2		Powed:ON LINE/PRE:PRE Z2 Treble=Max
3-23	GAME (TV/CD)	Stereo(Direct)	BD/DVD	BD/DVD	IN1	-	-	64(Ref)	F/Z2		Powed:ON LINE/PRE:PRE Z2 Treble=Min

*You must move to T 4-** after T 2-25.

In all test modes, it is not concerned with detection of VOLH but SEC1H are made "H" fixation. (Except TEST4-36 and 4-37.)

*1: All SP-RELAYS are turned ON only at the time of this STEP.

Moreover, whether make RELAY restoration time at the time of protection operation into 1 second, and PROTECT input "H" is detected

how many times or it continues 1 second or more, RELAY is not held at OFF or POWER OFF is not carried out, either.

When "H" is 1 seconds or more to PROTECT input and it is set to "L", RELAY is turned ON again.

Moreover, not any MUTE is outputted at the time of this STEP.

OPERATION CHECK-6

2.TEST MODE(3/4)

2-2. TEST MODE FOR OPERATION(Continue)

Auto Measurement Mode

TEST No.	DSP Output ch	DSP Output Frequency	DSP Output Voltage	Config.	Master Vol.	Speaker Relay	etc.
4-00	ALL	1kHz	-20dBFS	Y/L/L/L/L	64(Ref)	F/CS/SB	*6 DSP Gain
4-01	ALL	30Hz	-20dBFS	Y/L/L/L/L	64(Ref)	F/CS/SB	*6 DSP Freq.Response
4-02	ALL	20kHz	-20dBFS	Y/L/L/L/L	64(Ref)	F/CS/SB	*6 DSP Freq.Response
4-03	SW	30Hz	-20dBFS	N/L/L/L/L	58(76)	F/CS/SB	*6 Characteristic(1)
4-04	FL,FR	30Hz	-20dBFS	N/L/L/L/L	64(Ref)	F/CS/SB	*6 Characteristic(2)
4-05	FR,C,SL,SR,SBL,SBR,SW	10kHz	-20dBFS	Y/L/L/L/L	64(Ref)	F/CS/SB	Mute:FL *6 Separation
4-06	FL,C,SL,SR,SBL,SBR,SW	10kHz	-20dBFS	Y/L/L/L/L	64(Ref)	F/CS/SB	Mute:FR *6 Separation
4-07	FL,FR,SL,SR,SBL,SBR,SW	10kHz	-20dBFS	Y/L/L/L/L	64(Ref)	F/CS/SB	Mute:C *6 Separation
4-08	FL,FR,C,SR,SBL,SBR,SW	10kHz	-20dBFS	Y/L/L/L/L	64(Ref)	F/CS/SB	Mute:SL *6 Separation
4-09	FL,FR,C,SL,SBL,SBR,SW	10kHz	-20dBFS	Y/L/L/L/L	64(Ref)	F/CS/SB	Mute:SR *6 Separation
4-10	FL,FR,C,SL,SR,SBR,SW	10kHz	-20dBFS	Y/L/L/L/L	64(Ref)	F/CS/SB	Mute:SBL *6 Separation
4-11	FL,FR,C,SL,SR,SBL,SW	10kHz	-20dBFS	Y/L/L/L/L	64(Ref)	F/CS/SB	Mute:SBR *6 Separation
4-12	FL,FR,C,SL,SR,SBL,SBR	30Hz	-20dBFS	Y/L/L/L/L	64(Ref)	F/CS/SB	Mute:SW *6 Separation
4-13	ALL	1kHz	-20dBFS	Y/L/L/L/L	64(Ref)	F/CS/SB	*mut on *6 Muting
4-14	ALL	30Hz	-20dBFS	Y/L/L/L/L	64(Ref)	F/CS/SB	*mut on *6 Muting
4-15	ALL	1kHz	-20dBFS	Y/L/L/L/L	Min(Min)	F/CS/SB	*6 Volume Max.Attenuation
4-16	ALL	30Hz	-20dBFS	Y/L/L/L/L	Min(Min)	F/CS/SB	*6 Volume Max.Attenuation
4-21	FL	+DC	+Max	Y/L/L/L/L	Max(Max)	F/CS/SB	*1,*3 +DC Protect
4-22	FR	-DC	-Max	Y/L/L/L/L	Max(Max)	F/CS/SB	*1,*3 -DC Protect
4-23	C	+DC	+Max	Y/L/L/L/L	Max(Max)	F/CS/SB	*1,*3 +DC Protect
4-24	SL	-DC	-Max	Y/L/L/L/L	Max(Max)	F/CS/SB	*1,*3 -DC Protect
4-25	SR	+DC	+Max	Y/L/L/L/L	Max(Max)	F/CS/SB	*1,*3 +DC Protect
4-26	SBL	-DC	-Max	Y/L/L/L/L	Max(Max)	F/CS/SB	*1,*3 -DC Protect
4-27	SBR	+DC	+Max	Y/L/L/L/L	Max(Max)	F/CS/SB	*1,*3 +DC Protect
4-28	FL	-DC	-Max	Y/L/L/L/L	Max(Max)	F/CS/SB	*1,*3 -DC Protect
4-29	FR	+DC	+Max	Y/L/L/L/L	Max(Max)	F/CS/SB	*1,*3 +DC Protect
4-30	C	-DC	-Max	Y/L/L/L/L	Max(Max)	F/CS/SB	*1,*3 -DC Protect
4-31	SL	+DC	+Max	Y/L/L/L/L	Max(Max)	F/CS/SB	*1,*3 +DC Protect
4-32	SR	-DC	-Max	Y/L/L/L/L	Max(Max)	F/CS/SB	*1,*3 -DC Protect
4-33	SBL	+DC	+Max	Y/L/L/L/L	Max(Max)	F/CS/SB	*1,*3 +DC Protect
4-34	SBR	-DC	-Max	Y/L/L/L/L	Max(Max)	F/CS/SB	*1,*3 -DC Protect
4-35	ALL	Pulse	Max	Y/L/L/L/L	58(76)	F/CS/SB	*1,*4 Current Protect
4-36	"FL,FR,C,SL,SR"	1kHz	0dBFS	Y/L/L/L/L	64(Ref)	F/CS/SB	vol=64 VOLH DET,FAN Low
4-37	C,SL,SR,SBL,SBR	1kHz	0dBFS	Y/L/L/L/L	64(Ref)	F/CS/SB	*5 VOLH DET,FAN High
4-38	*7						Key Test,SEC1H="L"

*3 : When TEST No. 4-21 ~ 34 is setted, DC vorage is putted out immediately at each channel. (within 100msec.)

*4 : The following signal is putted out at all channel continuously in TEST4-35

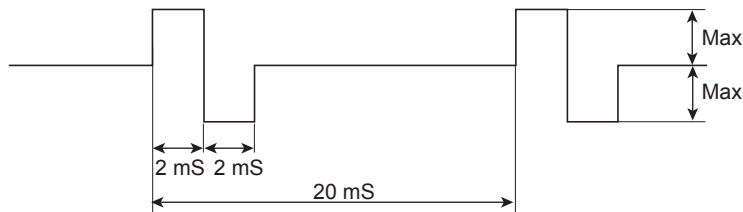

*5 : VOLH is detected and H/L of SEC1H is changed.

A detection level is the same as the normal mode.

When it is detected, light "FM STEREO" on FL TUBE.

*7 : In TEST4-38, some character is displayed while pushing down some button. Another character shall be displayed by each button.

OPERATION CHECK-7

2.TEST MODE(4/4)

2-2. TEST MODE FOR OPERATION(Continue)

VIDEO & HDMI TEST MODE

TEST No.	Input selector	DIGITAL INPUT	COMPO-NENT	Volume NonTHX/THX	HDMI	MODE	etc
5-00	BD/DVD	HDMI	IN1	31/51	IN1	Through(Main/Sub:Both)	Audio TV OUT = ON
5-01	CBL/SAT	HDMI	IN2	31/51	IN2	Through(Main/Sub:Both)	Audio TV OUT = ON
5-02	GAME	HDMI	-	31/51	IN3	Through(Main/Sub:Both)	Audio TV OUT = ON
5-03	PC	HDMI	-	31/51	IN4	Through(Main/Sub:Both)	Audio TV OUT = ON
5-04	IN5	HDMI	-	31/51	IN5	Through(Main/Sub:Both)	Audio TV OUT = ON
5-05	IN6	HDMI	-	31/51	IN6	Through(Main/Sub:Both)	Audio TV OUT = ON
5-06	IN7	HDMI	-	31/51	IN7	Through(Main/Sub:Both)	Audio TV OUT = ON
5-07	AUX	HDMI	-	31/51	AUX	Through(Main/Sub:Both)	Audio TV OUT = ON
5-08	BD/DVD	-	IN1	MIN	-	COMPONENT--->HDMI(Main/Sub:Both)	
5-09	AUX	-	-	MIN	-	CV--->HDMI(Main/Sub:Both)	
6-00	BD/DVD	HDMI	IN1	40/60	IN1	HDMI I2S SIGNAL	OUTPUT CH=L/R/C/SW/SL/SR
6-04	BD/DVD	HDMI	IN1	40/60	IN3	HDMI DSD SIGNAL	OUTPUT CH = L/R/C/SW/SL/SR
6-06	BD/DVD	HDMI	IN1	40/60	IN1	HDMI SPDIF SIGNAL	
6-07	BD/DVD	COAX1*	IN1	MIN	---	Audio TV OUT = ON, VOL=0, ANALOG(DVD)	HDMI OUT is blue back
6-08	BD/DVD	HDMI	IN1	MIN	IN1	Audio TV OUT = ON, VOL=0, I2S SIGNAL	
6-09	CBL/SAT	HDMI ARC	IN2	40/60	---	HDMI AUDIO RETURN CHANNEL	
6-10	BD/DVD	HDMI	IN1	40/60	IN3	HDMI DSD SIGNAL	Output CH = L/R to L/R
6-11	BD/DVD	HDMI	IN1	40/60	IN3	HDMI DSD SIGNAL	Output CH = C/SW to L/R
6-12	BD/DVD	HDMI	IN1	40/60	IN3	HDMI DSD SIGNAL	Output CH = SL/SR to L/R
6-14	BD/DVD	HDMI	IN1	30/50	IN2	Normal operation	DIRECT
6-20	BD/DVD AUX	HDMI	-	31/51	IN1 AUX	MHL Check(CABLE DET)	
6-21	BD/DVD AUX	HDMI	-	31/51	IN1 AUX	MHL Check(VBUS=OFF)	
6-22	BD/DVD AUX	HDMI	-	31/51	IN1 AUX	MHL Check(VBUS=ON)	

NOTES

1. DSP Thru of Listening Mode outputs L Input signal to L/C/SL/SBL, and outputs R Input signal to R/SR/SBR/SW.
2. Config. is in order of SW/Front/Center/Surround/Surround Back
3. Mute is function to stop output(from the channel) by using inner DSP programming.
4. When Listening Mode is DSP thru, an analog SW is changed into the state of SURROUND.
5. At the time of PRTCTTHM detection, it is displayed on FLT as "THERMAL PROTECT".

f. Following frequencies are automatically written in the preset memory, when the unit goes into test mode.

	PRESET No.	MD*	MW*(10k)	MP*,MG* MW*(9k)	MJJ
FM	1	89.9MHz	89.90MHz	89.90MHz	76.0MHz
	2	97.9MHz	97.90MHz	97.90MHz	82.0MHz
	3	98.9MHz	98.90MHz	98.90MHz	83.0MHz
	4	107.1MHz	107.10MHz	107.10MHz	84.0MHz
	5	107.9MHz	107.90MHz	107.90MHz	90.0MHz
	6	100.1MHz	100.10MHz	100.10MHz	80.0MHz
	7	88.1MHz	88.10MHz	88.10MHz	85.1MHz
	8	104.1MHz	104.10MHz	104.10MHz	88.1MHz
	9	95.3MHz	95.30MHz	95.30MHz	76.0MHz
	10	106.7MHz	106.70MHz	106.70MHz	90.0MHz
AM	11	530KHz	530KHz	522KHz	522kHz
	12	630KHz	630KHz	630KHz	630kHz
	13	990KHz	990KHz	990KHz	990kHz
	14	1440KHz	1440KHz	1440KHz	1440kHz
	15	1710KHz	1710KHz	1611KHz	1611kHz
	16	670KHz	670KHz	666KHz	666kHz
	17	830KHz	830KHz	828KHz	828kHz
	18	1310KHz	1310KHz	1314KHz	1314kHz
	19	1200KHz	1200KHz	1197KHz	1197kHz
	20	530KHz	530KHz	522KHz	522kHz
FM	21	87.5MHz	87.50MHz	87.50MHz	76.0MHz
	22	107.9MHz	108.00MHz	108.00MHz	90.0MHz
	23	103.7MHz	104.00MHz	104.00MHz	79.8MHz
	24	104.5MHz	104.20MHz	104.20MHz	80.2MHz
AM	25	1180kHz	1180kHz	1179kHz	1179kHz
	26	1220kHz	1220kHz	1215kHz	1215kHz

OPERATION CHECK-8

COOLING FAN

Circuit

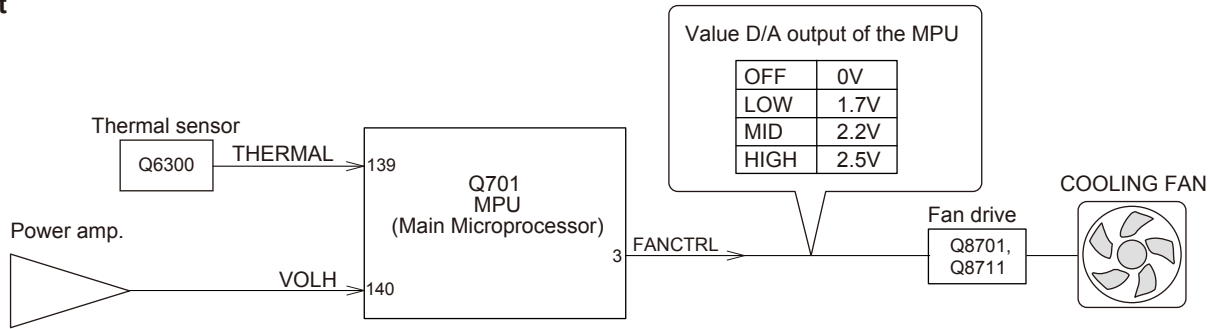

Condition to operate

		VOLH							
		Normal/ Bi-Amp				Powerd Zone-2, 3			
		OFF or Headphone	LOW	MID	HIGH	OFF or Headphone	LOW	MID	HIGH
THERMAL	OFF	LOW	STOP	STOP	STOP	STOP	STOP	STOP	STOP
	LOW	LOW	LOW	LOW	LOW	LOW	LOW	LOW	LOW
	MID	LOW	MID	MID	MID	MID	MID	MID	MID
	HIGH	MID	HIGH	HIGH	HIGH	HIGH	HIGH	HIGH	HIGH

THERMAL(Temperature of thermal sensor)

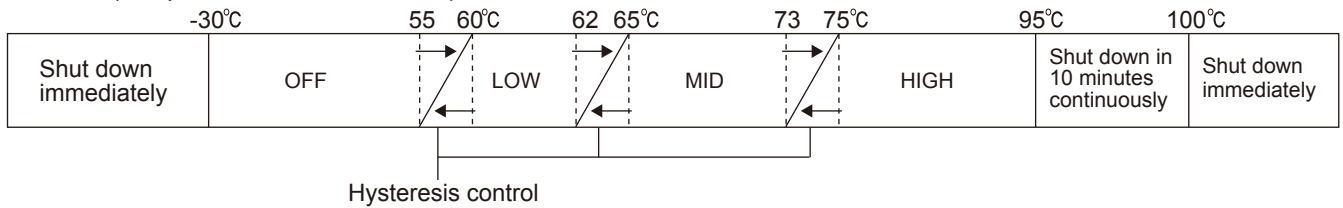

VOLH(Voltage of VOLH port)

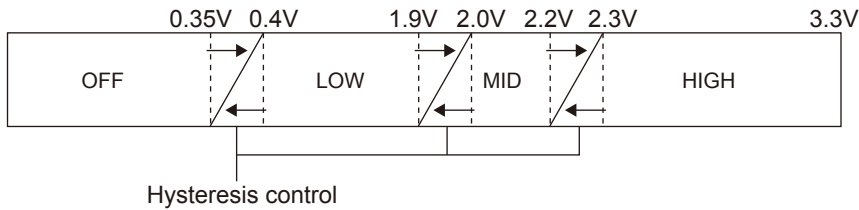

How to check

- How to check Cooling Fan.
See 1-12 in "OPERATION CHECK-2".
- How to check the value of THERMAL and VOLH.
See 1-7 in "OPERATION CHECK-1".

EXPLODED VIEWS-2

* WiFi & Bluetooth Module has already been certificated by FCC and IC.

Information to the user.

Indicate "Contains FCC ID: TX2-RTL8273AS", "Contains IC: 6317A- RTL8273AS" and following information to the host device installed.

This device complies with part 15 of the FCC Rules. Operation is subject to the following two conditions: (1) This device may not cause harmful interference, and (2) this device must accept any interference received, including interference that may cause undesired operation.

Describe the following sentence to a user's manual of the host device.

[For FCC]

FCC CAUTION

Changes or modifications not expressly approved by the party responsible for compliance could void the user's authority to operate the equipment.

Note: This equipment has been tested and found to comply with the limits for a Class B digital device, pursuant to part 15 of the FCC Rules. These limits are designed to provide reasonable protection against harmful interference in a residential installation. This equipment generates, uses and can radiate radio frequency energy and, if not installed and used in accordance with the instructions, may cause harmful interference to radio communications. However, there is no guarantee that interference will not occur in a particular installation. If this equipment does cause harmful interference to radio or television reception, which can be determined by turning the equipment off and on, the user is encouraged to try to correct the interference by one or more of the following measures:

- Reorient or relocate the receiving antenna.
- Increase the separation between the equipment and receiver.
- Connect the equipment into an outlet on a circuit different from that to which the receiver is connected.
- Consult the dealer or an experienced radio/TV technician for help.

This transmitter must not be co-located or operated in conjunction with any other antenna or transmitter.

This equipment complies with FCC radiation exposure limits set forth for an uncontrolled environment and meets the FCC radio frequency (RF) Exposure Guidelines in Supplement C to OET65. This equipment has very low levels of RF energy that it deemed to comply without maximum permissive exposure evaluation (MPE). But it is desirable that it should be installed and operated keeping the radiator at least 20cm or more away from person's body (excluding extremities: hands, wrists, feet and ankles).

[For IC]

This Class B digital apparatus complies with Canadian ICES-003.

Cet appareil numérique de la classe B est conforme à la norme NMB-003 du Canada.

This device complies with Industry Canada licence-exempt RSS standard(s). Operation is subject to the following two conditions: (1) this device may not cause interference, and (2) this device must accept any interference, including interference that may cause undesired operation of the device.

Le présent appareil est conforme aux CNR d'Industrie Canada applicables aux appareils radio exempts de licence. L'exploitation est autorisée aux deux conditions suivantes : (1) l'appareil ne doit pas produire de brouillage, et (2) l'utilisateur de l'appareil doit accepter tout brouillage radioélectrique subi, même si le brouillage est susceptible d'en compromettre le fonctionnement.

This equipment complies with IC radiation exposure limits set forth for an uncontrolled environment and meets RSS-102 of the IC radio frequency (RF) Exposure rules. This equipment has very low levels of RF energy that it deemed to comply without maximum permissive exposure evaluation (MPE). But it is desirable that it should be installed and operated keeping the radiator at least 20cm or more away from person's body (excluding extremities: hands, wrists, feet and ankles).

Cet équipement est conforme aux limites d'exposition aux rayonnements énoncées pour un environnement non contrôlé et respecte les règles d'exposition aux fréquences radioélectriques (RF) CNR-102 de l'IC. Cet équipement émet une énergie RF très faible qui est considérée conforme sans évaluation de l'exposition maximale autorisée. Cependant, cet équipement doit être installé et utilisé en gardant une distance de 20 cm ou plus entre le dispositif rayonnant et le corps (à l'exception des extrémités : mains, poignets, pieds et chevilles).

SCHEMATIC DIAGRAMS-02(PART-2)
BLOCK DIAGRAM VIDEO SECTION

Model No. TX-NR525/626/727/828,DTR-30.5/40.5/50.5,HT-RC550/560

SCHEMATIC DIAGRAM (PART-2) BLOCK DIAGRAM(VIDEO)

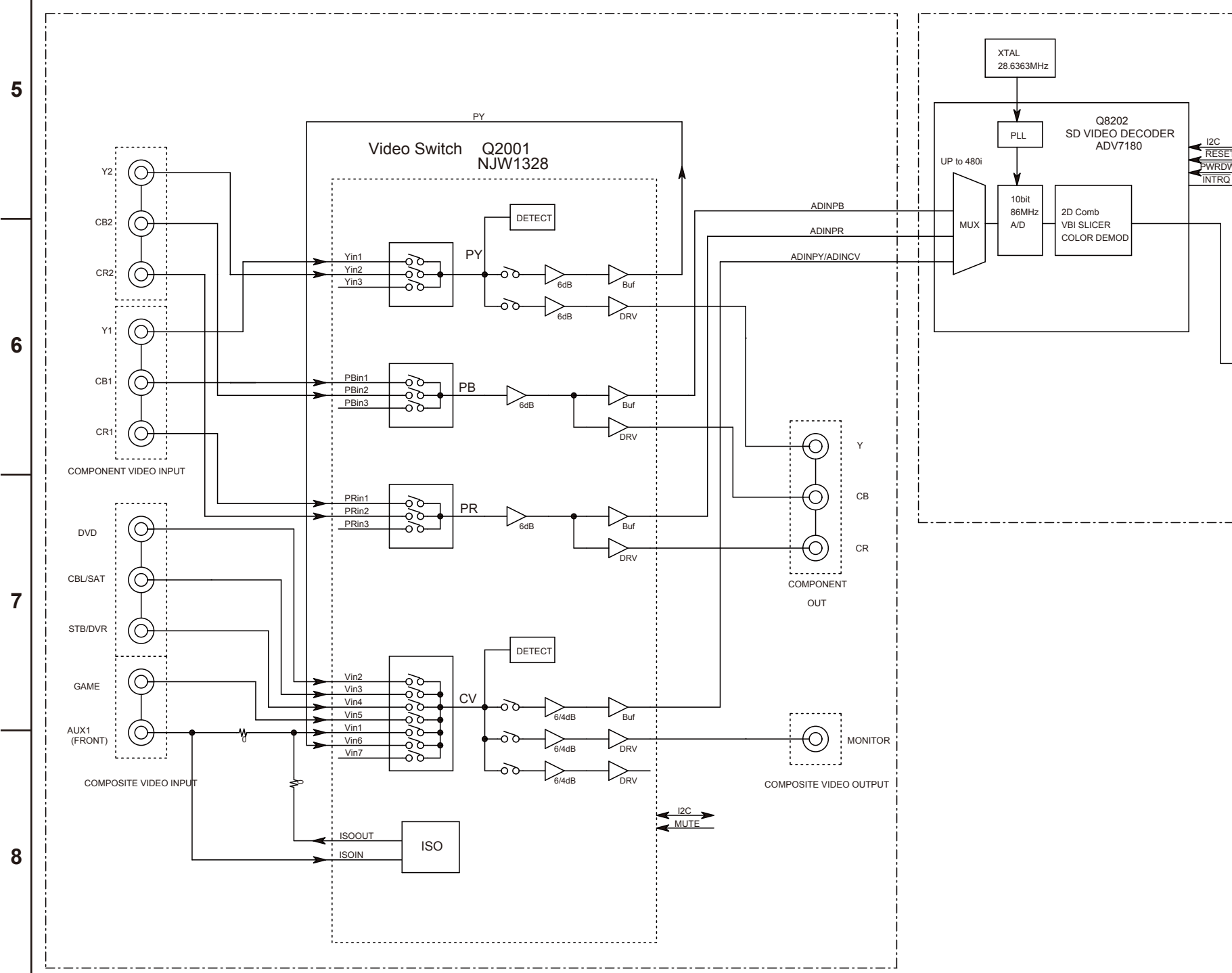
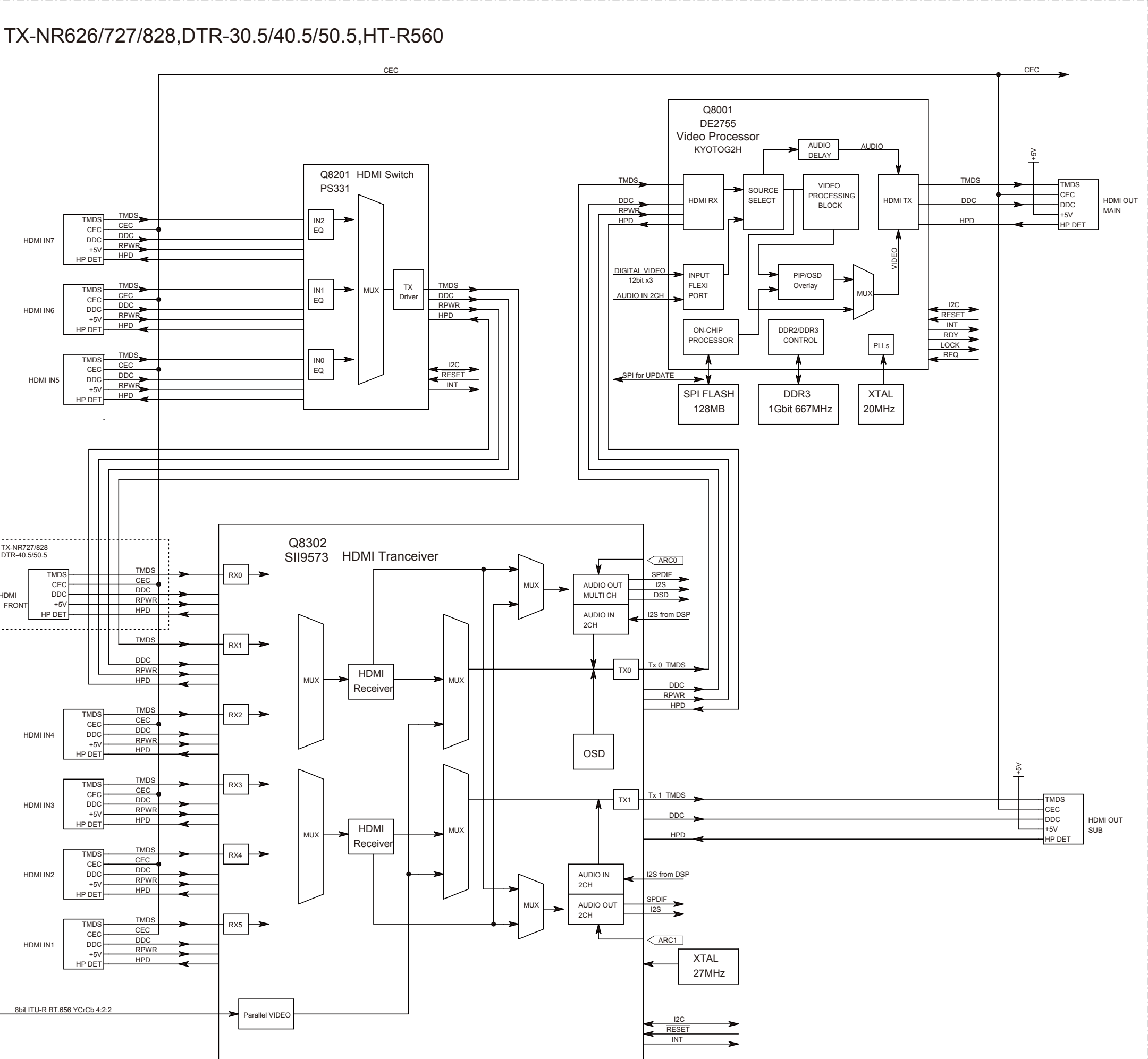
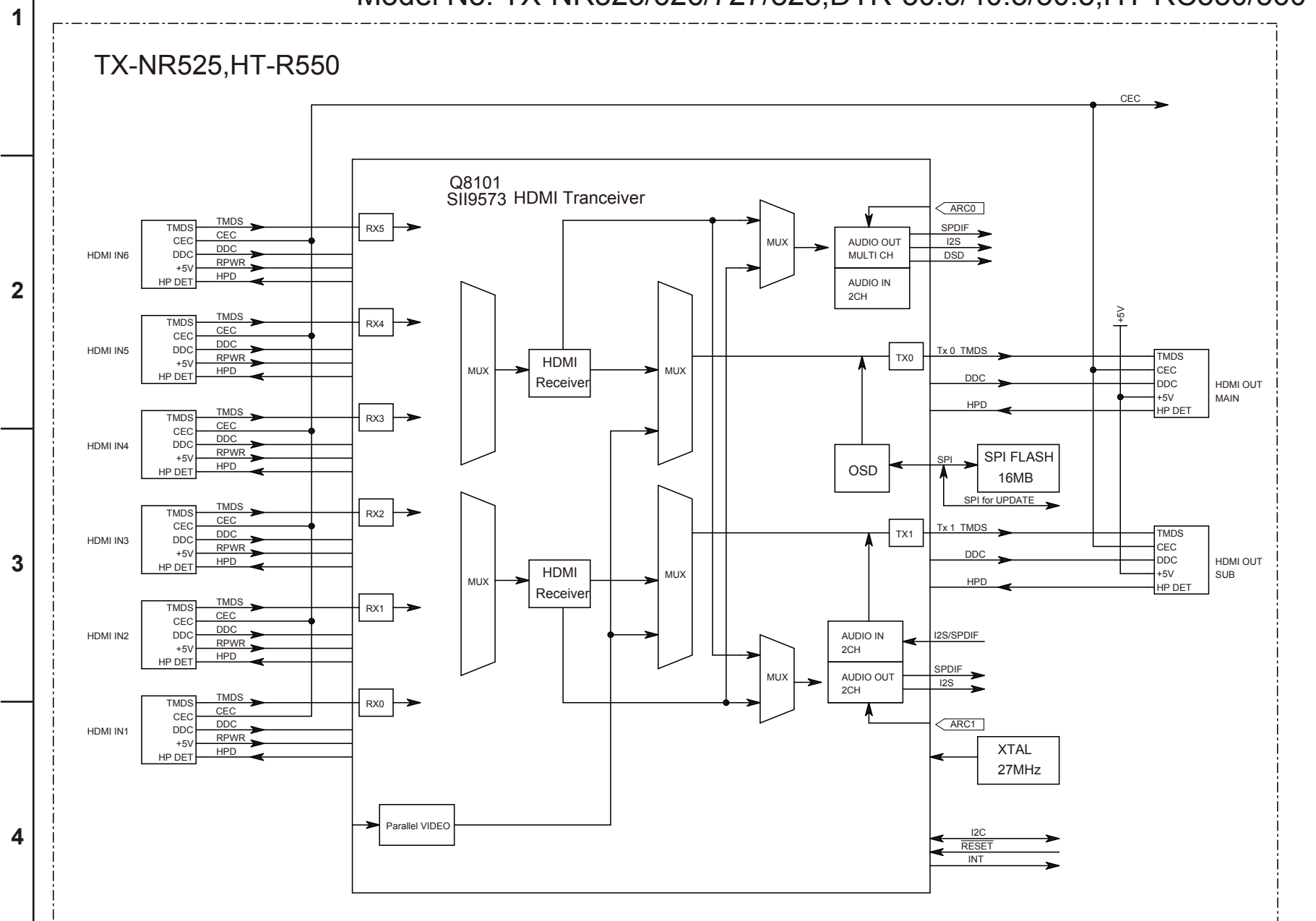

SCHEMATIC DIAGRAMS-05(PART-5)
AMP SECTION

	MODEL
T7	TX-NR727
T8	TX-NR828
D4	DTR-40.5
D5	DTR-50.5

U0010
AUDIO(AMP/ASP) PC BOARD

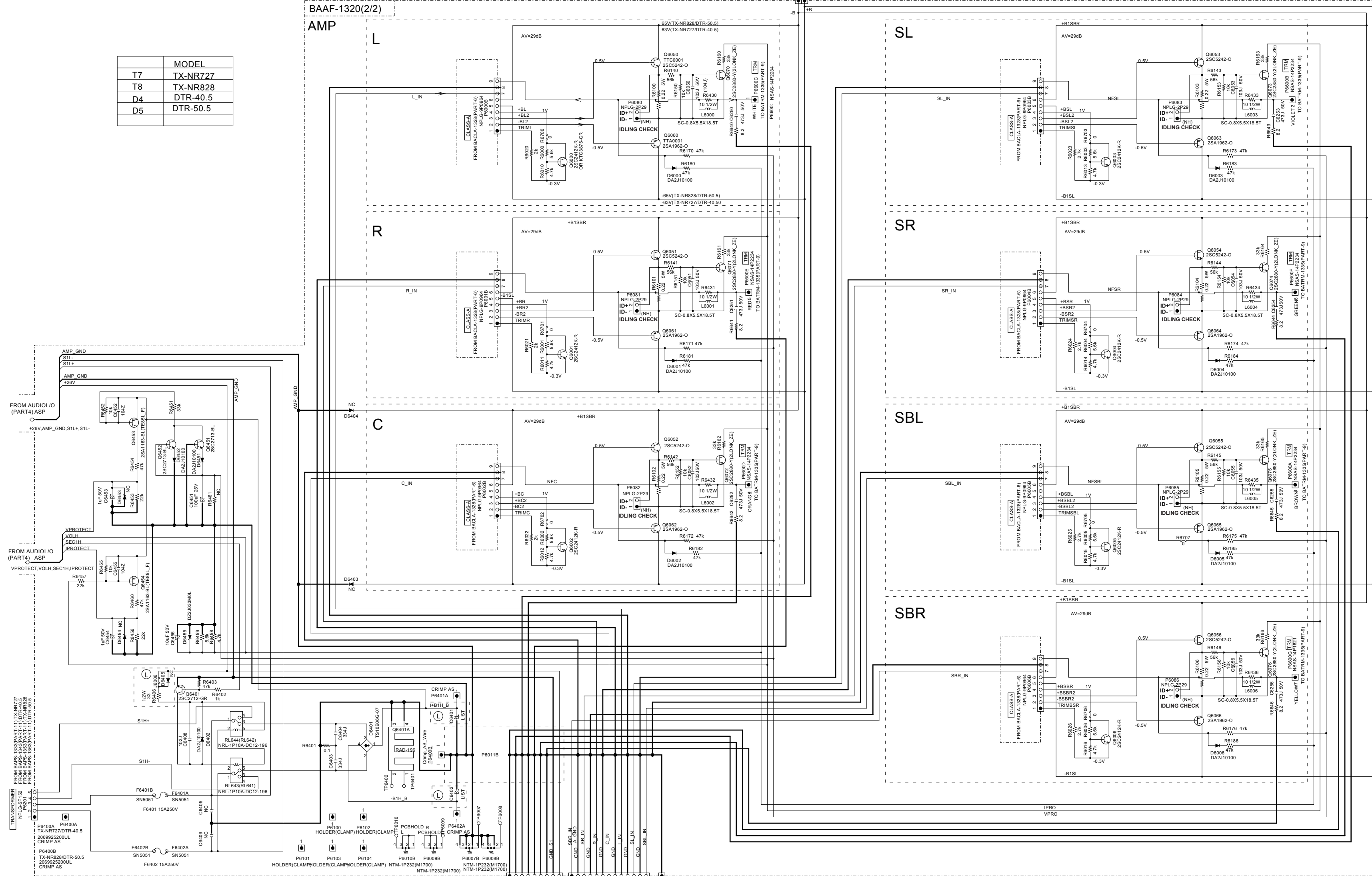
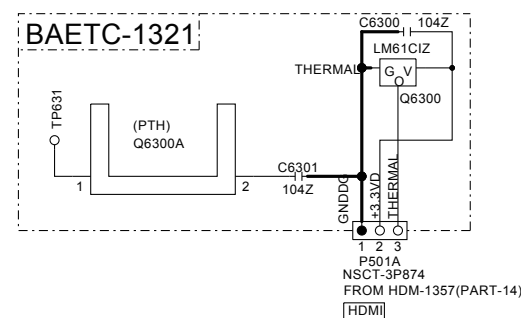
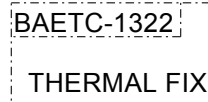

Table I	T7/D4	T8/D5
C6401/C6402	1200uF 71V	1500uF 75V
R6406	33 (1W)	68 (1W)
J606	0	0

U0011
THERMAL SENSOR PC BOARD



U0012
FIX(SENSOR) PC BOARD



U0013 <Note>Except TX-NR727
POWER SUPPLY(-VP) PC BOARD

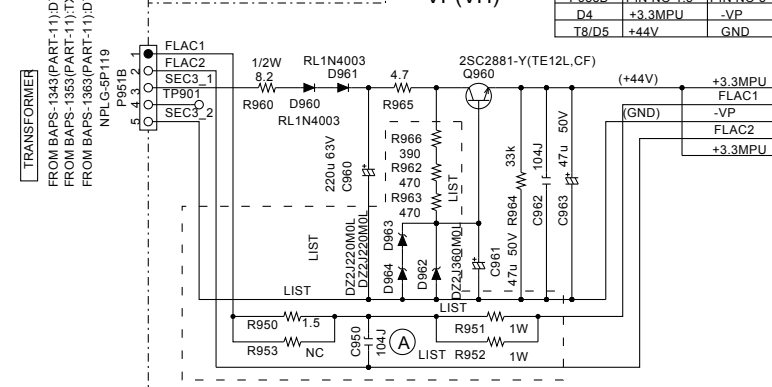

Table A	T8(TX-NR828)	D4(DTR-40.5)	D5(DTR-50.5)	MODEL		
R900	1	1	1.5	1.5	T7	TX-NR727
R953	X	X	X	X	T8	TX-NR828
R951	10(1W)	10(1W)	33(1W)	33(1W)	D4	DTR-40.5
R952	15(1W)	15(1W)	33(1W)	33(1W)	D5	DTR-50.5
R956	470	470	2.2k	2.2k	470	470
R963	470	470	3.3k	3.3k	470	470
R966	390	390	390	390	390	390
D962	X	X	0	0	X	X
D963/D964	0	0	X	X	0	0

SCHEMATIC DIAGRAMS-06(PART-6)

AMP CLASS-A SECTION

1

ADJUSTMENT OF IDLING CURRENT

[NOTES]

- Set R5440-5442 and 6043-6046 to minimum position before POWER ON.
- Equip series 1/4W 100-ohm resistors near the terminal respectively in the each poles of the jig used for P6080 - 6086 terminals.

[PROCEDURES]

- Set the voltages at P6080 - 6082 to **6.0 mV** by adjusting R5440 - 5442, under the condition of no input and no load, immediately after POWER ON.
 - Set the voltages at P6083 - 6086 to **4.0 mV** by adjusting R6043 - 6046, under the condition of no input and no load, immediately after POWER ON.
- c. Re-adjust by following procedure after 5 minutes of heat running.

L/ C/ R	
Below 9 mV	→ 9 mV
Between 9 - 11 mV	→ Leave it as it is.
Over 11 mV	→ 11mV

SL/ SR/ SBL(SW)/ SBR	
Below 6 mV	→ 6 mV
Between 6 - 8 mV	→ Leave it as it is.
Over 8 mV	→ 8 mV

2

BACLA-1328 CLASS-A

U0030 AMP(CLASS A) PC BOARD

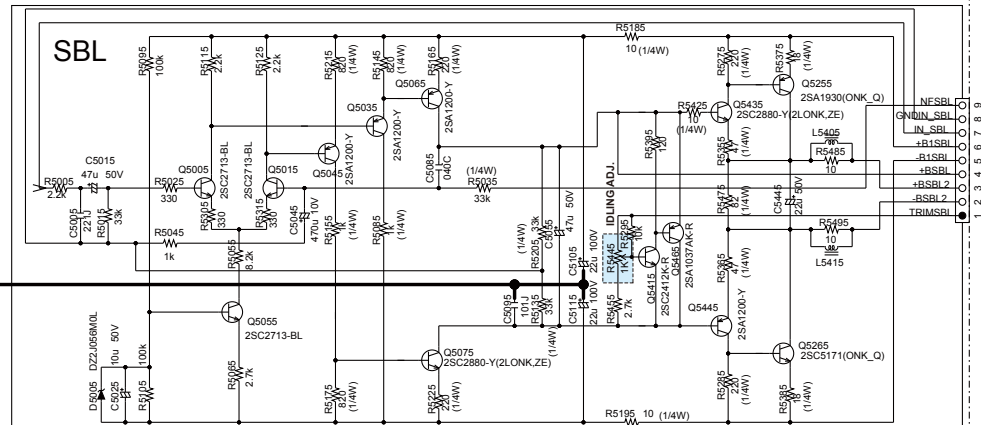
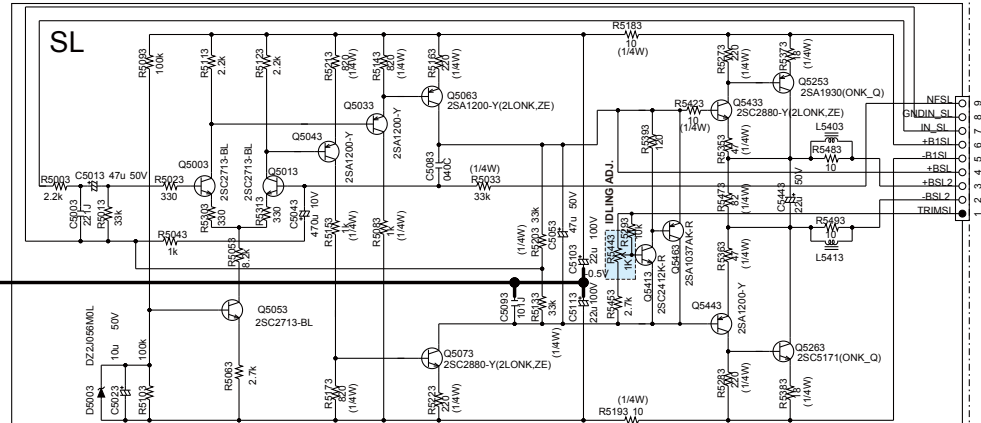
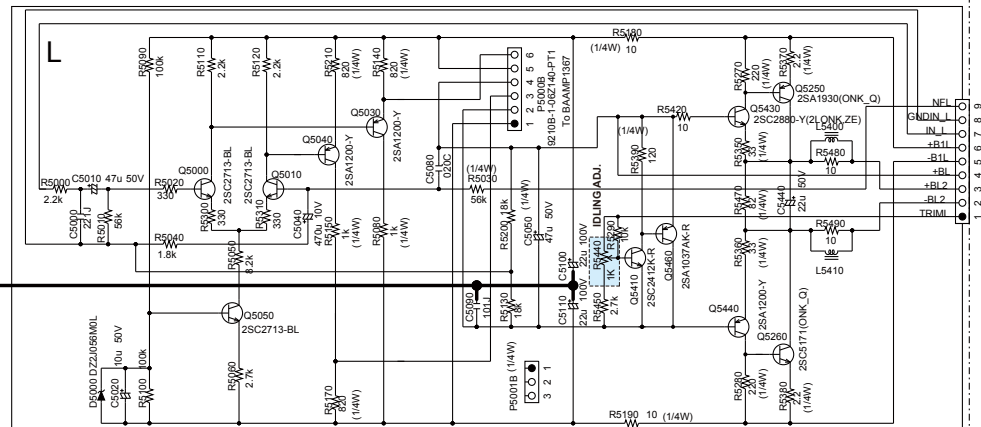

3

BAAMP-1367

U0020 TRANSISTOR PC BOARD

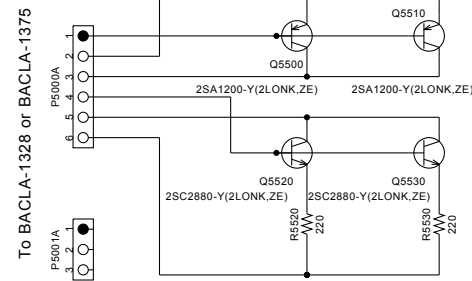

4

<NOTE>
This PCB ASS'Y is mounted 3pcs.

5

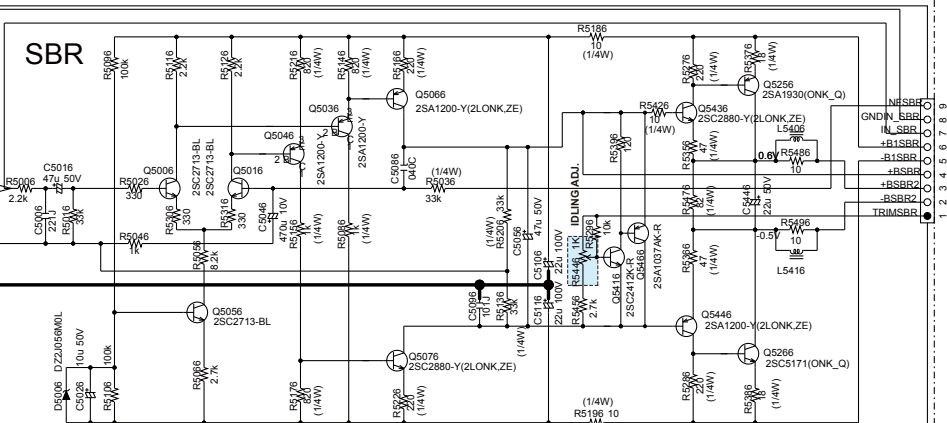
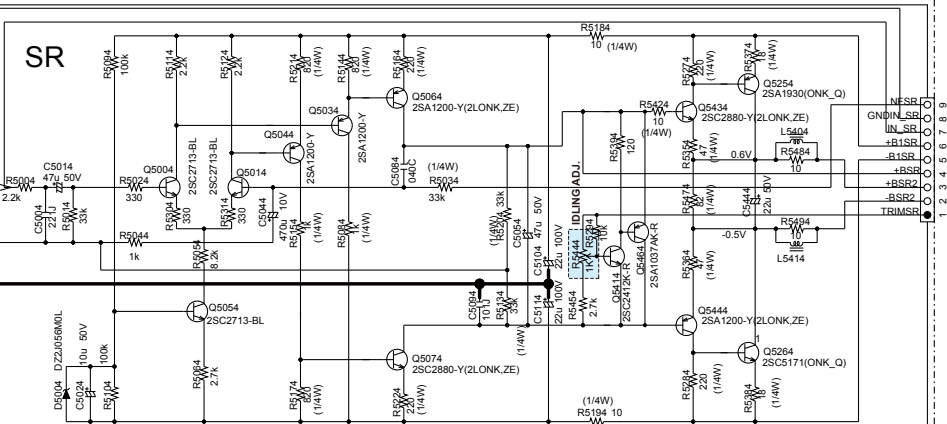
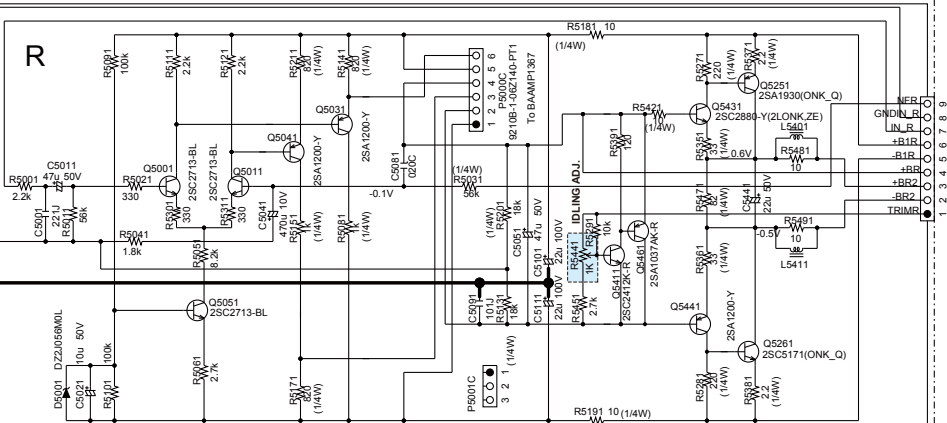
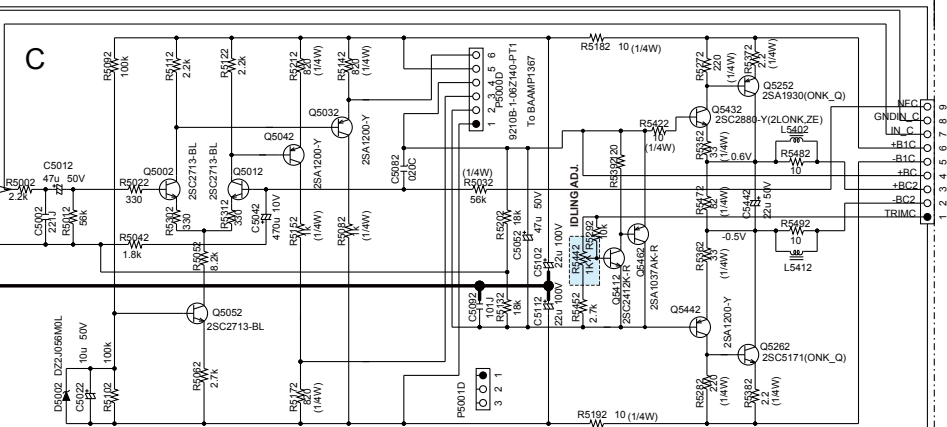

SCHEMATIC DIAGRAMS-07(PART-7)

DG(DAC LPF) SECTION

1

2

3

4

5

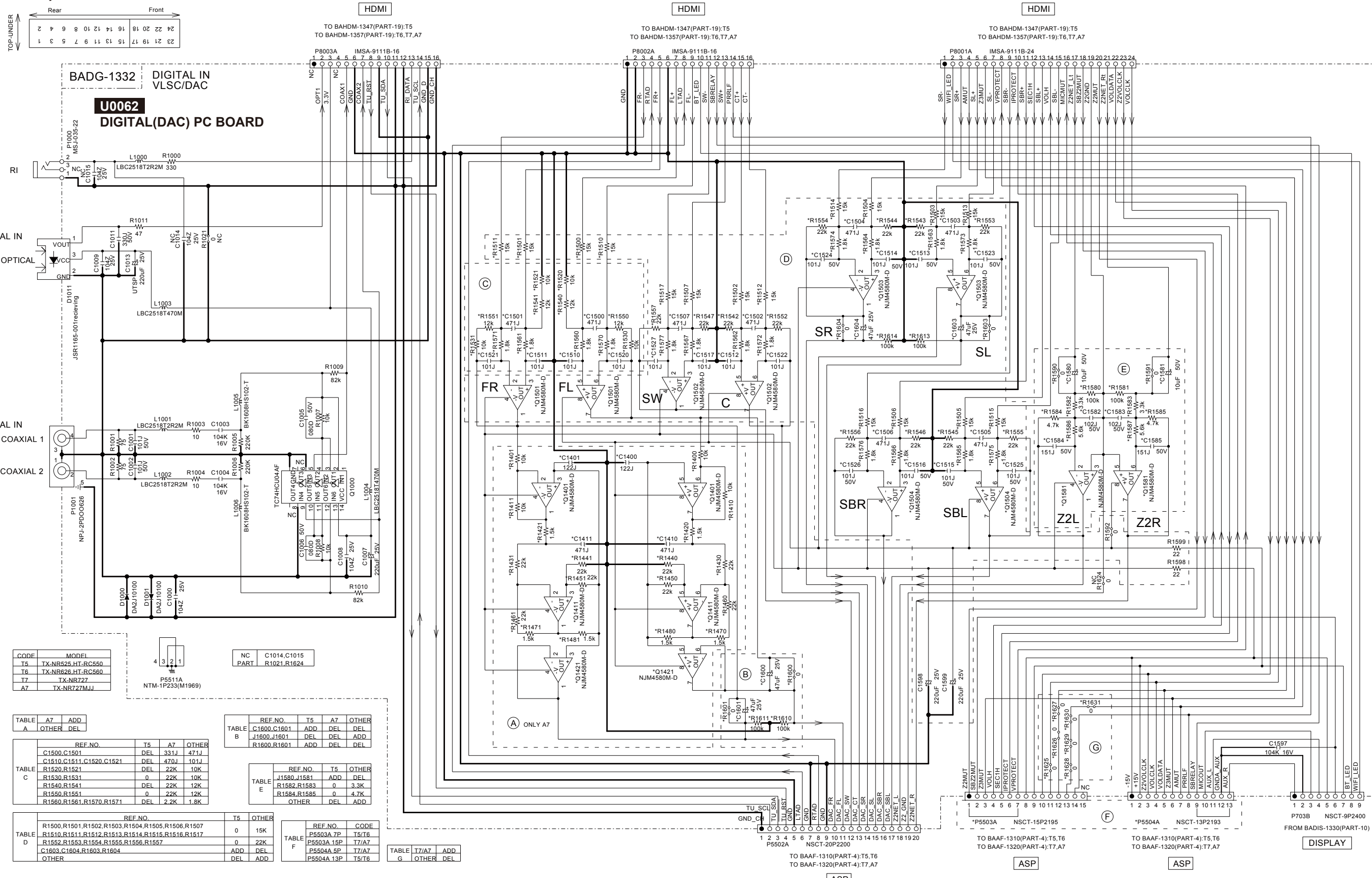

CODE	MODEL
T5	TX-NR525,HT-RC550
T6	TX-NR626,HT-RC560
T7	TX-NR727
A7	TX-NR727MJ

TABLE A	A7	ADD

TABLE C	REF. NO.	T5	A7	OTHER
	C1500,C1501	DEL	331J	471J
	C1510,C1511,C1520,C1521	DEL	470J	101J
	R1520,R1521	DEL	22K	10K
	R1530,R1531	0	22K	10K
	R1540,R1541	DEL	22K	12K
	R1550,R1551	0	22K	12K
	R1560,R1561,R1570,R1571	DEL	2.2K	1.8K

TABLE B	REF. NO.	T5	A7	OTHER
	C1600,C1601	ADD	DEL	DEL
	J1600,J1601	DEL	DEL	ADD
	R1600,R1601	ADD	DEL	DEL

TABLE E	REF. NO.	T5	OTHER
	J1580,J1581	ADD	DEL
	R1582,R1583	0	3.3K
	R1584,R1585	0	4.7K
	OTHER	DEL	ADD

TABLE D	REF. NO.	T5	OTHER
	R1500,R1501,R1502,R1503,R1504,R1505,R1506,R1507	0	15K
	R1510,R1511,R1512,R1513,R1514,R1515,R1516,R1517	0	22K
	R1552,R1553,R1554,R1555,R1556,R1557	ADD	DEL
	C1603,C1604,R1603,R1604	ADD	DEL
	OTHER	DEL	ADD

TABLE F	REF. NO.	CODE
	P5503A 7P	T5/T6
	P5503A 15P	T7/A7
	P5504A 5P	T7/A7
	P5504A 13P	T5/T6

TABLE G	T7/A7	ADD
		DEL

SCHEMATIC DIAGRAMS-08(PART-8)
VIDEO SECTION

1

2

3

4

5

COMPONENT
IN 2
PB
Y
IN 1
PB
Y
OUT
PB
Y
COMPOSITE
IN 5
OUT
COMPOSITE
IN 4
IN 3
IN 2

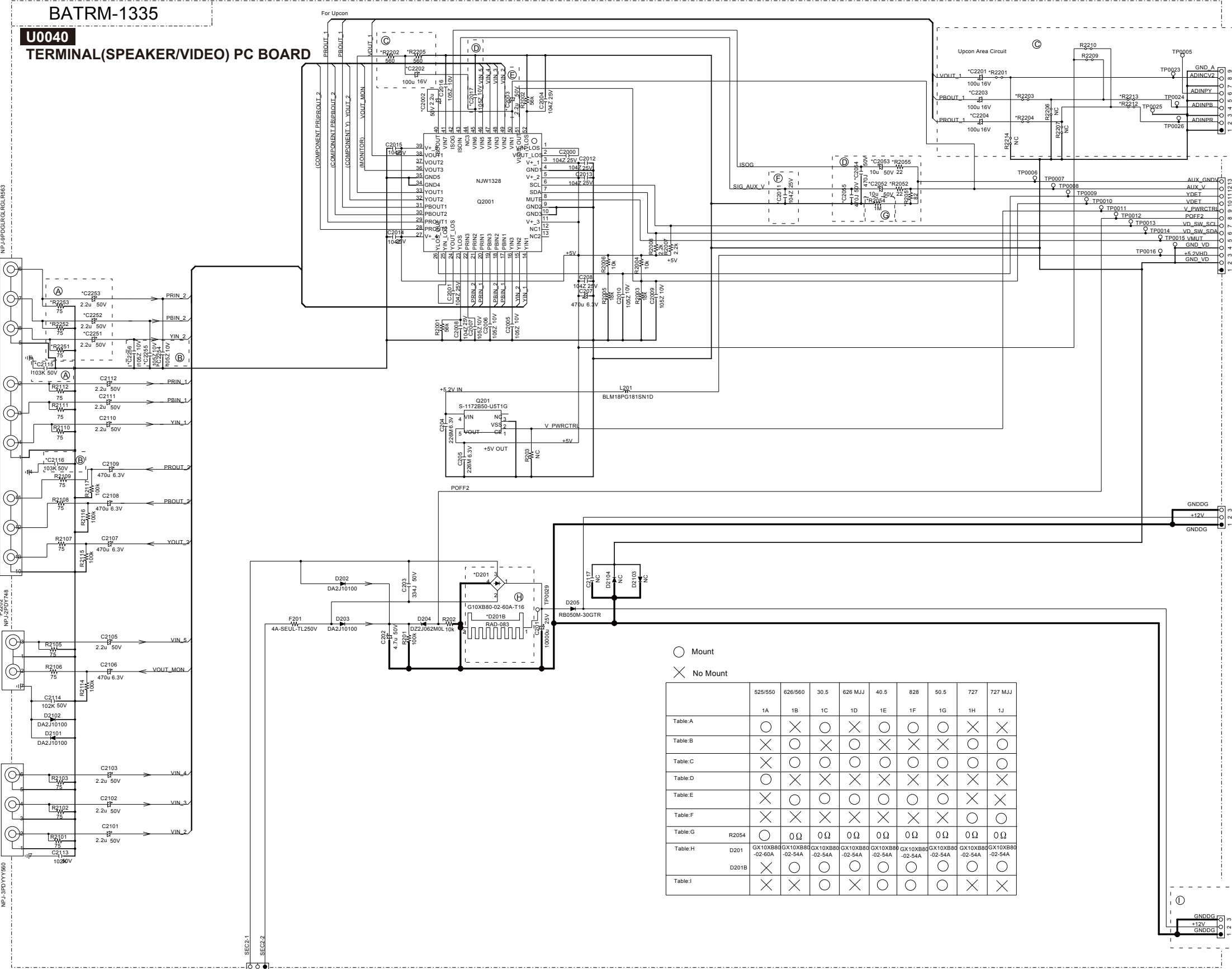

○ Mount
× No Mount

	525/550	626/560	30.5	626 MJJ	40.5	828	50.5	727	727 MJJ
Table:A	○	×	○	×	○	○	○	×	×
Table:B	×	○	×	○	×	×	×	○	○
Table:C	×	○	○	○	○	○	○	○	○
Table:D	×	×	×	×	×	×	×	×	×
Table:E	×	○	○	○	○	○	○	×	×
Table:F	×	×	×	×	×	×	×	○	○
Table:G	R2054	○	○	○	○	○	○	○	○
Table:H	D201	GX10XB80-02-60A	GX10XB80-02-54A	GX10XB80-02-54A	GX10XB80-02-54A	GX10XB80-02-54A	GX10XB80-02-54A	GX10XB80-02-54A	GX10XB80-02-54A
Table:I	D201B	×	○	○	○	○	○	○	○

TO BAETC-0645(PART-12)
(TX-NR626,727,828,HT-RC560,DTR-30.5,40.5,50.5)

To RS232/12VTRG/IR

BAHDM-1347(PART-14)
(TX-NR525,HT-RC550)

BAHDM-1357(PART-15)
(TX-NR626,727,828,HT-RC560,DTR-30.5,40.5,50.5)

BAHDM-1347(PART-14)
(TX-NR525,HT-RC550)

BAHDM-1357(PART-15)
(TX-NR626,727,828,HT-RC560,DTR-30.5,40.5,50.5)

BAHDM-1357(PART-17)
(TX-NR626,727,828,HT-RC560,DTR-30.5,40.5,50.5)

TO HDMI

TO HDMI

TO HDMI

FROM TRANS

SCHEMATIC DIAGRAMS-09(PART-9)
SPEAKER OUT SECTION

1

2

3

4

5

TO AMP

BAAF-1310(PART-5)
(TX-NR525,626,HT-RC550,560,DTR-30.5)

BAAF-1320(PART-5)
(TX-NR727,828,DTR-40.5,50.5)

FROM HDMI

BAHDM-1347(PART-14)
(TX-NR525,HT-RC560)

BAHDM-1357(PART-14)
(TX-NR626,727,828,HT-RC560,DTR-30.5,40.5,50.5)

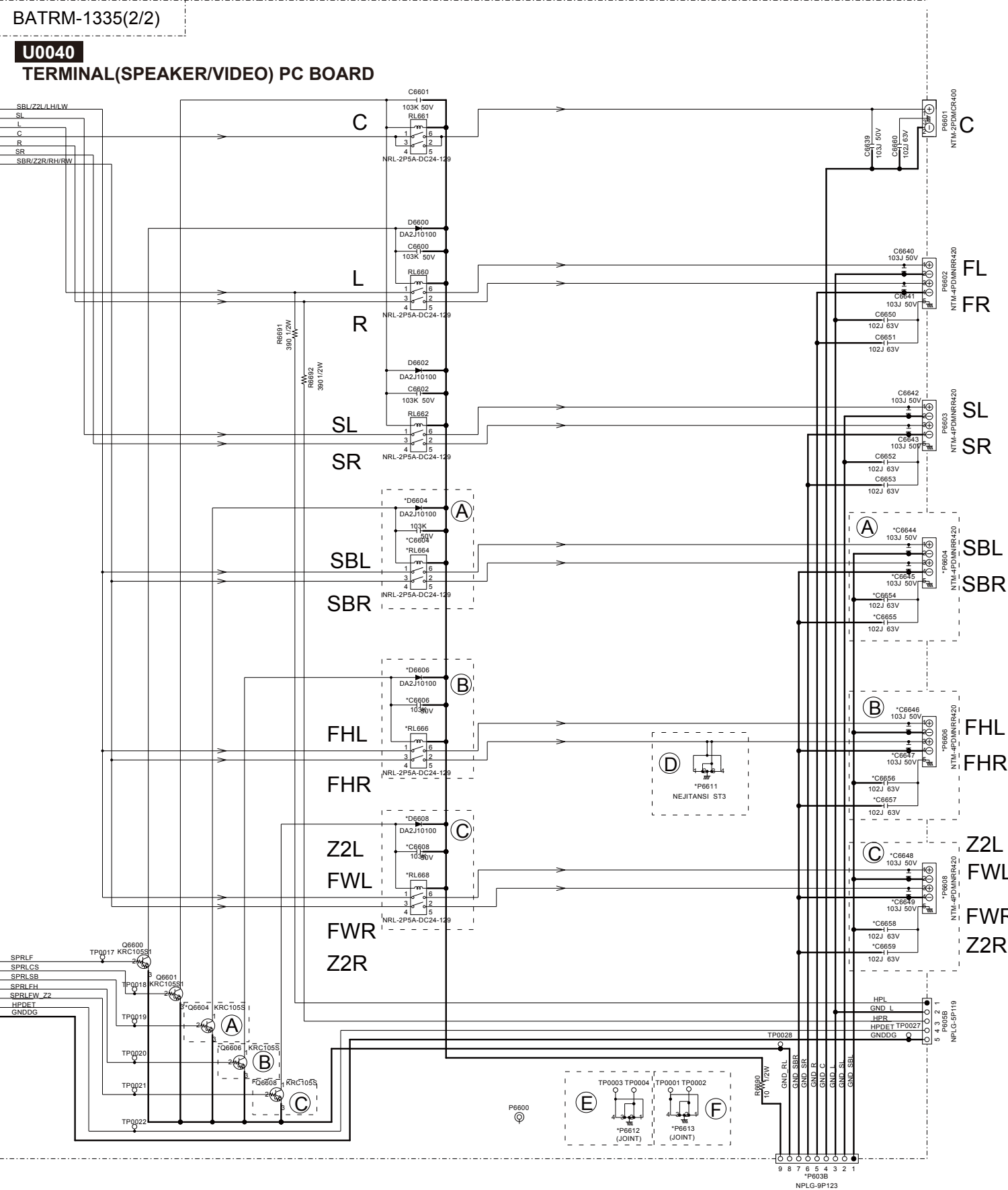

○ Mount
× No Mount

	525/550	626/560	30.5	626 MJJ	40.5	828	50.5	727	727 MJJ
Table:A	×	○	○	○	○	○	○	○	○
Table:B	×	×	×	×	×	○	○	×	×
Table:C	×	○	○	×	○	○	○	○	×
Table:D	○	×	×	○	×	×	×	×	○
Table:E	○	×	×	×	×	×	×	×	×
Table:F	×	○	○	○	○	○	○	○	○

BAETC-1334(PART-10)
(TX-NR525,626,727,HT-RC550,560)

BAETC-1344(PART-10)
(DTR-30.5,40.5)

BAETC-1326(PART-10)
(TX-NR828)

BAETC-1364(PART-10)
(DTR-50.5)

TO HP

SCHEMATIC DIAGRAMS-10(PART-10)
DISPLAY SECTION

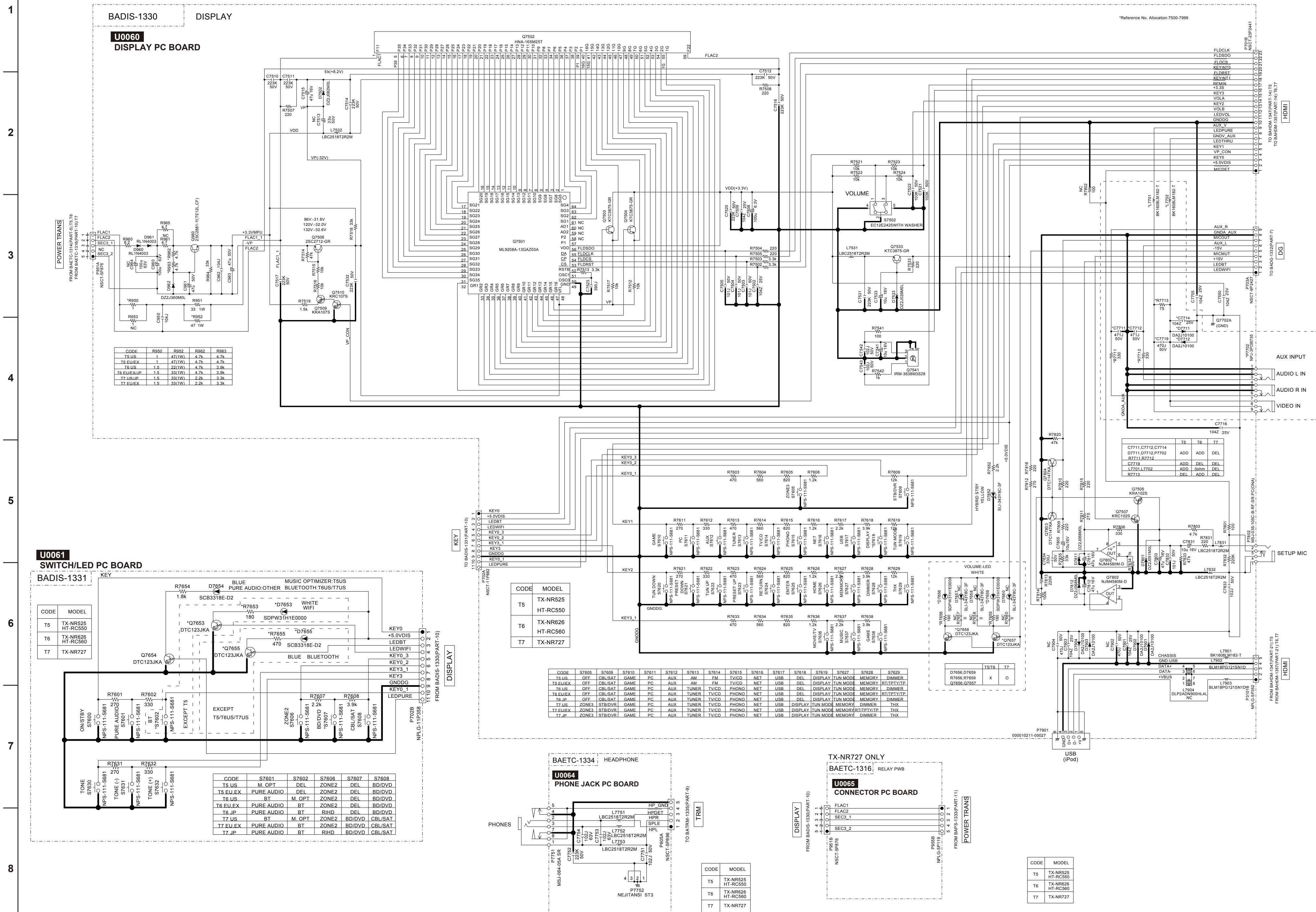

SCHEMATIC DIAGRAMS-13(PART-13)
FRONT HDMI SECTION

1

2

3

4

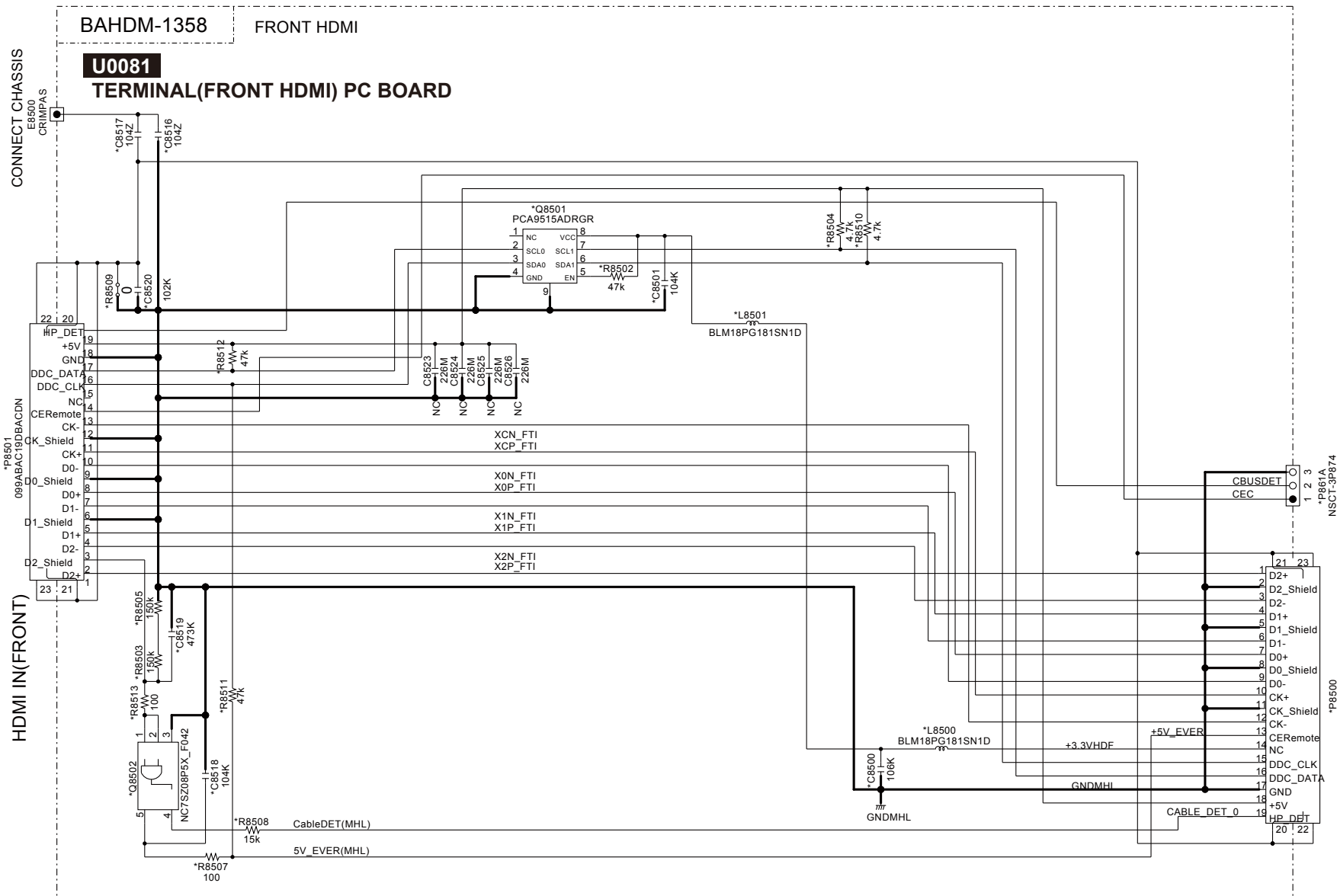

SCHEMATIC DIAGRAMS-14(PART-14) MPU SECTION

1
2
3
4
5
6
7
8

BAHDM-1357 (1/8)

U0080
HDMI PC BOARD

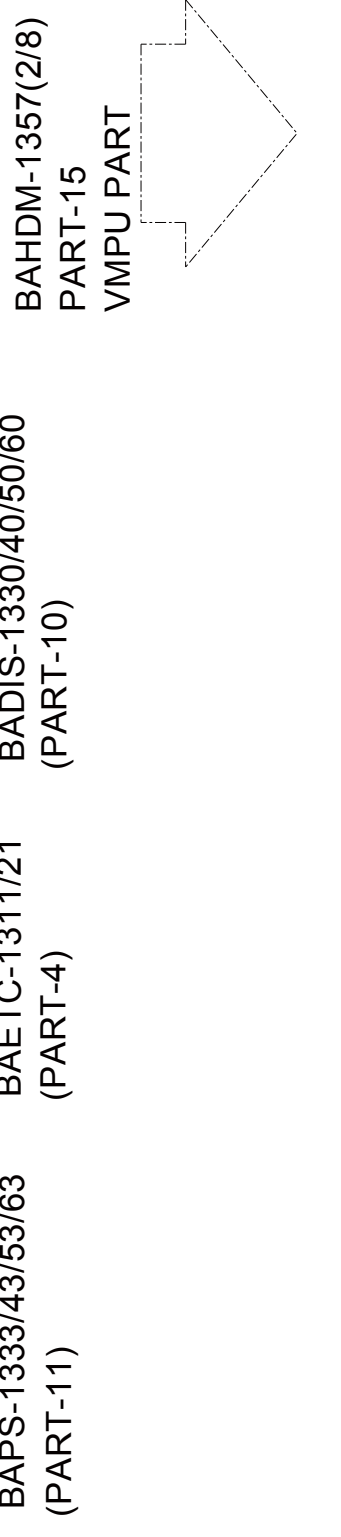
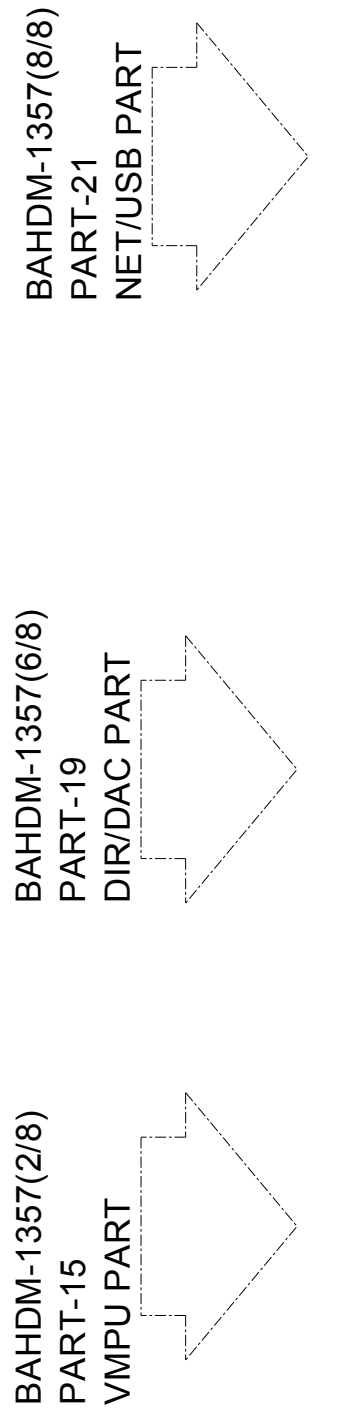
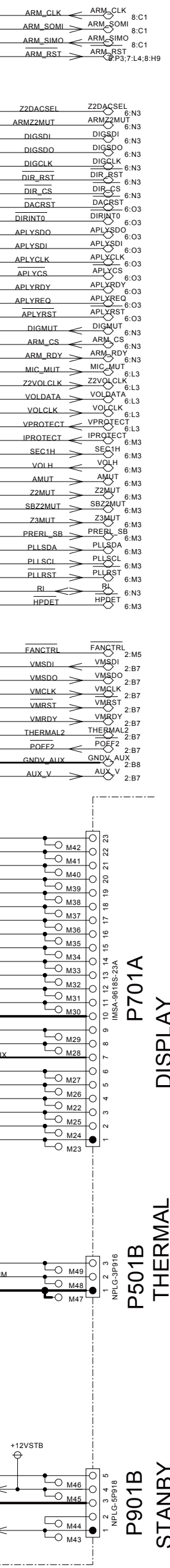
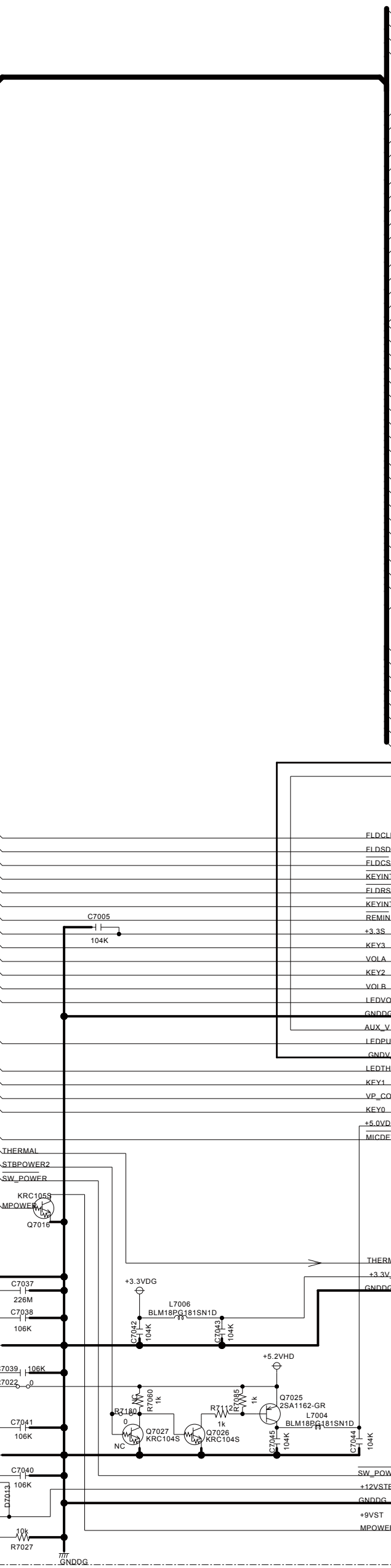
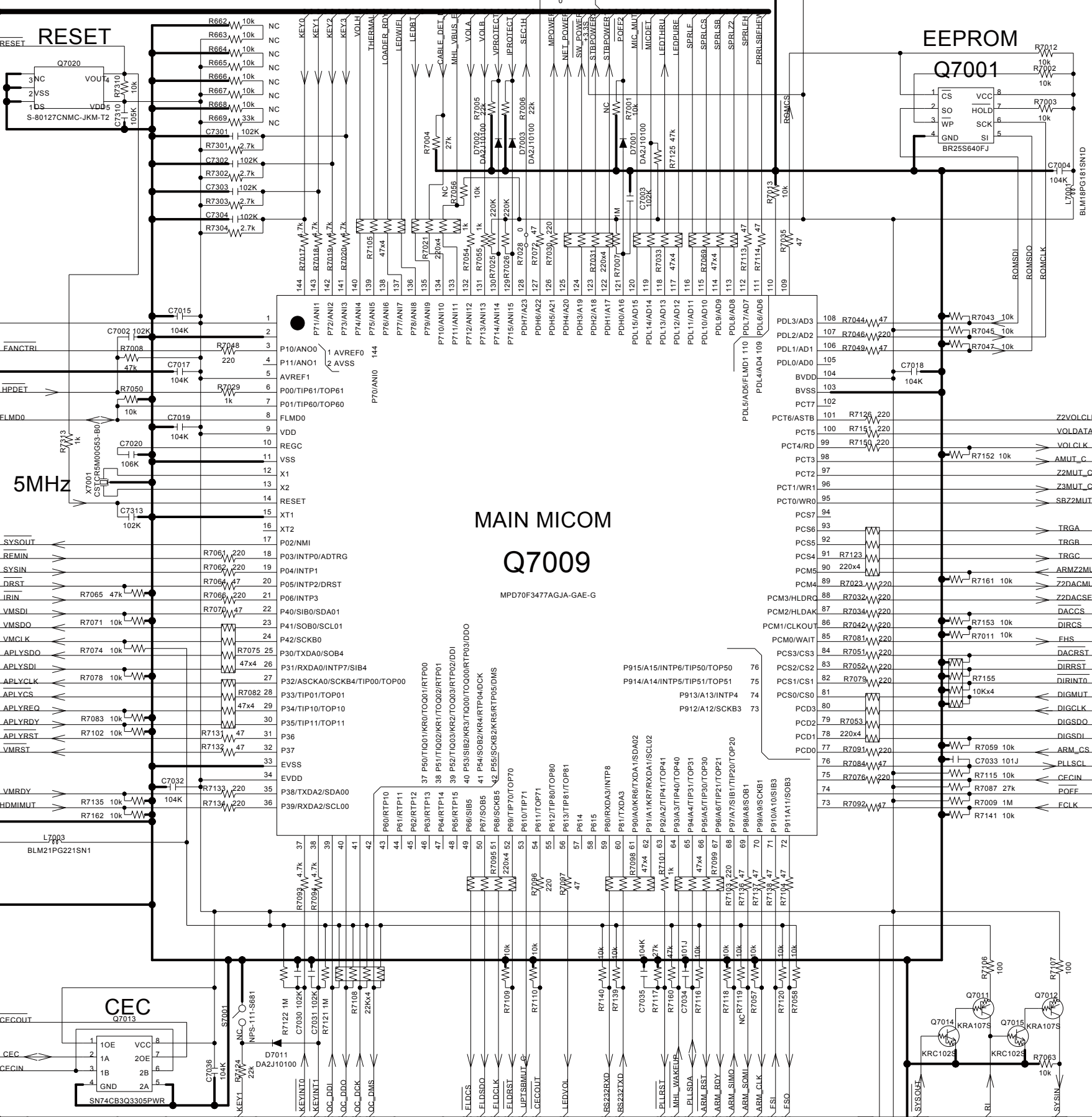
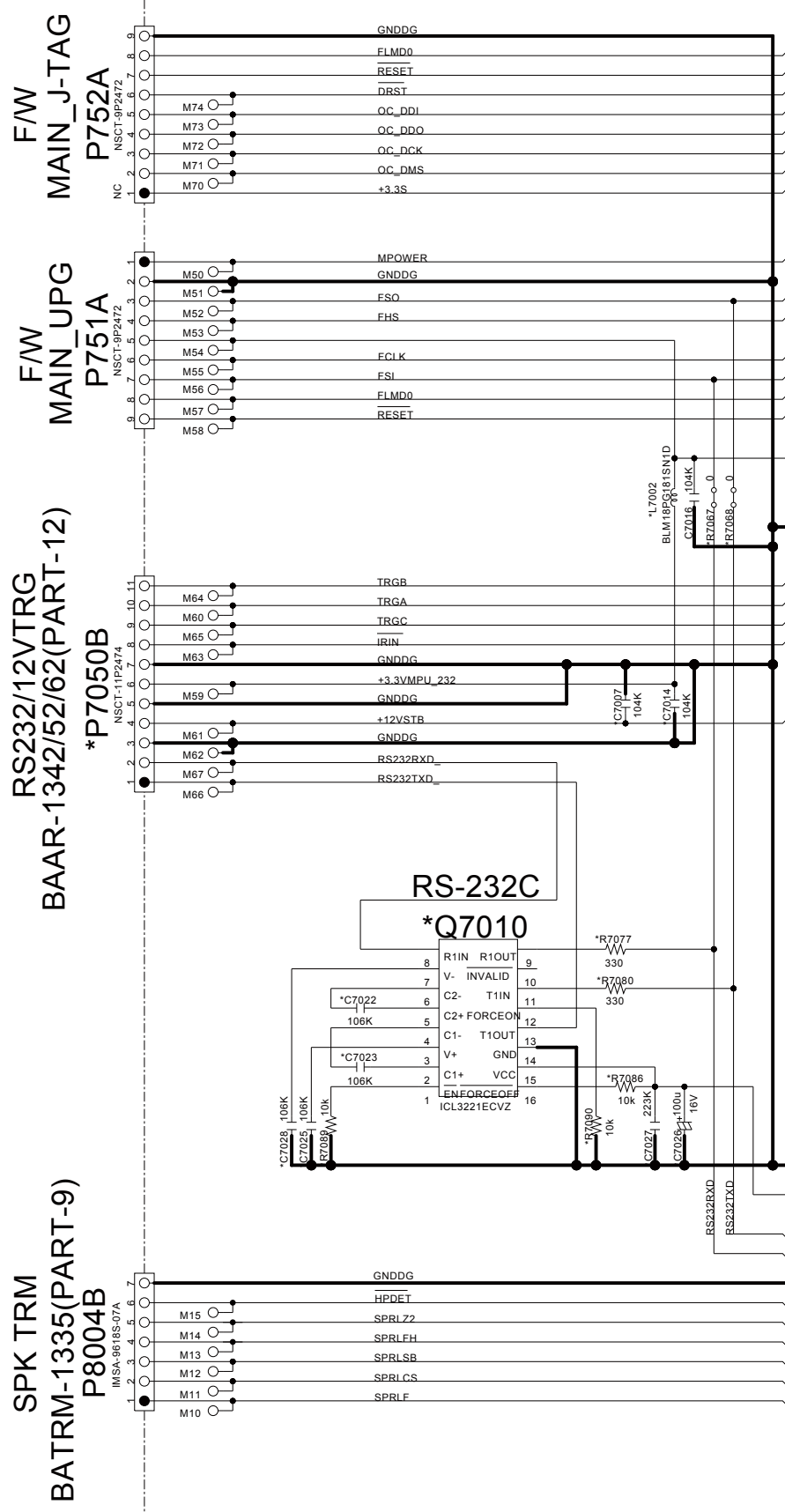

POWER SUPPLY(FOR STB)

SCHEMATIC DIAGRAMS-17(PART-17)
HDMI INPUT SECTION

1
2
3
4
5
6
7
8

BAHDM-1357(4/8)

U0080
HDMI PC BOARD

HDMI SW IN6-IN8

SD Video Decoder

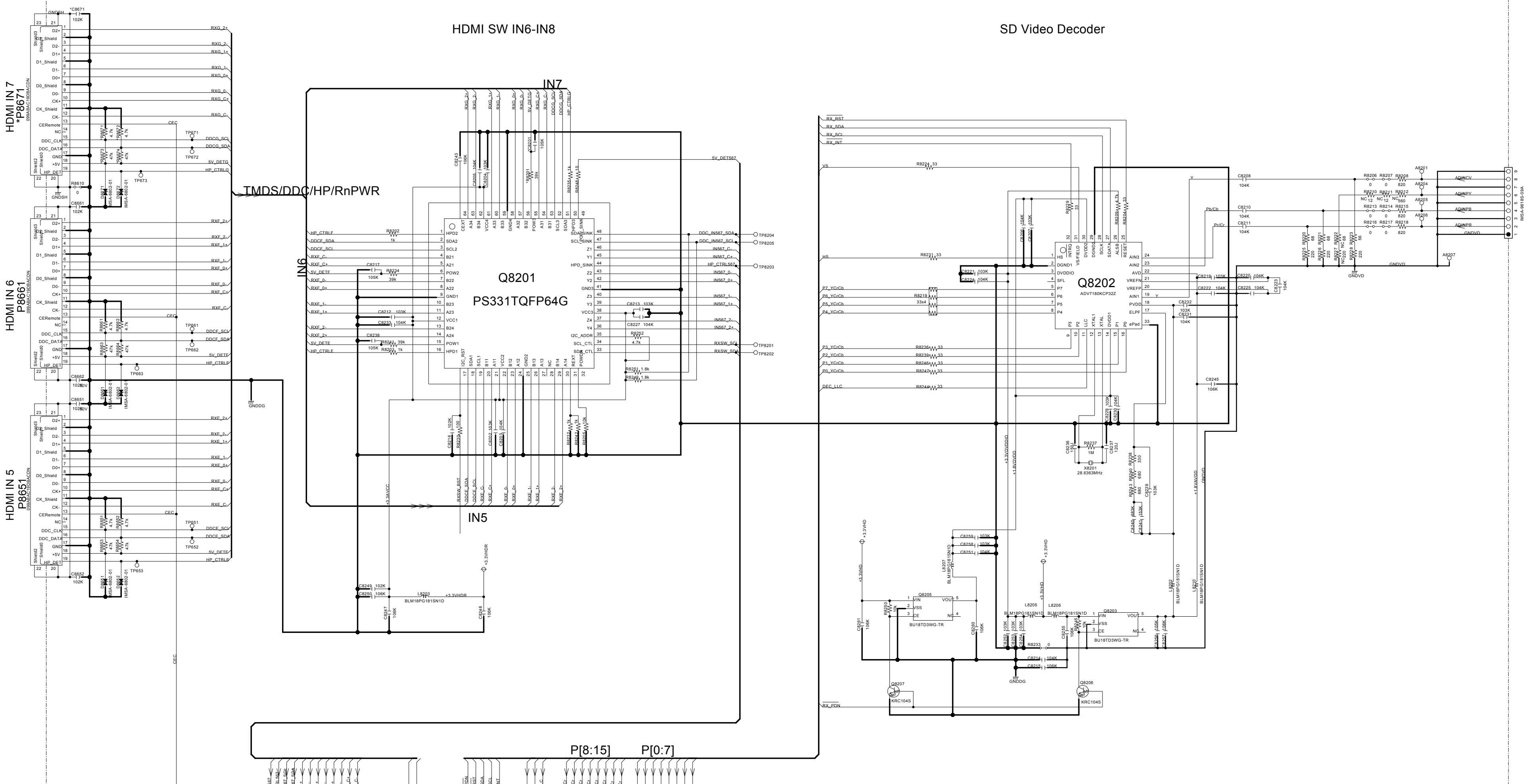

CEC

HDMI OUT
BAHDM-1357(3/8)
PART-16
HDMI PART

BAHDM-1357(2/8)
PART-15
VMPU PART

COMPONENT OUT
BAHDM-1357(3/8)
PART-16
HDMI PART

P2801B
COMPONENT UPCONVERSION
BA1RM-1335
(PART-17)

SCHEMATIC DIAGRAMS-18(PART-18)
VIDEO PROCESSOR SECTION

1
2
3
4
5
6
7
8

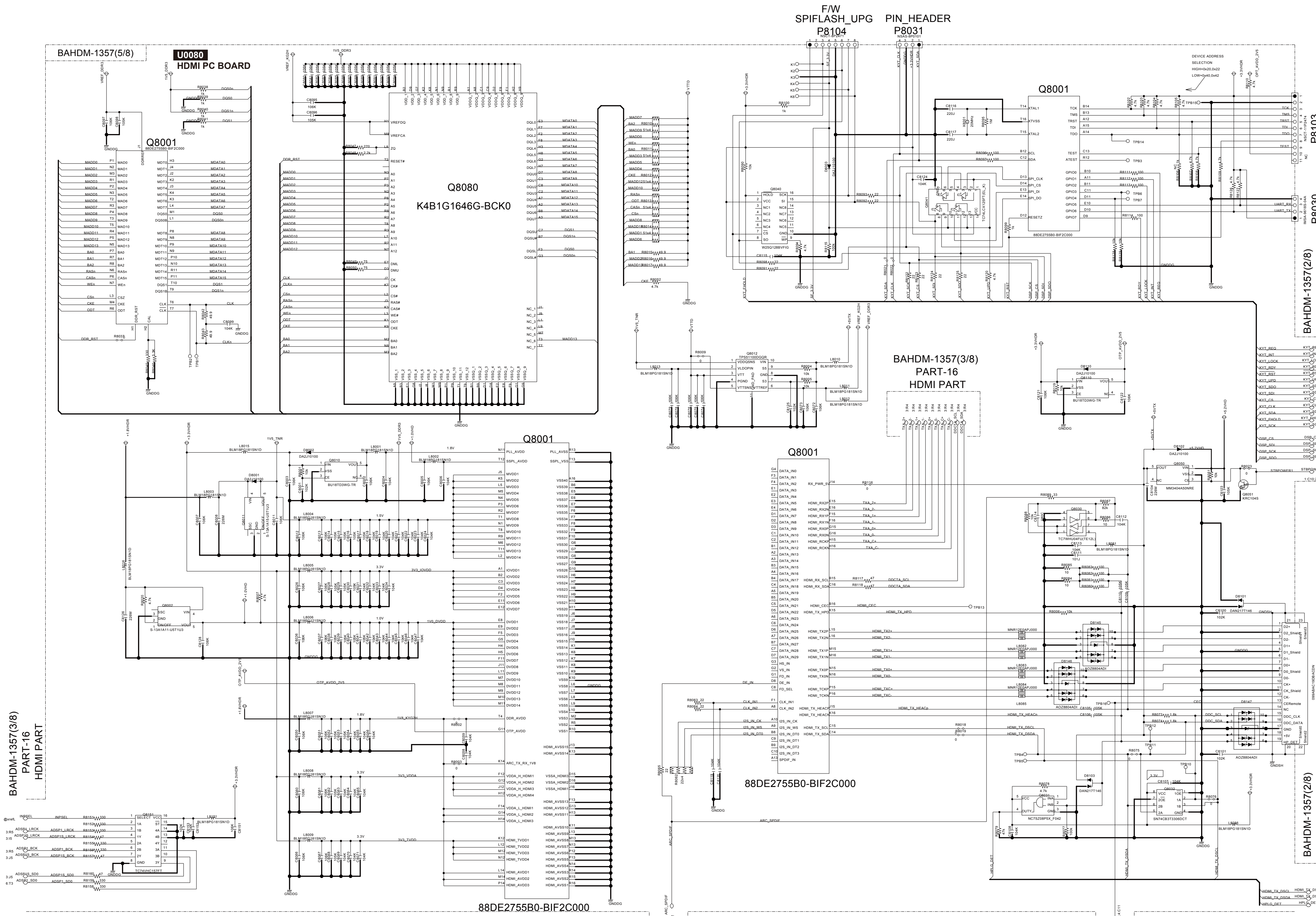

TO DIR/DAC SECTION
(PART-19)
BAHDM-1357(6/8)

CEC

P8103 F/W KG2H_DEBUG
P8030 F/W KG2H_LOG
BAHDM-1357(2/8) PART-15 VMPU PART
P8102 HDMI OUT MAIN

SCHEMATIC DIAGRAMS-19(PART-19)
DIR/DAC SECTION

1
2
3
4
5
6
7
8

BAHDM-1357(6/8)
U0080
HDMI PC BOARD

BADG-1332/45(PART-7)
DIGITAL IN
P8003B

BADG-1332/45(PART-7)
DIGITAL IN
P8002B

BADG-1332/45(PART-7)
DIGITAL IN
P8001B

PWB_FIX
P8005

BAHDM-1357(1/8)
PART-14
MPU PART

BAHDM-1357(5/8)
PART-18
VSP PART

BAHDM-1357(8/8)
PART-21
NET/USB PART

BAHDM-1357(7/8)
PART-20 PART

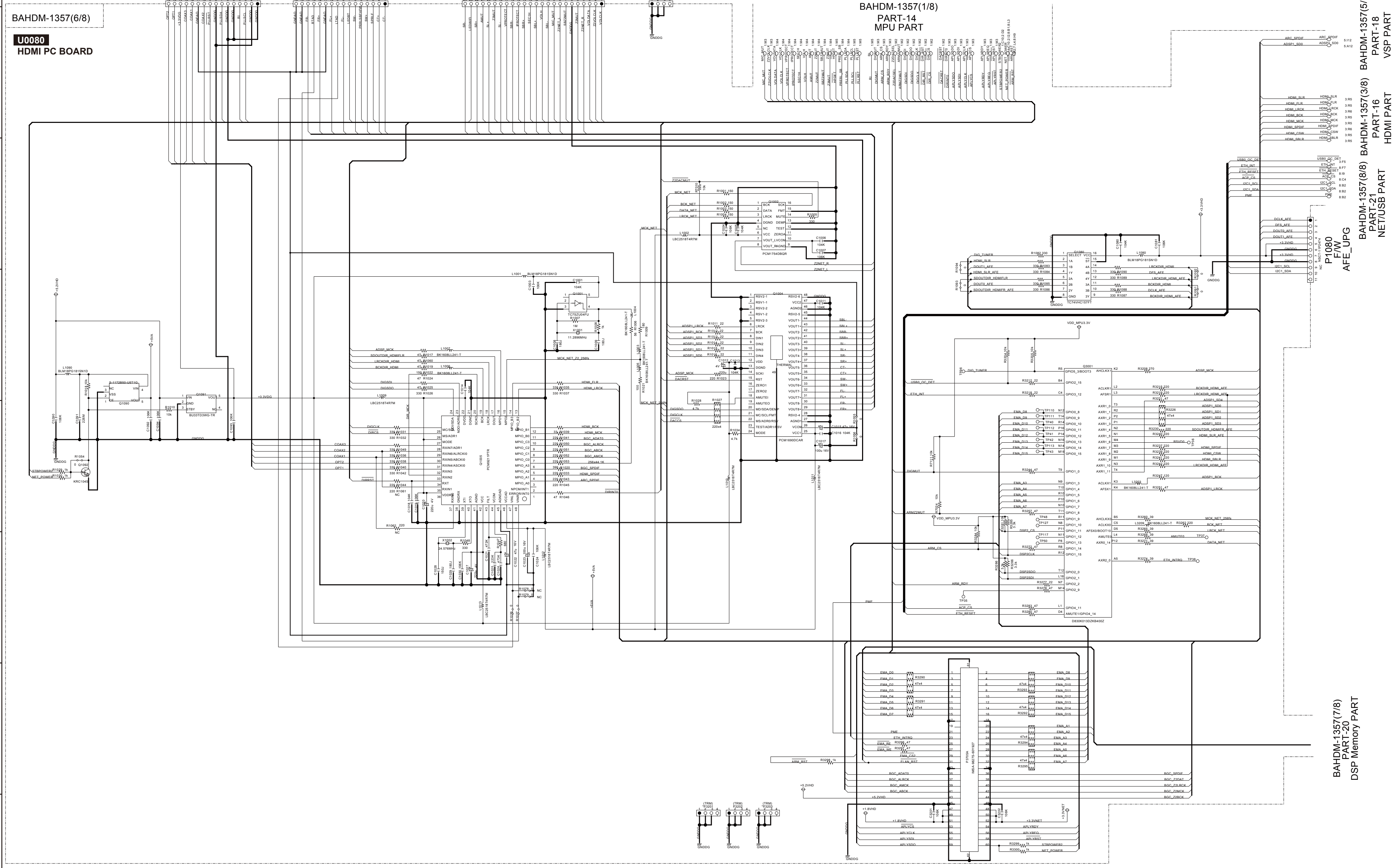

SCHEMATIC DIAGRAMS-20(PART-20)
DSP/Memory SECTION

1
2
3
4
5

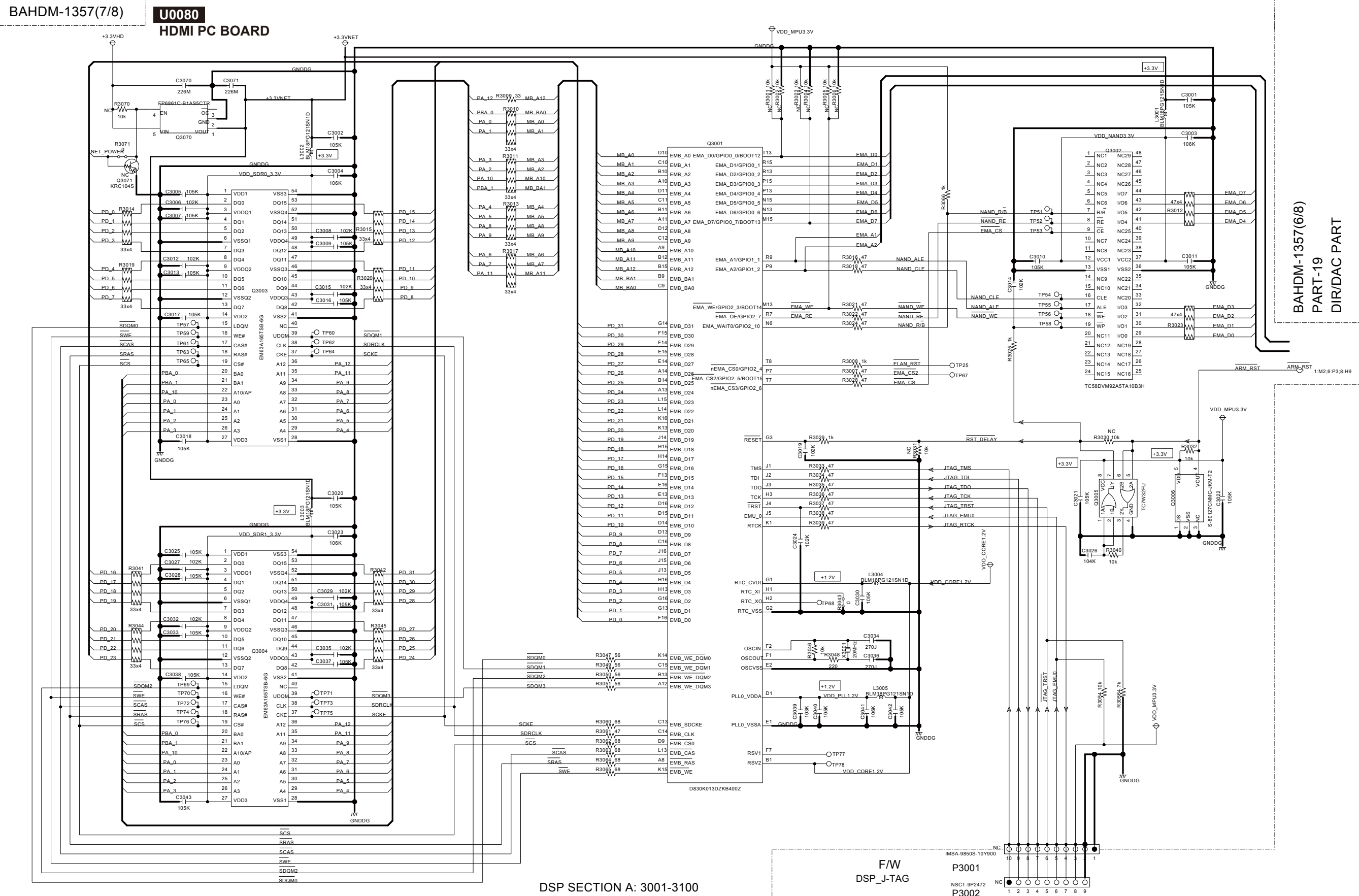

DSP SECTION A: 3001-3100

F/W
DSP_J-TAG

P3001
NSCT-9P2472
P3002

SCHEMATIC DIAGRAMS-21(PART-21)
NET/USB POWER SECTION

1
2
3
4
5
6
7
8

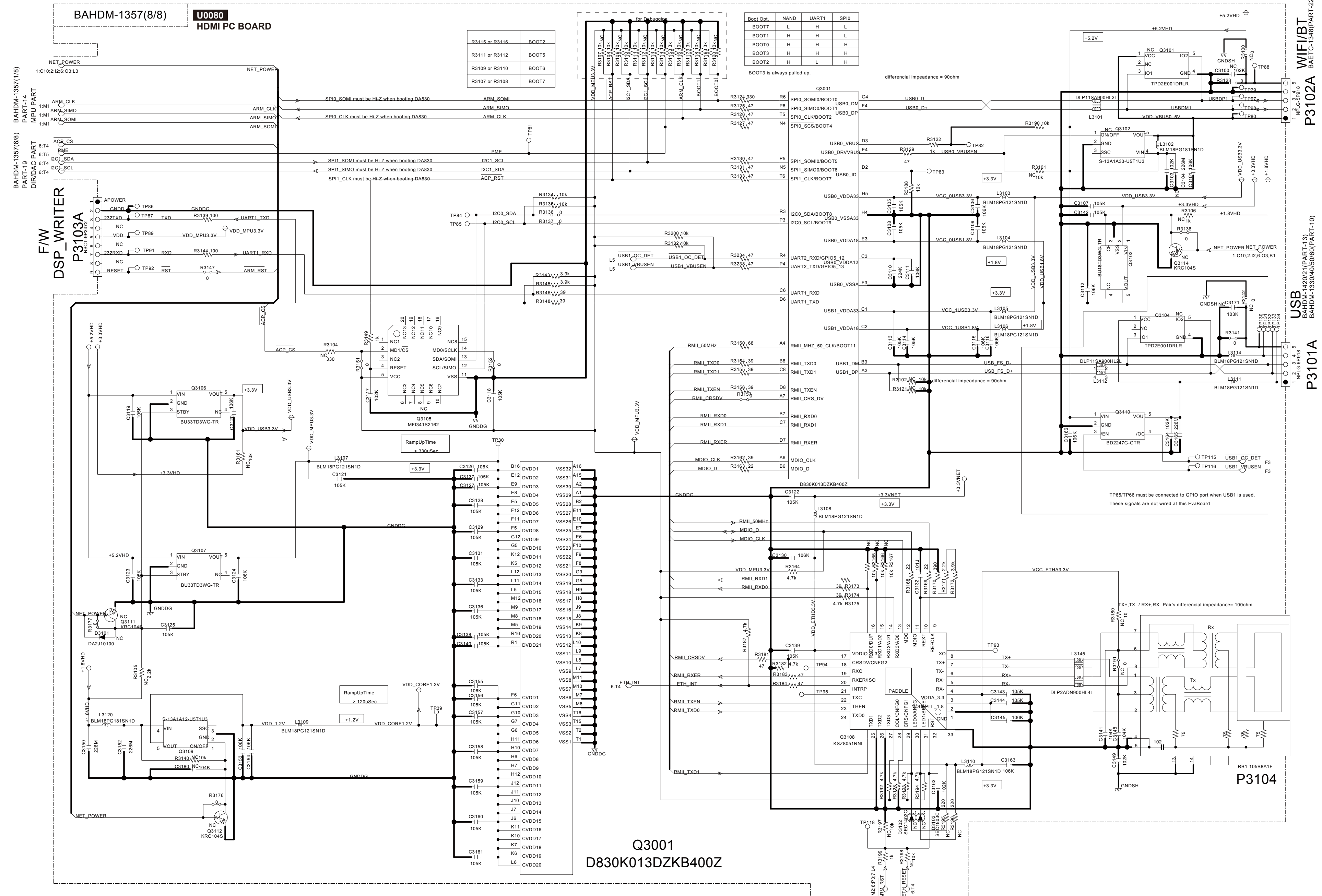

WIFI/BT P3102A BAETC-1348(PART-22)

USB BAHDM-1420/21(PART-13) BAHDM-1330/40/50/60(PART-10)

P3101A

P3104

SCHEMATIC DIAGRAMS-22(PART-22)
Wi-Fi/Bluetooth CONNECTOR SECTION

1

2

3

4

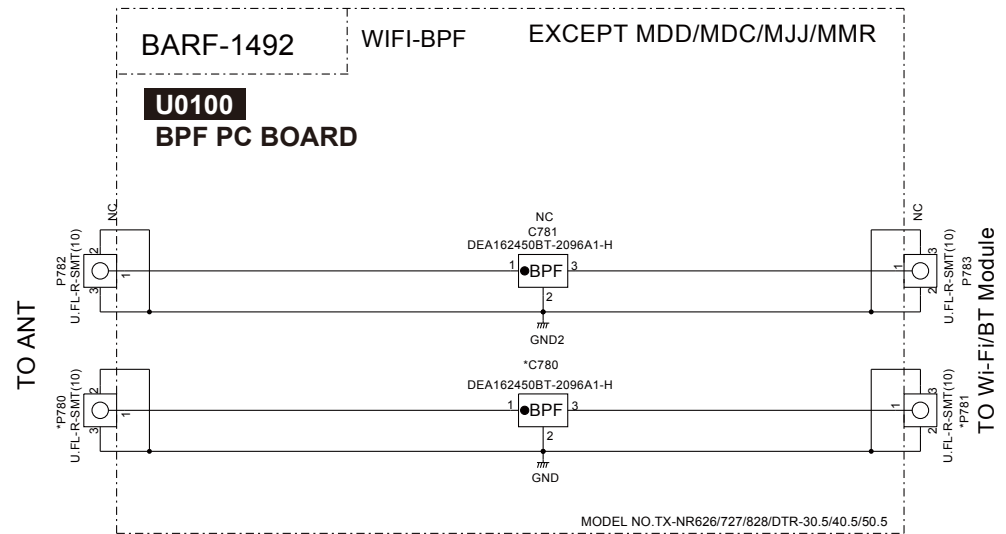
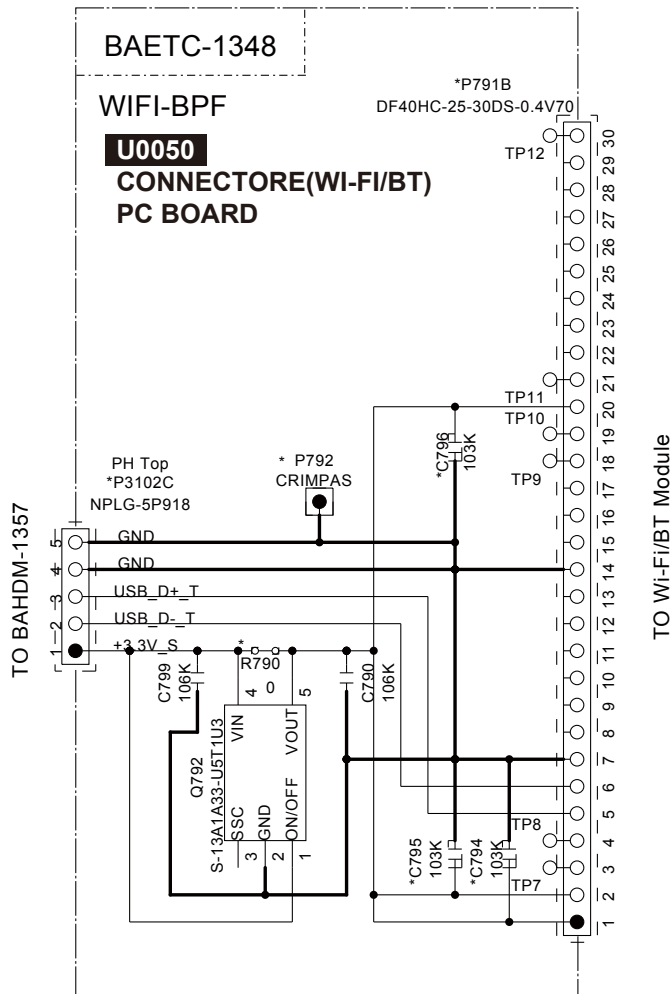

TX-NR727(B)MDC

<Note>

Parts marked by "NSP" are generally unavailable because they are not in our Master Spare Parts List.

NOTE : THE COMPONENTS IDENTIFIED BY THE MARK ! ARE CRITICAL FOR RISK OF FIRE AND ELECTRIC SHOCK. REPLACE ONLY WITH PART NUMBER SPECIFIED.

<Notes>

(B) : Black color model

<MDC> : 120V,Canadian/USA/(Mexico) model

: NSP

TX-NR727(B)MDC

EXPLODED VIEW PARTS LIST

REF. NO.	PART NAME	DESCRIPTION	Q'TY	PART NO. (SN)	REMARKS
[SEMI CONDUCTOR]					
Q6050	TR	2SC5242-O	1	2202843	
Q6050 or	TR	2SC5242-R	(1)	2202842	
Q6051	TR	2SC5242-O	1	2202843	
Q6051 or	TR	2SC5242-R	(1)	2202842	
Q6052	TR	2SC5242-O	1	2202843	
Q6052 or	TR	2SC5242-R	(1)	2202842	
Q6053	TR	2SC5242-O	1	2202843	
Q6053 or	TR	2SC5242-R	(1)	2202842	
Q6054	TR	2SC5242-O	1	2202843	
Q6054 or	TR	2SC5242-R	(1)	2202842	
Q6055	TR	2SC5242-O	1	2202843	
Q6055 or	TR	2SC5242-R	(1)	2202842	
Q6056	TR	2SC5242-O	1	2202843	
Q6056 or	TR	2SC5242-R	(1)	2202842	
Q6060	TR	2SA1962-O	1	2202833	
Q6060 or	TR	2SA1962-R	(1)	2202832	
Q6061	TR	2SA1962-O	1	2202833	
Q6061 or	TR	2SA1962-R	(1)	2202832	
Q6062	TR	2SA1962-O	1	2202833	
Q6062 or	TR	2SA1962-R	(1)	2202832	
Q6063	TR	2SA1962-O	1	2202833	
Q6063 or	TR	2SA1962-R	(1)	2202832	
Q6064	TR	2SA1962-O	1	2202833	
Q6064 or	TR	2SA1962-R	(1)	2202832	
Q6065	TR	2SA1962-O	1	2202833	
Q6065 or	TR	2SA1962-R	(1)	2202832	
Q6066	TR	2SA1962-O	1	2202833	
Q6066 or	TR	2SA1962-R	(1)	2202832	
[CHASSIS SCREW]					
A021	BOTTOM LEG		4	27175452A	
A023	CUSHION	(LEG)	4	28141735	
A077A	LABEL	(E-CON)	{ 1 }	29364978	
A089	REAR PANEL	TXNR727DC	1	27124498A	N
A093	LABEL	(SP)	1	29392278A	
[CABINET]					
A201	F PANEL	TXNR727(B)DC	1	27213648B	N
A203	CLEAR PLT	TXNR727(B)D	1	28192408	N
A205	BADGE		1	28135317	
A207	KNOB	(SEL)	1	28327131	
A209	KNOB	(TONE)(B)	1	28326918	
A211	KNOB	(INP)B	1	28327132	
A213	KNOB	(INP-L)B_727	1	28327138A	N
A215	KNOB	(INP-R)B_727	1	28327140A	N
A217	FACET	(KNOB)	2	28200072A	
A219	KNOB	(STBY)(B)	1	28326904	
A221	KNOB	(CUR)	1	28326996	
A223	FACET	(VOL)	1	28200059A	
A225	SHEET	(WIFI)	1	29096161	N
A701	COVER	(B) (Bent)	1	28210093	
A701	COVER	(B) (Not Bent)	1	28210093Z	
A715	KNOB	(VOL)AS(B)_727	1	28327145B	N
A717	LABEL	(COVER)	1	29364123	
A721	LABEL	HOOKUP-ONKYO	1	29363194	
A729	LABEL	(PT)	1	29363379-1	
[TRANS COIL]					
T901	P TRANS	NPT-1630D	1	2302071	N, !
[SW TRM]					
F6401	FUSE	15A-TUL-250V	1	252303GR	!
F6401 or	FUSE	15A-UL/T-314	(1)	252197GR	!
F6402	FUSE	15A-TUL-250V	1	252303GR	!
F6402 or	FUSE	15A-UL/T-314	(1)	252197GR	!
F9002	FUSE	10A-UL/T-233	1	252330GR	!

F9002 or	FUSE	10A-T/UL-ST2	(1)	252333GR	!
P2510	FAN	KF1225B1E-33ACD54RB	1	24502335	
P2510 or	FAN	4710KL-04W-B10-EA2	(1)	24502332	
P701	FFC	NCFC5-232512	1	2045232512	
P8651	CORD AS	HDMI 0.35M	1	2010499	
P8651 or	CORD AS	HDMI 0.35M	(1)	2010496	
P9001	AC CORD	AS-UC-2	1	253368AYUN	!
P9001 or	AC CORD	AS-UC-2	(1)	253368BLTK	!
[TUNER UNIT]					
U001	U0010, U0011, U0012	BAAF-1320-1A * (Parent)	1	1B288520-1A	MDC
U0010	AUDIO(AMP/ASP) PC BOARD AS	BAAF-1320-1A (Child)	1	1B2885320-1A	
U0011	THERMAL SENSOR PC BOARD AS	BAETC-1321-1A (Child)	1	1B2885321-1A	
U0012	FIX(SENSOR) PC BOARD AS	BAETC-1322-1A (Child)	1	1B2885322-1A	
U002	U0020	BAAMP-1367-1B * (Parent)	1	1B288567-1B	MDC
U0020	TRANSISTOR PC BOARD AS	BAAMP-1367-1B (Child)	1	1B2885367-1B	
U003	U0030, U0031, U0032, U0033, U0034, U0035	BACLA-1328-1A * (Parent)	1	1B288528-1A	MDC
U0030	AMP(CLASS A) PC BOARD AS	BACLA-1328-1A (Child)	1	1B2885328-1A	
U0031	FIX1(FFC1) PC BOARD AS	BAETC-1327-1A (Child)	1	1B2885327-1A	
U0032	FIX1(CLA) PC BOARD AS	BAETC-1329-1A (Child)	1	1B2885329-1A	
U0033	FIX(FFC2) PC BOARD AS	BAETC-1338-1A (Child)	1	1B2885338-1A	
U0035	FIX2(CLA) PC BOARD AS	BAETC-1349-1A (Child)	1	1B2885349-1A	
U0036	FIX2(FRONT USB) PC BOARD AS	BAETC-1354-1A (Child)	1	1B2885354-1A	
U004	U0040, U0041	BATRM-1335-1H * (Parent)	1	1B288535-1H	MDC
U0040	TERMINAL(SPEAKER/VIDEO) PC BOARD AS	BATRM-1335-1H (Child)	1	1B2885335-1H	
U0041	FIX(FRONT HDMI) PC BOARD AS	BAETC-1336-1H (Child)	1	1B2885336-1H	
U005	U0050	BAETC-1348-1B * (Parent)	1	1B288548-1B	MDC
U0050	CONNECTOR(WI-FI/BT) PC BOARD AS	BAETC-1348-1B (Child)	1	1B2885348-1B	
U006	U0060, U0061, U0062, U0063, U0064, U0065	BADIS-1330-1E * (Parent)	1	1B288530-1E	MDC
U0060	DISPLAY PC BOARD AS	BADIS-1330-1E (Child)	1	1B2885330-1E	
U0061	SWITCH(LED PC BOARD AS	BADIS-1331-1E (Child)	1	1B2885331-1E	
U0062	DIGITAL(DAC) PC BOARD AS	BADG-1332-1E (Child)	1	1B2885332-1E	
U0063	POWER SUPPLY(PRI) PC BOARD AS	BAPS-1333-1E (Child)	1	1B2885333-1E	
U0064	PHONE JACK PC BOARD AS	BAETC-1334-1E (Child)	1	1B2885334-1E	
U0065	CONNECTOR PC BOARD AS	BAETC-1316-1E (Child)	1	1B2885316-1E	
U008	U0080, U0081	BAHDM-1357-1B * (Parent)	1	1B288557-1B	MDC
U0080	PROCESSING PC BOARD AS	BAHDM-1357-1B (Child)	1	1B2885357-1B	
U0081	TERMINAL(FRONT HDMI) PC BOARD AS	BAETC-1358-1B (Child)	1	1B2885358-1B	
U011	TUNER UNIT	FAEH08-W01	1	240169A	
U791	WIFI MODULE (U791A+U791B+U791C)	WCBN4601L-O1(wANT_IN)	1	24850701	
U791A	PWB AS	WCBN4601L-O1	1	24150122	
U791B	WIFI BT ANTENA	2.4GHZ ANT L1	1	2050091	
U791C	WIFI BT ANTENA	2.4GHZ ANT R1	1	2050092	

TX-NR727(B)MDC**PACKING PROCEDURES PARTS LIST**

REF. NO.	PART NAME	DESCRIPTION	Q'TY	PART NO. (SN)	REMARKS
[PACKING]					
A801	PAD	(AS)	1	29092663	N
A801A	PAD	(L)	{ 1}	29092664	N
A801B	PAD	(R)	{ 1}	29092665	N
A802	TAPE	(SEROHAN)NITTO NO.29	1	29110149	
A803	CARTON	TXNR727DC	1	29055418	N
A805A	UPC LABEL	TXNR727(B)MDC	{ 1}	29392227	N
A813	SHEET	1300 x 650	1	29096147	
A815	TAPE	(SEROHAN)NITTO NO.29	1	29110149	
A817	POLY BAG	w250xd350	1	29100250A	
A819	TAPE	(SEROHAN)NITTO NO.29	1	29110149	
A821	PP TAPE	W50 SBT-70	1	29110200	
[ACCESSARY]					
A1001	POLY BAG	D250xd300xW300(t0.04)	1	29100256A	
A1003	TAPE	(SEROHAN)NITTO NO.29	1	29110149	
A1005	LABEL	(SPCABLE)2009	1	29390881	
A1007	WRNTY CARD	(ONKYO)	1	29365156	
A1017	REMO CON	RC-868M	1	24140868	
A1019	BATTERY	R6/AA(UM-3)	2	3010194	
A1019 or	BATTERY	R6/AA(UM-3)	(2)	3010054	
A1021	MIC	MIC-7001	1	245045	
A1023	ANT COIL	AM LOOP-ANTENNA	1	232207	
A1025	FM ANT AS	Type W	1	292191	
A1101	INS MANDSK	U7(2013_TX_AVR)	1	29500019D	
A1111	INS MANUAL	QSG_En(TXNR727)	1	29401431	N
A1113	INS MANUAL	QSG_Fr(TXNR727)	1	29401432	N
A1115	INS MANUAL	QSG_Es(TXNR727)	1	29401433	N
A1133	INS MANUAL	SAFETY_U3	1	29400883A	

A1139	INST SHEET	U11(2010_RIHD)	1	29355782G
A1145	SHEET	(FLYER-US)	1	29380162
A1147	INS MANUAL	EnJa(GNU_License_2013)	1	29401470
A1151	INST SHEET	U11(WIFI/BT)	1	29355908

TX-NR727(B)MDC

PC BOARD PARTS LIST

U001

BAAF-1320-1A

: NSP

CIRCUIT NO.	PART NAME	DESCRIPTION	Q'TY	PART NO. (SN)	REMARKS
[SEMI CONDUCTOR]					
D4171	ZENER D	DZ2J075M0L	1	224760750R2	
D4171 or	ZENER D	UDZS7.5B	(1)	224550750R2	
D4172	ZENER D	DZ2J075M0L	1	224760750R2	
D4172 or	ZENER D	UDZS7.5B	(1)	224550750R2	
D4300	DIODE	RL1N4003	1	22380260T	
D4301	DIODE	RL1N4003	1	22380260T	
D4302	DIODE	RL1N4003	1	22380260T	
D4303	DIODE	RL1N4003	1	22380260T	
D4304	DIODE	RL1N4003	1	22380260T	
D4305	DIODE	RL1N4003	1	22380260T	
D4307	C-DIODE	DA2J10100	1	223303R2	
D4307 or	C-DIODE	1SS352	(1)	223234R2	
D4308	C-DIODE	DA2J10100	1	223303R2	
D4308 or	C-DIODE	1SS352	(1)	223234R2	
D4309	C-DIODE	DA2J10100	1	223303R2	
D4309 or	C-DIODE	1SS352	(1)	223234R2	
D4319	C-DIODE	DA2J10100	1	223303R2	
D4319 or	C-DIODE	1SS352	(1)	223234R2	
D4400	ZENER D	DZ2J056M0L	1	224760560R2	
D4400 or	ZENER D	UDZS5.6B	(1)	224550560R2	
D4500	ZENER D	DZ2J075M0L	1	224760750R2	
D4500 or	ZENER D	UDZS7.5B	(1)	224550750R2	
D4501	ZENER D	DZ2J075M0L	1	224760750R2	
D4501 or	ZENER D	UDZS7.5B	(1)	224550750R2	
D6000	C-DIODE	DA2J10100	1	223303R2	
D6000 or	C-DIODE	1SS352	(1)	223234R2	
D6001	C-DIODE	DA2J10100	1	223303R2	
D6001 or	C-DIODE	1SS352	(1)	223234R2	
D6002	C-DIODE	DA2J10100	1	223303R2	
D6002 or	C-DIODE	1SS352	(1)	223234R2	
D6003	C-DIODE	DA2J10100	1	223303R2	
D6003 or	C-DIODE	1SS352	(1)	223234R2	
D6004	C-DIODE	DA2J10100	1	223303R2	
D6004 or	C-DIODE	1SS352	(1)	223234R2	
D6005	C-DIODE	DA2J10100	1	223303R2	
D6005 or	C-DIODE	1SS352	(1)	223234R2	
D6006	C-DIODE	DA2J10100	1	223303R2	
D6006 or	C-DIODE	1SS352	(1)	223234R2	
D6401	DIODE	TS10B06G-07	1	22380379	
D6401B	SCREW	3P+10FN(3BC)	1	82143010GR	
D6402	C-DIODE	DA2J10100	1	223303R2	
D6402 or	C-DIODE	1SS352	(1)	223234R2	
D6451	C-DIODE	DA2J10100	1	223303R2	
D6451 or	C-DIODE	1SS352	(1)	223234R2	
D6452	C-DIODE	DA2J10100	1	223303R2	
D6452 or	C-DIODE	1SS352	(1)	223234R2	
D6455	ZENER D	DZ2J033M0L	1	224760330R2	
D6455 or	ZENER D	UDZS3.3B	(1)	224550330R2	
Q4001	IC	R2A15220FP	1	22242600R3	
Q4003	IC	NJM4580M-D	1	22241448R2	
Q4100	TR	RN1441	1	2215410R2	
Q4100 or	TR	RTAN430C-T112-1	(1)	2217780R2	
Q4101	TR	RN1441	1	2215410R2	
Q4101 or	TR	RTAN430C-T112-1	(1)	2217780R2	
Q4102	TR	RN1441	1	2215410R2	
Q4102 or	TR	RTAN430C-T112-1	(1)	2217780R2	
Q4103	TR	RN1441	1	2215410R2	
Q4103 or	TR	RTAN430C-T112-1	(1)	2217780R2	
Q4104	TR	RN1441	1	2215410R2	
Q4104 or	TR	RTAN430C-T112-1	(1)	2217780R2	
Q4105	TR	RN1441	1	2215410R2	
Q4105 or	TR	RTAN430C-T112-1	(1)	2217780R2	
Q4106	TR	RN1441	1	2215410R2	

Q4106 or	TR	RTAN430C-T112-1	(1)	2217780R2
Q4107	TR	RN1441	1	2215410R2
Q4107 or	TR	RTAN430C-T112-1	(1)	2217780R2
Q4117	TR	RN1441	1	2215410R2
Q4117 or	TR	RTAN430C-T112-1	(1)	2217780R2
Q4130	IC	NJM4580M-D	1	22241448R2
Q4170	IC	78M15HF(NJM78M15FA)	1	222780155JRC
Q4170 or	IC	UPC78M15AHF-AZ	(1)	222780155NEC
Q4170A	HEAT SINK	RAD-196	1	27160545
Q4170B	SCREW	3P+10FN(3BC)	1	82143010GR
Q4171	IC	79M15HF(NJM79M15FA)	1	222790155JRC
Q4171 or	IC	UPC79M15HF-AZ	(1)	222790155NEC
Q4171B	SCREW	3P+10FN(3BC)	1	82143010GR
Q4184	TR	2SC2881-Y(TE12L,CF)	1	2217564R2
Q4185	TR	2SA1201-Y(TE12L,CF)	1	2217554R2
Q4302	TR	RN1441	1	2215410R2
Q4302 or	TR	RTAN430C-T112-1	(1)	2217780R2
Q4303	TR	RN1441	1	2215410R2
Q4303 or	TR	RTAN430C-T112-1	(1)	2217780R2
Q4304	TR	RN1441	1	2215410R2
Q4304 or	TR	RTAN430C-T112-1	(1)	2217780R2
Q4305	TR	RN1441	1	2215410R2
Q4305 or	TR	RTAN430C-T112-1	(1)	2217780R2
Q4400	TR	2SC2881-Y(TE12L,CF)	1	2217564R2
Q4501	IC	NJM4580M-D	1	22241448R2
Q4502	IC	NJM4580M-D	1	22241448R2
Q4503	IC	NJM4580M-D	1	22241448R2
Q4530	IC	NJM4580M-D	1	22241448R2
Q6000	TR	2SC2412K-R	1	2214653R2
Q6000 or	TR	KTC3875-GR	(1)	2216175R2
Q6001	TR	2SC2412K-R	1	2214653R2
Q6001 or	TR	KTC3875-GR	(1)	2216175R2
Q6002	TR	2SC2412K-R	1	2214653R2
Q6002 or	TR	KTC3875-GR	(1)	2216175R2
Q6003	TR	2SC2412K-R	1	2214653R2
Q6003 or	TR	KTC3875-GR	(1)	2216175R2
Q6004	TR	2SC2412K-R	1	2214653R2
Q6004 or	TR	KTC3875-GR	(1)	2216175R2
Q6005	TR	2SC2412K-R	1	2214653R2
Q6005 or	TR	KTC3875-GR	(1)	2216175R2
Q6006	TR	2SC2412K-R	1	2214653R2
Q6006 or	TR	KTC3875-GR	(1)	2216175R2
Q6070	TR	INC6006AP1-T111	1	2217990R2
Q6070 or	TR	2SC2880-Y(2LONK_ZE)	(1)	2217594R2
Q6071	TR	INC6006AP1-T111	1	2217990R2
Q6071 or	TR	2SC2880-Y(2LONK_ZE)	(1)	2217594R2
Q6072	TR	INC6006AP1-T111	1	2217990R2
Q6072 or	TR	2SC2880-Y(2LONK_ZE)	(1)	2217594R2
Q6073	TR	INC6006AP1-T111	1	2217990R2
Q6073 or	TR	2SC2880-Y(2LONK_ZE)	(1)	2217594R2
Q6074	TR	INC6006AP1-T111	1	2217990R2
Q6074 or	TR	2SC2880-Y(2LONK_ZE)	(1)	2217594R2
Q6075	TR	INC6006AP1-T111	1	2217990R2
Q6075 or	TR	2SC2880-Y(2LONK_ZE)	(1)	2217594R2
Q6076	TR	INC6006AP1-T111	1	2217990R2
Q6076 or	TR	2SC2880-Y(2LONK_ZE)	(1)	2217594R2
Q6300	IC	LM61CIZ	1	22242212
Q6300A	RETAINER	(PTH)	1	27141884-1
Q6401	TR	2SC2712-GR	1	2213145R2
Q6401 or	TR	KTC3875-GR	(1)	2216175R2
Q6401A	HEAT SINK	RAD-165	1	27160500
Q6451	TR	2SC2713-BL	1	2213136R2
Q6452	TR	2SC2713-BL	1	2213136R2
Q6453	TR	2SA1163-BL(TE85L_F)	1	2216756R2
Q6454	TR	2SA1163-BL(TE85L_F)	1	2216756R2
[TRANS COIL]				
L6000	S-COIL	SC-0.8X5.5X18.5T	1	231431S
L6000 or	S-COIL	PI-ROD002-0083	(1)	231454S
L6000 or	S-COIL	SC2-0.8X5.5X18.5T	(1)	231455S
L6000 or	S COIL	E6-S/33331	(1)	231460S
L6001	S-COIL	SC-0.8X5.5X18.5T	1	231431S
L6001 or	S-COIL	PI-ROD002-0083	(1)	231454S
L6001 or	S-COIL	SC2-0.8X5.5X18.5T	(1)	231455S
L6001 or	S COIL	E6-S/33331	(1)	231460S
L6002	S-COIL	SC-0.8X5.5X18.5T	1	231431S
L6002 or	S-COIL	PI-ROD002-0083	(1)	231454S

L6002 or	S-COIL	SC2-0.8X5.5X18.5T	(1)	231455S
L6002 or	S COIL	E6-S/33331	(1)	231460S
L6003	S-COIL	SC-0.8X5.5X18.5T	1	231431S
L6003 or	S-COIL	PI-ROD002-0083	(1)	231454S
L6003 or	S-COIL	SC2-0.8X5.5X18.5T	(1)	231455S
L6003 or	S COIL	E6-S/33331	(1)	231460S
L6004	S-COIL	SC-0.8X5.5X18.5T	1	231431S
L6004 or	S-COIL	PI-ROD002-0083	(1)	231454S
L6004 or	S-COIL	SC2-0.8X5.5X18.5T	(1)	231455S
L6004 or	S COIL	E6-S/33331	(1)	231460S
L6005	S-COIL	SC-0.8X5.5X18.5T	1	231431S
L6005 or	S-COIL	PI-ROD002-0083	(1)	231454S
L6005 or	S-COIL	SC2-0.8X5.5X18.5T	(1)	231455S
L6005 or	S COIL	E6-S/33331	(1)	231460S
L6006	S-COIL	SC-0.8X5.5X18.5T	1	231431S
L6006 or	S-COIL	PI-ROD002-0083	(1)	231454S
L6006 or	S-COIL	SC2-0.8X5.5X18.5T	(1)	231455S
L6006 or	S COIL	E6-S/33331	(1)	231460S
[CAPACITOR]				
C4001	C-CERA C	CC725CH1H-102J1	1	342101024R1
C4002	C-CERA C	CC725CH1H-102J1	1	342101024R1
C4003	C-CERA C	CC725CH1H-221J1	1	342102214R1
C4004	C-CERA C	CC725CH1H-221J1	1	342102214R1
C4007	UPZ C	2AUPZTF221JE	1	376332214T
C4008	UPZ C	2AUPZTF221JE	1	376332214T
C4009	C-CERA C	CC725CH1H-221J1	1	342102214R1
C4010	C-CERA C	CC725CH1H-221J1	1	342102214R1
C4013	C-CERA C	CC725CH1H-221J1	1	342102214R1
C4014	C-CERA C	CC725CH1H-221J1	1	342102214R1
C4017	C-CERA C	CC725CH1H-221J1	1	342102214R1
C4018	C-CERA C	CC725CH1H-221J1	1	342102214R1
C4019	UPZ C	2AUPZTF221JE	1	376332214T
C4020	UPZ C	2AUPZTF221JE	1	376332214T
C4021	C-CERA C	CC725CH1H-220J1	1	342102204R1
C4022	C-CERA C	CC725CH1H-220J1	1	342102204R1
C4037	C-CERA C	CC725CH1H-221J1	1	342102214R1
C4050	UTSP C	CE04W10V-220M(UTSP)	1	397532217AT
C4051	UTSP C	CE04W10V-220M(UTSP)	1	397532217AT
C4052	UTSP C	CE04W10V-220M(UTSP)	1	397532217AT
C4053	UTSP C	CE04W25V-47M(UTSP)	1	397554707AT
C4054	UTSP C	CE04W25V-47M(UTSP)	1	397554707AT
C4055	UTSP C	CE04W25V-47M(UTSP)	1	397554707AT
C4056	UTSP C	CE04W25V-47M(UTSP)	1	397554707AT
C4057	UTSP C	CE04W25V-47M(UTSP)	1	397554707AT
C4060	UTSP C	CE04W50V 47M(UTSP)	1	397584707AT
C4061	UTSP C	CE04W50V 47M(UTSP)	1	397584707AT
C4070	UTSP C	CE04W50V 47M(UTSP)	1	397584707AT
C4071	UTSP C	CE04W50V 47M(UTSP)	1	397584707AT
C4072	UTSP C	CE04W50V 47M(UTSP)	1	397584707AT
C4073	UTSP C	CE04W50V 47M(UTSP)	1	397584707AT
C4074	UTSP C	CE04W50V 47M(UTSP)	1	397584707AT
C4075	UTSP C	CE04W50V 47M(UTSP)	1	397584707AT
C4076	UTSP C	CE04W50V 47M(UTSP)	1	397584707AT
C4077	UTSP C	CE04W50V 47M(UTSP)	1	397584707AT
C4078	UTSP C	CE04W50V 47M(UTSP)	1	397584707AT
C4079	UTSP C	CE04W50V 47M(UTSP)	1	397584707AT
C4090	C-CERA C	CC725CH1H-101J1	1	342101014R1
C4091	C-CERA C	CC725CH1H-101J1	1	342101014R1
C4100	UTSP C	CE04W50V 47M(UTSP)	1	397584707AT
C4101	UTSP C	CE04W50V 47M(UTSP)	1	397584707AT
C4102	UTSP C	CE04W50V 47M(UTSP)	1	397584707AT
C4103	UTSP C	CE04W50V 47M(UTSP)	1	397584707AT
C4104	UTSP C	CE04W50V 47M(UTSP)	1	397584707AT
C4105	UTSP C	CE04W50V 47M(UTSP)	1	397584707AT
C4106	UTSP C	CE04W50V 47M(UTSP)	1	397584707AT
C4107	UTSP C	CE04W50V 47M(UTSP)	1	397584707AT
C4108	UTSP C	CE04W50V 47M(UTSP)	1	397584707AT
C4109	UTSP C	CE04W50V 47M(UTSP)	1	397584707AT
C4110	UTSP C	CE04W25V-47M(UTSP)	1	397554707AT
C4111	UTSP C	CE04W25V-47M(UTSP)	1	397554707AT
C4130	UTSP C	CE04W50V 47M(UTSP)	1	397584707AT
C4131	C-CERA C	CC725CH1H-221J1	1	342102214R1
C4132	TF C	EQQ-V50V-103J	1	374721034T
C4166	UTSP C	CE04W25V-220M(UTSP)	1	397552217T
C4167	UTSP C	CE04W25V-220M(UTSP)	1	397552217T
C4170	UTSP C	CE04W50V-10M(UTSP)	1	397581007AT

C4171	UTSP C	CE04W50V-10M(UTSP)	1	397581007AT
C4172	UTSP C	CE04W25V-220M(UTSP)	1	397552217T
C4173	UTSP C	CE04W25V-220M(UTSP)	1	397552217T
C4174	UTSP C	CE04W16V-470M(UTSP)	1	397544717T
C4175	UTSP C	CE04W16V-470M(UTSP)	1	397544717T
C4184	UTSP C	CE04W25V-220M(UTSP)	1	397552217T
C4185	UTSP C	CE04W25V-220M(UTSP)	1	397552217T
C4186	UTSP C	CE04W25V-220M(UTSP)	1	397552217T
C4187	UTSP C	CE04W25V-220M(UTSP)	1	397552217T
C4201	C-CERA C	CC725CH1H-102J1	1	342101024R1
C4203	C-CERA C	CC725CH1H-102J1	1	342101024R1
C4204	C-CERA C	CC725CH1H-102J1	1	342101024R1
C4206	C-CERA C	CC725CH1H-102J1	1	342101024R1
C4209	UTSP C	CE04W25V-47M(UTSP)	1	397554707AT
C4210	UTSP C	CE04W25V-47M(UTSP)	1	397554707AT
C4212	TF C	ECQ-V50V-104J	1	374721044T
C4300	TF C	ECQ-V50V-334J	1	374723344T
C4301	JAMICON	CE04W35V-1000M	1	398561027T
C4301 or	VR C	CE04W35V-1000M(VR)	(1)	394661027T
C4302	JAMICON	CE04W35V-470M	1	398564717T
C4302 or	VR C	CE04W35V-470M(VR)	(1)	394664717T
C4305	C-CERA C	CC725CH1H-221J1	1	342102214R1
C4306	C-CERA C	CC725CH1H-221J1	1	342102214R1
C4322	C-CERA C	CC725CH1H-221J1	1	342102214R1
C4323	C-CERA C	CC725CH1H-221J1	1	342102214R1
C4324	C-CERA C	CC725CH1H-102J1	1	342101024R1
C4331	UTSP C	CE04W50V 47M(UTSP)	1	397584707AT
C4332	UTSP C	CE04W50V 47M(UTSP)	1	397584707AT
C4400	C-CERA C	CK725B1H-102K1	1	332101025R1
C4401	C-CERA C	CK725B1H-102K1	1	332101025R1
C4404	UTSP C	CE04W25V-47M(UTSP)	1	397554707AT
C4501	UTSP C	CE04W50V 47M(UTSP)	1	397584707AT
C4502	UTSP C	CE04W50V 47M(UTSP)	1	397584707AT
C4505	UTSP C	CE04W50V 47M(UTSP)	1	397584707AT
C4506	TF C	ECQ-V50V-105J	1	374721054T
C4507	C-CERA C	CK725F1H-224Z1	1	332152240R1
C4508	UTSP C	CE04W50V 47M(UTSP)	1	397584707AT
C4509	UTSP C	CE04W25V-47M(UTSP)	1	397554707AT
C4510	UTSP C	CE04W25V-47M(UTSP)	1	397554707AT
C4530	UTSP C	CE04W25V-47M(UTSP)	1	397554707AT
C4531	UTSP C	CE04W25V-47M(UTSP)	1	397554707AT
C4532	C-CERA C	CC725CH1H-152J1	1	342101524R1
C4533	C-CERA C	CC725CH1H-152J1	1	342101524R1
C4534	TF C	ECQ-V50V-123J	1	374721234T
C4535	TF C	ECQ-V50V-123J	1	374721234T
C4536	MKT C	B32529C0332J289	1	376493324T
C4537	MKT C	B32529C0332J289	1	376493324T
C4538	C-CERA C	CC725CH1H-151J1	1	342101514R1
C4539	C-CERA C	CC725CH1H-151J1	1	342101514R1
C4540	C-CERA C	CC725CH1H-471J1	1	342104714R1
C4541	C-CERA C	CC725CH1H-471J1	1	342104714R1
C4542	C-CERA C	CC725CH1H-101J1	1	342101014R1
C4543	C-CERA C	CC725CH1H-101J1	1	342101014R1
C4544	UTSP C	CE04W50V-10M(UTSP)	1	397581007AT
C4545	UTSP C	CE04W50V-10M(UTSP)	1	397581007AT
C4546	UTSP C	CE04W25V-47M(UTSP)	1	397554707AT
C4547	UTSP C	CE04W25V-47M(UTSP)	1	397554707AT
C4548	C-CERA C	CK725F1E-104Z1	1	332161040R1
C4549	C-CERA C	CK725F1E-104Z1	1	332161040R1
C4550	UTSP C	CE04W10V-220M(UTSP)	1	397532217AT
C4551	UTSP C	CE04W10V-220M(UTSP)	1	397532217AT
C6050	TF C	ECQ-V50V-103J	1	374721034T
C6051	TF C	ECQ-V50V-103J	1	374721034T
C6052	TF C	ECQ-V50V-103J	1	374721034T
C6053	TF C	ECQ-V50V-103J	1	374721034T
C6054	TF C	ECQ-V50V-103J	1	374721034T
C6055	TF C	ECQ-V50V-103J	1	374721034T
C6056	TF C	ECQ-V50V-103J	1	374721034T
C6250	TF C	ECQ-V50V-473J	1	374724734T
C6251	TF C	ECQ-V50V-473J	1	374724734T
C6252	TF C	ECQ-V50V-473J	1	374724734T
C6253	TF C	ECQ-V50V-473J	1	374724734T
C6254	TF C	ECQ-V50V-473J	1	374724734T
C6255	TF C	ECQ-V50V-473J	1	374724734T
C6256	TF C	ECQ-V50V-473J	1	374724734T
C6300	C-CERA C	CK725F1E-104Z1	1	332161040R1

C6301	C-CERA C	CK725F1E-104Z1	1	332161040R1	
C6401	ELECT C	CE69W71V-12000M	1	3504504	N
C6402	ELECT C	CE69W71V-12000M	1	3504504	N
C6403	TF C	EQQ-V100V-334J	1	374733344T	
C6404	TF C	EQQ-V100V-334J	1	374733344T	
C6408	C-CERA C	CC725CH1H-102J1	1	342101024R1	
C6451	UTSP C	CE04W10V-220M(UTSP)	1	397532217AT	
C6452	C-CERA C	CK725F1H-104Z1	1	332151040R1	
C6453	UTSP C	CE04W50V-1M(UTSP)	1	397580107AT	
C6454	UTSP C	CE04W50V-1M(UTSP)	1	397580107AT	
C6455	C-CERA C	CK725F1H-104Z1	1	332151040R1	
C6456	UTSP C	CE04W50V-10M(UTSP)	1	397581007AT	
[RESISTOR]					
R4001	C-CARBON R	RN72K1J-331JE	1	435033314R1	
R4002	C-CARBON R	RN72K1J-331JE	1	435033314R1	
R4003	C-CARBON R	RN72K1J-331JE	1	435033314R1	
R4004	C-CARBON R	RN72K1J-331JE	1	435033314R1	
R4007	C-CARBON R	RN72K1J-331JE	1	435033314R1	
R4008	C-CARBON R	RN72K1J-331JE	1	435033314R1	
R4009	C-CARBON R	RN72K1J-331JE	1	435033314R1	
R4010	C-CARBON R	RN72K1J-331JE	1	435033314R1	
R4013	C-CARBON R	RN72K1J-331JE	1	435033314R1	
R4014	C-CARBON R	RN72K1J-331JE	1	435033314R1	
R4017	C-CARBON R	RN72K1J-331JE	1	435033314R1	
R4018	C-CARBON R	RN72K1J-331JE	1	435033314R1	
R4019	C-CARBON R	RN72K1J-331JE	1	435033314R1	
R4020	C-CARBON R	RN72K1J-331JE	1	435033314R1	
R4027	C-CARBON R	RN72K1J-223JE	1	435032234R1	
R4029	C-CARBON R	RN72K1J-101JE	1	435031014R1	
R4038	C-CARBON R	RN72K1J-101JE	1	435031014R1	
R4041	C-CARBON R	RN72K1J-563JE	1	435035634R1	
R4042	C-CARBON R	RN72K1J-563JE	1	435035634R1	
R4043	C-CARBON R	RN72K1J-104JE	1	435031044R1	
R4044	C-CARBON R	RN72K1J-104JE	1	435031044R1	
R4047	C-CARBON R	RN72K1J-104JE	1	435031044R1	
R4048	C-CARBON R	RN72K1J-104JE	1	435031044R1	
R4049	C-CARBON R	RN72K1J-104JE	1	435031044R1	
R4050	C-CARBON R	RN72K1J-104JE	1	435031044R1	
R4053	C-CARBON R	RN72K1J-104JE	1	435031044R1	
R4054	C-CARBON R	RN72K1J-104JE	1	435031044R1	
R4057	C-CARBON R	RN72K1J-104JE	1	435031044R1	
R4058	C-CARBON R	RN72K1J-104JE	1	435031044R1	
R4059	C-CARBON R	RN72K1J-104JE	1	435031044R1	
R4060	C-CARBON R	RN72K1J-104JE	1	435031044R1	
R4069	C-CARBON R	RN72K1J-104JE	1	435031044R1	
R4082	C-CARBON R	RN72K1J-104JE	1	435031044R1	
R4083	C-CARBON R	RN72K1J-104JE	1	435031044R1	
R4084	C-CARBON R	RN72K1J-104JE	1	435031044R1	
R4087	C-CARBON R	RN72K1J-222JE	1	435032224R1	
R4088	C-CARBON R	RN72K1J-222JE	1	435032224R1	
R4090	C-CARBON R	RN72K1J-123JE	1	435031234R1	
R4091	C-CARBON R	RN72K1J-223JE	1	435032234R1	
R4092	C-CARBON R	RN72K1J-331JE	1	435033314R1	
R4093	C-CARBON R	RN72K1J-332JE	1	435033324R1	
R4094	C-CARBON R	RN72K1J-103JE	1	435031034R1	
R4095	C-CARBON R	RN72K1J-103JE	1	435031034R1	
R4096	C-CARBON R	RN72K1J-331JE	1	435033314R1	
R4097	C-CARBON R	RN72K1J-332JE	1	435033324R1	
R4098	C-CARBON R	RN72K1J-123JE	1	435031234R1	
R4099	C-CARBON R	RN72K1J-223JE	1	435032234R1	
R4100	C-CARBON R	RN72K1J-224JE	1	435032244R1	
R4101	C-CARBON R	RN72K1J-224JE	1	435032244R1	
R4102	C-CARBON R	RN72K1J-224JE	1	435032244R1	
R4103	C-CARBON R	RN72K1J-224JE	1	435032244R1	
R4104	C-CARBON R	RN72K1J-224JE	1	435032244R1	
R4105	C-CARBON R	RN72K1J-224JE	1	435032244R1	
R4106	C-CARBON R	RN72K1J-224JE	1	435032244R1	
R4107	C-CARBON R	RN72K1J-224JE	1	435032244R1	
R4108	C-CARBON R	RN72K1J-224JE	1	435032244R1	
R4109	C-CARBON R	RN72K1J-224JE	1	435032244R1	
R4110	C-CARBON R	RN72K1J-222JE	1	435032224R1	
R4111	C-CARBON R	RN72K1J-222JE	1	435032224R1	
R4112	C-CARBON R	RN72K1J-222JE	1	435032224R1	
R4113	C-CARBON R	RN72K1J-222JE	1	435032224R1	
R4114	C-CARBON R	RN72K1J-222JE	1	435032224R1	
R4115	C-CARBON R	RN72K1J-222JE	1	435032224R1	

R4116	C-CARBON R	RN72K1J-222JE	1	435032224R1
R4117	C-CARBON R	RN72K1J-271JE	1	435032714R1
R4120	C-CARBON R	RN72K1J-000JE	1	435030004R1
R4121	C-CARBON R	RN72K1J-000JE	1	435030004R1
R4122	C-CARBON R	RN72K1J-000JE	1	435030004R1
R4123	C-CARBON R	RN72K1J-000JE	1	435030004R1
R4124	C-CARBON R	RN72K1J-000JE	1	435030004R1
R4125	C-CARBON R	RN72K1J-000JE	1	435030004R1
R4126	C-CARBON R	RN72K1J-000JE	1	435030004R1
R4127	C-CARBON R	RN72K1J-101JE	1	435031014R1
R4130	C-CARBON R	RN72K1J-221JE	1	435032214R1
R4131	C-CARBON R	RN72K1J-473JE	1	435034734R1
R4132	C-CARBON R	RN72K1J-153JE	1	435031534R1
R4133	C-CARBON R	RN72K1J-122JE	1	435031224R1
R4134	C-CARBON R	RN72K1J-103JE	1	435031034R1
R4160	METAL R	RNU1WCJ-3.3	1	453630334T
R4161	METAL R	RNU1WCJ-3.3	1	453630334T
R4162	METAL R	RNU1WCJ-3.3	1	453630334T
R4163	METAL R	RNU1WCJ-3.3	1	453630334T
R4166	C-CARBON R	RN72K1J-220JE	1	435032204R1
R4167	C-CARBON R	RN72K1J-220JE	1	435032204R1
R4170	METAL R	RNU1WCJ-4.7	1	453630474T
R4171	METAL R	RNU1WCJ-6.8	1	453630684T
R4174	METAL O R	RS1WBJ-15	1	443621504T
R4175	METAL O R	RS1WBJ-15	1	443621504T
R4176	METAL O R	RS1WBJ-15	1	443621504T
R4177	METAL O R	RS1WBJ-15	1	443621504T
R4180	C-CARBON R	RN72K1J-224JE	1	435032244R1
R4181	C-CARBON R	RN72K1J-224JE	1	435032244R1
R4182	C-CARBON R	RN72K1J-224JE	1	435032244R1
R4183	C-CARBON R	RN72K1J-471JE	1	435034714R1
R4184	C-CARBON R	RN72K1J-471JE	1	435034714R1
R4185	C-CARBON R	RN72K1J-224JE	1	435032244R1
R4186	C-CARBON R	RN72K1J-471JE	1	435034714R1
R4187	C-CARBON R	RN72K1J-471JE	1	435034714R1
R4189	C-CARBON R	RN72K1J-224JE	1	435032244R1
R4190	C-CARBON R	RN72K1J-224JE	1	435032244R1
R4192	C-CARBON R	RN72K1J-224JE	1	435032244R1
R4193	C-CARBON R	RN72K1J-224JE	1	435032244R1
R4194	C-CARBON R	RN72K1J-224JE	1	435032244R1
R4195	C-CARBON R	RN72K1J-224JE	1	435032244R1
R4196	C-CARBON R	RN72K1J-224JE	1	435032244R1
R4197	METAL O R	RS1WBJ-15	1	443621504T
R4198	METAL O R	RS1WBJ-15	1	443621504T
R4199	C-CARBON R	RN72K1J-102JE	1	435031024R1
R4304	C-CARBON R	RN72K1J-101JE	1	435031014R1
R4305	C-CARBON R	RN72K1J-101JE	1	435031014R1
R4306	C-CARBON R	RN72K1J-222JE	1	435032224R1
R4307	C-CARBON R	RN72K1J-222JE	1	435032224R1
R4308	C-CARBON R	RN72K1J-222JE	1	435032224R1
R4309	C-CARBON R	RN72K1J-222JE	1	435032224R1
R4312	C-CARBON R	RN72K1J-224JE	1	435032244R1
R4313	C-CARBON R	RN72K1J-224JE	1	435032244R1
R4322	C-CARBON R	RN72K1J-222JE	1	435032224R1
R4323	C-CARBON R	RN72K1J-222JE	1	435032224R1
R4324	C-CARBON R	RN72K1J-101JE	1	435031014R1
R4325	C-CARBON R	RN72K1J-101JE	1	435031014R1
R4329	C-CARBON R	RN72K1J-222JE	1	435032224R1
R4330	C-CARBON R	RN72K1J-222JE	1	435032224R1
R4400	C-CARBON R	RN72K1J-102JE	1	435031024R1
R4401	C-CARBON R	RN72K1J-102JE	1	435031024R1
R4402	C-CARBON R	RN72K1J-104JE	1	435031044R1
R4403	C-CARBON R	RN72K1J-104JE	1	435031044R1
R4404	C-CARBON R	RN72K1J-681JE	1	435036814R1
R4405	METAL O R	RS1WBJ-100	1	443621014T
R4406	C-CARBON R	RN72K1J-681JE	1	435036814R1
R4407	C-CARBON R	RN72K1J-333JE	1	435033334R1
R4501	C-CARBON R	RN72K1J-224JE	1	435032244R1
R4502	C-CARBON R	RN72K1J-224JE	1	435032244R1
R4503	C-CARBON R	RN72K1J-562JE	1	435035624R1
R4504	C-CARBON R	RN72K1J-683JE	1	435036834R1
R4505	C-CARBON R	RN72K1J-103JE	1	435031034R1
R4506	C-CARBON R	RN72K1J-103JE	1	435031034R1
R4507	C-CARBON R	RN72K1J-103JE	1	435031034R1
R4508	C-CARBON R	RN72K1J-103JE	1	435031034R1
R4510	C-CARBON R	RN72K1J-224JE	1	435032244R1

R4511	C-CARBON R	RN72K1J-682JE	1	435036824R1
R4512	C-CARBON R	RN72K1J-272JE	1	435032724R1
R4513	C-CARBON R	RN72K1J-682JE	1	435036824R1
R4514	C-CARBON R	RN72K1J-224JE	1	435032244R1
R4515	C-CARBON R	RN72K1J-220JE	1	435032204R1
R4516	C-CARBON R	RN72K1J-220JE	1	435032204R1
R4530	C-CARBON R	RN72K1J-104JE	1	435031044R1
R4531	C-CARBON R	RN72K1J-104JE	1	435031044R1
R4532	C-CARBON R	RN72K1J-561JE	1	435035614R1
R4533	C-CARBON R	RN72K1J-561JE	1	435035614R1
R4534	C-CARBON R	RN72K1J-274JE	1	435032744R1
R4535	C-CARBON R	RN72K1J-274JE	1	435032744R1
R4536	C-CARBON R	RN72K1J-223JE	1	435032234R1
R4537	C-CARBON R	RN72K1J-223JE	1	435032234R1
R4538	C-CARBON R	RN72K1J-122JE	1	435031224R1
R4539	C-CARBON R	RN72K1J-122JE	1	435031224R1
R4540	C-CARBON R	RN72K1J-101JE	1	435031014R1
R4541	C-CARBON R	RN72K1J-101JE	1	435031014R1
R4542	C-CARBON R	RN72K1J-104JE	1	435031044R1
R4543	C-CARBON R	RN72K1J-104JE	1	435031044R1
R4544	C-CARBON R	RN72K1J-220JE	1	435032204R1
R4545	C-CARBON R	RN72K1J-220JE	1	435032204R1
R4546	C-CARBON R	RN72K1J-224JE	1	435032244R1
R4547	C-CARBON R	RN72K1J-224JE	1	435032244R1
R4548	C-CARBON R	RN72K1J-271JE	1	435032714R1
R4549	C-CARBON R	RN72K1J-271JE	1	435032714R1
R4550	C-CARBON R	RN72K1J-271JE	1	435032714R1
R4551	C-CARBON R	RN72K1J-271JE	1	435032714R1
R4602	C-CARBON R	RN72K1J-000JE	1	435030004R1
R4603	C-CARBON R	RN72K1J-000JE	1	435030004R1
R4605	C-CARBON R	RN72K1J-000JE	1	435030004R1
R4606	C-CARBON R	RN72K1J-000JE	1	435030004R1
R4607	C-CARBON R	RN72K1J-000JE	1	435030004R1
R4608	C-CARBON R	RN72K1J-000JE	1	435030004R1
R4610	C-CARBON R	RN72K1J-000JE	1	435030004R1
R4611	C-CARBON R	RN72K1J-000JE	1	435030004R1
R4612	C-CARBON R	RN72K1J-000JE	1	435030004R1
R4614	C-CARBON R	RN72K1J-000JE	1	435030004R1
R4615	C-CARBON R	RN72K1J-000JE	1	435030004R1
R4616	C-CARBON R	RN72K1J-000JE	1	435030004R1
R4617	C-CARBON R	RN72K1J-000JE	1	435030004R1
R4618	C-CARBON R	RN72K1J-000JE	1	435030004R1
R4619	C-CARBON R	RN72K1J-000JE	1	435030004R1
R4620	C-CARBON R	RN72K1J-000JE	1	435030004R1
R4625	C-CARBON R	RN72K1J-000JE	1	435030004R1
R4626	C-CARBON R	RN72K1J-000JE	1	435030004R1
R4627	C-CARBON R	RN72K1J-000JE	1	435030004R1
R4628	C-CARBON R	RN72K1J-000JE	1	435030004R1
R4629	C-CARBON R	RN72K1J-000JE	1	435030004R1
R6000	C-CARBON R	RN72K1J-562JE	1	435035624R1
R6001	C-CARBON R	RN72K1J-562JE	1	435035624R1
R6002	C-CARBON R	RN72K1J-562JE	1	435035624R1
R6003	C-CARBON R	RN72K1J-562JE	1	435035624R1
R6004	C-CARBON R	RN72K1J-562JE	1	435035624R1
R6005	C-CARBON R	RN72K1J-562JE	1	435035624R1
R6006	C-CARBON R	RN72K1J-562JE	1	435035624R1
R6010	C-CARBON R	RN72K1J-472JE	1	435034724R1
R6011	C-CARBON R	RN72K1J-472JE	1	435034724R1
R6012	C-CARBON R	RN72K1J-472JE	1	435034724R1
R6013	C-CARBON R	RN72K1J-472JE	1	435034724R1
R6014	C-CARBON R	RN72K1J-472JE	1	435034724R1
R6015	C-CARBON R	RN72K1J-472JE	1	435034724R1
R6016	C-CARBON R	RN72K1J-472JE	1	435034724R1
R6020	C-CARBON R	RN72K1J-202JE	1	435032024R1
R6021	C-CARBON R	RN72K1J-202JE	1	435032024R1
R6022	C-CARBON R	RN72K1J-202JE	1	435032024R1
R6023	C-CARBON R	RN72K1J-272JE	1	435032724R1
R6024	C-CARBON R	RN72K1J-272JE	1	435032724R1
R6025	C-CARBON R	RN72K1J-272JE	1	435032724R1
R6026	C-CARBON R	RN72K1J-272JE	1	435032724R1
R6100	METAL PR	MPR5W+5W 0R22	1	4000233
R6100 or	METAL P R	RF-5EGPJR22	(1)	4000244
R6101	METAL PR	MPR5W+5W 0R22	1	4000233
R6101 or	METAL P R	RF-5EGPJR22	(1)	4000244
R6102	METAL PR	MPR5W+5W 0R22	1	4000233
R6102 or	METAL P R	RF-5EGPJR22	(1)	4000244

R6103	METAL PR	MPR5W+5W 0R22	1	4000233
R6103 or	METAL P R	RF-5EGPJR22	(1)	4000244
R6104	METAL PR	MPR5W+5W 0R22	1	4000233
R6104 or	METAL P R	RF-5EGPJR22	(1)	4000244
R6105	METAL PR	MPR5W+5W 0R22	1	4000233
R6105 or	METAL P R	RF-5EGPJR22	(1)	4000244
R6106	METAL PR	MPR5W+5W 0R22	1	4000233
R6106 or	METAL P R	RF-5EGPJR22	(1)	4000244
R6140	C-CARBON R	RN72K1J-563JE	1	435035634R1
R6141	C-CARBON R	RN72K1J-563JE	1	435035634R1
R6142	C-CARBON R	RN72K1J-563JE	1	435035634R1
R6143	C-CARBON R	RN72K1J-563JE	1	435035634R1
R6144	C-CARBON R	RN72K1J-563JE	1	435035634R1
R6145	C-CARBON R	RN72K1J-563JE	1	435035634R1
R6146	C-CARBON R	RN72K1J-563JE	1	435035634R1
R6150	C-CARBON R	RN72K1J-103JE	1	435031034R1
R6151	C-CARBON R	RN72K1J-103JE	1	435031034R1
R6152	C-CARBON R	RN72K1J-103JE	1	435031034R1
R6153	C-CARBON R	RN72K1J-103JE	1	435031034R1
R6154	C-CARBON R	RN72K1J-103JE	1	435031034R1
R6155	C-CARBON R	RN72K1J-103JE	1	435031034R1
R6156	C-CARBON R	RN72K1J-103JE	1	435031034R1
R6160	C-CARBON R	RN72K1J-333JE	1	435033334R1
R6161	C-CARBON R	RN72K1J-333JE	1	435033334R1
R6162	C-CARBON R	RN72K1J-333JE	1	435033334R1
R6163	C-CARBON R	RN72K1J-333JE	1	435033334R1
R6164	C-CARBON R	RN72K1J-333JE	1	435033334R1
R6165	C-CARBON R	RN72K1J-333JE	1	435033334R1
R6166	C-CARBON R	RN72K1J-333JE	1	435033334R1
R6170	C-CARBON R	RN72K1J-473JE	1	435034734R1
R6171	C-CARBON R	RN72K1J-473JE	1	435034734R1
R6172	C-CARBON R	RN72K1J-473JE	1	435034734R1
R6173	C-CARBON R	RN72K1J-473JE	1	435034734R1
R6174	C-CARBON R	RN72K1J-473JE	1	435034734R1
R6175	C-CARBON R	RN72K1J-473JE	1	435034734R1
R6176	C-CARBON R	RN72K1J-473JE	1	435034734R1
R6180	C-CARBON R	RN72K1J-473JE	1	435034734R1
R6181	C-CARBON R	RN72K1J-473JE	1	435034734R1
R6182	C-CARBON R	RN72K1J-473JE	1	435034734R1
R6183	C-CARBON R	RN72K1J-473JE	1	435034734R1
R6184	C-CARBON R	RN72K1J-473JE	1	435034734R1
R6185	C-CARBON R	RN72K1J-473JE	1	435034734R1
R6186	C-CARBON R	RN72K1J-473JE	1	435034734R1
R6401	METAL R	RNU1/2WCJ-0.1	1	453531094T
R6402	C-CARBON R	RN72K1J-102JE	1	435031024R1
R6403	C-CARBON R	RN72K1J-473JE	1	435034734R1
R6406	METAL O R	RS1/2WBJ-33	1	443523304T
R6430	METAL O R	RS1/2WBJ-10	1	443521004T
R6431	METAL O R	RS1/2WBJ-10	1	443521004T
R6432	METAL O R	RS1/2WBJ-10	1	443521004T
R6433	METAL O R	RS1/2WBJ-10	1	443521004T
R6434	METAL O R	RS1/2WBJ-10	1	443521004T
R6435	METAL O R	RS1/2WBJ-10	1	443521004T
R6436	METAL O R	RS1/2WBJ-10	1	443521004T
R6451	C-CARBON R	RN72K1J-333JE	1	435033334R1
R6452	C-CARBON R	RN72K1J-103JE	1	435031034R1
R6453	C-CARBON R	RN72K1J-223JE	1	435032234R1
R6454	C-CARBON R	RN72K1J-473JE	1	435034734R1
R6455	C-CARBON R	RN72K1J-103JE	1	435031034R1
R6456	C-CARBON R	RN72K1J-223JE	1	435032234R1
R6457	C-CARBON R	RN72K1J-223JE	1	435032234R1
R6458	C-CARBON R	RN72K1J-472JE	1	435034724R1
R6459	C-CARBON R	RN72K1J-562JE	1	435035624R1
R6460	C-CARBON R	RN72K1J-473JE	1	435034734R1
R6640	METAL R	RNU1WCJ-8.2	1	453630824T
R6641	METAL R	RNU1WCJ-8.2	1	453630824T
R6642	METAL R	RNU1WCJ-8.2	1	453630824T
R6643	METAL R	RNU1WCJ-8.2	1	453630824T
R6644	METAL R	RNU1WCJ-8.2	1	453630824T
R6645	METAL R	RNU1WCJ-8.2	1	453630824T
R6646	METAL R	RNU1WCJ-8.2	1	453630824T
R6700	C-CARBON R	RN72K1J-000JE	1	435030004R1
R6701	C-CARBON R	RN72K1J-000JE	1	435030004R1
R6702	C-CARBON R	RN72K1J-000JE	1	435030004R1
R6703	C-CARBON R	RN72K1J-000JE	1	435030004R1
R6704	C-CARBON R	RN72K1J-000JE	1	435030004R1

R6705	C-CARBON R	RN72K1J-000JE	1	435030004R1	
R6706	C-CARBON R	RN72K1J-000JE	1	435030004R1	
R6707	C-CARBON R	RN72K1J-000JE	1	435030004R1	
[SW TRM]					
F6401A	FUSE HOLDER	SN5051	1	250113	!
F6401B	FUSE HOLDER	SN5051	1	250113	!
F6402A	FUSE HOLDER	SN5051	1	250113	!
F6402B	FUSE HOLDER	SN5051	1	250113	!
P101B	SOCKET	NSCT-9P2102	1	25052205	
P4001	PIN JACK	NPJ-2PDWR558	1	25045776	
P4002	PIN JACK	NPJ-4PDWR690	1	25045922	
P4003	PIN JACK	NPJ-4PDWWR624	1	25045845	
P4004	PIN JACK	NPJ-4PDWWR624	1	25045845	
P4009	PIN JACK	NPJ-4PDWWR624	1	25045845	
P4010	PIN JACK	NPJ-2PDP686	1	25045918	
P501	SOCKET AS	NSAS-3P2095	1	2009991284UL	
P501A	WIRE HOL	NSCT-3P874	1	25051087	
P5502B	PLUG	NPLG-20P0975	1	25056025	
P5503B	PLUG	NPLG-15P0970	1	25056020	
P5504B	PLUG	NPLG-5P0960	1	25056010	
P5505A	CRIMP AS	CRIMP AS	1	2069955250UL	
P5508	TRM-423(SCREW)	NEJITANSI ST3	1	25060495	
P5510B	TRM	NTM-1P232(M1700)	1	25060301	
P6000B	PLUG	NPLG-9P0964	1	25056014	
P6001B	PLUG	NPLG-9P0964	1	25056014	
P6002B	PLUG	NPLG-9P0964	1	25056014	
P6003B	PLUG	NPLG-9P0964	1	25056014	
P6004B	PLUG	NPLG-9P0964	1	25056014	
P6005B	PLUG	NPLG-9P0964	1	25056014	
P6006B	PLUG	NPLG-9P0964	1	25056014	
P6007B	TRM	NTM-1P232(M1700)	1	25060301	
P6008B	TRM	NTM-1P232(M1700)	1	25060301	
P6009B	TRM	NTM-1P232(M1700)	1	25060301	
P6010B	TRM	NTM-1P232(M1700)	1	25060301	
P6011B	RETAINER	(BUS)	1	27142306A	N
P603	SOCKET AS	NSAS-9P2223	1	2009991412UL	
P603A	WIRE HOL	NSCT-9P900	1	25051113	
P6080	PLUG	NPLG-2P29	1	25055038	
P6081	PLUG	NPLG-2P29	1	25055038	
P6082	PLUG	NPLG-2P29	1	25055038	
P6083	PLUG	NPLG-2P29	1	25055038	
P6084	PLUG	NPLG-2P29	1	25055038	
P6085	PLUG	NPLG-2P29	1	25055038	
P6086	PLUG	NPLG-2P29	1	25055038	
P6100	HOLDER	HOLDER(CLAMP)	1	27190540-1	
P6101	HOLDER	HOLDER(CLAMP)	1	27190540-1	
P6102	HOLDER	HOLDER(CLAMP)	1	27190540-1	
P6103	HOLDER	HOLDER(CLAMP)	1	27190540-1	
P6104	HOLDER	HOLDER(CLAMP)	1	27190540-1	
P6105	HOLDER	(CRAMP) UA-0 V0	1	27190608-1	
P6200A	SOCKET AS	NSAS-26P2238	1	2009991425UL	
P6201	PLUG	NPLG-5P152	1	25055168	
P6204	WS CLAMP	CB-71683(L=50)	1	260261	
P6205	WS CLAMP	CB-71683(L=50)	1	260261	
P6400B	CRIMP AS	CRIMP AS	1	2069925200UL	
P6401A	CRIMP AS	CRIMP AS	1	2069925119UL	
P6402A	CRIMP AS	CRIMP AS	1	2069925188UL	
P6600A	SOCKET AS	NSAS-14P2234	1	2009991421UL	
RL643	RELAY	NRL-1P10A-DC12-196	1	25065707	
RL643 or	RELAY	NRL-1P10A-DC12-197	(1)	25065708	
RL643 or	RELAY	NRL-1P10A-DC12-198	(1)	25065709	
RL644	RELAY	NRL-1P10A-DC12-196	1	25065707	
RL644 or	RELAY	NRL-1P10A-DC12-197	(1)	25065708	
RL644 or	RELAY	NRL-1P10A-DC12-198	(1)	25065709	
U002					
		BAAMP-1367-1B			: NSP
CIRCUIT NO.	PART NAME	DESCRIPTION	Q'TY	PART NO. (SN)	REMARKS
[SEMI CONDUCTOR]					
Q5500	TR	INA6006AP1-T111	1	2217980R2	
Q5510	TR	INA6006AP1-T111	1	2217980R2	
Q5520	TR	INC6006AP1-T111	1	2217990R2	
Q5530	TR	INC6006AP1-T111	1	2217990R2	

[RESISTOR]				
R5500	NF CARBON R	R25J-220	1	415472214T
R5510	NF CARBON R	R25J-220	1	415472214T
R5520	NF CARBON R	R25J-220	1	415472214T
R5530	NF CARBON R	R25J-220	1	415472214T

[SW TRM]				
P5000A	SOCKET	9210B-1-06Z140-PT1	1	25053513
P5001A	SOCKET	9210B-1-03Z140-PT1	1	25053266

U003 : NSP

BACLA-1328-1A

CIRCUIT NO.	PART NAME	DESCRIPTION	Q'TY	PART NO. (SN)	REMARKS
[SEMI CONDUCTOR]					
D5000	ZENER D	DZ2J056M0L	1	224760560R2	
D5000 or	ZENER D	UDZS5.6B	(1)	224550560R2	
D5001	ZENER D	DZ2J056M0L	1	224760560R2	
D5001 or	ZENER D	UDZS5.6B	(1)	224550560R2	
D5002	ZENER D	DZ2J056M0L	1	224760560R2	
D5002 or	ZENER D	UDZS5.6B	(1)	224550560R2	
D5003	ZENER D	DZ2J056M0L	1	224760560R2	
D5003 or	ZENER D	UDZS5.6B	(1)	224550560R2	
D5004	ZENER D	DZ2J056M0L	1	224760560R2	
D5004 or	ZENER D	UDZS5.6B	(1)	224550560R2	
D5005	ZENER D	DZ2J056M0L	1	224760560R2	
D5005 or	ZENER D	UDZS5.6B	(1)	224550560R2	
D5006	ZENER D	DZ2J056M0L	1	224760560R2	
D5006 or	ZENER D	UDZS5.6B	(1)	224550560R2	
Q5000	TR	2SC2713-BL	1	2213136R2	
Q5001	TR	2SC2713-BL	1	2213136R2	
Q5002	TR	2SC2713-BL	1	2213136R2	
Q5003	TR	2SC2713-BL	1	2213136R2	
Q5004	TR	2SC2713-BL	1	2213136R2	
Q5005	TR	2SC2713-BL	1	2213136R2	
Q5006	TR	2SC2713-BL	1	2213136R2	
Q5010	TR	2SC2713-BL	1	2213136R2	
Q5011	TR	2SC2713-BL	1	2213136R2	
Q5012	TR	2SC2713-BL	1	2213136R2	
Q5013	TR	2SC2713-BL	1	2213136R2	
Q5014	TR	2SC2713-BL	1	2213136R2	
Q5015	TR	2SC2713-BL	1	2213136R2	
Q5016	TR	2SC2713-BL	1	2213136R2	
Q5030	TR	2SA1200-Y(2LONK_ZE)	1	2217584R2	
Q5030 or	TR	INA6006AP1-T111	(1)	2217980R2	
Q5031	TR	2SA1200-Y(2LONK_ZE)	1	2217584R2	
Q5031 or	TR	INA6006AP1-T111	(1)	2217980R2	
Q5032	TR	2SA1200-Y(2LONK_ZE)	1	2217584R2	
Q5032 or	TR	INA6006AP1-T111	(1)	2217980R2	
Q5033	TR	2SA1200-Y(2LONK_ZE)	1	2217584R2	
Q5033 or	TR	INA6006AP1-T111	(1)	2217980R2	
Q5034	TR	2SA1200-Y(2LONK_ZE)	1	2217584R2	
Q5034 or	TR	INA6006AP1-T111	(1)	2217980R2	
Q5035	TR	2SA1200-Y(2LONK_ZE)	1	2217584R2	
Q5035 or	TR	INA6006AP1-T111	(1)	2217980R2	
Q5036	TR	2SA1200-Y(2LONK_ZE)	1	2217584R2	
Q5036 or	TR	INA6006AP1-T111	(1)	2217980R2	
Q5040	TR	2SA1200-Y(2LONK_ZE)	1	2217584R2	
Q5040 or	TR	INA6006AP1-T111	(1)	2217980R2	
Q5041	TR	2SA1200-Y(2LONK_ZE)	1	2217584R2	
Q5041 or	TR	INA6006AP1-T111	(1)	2217980R2	
Q5042	TR	2SA1200-Y(2LONK_ZE)	1	2217584R2	
Q5042 or	TR	INA6006AP1-T111	(1)	2217980R2	
Q5043	TR	2SA1200-Y(2LONK_ZE)	1	2217584R2	
Q5043 or	TR	INA6006AP1-T111	(1)	2217980R2	
Q5044	TR	2SA1200-Y(2LONK_ZE)	1	2217584R2	
Q5044 or	TR	INA6006AP1-T111	(1)	2217980R2	
Q5045	TR	2SA1200-Y(2LONK_ZE)	1	2217584R2	
Q5045 or	TR	INA6006AP1-T111	(1)	2217980R2	
Q5046	TR	2SA1200-Y(2LONK_ZE)	1	2217584R2	
Q5046 or	TR	INA6006AP1-T111	(1)	2217980R2	
Q5050	TR	2SC2713-BL	1	2213136R2	
Q5051	TR	2SC2713-BL	1	2213136R2	
Q5052	TR	2SC2713-BL	1	2213136R2	
Q5053	TR	2SC2713-BL	1	2213136R2	

Q5054	TR	2SC2713-BL	1	2213136R2
Q5055	TR	2SC2713-BL	1	2213136R2
Q5056	TR	2SC2713-BL	1	2213136R2
Q5063	TR	2SA1200-Y(2LONK_ZE)	1	2217584R2
Q5063 or	TR	INA6006AP1-T111	(1)	2217980R2
Q5064	TR	2SA1200-Y(2LONK_ZE)	1	2217584R2
Q5064 or	TR	INA6006AP1-T111	(1)	2217980R2
Q5065	TR	2SA1200-Y(2LONK_ZE)	1	2217584R2
Q5065 or	TR	INA6006AP1-T111	(1)	2217980R2
Q5066	TR	2SA1200-Y(2LONK_ZE)	1	2217584R2
Q5066 or	TR	INA6006AP1-T111	(1)	2217980R2
Q5073	TR	2SC2880-Y(2LONK_ZE)	1	2217594R2
Q5073 or	TR	INC6006AP1-T111	(1)	2217990R2
Q5074	TR	2SC2880-Y(2LONK_ZE)	1	2217594R2
Q5074 or	TR	INC6006AP1-T111	(1)	2217990R2
Q5075	TR	2SC2880-Y(2LONK_ZE)	1	2217594R2
Q5075 or	TR	INC6006AP1-T111	(1)	2217990R2
Q5076	TR	2SC2880-Y(2LONK_ZE)	1	2217594R2
Q5076 or	TR	INC6006AP1-T111	(1)	2217990R2
Q5250	TR	2SA1930(ONK_Q)	1	2203000
Q5251	TR	2SA1930(ONK_Q)	1	2203000
Q5252	TR	2SA1930(ONK_Q)	1	2203000
Q5253	TR	2SA1930(ONK_Q)	1	2203000
Q5253 or	TR	KTB1369-Y	(1)	2203424
Q5254	TR	2SA1930(ONK_Q)	1	2203000
Q5254 or	TR	KTB1369-Y	(1)	2203424
Q5255	TR	2SA1930(ONK_Q)	1	2203000
Q5255 or	TR	KTB1369-Y	(1)	2203424
Q5256	TR	2SA1930(ONK_Q)	1	2203000
Q5256 or	TR	KTB1369-Y	(1)	2203424
Q5260	TR	2SC5171(ONK_Q)	1	2203010
Q5261	TR	2SC5171(ONK_Q)	1	2203010
Q5262	TR	2SC5171(ONK_Q)	1	2203010
Q5263	TR	2SC5171(ONK_Q)	1	2203010
Q5263 or	TR	KTD2061-Y	(1)	2203434
Q5264	TR	2SC5171(ONK_Q)	1	2203010
Q5264 or	TR	KTD2061-Y	(1)	2203434
Q5265	TR	2SC5171(ONK_Q)	1	2203010
Q5265 or	TR	KTD2061-Y	(1)	2203434
Q5266	TR	2SC5171(ONK_Q)	1	2203010
Q5266 or	TR	KTD2061-Y	(1)	2203434
Q5410	TR	2SC2412K-R	1	2214653R2
Q5410 or	TR	KTC3875-GR	(1)	2216175R2
Q5411	TR	2SC2412K-R	1	2214653R2
Q5411 or	TR	KTC3875-GR	(1)	2216175R2
Q5412	TR	2SC2412K-R	1	2214653R2
Q5412 or	TR	KTC3875-GR	(1)	2216175R2
Q5413	TR	2SC2412K-R	1	2214653R2
Q5413 or	TR	KTC3875-GR	(1)	2216175R2
Q5414	TR	2SC2412K-R	1	2214653R2
Q5414 or	TR	KTC3875-GR	(1)	2216175R2
Q5415	TR	2SC2412K-R	1	2214653R2
Q5415 or	TR	KTC3875-GR	(1)	2216175R2
Q5416	TR	2SC2412K-R	1	2214653R2
Q5416 or	TR	KTC3875-GR	(1)	2216175R2
Q5430	TR	2SC2880-Y(2LONK_ZE)	1	2217594R2
Q5430 or	TR	INC6006AP1-T111	(1)	2217990R2
Q5431	TR	2SC2880-Y(2LONK_ZE)	1	2217594R2
Q5431 or	TR	INC6006AP1-T111	(1)	2217990R2
Q5432	TR	2SC2880-Y(2LONK_ZE)	1	2217594R2
Q5432 or	TR	INC6006AP1-T111	(1)	2217990R2
Q5433	TR	2SC2880-Y(2LONK_ZE)	1	2217594R2
Q5433 or	TR	INC6006AP1-T111	(1)	2217990R2
Q5434	TR	2SC2880-Y(2LONK_ZE)	1	2217594R2
Q5434 or	TR	INC6006AP1-T111	(1)	2217990R2
Q5435	TR	2SC2880-Y(2LONK_ZE)	1	2217594R2
Q5435 or	TR	INC6006AP1-T111	(1)	2217990R2
Q5436	TR	2SC2880-Y(2LONK_ZE)	1	2217594R2
Q5436 or	TR	INC6006AP1-T111	(1)	2217990R2
Q5440	TR	2SA1200-Y(2LONK_ZE)	1	2217584R2
Q5440 or	TR	INA6006AP1-T111	(1)	2217980R2
Q5441	TR	2SA1200-Y(2LONK_ZE)	1	2217584R2
Q5441 or	TR	INA6006AP1-T111	(1)	2217980R2
Q5442	TR	2SA1200-Y(2LONK_ZE)	1	2217584R2
Q5442 or	TR	INA6006AP1-T111	(1)	2217980R2
Q5443	TR	2SA1200-Y(2LONK_ZE)	1	2217584R2

Q5443 or	TR	INA6006AP1-T111	(1)	2217980R2
Q5444	TR	2SA1200-Y(2LONK_ZE)	1	2217584R2
Q5444 or	TR	INA6006AP1-T111	(1)	2217980R2
Q5445	TR	2SA1200-Y(2LONK_ZE)	1	2217584R2
Q5445 or	TR	INA6006AP1-T111	(1)	2217980R2
Q5446	TR	2SA1200-Y(2LONK_ZE)	1	2217584R2
Q5446 or	TR	INA6006AP1-T111	(1)	2217980R2
Q5460	TR	2SA1037AK-R	1	2217043R2
Q5461	TR	2SA1037AK-R	1	2217043R2
Q5462	TR	2SA1037AK-R	1	2217043R2
Q5463	TR	2SA1037AK-R	1	2217043R2
Q5464	TR	2SA1037AK-R	1	2217043R2
Q5465	TR	2SA1037AK-R	1	2217043R2
Q5466	TR	2SA1037AK-R	1	2217043R2
[TRANS COIL]				
L5400	FR CORE	---	1	5597-45502
L5401	FR CORE	---	1	5597-45502
L5402	FR CORE	---	1	5597-45502
L5403	FR CORE	---	1	5597-45502
L5404	FR CORE	---	1	5597-45502
L5405	FR CORE	---	1	5597-45502
L5406	FR CORE	---	1	5597-45502
L5410	FR CORE	---	1	5597-45502
L5411	FR CORE	---	1	5597-45502
L5412	FR CORE	---	1	5597-45502
L5413	FR CORE	---	1	5597-45502
L5414	FR CORE	---	1	5597-45502
L5415	FR CORE	---	1	5597-45502
L5416	FR CORE	---	1	5597-45502
[CAPACITOR]				
C5000	UPZ C	2AUPZTF221JE	1	376332214T
C5001	UPZ C	2AUPZTF221JE	1	376332214T
C5002	UPZ C	2AUPZTF221JE	1	376332214T
C5003	UPZ C	2AUPZTF221JE	1	376332214T
C5004	UPZ C	2AUPZTF221JE	1	376332214T
C5005	UPZ C	2AUPZTF221JE	1	376332214T
C5006	UPZ C	2AUPZTF221JE	1	376332214T
C5010	UTSP C	CE04W50V 47M(UTSP)	1	397584707AT
C5011	UTSP C	CE04W50V 47M(UTSP)	1	397584707AT
C5012	UTSP C	CE04W50V 47M(UTSP)	1	397584707AT
C5013	UTSP C	CE04W50V 47M(UTSP)	1	397584707AT
C5014	UTSP C	CE04W50V 47M(UTSP)	1	397584707AT
C5015	UTSP C	CE04W50V 47M(UTSP)	1	397584707AT
C5016	UTSP C	CE04W50V 47M(UTSP)	1	397584707AT
C5020	UTSP C	CE04W50V-10M(UTSP)	1	397581007AT
C5021	UTSP C	CE04W50V-10M(UTSP)	1	397581007AT
C5022	UTSP C	CE04W50V-10M(UTSP)	1	397581007AT
C5023	UTSP C	CE04W50V-10M(UTSP)	1	397581007AT
C5024	UTSP C	CE04W50V-10M(UTSP)	1	397581007AT
C5025	UTSP C	CE04W50V-10M(UTSP)	1	397581007AT
C5026	UTSP C	CE04W50V-10M(UTSP)	1	397581007AT
C5040	UTSP C	CE04W10V-470M(UTSP)	1	397534717T
C5041	UTSP C	CE04W10V-470M(UTSP)	1	397534717T
C5042	UTSP C	CE04W10V-470M(UTSP)	1	397534717T
C5043	UTSP C	CE04W10V-470M(UTSP)	1	397534717T
C5044	UTSP C	CE04W10V-470M(UTSP)	1	397534717T
C5045	UTSP C	CE04W10V-470M(UTSP)	1	397534717T
C5046	UTSP C	CE04W10V-470M(UTSP)	1	397534717T
C5050	UTSP C	CE04W50V 47M(UTSP)	1	397584707AT
C5051	UTSP C	CE04W50V 47M(UTSP)	1	397584707AT
C5052	UTSP C	CE04W50V 47M(UTSP)	1	397584707AT
C5053	UTSP C	CE04W50V 47M(UTSP)	1	397584707AT
C5054	UTSP C	CE04W50V 47M(UTSP)	1	397584707AT
C5055	UTSP C	CE04W50V 47M(UTSP)	1	397584707AT
C5056	UTSP C	CE04W50V 47M(UTSP)	1	397584707AT
C5080	CERA C	CC45SL50V-020C	1	345020201T
C5081	CERA C	CC45SL50V-020C	1	345020201T
C5082	CERA C	CC45SL50V-020C	1	345020201T
C5083	CERA C	CC45SL50V-040C	1	345020401T
C5084	CERA C	CC45SL50V-040C	1	345020401T
C5085	CERA C	CC45SL50V-040C	1	345020401T
C5086	CERA C	CC45SL50V-040C	1	345020401T
C5090	UPZ C	2AUPZTF101JE	1	376331014T
C5091	UPZ C	2AUPZTF101JE	1	376331014T
C5092	UPZ C	2AUPZTF101JE	1	376331014T
C5093	UPZ C	2AUPZTF101JE	1	376331014T

C5094	UPZ C	2AUPZTF101JE	1	376331014T
C5095	UPZ C	2AUPZTF101JE	1	376331014T
C5096	UPZ C	2AUPZTF101JE	1	376331014T
C5100	VR C	CE04W 100V-22M(VR)	1	394692207T
C5101	VR C	CE04W 100V-22M(VR)	1	394692207T
C5102	VR C	CE04W 100V-22M(VR)	1	394692207T
C5103	VR C	CE04W 100V-22M(VR)	1	394692207T
C5104	VR C	CE04W 100V-22M(VR)	1	394692207T
C5105	VR C	CE04W 100V-22M(VR)	1	394692207T
C5106	VR C	CE04W 100V-22M(VR)	1	394692207T
C5110	VR C	CE04W 100V-22M(VR)	1	394692207T
C5111	VR C	CE04W 100V-22M(VR)	1	394692207T
C5112	VR C	CE04W 100V-22M(VR)	1	394692207T
C5113	VR C	CE04W 100V-22M(VR)	1	394692207T
C5114	VR C	CE04W 100V-22M(VR)	1	394692207T
C5115	VR C	CE04W 100V-22M(VR)	1	394692207T
C5116	VR C	CE04W 100V-22M(VR)	1	394692207T
C5440	UTSP C	CE04W50V-22M(UTSP)	1	397582207AT
C5441	UTSP C	CE04W50V-22M(UTSP)	1	397582207AT
C5442	UTSP C	CE04W50V-22M(UTSP)	1	397582207AT
C5443	UTSP C	CE04W50V-22M(UTSP)	1	397582207AT
C5444	UTSP C	CE04W50V-22M(UTSP)	1	397582207AT
C5445	UTSP C	CE04W50V-22M(UTSP)	1	397582207AT
C5446	UTSP C	CE04W50V-22M(UTSP)	1	397582207AT
[RESISTOR]				
R5000	C-CARBON R	RN72K1J-222JE	1	435032224R1
R5001	C-CARBON R	RN72K1J-222JE	1	435032224R1
R5002	C-CARBON R	RN72K1J-222JE	1	435032224R1
R5003	C-CARBON R	RN72K1J-222JE	1	435032224R1
R5004	C-CARBON R	RN72K1J-222JE	1	435032224R1
R5005	C-CARBON R	RN72K1J-222JE	1	435032224R1
R5006	C-CARBON R	RN72K1J-222JE	1	435032224R1
R5010	C-CARBON R	RN72K1J-563JE	1	435035634R1
R5011	C-CARBON R	RN72K1J-563JE	1	435035634R1
R5012	C-CARBON R	RN72K1J-563JE	1	435035634R1
R5013	C-CARBON R	RN72K1J-333JE	1	435033334R1
R5014	C-CARBON R	RN72K1J-333JE	1	435033334R1
R5015	C-CARBON R	RN72K1J-333JE	1	435033334R1
R5016	C-CARBON R	RN72K1J-333JE	1	435033334R1
R5020	C-CARBON R	RN72K1J-331JE	1	435033314R1
R5021	C-CARBON R	RN72K1J-331JE	1	435033314R1
R5022	C-CARBON R	RN72K1J-331JE	1	435033314R1
R5023	C-CARBON R	RN72K1J-331JE	1	435033314R1
R5024	C-CARBON R	RN72K1J-331JE	1	435033314R1
R5025	C-CARBON R	RN72K1J-331JE	1	435033314R1
R5026	C-CARBON R	RN72K1J-331JE	1	435033314R1
R5030	NF CARBON R	R25J-56K	1	415475634T
R5031	NF CARBON R	R25J-56K	1	415475634T
R5032	NF CARBON R	R25J-56K	1	415475634T
R5033	NF CARBON R	R25J-33K	1	415473334T
R5034	NF CARBON R	R25J-33K	1	415473334T
R5035	NF CARBON R	R25J-33K	1	415473334T
R5036	NF CARBON R	R25J-33K	1	415473334T
R5040	C-CARBON R	RN72K1J-182JE	1	435031824R1
R5041	C-CARBON R	RN72K1J-182JE	1	435031824R1
R5042	C-CARBON R	RN72K1J-182JE	1	435031824R1
R5043	C-CARBON R	RN72K1J-102JE	1	435031024R1
R5044	C-CARBON R	RN72K1J-102JE	1	435031024R1
R5045	C-CARBON R	RN72K1J-102JE	1	435031024R1
R5046	C-CARBON R	RN72K1J-102JE	1	435031024R1
R5050	C-CARBON R	RN72K1J-822JE	1	435038224R1
R5051	C-CARBON R	RN72K1J-822JE	1	435038224R1
R5052	C-CARBON R	RN72K1J-822JE	1	435038224R1
R5053	C-CARBON R	RN72K1J-822JE	1	435038224R1
R5054	C-CARBON R	RN72K1J-822JE	1	435038224R1
R5055	C-CARBON R	RN72K1J-822JE	1	435038224R1
R5056	C-CARBON R	RN72K1J-822JE	1	435038224R1
R5060	C-CARBON R	RN72K1J-272JE	1	435032724R1
R5061	C-CARBON R	RN72K1J-272JE	1	435032724R1
R5062	C-CARBON R	RN72K1J-272JE	1	435032724R1
R5063	C-CARBON R	RN72K1J-272JE	1	435032724R1
R5064	C-CARBON R	RN72K1J-272JE	1	435032724R1
R5065	C-CARBON R	RN72K1J-272JE	1	435032724R1
R5066	C-CARBON R	RN72K1J-272JE	1	435032724R1
R5080	NF CARBON R	R25J-1.0K	1	415471024T
R5081	NF CARBON R	R25J-1.0K	1	415471024T

R5082	NF CARBON R	R25J-1.0K	1	415471024T
R5083	NF CARBON R	R25J-1.0K	1	415471024T
R5084	NF CARBON R	R25J-1.0K	1	415471024T
R5085	NF CARBON R	R25J-1.0K	1	415471024T
R5086	NF CARBON R	R25J-1.0K	1	415471024T
R5090	C-CARBON R	RN72K2E-104JE	1	435221044R1
R5091	C-CARBON R	RN72K2E-104JE	1	435221044R1
R5092	C-CARBON R	RN72K2E-104JE	1	435221044R1
R5093	C-CARBON R	RN72K2E-104JE	1	435221044R1
R5094	C-CARBON R	RN72K2E-104JE	1	435221044R1
R5095	C-CARBON R	RN72K2E-104JE	1	435221044R1
R5096	C-CARBON R	RN72K2E-104JE	1	435221044R1
R5100	C-CARBON R	RN72K1J-104JE	1	435031044R1
R5101	C-CARBON R	RN72K1J-104JE	1	435031044R1
R5102	C-CARBON R	RN72K1J-104JE	1	435031044R1
R5103	C-CARBON R	RN72K1J-104JE	1	435031044R1
R5104	C-CARBON R	RN72K1J-104JE	1	435031044R1
R5105	C-CARBON R	RN72K1J-104JE	1	435031044R1
R5106	C-CARBON R	RN72K1J-104JE	1	435031044R1
R5110	C-CARBON R	RN72K1J-222JE	1	435032224R1
R5111	C-CARBON R	RN72K1J-222JE	1	435032224R1
R5112	C-CARBON R	RN72K1J-222JE	1	435032224R1
R5113	C-CARBON R	RN72K1J-222JE	1	435032224R1
R5114	C-CARBON R	RN72K1J-222JE	1	435032224R1
R5115	C-CARBON R	RN72K1J-222JE	1	435032224R1
R5116	C-CARBON R	RN72K1J-222JE	1	435032224R1
R5120	C-CARBON R	RN72K1J-222JE	1	435032224R1
R5121	C-CARBON R	RN72K1J-222JE	1	435032224R1
R5122	C-CARBON R	RN72K1J-222JE	1	435032224R1
R5123	C-CARBON R	RN72K1J-222JE	1	435032224R1
R5124	C-CARBON R	RN72K1J-222JE	1	435032224R1
R5125	C-CARBON R	RN72K1J-222JE	1	435032224R1
R5126	C-CARBON R	RN72K1J-222JE	1	435032224R1
R5130	NF CARBON R	R25J-18K	1	415471834T
R5131	NF CARBON R	R25J-18K	1	415471834T
R5132	NF CARBON R	R25J-18K	1	415471834T
R5133	NF CARBON R	R25J-33K	1	415473334T
R5134	NF CARBON R	R25J-33K	1	415473334T
R5135	NF CARBON R	R25J-33K	1	415473334T
R5136	NF CARBON R	R25J-33K	1	415473334T
R5140	NF CARBON R	R25J-820	1	415478214T
R5141	NF CARBON R	R25J-820	1	415478214T
R5142	NF CARBON R	R25J-820	1	415478214T
R5143	NF CARBON R	R25J-820	1	415478214T
R5144	NF CARBON R	R25J-820	1	415478214T
R5145	NF CARBON R	R25J-820	1	415478214T
R5146	NF CARBON R	R25J-820	1	415478214T
R5150	NF CARBON R	R25J-1.0K	1	415471024T
R5151	NF CARBON R	R25J-1.0K	1	415471024T
R5152	NF CARBON R	R25J-1.0K	1	415471024T
R5153	NF CARBON R	R25J-1.0K	1	415471024T
R5154	NF CARBON R	R25J-1.0K	1	415471024T
R5155	NF CARBON R	R25J-1.0K	1	415471024T
R5156	NF CARBON R	R25J-1.0K	1	415471024T
R5163	NF CARBON R	R25J-220	1	415472214T
R5164	NF CARBON R	R25J-220	1	415472214T
R5165	NF CARBON R	R25J-220	1	415472214T
R5166	NF CARBON R	R25J-220	1	415472214T
R5170	NF CARBON R	R25J-820	1	415478214T
R5171	NF CARBON R	R25J-820	1	415478214T
R5172	NF CARBON R	R25J-820	1	415478214T
R5173	NF CARBON R	R25J-820	1	415478214T
R5174	NF CARBON R	R25J-820	1	415478214T
R5175	NF CARBON R	R25J-820	1	415478214T
R5176	NF CARBON R	R25J-820	1	415478214T
R5180	NF CARBON R	R25J-10	1	415471004T
R5181	NF CARBON R	R25J-10	1	415471004T
R5182	NF CARBON R	R25J-10	1	415471004T
R5183	NF CARBON R	R25J-10	1	415471004T
R5184	NF CARBON R	R25J-10	1	415471004T
R5185	NF CARBON R	R25J-10	1	415471004T
R5186	NF CARBON R	R25J-10	1	415471004T
R5190	NF CARBON R	R25J-10	1	415471004T
R5191	NF CARBON R	R25J-10	1	415471004T
R5192	NF CARBON R	R25J-10	1	415471004T
R5193	NF CARBON R	R25J-10	1	415471004T

R5194	NF CARBON R	R25J-10	1	415471004T
R5195	NF CARBON R	R25J-10	1	415471004T
R5196	NF CARBON R	R25J-10	1	415471004T
R5200	NF CARBON R	R25J-18K	1	415471834T
R5201	NF CARBON R	R25J-18K	1	415471834T
R5202	NF CARBON R	R25J-18K	1	415471834T
R5203	NF CARBON R	R25J-33K	1	415473334T
R5204	NF CARBON R	R25J-33K	1	415473334T
R5205	NF CARBON R	R25J-33K	1	415473334T
R5206	NF CARBON R	R25J-33K	1	415473334T
R5210	NF CARBON R	R25J-820	1	415478214T
R5211	NF CARBON R	R25J-820	1	415478214T
R5212	NF CARBON R	R25J-820	1	415478214T
R5213	NF CARBON R	R25J-820	1	415478214T
R5214	NF CARBON R	R25J-820	1	415478214T
R5215	NF CARBON R	R25J-820	1	415478214T
R5216	NF CARBON R	R25J-820	1	415478214T
R5223	NF CARBON R	R25J-220	1	415472214T
R5224	NF CARBON R	R25J-220	1	415472214T
R5225	NF CARBON R	R25J-220	1	415472214T
R5226	NF CARBON R	R25J-220	1	415472214T
R5270	NF CARBON R	R25J-220	1	415472214T
R5271	NF CARBON R	R25J-220	1	415472214T
R5272	NF CARBON R	R25J-220	1	415472214T
R5273	NF CARBON R	R25J-220	1	415472214T
R5274	NF CARBON R	R25J-220	1	415472214T
R5275	NF CARBON R	R25J-220	1	415472214T
R5276	NF CARBON R	R25J-220	1	415472214T
R5280	NF CARBON R	R25J-220	1	415472214T
R5281	NF CARBON R	R25J-220	1	415472214T
R5282	NF CARBON R	R25J-220	1	415472214T
R5283	NF CARBON R	R25J-220	1	415472214T
R5284	NF CARBON R	R25J-220	1	415472214T
R5285	NF CARBON R	R25J-220	1	415472214T
R5286	NF CARBON R	R25J-220	1	415472214T
R5290	C-CARBON R	RN72K1J-103JE	1	435031034R1
R5291	C-CARBON R	RN72K1J-103JE	1	435031034R1
R5292	C-CARBON R	RN72K1J-103JE	1	435031034R1
R5293	C-CARBON R	RN72K1J-103JE	1	435031034R1
R5294	C-CARBON R	RN72K1J-103JE	1	435031034R1
R5295	C-CARBON R	RN72K1J-103JE	1	435031034R1
R5296	C-CARBON R	RN72K1J-103JE	1	435031034R1
R5300	C-CARBON R	RN72K1J-331JE	1	435033314R1
R5301	C-CARBON R	RN72K1J-331JE	1	435033314R1
R5302	C-CARBON R	RN72K1J-331JE	1	435033314R1
R5303	C-CARBON R	RN72K1J-331JE	1	435033314R1
R5304	C-CARBON R	RN72K1J-331JE	1	435033314R1
R5305	C-CARBON R	RN72K1J-331JE	1	435033314R1
R5306	C-CARBON R	RN72K1J-331JE	1	435033314R1
R5310	C-CARBON R	RN72K1J-331JE	1	435033314R1
R5311	C-CARBON R	RN72K1J-331JE	1	435033314R1
R5312	C-CARBON R	RN72K1J-331JE	1	435033314R1
R5313	C-CARBON R	RN72K1J-331JE	1	435033314R1
R5314	C-CARBON R	RN72K1J-331JE	1	435033314R1
R5315	C-CARBON R	RN72K1J-331JE	1	435033314R1
R5316	C-CARBON R	RN72K1J-331JE	1	435033314R1
R5350	NF CARBON R	R25J-33	1	415473304T
R5351	NF CARBON R	R25J-33	1	415473304T
R5352	NF CARBON R	R25J-33	1	415473304T
R5353	NF CARBON R	R25J-47	1	415474704T
R5354	NF CARBON R	R25J-47	1	415474704T
R5355	NF CARBON R	R25J-47	1	415474704T
R5356	NF CARBON R	R25J-47	1	415474704T
R5360	NF CARBON R	R25J-33	1	415473304T
R5361	NF CARBON R	R25J-33	1	415473304T
R5362	NF CARBON R	R25J-33	1	415473304T
R5363	NF CARBON R	R25J-47	1	415474704T
R5364	NF CARBON R	R25J-47	1	415474704T
R5365	NF CARBON R	R25J-47	1	415474704T
R5366	NF CARBON R	R25J-47	1	415474704T
R5370	NF CARBON R	R25J-2.2	1	415470224T
R5371	NF CARBON R	R25J-2.2	1	415470224T
R5372	NF CARBON R	R25J-2.2	1	415470224T
R5373	NF CARBON R	R25J-18	1	415471804T
R5374	NF CARBON R	R25J-18	1	415471804T
R5375	NF CARBON R	R25J-18	1	415471804T

R5376	NF CARBON R	R25J-18	1	415471804T
R5380	NF CARBON R	R25J-2.2	1	415470224T
R5381	NF CARBON R	R25J-2.2	1	415470224T
R5382	NF CARBON R	R25J-2.2	1	415470224T
R5383	NF CARBON R	R25J-18	1	415471804T
R5384	NF CARBON R	R25J-18	1	415471804T
R5385	NF CARBON R	R25J-18	1	415471804T
R5386	NF CARBON R	R25J-18	1	415471804T
R5390	C-CARBON R	RN72K1J-121JE	1	435031214R1
R5391	C-CARBON R	RN72K1J-121JE	1	435031214R1
R5392	C-CARBON R	RN72K1J-121JE	1	435031214R1
R5393	C-CARBON R	RN72K1J-121JE	1	435031214R1
R5394	C-CARBON R	RN72K1J-121JE	1	435031214R1
R5395	C-CARBON R	RN72K1J-121JE	1	435031214R1
R5396	C-CARBON R	RN72K1J-121JE	1	435031214R1
R5420	NF CARBON R	R25J-10	1	415471004T
R5421	NF CARBON R	R25J-10	1	415471004T
R5422	NF CARBON R	R25J-10	1	415471004T
R5423	NF CARBON R	R25J-10	1	415471004T
R5424	NF CARBON R	R25J-10	1	415471004T
R5425	NF CARBON R	R25J-10	1	415471004T
R5426	NF CARBON R	R25J-10	1	415471004T
R5440	TRIM R	N06HR1KBB	1	5211401T
R5441	TRIM R	N06HR1KBB	1	5211401T
R5442	TRIM R	N06HR1KBB	1	5211401T
R5443	TRIM R	N06HR1KBB	1	5211401T
R5444	TRIM R	N06HR1KBB	1	5211401T
R5445	TRIM R	N06HR1KBB	1	5211401T
R5446	TRIM R	N06HR1KBB	1	5211401T
R5450	C-CARBON R	RN72K1J-272JE	1	435032724R1
R5451	C-CARBON R	RN72K1J-272JE	1	435032724R1
R5452	C-CARBON R	RN72K1J-272JE	1	435032724R1
R5453	C-CARBON R	RN72K1J-272JE	1	435032724R1
R5454	C-CARBON R	RN72K1J-272JE	1	435032724R1
R5455	C-CARBON R	RN72K1J-272JE	1	435032724R1
R5456	C-CARBON R	RN72K1J-272JE	1	435032724R1
R5470	NF CARBON R	R25J-82	1	415478204T
R5471	NF CARBON R	R25J-82	1	415478204T
R5472	NF CARBON R	R25J-82	1	415478204T
R5473	NF CARBON R	R25J-82	1	415478204T
R5474	NF CARBON R	R25J-82	1	415478204T
R5475	NF CARBON R	R25J-82	1	415478204T
R5476	NF CARBON R	R25J-82	1	415478204T
R5480	C-CARBON R	RN72K2E-100JE	1	435221004R1
R5481	C-CARBON R	RN72K2E-100JE	1	435221004R1
R5482	C-CARBON R	RN72K2E-100JE	1	435221004R1
R5483	C-CARBON R	RN72K2E-100JE	1	435221004R1
R5484	C-CARBON R	RN72K2E-100JE	1	435221004R1
R5485	C-CARBON R	RN72K2E-100JE	1	435221004R1
R5486	C-CARBON R	RN72K2E-100JE	1	435221004R1
R5490	C-CARBON R	RN72K2E-100JE	1	435221004R1
R5491	C-CARBON R	RN72K2E-100JE	1	435221004R1
R5492	C-CARBON R	RN72K2E-100JE	1	435221004R1
R5493	C-CARBON R	RN72K2E-100JE	1	435221004R1
R5494	C-CARBON R	RN72K2E-100JE	1	435221004R1
R5495	C-CARBON R	RN72K2E-100JE	1	435221004R1
R5496	C-CARBON R	RN72K2E-100JE	1	435221004R1
[SW TRM]				
P6000A	SOCKET	NSCT-9P2189	1	25052292
P6001A	SOCKET	NSCT-9P2189	1	25052292
P6002A	SOCKET	NSCT-9P2189	1	25052292
P6003A	SOCKET	NSCT-9P2189	1	25052292
P6004A	SOCKET	NSCT-9P2189	1	25052292
P6005A	SOCKET	NSCT-9P2189	1	25052292
P6006A	SOCKET	NSCT-9P2189	1	25052292
P6007A	TRM	NTM-1P233(M1969)	1	25060302
P6008A	TRM	NTM-1P233(M1969)	1	25060302
P6009A	TRM	NTM-1P233(M1969)	1	25060302
P6010A	TRM	NTM-1P233(M1969)	1	25060302
P6012	TRM-423(SCREW)	NEJITANSI ST3	1	25060495

CIRCUIT NO	PART NAME	DESCRIPTION	Q'TY	PART NO. (SN)	REMARKS
[SEMI CONDUCTOR]					
D201	DIODE	G10XB80-02-54A-T	1	22380378	
D201 or	DIODE	D5SBA60	(1)	22380070	
D202	C-DIODE	DA2J10100	1	223303R2	
D202 or	C-DIODE	1SS352	(1)	223234R2	
D203	C-DIODE	DA2J10100	1	223303R2	
D203 or	C-DIODE	1SS352	(1)	223234R2	
D204	ZENER D	DZ2J062MOL	1	224760620R2	
D204 or	ZENER D	UDZS6.2B	(1)	224550620R2	
D205	DIODE	RB050M-30GTR	1	22380373R2	
D2101	C-DIODE	DA2J10100	1	223303R2	
D2101 or	C-DIODE	1SS352	(1)	223234R2	
D2102	C-DIODE	DA2J10100	1	223303R2	
D2102 or	C-DIODE	1SS352	(1)	223234R2	
D6600	C-DIODE	DA2J10100	1	223303R2	
D6600 or	C-DIODE	1SS352	(1)	223234R2	
D6602	C-DIODE	DA2J10100	1	223303R2	
D6602 or	C-DIODE	1SS352	(1)	223234R2	
D6604	C-DIODE	DA2J10100	1	223303R2	
D6604 or	C-DIODE	1SS352	(1)	223234R2	
D6608	C-DIODE	DA2J10100	1	223303R2	
D6608 or	C-DIODE	1SS352	(1)	223234R2	
Q2001	IC	NJW1328	1	22242691R3	
Q201	IC	S-1172B50-U5T1G	1	22242765R2	
Q6600	TR	KRC105S	1	2217290R2	
Q6600 or	TR	RN1405	(1)	2214500R2	
Q6601	TR	KRC105S	1	2217290R2	
Q6601 or	TR	RN1405	(1)	2214500R2	
Q6604	TR	KRC105S	1	2217290R2	
Q6604 or	TR	RN1405	(1)	2214500R2	
Q6608	TR	KRC105S	1	2217290R2	
Q6608 or	TR	RN1405	(1)	2214500R2	
[CHASSIS SCREW]					
D201C	SCREW	3P+10FN(3BC)	1	82143010GR	
[TRANS COIL]					
L201	CORE	BLM18PG181SN1D	1	2350005R1	
[CAPACITOR]					
C2000	C-CERA C	CK725F1E-104Z1	1	332161040R1	
C2001	C-CERA C	CK725F1E-104Z1	1	332161040R1	
C2004	C-CERA C	CK725F1E-104Z1	1	332161040R1	
C2005	C-CERA C	CK725F1A-105Z1	1	332181050R1	
C2006	C-CERA C	CK725F1A-105Z1	1	332181050R1	
C2007	C-CERA C	CK725F1A-105Z1	1	332181050R1	
C2008	C-CERA C	CK725F1E-104Z1	1	332161040R1	
C2009	C-CERA C	CK725F1A-105Z1	1	332181050R1	
C201	ELECT C	CE69W25V-10000M	1	3504502	
C201 or	ELECT C	CE69W25V-10000M	(1)	3504503	
C2010	C-CERA C	CK725F1A-105Z1	1	332181050R1	
C2011	C-CERA C	CK725F1E-104Z1	1	332161040R1	
C2012	C-CERA C	CK725F1E-104Z1	1	332161040R1	
C2013	C-CERA C	CK725F1E-104Z1	1	332161040R1	
C2014	C-CERA C	CK725F1E-104Z1	1	332161040R1	
C2015	C-CERA C	CK725F1E-104Z1	1	332161040R1	
C2016	C-CERA C	CK725F1A-105Z1	1	332181050R1	
C202	VR C	CE04W50V-4.7M(VR)	1	394680477T	
C202 or	JAMICON	CE04W50V-4.7M	(1)	398580477T	
C203	TF C	ECQ-V50V-334J	1	374723344T	
C204	C-CERA C	CK725B0J-226M	1	332092267R2	
C205	C-CERA C	CK725B0J-226M	1	332092267R2	
C207	VR C	CE04W6.3V-470M(VR)	1	394624717T	
C207 or	JAMICON	CE04W6.3V-470M	(1)	398524717T	
C208	C-CERA C	CK725F1E-104Z1	1	332161040R1	
C2101	VR C	CE04W50V-2.2M(VR)	1	394680227T	
C2101 or	JAMICON	CE04W50V-2.2M	(1)	398580227T	
C2102	VR C	CE04W50V-2.2M(VR)	1	394680227T	
C2102 or	JAMICON	CE04W50V-2.2M	(1)	398580227T	
C2103	VR C	CE04W50V-2.2M(VR)	1	394680227T	
C2103 or	JAMICON	CE04W50V-2.2M	(1)	398580227T	
C2105	VR C	CE04W50V-2.2M(VR)	1	394680227T	
C2105 or	JAMICON	CE04W50V-2.2M	(1)	398580227T	
C2106	VR C	CE04W6.3V-470M(VR)	1	394624717T	
C2106 or	JAMICON	CE04W6.3V-470M	(1)	398524717T	
C2107	VR C	CE04W6.3V-470M(VR)	1	394624717T	
C2107 or	JAMICON	CE04W6.3V-470M	(1)	398524717T	
C2108	VR C	CE04W6.3V-470M(VR)	1	394624717T	

C2108 or	JAMICON	CE04W6.3V-470M	(1)	398524717T	
C2109	VR C	CE04W6.3V-470M(VR)	1	394624717T	
C2109 or	JAMICON	CE04W6.3V-470M	(1)	398524717T	
C2110	VR C	CE04W50V-2.2M(VR)	1	394680227T	
C2110 or	JAMICON	CE04W50V-2.2M	(1)	398580227T	
C2111	VR C	CE04W50V-2.2M(VR)	1	394680227T	
C2111 or	JAMICON	CE04W50V-2.2M	(1)	398580227T	
C2112	VR C	CE04W50V-2.2M(VR)	1	394680227T	
C2112 or	JAMICON	CE04W50V-2.2M	(1)	398580227T	
C2113	C-CERA C	CK725B1H-102K1	1	332101025R1	
C2114	C-CERA C	CK725B1H-102K1	1	332101025R1	
C2116	C-CERA C	CK725B1H-103K1	1	332101035R1	
C2201	VR C	CE04W16V-100M(VR)	1	394641017T	
C2201 or	JAMICON	CE04W16V-100M	(1)	398541017T	
C2202	VR C	CE04W16V-100M(VR)	1	394641017T	
C2202 or	JAMICON	CE04W16V-100M	(1)	398541017T	
C2203	VR C	CE04W16V-100M(VR)	1	394641017T	
C2203 or	JAMICON	CE04W16V-100M	(1)	398541017T	
C2204	VR C	CE04W16V-100M(VR)	1	394641017T	
C2204 or	JAMICON	CE04W16V-100M	(1)	398541017T	
C2254	C-CERA C	CK725F1A-105Z1	1	332181050R1	
C2255	C-CERA C	CK725F1A-105Z1	1	332181050R1	
C2256	C-CERA C	CK725F1A-105Z1	1	332181050R1	
C6600	C-CERA C	CK725B1H-103K1	1	332101035R1	
C6601	C-CERA C	CK725B1H-103K1	1	332101035R1	
C6602	C-CERA C	CK725B1H-103K1	1	332101035R1	
C6604	C-CERA C	CK725B1H-103K1	1	332101035R1	
C6608	C-CERA C	CK725B1H-103K1	1	332101035R1	
C6639	TF C	ECQ-V50V-103J	1	374721034T	
C6640	TF C	ECQ-V50V-103J	1	374721034T	
C6641	TF C	ECQ-V50V-103J	1	374721034T	
C6642	TF C	ECQ-V50V-103J	1	374721034T	
C6643	TF C	ECQ-V50V-103J	1	374721034T	
C6644	TF C	ECQ-V50V-103J	1	374721034T	
C6645	TF C	ECQ-V50V-103J	1	374721034T	
C6648	TF C	ECQ-V50V-103J	1	374721034T	
C6649	TF C	ECQ-V50V-103J	1	374721034T	
C6650	MKT C	B32529C0102J289	1	376491024T	
C6651	MKT C	B32529C0102J289	1	376491024T	
C6652	MKT C	B32529C0102J289	1	376491024T	
C6653	MKT C	B32529C0102J289	1	376491024T	
C6654	MKT C	B32529C0102J289	1	376491024T	
C6655	MKT C	B32529C0102J289	1	376491024T	
C6658	MKT C	B32529C0102J289	1	376491024T	
C6659	MKT C	B32529C0102J289	1	376491024T	
C6660	MKT C	B32529C0102J289	1	376491024T	
[RESISTOR]					
F201	FUSE	T4A-SEUL-T250V	1	252392T	1
R2001	C-CARBON R	RN72K1J-563JE	1	435035634R1	
R2002	C-CARBON R	RN72K1J-563JE	1	435035634R1	
R2003	C-CARBON R	RN72K1J-183JE	1	435031834R1	
R2004	C-CARBON R	RN72K1J-103JE	1	435031034R1	
R2005	C-CARBON R	RN72K1J-183JE	1	435031834R1	
R2006	C-CARBON R	RN72K1J-103JE	1	435031034R1	
R2007	C-CARBON R	RN72K1J-222JE	1	435032224R1	
R2008	C-CARBON R	RN72K1J-222JE	1	435032224R1	
R201	C-CARBON R	RN72K1J-104JE	1	435031044R1	
R202	C-CARBON R	RN72K1J-103JE	1	435031034R1	
R2031	C-CARBON R	RN72K1J-000JE	1	435030004R1	
R2035	C-CARBON R	RN72K1J-000JE	1	435030004R1	
R2101	C-CARBON R	RN72K1J-750JE	1	435037504R1	
R2102	C-CARBON R	RN72K1J-750JE	1	435037504R1	
R2103	C-CARBON R	RN72K1J-750JE	1	435037504R1	
R2105	C-CARBON R	RN72K1J-750JE	1	435037504R1	
R2106	C-CARBON R	RN72K1J-750JE	1	435037504R1	
R2107	C-CARBON R	RN72K1J-750JE	1	435037504R1	
R2108	C-CARBON R	RN72K1J-750JE	1	435037504R1	
R2109	C-CARBON R	RN72K1J-750JE	1	435037504R1	
R2110	C-CARBON R	RN72K1J-750JE	1	435037504R1	
R2111	C-CARBON R	RN72K1J-750JE	1	435037504R1	
R2112	C-CARBON R	RN72K1J-750JE	1	435037504R1	
R2114	C-CARBON R	RN72K1J-104JE	1	435031044R1	
R2115	C-CARBON R	RN72K1J-104JE	1	435031044R1	
R2116	C-CARBON R	RN72K1J-104JE	1	435031044R1	
R2117	C-CARBON R	RN72K1J-104JE	1	435031044R1	
R2201	C-CARBON R	RN72K1J-000JE	1	435030004R1	

R2202	C-CARBON R	RN72K1J-561JE	1	435035614R1
R2203	C-CARBON R	RN72K1J-000JE	1	435030004R1
R2204	C-CARBON R	RN72K1J-000JE	1	435030004R1
R2205	C-CARBON R	RN72K1J-561JE	1	435035614R1
R2212	C-CARBON R	RN72K1J-000JE	1	435030004R1
R2213	C-CARBON R	RN72K1J-000JE	1	435030004R1
R6690	METAL O R	RS1/2WBJ-10	1	443521004T
R6691	METAL O R	RS1/2WBJ-390	1	443523914T
R6692	METAL O R	RS1/2WBJ-390	1	443523914T

[SW TRM]

P2201	PIN JACK	NPJ-3PDYYY560	1	25045778
P2202	PIN JACK	NPJ-2PDY748	1	25046003
P2203	PIN JACK	NPJ-6PDGLRGLR646	1	25045871
P2800A	SOCKET	NSCT-13P2404	1	25052507
P2801A	SOCKET	NSCT-9P2400	1	25052503
P603B	PLUG	NPLG-9P224	1	25055240
P605B	PLUG	NPLG-5P119	1	25055135
P6600B	PLUG	NPLG-7P222	1	25055238
P6601	TRM	NTM-2PDMCR400	1	25060472
P6602	TRM	NTM-4PDMNRR420	1	25060492
P6603	TRM	NTM-4PDMNRR420	1	25060492
P6604	TRM	NTM-4PDMNRR420	1	25060492
P6608	TRM	NTM-4PDMNRR420	1	25060492
P6613	RETAINER	(JOINT)	1	27142069
P8004A	SOCKET	NSCT-7P2398	1	25052501
P801	SOCKET AS	NSAS-3P2173	1	2009991362UL
P801A	WIRE HOL	NSCT-3P894	1	25051107
P952B	PLUG	NPLG-3P117	1	25055133
RL660	RELAY	NRL-2P5A-DC24-129	1	25065563A
RL660 or	RELAY	NRL-2P8A-DC24-144	(1)	25065590
RL660 or	RELAY	NRL-2P5A-DC24-193	(1)	25065703
RL660 or	RELAY	NRL-2P8A-DC24-201	(1)	25065718
RL661	RELAY	NRL-2P5A-DC24-129	1	25065563A
RL661 or	RELAY	NRL-2P8A-DC24-144	(1)	25065590
RL661 or	RELAY	NRL-2P5A-DC24-193	(1)	25065703
RL661 or	RELAY	NRL-2P8A-DC24-201	(1)	25065718
RL662	RELAY	NRL-2P5A-DC24-129	1	25065563A
RL662 or	RELAY	NRL-2P8A-DC24-144	(1)	25065590
RL662 or	RELAY	NRL-2P5A-DC24-193	(1)	25065703
RL662 or	RELAY	NRL-2P8A-DC24-201	(1)	25065718
RL664	RELAY	NRL-2P5A-DC24-129	1	25065563A
RL664 or	RELAY	NRL-2P8A-DC24-144	(1)	25065590
RL664 or	RELAY	NRL-2P5A-DC24-193	(1)	25065703
RL664 or	RELAY	NRL-2P8A-DC24-201	(1)	25065718
RL668	RELAY	NRL-2P5A-DC24-129	1	25065563A
RL668 or	RELAY	NRL-2P8A-DC24-144	(1)	25065590
RL668 or	RELAY	NRL-2P5A-DC24-193	(1)	25065703
RL668 or	RELAY	NRL-2P8A-DC24-201	(1)	25065718

[MECHA PARTS]

D201B	HEAT SINK	RAD-083	1	27160271
-------	-----------	---------	---	----------

U005 BAETC-1348-1B : NSP

CIRCUIT NO.	PART NAME	DESCRIPTION	Q'TY	PART NO. (SN)	REMARKS
-------------	-----------	-------------	------	---------------	---------

[SEMI CONDUCTOR]

Q792	IC	S-16A1A33-U5T1U3	1	22242844R2	
------	----	------------------	---	------------	--

[CAPACITOR]

C790	C-CERA C	CK732B16V-106K	1	332071065R2	
C794	C-CERA C	CK725B1H-103K0	1	332031035R1	
C795	C-CERA C	CK725B1H-103K0	1	332031035R1	
C796	C-CERA C	CK725B1H-103K0	1	332031035R1	
C799	C-CERA C	CK732B16V-106K	1	332071065R2	

[SW TRM]

P3102C	PLUG	NPLG-5P918	1	25055965R2	
P791B	SOCKET	DF40HC(2.5)-30DS-0.4V(70)	1	25053514R2	

U006 BADIS-1330-1E : NSP

CIRCUIT NO.	PART NAME	DESCRIPTION	Q'TY	PART NO. (SN)	REMARKS
-------------	-----------	-------------	------	---------------	---------

[SEMI CONDUCTOR]

D1000	C-DIODE	DA2J10100	1	223303R2	
D1000 or	C-DIODE	1SS352	(1)	223234R2	
D1001	C-DIODE	DA2J10100	1	223303R2	
D1001 or	C-DIODE	1SS352	(1)	223234R2	
D1011	PHT CP	JSR1165-001recieving	1	24120143	
D7502	ZENER D	DZ2J082MOL	1	224760820R2	
D7502 or	ZENER D	UDZS8.2B	(1)	224550820R2	
D7533	ZENER D	DZ2J039MOL	1	224760390R2	
D7533 or	ZENER D	UDZS3.9B	(1)	224550390R2	
D7652	LED	SLI-343Y8C-3F	1	225491	
D7653	LED	LW340A	1	225517	
D7654	LED	SCB3318E-D2	1	225487	
D7656	LED	LW340A	1	225517	
D7656A	HOLDER	(LED)LH-5-5	1	27191312	
D7659	LED	LW340A	1	225517	
D7659A	HOLDER	(LED)LH-5-5	1	27191312	
D7801	ZENER D	DZ2J051MOL	1	224760510R2	
D7801 or	ZENER D	UDZS5.1B	(1)	224550510R2	
D7811	ZENER D	DZ2J068MOL	1	224760680R2	
D7811 or	ZENER D	UDZS6.8B	(1)	224550680R2	
D7812	ZENER D	DZ2J068MOL	1	224760680R2	
D7812 or	ZENER D	UDZS6.8B	(1)	224550680R2	
D7901	C-DIODE	DA2J10100	1	223303R2	
D7901 or	C-DIODE	1SS352	(1)	223234R2	
D7902	C-DIODE	DA2J10100	1	223303R2	
D7902 or	C-DIODE	1SS352	(1)	223234R2	
D7903	C-DIODE	DA2J10100	1	223303R2	
D7903 or	C-DIODE	1SS352	(1)	223234R2	
D7904	C-DIODE	DA2J10100	1	223303R2	
D7904 or	C-DIODE	1SS352	(1)	223234R2	
D9001	DIODE	S1WB(A)60B-7062	1	22380377R2	
D9002	SPCF D	P6SMB200A-M3/52T	1	225505R2	
D9003	DIODE	US1K-E3/61T	1	22380376R2	
D9004	DIODE	RF301B2STL	1	22380374R2	
D9006	DIODE	M1FL20U	1	223276R2	
D9008	DIODE	RB050M-30GTR	1	22380373R2	
D9011	C-DIODE	DA2J10100	1	223303R2	
D9011 or	C-DIODE	1SS352	(1)	223234R2	
D9012	ZENER D	DZ2J360MOL	1	224763600R2	
D9012 or	ZENER D	UDZS36B	(1)	224553600R2	
D9013	SPCF D	P6SMB20A-M3/52	1	225515R2	
D9018	ZENER D	DZ2J200MOL	1	224762000R2	N
D9018 or	ZENER D	UDZS20B	(1)	224552000R2	
D960	DIODE	RL1N4003	1	22380260T	
D961	DIODE	RL1N4003	1	22380260T	
D962	ZENER D	DZ2J360MOL	1	224763600R2	
D962 or	ZENER D	UDZS36B	(1)	224553600R2	
Q1000	IC	TC74HCU04AF	1	222740046R2TO	
Q1501	IC	NJM4580M-D	1	22241448R2	
Q1502	IC	NJM4580M-D	1	22241448R2	
Q1503	IC	NJM4580M-D	1	22241448R2	
Q1504	IC	NJM4580M-D	1	22241448R2	
Q1581	IC	NJM4580M-D	1	22241448R2	
Q7501	IC	ML9208A-13GA	1	22242772R3	
Q7502	FL TUBE	16-BT-168GNK	1	212279	
Q7502A	HOLDER	(FL)	1	27191222C	
Q7503	TR	KTC3875-GR	1	2216175R2	
Q7504	TR	KTC3875-GR	1	2216175R2	
Q7505	TR	KRA102S	1	2216220R2	
Q7507	TR	KRC102S	1	2216190R2	
Q7508	TR	2SC2712-GR	1	2213145R2	
Q7508 or	TR	KTC3875-GR	(1)	2216175R2	
Q7509	TR	KRA107S	1	2216350R2	
Q7510	TR	KRC107S	1	2216340R2	
Q7533	TR	KTC3875-GR	1	2216175R2	
Q7541	REMO SENS	IRM-3638M3S28	1	24130026	
Q7653	TR	DTC123JKA	1	2216690R2	
Q7653 or	TR	KRC105S	(1)	2217290R2	
Q7654	TR	DTC123JKA	1	2216690R2	
Q7654 or	TR	KRC105S	(1)	2217290R2	
Q7656	TR	DTC123JKA	1	2216690R2	
Q7656 or	TR	KRC105S	(1)	2217290R2	
Q7657	TR	DTC123JKA	1	2216690R2	
Q7657 or	TR	KRC105S	(1)	2217290R2	
Q7702A	RETAINER	(GND)	1	27142222A	
Q7802	IC	NJM4580M-D	1	22241448R2	

Q7803	TR	DTC114TKA	1	2216670R2	
Q7803 or	TR	KRC111S	(1)	2217850R2	
Q7804	TR	DTC114TKA	1	2216670R2	
Q7804 or	TR	KRC111S	(1)	2217850R2	
Q9001	IC	STR-A6051M	1	222154	
Q9002	IC	EL816MX	1	22242845	N
Q9002 or	IC	PC123X8YFZ0F	(1)	22242771	
Q9002 or	IC	PS2561DL1-1Y-A(Q)	(1)	22242794	
Q9003	IC	EL816MX	1	22242845	N
Q9003 or	IC	PC123X8YFZ0F	(1)	22242771	
Q9003 or	IC	PS2561DL1-1Y-A(Q)	(1)	22242794	
Q9004	IC	KIA431A-AT/P	1	22242770T	
Q9005	TR	KRC102S	1	2216190R2	
Q9005 or	TR	RN1402	(1)	2214470R2	
Q960	TR	2SC2881-Y(Te12L,CF)	1	2217564R2	
[TRANS COIL]					
L1000	CHOKE COIL	LBC2518T2R2M	1	231364M022R2	
L1001	CHOKE COIL	LBC2518T2R2M	1	231364M022R2	
L1002	CHOKE COIL	LBC2518T2R2M	1	231364M022R2	
L1003	CHOKE COIL	LBC2518T470M	1	231364M470R2	
L1004	CHOKE COIL	LBC2518T470M	1	231364M470R2	
L1005	EMIFIL	BK1608HS102-T	1	230955R2	
L1006	EMIFIL	BK1608HS102-T	1	230955R2	
L7531	CHOKE COIL	LBC2518T2R2M	1	231364M022R2	
L7532	CHOKE COIL	LBC2518T2R2M	1	231364M022R2	
L7751	CHOKE COIL	LBC2518T2R2M	1	231364M022R2	
L7752	CHOKE COIL	LBC2518T2R2M	1	231364M022R2	
L7753	CHOKE COIL	LBC2518T2R2M	1	231364M022R2	
L7831	CHOKE COIL	LBC2518T2R2M	1	231364M022R2	
L7832	CHOKE COIL	LBC2518T2R2M	1	231364M022R2	
L7901	EMIFIL	BK1608LM182-T	1	230958R1	
L7902	CORE	BLM18PG121SN1D	1	2350006R1	
L7903	CORE	BLM18PG121SN1D	1	2350006R1	
L9001	CHOKE COIL	ELF15N004A	1	231453	
L9002	CHOKE COIL	ROR1010NP-100M	1	231449M100	
L9004	CORE	BLM18PG181SN1D	1	2350005R1	
L9005	CORE	BLM18PG181SN1D	1	2350005R1	
T9001	P TRANS	NPT-1633S	1	2302077	!
T9001 or	P TRANS	NPT-1632S	(1)	2302076	!
[CAPACITOR]					
C1000	C-CERA C	CK725F1E-104Z1	1	332161040R1	
C1001	C-CERA C	CC725CH1H-101J1	1	342101014R1	
C1002	C-CERA C	CC725CH1H-101J1	1	342101014R1	
C1003	C-CERA C	CK725B1C-104K1	1	332121045R1	
C1004	C-CERA C	CK725B1C-104K1	1	332121045R1	
C1005	C-CERA C	CC725CH1H-080D1	1	342100802R1	
C1006	C-CERA C	CC725CH1H-080D1	1	342100802R1	
C1007	UTSP C	CE04W25V-220M(UTSP)	1	397552217T	
C1008	C-CERA C	CK725F1E-104Z1	1	332161040R1	
C1009	C-CERA C	CK725F1E-104Z1	1	332161040R1	
C1011	C-CERA C	CC725CH1H-330J1	1	342103304R1	
C1013	UTSP C	CE04W25V-220M(UTSP)	1	397552217T	
C1500	UPZ C	2AUPZTF471JE	1	376334714T	
C1501	UPZ C	2AUPZTF471JE	1	376334714T	
C1502	UPZ C	2AUPZTF471JE	1	376334714T	
C1503	UPZ C	2AUPZTF471JE	1	376334714T	
C1504	UPZ C	2AUPZTF471JE	1	376334714T	
C1505	UPZ C	2AUPZTF471JE	1	376334714T	
C1506	UPZ C	2AUPZTF471JE	1	376334714T	
C1507	UPZ C	2AUPZTF471JE	1	376334714T	
C1510	UPZ C	2AUPZTF101JE	1	376331014T	
C1511	UPZ C	2AUPZTF101JE	1	376331014T	
C1512	UPZ C	2AUPZTF101JE	1	376331014T	
C1513	C-CERA C	CC725CH1H-101J1	1	342101014R1	
C1514	C-CERA C	CC725CH1H-101J1	1	342101014R1	
C1515	C-CERA C	CC725CH1H-101J1	1	342101014R1	
C1516	C-CERA C	CC725CH1H-101J1	1	342101014R1	
C1517	UPZ C	2AUPZTF101JE	1	376331014T	
C1520	UPZ C	2AUPZTF101JE	1	376331014T	
C1521	UPZ C	2AUPZTF101JE	1	376331014T	
C1522	UPZ C	2AUPZTF101JE	1	376331014T	
C1523	C-CERA C	CC725CH1H-101J1	1	342101014R1	
C1524	C-CERA C	CC725CH1H-101J1	1	342101014R1	
C1525	C-CERA C	CC725CH1H-101J1	1	342101014R1	
C1526	C-CERA C	CC725CH1H-101J1	1	342101014R1	
C1527	UPZ C	2AUPZTF101JE	1	376331014T	

C1580	UTSP C	CE04W50V-10M(UTSP)	1	397581007AT	
C1581	UTSP C	CE04W50V-10M(UTSP)	1	397581007AT	
C1582	C-CERA C	CC725CH1H-102J1	1	342101024R1	
C1583	C-CERA C	CC725CH1H-102J1	1	342101024R1	
C1584	C-CERA C	CC725CH1H-151J1	1	342101514R1	
C1585	C-CERA C	CC725CH1H-151J1	1	342101514R1	
C1597	C-CERA C	CK725B1C-104K1	1	332121045R1	
C1598	UTSP C	CE04W25V-220M(UTSP)	1	397552217T	
C1599	UTSP C	CE04W25V-220M(UTSP)	1	397552217T	
C7502	C-CERA C	CK725F1E-104Z1	1	332161040R1	
C7503	C-CERA C	CC725CH1H-101J1	1	342101014R1	
C7504	C-CERA C	CC725CH1H-101J1	1	342101014R1	
C7505	C-CERA C	CC725CH1H-101J1	1	342101014R1	
C7508	ELECT C	CE04W6.3V-100M(S)	1	353721019T	
C7509	C-CERA C	CK725F1E-104Z1	1	332161040R1	
C7510	C-CERA C	CK725B1H-223K1	1	332102235R1	
C7511	C-CERA C	CK725B1H-223K1	1	332102235R1	
C7512	C-CERA C	CK725B1H-223K1	1	332102235R1	
C7514	C-CERA C	CK725B1H-223K1	1	332102235R1	
C7515	ELECT C	CE04W16V-47M(S)	1	353744709T	
C7516	C-CERA C	CK725B1H-223K1	1	332102235R1	
C7517	C-CERA C	CK725B1H-223K1	1	332102235R1	
C7520	C-CERA C	CK725B1H-223K1	1	332102235R1	
C7521	C-CERA C	CK725B1H-103K1	1	332101035R1	
C7522	C-CERA C	CK725B1H-103K1	1	332101035R1	
C7523	C-CERA C	CC725CH1H-390J1	1	342103904R1	
C7531	C-CERA C	CK725B1H-223K1	1	332102235R1	
C7532	C-CERA C	CK725B1H-223K1	1	332102235R1	
C7533	ELECT C	CE04W16V-10M(S)	1	353741009T	
C7541	ELECT C	CE04W16V-10M(S)	1	353741009T	
C7542	C-CERA C	CC725CH1H-102J1	1	342101024R1	
C7543	C-CERA C	CC725CH1H-102J1	1	342101024R1	
C7550	C-CERA C	CK725F1E-104Z1	1	332161040R1	
C7705	C-CERA C	CK725F1E-104Z1	1	332161040R1	
C7716	C-CERA C	CK725F1E-104Z1	1	332161040R1	
C7751	C-CERA C	CC725CH1H-102J1	1	342101024R1	
C7752	C-CERA C	CK725B1H-223K1	1	332102235R1	
C7753	MKT C	B32529C0102J289	1	376491024T	
C7754	MKT C	B32529C0102J289	1	376491024T	
C7803	ELECT C	CE04W16V-47M(S)	1	353744709T	
C7805	ELECT C	CE04W16V-10M(S)	1	353741009T	
C7811	ELECT C	CE04W16V-47M(S)	1	353744709T	
C7812	ELECT C	CE04W16V-47M(S)	1	353744709T	
C7831	ELECT C	CE04W16V-10M(S)	1	353741009T	
C7832	C-CERA C	CC725CH1H-101J1	1	342101014R1	
C7833	C-CERA C	CC725CH1H-102J1	1	342101024R1	
C7834	C-CERA C	CC725CH1H-330J1	1	342103304R1	
C7901	C-CERA C	CK725F1E-104Z1	1	332161040R1	
C7903	C-CERA C	CK725F1E-104Z1	1	332161040R1	
C9001	IS C	LE104-MX-C3.5	1	3800049S	!
C9002	ELECT C	CE04W200V-100M(KXJ)	1	3500233S	
C9003	PW C	CE04W50V-10M(PW)	1	393781007T	
C9004	PW C	CE04W25V-1000M(PW)	1	393751027S	
C9006	PW C	CE04W25V-470M(PW)	1	393754717T	
C9009	C-CERA C	GRM31A7U3D220JW31D	1	3300071R1	
C9010	IS C	DE1E3KX102MB4BL01	1	3300066S	!
C9011	C-CERA C	CK725B1C-104K1	1	332121045R1	
C9012	IS C	ECQU2A103MLC	1	3800039S	!
C9012 or	IS C	LE103-C3.5	(1)	3800042S	!
C9013	UTSP C	CE04W25V-220M(UTSP)	1	397552217T	
C9014	C-CERA C	CC725CH1H-102J1	1	342101024R1	
C9015	C-CERA C	CK725F1E-104Z1	1	332161040R1	
C9016	C-CERA C	CK725B1H-332K1	1	332103325R1	
C9018	IS C	LE104-MX-C3.5	1	3800049S	!
C9019	IS C	DE1E3KX102MB4BL01	1	3300066S	!
C9020	IS C	DE1E3KX102MB4BL01	1	3300066S	!
C9023	C-CERA C	CK725F1E-104Z1	1	332161040R1	
C9024	C-CERA C	CK725F1E-104Z1	1	332161040R1	
C950	TF C	ECQ-V50V-104J	1	374721044T	
C960	VR C	CE04W63V-100M(VR)	1	394671017T	
C961	UTSP C	CE04W50V 47M(UTSP)	1	397584707AT	
C962	TF C	ECQ-V50V-104J	1	374721044T	
C963	UTSP C	CE04W50V 47M(UTSP)	1	397584707AT	
[RESISTOR]					
R1000	C-CARBON R	RN72K1J-331JE	1	435033314R1	
R1001	C-CARBON R	RN72K1J-750JE	1	435037504R1	

R1604	C-CARBON R	RN72K1J-000JE	1	435030004R1
R1625	C-CARBON R	RN72K1J-000JE	1	435030004R1
R1626	C-CARBON R	RN72K1J-000JE	1	435030004R1
R1627	C-CARBON R	RN72K1J-000JE	1	435030004R1
R1628	C-CARBON R	RN72K1J-000JE	1	435030004R1
R1629	C-CARBON R	RN72K1J-000JE	1	435030004R1
R1630	C-CARBON R	RN72K1J-000JE	1	435030004R1
R1631	C-CARBON R	RN72K1J-000JE	1	435030004R1
R7502	C-CARBON R	RN72K1J-332JE	1	435033324R1
R7503	C-CARBON R	RN72K1J-332JE	1	435033324R1
R7504	C-CARBON R	RN72K1J-221JE	1	435032214R1
R7505	C-CARBON R	RN72K1J-221JE	1	435032214R1
R7507	C-CARBON R	RN72K1J-221JE	1	435032214R1
R7508	C-CARBON R	RN72K1J-221JE	1	435032214R1
R7512	C-CARBON R	RN72K1J-103JE	1	435031034R1
R7513	C-CARBON R	RN72K1J-332JE	1	435033324R1
R7514	C-CARBON R	RN72K1J-473JE	1	435034734R1
R7515	C-CARBON R	RN72K1J-103JE	1	435031034R1
R7516	C-CARBON R	RN72K1J-103JE	1	435031034R1
R7517	C-CARBON R	RN72K1J-103JE	1	435031034R1
R7518	C-CARBON R	RN72K1J-333JE	1	435033334R1
R7519	C-CARBON R	RN72K1J-152JE	1	435031524R1
R7521	C-CARBON R	RN72K1J-103JE	1	435031034R1
R7522	C-CARBON R	RN72K1J-103JE	1	435031034R1
R7523	C-CARBON R	RN72K1J-103JE	1	435031034R1
R7524	C-CARBON R	RN72K1J-103JE	1	435031034R1
R7533	C-CARBON R	RN72K1J-221JE	1	435032214R1
R7541	C-CARBON R	RN72K1J-101JE	1	435031014R1
R7542	C-CARBON R	RN72K1J-102JE	1	435031024R1
R7601	C-CARBON R	RN72K1J-271JE	1	435032714R1
R7602	C-CARBON R	RN72K1J-331JE	1	435033314R1
R7603	C-CARBON R	RN72K1J-471JE	1	435034714R1
R7604	C-CARBON R	RN72K1J-561JE	1	435035614R1
R7605	C-CARBON R	RN72K1J-821JE	1	435038214R1
R7606	C-CARBON R	RN72K1J-122JE	1	435031224R1
R7607	C-CARBON R	RN72K1J-222JE	1	435032224R1
R7608	C-CARBON R	RN72K1J-392JE	1	435033924R1
R7609	C-CARBON R	RN72K1J-123JE	1	435031234R1
R7611	C-CARBON R	RN72K1J-271JE	1	435032714R1
R7612	C-CARBON R	RN72K1J-331JE	1	435033314R1
R7613	C-CARBON R	RN72K1J-471JE	1	435034714R1
R7614	C-CARBON R	RN72K1J-561JE	1	435035614R1
R7615	C-CARBON R	RN72K1J-821JE	1	435038214R1
R7616	C-CARBON R	RN72K1J-122JE	1	435031224R1
R7617	C-CARBON R	RN72K1J-222JE	1	435032224R1
R7618	C-CARBON R	RN72K1J-392JE	1	435033924R1
R7619	C-CARBON R	RN72K1J-123JE	1	435031234R1
R7621	C-CARBON R	RN72K1J-271JE	1	435032714R1
R7622	C-CARBON R	RN72K1J-331JE	1	435033314R1
R7623	C-CARBON R	RN72K1J-471JE	1	435034714R1
R7624	C-CARBON R	RN72K1J-561JE	1	435035614R1
R7625	C-CARBON R	RN72K1J-821JE	1	435038214R1
R7626	C-CARBON R	RN72K1J-122JE	1	435031224R1
R7627	C-CARBON R	RN72K1J-222JE	1	435032224R1
R7628	C-CARBON R	RN72K1J-392JE	1	435033924R1
R7629	C-CARBON R	RN72K1J-123JE	1	435031234R1
R7631	C-CARBON R	RN72K1J-271JE	1	435032714R1
R7632	C-CARBON R	RN72K1J-331JE	1	435033314R1
R7633	C-CARBON R	RN72K1J-471JE	1	435034714R1
R7634	C-CARBON R	RN72K1J-561JE	1	435035614R1
R7635	C-CARBON R	RN72K1J-821JE	1	435038214R1
R7636	C-CARBON R	RN72K1J-122JE	1	435031224R1
R7637	C-CARBON R	RN72K1J-222JE	1	435032224R1
R7638	C-CARBON R	RN72K1J-392JE	1	435033924R1
R7652	C-CARBON R	RN72K1J-222JE	1	435032224R1
R7653	C-CARBON R	RN72K1J-221JE	1	435032214R1
R7654	C-CARBON R	RN72K1J-182JE	1	435031824R1
R7656	C-CARBON R	RN72K1J-181JE	1	435031814R1
R7659	C-CARBON R	RN72K1J-181JE	1	435031814R1
R7801	C-CARBON R	RN72K1J-101JE	1	435031014R1
R7803	C-CARBON R	RN72K1J-472JE	1	435034724R1
R7806	C-CARBON R	RN72K1J-331JE	1	435033314R1
R7809	C-CARBON R	RN72K1J-221JE	1	435032214R1
R7810	C-CARBON R	RN72K1J-221JE	1	435032214R1
R7811	C-CARBON R	RN72K1J-271JE	1	435032714R1
R7812	C-CARBON R	RN72K1J-271JE	1	435032714R1

R7813	C-CARBON R	RN72K1J-224JE	1	435032244R1	
R7814	C-CARBON R	RN72K1J-104JE	1	435031044R1	
R7815	C-CARBON R	RN72K1J-221JE	1	435032214R1	
R7816	C-CARBON R	RN72K1J-221JE	1	435032214R1	
R7820	C-CARBON R	RN72K1J-473JE	1	435034734R1	
R7831	C-CARBON R	RN72K1J-221JE	1	435032214R1	
R7832	C-CARBON R	RN72K1J-224JE	1	435032244R1	
R7833	C-CARBON R	RN72K1J-473JE	1	435034734R1	
R7834	C-CARBON R	RN72K1J-102JE	1	435031024R1	
R7835	C-CARBON R	RN72K1J-333JE	1	435033334R1	
R9002	C-CARBON R	RN72K1J-000JE	1	435030004R1	
R9003	C-CARBON R	RN72K1J-332JE	1	435033324R1	
R9006	C-CARBON R	RN72K1J-392JE	1	435033924R1	
R9007	C-CARBON R	RN72K1J-273FE	1	435032732R1	
R9008	C-CARBON R	RN72K1J-822JE	1	435038224R1	
R9009	C-CARBON R	RN72K1J-103JE	1	435031034R1	
R9010	METAL O R	RS1/2WBJ-68	1	443526804T	
R9011	NF CARBON R	R25J-22	1	415472204T	
R9012	C-CARBON R	RN72K1J-271JE	1	435032714R1	
R9013	C-CARBON R	RN72K1J-000JE	1	435030004R1	
R9014	METAL R	RNU1WCJ-1	1	453630104T	
R9015	METAL O R	RS1/2WBJ-150	1	443521514T	
R9017	C-CARBON R	RN72K1J-332JE	1	435033324R1	
R9018	C-CARBON R	RN72K1J-182JE	1	435031824R1	
R9022	C-CARBON R	RN72K1J-152JE	1	435031524R1	
R9023	C-CARBON R	KTR18EZPF6803	1	435236842R1	
R9024	C-CARBON R	KTR18EZPF6803	1	435236842R1	
R9025	C-CARBON R	KTR18EZPF6803	1	435236842R1	
R950	C-CARBON R	RN72K1J-015JE	1	435030154R1	
R951	METAL O R	RS1WBJ-33	1	443623304T	
R952	METAL O R	RS1WBJ-33	1	443623304T	
R960	METAL R	RNU1/2WCJ-8.2	1	453530824T	
R962	C-CARBON R	RN72K1J-222JE	1	435032224R1	
R963	C-CARBON R	RN72K1J-332JE	1	435033324R1	
R964	C-CARBON R	RN72K1J-333JE	1	435033334R1	
R965	C-CARBON R	RN72K1J-047JE	1	435030474R1	
[SW TRM]					
F9001	FUSE	T1A-SEUL-T250V	1	252397T	!
F9002C	FUSE HOL	NSCT-1P2031	1	25052133T	!
F9002D	FUSE HOL	NSCT-1P2031	1	25052133T	!
P1000	ST JACK	MSJ-035-22	1	25045887	
P1001	PIN JACK	NPJ-2PDOO626	1	25045847	
P3101B	PLUG	NPLG-5P352	1	25055369	
P5502A	SOCKET	NSCT-20P2200	1	25052303	
P5503A	SOCKET	NSCT-15P2195	1	25052298	
P5504A	SOCKET	NSCT-5P2185	1	25052288	
P5511A	TRM	NTM-1P233(M1969)	1	25060302	
P605	SOCKET AS	NSAS-5P2194	1	2009991383UL	
P605A	WIRE HOL	NSCT-5P896	1	25051109	
P701B	SOCKET	NSCT-23P2441	1	25052544	
P702	SOCKET AS	NSAS-11P2160	1	2009991349UL	
P702A	WIRE HOL	NSCT-11P882	1	25051095	
P702B	PLUG	NPLG-11P358	1	25055375	
P703A	SOCKET	NSCT-9P2427	1	25052530	
P703B	SOCKET	NSCT-9P2400	1	25052503	
P7751	ST JACK	MSJ-064-05A SR	1	25045783	
P7752	TRM-423(SCREW)	NEJITANSI ST3	1	25060495	
P7802	ST JACK	MSJ-035-105C-B-RF-SR-PC(ONA)	1	25045990	
P7901	SOCKET	000010211-00027	1	25053411	
P8001A	PLUG	IMSA-9111B-24	1	25056625	
P8002A	PLUG	IMSA-9111B-16	1	25056620	
P8003A	PLUG	IMSA-9111B-16	1	25056620	
P9001A	PLUG	NPLG-2P631	1	25055675	
P9002	PLUG	NPLG-2P632	1	25055676	
P9003	TRM-423(SCREW)	NEJITANSI ST3	1	25060495	
P9004	RETAINER	(TRM-PS)	1	27142287	
P901	SOCKET AS	NSAS-5P2113	1	2009991302UL	
P901A	WIRE HOL	NSCT-5P876	1	25051089	
P951A	WIRE HOL	NSCT-5P876	1	25051089	
P951B	WIRE HOL	NSCT-5P876	1	25051089	
P955B	PLUG	NPLG-5P119	1	25055135	
RL9001	RELAY	NRL-1P10A-DC9-188	1	25065693	!
S7502	R ENCODE	EC12E2425WITH WASHER	1	25065655W	
S7600	PUSH SW	NPS-111-S681	1	25035718T	
S7601	PUSH SW	NPS-111-S681	1	25035718T	
S7602	PUSH SW	NPS-111-S681	1	25035718T	

S7605	PUSH SW	NPS-111-S681	1	25035718T
S7606	PUSH SW	NPS-111-S681	1	25035718T
S7607	PUSH SW	NPS-111-S681	1	25035718T
S7608	PUSH SW	NPS-111-S681	1	25035718T
S7609	PUSH SW	NPS-111-S681	1	25035718T
S7610	PUSH SW	NPS-111-S681	1	25035718T
S7611	PUSH SW	NPS-111-S681	1	25035718T
S7612	PUSH SW	NPS-111-S681	1	25035718T
S7613	PUSH SW	NPS-111-S681	1	25035718T
S7614	PUSH SW	NPS-111-S681	1	25035718T
S7615	PUSH SW	NPS-111-S681	1	25035718T
S7616	PUSH SW	NPS-111-S681	1	25035718T
S7617	PUSH SW	NPS-111-S681	1	25035718T
S7618	PUSH SW	NPS-111-S681	1	25035718T
S7619	PUSH SW	NPS-111-S681	1	25035718T
S7620	PUSH SW	NPS-111-S681	1	25035718T
S7621	PUSH SW	NPS-111-S681	1	25035718T
S7622	PUSH SW	NPS-111-S681	1	25035718T
S7623	PUSH SW	NPS-111-S681	1	25035718T
S7624	PUSH SW	NPS-111-S681	1	25035718T
S7625	PUSH SW	NPS-111-S681	1	25035718T
S7626	PUSH SW	NPS-111-S681	1	25035718T
S7627	PUSH SW	NPS-111-S681	1	25035718T
S7628	PUSH SW	NPS-111-S681	1	25035718T
S7629	PUSH SW	NPS-111-S681	1	25035718T
S7630	PUSH SW	NPS-111-S681	1	25035718T
S7631	PUSH SW	NPS-111-S681	1	25035718T
S7632	PUSH SW	NPS-111-S681	1	25035718T
S7636	PUSH SW	NPS-111-S681	1	25035718T
S7637	PUSH SW	NPS-111-S681	1	25035718T
S7638	PUSH SW	NPS-111-S681	1	25035718T

U008

BAHDM-1357-1B

: NSP

CIRCUIT NO.	PART NAME	DESCRIPTION	Q'TY	PART NO. (SN)	REMARKS
	[SEMI CONDUCTOR]				
D3101	C-DIODE	DA2J10100	1	223303R2	
D3101 or	C-DIODE	1SS352	(1)	223234R2	
D7001	C-DIODE	DA2J10100	1	223303R2	
D7001 or	C-DIODE	1SS352	(1)	223234R2	
D7002	C-DIODE	DA2J10100	1	223303R2	
D7002 or	C-DIODE	1SS352	(1)	223234R2	
D7003	C-DIODE	DA2J10100	1	223303R2	
D7003 or	C-DIODE	1SS352	(1)	223234R2	
D7004	C-DIODE	DA2J10100	1	223303R2	
D7004 or	C-DIODE	1SS352	(1)	223234R2	
D7005	C-DIODE	DA2J10100	1	223303R2	
D7005 or	C-DIODE	1SS352	(1)	223234R2	
D7006	C-DIODE	DA2J10100	1	223303R2	
D7006 or	C-DIODE	1SS352	(1)	223234R2	
D7007	ZENER D	DZ2J062M0L	1	224760620R2	
D7007 or	ZENER D	UDZS6.2B	(1)	224550620R2	
D7009	C-DIODE	DA2J10100	1	223303R2	
D7009 or	C-DIODE	1SS352	(1)	223234R2	
D7010	C-DIODE	DA2J10100	1	223303R2	
D7010 or	C-DIODE	1SS352	(1)	223234R2	
D7011	C-DIODE	DA2J10100	1	223303R2	
D7011 or	C-DIODE	1SS352	(1)	223234R2	
D7012	DIODE	RB050M-30GTR	1	22380373R2	
D7013	DIODE	RB050M-30GTR	1	22380373R2	
D8001	C-DIODE	DA2J10100	1	223303R2	
D8001 or	C-DIODE	1SS352	(1)	223234R2	
D8002	C-DIODE	DA2J10100	1	223303R2	
D8002 or	C-DIODE	1SS352	(1)	223234R2	
D8003	C-DIODE	DA2J10100	1	223303R2	
D8003 or	C-DIODE	1SS352	(1)	223234R2	
D8102	C-DIODE	DA2J10100	1	223303R2	
D8102 or	C-DIODE	1SS352	(1)	223234R2	
D8103	DIODE	DAN217T146	1	223285R2	
D8103 or	DIODE	KDS123S	(1)	223312R2	
D8145	ESD D	AOZ8804ADI	1	225502R2	
D8146	ESD D	AOZ8804ADI	1	225502R2	
D8301	ZENER D	DZ2J036M0L	1	224760360R2	

D8301 or	ZENER D	UDZS3.6B	(1)	224550360R2
D8345	ESD D	AOZ8804ADI	1	225502R2
D8346	ESD D	AOZ8804ADI	1	225502R2
D8347	DIODE	DAN217T146	1	223285R2
D8347 or	DIODE	KDS123S	(1)	223312R2
D8701	C-DIODE	DA2J10100	1	223303R2
D8701 or	C-DIODE	1SS352	(1)	223234R2
D8902	C-DIODE	DA2J10100	1	223303R2
D8902 or	C-DIODE	1SS352	(1)	223234R2
D8903	C-DIODE	DA2J10100	1	223303R2
D8903 or	C-DIODE	1SS352	(1)	223234R2
D8904	C-DIODE	DA2J10100	1	223303R2
D8904 or	C-DIODE	1SS352	(1)	223234R2
D8906	C-DIODE	DA2J10100	1	223303R2
D8906 or	C-DIODE	1SS352	(1)	223234R2
D8907	C-DIODE	DA2J10100	1	223303R2
D8907 or	C-DIODE	1SS352	(1)	223234R2
D8908	C-DIODE	DA2J10100	1	223303R2
D8908 or	C-DIODE	1SS352	(1)	223234R2
D8909	C-DIODE	DA2J10100	1	223303R2
D8909 or	C-DIODE	1SS352	(1)	223234R2
D8962	DIODE	RB050M-30GTR	1	22380373R2
Q1001	IC	TC7SZU04FU	1	22242512R2TO
Q1002	IC	PCM1754DBQR	1	22242598R2
Q1004	IC	PCM1690DCAR	1	22242599R2
Q1005	IC	PCM9211PTR	1	22242703R2
Q1090	IC	S-1172B50-U5T1G	1	22242765R2
Q1091	IC	BU33TD3WG-TR	1	22242715R2
Q3001	IC	D830K013DZKB400	1	22242851R3
Q3002	IC(DSP)	TC58DVM92A5TA10B3H(0632)	1	222W0125R306326
Q3003	IC	EM63A165TSB-6G	1	22242829R2
Q3003 or	IC	K4S561632J-UC75	(1)	22242524AR3
Q3003 or	IC	A3V56S40FTP-G6	(1)	22242764R2
Q3003 or	IC	A3V56S40GTP-60RX	(1)	22242891R2
Q3004	IC	EM63A165TSB-6G	1	22242829R2
Q3004 or	IC	K4S561632J-UC75	(1)	22242524AR3
Q3004 or	IC	A3V56S40FTP-G6	(1)	22242764R2
Q3004 or	IC	A3V56S40GTP-60RX	(1)	22242891R2
Q3005	IC	TC7W32FU	1	22241162R2
Q3006	IC	S-80127CNMC-JKM-T2	1	22241642R2
Q3070	IC	FP6861C-B1AS5CT	1	22242840R2
Q3103	IC	BU18TD3WG-TR	1	22242716R2
Q3106	IC	BU33TD3WG-TR	1	22242715R2
Q3107	IC	BU33TD3WG-TR	1	22242715R2
Q3108	IC	KSZ8051RNL(REVA2)	1	22242723AR2
Q3109	IC	S-13A1A12-U5T1U3	1	22242841R2
Q3109 or	IC	S-1172B12-U5T1G	(1)	22242777R2
Q3113	TR	KRC104S	1	2216210R2
Q3113 or	TR	RN1404	(1)	2214490R2
Q3115	TR	KRC104S	1	2216210R2
Q3115 or	TR	RN1404	(1)	2214490R2
Q3120	IC	FP6861C-B1AS5CT	1	22242840R2
Q3121	IC	FP6861C-B1AS5CT	1	22242840R2
Q7001	IC	BR25S640FJ	1	22242761R2
Q7001 or	IC	R1EX25064ASA00A	(1)	22242581R2
Q7001 or	IC	M95640-WMN6TP	(1)	22242643R2
Q7002	TR	KRA102S	1	2216220R2
Q7002 or	TR	RN2402	(1)	2214530R2
Q7003	TR	KRA102S	1	2216220R2
Q7003 or	TR	RN2402	(1)	2214530R2
Q7004	TR	KRA102S	1	2216220R2
Q7004 or	TR	RN2402	(1)	2214530R2
Q7005	TR	KRC104S	1	2216210R2
Q7005 or	TR	RN1404	(1)	2214490R2
Q7006	TR	KRC104S	1	2216210R2
Q7006 or	TR	RN1404	(1)	2214490R2
Q7007	TR	KRC104S	1	2216210R2
Q7007 or	TR	RN1404	(1)	2214490R2
Q7009	IC(MAIN)	MPD70F3477AGJA-GAE-G(0625)	1	222W0117R306250
Q7011	TR	KRA107S	1	2216350R2
Q7011 or	TR	RN2407(TE85L_F)	(1)	2216360R2
Q7012	TR	KRA107S	1	2216350R2
Q7012 or	TR	RN2407(TE85L_F)	(1)	2216360R2
Q7013	IC	SN74CB3Q3305PWR	1	22242258R2
Q7014	TR	KRC102S	1	2216190R2
Q7014 or	TR	RN1402	(1)	2214470R2

Q7015	TR	KRC102S	1	2216190R2
Q7015 or	TR	RN1402	(1)	2214470R2
Q7016	TR	KRC105S	1	2217290R2
Q7016 or	TR	RN1405	(1)	2214500R2
Q7017	TR	KRC104S	1	2216210R2
Q7017 or	TR	RN1404	(1)	2214490R2
Q7018	IC	S-812C33AUA-C2N	1	22242222R2
Q7019	IC	S-812C56AUA-C3K	1	22242207R2
Q7020	IC	S-80127CNMC-JKM-T2	1	22241642R2
Q7021	TR	KRA102S	1	2216220R2
Q7021 or	TR	RN2402	(1)	2214530R2
Q7023	TR	KRC104S	1	2216210R2
Q7023 or	TR	RN1404	(1)	2214490R2
Q7025	TR	2SA1162-GR	1	2214375R2
Q7025 or	TR	KTA1504-GR	(1)	2216185R2
Q7026	TR	KRC104S	1	2216210R2
Q7026 or	TR	RN1404	(1)	2214490R2
Q8001	IC	88DE2755B0-BIF2C000	1	22242752R3
Q8002	IC	S-13A1A11-U5T1U3	1	22242847R2
Q8010	IC	BU18TD3WG-TR	1	22242716R2
Q8011	IC	S-13A1A15-U5T1U3	1	22242842R2
Q8011 or	IC	S-1172B15-U5T1G	(1)	22242778R2
Q8012	IC	TPS51100DGQR	1	22242711R2
Q8030	IC	TC7WHU04FU(TE12L)	1	22242231R2
Q8031	IC	NC7SZ08P5X_F042	1	22242482R2
Q8032	IC	SN74CB3T3306DCT	1	22242454R2
Q8040	IC(VSP)	W25Q128BVF0627	1	222W0116R20627A
Q8041	IC	TC74LCX125FT(EL_K)	1	22274125BR2TO
Q8050	IC	MM3404A50NRE	1	22242701R2
Q8080	IC	K4B1G1646G-BCK0	1	22242710R3
Q8151	IC	TC74VHC157FT	1	22274157ER2TO
Q8201	IC	PS331TQFP64GTR	1	22242788R2
Q8202	IC	ADV7180KCP32Z	1	22242763R3
Q8203	IC	BU18TD3WG-TR	1	22242716R2
Q8205	IC	BU18TD3WG-TR	1	22242716R2
Q8206	TR	KRC104S	1	2216210R2
Q8206 or	TR	RN1404	(1)	2214490R2
Q8207	TR	KRC104S	1	2216210R2
Q8207 or	TR	RN1404	(1)	2214490R2
Q8302	IC	SI99573CTUC	1	22242762R3
Q8303	TR	2SA1162-GR	1	2214375R2
Q8303 or	TR	KTA1504-GR	(1)	2216185R2
Q8305	IC(VSP2)	EN25QH16-104HIP(0631)	1	222W0130R20631B
Q8307	IC	XC6221B132MR	1	22242809R2
Q8308	TR	RN2401(TE85L_F)	1	2214520R2
Q8308 or	TR	KRA101S	(1)	2217840R2
Q8309	TR	KRC104S	1	2216210R2
Q8309 or	TR	RN1404	(1)	2214490R2
Q8501	IC	PCA9515ADRGR	1	22242817R2
Q8502	IC	NC7SZ08P5X_F042	1	22242482R2
Q8601	IC	BD82065FVJ	1	22242718R2
Q8685	TR ARRAY	UM6K1N	1	226066R2
Q8685 or	TR ARRAY	UPA672T	(1)	226067R2
Q8685 or	TR ARRAY	RT3K66M-T111-1	(1)	226069R2
Q8687	TR	RN2401(TE85L_F)	1	2214520R2
Q8688	TR	KRC104S	1	2216210R2
Q8693	IC	MM3404A50NRE	1	22242701R2
Q8701	IC(HDMI/VIDEO)	TMPM361F10FG(0626)	1	222W0115R306265
Q8702	TR ARRAY	UM6K1N	1	226066R2
Q8702 or	TR ARRAY	UPA672T	(1)	226067R2
Q8702 or	TR ARRAY	RT3K66M-T111-1	(1)	226069R2
Q8710	TR	2SC2712-GR	1	2213145R2
Q8710 or	TR	KTC3875-GR	(1)	2216175R2
Q8711	TR	2SA1201-Y(TE12L,CF)	1	2217554R2
Q8741	IC	TC74LCX125FT(EL_K)	1	22274125BR2TO
Q8901	IC	TC74VHC08AFT	1	22274008GR2TO
Q8901 or	IC	TC74VHC08AFT(EKJ)	(1)	22274008G1R2TO
Q8911	TR	KRC104S	1	2216210R2
Q8911 or	TR	RN1404	(1)	2214490R2
Q8931	IC	FR9888CSPCTR	1	22242839R2
Q8932	IC	TPS22924CZPZR	1	22242807R2
Q8933	TR	KRC105S	1	2217290R2
Q8941	IC	FR9888CSPCTR	1	22242839R2
Q8942	IC	TPS22924CZPZR	1	22242807R2
Q8943	TR	KRC104S	1	2216210R2
Q8951	IC	FR9888CSPCTR	1	22242839R2

Q8952	IC	TPS22924CZ5PR	1	22242807R2
Q8953	TR	KRC104S	1	2216210R2
Q8961	IC	FR9888CSPCTR	1	22242839R2
[TRANS COIL]				
L1001	CORE	BLM18PG181SN1D	1	2350005R1
L1002	CHOKE COIL	LBC2518T4R7M	1	231364M047R2
L1003	EMIFIL	BK1608LL241-T	1	230959R1
L1004	EMIFIL	BK1608LL241-T	1	230959R1
L1005	EMIFIL	BK1608LL241-T	1	230959R1
L1006	EMIFIL	BK1608LL241-T	1	230959R1
L1007	EMIFIL	BK1608LL241-T	1	230959R1
L1009	CHOKE COIL	LBC2518T4R7M	1	231364M047R2
L1010	CHOKE COIL	LBC2518T4R7M	1	231364M047R2
L1011	CHOKE COIL	LBC2518T4R7M	1	231364M047R2
L1012	CHOKE COIL	LBC2518T4R7M	1	231364M047R2
L1013	CHOKE COIL	LBC2518T4R7M	1	231364M047R2
L1090	CORE	BLM18PG181SN1D	1	2350005R1
L3001	CORE	BLM18PG121SN1D	1	2350006R1
L3002	CORE	BLM18PG121SN1D	1	2350006R1
L3003	CORE	BLM18PG121SN1D	1	2350006R1
L3004	CORE	BLM18PG121SN1D	1	2350006R1
L3005	CORE	BLM18PG121SN1D	1	2350006R1
L3101	CORE	DLP11SA900HL2L	1	2350021R2
L3102	CORE	BLM18PG181SN1D	1	2350005R1
L3103	CORE	BLM18PG121SN1D	1	2350006R1
L3104	CORE	BLM18PG121SN1D	1	2350006R1
L3105	CORE	BLM18PG121SN1D	1	2350006R1
L3106	CORE	BLM18PG121SN1D	1	2350006R1
L3107	CORE	BLM18PG121SN1D	1	2350006R1
L3108	CORE	BLM18PG121SN1D	1	2350006R1
L3109	CORE	BLM18PG121SN1D	1	2350006R1
L3110	CORE	BLM18PG121SN1D	1	2350006R1
L3111	CORE	BLM18PG121SN1D	1	2350006R1
L3112	CORE	DLP11SA900HL2L	1	2350021R2
L3114	CORE	BLM18PG121SN1D	1	2350006R1
L3120	CORE	BLM18PG181SN1D	1	2350005R1
L3145	CORE	DLP2ADN900HL4L	1	230990R2
L3203	EMIFIL	BK1608LL241-T	1	230959R1
L3209	EMIFIL	BK1608LL241-T	1	230959R1
L7001	CORE	BLM18PG181SN1D	1	2350005R1
L7003	CHOKE COIL	BLM21PG221SN1	1	230949R2
L7004	CORE	BLM18PG181SN1D	1	2350005R1
L7006	CORE	BLM18PG181SN1D	1	2350005R1
L7007	CORE	BLM18PG181SN1D	1	2350005R1
L8001	CORE	BLM18PG181SN1D	1	2350005R1
L8002	CORE	BLM18PG181SN1D	1	2350005R1
L8003	CORE	BLM18PG181SN1D	1	2350005R1
L8004	CORE	BLM18PG181SN1D	1	2350005R1
L8005	CORE	BLM18PG181SN1D	1	2350005R1
L8006	CORE	BLM18PG121SN1D	1	2350006R1
L8007	CORE	BLM18PG181SN1D	1	2350005R1
L8008	CORE	BLM18PG181SN1D	1	2350005R1
L8009	CORE	BLM18PG181SN1D	1	2350005R1
L8010	CORE	BLM18PG181SN1D	1	2350005R1
L8011	CORE	BLM18PG181SN1D	1	2350005R1
L8012	CORE	BLM18PG181SN1D	1	2350005R1
L8013	CORE	BLM18PG181SN1D	1	2350005R1
L8015	CORE	BLM18PG181SN1D	1	2350005R1
L8016	CORE	BLM18PG181SN1D	1	2350005R1
L8081	CORE	BLM18PG181SN1D	1	2350005R1
L8082	C-R NET	MNR12E0APJ000	1	43464900002R2
L8082 or	C-R NET	YCN162-000-ZL	(1)	43464B00002R1
L8083	C-R NET	MNR12E0APJ000	1	43464900002R2
L8083 or	C-R NET	YCN162-000-ZL	(1)	43464B00002R1
L8084	C-R NET	MNR12E0APJ000	1	43464900002R2
L8084 or	C-R NET	YCN162-000-ZL	(1)	43464B00002R1
L8085	C-R NET	MNR12E0APJ000	1	43464900002R2
L8085 or	C-R NET	YCN162-000-ZL	(1)	43464B00002R1
L8086	CORE	BLM18PG181SN1D	1	2350005R1
L8151	CORE	BLM18PG181SN1D	1	2350005R1
L8202	CORE	BLM18PG181SN1D	1	2350005R1
L8203	CORE	BLM18PG181SN1D	1	2350005R1
L8205	CORE	BLM18PG181SN1D	1	2350005R1
L8206	CORE	BLM18PG181SN1D	1	2350005R1
L8207	CORE	BLM18PG181SN1D	1	2350005R1
L8210	CORE	BLM18PG181SN1D	1	2350005R1

L8302	CORE	BLM18PG181SN1D	1	2350005R1
L8303	CORE	BLM18PG181SN1D	1	2350005R1
L8304	CORE	BLM18PG181SN1D	1	2350005R1
L8305	CORE	BLM18PG181SN1D	1	2350005R1
L8306	CORE	BLM18PG181SN1D	1	2350005R1
L8307	CORE	BLM18PG181SN1D	1	2350005R1
L8308	CORE	BLM18PG181SN1D	1	2350005R1
L8309	EMIFIL	BK1608LL241-T	1	230959R1
L8500	CORE	BLM18PG181SN1D	1	2350005R1
L8501	CORE	BLM18PG181SN1D	1	2350005R1
L8601	CORE	BLM18PG181SN1D	1	2350005R1
L8602	CORE	BLM18PG181SN1D	1	2350005R1
L8604	CORE	BLM18PG181SN1D	1	2350005R1
L8687	CORE	BLM18PG181SN1D	1	2350005R1
L8701	CORE	BLM18PG181SN1D	1	2350005R1
L8710	CORE	BLM18PG181SN1D	1	2350005R1
L8931	CHOKE COIL	BLM21PG221SN1	1	230949R2
L8932	CHOKE COIL	1264EY-100M=P3	1	231447M100R2
L8933	CHOKE COIL	BLM21PG221SN1	1	230949R2
L8934	CHOKE COIL	BLM21PG221SN1	1	230949R2
L8941	CHOKE COIL	BLM21PG221SN1	1	230949R2
L8942	CHOKE COIL	1264EY-100M=P3	1	231447M100R2
L8943	CHOKE COIL	BLM21PG221SN1	1	230949R2
L8944	CHOKE COIL	BLM21PG221SN1	1	230949R2
L8951	CHOKE COIL	BLM21PG221SN1	1	230949R2
L8952	CHOKE COIL	1264EY-100M=P3	1	231447M100R2
L8953	CHOKE COIL	BLM21PG221SN1	1	230949R2
L8954	CHOKE COIL	BLM21PG221SN1	1	230949R2
L8961	CHOKE COIL	BLM21PG221SN1	1	230949R2
L8962	CHOKE COIL	1264EY-100M=P3	1	231447M100R2
L8963	CHOKE COIL	BLM21PG221SN1	1	230949R2
L8964	CHOKE COIL	BLM21PG221SN1	1	230949R2
L8965	CORE	BLM18PG181SN1D	1	2350005R1
X1001	CRYSTAL	HC-49S 9C11.2896M	1	3010513R2
X1002	CRYSTAL	HC-49S 9C24.5760M	1	3010516R2
X3001	CRYSTAL	HC-49S 9C20.0000M	1	3010514R2
X7001	CERA LOCK	CSTCR5M00G53-B0	1	3010356R2
X8001	CRYSTAL	HC-49S 9C20.0000M	1	3010514R2
X8201	CRYSTAL	HC-49S 9C28.6363M	1	3010519R2
X8301	CRYSTAL	HC-49S 9C27.0000M	1	3010518R2
X8701	CERA LOCK	CSTCE8M00G55-R0	1	3010416R2
[CAPACITOR]				
C1001	C-CERA C	CK725B1C-104K0	1	332011045R1
C1003	C-CERA C	CK732B16V-106K	1	332071065R2
C1004	C-CERA C	CK732B16V-106K	1	332071065R2
C1005	C-CERA C	CK725B1C-104K0	1	332011045R1
C1006	C-CERA C	CK725B1C-104K0	1	332011045R1
C1007	C-CERA C	CK732B16V-106K	1	332071065R2
C1008	C-CERA C	CC725CH1H-180J0	1	342031804R1
C1009	C-CERA C	CC725CH1H-180J0	1	342031804R1
C1011	C-CERA C	CK725B1C-104K0	1	332011045R1
C1012	CHIP ELECT C	CEWX4V-220M	1	3981G2217R2
C1013	C-CERA C	CK725B1C-104K0	1	332011045R1
C1014	C-CERA C	CK725B1C-104K0	1	332011045R1
C1015	CHIP ELECT C	CEWX16V-47M	1	398144707R2
C1016	C-CERA C	CK725B1C-104K0	1	332011045R1
C1017	CHIP ELECT C	CEWX16V-100M	1	398141017R2
C1018	C-CERA C	CK725B1C-104K0	1	332011045R1
C1019	C-CERA C	CK732B16V-106K	1	332071065R2
C1020	CHIP ELECT C	CEWX4V-220M	1	3981G2217R2
C1021	C-CERA C	CK725B1H-472K0	1	332034725R1
C1022	CHIP ELECT C	CEWX16V-47M	1	398144707R2
C1023	CHIP ELECT C	CEWX16V-100M	1	398141017R2
C1024	C-CERA C	CK732B16V-106K	1	332071065R2
C1025	C-CERA C	CK725B1H-223K0	1	332032235R1
C1026	C-CERA C	CK725B1E-473K0	1	332024735R1
C1027	CHIP ELECT C	CEWX4V-220M	1	3981G2217R2
C1028	C-CERA C	CC725CH1H-150J0	1	342031504R1
C1029	C-CERA C	CC725CH1H-180J0	1	342031804R1
C1030	C-CERA C	CK732B16V-106K	1	332071065R2
C1090	C-CERA C	CK732B16V-106K	1	332071065R2
C1091	C-CERA C	CK725B0J-226M	1	332092267R2
C1092	C-CERA C	CK732B16V-106K	1	332071065R2
C1093	C-CERA C	CK732B16V-106K	1	332071065R2
C1094	C-CERA C	CK732B16V-106K	1	332071065R2
C3001	C-CERA C	CK725B1A-105K0	1	332001055R1

C3002	C-CERA C	CK725B1A-105K0	1	332001055R1
C3003	C-CERA C	CK732B16V-106K	1	332071065R2
C3004	C-CERA C	CK732B16V-106K	1	332071065R2
C3005	C-CERA C	CK725B1A-105K0	1	332001055R1
C3006	C-CERA C	CK725B1H-102K0	1	332031025R1
C3007	C-CERA C	CK725B1A-105K0	1	332001055R1
C3008	C-CERA C	CK725B1H-102K0	1	332031025R1
C3009	C-CERA C	CK725B1A-105K0	1	332001055R1
C3010	C-CERA C	CK725B1A-105K0	1	332001055R1
C3011	C-CERA C	CK725B1A-105K0	1	332001055R1
C3012	C-CERA C	CK725B1H-102K0	1	332031025R1
C3013	C-CERA C	CK725B1A-105K0	1	332001055R1
C3014	C-CERA C	CK725B1H-102K0	1	332031025R1
C3015	C-CERA C	CK725B1H-102K0	1	332031025R1
C3016	C-CERA C	CK725B1A-105K0	1	332001055R1
C3017	C-CERA C	CK725B1A-105K0	1	332001055R1
C3018	C-CERA C	CK725B1A-105K0	1	332001055R1
C3019	C-CERA C	CK725B1H-102K0	1	332031025R1
C3020	C-CERA C	CK725B1A-105K0	1	332001055R1
C3021	C-CERA C	CK725B1A-105K0	1	332001055R1
C3022	C-CERA C	CK725B1A-105K0	1	332001055R1
C3023	C-CERA C	CK732B16V-106K	1	332071065R2
C3024	C-CERA C	CK725B1H-102K0	1	332031025R1
C3025	C-CERA C	CK725B1A-105K0	1	332001055R1
C3026	C-CERA C	CK725B1C-104K0	1	332011045R1
C3027	C-CERA C	CK725B1H-102K0	1	332031025R1
C3028	C-CERA C	CK725B1A-105K0	1	332001055R1
C3029	C-CERA C	CK725B1H-102K0	1	332031025R1
C3030	C-CERA C	CK725B1A-105K0	1	332001055R1
C3031	C-CERA C	CK725B1A-105K0	1	332001055R1
C3032	C-CERA C	CK725B1H-102K0	1	332031025R1
C3033	C-CERA C	CK725B1A-105K0	1	332001055R1
C3034	C-CERA C	CC725CH1H-270J0	1	342032704R1
C3035	C-CERA C	CK725B1H-102K0	1	332031025R1
C3036	C-CERA C	CC725CH1H-270J0	1	342032704R1
C3037	C-CERA C	CK725B1A-105K0	1	332001055R1
C3038	C-CERA C	CK725B1A-105K0	1	332001055R1
C3039	C-CERA C	CK725B1H-103K0	1	332031035R1
C3040	C-CERA C	CK725B1A-105K0	1	332001055R1
C3041	C-CERA C	CK732B16V-106K	1	332071065R2
C3042	C-CERA C	CK725B1A-105K0	1	332001055R1
C3043	C-CERA C	CK725B1A-105K0	1	332001055R1
C3070	C-CERA C	CK725B0J-226M	1	332092267R2
C3071	C-CERA C	CK725B0J-226M	1	332092267R2
C3101	C-CERA C	CK732B16V-106K	1	332071065R2
C3102	C-CERA C	CK725B0J-226M	1	332092267R2
C3103	C-CERA C	CK725B1H-102K0	1	332031025R1
C3105	C-CERA C	CK725B1A-105K0	1	332001055R1
C3106	C-CERA C	CK732B16V-106K	1	332071065R2
C3107	C-CERA C	CK725B1A-105K0	1	332001055R1
C3108	C-CERA C	CK725B1A-105K0	1	332001055R1
C3109	C-CERA C	CK732B16V-106K	1	332071065R2
C3110	C-CERA C	CK725B1A-224K0	1	332002245R1
C3111	C-CERA C	CK732B16V-106K	1	332071065R2
C3112	C-CERA C	CK732B16V-106K	1	332071065R2
C3113	C-CERA C	CK725B1A-105K0	1	332001055R1
C3114	C-CERA C	CK725B1A-105K0	1	332001055R1
C3115	C-CERA C	CK732B16V-106K	1	332071065R2
C3116	C-CERA C	CK732B16V-106K	1	332071065R2
C3117	C-CERA C	CK725B1H-102K0	1	332031025R1
C3118	C-CERA C	CK725B1A-105K0	1	332001055R1
C3119	C-CERA C	CK725B1A-105K0	1	332001055R1
C3120	C-CERA C	CK732B16V-106K	1	332071065R2
C3121	C-CERA C	CK725B1A-105K0	1	332001055R1
C3122	C-CERA C	CK725B1A-105K0	1	332001055R1
C3123	C-CERA C	CK725B1A-105K0	1	332001055R1
C3124	C-CERA C	CK732B16V-106K	1	332071065R2
C3125	C-CERA C	CK725B1A-105K0	1	332001055R1
C3126	C-CERA C	CK732B16V-106K	1	332071065R2
C3127	C-CERA C	CK725B1A-105K0	1	332001055R1
C3128	C-CERA C	CK725B1A-105K0	1	332001055R1
C3129	C-CERA C	CK725B1A-105K0	1	332001055R1
C3130	C-CERA C	CK732B16V-106K	1	332071065R2
C3131	C-CERA C	CK725B1A-105K0	1	332001055R1
C3132	C-CERA C	CC725CH1H-101J0	1	342031014R1
C3133	C-CERA C	CK725B1A-105K0	1	332001055R1

C3136	C-CERA C	CK725B1A-105K0	1	332001055R1
C3137	C-CERA C	CK725B1A-105K0	1	332001055R1
C3138	C-CERA C	CK725B1A-105K0	1	332001055R1
C3139	C-CERA C	CK725B1A-105K0	1	332001055R1
C3140	C-CERA C	CK725B1A-105K0	1	332001055R1
C3141	C-CERA C	CK725B1C-104K0	1	332011045R1
C3142	C-CERA C	CK725B1A-105K0	1	332001055R1
C3143	C-CERA C	CK725B1A-105K0	1	332001055R1
C3144	C-CERA C	CK725B1A-105K0	1	332001055R1
C3145	C-CERA C	CK732B16V-106K	1	332071065R2
C3148	C-CERA C	CK725B1C-104K0	1	332011045R1
C3149	C-CERA C	CK725B1H-102K0	1	332031025R1
C3150	C-CERA C	CK725B0J-226M	1	332092267R2
C3152	C-CERA C	CK725B0J-226M	1	332092267R2
C3153	C-CERA C	CK732B16V-106K	1	332071065R2
C3154	C-CERA C	CK725B1A-105K0	1	332001055R1
C3155	C-CERA C	CK732B16V-106K	1	332071065R2
C3156	C-CERA C	CK725B1A-105K0	1	332001055R1
C3157	C-CERA C	CK725B1A-105K0	1	332001055R1
C3158	C-CERA C	CK725B1A-105K0	1	332001055R1
C3159	C-CERA C	CK725B1A-105K0	1	332001055R1
C3160	C-CERA C	CK725B1A-105K0	1	332001055R1
C3161	C-CERA C	CK725B1A-105K0	1	332001055R1
C3162	C-CERA C	CK725B1H-102K0	1	332031025R1
C3163	C-CERA C	CK732B16V-106K	1	332071065R2
C3164	C-CERA C	CK725B1H-102K0	1	332031025R1
C3165	C-CERA C	CK725B0J-226M	1	332092267R2
C3166	C-CERA C	CK732B16V-106K	1	332071065R2
C3201	C-CERA C	CK732B16V-106K	1	332071065R2
C3202	C-CERA C	CK732B16V-106K	1	332071065R2
C7002	C-CERA C	CK725B1H-102K0	1	332031025R1
C7003	C-CERA C	CK725B1H-102K0	1	332031025R1
C7004	C-CERA C	CK725B1C-104K0	1	332011045R1
C7005	C-CERA C	CK725B1C-104K0	1	332011045R1
C7006	CHIP ELECT C	CEW T6.3V-470M	1	395724717R2
C7008	C-CERA C	CK725B50V-224K	1	332242245R1
C7009	C-CERA C	CK725B1A-105K0	1	332001055R1
C7010	C-CERA C	CK732B1C-474K	1	337394745R1
C7011	C-CERA C	CK725B1A-105K0	1	332001055R1
C7012	C-CERA C	CK732B1C-474K	1	337394745R1
C7013	C-CERA C	CK725B1A-105K0	1	332001055R1
C7015	C-CERA C	CK725B1C-104K0	1	332011045R1
C7016	C-CERA C	CK725B1C-104K0	1	332011045R1
C7017	C-CERA C	CK725B1C-104K0	1	332011045R1
C7018	C-CERA C	CK725B1C-104K0	1	332011045R1
C7019	C-CERA C	CK725B1C-104K0	1	332011045R1
C7020	C-CERA C	CK732B16V-106K	1	332071065R2
C7030	C-CERA C	CK725B1H-102K0	1	332031025R1
C7031	C-CERA C	CK725B1H-102K0	1	332031025R1
C7032	C-CERA C	CK725B1C-104K0	1	332011045R1
C7033	C-CERA C	CG725CH1H-101J0	1	342031014R1
C7034	C-CERA C	CC725CH1H-101J0	1	342031014R1
C7035	C-CERA C	CK725B1C-104K0	1	332011045R1
C7036	C-CERA C	CK725B1C-104K0	1	332011045R1
C7037	C-CERA C	CK725B0J-226M	1	332092267R2
C7038	C-CERA C	CK732B16V-106K	1	332071065R2
C7039	C-CERA C	CK732B16V-106K	1	332071065R2
C7040	C-CERA C	CK725B1E-106K	1	332221065R2
C7041	C-CERA C	CK732B16V-106K	1	332071065R2
C7042	C-CERA C	CK725B1C-104K0	1	332011045R1
C7043	C-CERA C	CK725B1C-104K0	1	332011045R1
C7044	C-CERA C	CK725B1C-104K0	1	332011045R1
C7045	C-CERA C	CK725B1C-104K0	1	332011045R1
C7050	C-CERA C	CK732B1C-474K	1	337394745R1
C7051	C-CERA C	CK725B1A-105K0	1	332001055R1
C7301	C-CERA C	CK725B1H-102K0	1	332031025R1
C7302	C-CERA C	CK725B1H-102K0	1	332031025R1
C7303	C-CERA C	CK725B1H-102K0	1	332031025R1
C7304	C-CERA C	CK725B1H-102K0	1	332031025R1
C7310	C-CERA C	CK725B1A-105K0	1	332001055R1
C7313	C-CERA C	CK725B1H-102K0	1	332031025R1
C8001	C-CERA C	CK725B1H-102K0	1	332031025R1
C8002	C-CERA C	CK732B16V-106K	1	332071065R2
C8003	C-CERA C	CK732B16V-106K	1	332071065R2
C8004	C-CERA C	CK725B1C-104K0	1	332011045R1
C8005	C-CERA C	CK732B16V-106K	1	332071065R2

C8090	C-CERA C	CK725B1A-105K0	1	332001055R1
C8091	C-CERA C	CK725B1A-105K0	1	332001055R1
C8092	C-CERA C	CK725B1A-105K0	1	332001055R1
C8093	C-CERA C	CK725B1A-105K0	1	332001055R1
C8094	C-CERA C	CK725B1A-105K0	1	332001055R1
C8095	C-CERA C	CK732B16V-106K	1	332071065R2
C8096	C-CERA C	CK725B1A-105K0	1	332001055R1
C8097	C-CERA C	CK732B16V-106K	1	332071065R2
C8098	C-CERA C	CK725B1A-105K0	1	332001055R1
C8100	C-CERA C	CK725B1H-102K0	1	332031025R1
C8101	C-CERA C	CK725B1H-102K0	1	332031025R1
C8103	C-CERA C	CK725B1A-105K0	1	332001055R1
C8104	C-CERA C	CK725B0J-226M	1	332092267R2
C8105	C-CERA C	CK725B1A-105K0	1	332001055R1
C8106	C-CERA C	CK725B1A-105K0	1	332001055R1
C8107	C-CERA C	CK725B1C-104K0	1	332011045R1
C8108	C-CERA C	CK725B1C-104K0	1	332011045R1
C8109	C-CERA C	CK725B1A-105K0	1	332001055R1
C8110	C-CERA C	CK725B1A-105K0	1	332001055R1
C8111	C-CERA C	CC725CH1H-101J0	1	342031014R1
C8112	C-CERA C	CK725B1C-104K0	1	332011045R1
C8113	C-CERA C	CK725B1C-104K0	1	332011045R1
C8114	C-CERA C	CC725CH1H-080C0	1	342030801R1
C8115	C-CERA C	CK725B1C-104K0	1	332011045R1
C8116	C-CERA C	CC725CH1H-220J0	1	342032204R1
C8117	C-CERA C	CC725CH1H-220J0	1	342032204R1
C8124	C-CERA C	CK725B1C-104K0	1	332011045R1
C8125	C-CERA C	CK725B1H-102K0	1	332031025R1
C8126	C-CERA C	CK725B0J-226M	1	332092267R2
C8128	C-CERA C	CK732B16V-106K	1	332071065R2
C8151	C-CERA C	CK732B16V-106K	1	332071065R2
C8152	C-CERA C	CK725B1C-104K0	1	332011045R1
C8153	C-CERA C	CK725B1H-102K0	1	332031025R1
C8201	C-CERA C	CK725B1A-105K0	1	332001055R1
C8202	C-CERA C	CK725B1H-103K0	1	332031035R1
C8203	C-CERA C	CK725B1C-104K0	1	332011045R1
C8204	C-CERA C	CK725B1H-103K0	1	332031035R1
C8205	C-CERA C	CK725B1C-104K0	1	332011045R1
C8206	C-CERA C	CK725B1C-104K0	1	332011045R1
C8207	C-CERA C	CK725B1H-103K0	1	332031035R1
C8208	C-CERA C	CK725B1C-104K0	1	332011045R1
C8210	C-CERA C	CK725B1C-104K0	1	332011045R1
C8211	C-CERA C	CK725B1C-104K0	1	332011045R1
C8212	C-CERA C	CK725B1H-103K0	1	332031035R1
C8213	C-CERA C	CK725B1H-103K0	1	332031035R1
C8214	C-CERA C	CK725B1C-104K0	1	332011045R1
C8215	C-CERA C	CK732B16V-106K	1	332071065R2
C8216	C-CERA C	CK725B1H-102K0	1	332031025R1
C8217	C-CERA C	CK725B1A-105K0	1	332001055R1
C8219	C-CERA C	CK725B1H-103K0	1	332031035R1
C8220	C-CERA C	CK725B1C-104K0	1	332011045R1
C8221	C-CERA C	CK725B1H-103K0	1	332031035R1
C8222	C-CERA C	CK725B1C-104K0	1	332011045R1
C8223	C-CERA C	CK725B1C-104K0	1	332011045R1
C8224	C-CERA C	CK725B1C-104K0	1	332011045R1
C8225	C-CERA C	CK725B1C-104K0	1	332011045R1
C8227	C-CERA C	CK725B1C-104K0	1	332011045R1
C8229	C-CERA C	CK725B1H-103K0	1	332031035R1
C8230	C-CERA C	CK725B1C-104K0	1	332011045R1
C8231	C-CERA C	CK725B1C-104K0	1	332011045R1
C8232	C-CERA C	CK725B1H-103K0	1	332031035R1
C8233	C-CERA C	CK725B1C-104K0	1	332011045R1
C8236	C-CERA C	CC725CH1H-150J0	1	342031504R1
C8237	C-CERA C	CC725CH1H-120J0	1	342031204R1
C8238	C-CERA C	CK725B1A-105K0	1	332001055R1
C8239	C-CERA C	CK725B1H-103K0	1	332031035R1
C8240	C-CERA C	CK725B1C-683K0	1	332016835R1
C8241	C-CERA C	CK725B1E-153K0	1	332021535R1
C8243	C-CERA C	CK732B16V-106K	1	332071065R2
C8245	C-CERA C	CK732B16V-106K	1	332071065R2
C8247	C-CERA C	CK732B16V-106K	1	332071065R2
C8248	C-CERA C	CK732B16V-106K	1	332071065R2
C8249	C-CERA C	CK725B1H-102K0	1	332031025R1
C8250	C-CERA C	CK732B16V-106K	1	332071065R2
C8251	C-CERA C	CK725B1C-104K0	1	332011045R1
C8252	C-CERA C	CK725B1H-103K0	1	332031035R1

C8253	C-CERA C	CK725B1H-103K0	1	332031035R1
C8254	C-CERA C	CK725B1H-103K0	1	332031035R1
C8255	C-CERA C	CK732B16V-106K	1	332071065R2
C8256	C-CERA C	CK725B1A-105K0	1	332001055R1
C8257	C-CERA C	CK732B16V-106K	1	332071065R2
C8258	C-CERA C	CK725B1H-103K0	1	332031035R1
C8259	C-CERA C	CK725B1H-103K0	1	332031035R1
C8260	C-CERA C	CK732B16V-106K	1	332071065R2
C8261	C-CERA C	CK732B16V-106K	1	332071065R2
C8305	C-CERA C	CK725B1H-102K0	1	332031025R1
C8306	C-CERA C	CK725B1C-104K0	1	332011045R1
C8307	C-CERA C	CK725B1H-102K0	1	332031025R1
C8308	C-CERA C	CK725B1C-104K0	1	332011045R1
C8309	C-CERA C	CK725B1H-102K0	1	332031025R1
C8310	C-CERA C	CK725B1C-104K0	1	332011045R1
C8311	C-CERA C	CK725B1H-102K0	1	332031025R1
C8312	C-CERA C	CK725B1C-104K0	1	332011045R1
C8313	C-CERA C	CK725B1H-102K0	1	332031025R1
C8314	C-CERA C	CK725B1C-104K0	1	332011045R1
C8315	C-CERA C	CK725B1H-102K0	1	332031025R1
C8316	C-CERA C	CK725B1C-104K0	1	332011045R1
C8317	C-CERA C	CK725B1H-102K0	1	332031025R1
C8318	C-CERA C	CK725B1C-104K0	1	332011045R1
C8319	C-CERA C	CK725B1C-104K0	1	332011045R1
C8320	C-CERA C	CK725B1H-102K0	1	332031025R1
C8321	C-CERA C	CG725CH1H-120J0	1	342031204R1
C8322	C-CERA C	CK725B1H-102K0	1	332031025R1
C8323	C-CERA C	CK725B1C-104K0	1	332011045R1
C8324	C-CERA C	CK725B1C-104K0	1	332011045R1
C8325	C-CERA C	CG725CH1H-100D0	1	342031002R1
C8326	C-CERA C	CK725B1H-102K0	1	332031025R1
C8327	C-CERA C	CK725B1H-102K0	1	332031025R1
C8328	C-CERA C	CK725B1C-104K0	1	332011045R1
C8329	C-CERA C	CK725B1H-102K0	1	332031025R1
C8330	C-CERA C	CK725B1C-104K0	1	332011045R1
C8331	C-CERA C	CK725B1C-104K0	1	332011045R1
C8332	C-CERA C	CK725B1A-105K0	1	332001055R1
C8333	C-CERA C	CK725B1H-102K0	1	332031025R1
C8334	C-CERA C	CK725B1C-104K0	1	332011045R1
C8335	C-CERA C	CK725B1H-102K0	1	332031025R1
C8336	C-CERA C	CK725B1C-104K0	1	332011045R1
C8337	C-CERA C	CK725B1A-105K0	1	332001055R1
C8338	C-CERA C	CK725B1H-102K0	1	332031025R1
C8339	C-CERA C	CK725B1A-105K0	1	332001055R1
C8340	C-CERA C	CK725B1C-104K0	1	332011045R1
C8341	C-CERA C	CK725B1H-102K0	1	332031025R1
C8342	C-CERA C	CK725B1C-104K0	1	332011045R1
C8343	C-CERA C	CK725B1H-102K0	1	332031025R1
C8344	C-CERA C	CK725B1C-104K0	1	332011045R1
C8345	C-CERA C	CK725B1H-102K0	1	332031025R1
C8347	C-CERA C	CK725B1H-102K0	1	332031025R1
C8348	C-CERA C	CK725B1C-104K0	1	332011045R1
C8349	C-CERA C	CK725B1A-105K0	1	332001055R1
C8350	C-CERA C	CK725B1A-105K0	1	332001055R1
C8351	C-CERA C	CK725B1A-105K0	1	332001055R1
C8352	C-CERA C	CK732B16V-106K	1	332071065R2
C8353	C-CERA C	CK725B1C-104K0	1	332011045R1
C8354	C-CERA C	CK725B1A-105K0	1	332001055R1
C8356	C-CERA C	CK732B16V-106K	1	332071065R2
C8357	C-CERA C	CK732B16V-106K	1	332071065R2
C8358	C-CERA C	CK725B1H-102K0	1	332031025R1
C8359	C-CERA C	CK732B16V-106K	1	332071065R2
C8360	C-CERA C	CK725B1C-104K0	1	332011045R1
C8361	C-CERA C	CK725B1H-102K0	1	332031025R1
C8362	C-CERA C	CK725B1C-104K0	1	332011045R1
C8363	C-CERA C	CK725B1H-102K0	1	332031025R1
C8364	C-CERA C	CK725B1C-104K0	1	332011045R1
C8366	C-CERA C	CK732B16V-106K	1	332071065R2
C8367	C-CERA C	CK732B16V-106K	1	332071065R2
C8368	C-CERA C	CK732B16V-106K	1	332071065R2
C8383	C-CERA C	CK725B1C-104K0	1	332011045R1
C8384	C-CERA C	CK732B16V-106K	1	332071065R2
C8386	C-CERA C	CK725B1H-102K0	1	332031025R1
C8387	C-CERA C	CK725B1H-102K0	1	332031025R1
C8500	C-CERA C	CK732B16V-106K	1	332071065R2
C8501	C-CERA C	CK725B1C-104K0	1	332011045R1

C8516	C-CERA C	CK725F1E-104Z1	1	332161040R1
C8517	C-CERA C	CK725F1E-104Z1	1	332161040R1
C8518	C-CERA C	CK725B1C-104K0	1	332011045R1
C8519	C-CERA C	CK725B1E-473K0	1	332024735R1
C8520	C-CERA C	CK725B1H-102K0	1	332031025R1
C8601	C-CERA C	CK732B16V-106K	1	332071065R2
C8602	C-CERA C	CK725B1H-102K0	1	332031025R1
C8603	C-CERA C	CK732B16V-106K	1	332071065R2
C8604	C-CERA C	CK725B1H-102K0	1	332031025R1
C8605	C-CERA C	CK725B1C-104K0	1	332011045R1
C8606	C-CERA C	CK725B0J-226M	1	332092267R2
C8608	C-CERA C	CK725B0J-226M	1	332092267R2
C8611	C-CERA C	CK725B1H-102K0	1	332031025R1
C8612	C-CERA C	CK725B1H-102K0	1	332031025R1
C8621	C-CERA C	CK725B1H-102K0	1	332031025R1
C8622	C-CERA C	CK725B1H-102K0	1	332031025R1
C8631	C-CERA C	CK725B1H-102K0	1	332031025R1
C8632	C-CERA C	CK725B1H-102K0	1	332031025R1
C8641	C-CERA C	CK725B1H-102K0	1	332031025R1
C8642	C-CERA C	CK725B1H-102K0	1	332031025R1
C8651	C-CERA C	CK725B1H-102K0	1	332031025R1
C8652	C-CERA C	CK725B1H-102K0	1	332031025R1
C8661	C-CERA C	CK725B1H-102K0	1	332031025R1
C8662	C-CERA C	CK725B1H-102K0	1	332031025R1
C8671	C-CERA C	CK725B1H-102K0	1	332031025R1
C8672	C-CERA C	CK725B1H-102K0	1	332031025R1
C8678	C-CERA C	CK732B16V-106K	1	332071065R2
C8679	C-CERA C	CK732B16V-106K	1	332071065R2
C8701	C-CERA C	CK725B1C-104K0	1	332011045R1
C8702	C-CERA C	CK725B1C-104K0	1	332011045R1
C8703	C-CERA C	CK725B1C-104K0	1	332011045R1
C8704	C-CERA C	CK725B1C-104K0	1	332011045R1
C8705	C-CERA C	CK725B1A-105K0	1	332001055R1
C8706	C-CERA C	CK725B1C-104K0	1	332011045R1
C8707	C-CERA C	CK725B1C-104K0	1	332011045R1
C8708	C-CERA C	CK732B16V-106K	1	332071065R2
C8709	C-CERA C	CK732B16V-106K	1	332071065R2
C8710	C-CERA C	CK732B16V-106K	1	332071065R2
C8741	C-CERA C	CK725B1C-104K0	1	332011045R1
C8902	C-CERA C	CK725B1E-106K	1	332221065R2
C8903	C-CERA C	CK725B1E-106K	1	332221065R2
C8904	C-CERA C	CK725B1A-105K0	1	332001055R1
C8906	C-CERA C	CK725B1C-104K0	1	332011045R1
C8907	C-CERA C	CK725B1A-105K0	1	332001055R1
C8908	C-CERA C	CK725B1A-105K0	1	332001055R1
C8911	C-CERA C	CK725B1C-104K0	1	332011045R1
C8912	C-CERA C	CK725B0J-226M	1	332092267R2
C8913	C-CERA C	CK725B0J-226M	1	332092267R2
C8914	C-CERA C	CK725B1C-104K0	1	332011045R1
C8915	C-CERA C	CK725B0J-226M	1	332092267R2
C8916	C-CERA C	CK725B0J-226M	1	332092267R2
C8917	C-CERA C	CK725B1C-104K0	1	332011045R1
C8918	C-CERA C	CK725B0J-226M	1	332092267R2
C8919	C-CERA C	CK725B0J-226M	1	332092267R2
C8920	C-CERA C	CK725B1C-104K0	1	332011045R1
C8921	C-CERA C	CK725B0J-226M	1	332092267R2
C8922	C-CERA C	CK725B0J-226M	1	332092267R2
C8931	C-CERA C	CK725B1H-103K0	1	332031035R1
C8932	C-CERA C	CK725B1C-104K0	1	332011045R1
C8933	C-CERA C	CK725B1E-106K	1	332221065R2
C8934	C-CERA C	CK725B1E-106K	1	332221065R2
C8935	C-CERA C	CK725B1H-103K0	1	332031035R1
C8936	C-CERA C	CK725B0J-226M	1	332092267R2
C8937	C-CERA C	CK725B0J-226M	1	332092267R2
C8941	C-CERA C	CK725B1H-103K0	1	332031035R1
C8942	C-CERA C	CK725B1C-104K0	1	332011045R1
C8943	C-CERA C	CK725B1E-106K	1	332221065R2
C8944	C-CERA C	CK725B1E-106K	1	332221065R2
C8945	C-CERA C	CK725B1H-103K0	1	332031035R1
C8946	C-CERA C	CK725B0J-226M	1	332092267R2
C8947	C-CERA C	CK725B0J-226M	1	332092267R2
C8951	C-CERA C	CK725B1H-103K0	1	332031035R1
C8952	C-CERA C	CK725B1C-104K0	1	332011045R1
C8953	C-CERA C	CK725B1E-106K	1	332221065R2
C8954	C-CERA C	CK725B1E-106K	1	332221065R2
C8955	C-CERA C	CK725B1H-103K0	1	332031035R1

C8956	C-CERA C	CK725B0J-226M	1	332092267R2
C8957	C-CERA C	CK725B0J-226M	1	332092267R2
C8961	C-CERA C	CK725B1H-103K0	1	332031035R1
C8962	C-CERA C	CK725B1C-104K0	1	332011045R1
C8963	C-CERA C	CK725B1E-106K	1	332221065R2
C8964	C-CERA C	CK725B1E-106K	1	332221065R2
C8965	C-CERA C	CK725B1H-103K0	1	332031035R1
C8966	C-CERA C	CK725B0J-226M	1	332092267R2
C8967	C-CERA C	CK725B0J-226M	1	332092267R2
C8971	C-CERA C	CK732B16V-106K	1	332071065R2
C8980	C-CERA C	CK725B1A-105K0	1	332001055R1
C8981	C-CERA C	CK732B16V-106K	1	332071065R2
C8982	C-CERA C	CK725B1A-105K0	1	332001055R1
C8983	C-CERA C	CK732B16V-106K	1	332071065R2
C8984	C-CERA C	CK725B1A-105K0	1	332001055R1
C8985	C-CERA C	CK732B16V-106K	1	332071065R2
[RESISTOR]				
R1001	C-CARBON R	RN72K1J-151JE	1	435031514R1
R1002	C-CARBON R	RN72K1J-151JE	1	435031514R1
R1003	C-CARBON R	RN72K1J-151JE	1	435031514R1
R1004	C-CARBON R	RN72K1J-151JE	1	435031514R1
R1005	C-CARBON R	RN72K1J-331JE	1	435033314R1
R1006	C-CARBON R	RN72K1J-560JE	1	435035604R1
R1007	C-CARBON R	RN72K1J-105JE	1	435031054R1
R1008	C-CARBON R	RN72K1J-102JE	1	435031024R1
R1009	C-CARBON R	RN72K1J-181JE	1	435031814R1
R1010	C-CARBON R	RN72K1J-103JE	1	435031034R1
R1011	C-CARBON R	RN72K1J-220JE	1	435032204R1
R1012	C-CARBON R	RN72K1J-220JE	1	435032204R1
R1013	C-CARBON R	RN72K1J-220JE	1	435032204R1
R1014	C-CARBON R	RN72K1J-220JE	1	435032204R1
R1015	C-CARBON R	RN72K1J-220JE	1	435032204R1
R1016	C-CARBON R	RN72K1J-220JE	1	435032204R1
R1017	C-CARBON R	RN72K1J-470JE	1	435034704R1
R1019	C-CARBON R	RN72K1J-470JE	1	435034704R1
R1020	C-CARBON R	RN72K1J-391JE	1	435033914R1
R1021	C-CARBON R	RN72K1J-101JE	1	435031014R1
R1022	C-CARBON R	RN72K1J-151JE	1	435031514R1
R1023	C-CARBON R	RN72K1J-221JE	1	435032214R1
R1024	C-CARBON R	RN72K1J-470JE	1	435034704R1
R1025	C-CARBON R	RN72K1J-470JE	1	435034704R1
R1026	C-CARBON R	RN72K1J-331JE	1	435033314R1
R1027	C-R NET	RM7LJ221X04	1	43484722104R2
R1027 or	C-R NET	YCN104-221-JK	(1)	43464C22104R1
R1028	C-CARBON R	RN72K1J-472JE	1	435034724R1
R1029	C-CARBON R	RN72K1J-102JE	1	435031024R1
R1031	C-CARBON R	RN72K1J-331JE	1	435033314R1
R1032	C-CARBON R	RN72K1J-331JE	1	435033314R1
R1033	C-CARBON R	RN72K1J-221JE	1	435032214R1
R1034	C-CARBON R	RN72K1J-472JE	1	435034724R1
R1035	C-CARBON R	RN72K1J-331JE	1	435033314R1
R1036	C-CARBON R	RN72K1J-331JE	1	435033314R1
R1037	C-CARBON R	RN72K1J-331JE	1	435033314R1
R1038	C-CARBON R	RN72K1J-331JE	1	435033314R1
R1039	C-CARBON R	RN72K1J-330JE	1	435033304R1
R1040	C-CARBON R	RN72K1J-331JE	1	435033314R1
R1041	C-CARBON R	RN72K1J-221JE	1	435032214R1
R1042	C-CARBON R	RN72K1J-331JE	1	435033314R1
R1043	C-CARBON R	RN72K1J-221JE	1	435032214R1
R1044	C-CARBON R	RN72K1J-221JE	1	435032214R1
R1045	C-CARBON R	RN72K1J-221JE	1	435032214R1
R1046	C-CARBON R	RN72K1J-470JE	1	435034704R1
R1047	C-CARBON R	RN72K1J-681JE	1	435036814R1
R1048	C-CARBON R	RN72K1J-331JE	1	435033314R1
R1049	C-CARBON R	RN72K1J-331JE	1	435033314R1
R1054	C-CARBON R	RN72K1J-000JE	1	435030004R1
R1055	C-CARBON R	RN72K1J-000JE	1	435030004R1
R1060	C-CARBON R	RN72K1J-470JE	1	435034704R1
R1076	C-CARBON R	RN72K1J-000JE	1	435030004R1
R1077	C-CARBON R	RN72K1J-000JE	1	435030004R1
R1091	C-CARBON R	RN72K1J-000JE	1	435030004R1
R1092	C-CARBON R	RN72K1J-000JE	1	435030004R1
R1093	C-CARBON R	RN72K1J-000JE	1	435030004R1
R1094	C-CARBON R	RN72K1J-000JE	1	435030004R1
R3007	C-CARBON R	RN72K1J-470JE	1	435034704R1
R3009	C-CARBON R	RN72K1J-330JE	1	435033304R1

R3010	C-R NET	RM7LJ330X04	1	43484733004R2
R3010 or	C-R NET	YCN104-330-JK	(1)	43464C33004R1
R3011	C-R NET	RM7LJ330X04	1	43484733004R2
R3011 or	C-R NET	YCN104-330-JK	(1)	43464C33004R1
R3012	C-R NET	RM7LJ470X04	1	43484747004R2
R3012 or	C-R NET	YCN104-470-JK	(1)	43464C47004R1
R3013	C-R NET	RM7LJ330X04	1	43484733004R2
R3013 or	C-R NET	YCN104-330-JK	(1)	43464C33004R1
R3014	C-R NET	RM7LJ330X04	1	43484733004R2
R3014 or	C-R NET	YCN104-330-JK	(1)	43464C33004R1
R3015	C-R NET	RM7LJ330X04	1	43484733004R2
R3015 or	C-R NET	YCN104-330-JK	(1)	43464C33004R1
R3016	C-CARBON R	RN72K1J-470JE	1	435034704R1
R3017	C-R NET	RM7LJ330X04	1	43484733004R2
R3017 or	C-R NET	YCN104-330-JK	(1)	43464C33004R1
R3018	C-CARBON R	RN72K1J-470JE	1	435034704R1
R3019	C-R NET	RM7LJ330X04	1	43484733004R2
R3019 or	C-R NET	YCN104-330-JK	(1)	43464C33004R1
R3020	C-R NET	RM7LJ330X04	1	43484733004R2
R3020 or	C-R NET	YCN104-330-JK	(1)	43464C33004R1
R3021	C-CARBON R	RN72K1J-470JE	1	435034704R1
R3022	C-CARBON R	RN72K1J-470JE	1	435034704R1
R3023	C-R NET	RM7LJ470X04	1	43484747004R2
R3023 or	C-R NET	YCN104-470-JK	(1)	43464C47004R1
R3024	C-CARBON R	RN72K1J-470JE	1	435034704R1
R3025	C-CARBON R	RN72K1J-102JE	1	435031024R1
R3028	C-CARBON R	RN72K1J-470JE	1	435034704R1
R3029	C-CARBON R	RN72K1J-102JE	1	435031024R1
R3032	C-CARBON R	RN72K1J-103JE	1	435031034R1
R3033	C-CARBON R	RN72K1J-470JE	1	435034704R1
R3034	C-CARBON R	RN72K1J-470JE	1	435034704R1
R3035	C-CARBON R	RN72K1J-470JE	1	435034704R1
R3036	C-CARBON R	RN72K1J-470JE	1	435034704R1
R3037	C-CARBON R	RN72K1J-470JE	1	435034704R1
R3038	C-CARBON R	RN72K1J-470JE	1	435034704R1
R3039	C-CARBON R	RN72K1J-470JE	1	435034704R1
R3040	C-CARBON R	RN72K1J-103JE	1	435031034R1
R3041	C-R NET	RM7LJ330X04	1	43484733004R2
R3041 or	C-R NET	YCN104-330-JK	(1)	43464C33004R1
R3042	C-R NET	RM7LJ330X04	1	43484733004R2
R3042 or	C-R NET	YCN104-330-JK	(1)	43464C33004R1
R3043	C-CARBON R	RN72K1J-000JE	1	435030004R1
R3044	C-R NET	RM7LJ330X04	1	43484733004R2
R3044 or	C-R NET	YCN104-330-JK	(1)	43464C33004R1
R3045	C-R NET	RM7LJ330X04	1	43484733004R2
R3045 or	C-R NET	YCN104-330-JK	(1)	43464C33004R1
R3047	C-CARBON R	RN72K1J-560JE	1	435035604R1
R3048	C-CARBON R	RN72K1J-221JE	1	435032214R1
R3049	C-CARBON R	RN72K1J-560JE	1	435035604R1
R3050	C-CARBON R	RN72K1J-560JE	1	435035604R1
R3051	C-CARBON R	RN72K1J-560JE	1	435035604R1
R3054	C-CARBON R	RN72K1J-103JE	1	435031034R1
R3056	C-CARBON R	RN72K1J-472JE	1	435034724R1
R3060	C-CARBON R	RN72K1J-680JE	1	435036804R1
R3061	C-CARBON R	RN72K1J-470JE	1	435034704R1
R3062	C-CARBON R	RN72K1J-680JE	1	435036804R1
R3063	C-CARBON R	RN72K1J-680JE	1	435036804R1
R3064	C-CARBON R	RN72K1J-680JE	1	435036804R1
R3065	C-CARBON R	RN72K1J-680JE	1	435036804R1
R3066	C-CARBON R	RN72K1J-102JE	1	435031024R1
R3071	C-CARBON R	RN72K1J-000JE	1	435030004R1
R3108	C-CARBON R	RN72K1J-103JE	1	435031034R1
R3110	C-CARBON R	RN72K1J-103JE	1	435031034R1
R3111	C-CARBON R	RN72K1J-103JE	1	435031034R1
R3113	C-CARBON R	RN72K1J-103JE	1	435031034R1
R3115	C-CARBON R	RN72K1J-332JE	1	435033324R1
R3117	C-CARBON R	RN72K1J-332JE	1	435033324R1
R3119	C-CARBON R	RN72K1J-332JE	1	435033324R1
R3122	C-CARBON R	RN72K1J-102JE	1	435031024R1
R3124	C-CARBON R	RN72K1J-331JE	1	435033314R1
R3125	C-CARBON R	RN72K1J-470JE	1	435034704R1
R3126	C-CARBON R	RN72K1J-470JE	1	435034704R1
R3127	C-CARBON R	RN72K1J-470JE	1	435034704R1
R3128	C-CARBON R	RN72K1J-472JE	1	435034724R1
R3129	C-CARBON R	RN72K1J-470JE	1	435034704R1
R3130	C-CARBON R	RN72K1J-470JE	1	435034704R1

R3131	C-CARBON R	RN72K1J-470JE	1	435034704R1
R3132	C-CARBON R	RN72K1J-103JE	1	435031034R1
R3133	C-CARBON R	RN72K1J-470JE	1	435034704R1
R3134	C-CARBON R	RN72K1J-103JE	1	435031034R1
R3135	C-CARBON R	RN72K1J-103JE	1	435031034R1
R3136	C-CARBON R	RN72K1J-000JE	1	435030004R1
R3137	C-CARBON R	RN72K1J-000JE	1	435030004R1
R3138	C-CARBON R	RN72K1J-102JE	1	435031024R1
R3139	C-CARBON R	RN72K1J-101JE	1	435031014R1
R3141	C-CARBON R	RN72K1J-000JE	1	435030004R1
R3143	C-CARBON R	RN72K1J-392JE	1	43503924R1
R3144	C-CARBON R	RN72K1J-101JE	1	435031014R1
R3145	C-CARBON R	RN72K1J-392JE	1	43503924R1
R3146	C-CARBON R	RN72K1J-390JE	1	43503904R1
R3147	C-CARBON R	RN72K1J-000JE	1	435030004R1
R3148	C-CARBON R	RN72K1J-390JE	1	43503904R1
R3149	C-CARBON R	RN72K1J-102JE	1	435031024R1
R3150	C-CARBON R	RN72K1J-680JE	1	435036804R1
R3151	C-CARBON R	RN72K1J-000JE	1	435030004R1
R3152	C-CARBON R	RN72K1J-000JE	1	435030004R1
R3154	C-CARBON R	RN72K1J-390JE	1	43503904R1
R3155	C-CARBON R	RN72K1J-390JE	1	43503904R1
R3156	C-CARBON R	RN72K1J-390JE	1	43503904R1
R3157	C-CARBON R	RN72K1J-000JE	1	435030004R1
R3162	C-CARBON R	RN72K1J-390JE	1	43503904R1
R3163	C-CARBON R	RN72K1J-220JE	1	435032204R1
R3164	C-CARBON R	RN72K1J-472JE	1	435034724R1
R3168	C-CARBON R	RN72K1J-220JE	1	435032204R1
R3169	C-CARBON R	RN72K1J-220JE	1	435032204R1
R3170	C-CARBON R	RN72K1J-391FE	1	43503912R1
R3171	C-CARBON R	RN72K1J-222FE	1	43503222R1
R3172	C-CARBON R	RN72K1J-392FE	1	43503922R1
R3173	C-CARBON R	RN72K1J-390JE	1	43503904R1
R3174	C-CARBON R	RN72K1J-390JE	1	43503904R1
R3175	C-CARBON R	RN72K1J-472JE	1	435034724R1
R3176	C-CARBON R	RN72K1J-000JE	1	435030004R1
R3177	C-CARBON R	RN72K1J-222JE	1	43503222R1
R3181	C-CARBON R	RN72K1J-470JE	1	435034704R1
R3182	C-CARBON R	RN72K1J-472JE	1	435034724R1
R3183	C-CARBON R	RN72K1J-470JE	1	435034704R1
R3184	C-CARBON R	RN72K1J-470JE	1	435034704R1
R3187	C-CARBON R	RN72K1J-472JE	1	435034724R1
R3188	C-CARBON R	RN72K1J-103JE	1	435031034R1
R3190	C-CARBON R	RN72K1J-103JE	1	435031034R1
R3192	C-CARBON R	RN72K1J-472JE	1	435034724R1
R3193	C-CARBON R	RN72K1J-472JE	1	435034724R1
R3194	C-CARBON R	RN72K1J-472JE	1	435034724R1
R3199	C-CARBON R	RN72K1J-102JE	1	435031024R1
R3204	C-CARBON R	RN72K1J-103JE	1	435031034R1
R3205	C-CARBON R	RN72K1J-103JE	1	435031034R1
R3208	C-CARBON R	RN72K1J-271JE	1	435032714R1
R3212	C-CARBON R	RN72K1J-220JE	1	435032204R1
R3215	C-CARBON R	RN72K1J-221JE	1	435032214R1
R3218	C-CARBON R	RN72K1J-220JE	1	435032204R1
R3219	C-CARBON R	RN72K1J-221JE	1	435032214R1
R3226	C-R NET	RM7LJ470X04	1	43484747004R2
R3226 or	C-R NET	YCN104-470-JK	(1)	43464C47004R1
R3230	C-CARBON R	RN72K1J-221JE	1	435032214R1
R3234	C-CARBON R	RN72K1J-470JE	1	435034704R1
R3237	C-CARBON R	RN72K1J-221JE	1	435032214R1
R3238	C-CARBON R	RN72K1J-470JE	1	435034704R1
R3239	C-CARBON R	RN72K1J-221JE	1	435032214R1
R3240	C-CARBON R	RN72K1J-221JE	1	435032214R1
R3241	C-CARBON R	RN72K1J-221JE	1	435032214R1
R3242	C-CARBON R	RN72K1J-221JE	1	435032214R1
R3244	C-CARBON R	RN72K1J-470JE	1	435034704R1
R3247	C-CARBON R	RN72K1J-121JE	1	435031214R1
R3251	C-CARBON R	RN72K1J-470JE	1	435034704R1
R3257	C-CARBON R	RN72K1J-470JE	1	435034704R1
R3260	C-CARBON R	RN72K1J-390JE	1	43503904R1
R3262	C-CARBON R	RN72K1J-221JE	1	435032214R1
R3265	C-CARBON R	RN72K1J-390JE	1	43503904R1
R3266	C-CARBON R	RN72K1J-332JE	1	435033324R1
R3268	C-CARBON R	RN72K1J-390JE	1	43503904R1
R3271	C-CARBON R	RN72K1J-390JE	1	43503904R1
R3272	C-CARBON R	RN72K1J-470JE	1	435034704R1

R3274	C-CARBON R	RN72K1J-390JE	1	435033904R1
R3277	C-CARBON R	RN72K1J-220JE	1	435032204R1
R3280	C-CARBON R	RN72K1J-470JE	1	435034704R1
R3281	C-CARBON R	RN72K1J-103JE	1	435031034R1
R3283	C-CARBON R	RN72K1J-470JE	1	435034704R1
R3284	C-CARBON R	RN72K1J-103JE	1	435031034R1
R3285	C-CARBON R	RN72K1J-332JE	1	435033324R1
R3286	C-CARBON R	RN72K1J-332JE	1	435033324R1
R3290	C-R NET	RM7LJ470X04	1	43484747004R2
R3290 or	C-R NET	YCN104-470-JK	(1)	43464C47004R1
R3291	C-R NET	RM7LJ470X04	1	43484747004R2
R3291 or	C-R NET	YCN104-470-JK	(1)	43464C47004R1
R3292	C-R NET	RM7LJ470X04	1	43484747004R2
R3292 or	C-R NET	YCN104-470-JK	(1)	43464C47004R1
R3293	C-R NET	RM7LJ470X04	1	43484747004R2
R3293 or	C-R NET	YCN104-470-JK	(1)	43464C47004R1
R3294	C-R NET	RM7LJ470X04	1	43484747004R2
R3294 or	C-R NET	YCN104-470-JK	(1)	43464C47004R1
R3295	C-R NET	RM7LJ470X04	1	43484747004R2
R3295 or	C-R NET	YCN104-470-JK	(1)	43464C47004R1
R3296	C-CARBON R	RN72K1J-470JE	1	435034704R1
R3297	C-CARBON R	RN72K1J-470JE	1	435034704R1
R3298	C-CARBON R	RN72K1J-102JE	1	435031024R1
R3300	C-CARBON R	RN72K1J-102JE	1	435031024R1
R7002	C-CARBON R	RN72K1J-103JE	1	435031034R1
R7003	C-CARBON R	RN72K1J-103JE	1	435031034R1
R7004	C-CARBON R	RN72K1J-273JE	1	435032734R1
R7005	C-CARBON R	RN72K1J-223JE	1	435032234R1
R7006	C-CARBON R	RN72K1J-223JE	1	435032234R1
R7007	C-CARBON R	RN72K1J-105JE	1	435031054R1
R7008	C-CARBON R	RN72K1J-473JE	1	435034734R1
R7009	C-CARBON R	RN72K1J-105JE	1	435031054R1
R7010	C-CARBON R	RN72K1J-103JE	1	435031034R1
R7011	C-CARBON R	RN72K1J-103JE	1	435031034R1
R7012	C-CARBON R	RN72K1J-103JE	1	435031034R1
R7013	C-CARBON R	RN72K1J-103JE	1	435031034R1
R7014	C-CARBON R	RN72K1J-473JE	1	435034734R1
R7015	C-CARBON R	RN72K1J-473JE	1	435034734R1
R7016	C-CARBON R	RN72K1J-473JE	1	435034734R1
R7017	C-CARBON R	RN72K1J-472JE	1	435034724R1
R7018	C-CARBON R	RN72K1J-472JE	1	435034724R1
R7019	C-CARBON R	RN72K1J-472JE	1	435034724R1
R7020	C-CARBON R	RN72K1J-472JE	1	435034724R1
R7021	C-R NET	RM7LJ221X04	1	43484722104R2
R7021 or	C-R NET	YCN104-221-JK	(1)	43464C22104R1
R7023	C-CARBON R	RN72K1J-221JE	1	435032214R1
R7024	C-CARBON R	RN72K1J-103JE	1	435031034R1
R7025	C-CARBON R	RN72K1J-224JE	1	435032244R1
R7026	C-CARBON R	RN72K1J-224JE	1	435032244R1
R7027	C-CARBON R	RN72K1J-103JE	1	435031034R1
R7028	C-CARBON R	RN72K1J-000JE	1	435030004R1
R7029	C-CARBON R	RN72K1J-102JE	1	435031024R1
R7030	C-CARBON R	RN72K1J-221JE	1	435032214R1
R7031	C-R NET	RM7LJ221X04	1	43484722104R2
R7031 or	C-R NET	YCN104-221-JK	(1)	43464C22104R1
R7032	C-CARBON R	RN72K1J-221JE	1	435032214R1
R7033	C-R NET	RM7LJ470X04	1	43484747004R2
R7033 or	C-R NET	YCN104-470-JK	(1)	43464C47004R1
R7034	C-CARBON R	RN72K1J-221JE	1	435032214R1
R7035	C-CARBON R	RN72K1J-470JE	1	435034704R1
R7036	C-CARBON R	RN72K1J-102JE	1	435031024R1
R7037	C-CARBON R	RN72K1J-102JE	1	435031024R1
R7038	C-CARBON R	RN72K1J-102JE	1	435031024R1
R7039	C-CARBON R	RN72K1J-222JE	1	435032224R1
R7040	C-CARBON R	RN72K1J-222JE	1	435032224R1
R7041	C-CARBON R	RN72K1J-222JE	1	435032224R1
R7042	C-CARBON R	RN72K1J-221JE	1	435032214R1
R7043	C-CARBON R	RN72K1J-103JE	1	435031034R1
R7044	C-CARBON R	RN72K1J-470JE	1	435034704R1
R7045	C-CARBON R	RN72K1J-103JE	1	435031034R1
R7046	C-CARBON R	RN72K1J-221JE	1	435032214R1
R7047	C-CARBON R	RN72K1J-103JE	1	435031034R1
R7048	C-CARBON R	RN72K1J-221JE	1	435032214R1
R7049	C-CARBON R	RN72K1J-470JE	1	435034704R1
R7050	C-CARBON R	RN72K1J-103JE	1	435031034R1
R7051	C-CARBON R	RN72K1J-221JE	1	435032214R1

R7052	C-CARBON R	RN72K1J-221JE	1	435032214R1
R7053	C-CARBON R	RN72K1J-221JE	1	435032214R1
R7054	C-CARBON R	RN72K1J-102JE	1	435031024R1
R7055	C-CARBON R	RN72K1J-102JE	1	435031024R1
R7057	C-CARBON R	RN72K1J-103JE	1	435031034R1
R7058	C-CARBON R	RN72K1J-103JE	1	435031034R1
R7059	C-CARBON R	RN72K1J-103JE	1	435031034R1
R7061	C-CARBON R	RN72K1J-221JE	1	435032214R1
R7062	C-CARBON R	RN72K1J-221JE	1	435032214R1
R7063	C-CARBON R	RN72K1J-103JE	1	435031034R1
R7064	C-CARBON R	RN72K1J-470JE	1	435034704R1
R7065	C-CARBON R	RN72K1J-473JE	1	435034734R1
R7066	C-CARBON R	RN72K1J-221JE	1	435032214R1
R7067	C-CARBON R	RN72K1J-000JE	1	435030004R1
R7068	C-CARBON R	RN72K1J-000JE	1	435030004R1
R7069	C-R NET	RM7LJ470X04	1	43484747004R2
R7069 or	C-R NET	YCN104-470-JK	(1)	43464C47004R1
R7070	C-CARBON R	RN72K1J-470JE	1	435034704R1
R7071	C-CARBON R	RN72K1J-103JE	1	435031034R1
R7072	C-CARBON R	RN72K1J-470JE	1	435034704R1
R7075	C-R NET	RM7LJ470X04	1	43484747004R2
R7075 or	C-R NET	YCN104-470-JK	(1)	43464C47004R1
R7076	C-CARBON R	RN72K1J-221JE	1	435032214R1
R7078	C-CARBON R	RN72K1J-103JE	1	435031034R1
R7079	C-R NET	RM7LJ221X04	1	43484722104R2
R7079 or	C-R NET	YCN104-221-JK	(1)	43464C22104R1
R7081	C-CARBON R	RN72K1J-221JE	1	435032214R1
R7082	C-R NET	RM7LJ470X04	1	43484747004R2
R7082 or	C-R NET	YCN104-470-JK	(1)	43464C47004R1
R7083	C-CARBON R	RN72K1J-103JE	1	435031034R1
R7084	C-CARBON R	RN72K1J-470JE	1	435034704R1
R7085	C-CARBON R	RN72K1J-102JE	1	435031024R1
R7087	C-CARBON R	RN72K1J-273JE	1	435032734R1
R7091	C-CARBON R	RN72K1J-221JE	1	435032214R1
R7092	C-CARBON R	RN72K1J-470JE	1	435034704R1
R7093	C-CARBON R	RN72K1J-472JE	1	435034724R1
R7094	C-CARBON R	RN72K1J-472JE	1	435034724R1
R7095	C-R NET	RM7LJ221X04	1	43484722104R2
R7095 or	C-R NET	YCN104-221-JK	(1)	43464C22104R1
R7096	C-CARBON R	RN72K1J-221JE	1	435032214R1
R7097	C-CARBON R	RN72K1J-470JE	1	435034704R1
R7098	C-R NET	RM7LJ470X04	1	43484747004R2
R7098 or	C-R NET	YCN104-470-JK	(1)	43464C47004R1
R7099	C-R NET	RM7LJ470X04	1	43484747004R2
R7099 or	C-R NET	YCN104-470-JK	(1)	43464C47004R1
R7100	C-CARBON R	RN72K1J-000JE	1	435030004R1
R7101	C-CARBON R	RN72K1J-102JE	1	435031024R1
R7102	C-CARBON R	RN72K1J-103FE	1	435031032R1
R7103	C-CARBON R	RN72K1J-221JE	1	435032214R1
R7104	C-CARBON R	RN72K1J-470JE	1	435034704R1
R7105	C-R NET	RM7LJ470X04	1	43484747004R2
R7105 or	C-R NET	YCN104-470-JK	(1)	43464C47004R1
R7106	C-CARBON R	RN72K1J-101JE	1	435031014R1
R7107	C-CARBON R	RN72K1J-101JE	1	435031014R1
R7108	C-R NET	RM7LJ223X04	1	43484722304R2
R7108 or	C-R NET	YCN104-223-JK	(1)	43464C22304R1
R7109	C-CARBON R	RN72K1J-103JE	1	435031034R1
R7110	C-CARBON R	RN72K1J-103JE	1	435031034R1
R7111	C-CARBON R	RN72K1J-103JE	1	435031034R1
R7112	C-CARBON R	RN72K1J-101JE	1	435031014R1
R7113	C-CARBON R	RN72K1J-470JE	1	435034704R1
R7114	C-CARBON R	RN72K1J-470JE	1	435034704R1
R7115	C-CARBON R	RN72K1J-103JE	1	435031034R1
R7116	C-CARBON R	RN72K1J-103JE	1	435031034R1
R7117	C-CARBON R	RN72K1J-273JE	1	435032734R1
R7118	C-CARBON R	RN72K1J-103JE	1	435031034R1
R7120	C-CARBON R	RN72K1J-103JE	1	435031034R1
R7121	C-CARBON R	RN72K1J-105JE	1	435031054R1
R7122	C-CARBON R	RN72K1J-105JE	1	435031054R1
R7123	C-R NET	RM7LJ221X04	1	43484722104R2
R7123 or	C-R NET	YCN104-221-JK	(1)	43464C22104R1
R7124	C-CARBON R	RN72K1J-223JE	1	435032234R1
R7125	C-CARBON R	RN72K1J-473JE	1	435034734R1
R7126	C-CARBON R	RN72K1J-221JE	1	435032214R1
R7131	C-CARBON R	RN72K1J-470JE	1	435034704R1
R7132	C-CARBON R	RN72K1J-470JE	1	435034704R1

R7133	C-CARBON R	RN72K1J-221JE	1	435032214R1
R7134	C-CARBON R	RN72K1J-221JE	1	435032214R1
R7135	C-CARBON R	RN72K1J-103JE	1	435031034R1
R7136	C-CARBON R	RN72K1J-470JE	1	435034704R1
R7137	C-CARBON R	RN72K1J-470JE	1	435034704R1
R7138	C-CARBON R	RN72K1J-470JE	1	435034704R1
R7139	C-CARBON R	RN72K1J-103JE	1	435031034R1
R7140	C-CARBON R	RN72K1J-103JE	1	435031034R1
R7141	C-CARBON R	RN72K1J-103JE	1	435031034R1
R7150	C-CARBON R	RN72K1J-221JE	1	435032214R1
R7151	C-CARBON R	RN72K1J-221JE	1	435032214R1
R7152	C-CARBON R	RN72K1J-103JE	1	435031034R1
R7153	C-CARBON R	RN72K1J-103JE	1	435031034R1
R7155	C-R NET	RM7LJ103X04	1	43484710304R2
R7155 or	C-R NET	YCN104-103-JK	(1)	43464C10304R1
R7160	C-CARBON R	RN72K1J-473JE	1	435034734R1
R7161	C-CARBON R	RN72K1J-103JE	1	435031034R1
R7162	C-CARBON R	RN72K1J-103JE	1	435031034R1
R7170	C-CARBON R	RN72K1J-102JE	1	435031024R1
R7171	C-CARBON R	RN72K1J-473JE	1	435034734R1
R7172	C-CARBON R	RN72K1J-222JE	1	435032224R1
R7180	C-CARBON R	RN72K1J-000JE	1	435030004R1
R7301	C-CARBON R	RN72K1J-272JE	1	435032724R1
R7302	C-CARBON R	RN72K1J-272JE	1	435032724R1
R7303	C-CARBON R	RN72K1J-272JE	1	435032724R1
R7304	C-CARBON R	RN72K1J-272JE	1	435032724R1
R7310	C-CARBON R	RN72K1J-103JE	1	435031034R1
R7313	C-CARBON R	RN72K1J-102JE	1	435031024R1
R8001	C-CARBON R	RN72K1J-103JE	1	435031034R1
R8003	C-CARBON R	RN72K1J-000JE	1	435030004R1
R8004	C-CARBON R	RN72K1J-103JE	1	435031034R1
R8005	C-CARBON R	RN72K1J-103JE	1	435031034R1
R8006	C-CARBON R	RN72K1J-103FE	1	435031032R1
R8007	C-CARBON R	RN72K1J-472JE	1	435034724R1
R8009	C-CARBON R	RN72K1J-000JE	1	435030004R1
R8010	C-R NET	RM7LJ510X04	1	43484751004R2
R8010 or	C-R NET	YCN104-510-JK	(1)	43464C51004R1
R8011	C-R NET	RM7LJ510X04	1	43484751004R2
R8011 or	C-R NET	YCN104-510-JK	(1)	43464C51004R1
R8012	C-R NET	RM7LJ510X04	1	43484751004R2
R8012 or	C-R NET	YCN104-510-JK	(1)	43464C51004R1
R8013	C-R NET	RM7LJ510X04	1	43484751004R2
R8013 or	C-R NET	YCN104-510-JK	(1)	43464C51004R1
R8014	C-R NET	RM7LJ510X04	1	43484751004R2
R8014 or	C-R NET	YCN104-510-JK	(1)	43464C51004R1
R8015	C-CARBON R	MCR03EZPF49R9(49.9_1%)	1	4100037R2
R8015 or	CARBON R	CR16-49R9-FL	(1)	4100046R1
R8016	C-CARBON R	MCR03EZPF49R9(49.9_1%)	1	4100037R2
R8016 or	CARBON R	CR16-49R9-FL	(1)	4100046R1
R8017	C-CARBON R	MCR03EZPF49R9(49.9_1%)	1	4100037R2
R8017 or	CARBON R	CR16-49R9-FL	(1)	4100046R1
R8018	C-CARBON R	RN72K1J-000JE	1	435030004R1
R8019	C-CARBON R	RN72K1J-000JE	1	435030004R1
R8020	C-CARBON R	RN72K1J-472JE	1	435034724R1
R8021	C-CARBON R	RN72K1J-000JE	1	435030004R1
R8022	C-CARBON R	RN72K1J-000JE	1	435030004R1
R8023	C-CARBON R	RN72K1J-000JE	1	435030004R1
R8037	C-CARBON R	RN72K1J-000JE	1	435030004R1
R8042	C-CARBON R	MCR03EZPF49R9(49.9_1%)	1	4100037R2
R8042 or	CARBON R	CR16-49R9-FL	(1)	4100046R1
R8043	C-CARBON R	MCR03EZPF49R9(49.9_1%)	1	4100037R2
R8043 or	CARBON R	CR16-49R9-FL	(1)	4100046R1
R8045	C-CARBON R	RN72K1J-331FE	1	435033312R1
R8046	C-CARBON R	RN72K1J-332FE	1	435033322R1
R8047	C-CARBON R	RN72K1J-271FE	1	435032712R1
R8048	C-CARBON R	RN72K1J-222FE	1	435032222R1
R8049	C-CARBON R	RN72K1J-750JE	1	435037504R1
R8050	C-CARBON R	RN72K1J-750JE	1	435037504R1
R8052	C-CARBON R	RN72K1J-472JE	1	435034724R1
R8073	C-CARBON R	RN72K1J-182JE	1	435031824R1
R8074	C-CARBON R	RN72K1J-182JE	1	435031824R1
R8077	C-CARBON R	RN72K1J-104JE	1	435031044R1
R8078	C-CARBON R	RN72K1J-472JE	1	435034724R1
R8079	C-CARBON R	RN72K1J-473JE	1	435034734R1
R8080	C-CARBON R	RN72K1J-101JE	1	435031014R1
R8081	C-CARBON R	RN72K1J-101JE	1	435031014R1

R8082	C-CARBON R	RN72K1J-101JE	1	435031014R1
R8083	C-CARBON R	RN72K1J-101JE	1	435031014R1
R8084	C-CARBON R	RN72K1J-100JE	1	435031004R1
R8085	C-CARBON R	RN72K1J-100JE	1	435031004R1
R8086	C-CARBON R	RN72K1J-100JE	1	435031004R1
R8087	C-CARBON R	RN72K1J-823JE	1	435038234R1
R8088	C-CARBON R	RN72K1J-103JE	1	435031034R1
R8089	C-CARBON R	RN72K1J-330JE	1	435033304R1
R8090	C-CARBON R	RN72K1J-103JE	1	435031034R1
R8091	C-CARBON R	RN72K1J-220JE	1	435032204R1
R8092	C-CARBON R	RN72K1J-220JE	1	435032204R1
R8093	C-CARBON R	RN72K1J-220JE	1	435032204R1
R8094	C-CARBON R	RN72K1J-472JE	1	435034724R1
R8095	C-CARBON R	RN72K1J-105JE	1	435031054R1
R8096	C-CARBON R	RN72K1J-101JE	1	435031014R1
R8097	C-CARBON R	RN72K1J-101JE	1	435031014R1
R8098	C-CARBON R	RN72K1J-220JE	1	435032204R1
R8099	C-CARBON R	RN72K1J-102JE	1	435031024R1
R8100	C-CARBON R	RN72K1J-102JE	1	435031024R1
R8102	C-CARBON R	RN72K1J-472JE	1	435034724R1
R8103	C-CARBON R	RN72K1J-472JE	1	435034724R1
R8104	C-CARBON R	RN72K1J-472JE	1	435034724R1
R8105	C-CARBON R	RN72K1J-472JE	1	435034724R1
R8107	C-CARBON R	RN72K1J-472JE	1	435034724R1
R8108	C-CARBON R	RN72K1J-472JE	1	435034724R1
R8109	C-CARBON R	RN72K1J-472JE	1	435034724R1
R8110	C-CARBON R	RN72K1J-472JE	1	435034724R1
R8111	C-CARBON R	RN72K1J-101JE	1	435031014R1
R8112	C-CARBON R	RN72K1J-101JE	1	435031014R1
R8113	C-CARBON R	RN72K1J-101JE	1	435031014R1
R8114	C-CARBON R	RN72K1J-101JE	1	435031014R1
R8115	C-CARBON R	RN72K1J-104JE	1	435031044R1
R8116	C-CARBON R	RN72K1J-000JE	1	435030004R1
R8117	C-CARBON R	RN72K1J-470JE	1	435034704R1
R8118	C-CARBON R	RN72K1J-470JE	1	435034704R1
R8120	C-CARBON R	RN72K1J-472JE	1	435034724R1
R8122	C-CARBON R	RN72K1J-220JE	1	435032204R1
R8123	C-CARBON R	RN72K1J-220JE	1	435032204R1
R8124	C-CARBON R	RN72K1J-220JE	1	435032204R1
R8125	C-CARBON R	RN72K1J-220JE	1	435032204R1
R8126	C-CARBON R	RN72K1J-472JE	1	435034724R1
R8127	C-CARBON R	RN72K1J-472JE	1	435034724R1
R8128	C-CARBON R	RN72K1J-103JE	1	435031034R1
R8129	C-CARBON R	RN72K1J-103JE	1	435031034R1
R8151	C-CARBON R	RN72K1J-331JE	1	435033314R1
R8153	C-CARBON R	RN72K1J-331JE	1	435033314R1
R8154	C-CARBON R	RN72K1J-470JE	1	435034704R1
R8156	C-CARBON R	RN72K1J-331JE	1	435033314R1
R8157	C-CARBON R	RN72K1J-470JE	1	435034704R1
R8159	C-CARBON R	RN72K1J-331JE	1	435033314R1
R8160	C-CARBON R	RN72K1J-470JE	1	435034704R1
R8201	C-CARBON R	RN72K1J-393JE	1	435033934R1
R8202	C-CARBON R	RN72K1J-102JE	1	435031024R1
R8203	C-CARBON R	RN72K1J-102JE	1	435031024R1
R8204	C-CARBON R	RN72K1J-330JE	1	435033304R1
R8206	C-CARBON R	RN72K1J-000JE	1	435030004R1
R8207	C-CARBON R	RN72K1J-000JE	1	435030004R1
R8208	C-CARBON R	RN72K1J-821JE	1	435038214R1
R8209	C-CARBON R	RN72K1J-472JE	1	435034724R1
R8213	C-CARBON R	RN72K1J-000JE	1	435030004R1
R8214	C-CARBON R	RN72K1J-000JE	1	435030004R1
R8215	C-CARBON R	RN72K1J-821JE	1	435038214R1
R8216	C-CARBON R	RN72K1J-000JE	1	435030004R1
R8217	C-CARBON R	RN72K1J-000JE	1	435030004R1
R8218	C-CARBON R	RN72K1J-821JE	1	435038214R1
R8219	C-R NET	RM7LJ330X04	1	43484733004R2
R8219 or	C-R NET	YCN104-330-JK	(1)	43464C33004R1
R8220	C-CARBON R	RN72K1J-680JE	1	435036804R1
R8221	C-CARBON R	RN72K1J-680JE	1	435036804R1
R8223	C-CARBON R	RN72K1J-560JE	1	435035604R1
R8224	C-CARBON R	RN72K1J-330JE	1	435033304R1
R8225	C-CARBON R	RN72K1J-221JE	1	435032214R1
R8226	C-CARBON R	RN72K1J-221JE	1	435032214R1
R8228	C-CARBON R	RN72K1J-221JE	1	435032214R1
R8229	C-CARBON R	RN72K1J-330JE	1	435033304R1
R8230	C-CARBON R	RN72K1J-101JE	1	435031014R1

R8231	C-CARBON R	RN72K1J-330JE	1	43503304R1
R8232	C-CARBON R	RN72K1J-102JE	1	435031024R1
R8233	C-CARBON R	RN72K1J-000JE	1	435030004R1
R8234	C-CARBON R	RN72K1J-393JE	1	435033934R1
R8235	C-CARBON R	RN72K1J-102JE	1	435031024R1
R8236	C-CARBON R	RN72K1J-330JE	1	43503304R1
R8237	C-CARBON R	RN72K1J-105JE	1	435031054R1
R8238	C-CARBON R	RN72K1J-331JE	1	435033314R1
R8239	C-CARBON R	RN72K1J-330JE	1	43503304R1
R8240	C-CARBON R	RN72K1J-681JE	1	435036814R1
R8241	C-CARBON R	RN72K1J-393JE	1	435033934R1
R8242	C-CARBON R	RN72K1J-102JE	1	435031024R1
R8243	C-CARBON R	RN72K1J-681JE	1	435036814R1
R8244	C-CARBON R	RN72K1J-330JE	1	43503304R1
R8245	C-CARBON R	RN72K1J-103JE	1	435031034R1
R8246	C-CARBON R	RN72K1J-330JE	1	43503304R1
R8247	C-CARBON R	RN72K1J-330JE	1	43503304R1
R8248	C-CARBON R	RN72K1J-100JE	1	435031004R1
R8249	C-CARBON R	RN72K1J-182JE	1	435031824R1
R8250	C-CARBON R	RN72K1J-103JE	1	435031034R1
R8251	C-CARBON R	RN72K1J-182JE	1	435031824R1
R8302	C-CARBON R	RN72K1J-103JE	1	435031034R1
R8303	C-CARBON R	RN72K1J-562JE	1	435035624R1
R8304	C-CARBON R	RN72K1J-472JE	1	435034724R1
R8305	C-CARBON R	RN72K1J-562JE	1	435035624R1
R8306	C-CARBON R	RN72K1J-562JE	1	435035624R1
R8307	C-CARBON R	RN72K1J-472JE	1	435034724R1
R8308	C-CARBON R	RN72K1J-562JE	1	435035624R1
R8309	C-CARBON R	RN72K1J-562JE	1	435035624R1
R8310	C-CARBON R	RN72K1J-562JE	1	435035624R1
R8311	C-CARBON R	RN72K1J-000JE	1	435030004R1
R8312	C-CARBON R	RN72K1J-100JE	1	435031004R1
R8313	C-CARBON R	RN72K1J-000JE	1	435030004R1
R8314	C-CARBON R	RN72K1J-000JE	1	435030004R1
R8315	C-CARBON R	RN72K1J-181JE	1	435031814R1
R8316	C-CARBON R	RN72K1J-181JE	1	435031814R1
R8317	C-CARBON R	RN72K1J-181JE	1	435031814R1
R8318	C-CARBON R	RN72K1J-181JE	1	435031814R1
R8319	C-CARBON R	RN72K1J-181JE	1	435031814R1
R8320	C-CARBON R	RN72K1J-181JE	1	435031814R1
R8321	C-CARBON R	RN72K1J-181JE	1	435031814R1
R8322	C-CARBON R	RN72K1J-181JE	1	435031814R1
R8323	C-CARBON R	RN72K1J-181JE	1	435031814R1
R8324	C-CARBON R	RN72K1J-181JE	1	435031814R1
R8325	C-CARBON R	RN72K1J-181JE	1	435031814R1
R8326	C-CARBON R	RN72K1J-181JE	1	435031814R1
R8327	C-CARBON R	RN72K1J-181JE	1	435031814R1
R8328	C-CARBON R	RN72K1J-181JE	1	435031814R1
R8329	C-CARBON R	RN72K1J-181JE	1	435031814R1
R8330	C-CARBON R	RN72K1J-220JE	1	435032204R1
R8331	C-CARBON R	RN72K1J-220JE	1	435032204R1
R8332	C-CARBON R	RN72K1J-220JE	1	435032204R1
R8333	C-CARBON R	RN72K1J-220JE	1	435032204R1
R8334	C-CARBON R	RN72K1J-473JE	1	435034734R1
R8335	C-CARBON R	RN72K1J-473JE	1	435034734R1
R8336	C-CARBON R	RN72K1J-473JE	1	435034734R1
R8337	C-CARBON R	RN72K1J-000JE	1	435030004R1
R8338	C-CARBON R	RN72K1J-000JE	1	435030004R1
R8339	C-CARBON R	RN72K1J-000JE	1	435030004R1
R8342	C-R NET	RM7LJ220X04	1	43484722004R2
R8342 or	C-R NET	YCN104-220-JK	(1)	43464C22004R1
R8343	C-R NET	RM7LJ220X04	1	43484722004R2
R8343 or	C-R NET	YCN104-220-JK	(1)	43464C22004R1
R8346	C-CARBON R	RN72K1J-220JE	1	435032204R1
R8347	C-CARBON R	RN72K1J-000JE	1	435030004R1
R8348	C-CARBON R	RN72K1J-000JE	1	435030004R1
R8349	C-CARBON R	RN72K1J-000JE	1	435030004R1
R8350	C-CARBON R	RN72K1J-100JE	1	435031004R1
R8351	C-CARBON R	RN72K1J-100JE	1	435031004R1
R8352	C-CARBON R	RN72K1J-100JE	1	435031004R1
R8353	C-CARBON R	RN72K1J-100JE	1	435031004R1
R8354	C-CARBON R	RN72K1J-100JE	1	435031004R1
R8355	C-CARBON R	RN72K1J-103JE	1	435031034R1
R8357	C-CARBON R	RN72K1J-101JE	1	435031014R1
R8358	C-CARBON R	RN72K1J-102JE	1	435031024R1
R8359	C-CARBON R	RN72K1J-124JE	1	435031244R1

R8360	C-CARBON R	RN72K1J-102JE	1	435031024R1
R8361	C-CARBON R	RN72K1J-000JE	1	435030004R1
R8387	C-CARBON R	RN72K1J-000JE	1	435030004R1
R8388	C-CARBON R	RN72K1J-182JE	1	435031824R1
R8389	C-CARBON R	RN72K1J-182JE	1	435031824R1
R8391	C-CARBON R	RN72K1J-473JE	1	435034734R1
R8393	C-R NET	RM7LJ000X04	1	43484700004R2
R8393 or	C-R NET	YCN104-000-ZK	(1)	43484C00004R1
R8394	C-R NET	RM7LJ000X04	1	43484700004R2
R8394 or	C-R NET	YCN104-000-ZK	(1)	43484C00004R1
R8395	C-R NET	RM7LJ051X04	1	43484705104R2
R8395 or	C-R NET	YCN104-5R1-JK	(1)	43484C05104R1
R8396	C-R NET	RM7LJ051X04	1	43484705104R2
R8396 or	C-R NET	YCN104-5R1-JK	(1)	43484C05104R1
R8502	C-CARBON R	RN72K1J-473JE	1	435034734R1
R8503	C-CARBON R	RN72K1J-154JE	1	435031544R1
R8504	C-CARBON R	RN72K1J-472JE	1	435034724R1
R8505	C-CARBON R	RN72K1J-154JE	1	435031544R1
R8507	C-CARBON R	RN72K1J-101JE	1	435031014R1
R8508	C-CARBON R	RN72K1J-153JE	1	435031534R1
R8510	C-CARBON R	RN72K1J-472JE	1	435034724R1
R8511	C-CARBON R	RN72K1J-473JE	1	435034734R1
R8512	C-CARBON R	RN72K1J-473JE	1	435034734R1
R8513	C-CARBON R	RN72K1J-101JE	1	435031014R1
R8600	C-CARBON R	RN72K1J-000JE	1	435030004R1
R8601	C-CARBON R	RN72K1J-472JE	1	435034724R1
R8602	C-CARBON R	RN72K1J-472JE	1	435034724R1
R8603	C-CARBON R	RN72K1J-000JE	1	435030004R1
R8605	C-CARBON R	RN72K1J-473JE	1	435034734R1
R8606	C-CARBON R	RN72K1J-100JE	1	435031004R1
R8607	C-CARBON R	RN72K1J-000JE	1	435030004R1
R8608	C-CARBON R	RN72K1J-000JE	1	435030004R1
R8610	C-CARBON R	RN72K1J-000JE	1	435030004R1
R8614	C-CARBON R	RN72K1J-473JE	1	435034734R1
R8618	C-CARBON R	RN72K1J-100JE	1	435031004R1
R8623	C-CARBON R	RN72K1J-473JE	1	435034734R1
R8624	C-CARBON R	RN72K1J-473JE	1	435034734R1
R8625	C-CARBON R	RN72K1J-000JE	1	435030004R1
R8628	C-CARBON R	RN72K1J-100JE	1	435031004R1
R8629	C-CARBON R	RN72K1J-473JE	1	435034734R1
R8630	C-CARBON R	RN72K1J-000JE	1	435030004R1
R8633	C-CARBON R	RN72K1J-473JE	1	435034734R1
R8634	C-CARBON R	RN72K1J-473JE	1	435034734R1
R8635	C-CARBON R	RN72K1J-473JE	1	435034734R1
R8636	C-CARBON R	RN72K1J-000JE	1	435030004R1
R8638	C-CARBON R	RN72K1J-100JE	1	435031004R1
R8643	C-CARBON R	RN72K1J-473JE	1	435034734R1
R8644	C-CARBON R	RN72K1J-473JE	1	435034734R1
R8648	C-CARBON R	RN72K1J-100JE	1	435031004R1
R8653	C-CARBON R	RN72K1J-473JE	1	435034734R1
R8654	C-CARBON R	RN72K1J-473JE	1	435034734R1
R8663	C-CARBON R	RN72K1J-473JE	1	435034734R1
R8664	C-CARBON R	RN72K1J-473JE	1	435034734R1
R8673	C-CARBON R	RN72K1J-473JE	1	435034734R1
R8674	C-CARBON R	RN72K1J-473JE	1	435034734R1
R8688	C-CARBON R	RN72K1J-103JE	1	435031034R1
R8701	C-CARBON R	RN72K1J-103JE	1	435031034R1
R8702	C-CARBON R	RN72K1J-000JE	1	435030004R1
R8703	C-CARBON R	RN72K1J-103JE	1	435031034R1
R8704	C-CARBON R	RN72K1J-103JE	1	435031034R1
R8705	C-CARBON R	RN72K1J-222JE	1	435032224R1
R8706	C-CARBON R	RN72K1J-103JE	1	435031034R1
R8707	C-CARBON R	RN72K1J-103JE	1	435031034R1
R8708	C-CARBON R	RN72K1J-222JE	1	435032224R1
R8709	C-CARBON R	RN72K1J-103JE	1	435031034R1
R8710	C-CARBON R	RN72K1J-222JE	1	435032224R1
R8711	C-CARBON R	RN72K1J-222JE	1	435032224R1
R8712	C-CARBON R	RN72K1J-000JE	1	435030004R1
R8713	C-CARBON R	RN72K1J-000JE	1	435030004R1
R8714	C-CARBON R	RN72K1J-222JE	1	435032224R1
R8715	C-CARBON R	RN72K1J-222JE	1	435032224R1
R8716	C-CARBON R	RN72K1J-222JE	1	435032224R1
R8717	C-CARBON R	RN72K1J-222JE	1	435032224R1
R8718	C-R NET	RM7LJ103X04	1	43484710304R2
R8718 or	C-R NET	YCN104-103-JK	(1)	43464C10304R1
R8721	C-CARBON R	RN72K1J-103JE	1	435031034R1

R8722	C-CARBON R	RN72K1J-222JE	1	435032224R1
R8723	C-CARBON R	RN72K1J-222JE	1	435032224R1
R8724	C-CARBON R	RN72K1J-473JE	1	435034734R1
R8725	C-CARBON R	RN72K1J-103JE	1	435031034R1
R8726	C-CARBON R	RN72K1J-220JE	1	435032204R1
R8727	C-R NET	RM7LJ103X04	1	43484710304R2
R8727 or	C-R NET	YCN104-103-JK	(1)	43464C10304R1
R8728	C-CARBON R	RN72K1J-103JE	1	435031034R1
R8729	C-CARBON R	RN72K1J-000JE	1	435030004R1
R8730	C-CARBON R	RN72K1J-103JE	1	435031034R1
R8731	C-CARBON R	RN72K1J-331JE	1	435033314R1
R8732	C-CARBON R	RN72K1J-472JE	1	435034724R1
R8733	C-CARBON R	RN72K1J-472JE	1	435034724R1
R8734	C-CARBON R	RN72K1J-103JE	1	435031034R1
R8736	C-CARBON R	RN72K1J-103JE	1	435031034R1
R8737	C-CARBON R	RN72K1J-222JE	1	435032224R1
R8738	C-CARBON R	RN72K1J-222JE	1	435032224R1
R8739	C-CARBON R	RN72K1J-472JE	1	435034724R1
R8740	C-CARBON R	RN72K1J-472JE	1	435034724R1
R8741	C-CARBON R	RN72K1J-103JE	1	435031034R1
R8745	C-CARBON R	RN72K1J-103JE	1	435031034R1
R8747	C-CARBON R	RN72K1J-220JE	1	435032204R1
R8748	C-CARBON R	RN72K1J-470JE	1	435034704R1
R8749	C-CARBON R	RN72K1J-470JE	1	435034704R1
R8753	C-CARBON R	RN72K1J-472JE	1	435034724R1
R8754	C-CARBON R	RN72K1J-223JE	1	435032234R1
R8755	C-CARBON R	RN72K1J-331JE	1	435033314R1
R8756	C-CARBON R	RN72K1J-122JE	1	435031224R1
R8757	C-CARBON R	RN72K1J-182JE	1	435031824R1
R8901	C-CARBON R	RN72K1J-103JE	1	435031034R1
R8902	C-CARBON R	RN72K1J-393JE	1	435033934R1
R8903	C-CARBON R	RN72K1J-103JE	1	435031034R1
R8906	C-CARBON R	RN72K1J-272JE	1	435032724R1
R8907	C-CARBON R	RN72K1J-223JE	1	435032234R1
R8908	C-CARBON R	RN72K1J-103JE	1	435031034R1
R8909	C-CARBON R	RN72K1J-223JE	1	435032234R1
R8910	C-CARBON R	RN72K1J-103JE	1	435031034R1
R8911	C-CARBON R	RN72K1J-682JE	1	435036824R1
R8912	C-CARBON R	RN72K1J-104JE	1	435031044R1
R8913	C-CARBON R	RN72K1J-102JE	1	435031024R1
R8931	C-CARBON R	RN72K1J-102JE	1	435031024R1
R8932	C-CARBON R	RN72K1J-104JE	1	435031044R1
R8933	C-CARBON R	RN72K1J-332JE	1	435033324R1
R8934	C-CARBON R	RN72K1J-472FE	1	435034722R1
R8936	C-CARBON R	RN72K1J-103FE	1	435031032R1
R8941	C-CARBON R	RN72K1J-102JE	1	435031024R1
R8942	C-CARBON R	RN72K1J-104JE	1	435031044R1
R8943	C-CARBON R	RN72K1J-472JE	1	435034724R1
R8944	C-CARBON R	RN72K1J-103FE	1	435031032R1
R8946	C-CARBON R	RN72K1J-103FE	1	435031032R1
R8951	C-CARBON R	RN72K1J-102JE	1	435031024R1
R8952	C-CARBON R	RN72K1J-104JE	1	435031044R1
R8953	C-CARBON R	RN72K1J-682JE	1	435036824R1
R8954	C-CARBON R	RN72K1J-333FE	1	435033332R1
R8955	C-CARBON R	RN72K1J-124FE	1	435031242R1
R8956	C-CARBON R	RN72K1J-103FE	1	435031032R1
R8961	C-CARBON R	RN72K1J-104JE	1	435031044R1
R8962	C-CARBON R	RN72K1J-104JE	1	435031044R1
R8963	C-CARBON R	RN72K1J-103JE	1	435031034R1
R8964	C-CARBON R	RN72K1J-473FE	1	435034732R1
R8965	C-CARBON R	RN72K1J-225JE	1	435032254R1
R8966	C-CARBON R	RN72K1J-103FE	1	435031032R1
R8967	C-CARBON R	RN72K1J-104FE	1	435031042R1
R8970	C-CARBON R	RN72K1J-472JE	1	435034724R1
R8971	C-CARBON R	RN72K1J-472JE	1	435034724R1
R8972	C-CARBON R	RN72K1J-472JE	1	435034724R1
[SW TRM]				
E8500	CRIMP AS	---	1	2061712080UL
P2800B	SOCKET	IMSA-9618S-13A	1	25053338R2
P2800Bor	SOCKET	13FMN-SMT-A-TF	(1)	25052830R2
P2801B	SOCKET	IMSA-9618S-09A	1	25053334R2
P2801Bor	SOCKET	09FMN-SMT-A-TF	(1)	25052826R2
P3101A	PLUG	NPLG-5P918	1	25055965R2
P3102A	PLUG	NPLG-5P918	1	25055965R2
P3103A	SOCKET	NSCT-9P2472	1	25052575R2
P3104	SOCKET	RB1-105B8A1F	1	25053409

P3104 or	SOCKET	SI-60073-F	(1)	25053307
P3104 or	SOCKET	EJFR0002	(1)	25056668
P501B	PLUG	NPLG-3P916	1	25055963R2
P701A	SOCKET	IMSA-9618S-23A	1	25053348R2
P701Aor	SOCKET	23FMN-SMT-A-TF	(1)	25052840R2
P751A	SOCKET	NSCT-9P2472	1	25052575R2
P8001B	SOCKET	IMSA-9111S-24L	1	25053259
P8002B	SOCKET	IMSA-9111S-16L	1	25053258
P8003B	SOCKET	IMSA-9111S-16L	1	25053258
P8004B	SOCKET	IMSA-9618S-07A	1	25053332R2
P8004Bor	SOCKET	07FMN-SMT-A-TF	(1)	25052824R2
P8005	TRM-423(SCREW)	NEJITANSI ST3	1	25060495
P801	PLUG	NPLG-2P116	1	25055132
P801B	PLUG	NPLG-3P117	1	25055133
P8030	SOCKET	IMSA-9618S-04A	1	25053329R2
P8030 or	SOCKET	04FMN-SMT-A-TF	(1)	25052821R2
P8101	SOCKET	HDMI(47266-4201)	1	25053522R3
P8101 or	SOCKET	HDMI(47266-4101)	(1)	25053389R3
P8101 or	SOCKET	TCX3423-311387	(1)	25060513R3
P8102	SOCKET	HDMI(47266-4201)	1	25053522R3
P8102 or	SOCKET	HDMI(47266-4101)	(1)	25053389R3
P8102 or	SOCKET	TCX3423-311387	(1)	25060513R3
P8104	SOCKET	NSCT-8P2471	1	25052574R2
P8500	SOCKET	TCX3255-611187	1	25053413R3
P8501	SOCKET	TCX3423-311387	1	25060513R3
P8601	SOCKET	HDMI(47266-4201)	1	25053522R3
P8601 or	SOCKET	HDMI(47266-4101)	(1)	25053389R3
P8601 or	SOCKET	TCX3423-311387	(1)	25060513R3
P861	SOCKET AS	NSAS-3P2098	1	2009991287UL
P8611	SOCKET	HDMI(47266-4201)	1	25053522R3
P8611 or	SOCKET	HDMI(47266-4101)	(1)	25053389R3
P8611 or	SOCKET	TCX3423-311387	(1)	25060513R3
P861A	WIRE HOL	NSCT-3P874	1	25051087
P861B	PLUG	NPLG-3P916	1	25055963R2
P8621	SOCKET	HDMI(47266-4201)	1	25053522R3
P8621 or	SOCKET	HDMI(47266-4101)	(1)	25053389R3
P8621 or	SOCKET	TCX3423-311387	(1)	25060513R3
P8631	SOCKET	HDMI(47266-4201)	1	25053522R3
P8631 or	SOCKET	HDMI(47266-4101)	(1)	25053389R3
P8631 or	SOCKET	TCX3423-311387	(1)	25060513R3
P8641	SOCKET	HDMI(47266-4201)	1	25053522R3
P8641 or	SOCKET	HDMI(47266-4101)	(1)	25053389R3
P8641 or	SOCKET	TCX3423-311387	(1)	25060513R3
P8651	SOCKET	HDMI(47266-4201)	1	25053522R3
P8651 or	SOCKET	HDMI(47266-4101)	(1)	25053389R3
P8651 or	SOCKET	TCX3423-311387	(1)	25060513R3
P8661	SOCKET	HDMI(47266-4201)	1	25053522R3
P8661 or	SOCKET	HDMI(47266-4101)	(1)	25053389R3
P8661 or	SOCKET	TCX3423-311387	(1)	25060513R3
P8671	SOCKET	HDMI(47266-4201)	1	25053522R3
P8671 or	SOCKET	HDMI(47266-4101)	(1)	25053389R3
P8671 or	SOCKET	TCX3423-311387	(1)	25060513R3
P8702	SOCKET	NSCT-9P2472	1	25052575R2
P8710	PLUG	NPLG-2P568	1	25055600
P8901	SOCKET	NSCT-8P2471	1	25052574R2
P901B	PLUG	NPLG-5P918	1	25055965R2

ONKYO

Onkyo Corporation

Technical Support, Service Department
2-1, Nisshin-cho, Neyagawa-shi, OSAKA 572-8540, JAPAN
Tel: 072-831-8023 Fax: 072-831-8163

Onkyo U.S.A. Corporation

18 Park Way, Upper Saddle River, N.J. 07458, U.S.A.
Tel: 800-229-1687, 201-785-2600 Fax: 201-785-2650
<http://www.us.onkyo.com/>

Onkyo Europe Electronics GmbH

Liegnitzerstrasse 6, 82194 Groebenzell, GERMANY
Tel: +49-8142-4401-0 Fax: +49-8142-4208-213
<http://www.eu.onkyo.com/>

Onkyo Europe Electronics GmbH (UK Branch)

The Coach House 81A High Street, Marlow, Buckinghamshire, SL7 1AB, UK
Tel: +44-(0)1628-473-350 Fax: +44-(0)1628-401-700

Onkyo China Limited

Unit 1033, 10/F, Star House, No 3, Salisbury Road, Tsim Sha Tsui Kowloon, Hong Kong.
Tel: 852-2429-3118 Fax: 852-2428-9039
<http://www.onkyochina.com/>

Onkyo China PRC

1301, 555 Tower, No.555 West NanJin Road, Jin an, Shanghai,
China 200041, Tel: 86-21-52131366 Fax: 86-21-52130396
<http://www.cn.onkyo.com/>