

TO NAAF-9039
SD-5:H3

NACLA-9064

U19 DRIVER AMP PC BOARD

FRONT R

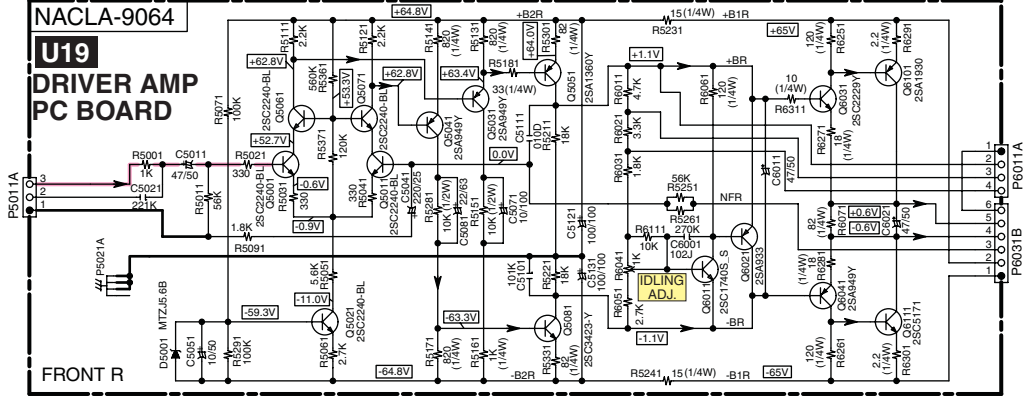

TO NAAMP-9062 TO NAAF-9039
SD-4:B1 SD-5:H3

FRONT R

POWER AMP
PC BOARD



+0.6V

-0.6V

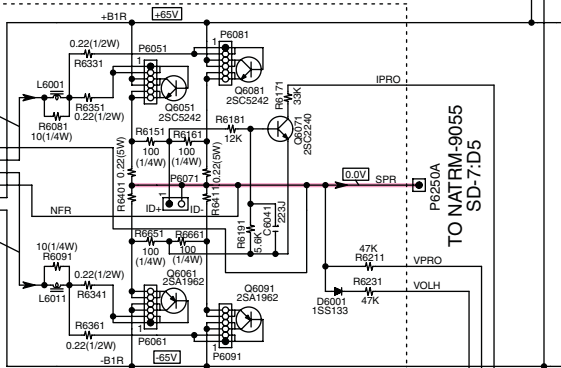

TO NATRM-9055
SD-7:D5

+B
-B