

ONKYO SERVICE MANUAL

COMPUTER CONTROLLED

AV TUNER AMPLIFIER

MODEL TX-RV47



SAFETY-RELATED COMPONENT WARNING!!

COMPONENTS IDENTIFIED BY MARK Δ ON THE SCHEMATIC DIAGRAM AND IN THE PARTS LIST ARE CRITICAL FOR RISK OF FIRE AND ELECTRIC SHOCK. REPLACE THESE COMPONENTS WITH ONKYO PARTS WHOSE PART NUMBERS APPEAR AS SHOWN IN THIS MANUAL.

MAKE LEAKAGE-CURRENT OR RESISTANCE MEASUREMENTS TO DETERMINE THAT EXPOSED PARTS ARE ACCEPTABLY INSULATED FROM THE SUPPLY CIRCUIT BEFORE RETURNING THE APPLIANCE TO THE CUSTOMER.



SPECIFICATIONS

AMPLIFIER SECTION

Power Output:	55 watts per channel, min. RMS, at 8 ohms, both channels driven, from 20Hz to 20kHz, with no more than 0.08% THD.
Total Harmonic Distortion:	0.08% at 1W 0.08% at rated power
IM Distortion:	0.08% at 1W 0.08% at rated power
Damping Factor:	35 at 8 ohms
Frequency Response:	20 – 30,000 Hz \pm 1dB
RIAA Deviation:	20 – 20,000 Hz \pm 0.8dB
Sensitivity and Impedance:	Phone: 2.5mV/50 kohms Tape Play: 150mV/50 kohms Tape Rec: 150mV/3.5 kohms (phono)
Phono Overload:	150mV RMS at 1kHz, 0.08% THD
Signal-to-Noise Ratio:	Phono: 83dB (at 10mV input, A weighted) 73dB (IHF A202) CD/Tape: 93dB (A weighted) 78dB (IHF A-202)
Tone Controls:	Bass: \pm 8.5dB at 100Hz Treble: \pm 8.5dB at 10kHz
Loudness(–30dB):	+7dB at 70Hz, +5dB at 10kHz
Muting:	–20dB

TUNER SECTION

FM:

Tuning Range:	87.9 – 107.9 MHz (200kHz steps)
Usable Sensitivity:	Mono: 11.2dBf, 2.0 μ V Stereo: 17.2dBf, 4.0 μ V
50dB Quieting Sensitivity:	Mono: 17.2dBf, 4.0 μ V Stereo: 37.2dBf, 40 μ V
Capture Ratio:	1.5dB
Image Rejection Ratio:	40dB
IF Rejection Ratio:	90dB
Signal-to-Noise Ratio:	Mono: 71dB Stereo: 66dB
Alternate Channel Attenuation:	55dB
AM Suppression Ratio:	50dB
Harmonic Distortion:	Mono: 0.15% Stereo: 0.3%
Frequency Response:	30 – 15,000Hz \pm 1.5dB
Stereo Separation:	40dB at 1kHz 30dB at 100 – 10,000Hz
Muting Level:	17.2dBf, 4.0 μ V
Stereo Threshold:	17.2dBf, 4.0 μ V

AM:

Tuning Range:	530 – 1620kHz (10kHz steps)
Usable Sensitivity:	30 μ V
Image Rejection Ratio:	40dB
IF Rejection Ratio:	40dB
Signal-to-Noise Ratio:	40dB
Harmonic Distortion:	0.7%

GENERAL

Power Supply:	AC120V, 60Hz
Semiconductors:	FETs: 7 TR: 51 ICs: 32 Diodes: 61 LEDs: 41
Dimensions (W x H x D):	435 x 120 x 392mm 17-1/8" x 4-11/16" x 15-7/16"
Weight:	9.5 kg., 20.9 lbs.

RC-47 Remote Control Unit

Transmitter:	Infrared
Signal range:	Approx. 5 meters
Power supply:	Two "AA" batteries (1.5V x 2)
Dimensions:	55(W)x19(H)x167(D)mm
Weight:	120 grams (including batteries)

Specifications and features are subject to change without notice

SERVICE PROCEDURES

1. Replacing the fuse

For continued protection against fire hazard, replace only with same type and same rating fuse.

Circuit No.	Part No.	Description
F921	252049	4A (ST-6), Primary fuse

2. Safety-check out

After correcting the original service problem, perform the following safety check before releasing the set to the customer:

Connect the insulating-resistance tester between the plug of power supply cable and terminal GND on the back panel.

Specification: $3.3M\Omega \pm 10\%$ at 500V

3. Memory Preservation

This unit does not require memory preservation batteries. A built-in memory power back-up system preserves contents of the memory during power failures and even when the unit is unplugged. The unit must be plugged in and the power switch turned on and off once in order to charge the back-up system. Note that since this is not a permanent memory, the power switch must be turned on and off a few times each month to keep the back-up system operable. The period of time during which memory contents are preserved after power has last been turned off varies depending on climate and the location and placement of the unit. On the average, memory contents are protected over a period of 3 to 4 weeks (a minimum of 2 weeks) after the last time power has been turned off. This period is shorter when the unit is exposed to very high humidity or used in an area with an extremely humid climate.

4. Remote Control Operator Batteries

The remote control operator is powered by two batteries. Before using this unit for the first time, insert the two batteries (included). The remote control operator has no on/off switch. Average battery life is one year. This period may be shorter depending on the frequency of use and environment (temperature and humidity) in which the remote control operator is used. If the remote control does not operated even through front panel controls function normally, the batteries should be replaced. Used only batteries listed in the following chart.

Type	Voltage	ANSI	NEDA	Eveready	Mallory
Manganese	1.5V	AA	15P	815	M15P
			15P	915	M15F
			15	1015	M150F
			15D	1215	M1504

Ray-O-Vac	Bright Star	Burgess	RCA	Sears	IEC
710	59P	920	VS734	8950	R6
7AA	59	910	VS034A		
15	0199	930	VS334		
5AA					

5. Replacing the lamp

This unit uses the lamp listed below.

Circuit no.	Part no.	Description
PL701	210064A	PL 6.3V, 250mA, Dial plate illumination

TABLE OF CONTENTS

Specifications	2	Printed circuit board view & parts list	17
Service procedures	3	Tuner circuit pc board	17
Block diagram — tuner section —	4	Video selector circuit pc board	18
Block diagram — amp section —	5	Digital circuit pc board	21
Exploded view	6	Display circuit pc board	22
Parts list	7	Tone control circuit pc board	23
Circuit Description & IC block diagram	8	Power supply circuit pc board	24
Microcomputer operation	8	Pre./Main circuit and power supply circuit	25
Block diagram & description	10	Display circuit pc board	30
Dynamic bass expander	14	Schematic diagram — tuner section —	19
Adjustment procedures	15	Schematic diagram — amp section —	27
		System connection diagram	31
		Packing view	32

BLOCK DIAGRAM

— Tuner Section —

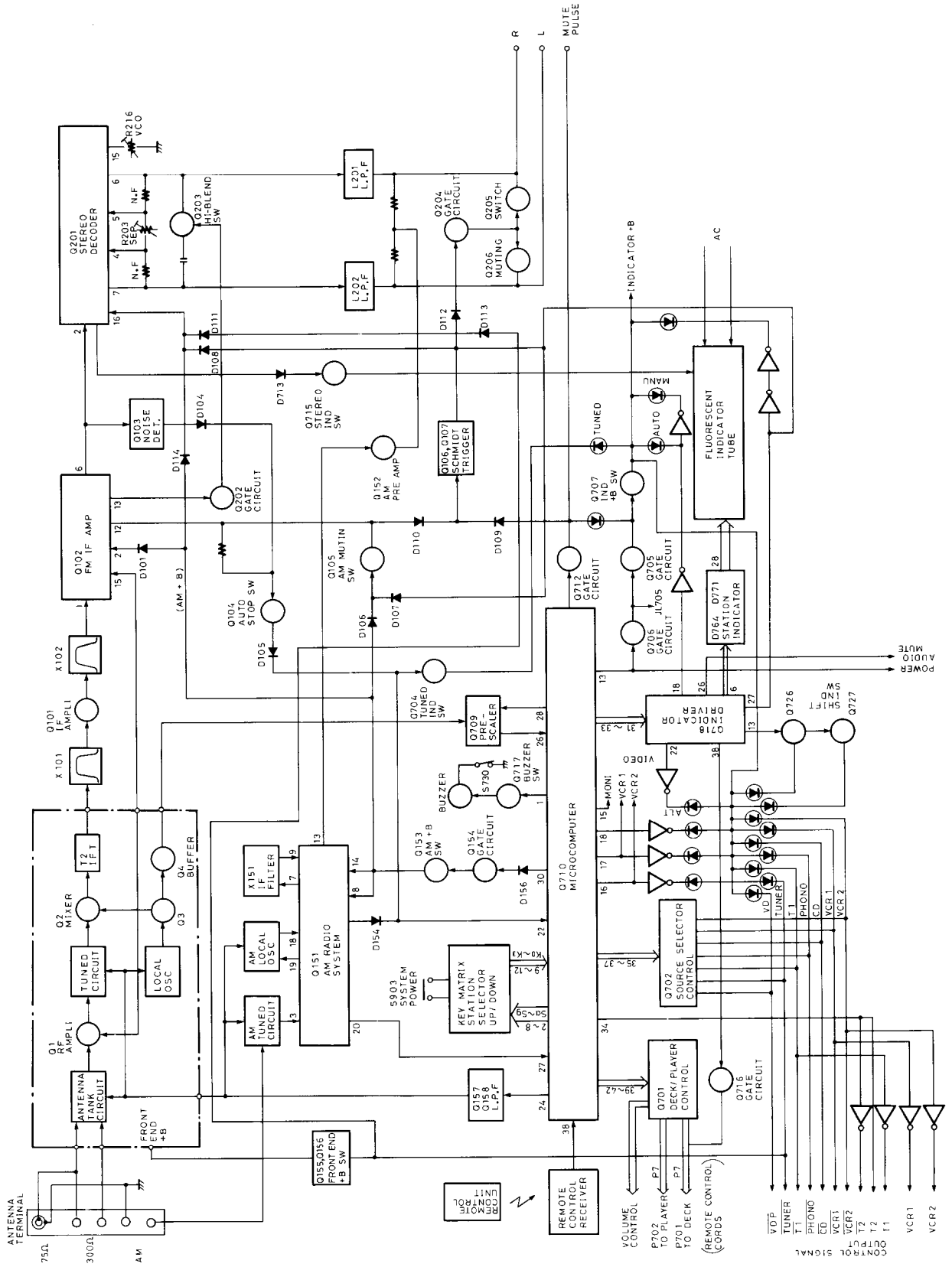

EXPLODED VIEW

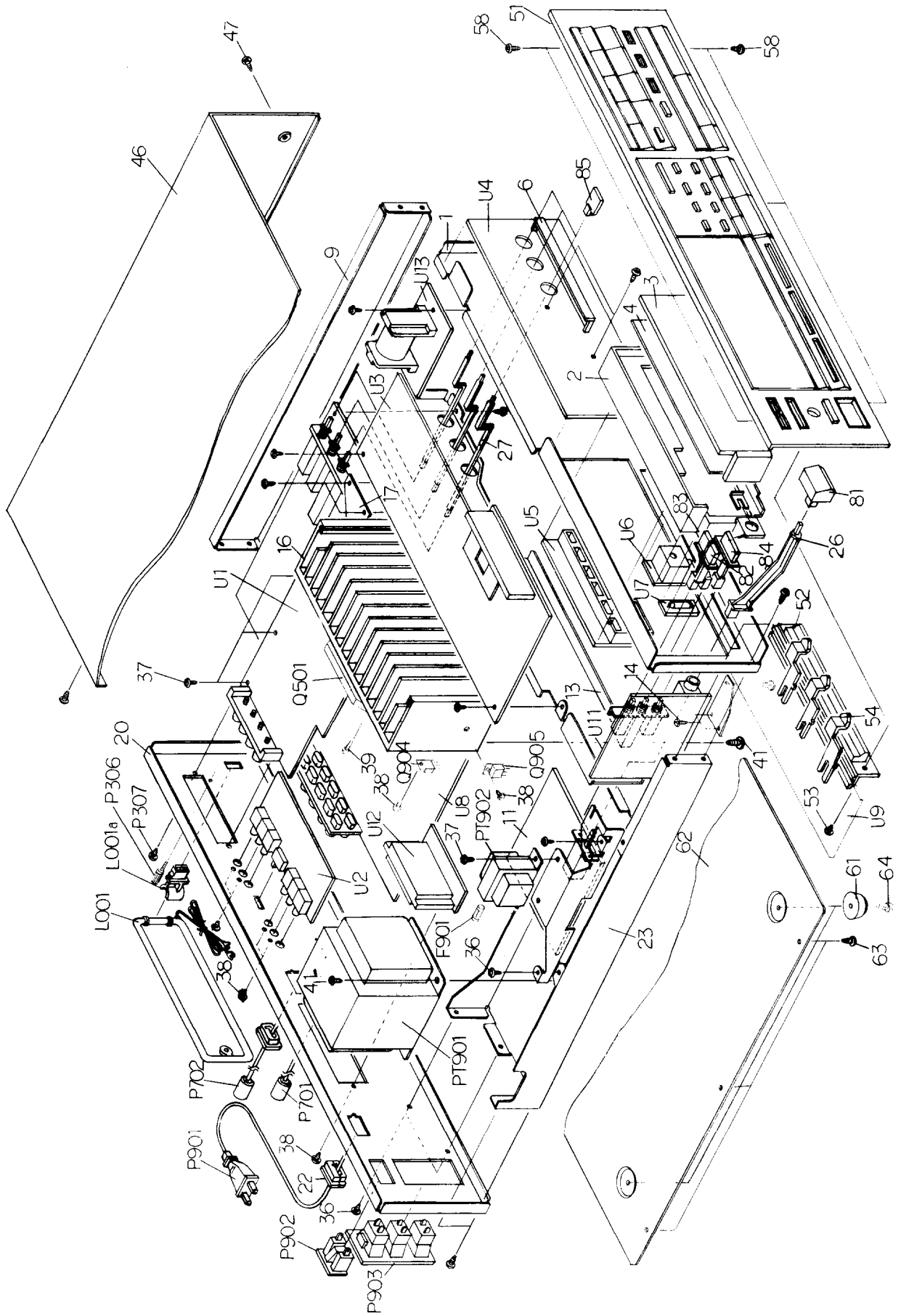

PARTS LIST

REF. NO.	PART NO.	DESCRIPTION	REF. NO.	PART NO.	DESCRIPTION
1	27110264A	Front bracket	85	28322335	Knob, push
2	27190414	Holder	F901	252049	4A (ST-6), Fuse
3	28130232A	Dial plate	L001	232085	NMA-3034, AM loop antenna
4	28133153	Back plate	L001a	27190105	Holder, antenna
6	27262385A	Plate B	P306	25060044	3x14, Terminal, ground
9	27115196	Side bracket R	P701	2010122	Cord, control, remote, phone
11	27141036A	Bracket, power transformer	P702	2010123	Cord, control, remote, cassette
13	27130412	Bracket, center	P901	253123	AS-UC-6#18, Power supply cord
14	27141037	Bracket, pc board	P902	25050118	NSCT-2P-26T, AC outlet
16	27160180	Radiator	P903	25050216	NSCT-6P44, AC outlet
17	27141038A	Bracket, radiator	PT901	2300039	NPT-901D, Power transformer
20	27120781	Back panel	PT902	2300040	NPT-902D, Power transformer
22	27300750	Strainrelief	Q501	222043	STK-4181V, Power amplifier IC
23	27130411A	Bracket, power transformer	Q904	222780122	78M12, Constant voltage IC
26	27273036	Joint	Q905	2201404 or	2SD1406 (Y) or
27	27273046	Joint, push	U1	18588571	NARF-2471-1, Tuner circuit pc board ass'y
28	27141048	Bracket Z	U2	18588572	NASEL-2472-1, Video selector circuit pc board ass'y
35	838430068	3TTB+6B (BC), Tapping screw	U3	18588573	NADG-2473-1, Digital circuit pc board ass'y
36	834430068	3TTS+6B (BC), Tapping screw	U4	18588574	NADIS-2474-1, Display circuit pc board ass'y
37	831130088	3TTW+8B, Tapping screw	U5	18588575	NADIS-2475-1, Display circuit pc board ass'y
38	834430108	3TTS+10B (BC), Tapping screw	U6	18588576	NADG-2476-1, Remote control receiver circuit pc board ass'y
39	834430168	3TTS+16B (BC), Tapping screw	U7	18588577	NAPL-2477-1, Dial illumination pc board ass'y
41	830440089	4TTC+8C (BC), Tapping screw	U8	18588578	NAAF-2478-1, Pre./Main amplifier and power supply circuit pc board ass'y
43	82143006	3P+6FN(BC), Pan head screw	U9	18588579	NATC-2479-1, Volume and tone control circuit pc board ass'y
46	28184303	Top cover	U10	18588580	NAPS-2480-1, Power supply circuit pc board ass'y
47	834430068	3TTS+6B (BC), Tapping screw	U11	18588581	NASW-2481-1, Speaker switch pc board ass'y
51	18588121	Front panel ass'y	U12	18588582	NATRM-2482, Speaker terminal pc board ass'y
52	28400249	Rail, slide	U13	18588583	NAMR-2483-1, Matrix circuit pc board ass'y
53	28322332	3TTP+8P (BC), Tapping screw			
54	2832232	Knob, slide			
58	838430068	3TTB+6B (BC), Tapping screw			
61	27170214A	Bottom board			
62	27175009A	Leg			
63	834430068	3TTS+6B (BC), Tapping screw			
64	831430088	3TTW+8B (BC), Tapping screw			
81	28321905B	Knob, power			
82	28322304	Knob, speaker A			
83	28322305	Knob, speaker B			
84	28322306	Knob, channel 4			

NOTE: THE COMPONENTS IDENTIFIED BY MARK **A** ARE CRITICAL FOR RISK OF FIRE AND ELECTRIC SHOCK. REPLACE ONLY WITH PARTS NUMBER SPECIFIED.

CIRCUIT DESCRIPTION AND IC BLOCK DIAGRAM

Microcomputer operation

μ PD-1712CU-527 (Synthesizer and controller)

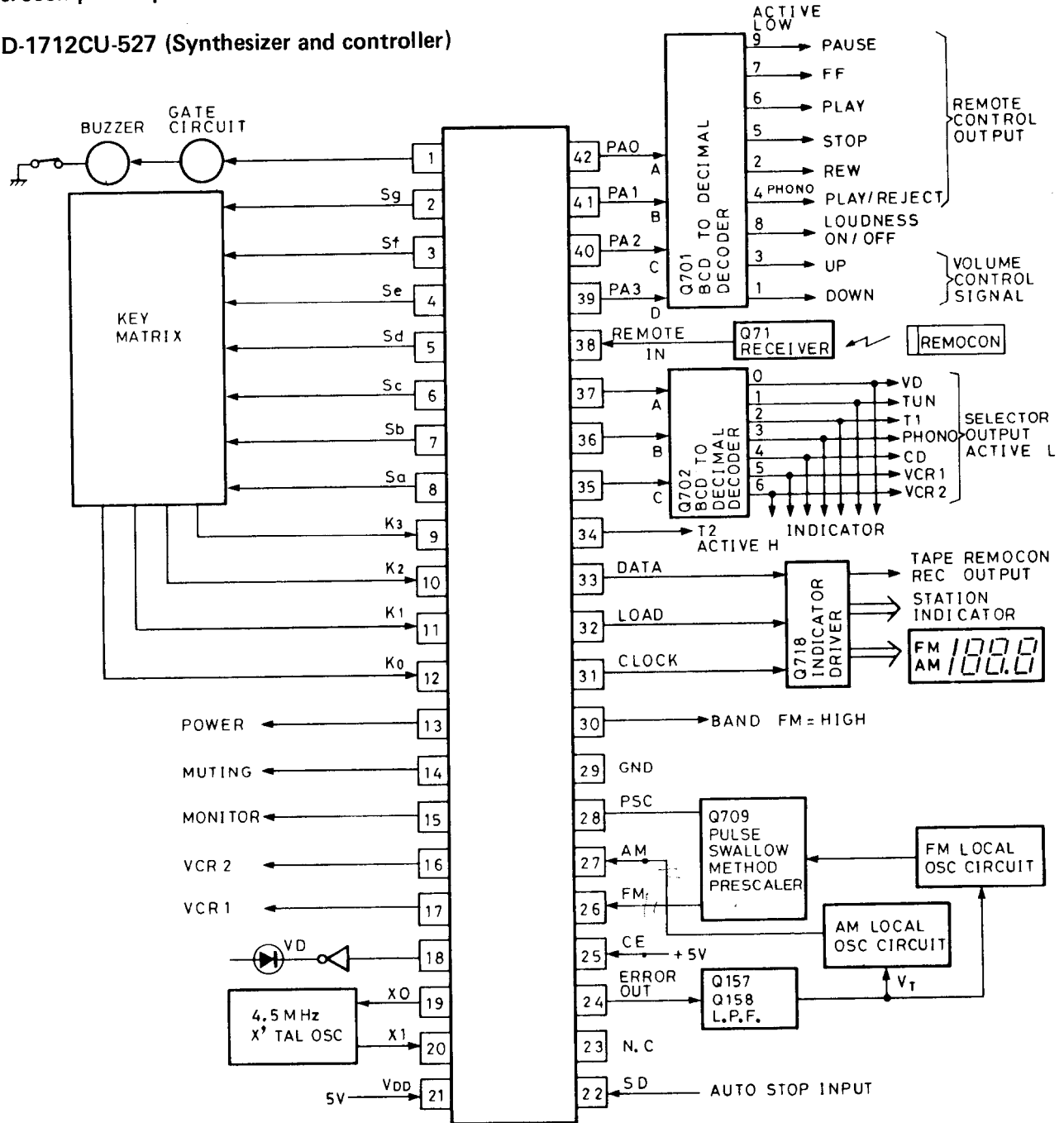

Pin No.	Symbol	Description
1	CPG	Clock pulse output for buzzer when pressed the operation keies and auto-tuning.
2	Sg	Key return signal source output terminals.
3	Sf	
4	Se	
5	Sd	
6	Sc	
7	Sb	
8	Sa	

Pin No.	Symbol	Description																																																		
9 10 11 12	K3 K2 K1 K0	Key return signal input terminals.																																																		
13	POWER	System power control output. Active high.																																																		
14	MUTE	Goes to the high level during muting control signal output. Active high.																																																		
15	MONITOR	Monitor output terminal for control of video. Active high.																																																		
16	VCR2	VCR2 output terminal for control of video. Active high.																																																		
17	VCR1	VCR1 output terminal for control of video. Active high.																																																		
18	VD	Output terminal for indicator VD. Active high.																																																		
19 20	X0 X1	Connect to the 4.5MHz crystal oscillator.																																																		
21	VDD	Device power terminal; supplies 5V during normal operation and 3V from the super capacitor C703 for memory preservation.																																																		
22	SD	Station detector input terminal. When this terminal goes to the high level, auto search tuning is stopped.																																																		
23 24	E02 E01	Charge pump output of the phase detector which constitutes the PLL. High level is output when the divided local oscillator frequency is high than the reference frequency. In the opposite case, low level is output. Floating occurs when the frequencies matched. The output is applied to the variable capacitor diode in the local oscillator circuit of AM/FM through low pass filter Q157 and Q158. The output from both terminals is the same, but only E01 is used.																																																		
25	CF	Chip enable input. Device selection signal terminal. High level ... Normal operation Low level ... Memory preservation.																																																		
26	FM	Local oscillator frequency input terminal is divided by prescaler Q709.																																																		
27	AM	Local oscillator frequency input terminal.																																																		
28	PSC	Output terminal to control the division ratio of the prescaler Q709.																																																		
29	GND	Ground terminal																																																		
30	FM/AM	FM/AM band selector output. FM at the high level and AM at the low level.																																																		
31	CK	Clock output for indicator driver IC Q718.																																																		
32	LOAD	Load output for indicator driver IC Q718.																																																		
33	DATA	Data output for indicator driver IC Q718.																																																		
34	TAPE 2	TAPE 2 control output terminal. Active high.																																																		
35	PC2 (C)	BCD code output for source selector.																																																		
36	PC1 (B)																																																			
37	PC0 (A)																																																			
			<table border="1"> <thead> <tr> <th></th> <th>VD</th> <th>TUNER</th> <th>TAPE 1</th> <th>PHONO</th> <th>CD</th> <th>VCR 1</th> <th>VCR 2</th> </tr> </thead> <tbody> <tr> <td>C</td> <td>0</td> <td>0</td> <td>0</td> <td>0</td> <td>1</td> <td>1</td> <td>1</td> </tr> <tr> <td>B</td> <td>0</td> <td>0</td> <td>1</td> <td>1</td> <td>0</td> <td>0</td> <td>1</td> </tr> <tr> <td>A</td> <td>0</td> <td>1</td> <td>0</td> <td>1</td> <td>0</td> <td>1</td> <td>0</td> </tr> </tbody> </table>		VD	TUNER	TAPE 1	PHONO	CD	VCR 1	VCR 2	C	0	0	0	0	1	1	1	B	0	0	1	1	0	0	1	A	0	1	0	1	0	1	0																	
	VD	TUNER	TAPE 1	PHONO	CD	VCR 1	VCR 2																																													
C	0	0	0	0	1	1	1																																													
B	0	0	1	1	0	0	1																																													
A	0	1	0	1	0	1	0																																													
38	INT	Remote control input.																																																		
39	PA3 (D)	BCD code outputs for the electron volume and remote control signal for tape deck and turntable.																																																		
40	PA2 (C)																																																			
41	PA1 (B)																																																			
42	PA0 (A)																																																			
			<table border="1"> <thead> <tr> <th></th> <th>DOWN</th> <th>REW</th> <th>UP</th> <th>PLAY/REJ</th> <th>STOP</th> <th>PLAY</th> <th>FF</th> <th>LOUD</th> <th>PAUSE</th> </tr> </thead> <tbody> <tr> <td>D</td> <td>0</td> <td>0</td> <td>0</td> <td>0</td> <td>0</td> <td>0</td> <td>0</td> <td>1</td> <td>1</td> </tr> <tr> <td>C</td> <td>0</td> <td>0</td> <td>0</td> <td>1</td> <td>1</td> <td>1</td> <td>1</td> <td>0</td> <td>0</td> </tr> <tr> <td>B</td> <td>0</td> <td>1</td> <td>1</td> <td>0</td> <td>0</td> <td>1</td> <td>1</td> <td>0</td> <td>0</td> </tr> <tr> <td>A</td> <td>1</td> <td>0</td> <td>1</td> <td>0</td> <td>1</td> <td>0</td> <td>1</td> <td>0</td> <td>1</td> </tr> </tbody> </table>		DOWN	REW	UP	PLAY/REJ	STOP	PLAY	FF	LOUD	PAUSE	D	0	0	0	0	0	0	0	1	1	C	0	0	0	1	1	1	1	0	0	B	0	1	1	0	0	1	1	0	0	A	1	0	1	0	1	0	1	0
	DOWN	REW	UP	PLAY/REJ	STOP	PLAY	FF	LOUD	PAUSE																																											
D	0	0	0	0	0	0	0	1	1																																											
C	0	0	0	1	1	1	1	0	0																																											
B	0	1	1	0	0	1	1	0	0																																											
A	1	0	1	0	1	0	1	0	1																																											

TC9185P (Electron Volume Controller)

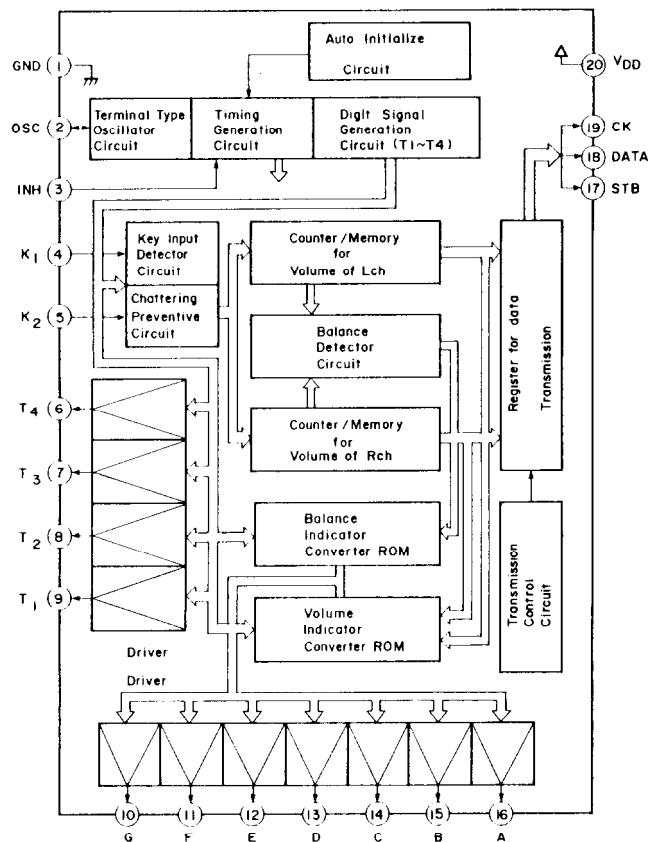

TA7348P (Three Input Switch)

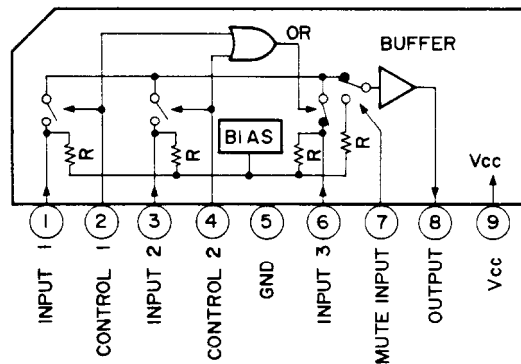

CONTROL 1 VCR 1	CONTROL 2 VCR 2	MUTE IN MONITOR	OUTPUT	
H	L	L	INPUT 1	VCR1
L	H	L	INPUT 2	VCR2
L	L	L	INPUT 3	VD
H	H	L	UNDEFINED	
*	*	H	NONE	

*: Don't care

Pin No.	Symbol	Description
1 20	GND V _{DD}	Ground terminal Power supply terminal
2	OSC	Terminal for oscillator: The oscillator is composed of an external circuit of C721 and R803. This generates the clock (100kHz) required for the system.
3	INH	Inhibit terminal: When INH = "H", there is normal operation, and when INH = "L", operation is inhibited. With low current consumption, volume/balance data are maintained. When INH goes from "L" to "H", the built in power source voltage detection circuit operates, and when $V_{DD} \leq V_{INT}$, the volume/balance data are initialized.
4 5	K1 K2	Key input terminals: K1 and K2 make up the T1 to T4 digital output and matrix, and a maximum of 8 switches can be connected.
6 7 8 9	T4 T3 T2 T1	Digital drive output terminals: These are the common terminals for the LED display. They are also used for the key matrix scan signal.
10 11 12 13 14 15 16	G F E D C B A	Segment drive output terminals: These are the terminals for the segment drive of the display LED. T1 and T2 serve the volume display 14 point matrix, and T3 and T4 serve the balance display 13 point matrix.
17 18 19	STB DATA CK	Serial control output terminals: These terminals provide for the transmission of the data in the electronic volume IC.

TC9177P (Electron Volume)

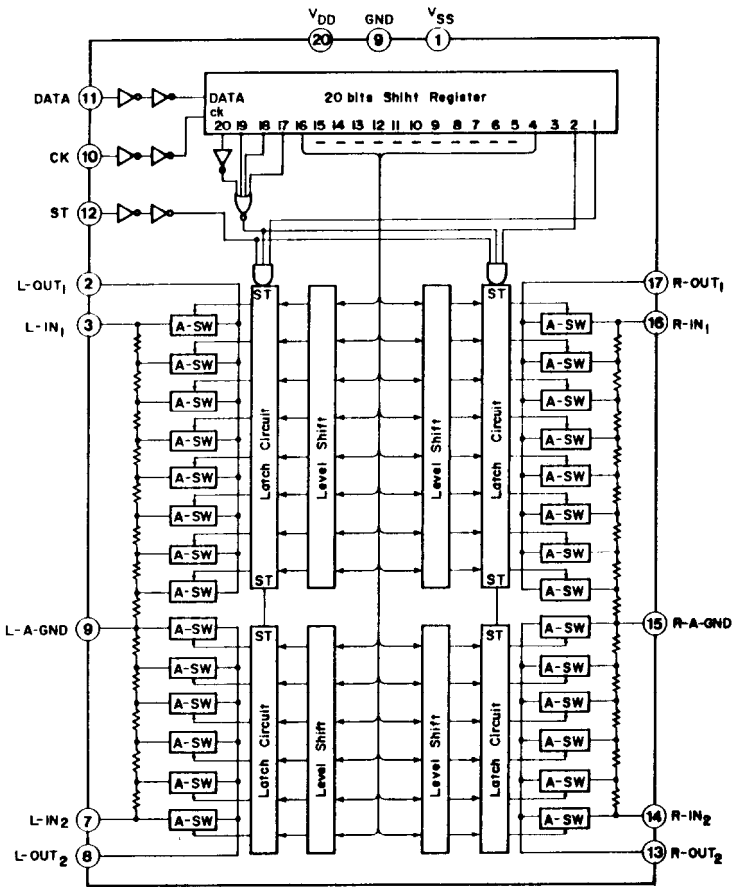
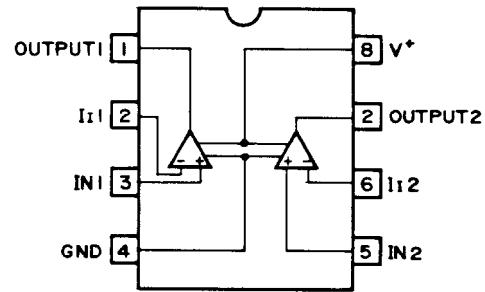
 μ PC393C (Comparator)

TD62551S (Single Driver)

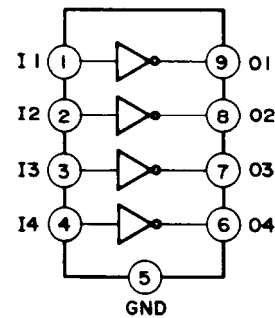

Pin No.	Symbol	Description
2, 3	L-Loudness 1, 2	Terminals for loudness.
19, 18	R-Loudness 1, 2	Terminals for loudness: When the loudness data is input, these terminals become the -20dB tap terminals. By means of the connection of the high and low boost circuit to these terminals, the loudness control circuit can be brought into operation.
4 17	L-OUT1 R-OUT1	10dB step attenuator output: The signal applied to the IN terminals is attenuated in 10dB steps from 0 to 70dB in 8 stages.
5 16	L-IN1 R-IN1	10dB attenuator input
6, 15	A-GND	AC ground terminal
7 14	L-IN2 R-IN2	2dB attenuator
8 13	L-OUT2 R-OUT2	2dB attenuator output: The signal applied to the IN terminals is attenuated in 2dB steps from 0 to 8dB in 5 stages.
11	DATA	Attenuation level and channel selection data input: Input is accomplished with the CK signal composed of 20 bits.
10	CK	Clock input: The clock input is for the purpose of feeding in the data terminal data.
12	ST	Strobe input: The attenuation level and channel selection data fed in from the DATA and CK terminals are lapped by means of an "H" level at these terminals. When an "H" level is not impressed at these terminals, the previous data remains as is.
20 9 1	VDD GND VSS	Power supply terminal Ground terminal Power supply terminal

74LS145 (BCD to Decimal Decoder/Driver)

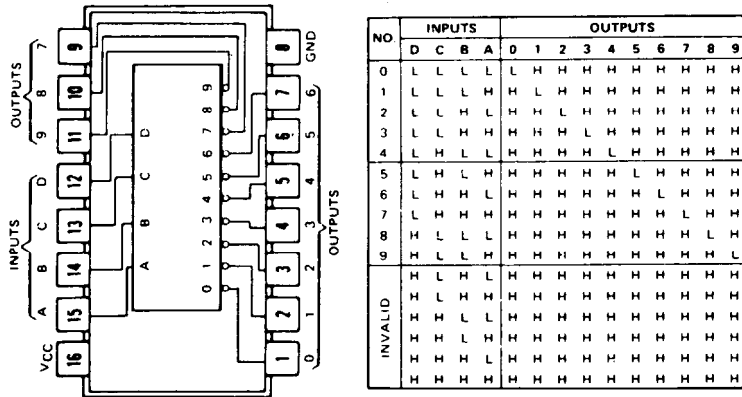

4066B (Analog Switch)

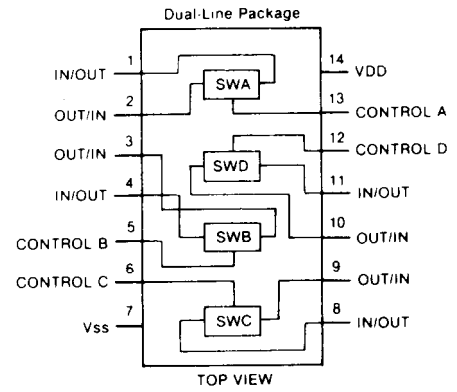

NJM4558/4559 (Operational Amplifier)

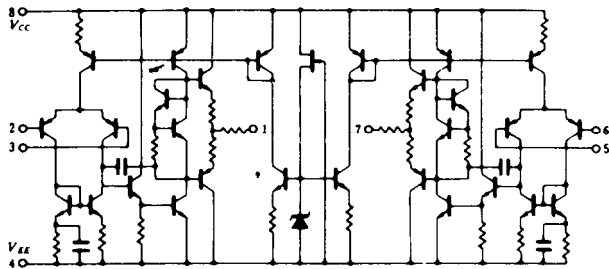

STK4181V (Power Amplifier)

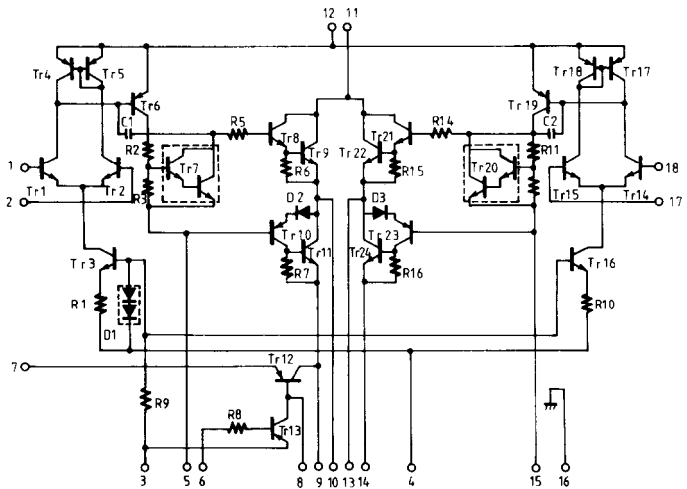

Dynamic Bass Expander Circuit

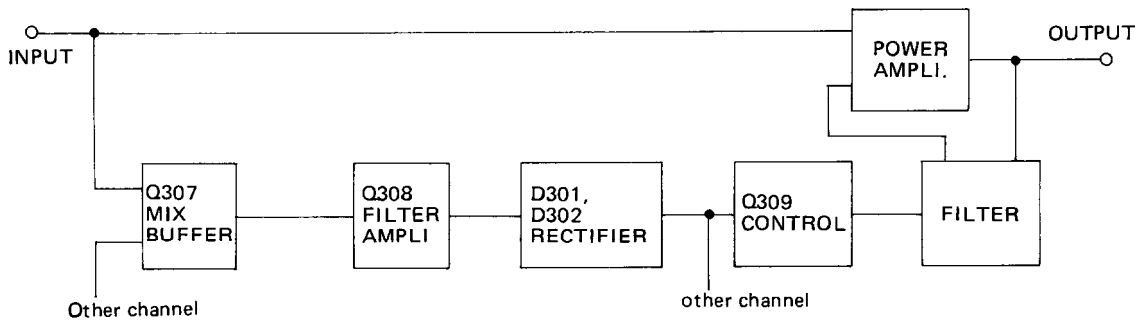

In earlier super base systems, only the frequencies about 70Hz were boosted by about 4dB expand the playback frequency response to enable playback of the super low region. However, when there was no input signal, the above frequency response resulted in deterioration in the S/N ratio in the 70Hz region. This problem had been overcome by the dynamic bass expander where the 70Hz boosted level is varied according to the input signal level. That is, the frequency response remains flat when no input signals

applied, but is boosted at the 70Hz region to the specified level when the input signal exceeds a certain level. The left and right channel input signals from the INPUT terminals are mixed by Q307 and pass through the filter amplifier. The signal is rectified by D306 and D302, and the resultant DC component control signal is applied to the gate of Q309. When the input signal is at a adequate level, Q308 is turned on and the super base circuit of power amplifier is controlled by the input signal.

ADJUSTMENT PROCEDURES

FM section

Item	Step	Connection of instrument	FM SG output	Stereo modulator output	Turning dial setting	Output indicator	Adjustment	Adjust for	Remarks
FM RF		Fig. 1	—	—	88.1 MHz	Digital DC voltmeter	LO	1.4V	Usually not necessary to adjust.
	1	Fig. 2	99.1 MHz 1 kHz, 75 kHz devi. 65 dBf (60dB)	—	99.1 MHz	DC voltmeter	L102 Primary coil	0V	Muting switch: off Repeat the steps 1 and 2 until no further adjustment is necessary
FM IF	2	Fig. 2	99.1 MHz 1 kHz, 75 kHz devi. 65 dBf (60 dB)	—	99.1 MHz	Distortion analyzer	L102 Secondary coil	Minimum	
		Fig. 3	99.1 MHz 1 kHz, 75 kHz devi. 65 dBf (60 dB)	—	99.1 MHz	Frequency counter	R216	19 kHz \pm 10 Hz	Muting switch: on
VCO		Fig. 3	99.1 MHz 65 dBf (60 dB) Ext. modulation	L + R 1 kHz	99.1 MHz	Distortion analyzer	IF on front end	Minimum	
		Fig. 3	99.1 MHz 65 dBf (60 dB) Ext. modulation	L ch. 1 kHz R ch. 1 kHz	99.1 MHz	R ch. AC voltmeter L ch. AC voltmeter	R203	Minimum Minimum	Maximum and same separation
Distortion	1	Fig. 2	99.1 MHz 17.2 dBf (12 dB) 1 kHz, 75 kHz devi.	—	99.1 MHz	Oscilloscope	R116	Signal output	Muting switch: on
	2	Fig. 2	99.1 MHz 16.2 dBf (11 dB) 1 kHz, 75 kHz devi.	—	99.1 MHz	Oscilloscope	R116	No output	

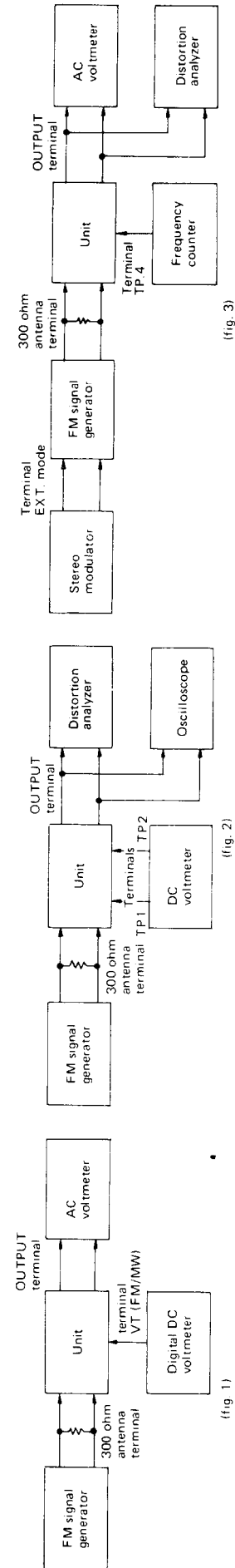

AM section

Step	AM SG output	Tuned frequency	Output indicator	Adjustment point	Adjust for	Remarks
1		530 kHz	Digital DC voltmeter	L153	1.2V	Repeat the steps 1 and 2 until no further adjustment is necessary.
2		1620 kHz	Digital DC voltmeter	C170	9.5V	
3	600 kHz 400 Hz 30% mod.	600 kHz	AC voltmeter	L151	Maximum	Repeat the steps 3 and 4 until no further adjustment is necessary.
4	1400 kHz 400Hz 30% mod.	1400 kHz	AC voltmeter	C152	Maximum	
5	1000 kHz 400 Hz 30% mod.	1000 kHz	AC voltmeter	X151	Maximum	

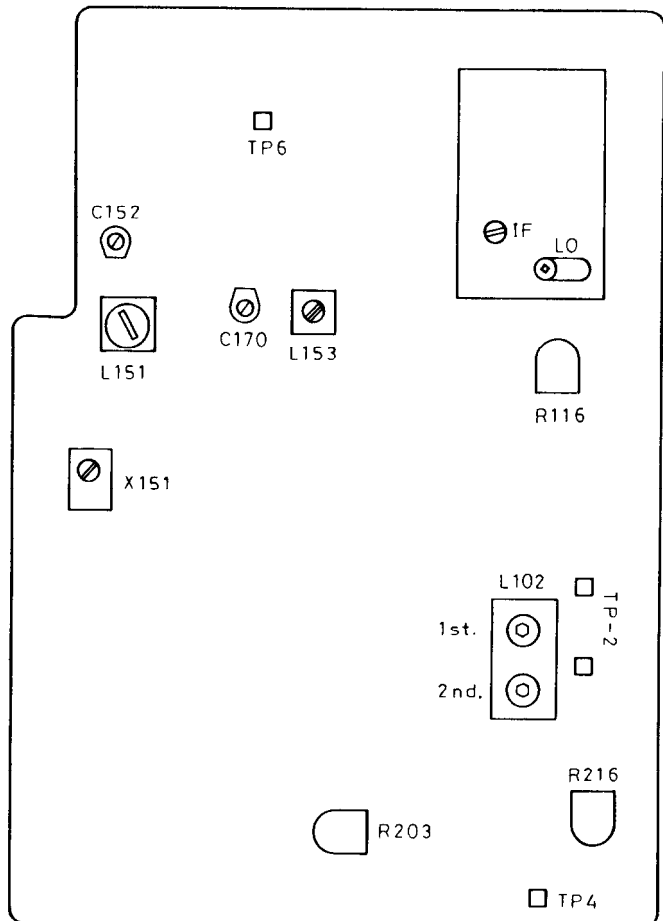
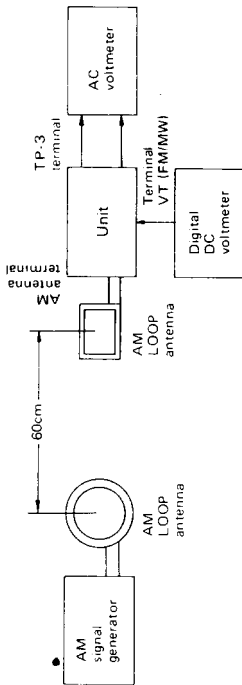

TUNER CIRCUIT PC BOARD (NARF-2471-1)

CIRCUIT NO.	PART NO.	DESCRIPTION			
	Front End				
	240061	FE349U14			
	ICs				
Q102	222540	HA-11225			
Q151	222701	LA1245			
Q201	222678	μPC1161C3			
	Transistors				
Q101	2211722 or 2211723	2SC1923 (R) or 2SC1923 (O)	L101		
Q103-Q107	2211255,	2SC1815 (GR),	L103		
Q153-Q156	2210746 or 2212485	2SC945A (P) or JC501 (Q)	L151		
Q152, Q202	2211256	2SC1815 (BL)	L153		
Q157	2212294 or 2211293	2SK108 (D) or 2SK68 (M)	L201, L202		
Q158	2211255	2SC1815 (GR)	L102		
Q203	2211945 or 2212304	2SK246 (GR) or 2SK381 (D)			
Q204	2211454 or 2212494	2SA1015 (Y) or JA101 (P)	X101, X102		
Q205, Q206	2211705 or 2211706	2SD655 (E) or 2SD655 (F)	X151		
			X152		
				Diodes	
			D101-D114	223150,	US1040,
			D154, D156	223145 or	1S2076TD or
				223124	1S2473
			D151, D152	223140	KV1236
			D153	4000068	VD1222
				Coils	
			L101	233105 or	NCCH1005 or
				233024	NCCH1501
			L103	233031	NMC-9-1
			L151	232113	NMA3049
			L153	232110	NMO4027
			L201, L202	233291	NMC-5039
				Transformer	
			L102	233274	NFIF-6041
				Ceramic Filters	
			X101, X102	3010006	SFE10.7MA8 (RED)
			X151	3010075	SFL450B3
			X152	3010076	BFU450C

CIRCUIT NO.	PART NO.	DESCRIPTION
Capacitors		
C101	352780339	3.3 μ F, 50V, Elect.
C106, C109	352780109	1 μ F, 50v, Elect.
C110	352741009	10 μ F, 16V, Elect.
C116, C119	352784799	0.47 μ F, 50V, Elect.
C121	352780229	2.2 μ F, 50V, Elect.
C122	352741009	10 μ F, 16V, Elect.
C123	352780109	1 μ F, 50V, Elect.
C124	352721019	100 μ F, 6.3V, Elect.
C125	352741019	100 μ F, 16V, Elect.
C152, C170	3060010	NTC-20P09, Trimmer
C158	352741009	10 μ F, 16V, Elect.
C161	352744709	47 μ F, 16V, Elect.
C162	352780109	1 μ F, 50V, Elect.
C165	352750479	4.7 μ F, 25V, Elect.
C166	352741009	10 μ F, 16V, Elect.
C168	370135114	510pF \pm 5%, 100V, APS
C173	352781099	0.1 μ F, 50V, Elect.
C174	352721019	100 μ F, 6.3V, Elect.
C175	352780339	3.3 μ F, 50V, Elect.
C177	395160227	2.2 μ F, 35V, Tantalum
C178	392884797	0.47 μ F, 50V, LL
C201	352750479	4.7 μ F, 25V, Elect.
C202	352744719	470 μ F, 16V, Elect.
C209, C210	352741009	10 μ F, 16V, Elect.
C212	352782299	0.22 μ F, 50V, Elect.
C213	352780109	1 μ F, 50V, Elect.
C124	352780339	3.3 μ F, 50V, Elect.
C215	370134714	470pF \pm 5%, 100V, APS
C216	352741009	10 μ F, 16V, Elect.
C219, C220	352780229	2.2 μ F, 50V, Elect.
Resistors		
R116	5215045	N08HR10KBC, Semi-fixed
R203	5215048	N08HR200KBC, Semi-fixed
R216	5215044	N08HR5KBC, Semi-fixed
Sockets		
	25050267	NSCT-3P95
	25050270	NSCT-6P98
Terminal		
P001	25060091	NTM-5PDMN32, Antenna

VIDEO SELECTOR CIRCUIT PC BOARD (NASEL-2472-1)

CIRCUIT NO.	PART NO.	DESCRIPTION
ICs		
Q252	222927	TA7348P
Q259	222575 or 222840661	TC4066BP or 4066B
Transistors		
Q251	2211705 or 2211706	2SD655 (E) or 2SD655 (F)
Q253	2211454	2SA1015 (Y)
Q254-Q258	2211255 or 2210746	2SC1815 (GR) or 2SC945A (P)
Q260, Q261	2211255, 2210746 or 2212485	2SC1815 (GR), 2SC945A (P) or JC501 (Q)
Diode		
D251	2239592 or 2243212	RD10EB2 or MTZ10B
Capacitors		
C251-C256	352741009	10 μ F, 16V, Elect.
C257-C259	352724719	470 μ F, 6.3V, Elect.
Socket		
	25050268	NSCT-4P96
Terminals		
P251, P252	25045178	NPJ-3PDBL68
Switch		
S730	25065242	NSS-22104, Slide

CIRCUIT NO.	PART NO.	DESCRIPTION	CIRCUIT NO.	PART NO.	DESCRIPTION
	ICs			Capacitors	
Q701, Q702	222741451	74LS145	C701	352784799	0.47 μ F, 50V, Elect.
Q703, Q708	222930	TD62551S	C702	352742209	22 μ F, 16V, Elect.
Q709	222619	μ PB553AC	C703	3020018	0.047F, 5V, Super
Q710	222932	μ PD1712CU-527	C707	352721019	100 μ F, 6.3V, Elect.
Q718	222770	μ PD6320G	C708	352784799	0.47 μ F, 50V, Elect.
Q720	222930	TD62551S	C710, C712	352723319	330 μ F, 6.3V, Elect.
	Transistors		C714	352741009	10 μ F, 16V, Elect.
Q704-Q706	2211255,	2SC1815 (GR),	C715	352780109	1 μ F, 50V, Elect.
Q712	2210746 or	2SC945A (P) or	C726	352742209	22 μ F, 16V, Elect.
Q715-Q717	2212485	JC501 (Q)		Resistors	
Q707	2211705 or	2SD655 (E) or	R721-R728	49163103408	10k Ω x8, 1/10W, Network
	2211706	2SD655 (F)	R730-R733	49163103404	10k Ω x4, 1/10W, Network
Q731	2211256	2SC1815 (BL)	R736-R739	49163104404	100k Ω x4, 1/10W, Network
	Fluorescent indicator tube			Sockets	
Q719	212023	FIP7F8S		25050267	NSCT-3P95
	Diodes			25050268	NSCT-4P96
D701, D702	223150,	US1040,		25050270	NSCT-6P98
D704-D707	223145 or	1S2076TD or		25050273	NSCT-9P101
D713, D714	223124	1S2473		Plugs	
D718				25055133	NPLG-3P-177
D703	2239452	RD5.1EB2		25055137	NPLG-7P-121
D715	2241291	RD3.3EB1		Bracket	
D719	223848	GP08B		27141039	Fluorescent tube
	X'tal				
X701	3010052	XTL4.5M			
	Buzzer				
X702	241048	PKM24-4A0			

DISPLAY CIRCUIT PC BOARD (NADIS-2475-1)

CIRCUIT NO.	PART NO.	DESCRIPTION
	L. E. Ds	
D732	225142	SEL2913K
D733, D740	225137CG, 225137DG or 225137DY	SEL2413ECG, SEL2413EDG or SEL2413EDY
D734-D739	225142	SEL2913K
	Resistor	
R762-R769	49121221508	220 Ω ×8, 1/8W, Network
	Holder	
	27190413	LED 9

DIAL PLATE ILLUMINATION PC BOARD (NAPL-2477-1)

CIRCUIT NO.	PART NO.	DESCRIPTION
PL701	210064A	PL6.3V, 250mA, Lamp

REMOTE CONTROL RECEIVER CIRCUIT PC BOARD (NADG-2476-1)

CIRCUIT NO.	PART NO.	DESCRIPTION
	241060	HRS-0091, Receiver unit
D731	225137CG, 225137DG or 225137DY	SEL2413E-CG, SEL2413E-DG or SEL2413E-DY, L. E. D.
	27190412	Holder, LED

PRINTED CIRCUIT BOARD-PARTS LIST

VOLUME AND TONE CONTROL CIRCUIT PC BOARD (NATC-2479-1)

CIRCUIT NO.	PART NO.	DESCRIPTION
	ICs	
Q313	222928	TC9177P
Q314, Q414	222502	NJM4558DX
Q315, Q415	222534	NJM4559DX
	Capacitors	
C350, C450	352780229	2.2 μ F, 50V, Elect.
C353, C453	352780229	2.2 μ F, 50V, Elect.
C354, C454	352742209	22 μ F, 16V, Elect.
C355, C455	352780109	1 μ F, 50V, Elect.
C356, C357	352744709	47 μ F, 16V, Elect.
C361, C461	352780109	1 μ F, 50V, Elect.
C362, C462	352742209	22 μ F, 16V, Elect.
C367, C368	352780339	3.3 μ F, 50V, Elect.
	Resistors	
R381	6142048	N30LLC250KWT10Z
R391, R491	6142050	N30LGLC250KC10Z
R395, R495	6142050	N30LGLC250KC10Z

POWER SUPPLY CIRCUIT PC BOARD (NAPS-2480-1)

CIRCUIT NO.	PART NO.	DESCRIPTION
	Transistors	
Q891	2211256	2SC1815 (BL)
Q905	2201404 or 2201405	2SD1406 (Y) or 2SD1406 (GR)
	Diodes	
D891	223145, 223150 or 223124	1S2076TD, US1040 or 1S2473
D911	223890 or 223862	W01RL or WL01
D912	223896 or 223880	1N4003F or GP101N4003
D913	2239493	RD6.2EB3
	Capacitors	
C901, C902	3500065A Δ	DE7150FZ103PAC400/125V, IS
C922, C924	352741019	100 μ F, 16V, Elect.
C923	352742229	2,200 μ F, 16V, Elect.
C925	352733319	330 μ F, 10V, Elect.
C926	352724719	470 μ F, 6.3V, Elect.

	Resistors	
R901	431523355 Δ	3.3M Ω , 1/2W, Solid
R911	441520104	1 Ω , 1/2W, Metal oxide film
R912	441623314	330 Ω , 1W, Metal oxide film
R913	441620474	4.7 Ω , 1W, Metal oxide film
	Switch	
S901	25035398 Δ	NPS-111-L362P
	Relay	
RL891	25065269	NRL-1P5A-DC12-36
	Fuseholders	
F901	250113 Δ	SN5051
	Fuse	
F901	252049 Δ	4A (ST-6)

SPEAKER SWITCH PC BOARD (NASW-2481-1)

CIRCUIT NO.	PART NO.	DESCRIPTION
R518, R618	441623914	390 Ω , 1W, Metal oxide film resistor
S501-S503	25035498	NPS-222-162-L460, Push switch
S903	25035500	NPS-111-S462, Push switch
P502	25045187	HLJ-0541-01-010, Stereo headphone terminal

SPEAKER TERMINAL PC BOARD (NATRM-2482-1)

CIRCUIT NO.	PART NO.	DESCRIPTION
P501	25060093	NTM-8PDML34, Speaker terminal

MATRIX CIRCUIT PC BOARD (NAMR-2483-1)

CIRCUIT NO.	PART NO.	DESCRIPTION
L502	CC204	CC-204, Choke coil

PRINTED CIRCUIT BOARD VIEW FROM BOTTOM SIDE

DISPLAY CIRCUIT PC BOARD (NADIS-2474-1)

CIRCUIT NO.	PART NO.	DESCRIPTION
ICs		
Q721	222929	TC9185P
Q725	222931	μ PC393C
Transistors		
Q722-Q724	2211255,	2SC1815 (GR),
Q726, Q727	2210746 or	2SC945A (P) or
	2212485	JC501 (Q)
Q728-Q730	2212600 or	DTA124ES or
	221243	2SA1346
Diodes		
D721, D722	223150,	US1040,
D725	223145 or	1S2076TD or
	223124	1S2473
D726, D727	223150 or	US1040 or
	223124	1S2473
D723, D724	223155	1SS138
L. E. Ds		
D741-D744	225206C or	SEL2910D-C or
D748-D755	225206D	SEL2910D-D
D745-D747	225142	SEL2913K
D756-D771	225137CG,	SEL2413ECG,
	225137DG or	SEL2413EDG or
	225137DY	SEL2413EDY
Capacitors		
C719	352722219	220 μ F, 6.3V, Elect.
C722	353744709	47 μ F, 16V, Elect.
C724	352741009	10 μ F, 16V, Elect.
Switches		
S702-S729	25035389	NPS-111-S353, Push
Socket		
	25050254	NSCT-3P82
Spacers		
	27270172	LED 10
	27270173	LED 12
Holder		
	27190415	LED R

SYSTEM CONNECTION DIAGRAM

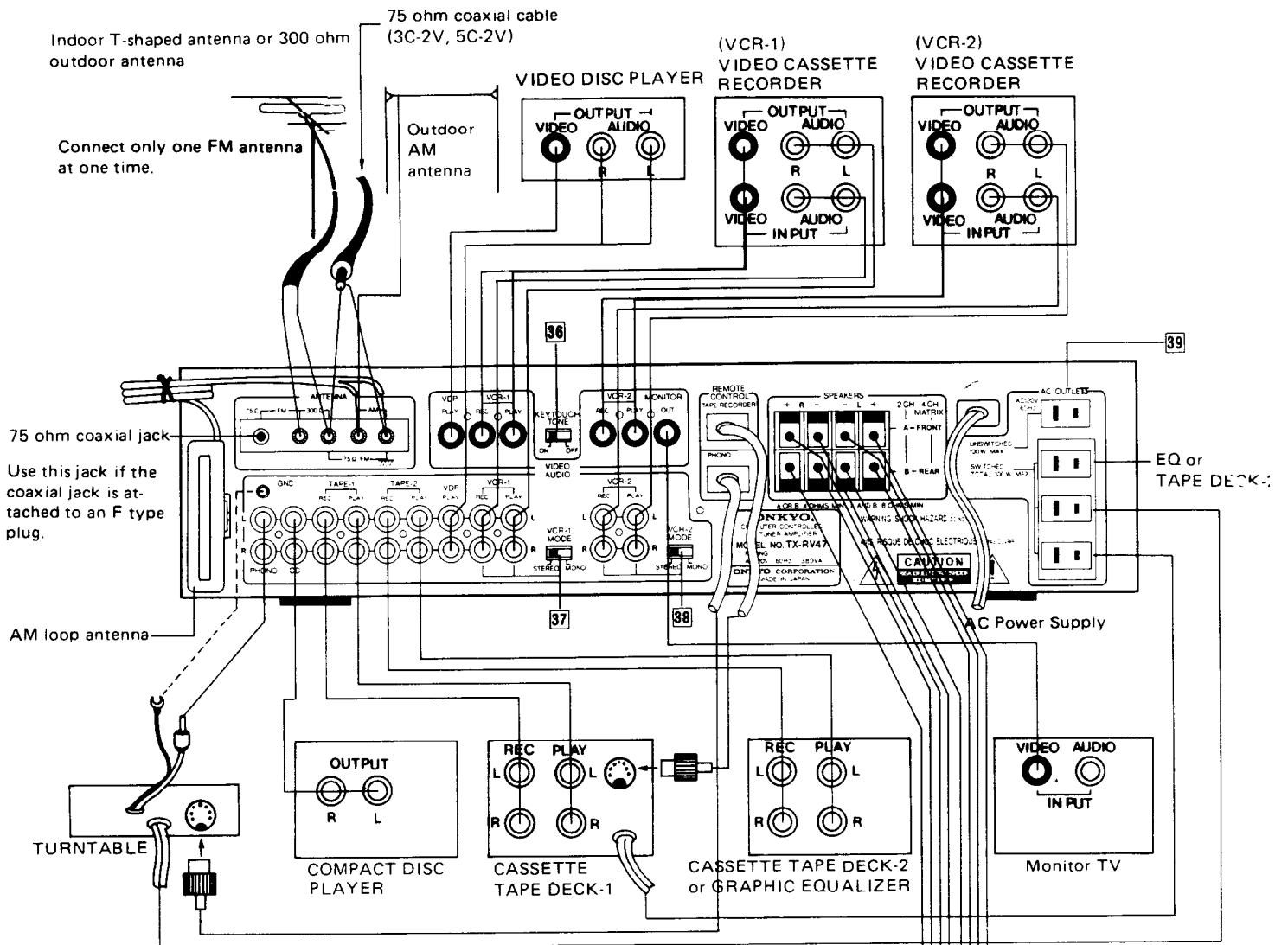

Note: Remote control operation of a cassette deck (or turntable) is not possible when only the remote control DIN cable is connected. The in and out pin cables for the signal must also be connected before remote control operation functions. Be sure that both cables are firmly inserted before using the cassette deck (or turntable) remote control function.

Compatible Onkyo Remote Control Cassette Decks

TA-2047	TA-2036
TA-2090 (3-head)	TA-2044
TA-2056 (3-head)	TA-2033

Compatible Onkyo Remote Control Turntables

CP-1057F	CP-1044F
CP-1055F II	CP-1055F
CP-1046F	⋮

PACKING VIEW

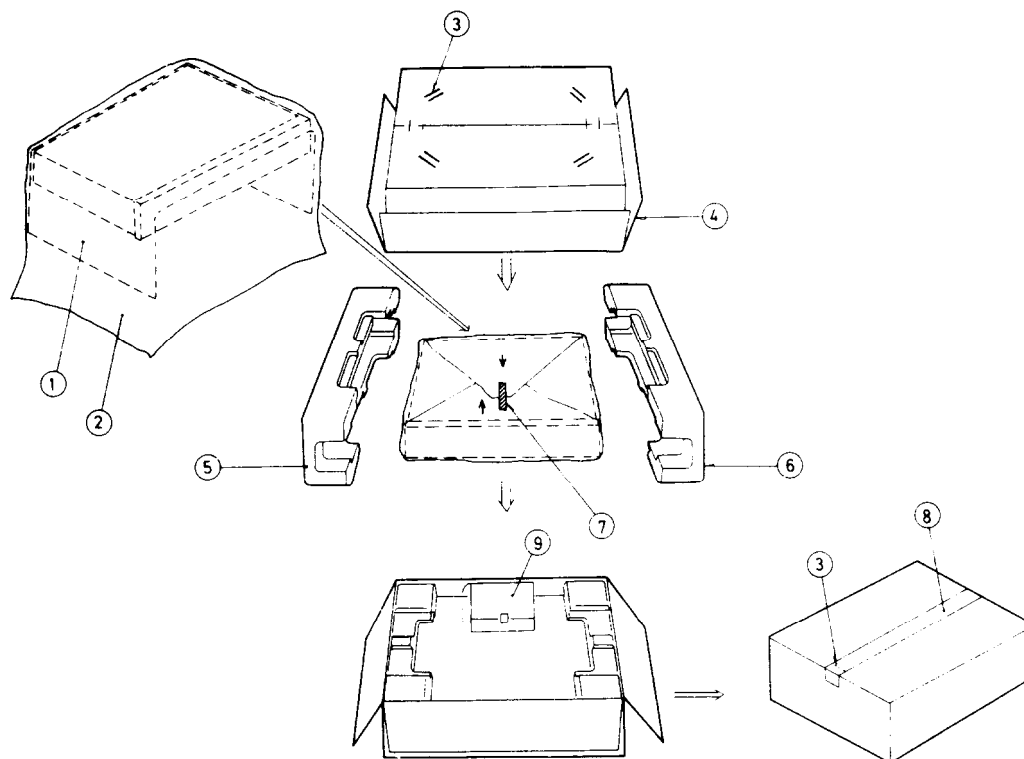

REF. NO.	PART NO.	DESCRIPTION
1	29095108-1	1000×600mm, Protection sheet
2	29100035A	1020×720mm, Poly-vinyl bag
3	282301	Sealing hook
4	29051226	Master carton box
5	29091046A	Pad R
6	29091045A	Pad L
7	261504	30×400mm, Adhesive tape
8	260012	50×700mm, Damp-Proof tape
9		Accessory bag complete
	29340953	Instruction manual
	292064A	FM antenna
	241059	Remote control unit
	3010054	UM-3, Two batteries
	29365006-7	Warranty card
	29358002C	Service station list
	29100006A	350×250, Poly-vinyl bag

ONKYO CORPORATION

International Division: No. 24 Mori Bldg., 23-5, 3-chome, Nishi-Shinbashi, Minato-ku, Tokyo, Japan

Telex: 2423551 ONKYO J. Phone: 03-432-6981

ONKYO U.S.A. CORPORATION

200 Williams Drive, Ramsey, N.J. 07446 Tel. 201-825-7950

A510 printed in japan