

ONKYO SERVICE MANUAL

AV RECEIVER MODEL TX-SR500/E

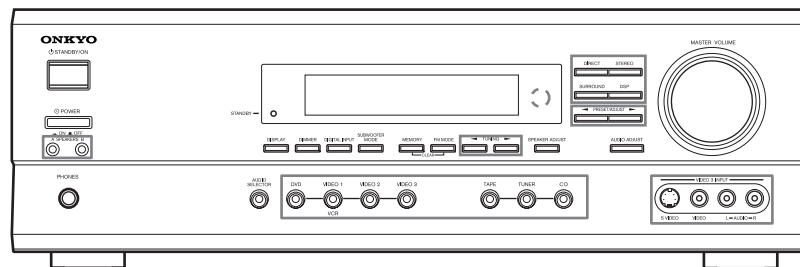

Black, Golden and Silver models

BMDD,BMDC	120V AC, 60Hz
BMPP,SMPP,BMPA,GMPA	230-240V AC, 50Hz
BMWT,GMWT,GMWR,GMWQ	120/220-230V AC, 50/60Hz
GMGK	220V AC, 50Hz

SAFETY-RELATED COMPONENT WARNING!!

COMPONENTS IDENTIFIED BY MARK \triangle ON THE SCHEMATIC DIAGRAM AND IN THE PARTS LIST ARE CRITICAL FOR RISK OF FIRE AND ELECTRIC SHOCK. REPLACE THESE COMPONENTS WITH ONKYO PARTS WHOSE PART NUMBERS APPEAR AS SHOWN IN THIS MANUAL.

MAKE LEAKAGE-CURRENT OR RESISTANCE MEASUREMENTS TO DETERMINE THAT EXPOSED PARTS ARE ACCEPTABLY INSULATED FROM THE SUPPLY CIRCUIT BEFORE RETURNING THE APPLIANCE TO THE CUSTOMER.

SPECIFICATIONS

AMPLIFIER SECTION

Continuous Average Power output (FTC)	
All channels:	65 watts per channel min. RMS at 8 ohms, 2 channels driven from 20 Hz to 20 kHz with no more than 0.08% total harmonic distortion.
Continuous Power output (DIN)	85 watts×5 at 6 ohms
Maximum Power output (EIAJ)	115 watts×5 at 6 ohms
Dynamic power output:	160 watts×2 at 3 ohms 125 watts×2 at 4 ohms 85 watts×2 at 8 ohms
Total Harmonic Distortion:	0.08% at rated power 0.08% at 1 watt output
IM Distortion:	0.08% at rated power 0.08% at 1 watt output
Damping Factor:	60 at 8 ohms
Input Sensitivity and Impedance	
DIGITAL INPUT (OPTICAL 1, 2):	0.5 Vp-p, 75 ohms
DIGITAL INPUT (COAXIAL):	0.5 Vp-p, 75 ohms
LINE (CD, VIDEO 1, 2, 3, TAPE):	200 mV, 50 kohms
Multichannel Input	
(DVD FRONT L/C/R, SURR L/R):	200 mV, 50 kohms
(SUBWOOFER):	36 mV, 50 kohms
Output Level and Impedance	
Rec out (TAPE, VIDEO 1):	200 mV, 470 ohms
Pre out (SUBWOOFER):	1 V, 470 ohms
Frequency Response:	10 Hz to 10 kHz, +1/-3 dB (Direct mode)
Tone Control	
Bass:	±12 dB at 50 Hz
Treble:	±12 dB at 20 kHz
Signal-to-Noise Ratio:	CD/TAPE: 100 dB (IHF-A, Direct mode)
Muting:	-50 dB

VIDEO SECTION

Input Sensitivity and Impedance	
VIDEO (DVD, VIDEO 1, 2, 3):	1 Vp-p, 75 ohms
S VIDEO (DVD, VIDEO 1, 2, 3):	1 Vp-p, 75 ohms (Y) 0.28 Vp-p, 75 ohms (C)
Output Level and Impedance	
VIDEO (VIDEO 1, 2, MONITOR):	1 Vp-p, 75 ohms
S VIDEO (VIDEO 1, 2, MONITOR):	1 Vp-p, 75 ohms (Y) 0.28 Vp-p, 75 ohms (C)

TUNER SECTION

FM	
Tuning Range:	87.5-108.0 MHz (50 kHz steps)
Usable Sensitivity	
Mono:	11.2 dBf, 1.0 μV (75 ohms, IHF) 11.2 dBf, 0.9 μV (75 ohms, DIN)
Stereo:	17.2 dBf, 2.0 μV (75 ohms, IHF) 17.2 dBf, 23 μV (75 ohms DIN)

50 dB Quieting Sensitivity	
Mono:	17.2 dBf, 2.0 μV (75 ohms)
Stereo:	37.2 dBf, 20.0 μV (75 ohms)
Capture Ratio:	2.0 dB
Image Rejection Ratio	
North American models:	40 dB
Other models:	85 dB
IF Rejection Ratio:	90 dB
Signal-to-Noise Ratio	
Mono:	76 dB, IHF
Stereo:	70 dB, IHF
Alternate Channel Attenuation:	55 dB, IHF, ±400 kHz
Selectivity:	50 dB (DIN)
AM Suppression Ratio:	50 dB
Total Harmonic Distortion	
Mono:	0.2%
Stereo:	0.3%
Frequency Response:	30 Hz-15 kHz, ±1.0 dB
Stereo Separation:	45 dB at 1 kHz 30 dB at 100 Hz-10 kHz

AM

Tuning Range	
North American models:	530-1,710 kHz (10 kHz steps)
European & Australian models:	522-1,611 kHz (9 kHz steps)
Worldwide models:	531-1,602 kHz (9 kHz steps), 530-1,710 kHz (10 kHz steps)
Usable Sensitivity:	30 μV
Image Rejection Ratio:	40 dB
IF Rejection Ratio:	40 dB
Signal-to-Noise Ratio:	40 dB
Total Harmonic Distortion:	0.7%

GENERAL

Power Supply and	AC 120 V, 60 Hz	4.0 A
Power Consumption:	AC 230-240 V, 50 Hz	320 W
	AC 220-230 V and 120 V	switchable, 50/60 Hz 320 W
Dimensions (W×H×D):	17-1/8" × 5-7/8" × 14-13/16" 435 × 150 × 376 mm	
Weight		
North American models:	18.7 lbs., 8.5 kg	
Other models:	19.4 lbs., 8.8 kg	

REMOTE CONTROL

Transmitter:	Infrared
Signal range:	Approx. 16 ft., 5 meters
Power supply:	Two "AA" batteries (1.5 V × 2)

Specifications and features are subject to change without notice. Power supply and voltage vary depending on the area in which the unit is purchased.

SERVICE PROCEDURES

1. Replacing the fuses

 This symbol located near the fuses indicates that the fuse used is fast operating type. For continued protection against fire hazard, replace with same type fuse. For fuse rating refer to the marking adjacent to the symbol.

 Ce symbole indique que le fusible utilise est a rapide. Pour une protection permanente, n'utiliser que fusibles de meme type. Ce dernier est la qu le present symbol est appe.

CIRCUIT NO.	PART NO.	DESCRIPTION
F6901,	252198 or	8A-UL or
F6902	252261	8A-T/UL-ST2,Fuse <D>
	252099	8A-EAK,Fuse <O>
F901	252166 or	6.3A-UL/T-237 or
	252260	6.3A-T/UL-ST2,Fuse <D/T/A/R/Q>
F902	252076 or	3.15A-SE-EAK or
	252242	3.15A-SE-TL250V,Fuse <O>
F903	252075 or	2.5A-SE-EAK or
	252241	2.5A-SE-TL250V,Fuse <O>

Note: <D>:120V model only
 <O>: Other models except 120V model
 <T>: Asian model only for 230V
 <R>: Chinese model only
 <Q>: Hongkong model only
 <A>: Australian model only

2. To initialize the unit

This device employs a microprocessor to perform various functions and operations. If interference generated by an external power supply, radio wave, or other electrical source results in accident which causes the specified operations and functions to operate abnormally.

To perform a result, please follow the procedure below.

- 1.Press and hold down the VIDEO-1 button, then press the STANDBY/ON button.
- 2.After "clear" is displayed, the preset memory and each mode stored in the memory, such as surround, are initialized and will return to the factory setting.

3. Safety-check out

(Only U.S.A. model)

After correcting the original service problem, perform the following safety check before releasing the set to the customer. Connect the insulating-resistance tester between the plug of power supply cord and screw on the back panel. Specifications: 3.3Mohm+/-10% at 500V.

4. Memory Preservation

This unit does not require memory preservation batteries. A built-in memory power back-up system preserves the contents of the memory during power failures and even when the unit is unplugged.The unit must be plugged in order to charge the back-up system.

The memory preservation period after the unit has been unplugged varies depending on climate and placement of the unit. On the average, memory contents are protected over a period of a few weeks after the last time the unit has been unplugged.This period is shorter when the unit is exposed to a highly humid climate.

5.Setting the voltage selector (Worldwide models only)

Worldwide models are equipped with a voltage selector to conform with local power supplies. Be sure to set this switch to match the voltage of the power supply in your area before plugging in the unit.

Determine the proper voltage for your area: 220-230 V or 120 V. If the preset voltage is not correct for your area, insert a screwdriver into the groove in the switch. Slide the switch all the way to the upper (120 V) or to the lower (220-230 V), whichever is appropriate.

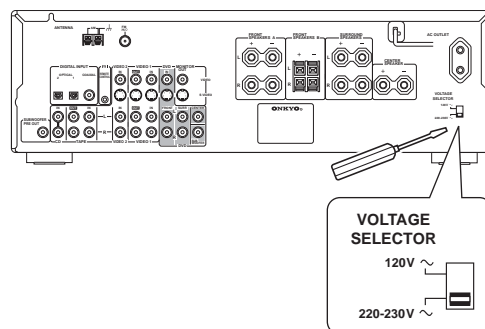

6.Setting the AM tuning step frequency

(Worldwide models only)

You can switch the AM band tuning steps between 9 kHz and 10 kHz.

The initial setting is 9 kHz. Please set the AM tuning step frequency to match the AM band tuning step frequency in your area.

USA and Canadian models 10 kHz

Other models 9 kHz

Press MEMORY while holding down TUNER.

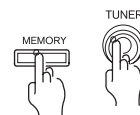



Note



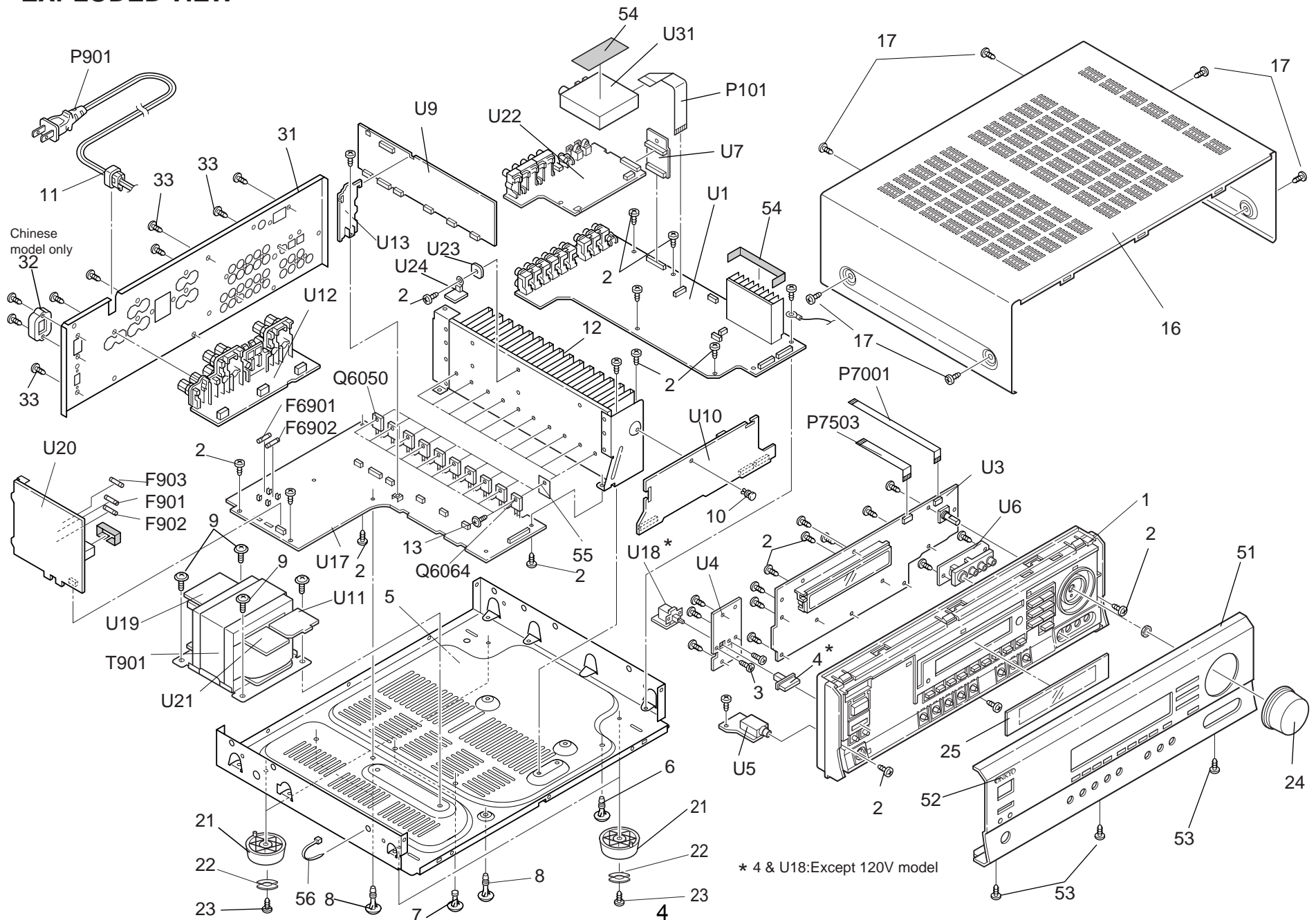











All the preset stations are erased when you switch the AM band tuning steps.

EXPLODED VIEW



EXPLODED VIEW-PARTS LIST

REF.NO.	PART NO.	DESCRIPTION
1	27111268	Front bracket
	27111269	Front bracket <S>
	27111270	Front bracket <G>
2	838130088	3TTB+8B,Self-tapping screw
3	82143010	3P+10FN(BC),Pan head screw
4	28325497A	Knob,power
	28325499A	Knob, power <G>
	28325547A	Knob, power <S>
5	27100416	Chassis
6	27190503A	KGLS-8RF,Holder
7	27190813	KGPS-10RF,Holder
8	27190428A	KGLS-10RF,Holder
9	830440089	4TTC+8C(BC),Self-tapping screw
10	880009	NRP-345,Plastic rivet
11	27300750	 Bushing, cord
12	27160501	Heat sink
13	801433	3SMS8W.SW+14B(BC),Special screw
16	28184831	Top cover
	28184833	Top cover <S>
	28184834	Top cover <G>
17	838430088	3TTB+8B(BC),Self-tapping screw
	838930088	3TTB+8B(UN),Self-tapping screw <G/S>
21	27175319B	Leg
22	28141494	Cushion
23	838130088	3TTB+8B,Self-tapping screw
24	28325641	Knob, volume
	28325642	Knob, volume <S>
	28325643	Knob, volume <G>
25	28191957	Clear plate
	28191958	Clear plate <G/S>
31	27122953A	Rear panel <D>
	27122954A	Rear panel <P>
	27122955A	Rear panel <K>
	27122956A	Rear panel <T/Q>
	27122957B	Rear panel <R>
	27122958A	Rear panel <A>
32	27191143	 Holder,outlet <R>
33	838430088	3TTB+8B(BC),Self-tapping screw

REF.NO.	PART NO.	DESCRIPTION
51	27212368	Front panel <D>
	27212369	Front panel <P>
	27212370	Front panel <S>
	27212371	Front panel <A/T>
	27212372	Front panel <G>
52	28135244	Badge
	28135245	Badge <G/S>
53	838430088	3TTB+8B(BC),Self-tapping screw
54	29110111	Cloth tape
55	223024	AC238,Isolated plate
56	260208	Wire tie
F6901,	252198 or	8A-UL or
F6902	252261	8A-T/UL-ST2,Fuse <D>
	252099	8A-EAK,Fuse <O>
F901	252166 or	 6.3A-UL/T-237 or
	252260	 6.3A-T/UL-ST2,Fuse <D/T/A/R/Q>
F902	252076 or	 3.15A-SE-EAK or
	252242	 3.15A-SE-TL250V,Fuse <O>
F903	252075 or	 2.5A-SE-EAK or
	252241	 2.5A-SE-TL250V,Fuse <O>
P101	2047151512	NCFC7-151512,Flexible flat cable
P7001	2045102012	NCFC5-102012,Flexible flat cable
P7503	2047081012	NCFC7-081012,Flexible flat cable
P901	253332HIT or	 AS-UC-2 or
	253333VOL	 AS-UC-2,Power supply cord <D>
	253197HIT	 AS-SAA,Power supply cord <A>
	253233KAW	 AS-CEE-2,Power supply cord <P/T/K>
	253198HIT	 AS-BS,Power supply cord <Q>
	253337HIT or	 AS-CCEE or
	253338VOL	 AS-CCEE,Power supply cord <R>
P902A	25052665	 NSCT-2P2561,AC outlet <K>
Q6050~	2203633,	* KTD1047-O,
Q6054	2203634,	* KTD1047-Y,
	2203653,	* MN100S-O,
	2203654 or	* MN100S-Y or
	2203656	* MN100S-P,Transistor
Q6060~	2203623,	* KTB817-O,
Q6064	2203624,	* KTB817-Y,
	2203643,	* MP100S-O,
	2203644 or	* MP100S-Y or
	2203646	* MP100S-P,Transistor



NOTE: THE COMPONENTS IDENTIFIED BY MARK  ARE CRITICAL FOR RISK OF FIRE AND ELECTRIC SHOCK. REPLACE ONLY WITH PART NUMBER SPECIFIED.

CAUTION: Replacement for transistor of mark *, if necessary must be made from the same beta group (Hfe) as the original type.

Note:

: Black model only
 <G>: Golden model only
 <S>: Silver model only
 <D>: 120V model only
 <T>: Worldwide model only
 <P>: European model only
 <K>: Korean model only
 <A>: Australian model only
 <R>: Chinese model only
 <Q>: Hongkong model only
 <O>: Except 120V model

EXPLODED VIEW-PARTS LIST

REF.NO.	PART NO.	DESCRIPTION	REF.NO.	PART NO.	DESCRIPTION
T901	2301577	 NPT-1436D,Power transformer <D>	U19	1A928519-1A	NAPS-7419-1A,Terminal PC board ass'y <D>
	2301578	 NPT-1436P,Power transformer <P/A>		1A928519-1B	NAPS-7419-1B,Terminal PC board ass'y <P>
	2301579	 NPT-1436DG,Power transformer <T/R/Q/K>		1A928519-1C	NAPS-7419-1C,Terminal PC board ass'y <A>
U1	1A928501-1A	NADG-7401-1A,DSP circuit PC board ass'y <D>		1A928519-1D	NAPS-7419-1D,Terminal PC board ass'y <R>
	1A928501-1B	NADG-7401-1B,DSP circuit PC board ass'y <P>		1A928519-1E	NAPS-7419-1E,Terminal PC board ass'y <T/Q>
	1A928501-1C	NADG-7401-1C,DSP circuit PC board ass'y <A/K>		1A928519-1F	NAPS-7419-1F,Terminal PC board ass'y <K>
	1A928501-1D	NADG-7401-1D,DSP circuit PC board ass'y <T/R/Q>	U20	1A928520-1A	NAPS-7420-1A,Primary circuit PC board ass'y <D>
U3	1A928503-1A	NADIS-7403-1A,Display circuit PC board ass'y <D>		1A928520-1B	NAPS-7420-1B,Primary circuit PC board ass'y <P>
	1A928503-1B	NADIS-7403-1B,Display circuit PC board ass'y <O>		1A928520-1C	NAPS-7420-1C,Primary circuit PC board ass'y <A>
U4	1A928504-1A	NASW-7404-1A,Standby switch PC board ass'y <D>		1A928520-1D	NAPS-7420-1D,Primary circuit PC board ass'y <R>
	1A928504-1B	NASW-7404-1B,Standby switch PC board ass'y <O>		1A928520-1E	NAPS-7420-1E,Primary circuit PC board ass'y <T/Q>
U5	1A928505-1A	NAETC-7405-1A,Headphone terminal PC board ass'y <D>	U21	1A928521-1A	NAPS-7421-1A,Terminal PC board ass'y <D>
	1A928505-1B	NAETC-7405-1B,Headphone terminal PC board ass'y <O>		1A928521-1B	NAPS-7421-1B,Terminal PC board ass'y <P>
U6	1A928506-1A	NAETC-7406-1A,Front video PC board ass'y <D>		1A928521-1C	NAPS-7421-1C,Terminal PC board ass'y <A>
	1A928506-1B	NAETC-7406-1B,Front video PC board ass'y <O>		1A928521-1D	NAPS-7421-1D,Terminal PC board ass'y <R>
U7	1A928507-1A	NAETC-7407-1A,Connector PC board ass'y <D>		1A928521-1E	NAPS-7421-1E,Terminal PC board ass'y <T/Q>
	1A928507-1B	NAETC-7407-1B,Connector PC board ass'y <O>		1A928521-1F	NAPS-7421-1F,Terminal PC board ass'y <K>
U9	1A928509-1A	NAAF-7409-1A, Power amplifier driver PC board ass'y <D>	U22	1A928522-1A	NAVD-7422-1A,Video terminal PC board ass'y <D>
	1A928509-1B	NAAF-7409-1B, Power amplifier driver PC board ass'y <O>		1A928522-1B	NAVD-7422-1B,Video terminal PC board ass'y <P>
U10	1A928510-1A	NAETC-7410-1A,Regulator PC board ass'y <D>		1A928522-1C	NAVD-7422-1C,Video terminal PC board ass'y <A>
	1A928510-1B	NAETC-7410-1B,Regulator PC board ass'y <O>		1A928522-1D	NAVD-7422-1D,Video terminal PC board ass'y <R>
U11	1A928511-1A	NAETC-7411-1A,Secondary circuit PC board ass'y <D>		1A928522-1E	NAVD-7422-1E,Video terminal PC board ass'y <T/Q>
	1A928511-1B	NAETC-7411-1B,Secondary circuit PC board ass'y <O>		1A928522-1F	NAVD-7422-1F,Video terminal PC board ass'y <K>
U12	1A928512-1A	NAETC-7412-1A,Speaker terminal PC board ass'y <D>	U23	1A928523-1A	NAETC-7423-1A,PC board for holder <D>
	1A928512-1B	NAETC-7412-1B,Speaker terminal PC board ass'y <O>		1A928523-1B	NAETC-7423-1B,PC board for holder <P>
U13	1A928513-1A	NAETC-7413-1A,PC board for holder <D>		1A928523-1C	NAETC-7423-1C,PC board for holder <A>
	1A928513-1B	NAETC-7413-1B,PC board for holder <O>		1A928523-1D	NAETC-7423-1D,PC board for holder <R>
U17	1A928517-1A	NAAF-7417-1A,Power amplifier PC board ass'y <D>		1A928523-1E	NAETC-7423-1E,PC board for holder <T/Q>
	1A928517-1B	NAAF-7417-1B,Power amplifier PC board ass'y <P>	U24	1A928524-1A	NAETC-7424-1A,Thermal detector circuit PC board ass'y <D>
	1A928517-1C	NAAF-7417-1C,Power amplifier PC board ass'y <A>		1A928524-1B	NAETC-7424-1B,Thermal detector circuit PC board ass'y <P>
	1A928517-1D	NAAF-7417-1D,Power amplifier PC board ass'y <R>		1A928524-1C	NAETC-7424-1C,Thermal detector circuit PC board ass'y <A>
	1A928517-1E	NAAF-7417-1E,Power amplifier PC board ass'y <T/Q>		1A928524-1D	NAETC-7424-1D,Thermal detector circuit PC board ass'y <R>
	1A928517-1F	NAAF-7417-1F,Power amplifier PC board ass'y <K>		1A928524-1E	NAETC-7424-1E,Thermal detector circuit PC board ass'y <T/Q>
U18	1A928518-1B	NASW-7418-1B,Power switch PC board ass'y <P>		1A928524-1F	NAETC-7424-1F,Thermal detector circuit PC board ass'y <K>
	1A928518-1C	NASW-7418-1C,Power switch PC board ass'y <A>	U25	1A928525-1F	NAETC-7425-1F,PC board ass'y <K>
	1A928518-1D	NASW-7418-1D,Power switch PC board ass'y <R>	U31	240134A	TFCE1U114B,Tuner unit <D>
	1A928518-1E	NASW-7418-1E,Power switch PC board ass'y <T/Q>		240135,	TFCE1E512A,
	1A928518-1F	NASW-7418-1F,Power switch PC board ass'y <K>		240138A or	ENG06501QR or
				240139A	ENG07501QR,Tuner unit <O>

Note:

: Black model only
 <G>: Golden model only
 <S>: Silver model only
 <D>: 120V model only
 <P>: European model only
 <T>: Worldwide model only
 <K>: Korean model only
 <A>: Australian model only
 <R>: Chinese model only
 <C>: Canadian model only
 <Q>: Hongkong model only
 <O>: Except 120V model

NOTE: THE COMPONENTS IDENTIFIED BY MARK  ARE CRITICAL FOR RISK OF FIRE AND ELECTRIC SHOCK. REPLACE ONLY WITH PART NUMBER SPECIFIED.

BLOCK DIAGRAM 1

1
2
3
4
5

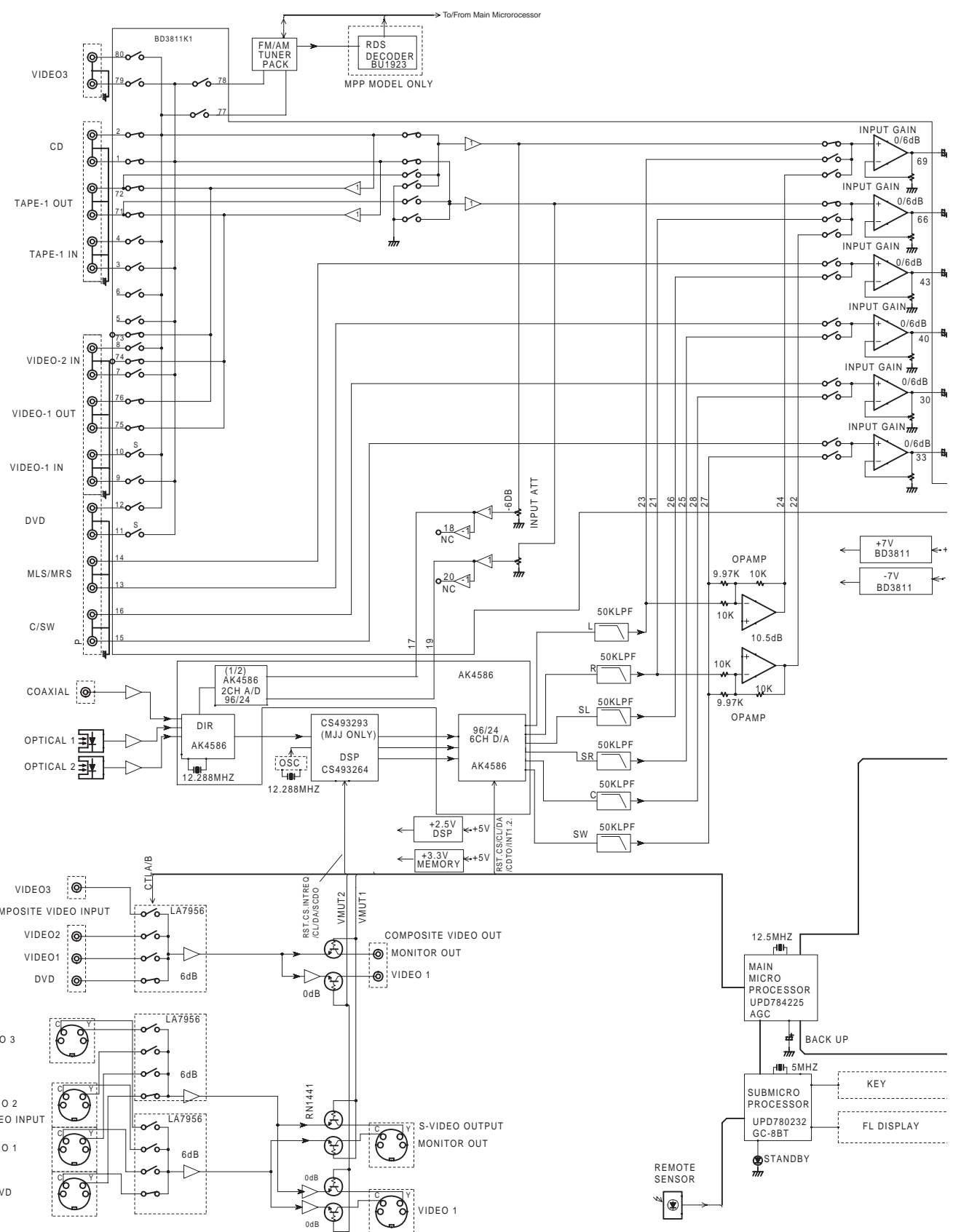

A B C D

BLOCK DIAGRAM 2

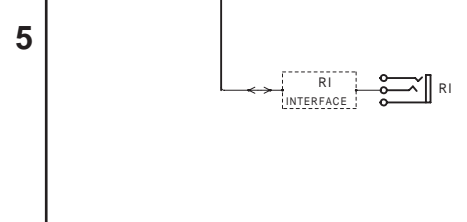
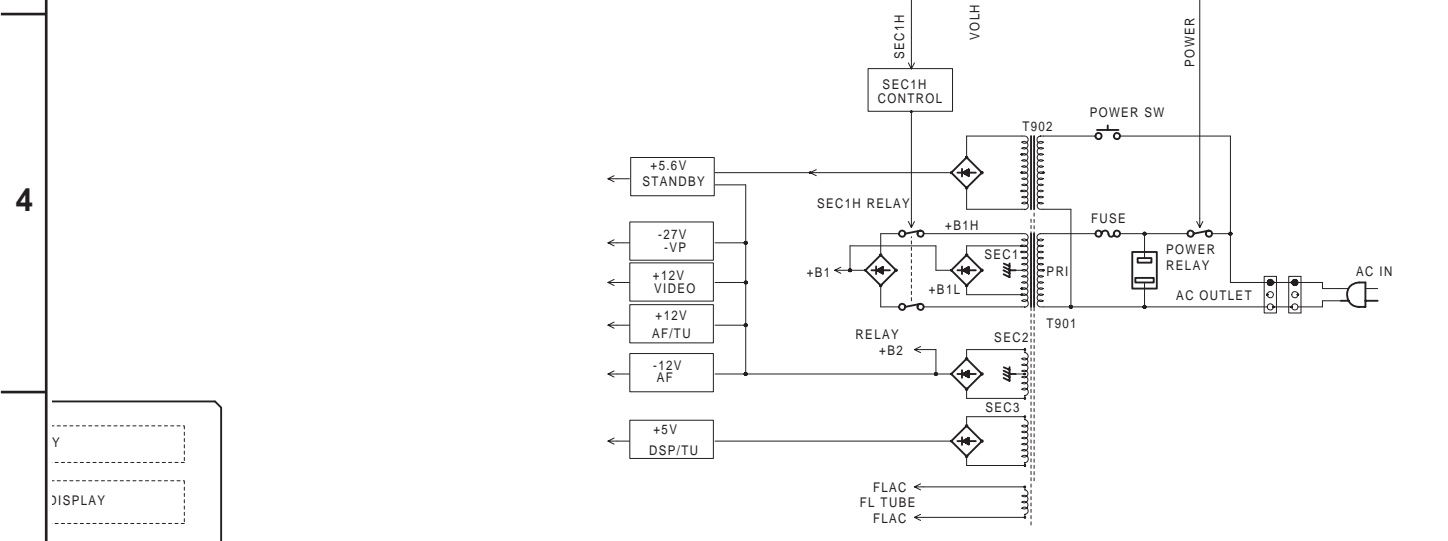
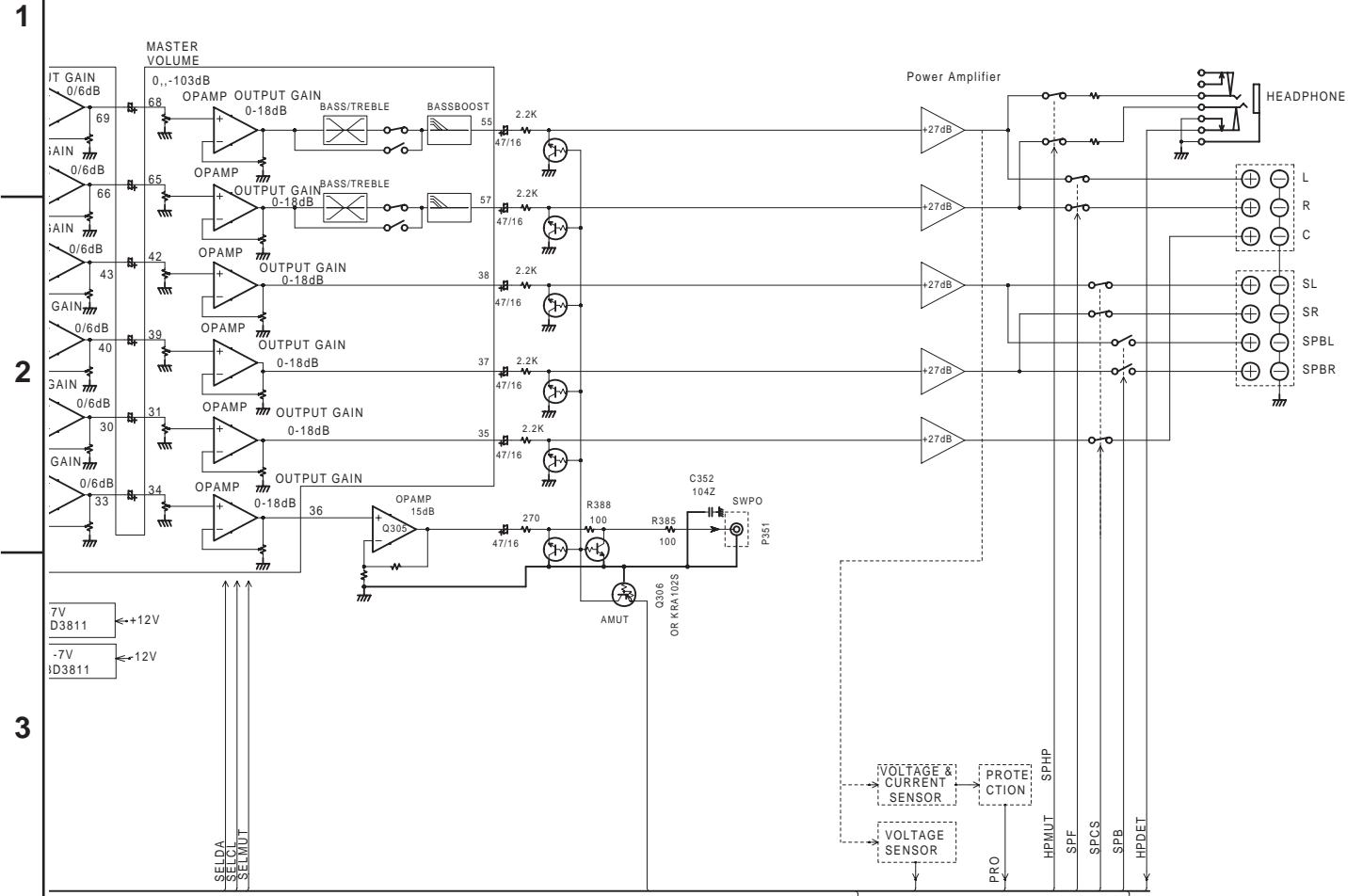

SCHEMATIC DIAGRAM 1 DISPLAY SECTION

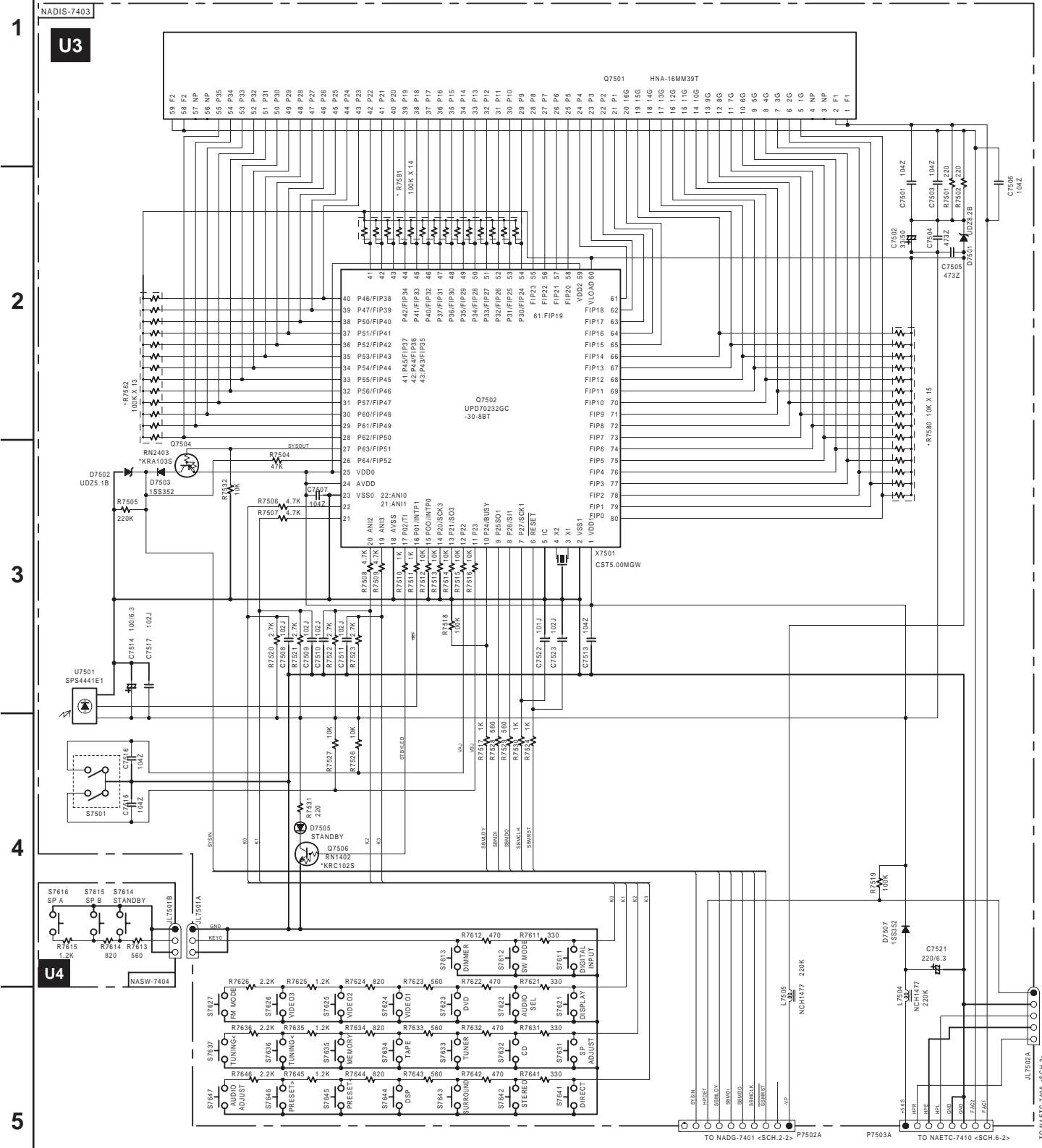

A B C D

SCHEMATIC DIAGRAM 2-1 -DSP SECTION-

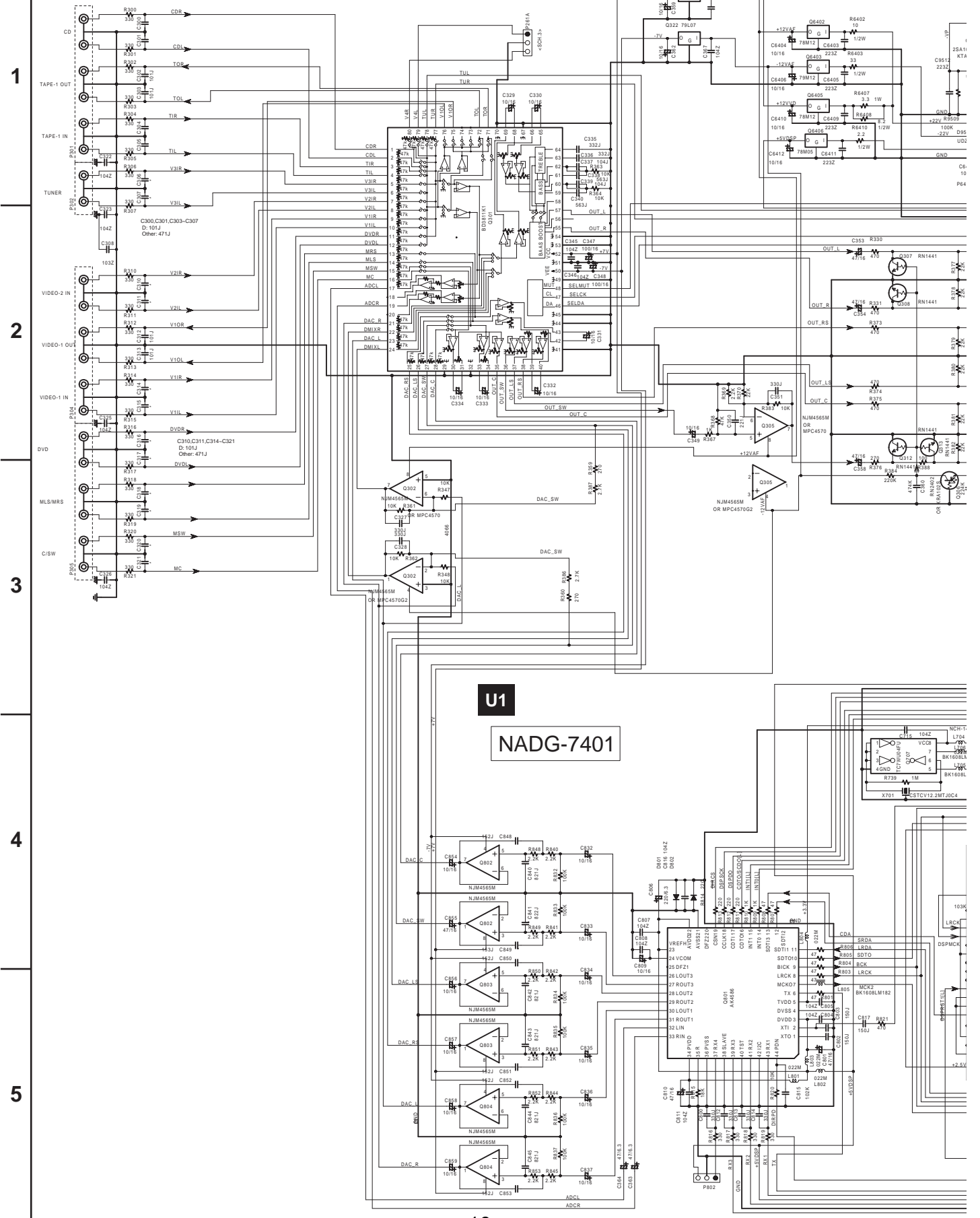

SCHEMATIC DIAGRAM 2-2 -DSP SECTION-

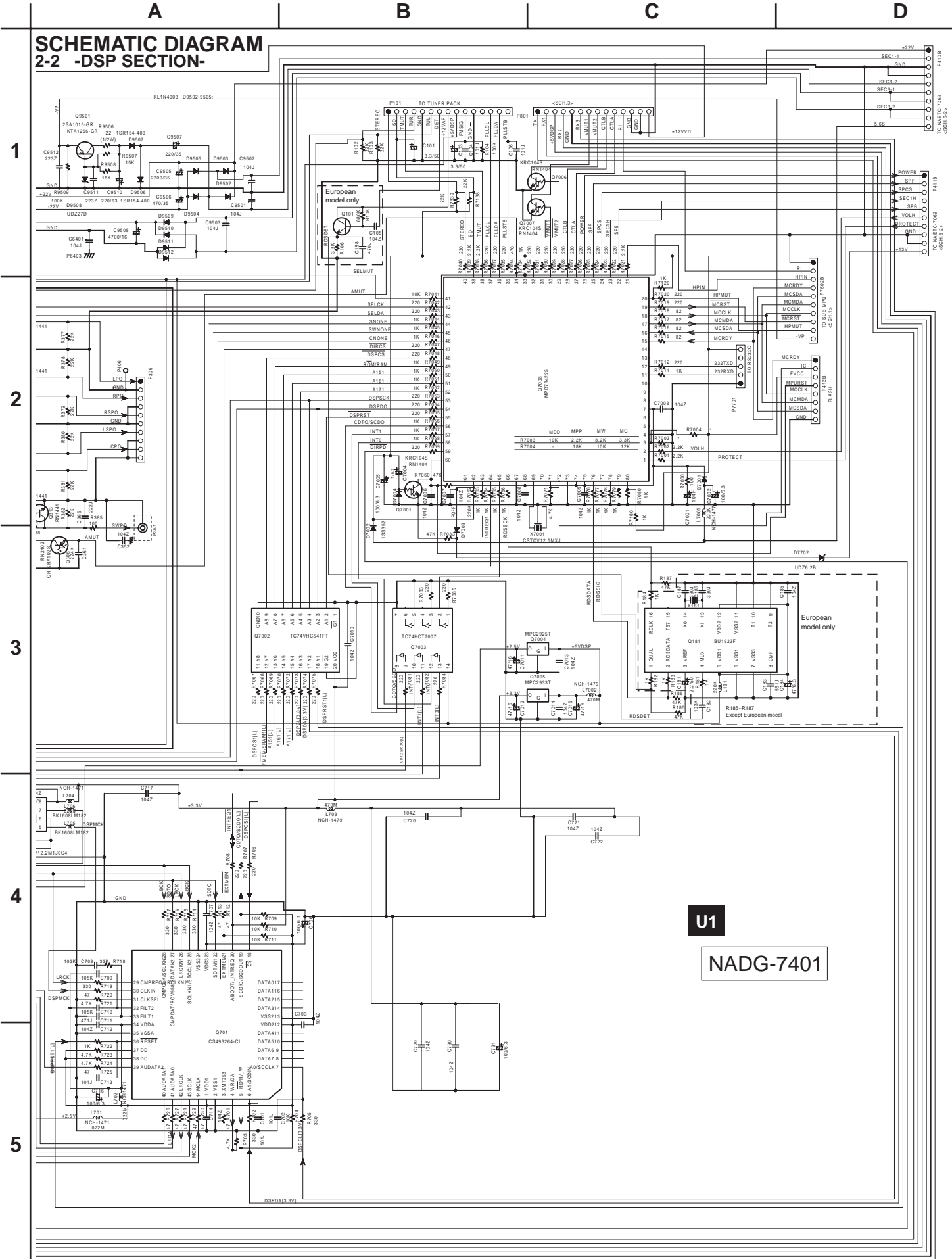

U1
NADG-7401

A B C D
SCHEMATIC DIAGRAM 3 -VIDEO SECTION-

1

2

3

4

5

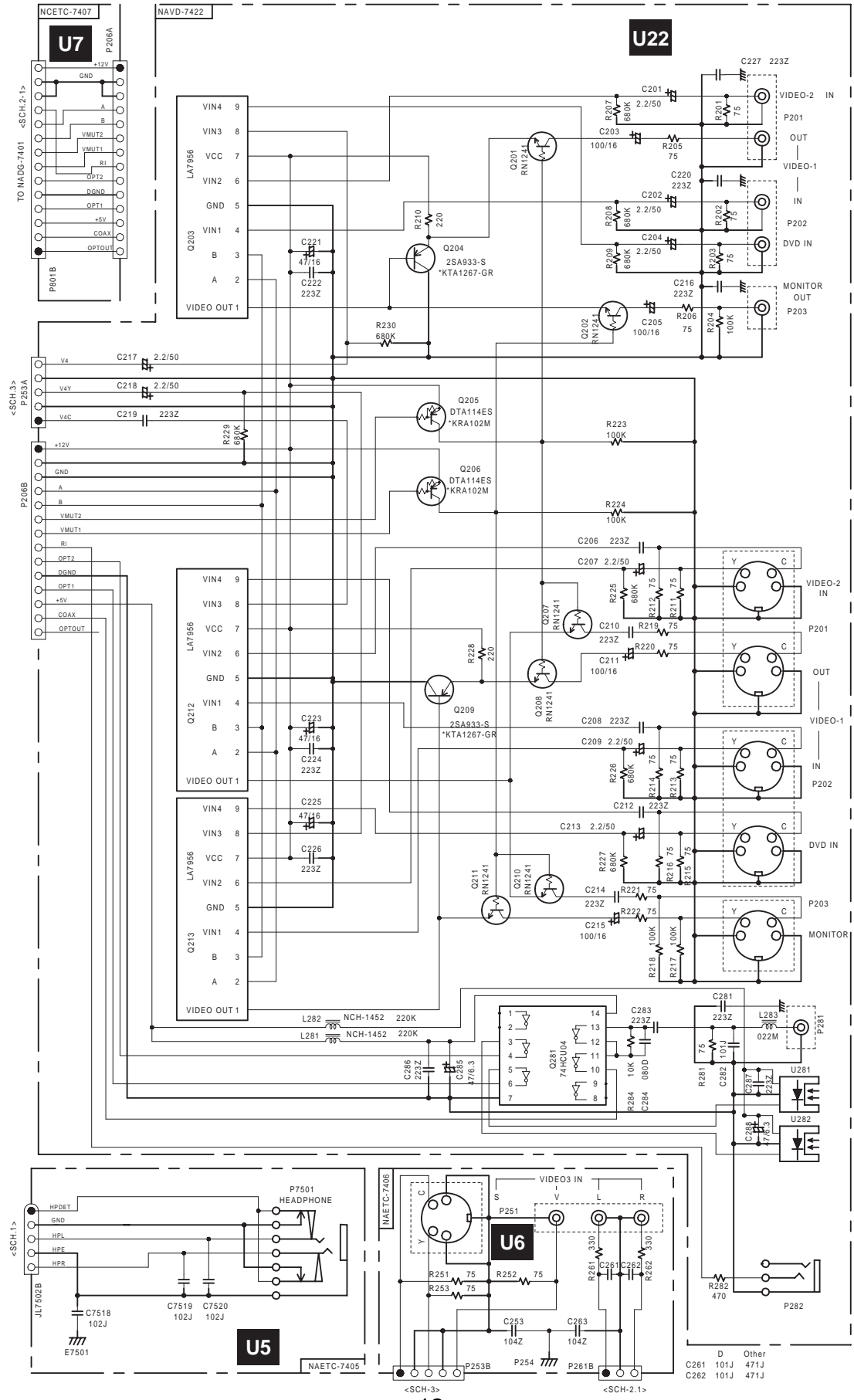

A

B

C

D

**SCHEMATIC DIAGRAM 4-1
POWER AMPLIFIER 1**

NAAF-7409

1

2

3

4

5

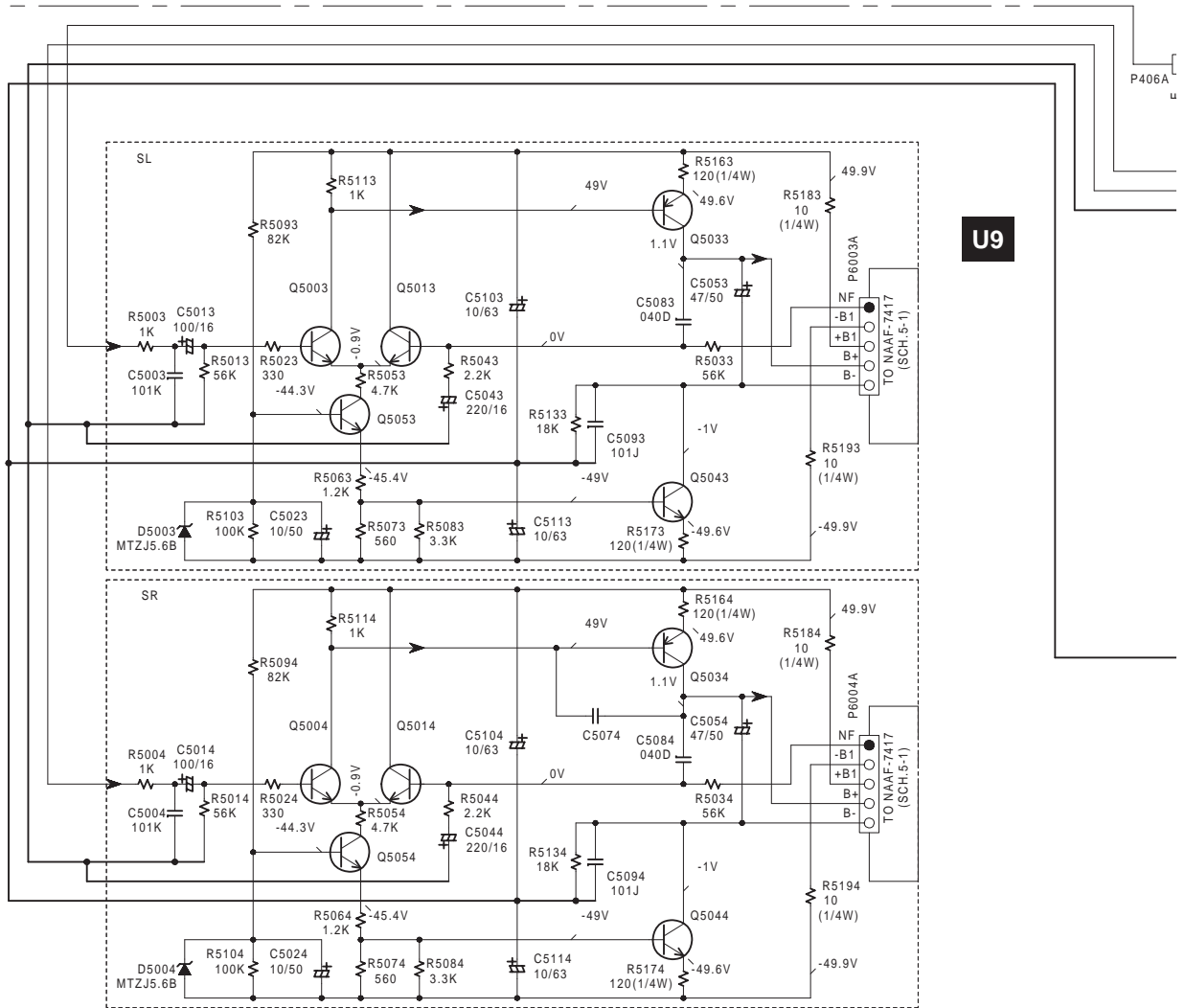

SEMICONDUCTORS

NO.	DESCRIPTION
Q5000-04,5010-14	KTC3200-BL OR 2SC1775A-E,F OR 2SC1845-E
Q5030-34	KTA1024-Y,O OR 2SA949-Y,O
Q5040-44	KTC3206-Y,O OR 2SC2229-Y,O
Q5050-54	KTC3199-GR,2SC1740S-R,S,2SC2458-GR

A **B** **C** **D**

SCHEMATIC DIAGRAM 4-2
POWER AMPLIFIER SECTION 2

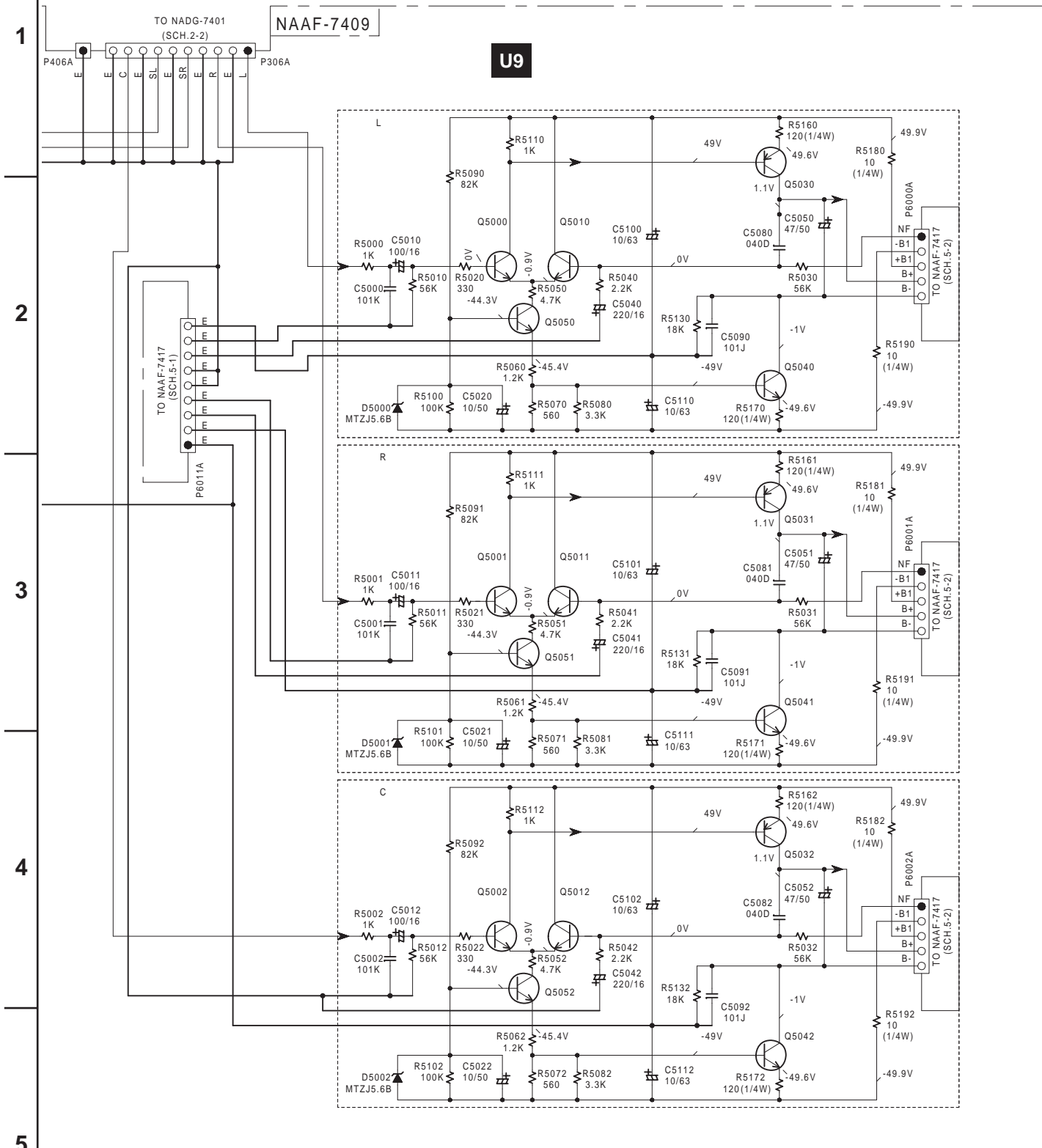

SEMICONDUCTORS

NO.	DESCRIPTION
Q5000-04,5010-14	KTC3200-BL OR 2SC1775A-E,F OR 2SC1845-E
Q5030-34	KTA1024-Y,O OR 2SA949-Y,O
Q5040-44	KTC3206-Y,O OR 2SC2229-Y,O
Q5050-54	KTC3199-GR,2SC1740S-R,S,2SC2458-GR

A B C D
SCHEMATIC DIAGRAM 5-1 POWER AMPLIFIER SECTION 3

NAAF-7417

1

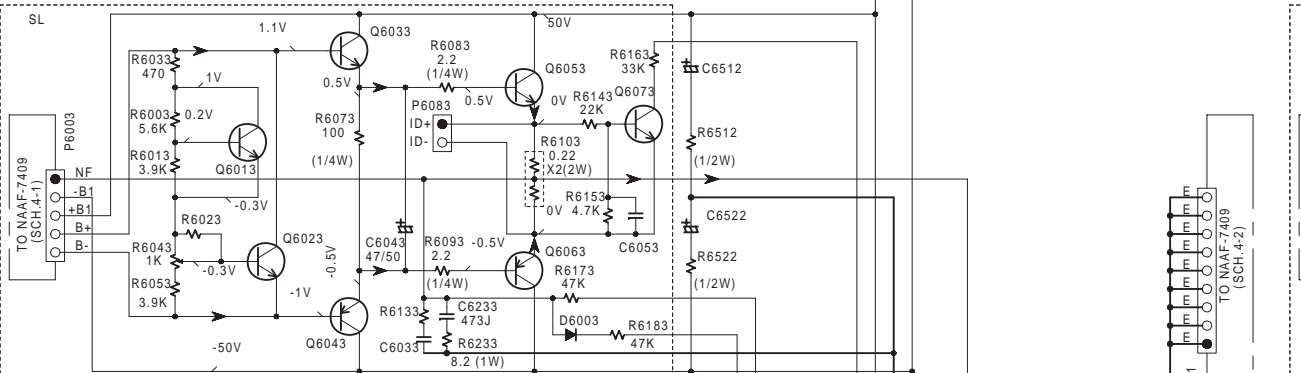

2

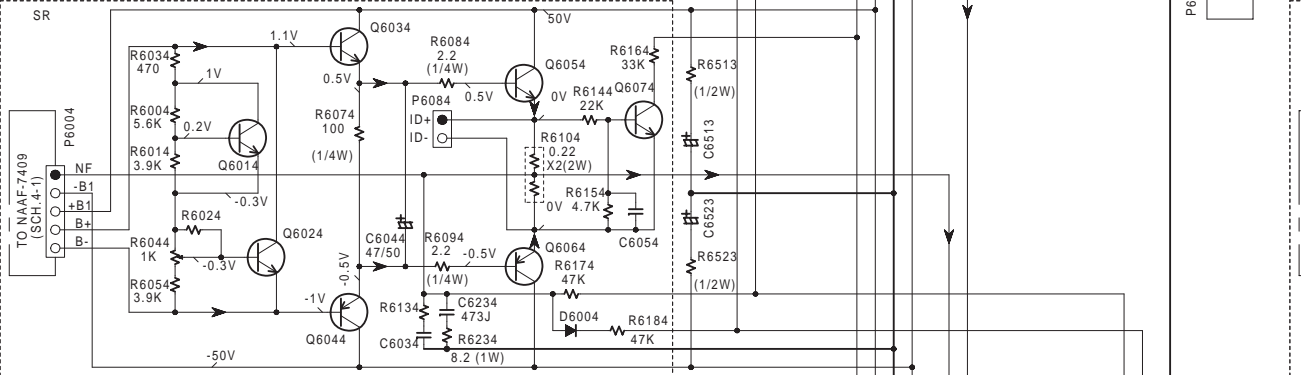

3

SEMICONDUCTORS

NO.	
Q6010-6014	2SC1740S-R,S
Q6020-6024	2SC1740S-R,S
Q6030-6034	KTD2061-Y OR 2SC5171
Q6040-6044	KTB1369-Y OR 2SA1930
Q6050-6054	MN100S-Y,P,O OR KTD1047-Y,O
Q6060-6064	MP100P-Y,P,O OR KTB817-Y,O
Q6070-6074	KTC3200-BL,GR OR 2SC1775A-E,F OR 2SC1845-E,F
Q6601-6603,Q6901	KTC3199-GR,2SC1740S-R,S,2SC2458-GR
Q6701,6702	KTC3200-BL,GR OR 2SC1775A-E,F OR 2SC1845-E,F
Q6703	KTA1268-GR,BL OR 2SA992-E,F
Q6303	KTA1267-GR OR 2SA933S-R,S

4

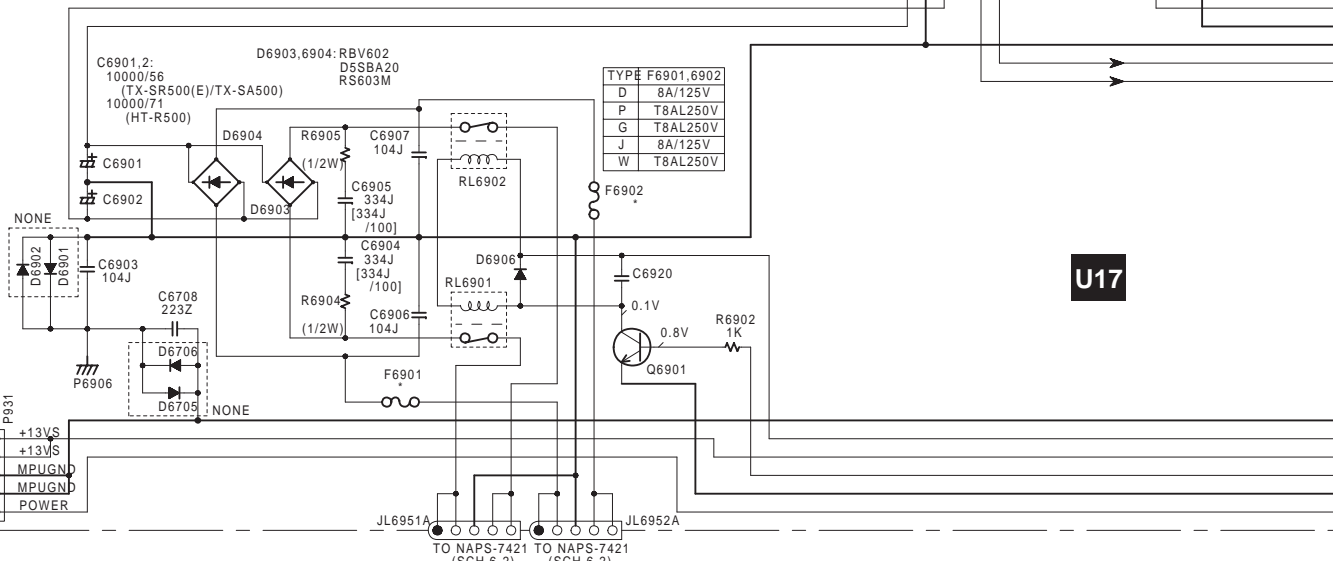

5

TO NAPS-7420 (SCH.6-1)

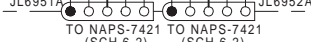
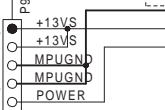

A B C D
SCHEMATIC DIAGRAM 6-1 PRIMARY AND SP TERMINAL SECTIONS

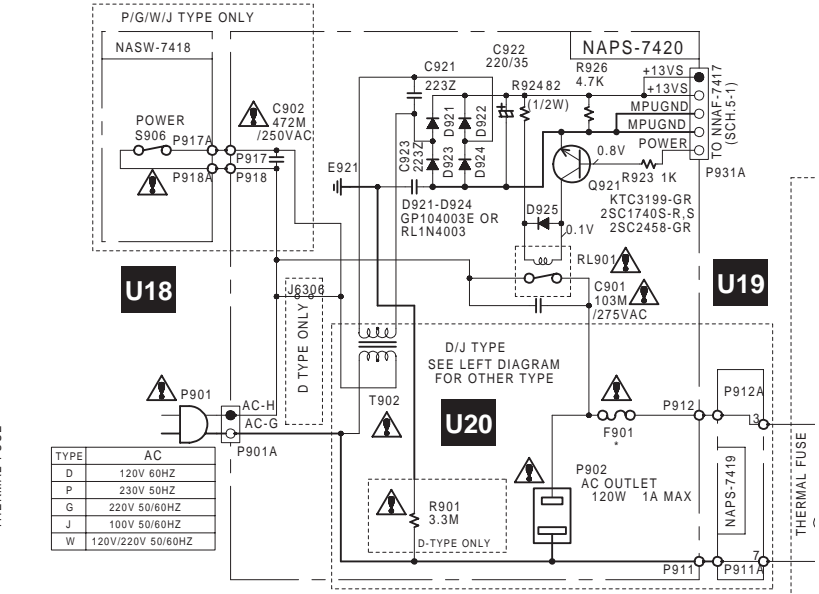
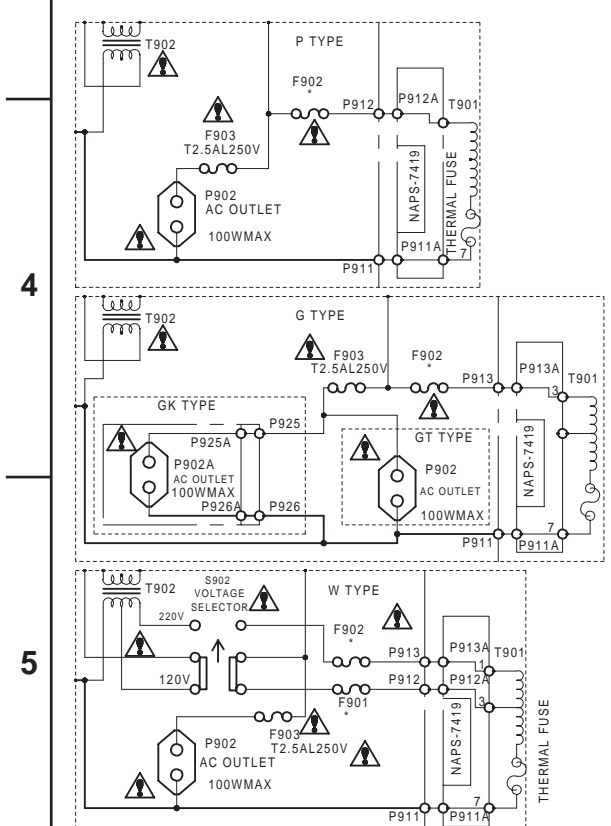
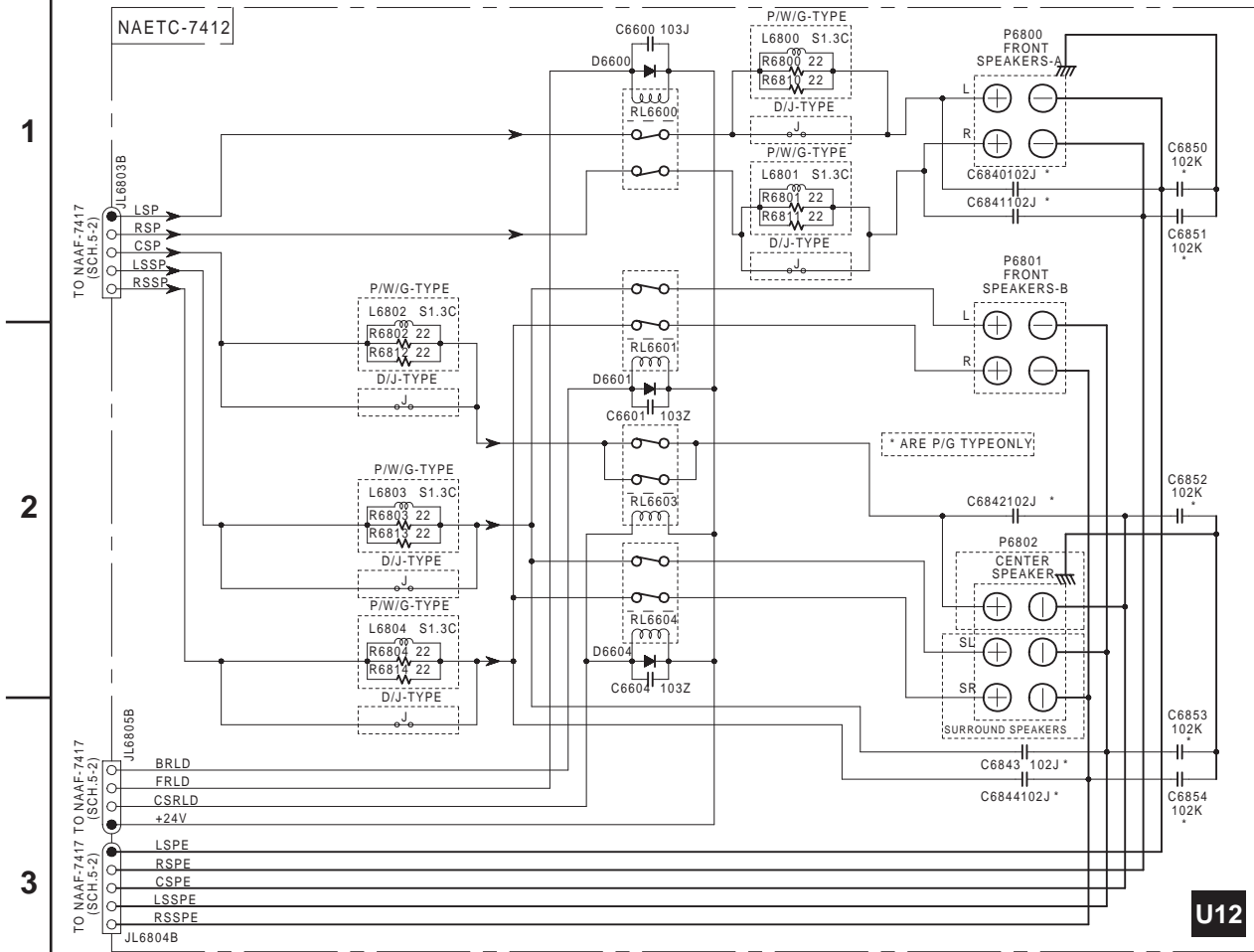

NOTE

- THE COMPONENTS IDENTIFIED BY MARK ARE CRITICAL FOR SAFETY. REPLACE ONLY WITH PART NUMBER SPECIFIED.
- VOLTAGE (MEASURED WITH VOLTMETER) IS DC VOLTAGE. (NO INPUT SIGNAL)
- ELECTROLYTIC CAPACITORS () ARE IN uF/WV.
- ALL CAPACITORS ARE IN pF/50V UNLESS OTHERWISE NOTED.
- EX) 030-3pF 330-33pF 331-330pF 333-0.03uF
- ALL RESISTORS ARE IN OHMS 1/4WATTS UNLESS OTHERWISE NOTED.
- THE THICK LINES ON PC BOARD ARE THE PRINTING SIDE OF THE PARTS.
- EX) PRINTING SIDE
- CIRCUIT IS SUBJECT TO CHANGE FOR IMPROVEMENT.
- / IS DC VOLTAGE, AT NO INPUT SIGNAL.

TYPE	F901	F902
D	6.3A/125V	NO
P	NO	T3.15AL250V
G	NO	T3.15AL250V
J	8A/125V	NO
W	6.3A/125V	T3.15AL250V



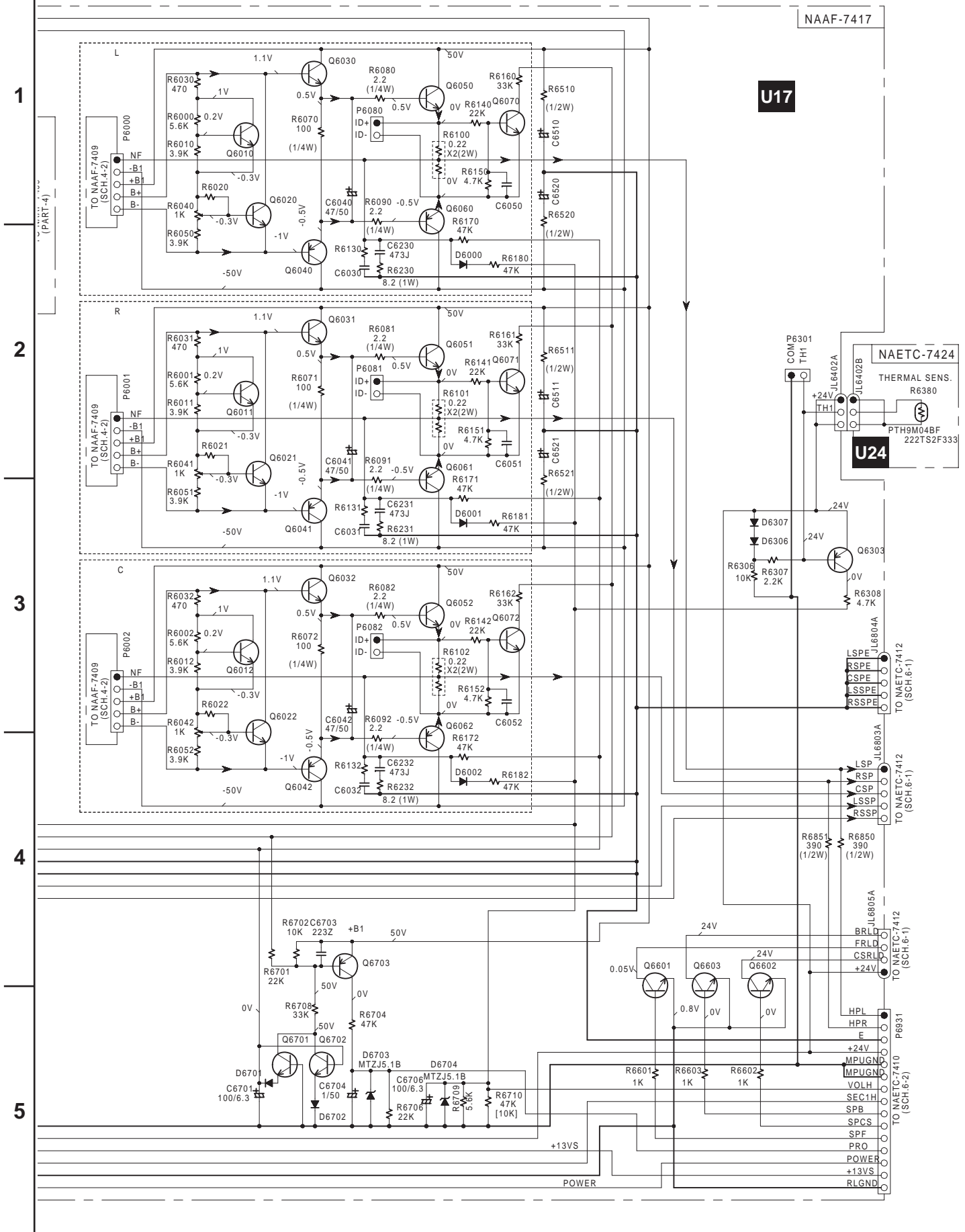

TYPE	T902
D	NPT-1358D
P	NPT-1358P
G	NPT-1358DG
J	NPT-1358J
W	NPT-1358DG

A B C D
SCHEMATIC DIAGRAM 5-2 POWER AMPLIFIER 4



A B C D
SCHEMATIC DIAGRAM 6-2 SECONDARY CIRCUIT PC BOARD

NOTE

- THE COMPONENTS IDENTIFIED BY MARK  ARE CRITICAL FOR SAFETY. REPLACE ONLY WITH PART NUMBER SPECIFIED.
- VOLTAGE (MEASURED WITH VOLTMETER)  IS DC VOLTAGE, (NO INPUT SIGNAL).
- ELECTROLYTIC CAPACITORS () ARE IN $\mu\text{F/WV}$.
- ALL CAPACITORS ARE IN $\text{pF}/50\text{V}$ UNLESS OTHERWISE NOTED.
 EX) 030-33pF 330-33pF 331-330pF 333-0.033 μF
- ALL RESISTORS ARE IN OHMS 1/4 WATTS UNLESS OTHERWISE NOTED.
- THE THICK LINES ON PC BOARD ARE THE PRINTING SIDE OF THE PARTS.
 EX)  PRINTING SIDE
- CIRCUIT IS SUBJECT TO CHANGE FOR IMPROVEMENT.
-  IS DC VOLTAGE, AT NO INPUT SIGNAL.



THIS SYMBOL LOCATED NEAR THE FUSE INDICATES THAT THE FUSE USED IS SLOW OPERATING TYPE FOR CONTINUED PROTECTION AGAINST FIRE HAZARD. REPLACE WITH SAME TYPE FUSE. FOR FUSE RATING REFER TO THE MARKING ADJACENT TO THE SYMBOL.



CE SYMBOLE INDIQUE QUE LE FUSIBLE UTILISÉ EST LENT. POUR UNE PROTECTION PERMANENTE, N'UTILISER QUE DES FUSIBLES DE MEME TYPE. CE DERNIER EST INDIQUE LA QU LE PRESENT SYMBOLE EST APPOSÉ.

CAUTION

FOR CONTINUED PROTECTION AGAINST FIRE HAZARD, REPLACE ONLY WITH FUSE OF SAME TYPE AND RATING INDICATED.



ATTENTION

AFIN D'ASSURER UNE PROTECTION PERMANENTE CONTRE LES RISQUES D'INCENDIE, REMPLACER UNIQUEMENT PAR UN FUSIBLE DE MEME TYPE ET CALIBRATION COMME INDIQUE.



TYPE	T901
D	NPT-1436D
P	NPT-1436P
G	NPT-1436DG
J	NPT-1436J
W	NPT-1436DG

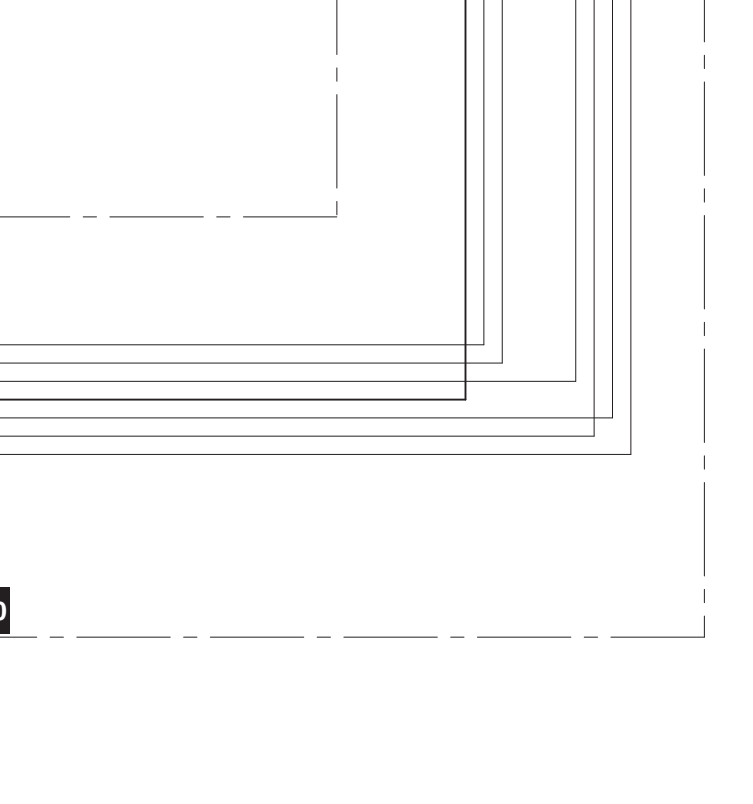
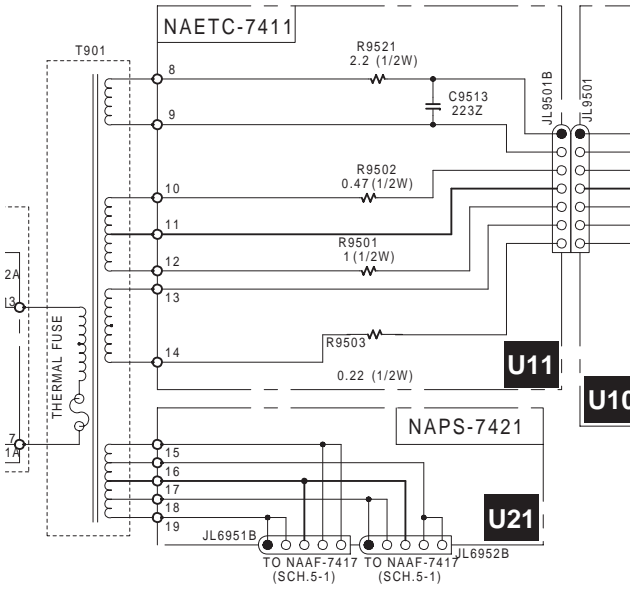
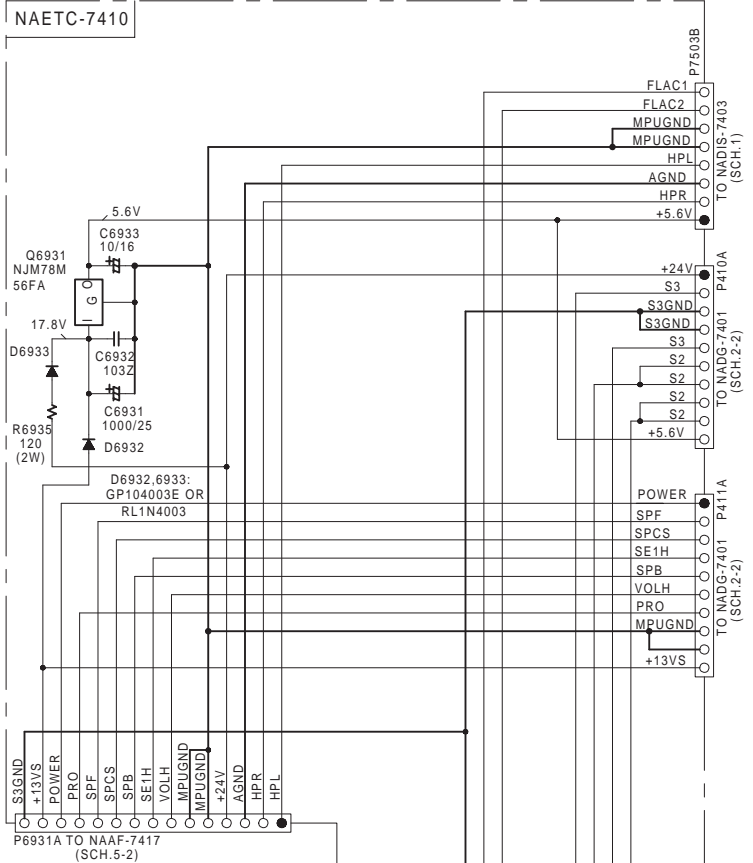

1

2

3

4

5

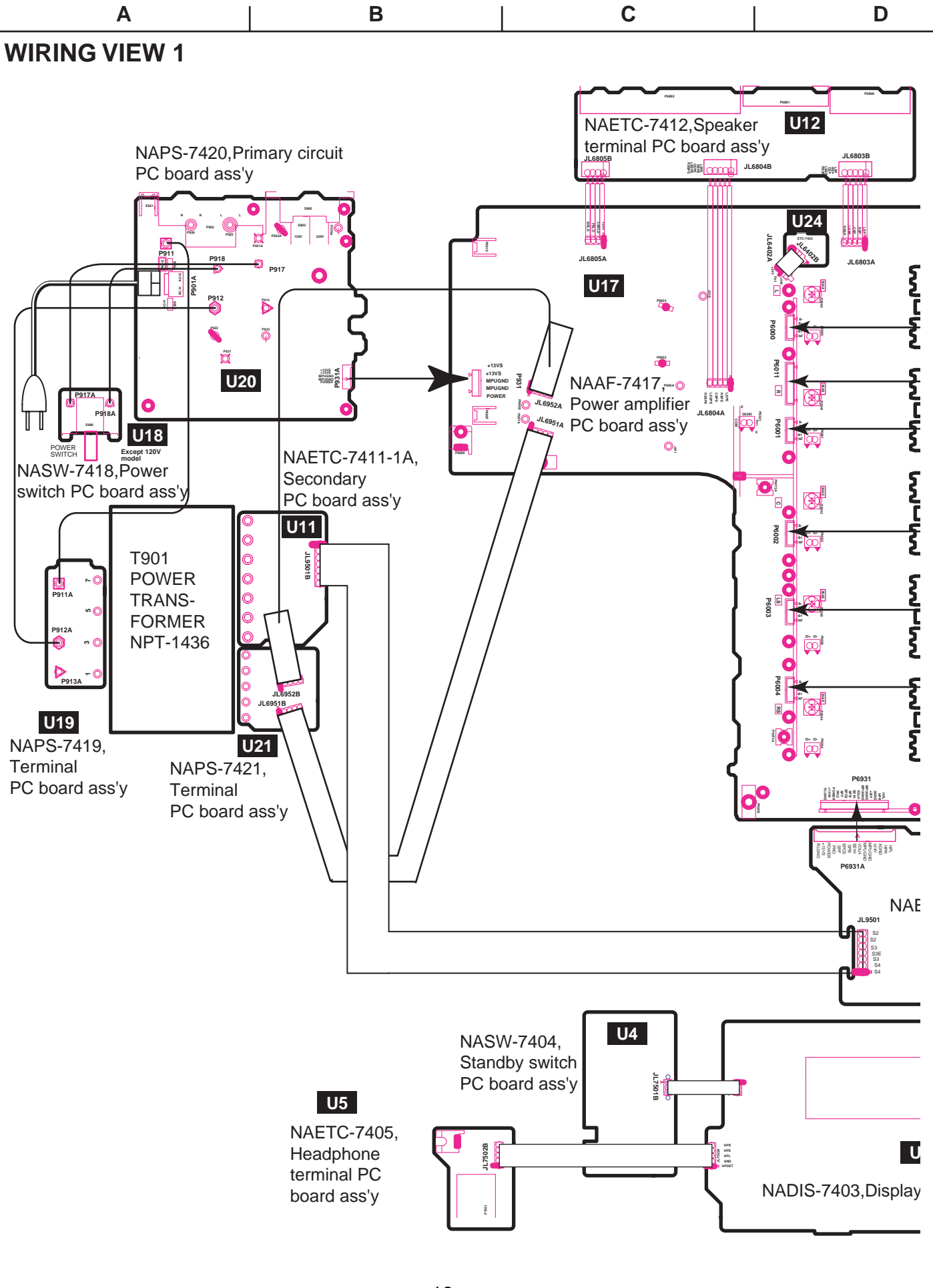

A B C D

WIRING VIEW 2

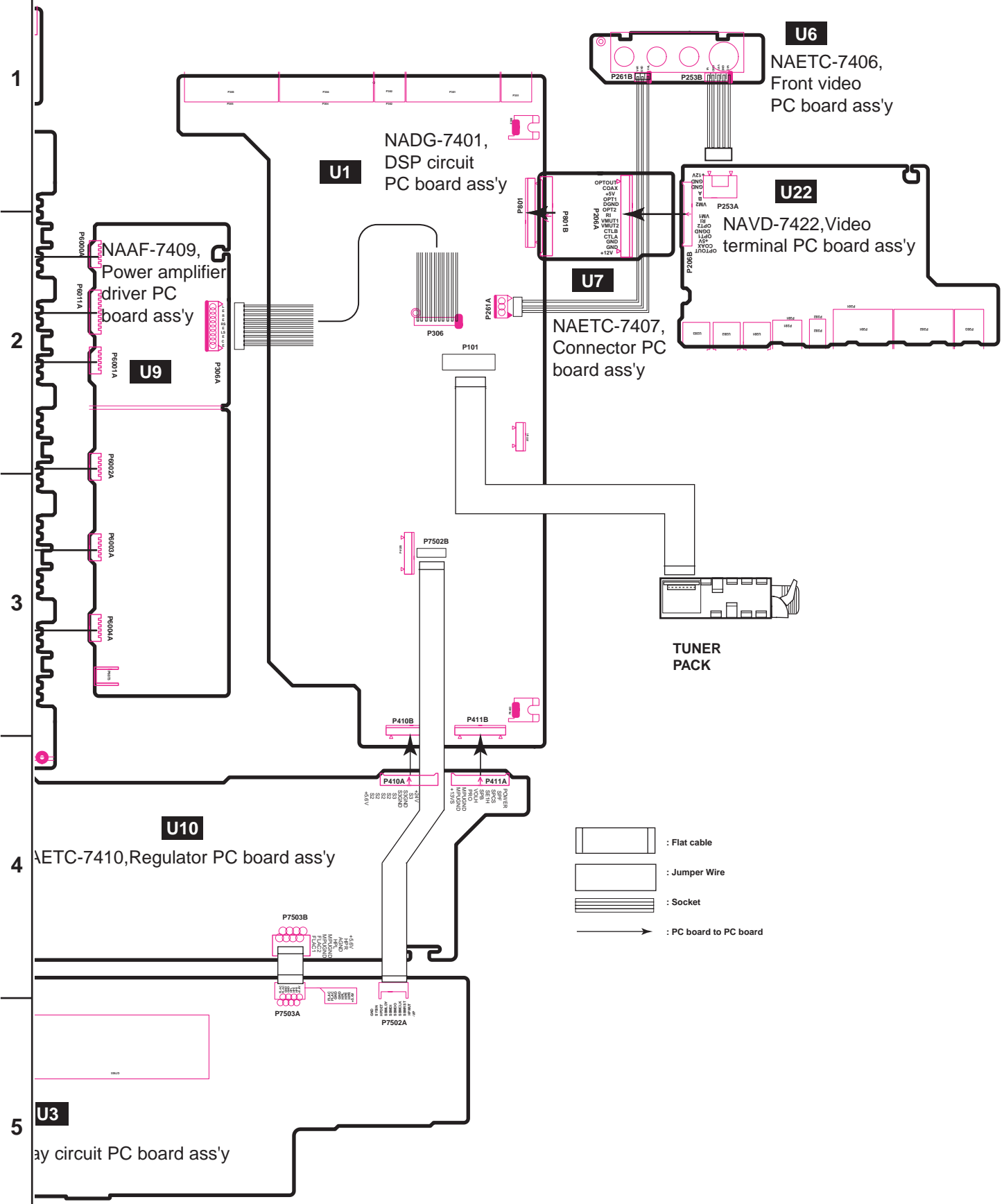

A

B

C

D

PRINTED CIRCUIT BOARD 2-2

1

U1

NADG-7401,DSP circuit PC board

Pink:Parts and Copper foil side
Black:Copper foil side

2

3

4

5

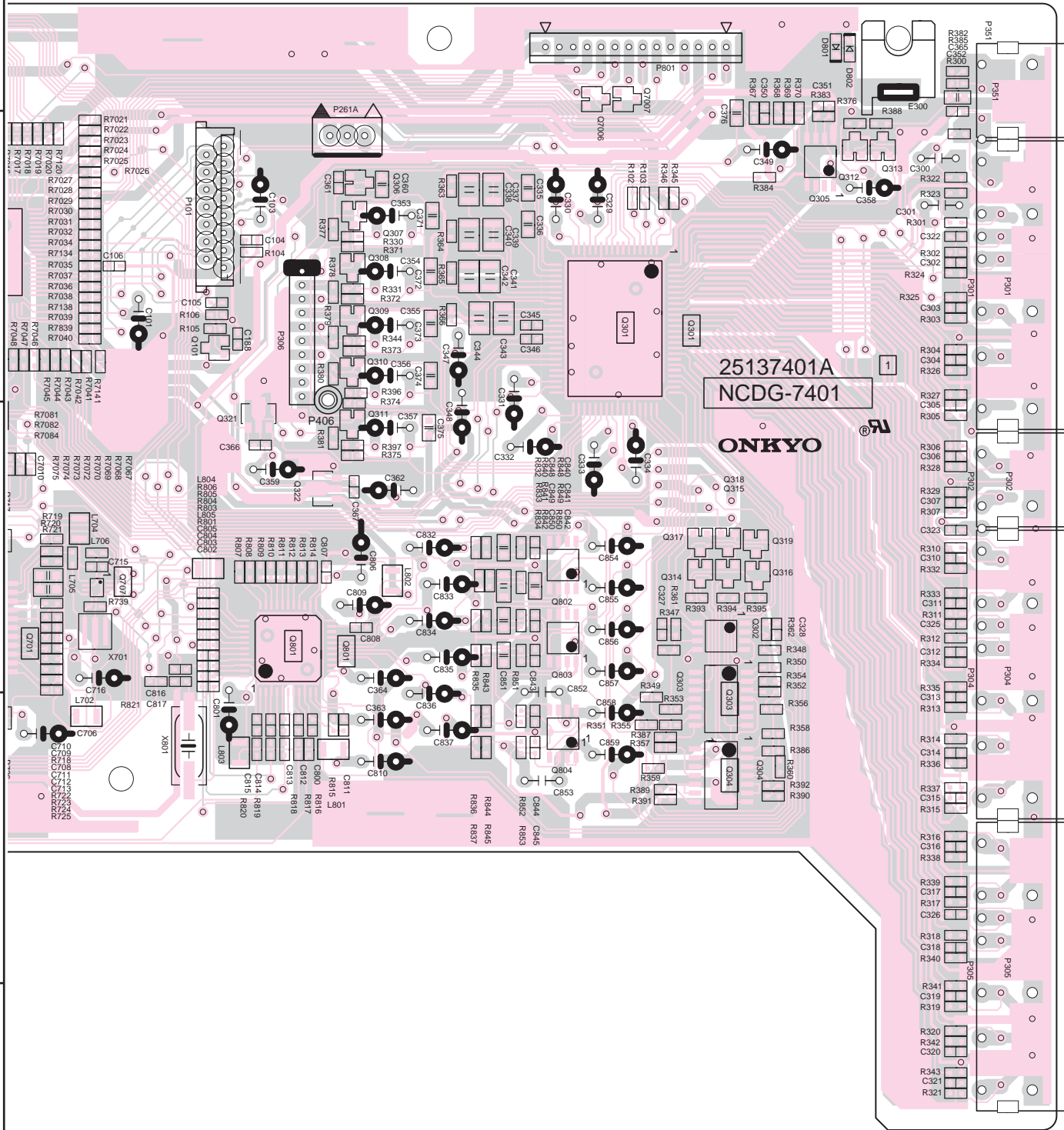

A

B

C

D

PRINTED CIRCUIT BOARD VIEW 6 FROM SOLDERING SIDE

U4 NASW-7404, Standby switch PC board

1

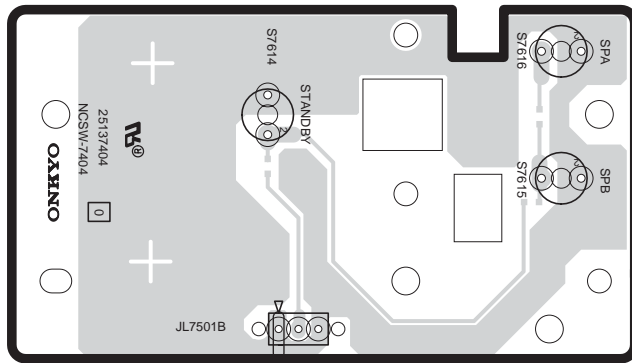

Component side

2

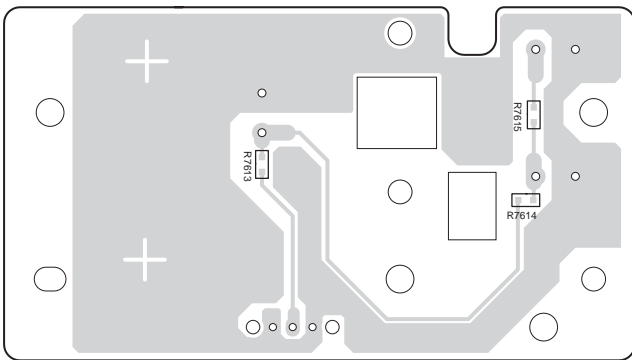

Soldering side

3

U6 NAETC-7406, Front video PC board

4

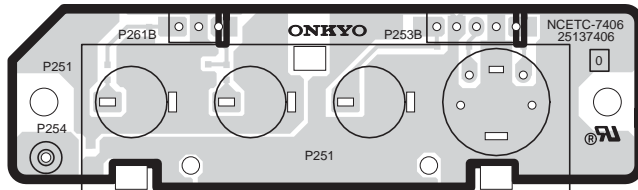

Component side

5

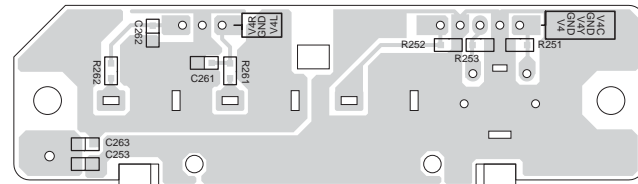

Soldering side

5

A B C D
PRINTED CIRCUIT BOARD VIEW 4-1 FROM SOLDERING SIDE

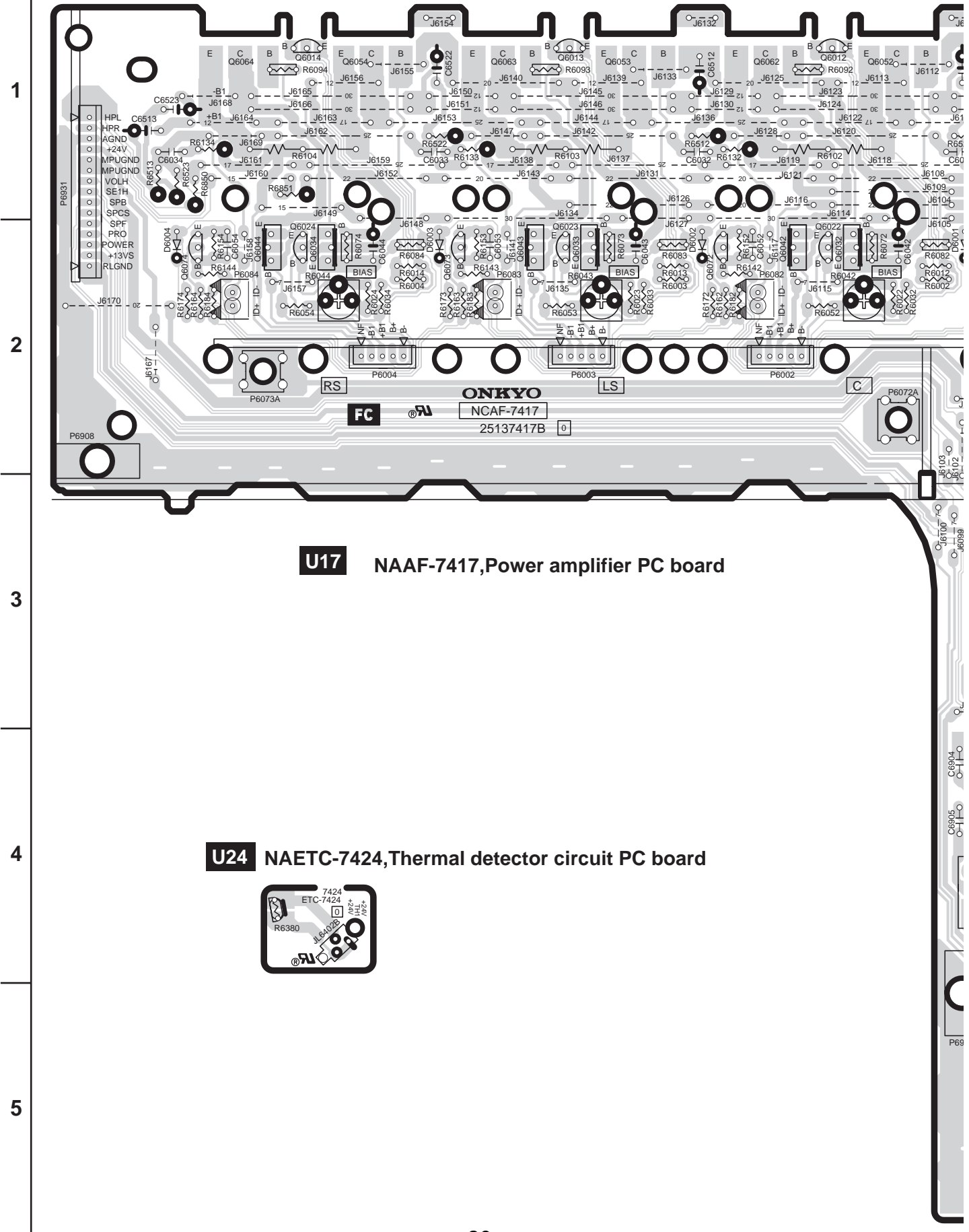

U17 NAAF-7417, Power amplifier PC board

U24 NAETC-7424, Thermal detector circuit PC board

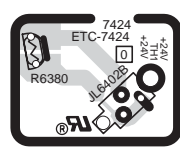

PRINTED CIRCUIT BOARD VIEW 4-1 FROM SOLDERING SIDE

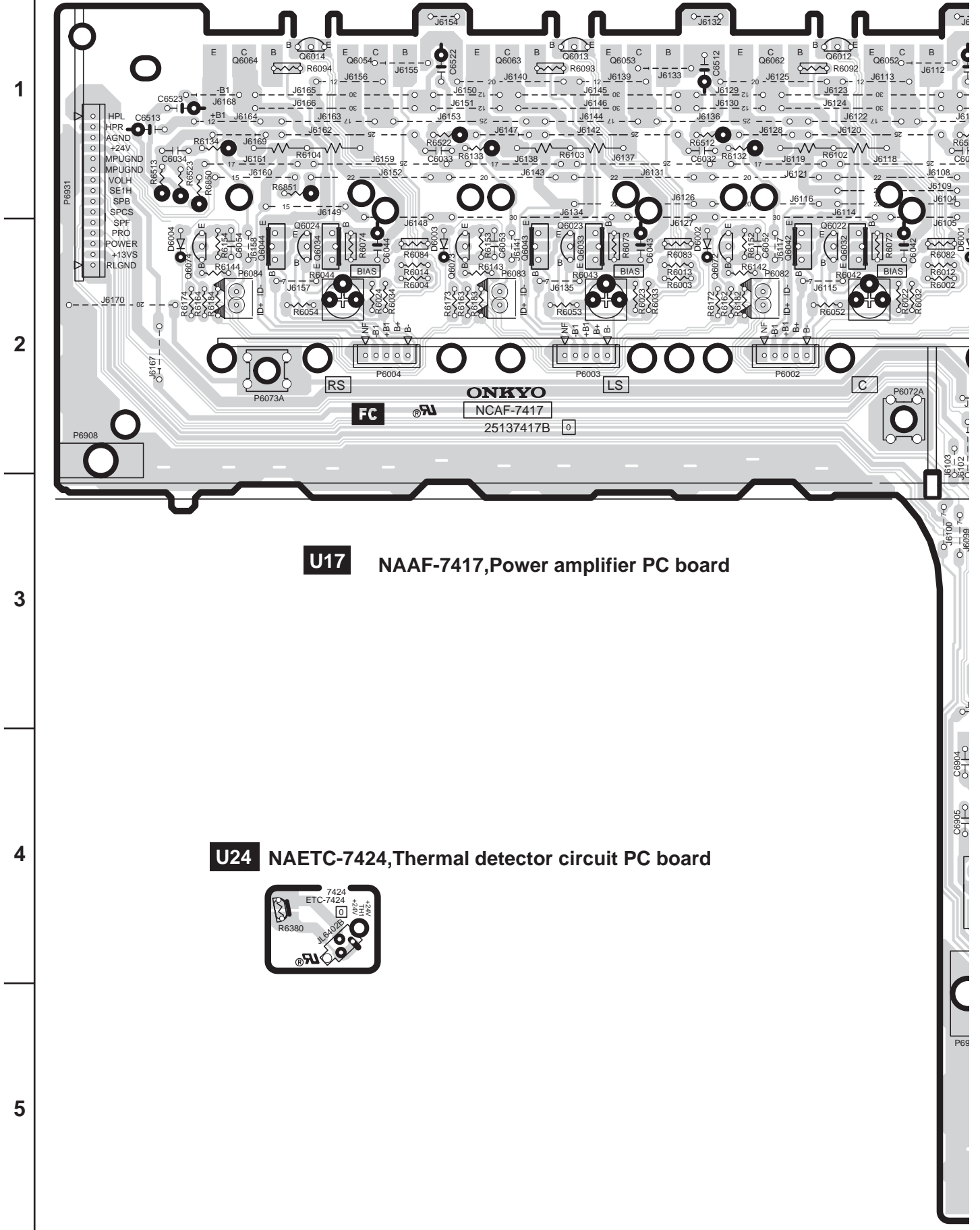

U17 NAAF-7417, Power amplifier PC board

U24 NAETC-7424, Thermal detector circuit PC board

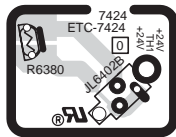

A

B

C

D

PRINTED CIRCUITBOARD VIEW 4-2 FROM SOLDERING SIDE

1

2

3

4

5

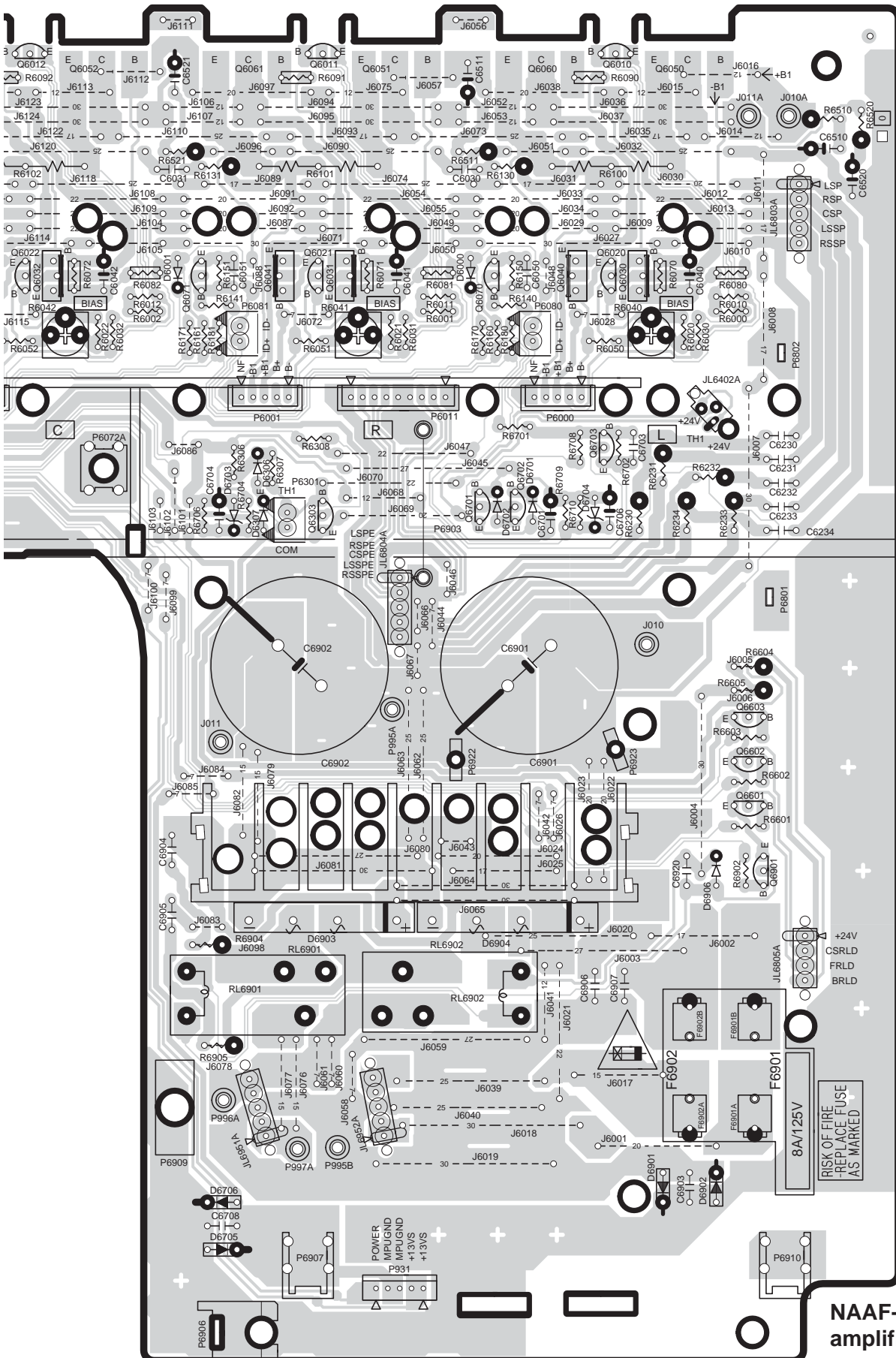

U17

NAAF-7417, Power amplifier PC board

PRINTED CIRCUIT BOARD VIEW 5-1 FROM SOLDERING SIDE

1
2
3
4
5

A

B

C

D

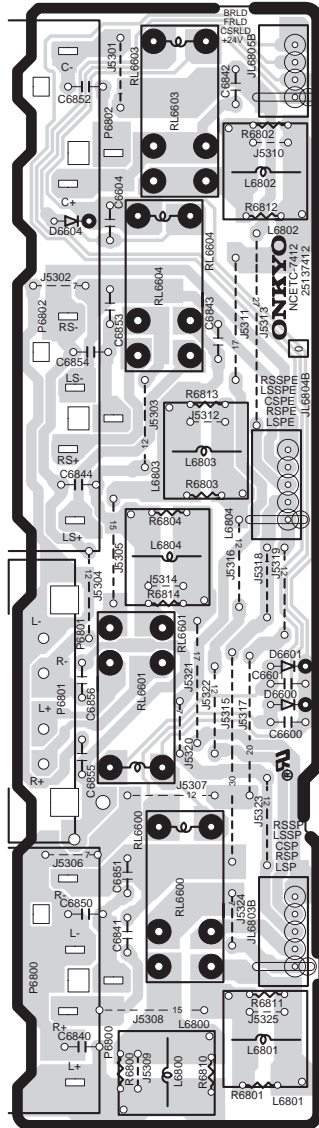

U12

NAETC-7412, Speaker terminal PC board

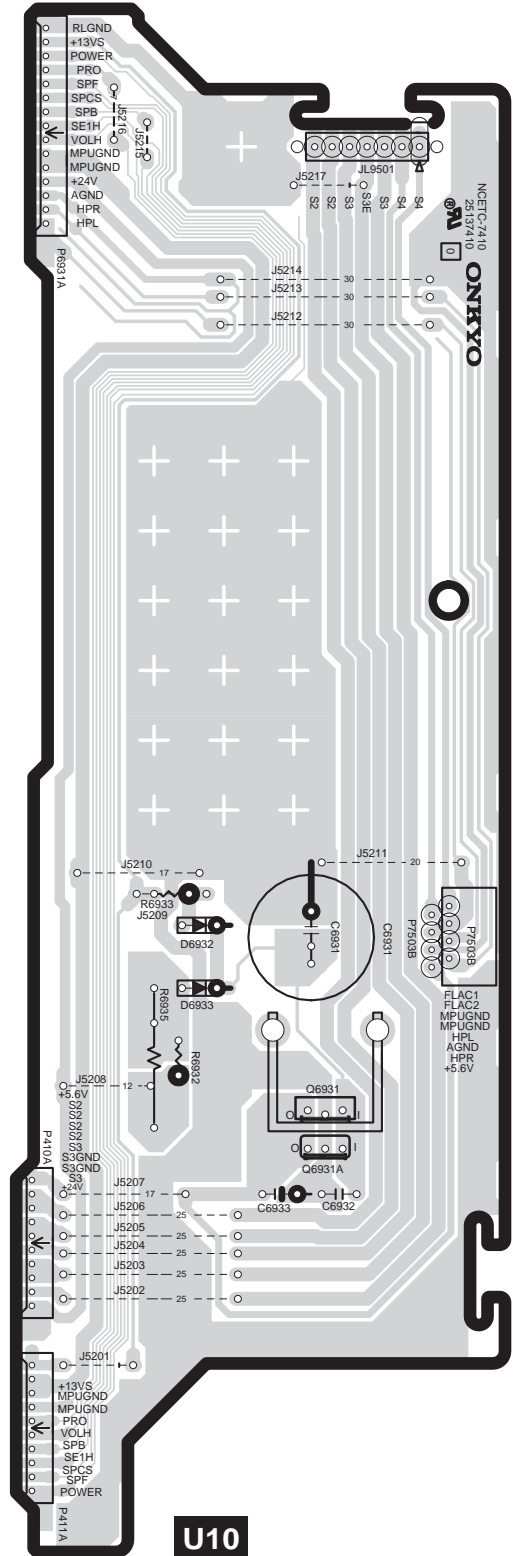

U10

NAETC-7410, Regulator PC board

A

B

C

D

PRINTED CIRCUIT BOARD VIEW 5-2 FROM SOLDERING SIDE

1

2

3

4

5

U20

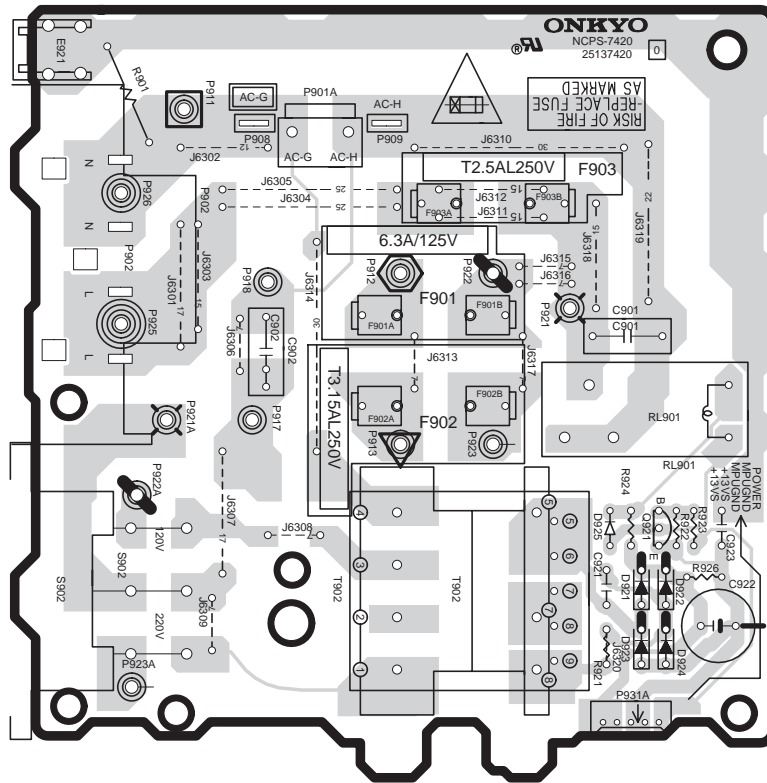

NAPS-7420, Primary circuit PC board

U11

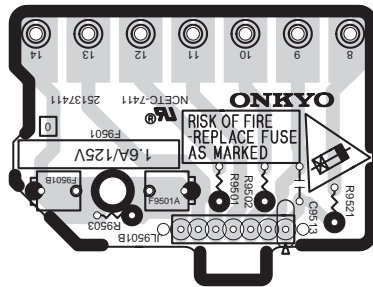

NAETC-7411, Secondary PC board

U21

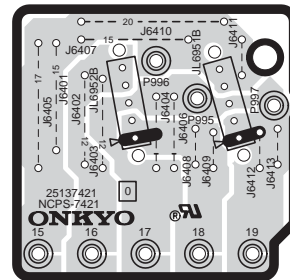

NAPS-7421, Terminal PC board

U19

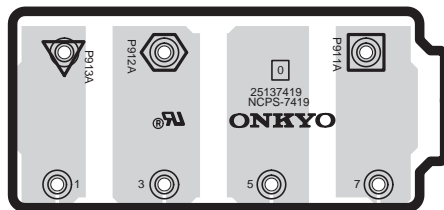

NAPS-7419, Terminal PC board

U18

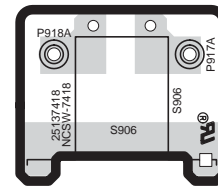

NASW-7418, Power switch PC board (Except 120V model)

PRINTED CIRCUIT BOARD VIEW 3 FROM SOLDERING SIDE

1
2
3
4
5

U22

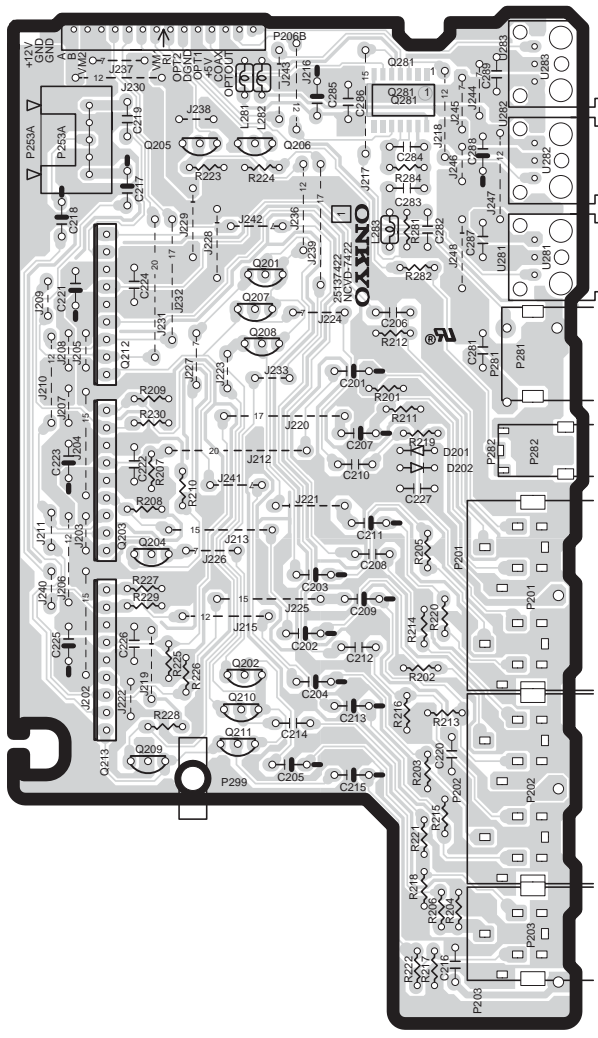

NAVD-7422, Video terminal PC board

U9

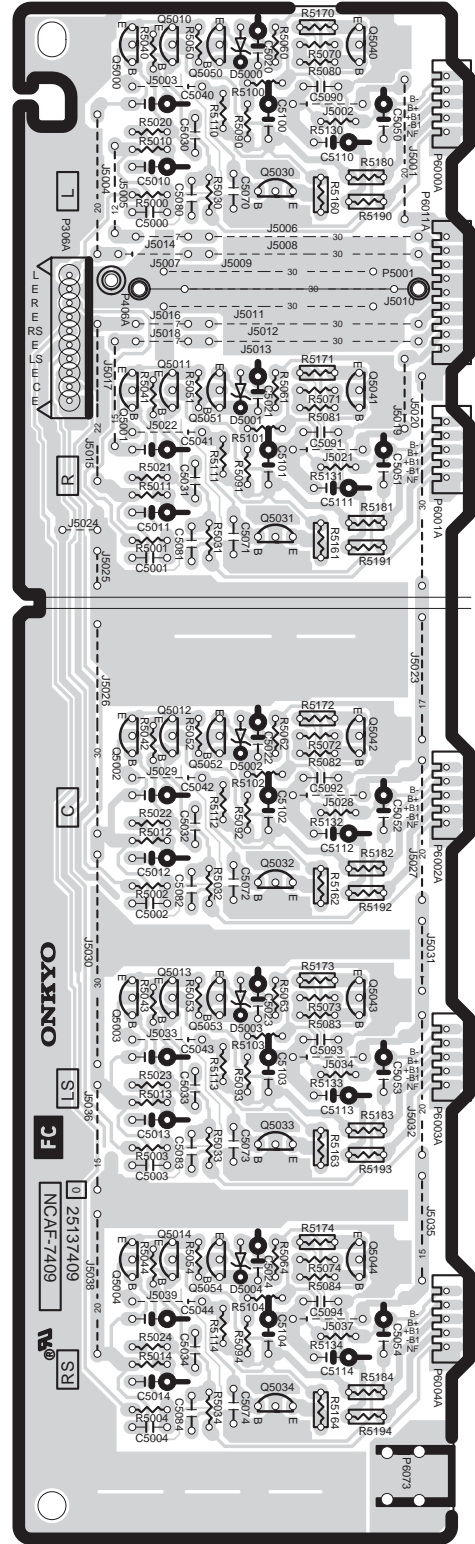

NAAF-7409, Power amplifier driver PC board

PRINTED CIRCUIT BOARD-PARTS LIST 1

NOTE: <D>:120V model only
<P>: European model only
<O>: Except 120V model

DSP CIRCUIT PC BOARD <NADG-7401-1A/1B/1C/1D>			CIRCUIT NO.	PART NO.	DESCRIPTION
CIRCUIT NO.	PART NO.	DESCRIPTION		Capacitors	
			C101,C103	394680337	3.3uF,50V,Elect.
Q181	22241297R2	BU1923F <P>	C181	394680227	2.2uF,50V,Elect. <P>
Q301	22241761R3	BD3811K1	C184	354744709	47uF,16V,Elect. <P>
Q302,Q305	22241383R2,	NJM4565M-D,	C300,C301	374721015	100pF+/-10%,50V,Plastic <D>
Q802-Q804	22240489R1NE or 22240581R2	MPC4570G2-T1(MST) or NJM4565M		374724714	470pF+/-5%,50V,Plastic <O>
Q321	222780073R2	78L07(SMT)	C329-C334	393341007	10uF,16V,Elect.
Q322	222790073R2	79L07(SMT)	C335,C336	373043324R2	3300pF+/-5%,16V,Plastic
Q6402,Q6405	222780125	78M12HF	C338,C340	373045634R2	0.056uF+/-5%,16V,Plastic
Q6403	222790125	79M12HF	C347,C348	394641017	100uF,16V,Elect.
Q6406	222780055	78M05HF	C349	393341007	10uF,16V,Elect.
Q7002	22274541ER2TO or 22274541IR2TI	TC74VHC541FT or SN74AHC541PWR	C353,C354	393344707	47uF,16V,Elect.
Q7003	222740077R2TO	TC74HCT7007AF	C358	393344707	47uF,16V,Elect.
Q7004	22278025DR2NE or 22278025DR2JR	MPC2925T or NJM2391DL1-25	C359,C362	394641007	10uF,16V,Elect.
Q7005	22278033DR2NE or 22278033DR2JR	MPC2933T or NJM2391DL1-33	C363,C364	393341007	10uF,16V,Elect.
Q7008	22241881R3 or 22241766R3	MPD784225GC-183-8BT or MPD78F4225(No spare part)	C6401	374721044	0.1uF+/-5%,50V,Plastic
Q701	22241762R2	CS493264	C6404,C6406	394641007	10uF,16V,Elect.
Q707	22240935R2	TC7WU04FU	C6410,C6412	394641007	10uF,16V,Elect.
Q801	22241620R3	AK4586	C7001	3000078,	DX-5R5L104,
				3000120 or 3000121	FMC0H104Z or SCDA5R5104A,Super
Q101	2216175R2 or 2213145R2	KTC3875-GR or 2SC2712-GR <P>	C7002,C7005	394621017	100uF,6.3V,Elect.
Q306	2214530R2 or 2216220R2	RN2402 or KRA102S	C7004	394680107	1uF,50V,Elect.
Q307,Q308	2215410R2	RN1441	C7011,C7012	394644707	47uF,16V,Elect.
Q312,Q313	2215410R2	RN1441	C7015	394644707	47uF,16V,Elect.
Q7001	2214490R2 or	RN1404 or	C706,C716	394621017	100uF,6.3V,Elect.
Q7006,Q7007	2216210R2	KRC104S	C731	394621017	100uF,6.3V,Elect.
Q9501	2211455	2SA1015-GR	C801,C810	394644707	47uF,16V,Elect.
			C806	394622217	220uF,6.3V,Elect.
D7001-D7004	223234R2 or	1SS352 or	C809	394641007	10uF,16V,Elect.
D801,D802	223269R2	1SS355	C832-C837	393341007	10uF,16V,Elect.
D7702	224660624R2, 224490620R2 or 224550620R2	HZU6.2B, UDZ6.2B or UDZS6.2B	C841	373048224R2	8200pF+/-5%,16V,Plastic
D9502-D9507	22380260,	RL1N4003,	C849	373041534R2	0.015uF+/-5%,16V,Plastic
D9509-D9512	22380032 or 22380035	1SR139-100 or GP104003E	C852,C853	374721524	1500pF+/-5%,50V,Plastic
D9508	224662704R2, 224492700R2 or 224552700R2	HZU27B, UDZ27B or UDZS27B	C854	393341007	10uF,16V,Elect.
			C855	393344707	47uF,16V,Elect.
			C856-C859	393341007	10uF,16V,Elect.
			C9501-C9503	374721044	0.1uF+/-5%,50V,Plastic
			C9505	394662227	2200uF,35V,Elect.
			C9506	394664717	470uF,35V,Elect.
			C9507	394662217	220uF,35V,Elect.
			C9508	394644727	4700uF,16V,Elect.
			C9510	394672217	220uF,63V,Elect.
					Resistors
			R6402	442521004	10ohm+/-5%,1/2W,Metal oxide
			R6403	442523304	33ohm+/-5%,1/2W,Metal oxide
			R6410	453530224	2.2ohm+/-5%,1/2W,Metal
			R6407	452630334	3.3ohm+/-5%,1W,Metal
			R9506	443522204	22ohm+/-5%,1/2W,Metal oxide
					Terminals
X181	3010203 or 3010345	AF6146CG or HQS-3H2-04332-20,Crystal <P>	P301,P304	25045571 or 25045300	NPJ-6PDRW386 or NPJ-6PDBL159
X7001	3010361R2	CSTCE12M5G52-R0,Ceramic		25045572 or 25045649	NPJ-6PDBRW387 or NPJ-6PDBRW453
X701	3010324R2	CSTCV12.2MTJ0C4,Ceramic		25045567	NPJ-1PDBL382
					Sockets
L181	231237K220R2	NCH-1477 <P>	P101	25052211 or 25052024	NSCT-15P2108 or NSCT-15P1811
L7001,L7002	231237K470R2	NCH-1479		2009990717UL	NSAS-20P1004
L701,L702	231237M022R2	NCH-1471	P305	25052576R2	NSCT-10P2473
L703	231237K470R2	NCH-1479	P351		
L704	231237M022R2	NCH-1471			
L705,L706	230958R1	BK1608LM182-T			
L805	230958R1	BK1608LM182-T			
L801-L804	231237M022R2	NCH-1471			

PRINTED CIRCUIT BOARD-PARTS LIST 2

CIRCUIT NO.	PART NO.	DESCRIPTION
	Plugs	
P261A	25055133	NPLG-3P117
P410B,P411B	25055706	NPLG-10P662
P801	25055710	NPLG-14P666
	Radiator	
Q6402B	27160500	RAD-165
	Screws	
Q6402A,Q6405A	82143010	3P+10FN(BC),Pan head
Q6406A	82143010	3P+10FN(BC),Pan head

DISPLAY CIRCUIT PC BOARD <NADIS-7403-1A/1B>

CIRCUIT NO.	PART NO.	DESCRIPTION
	FL tube	
Q7501	212229	HNA-16MM39T
	Sensor	
U7501	241341	SPS-444-1-E1
	IC	
Q7502	22241571R3	MPD780232GC-030-8BT
	Transistors	
Q7504	2216230R2 or 2214540R2	KRA103S or RN2403
Q7506	2216190R2 or 2214470R2	KRC102S or RN1402
	Diodes	
D7501	224490820R2, 224550820R2 or 224660824R2	UDZ8.2B, UDZS8.2B or HZU8.2B
D7502	224490510R2, 224550510R2 or 224660514R2	UDZ5.1B, UDZS5.1B or HZU5.1B
D7503,D7507	223234R2 or 223269R2	1SS352 or 1SS355
D7505	225290	SEL4110R
	Oscillator	
X7501	3010242	CST5.00MGW,Ceramic
	Coils	
L7504,L7505	231237K220R2	NCH-1477
	Capacitors	
C7502	355783309	33uF,50V,Elect.
C7514	394621017	100uF,6.3V,Elect.
C7521	355722219	220uF,6.3V,Elect.
	Switches	
S7501	25065627	EC12E2425
S7611~S7613	25035699 or	NPS-111-S662 or
S7621~S7627	25035714	NPS-111-S677
S7631~S7637	25035699 or	NPS-111-S662 or
S7641~S7647	25035714	NPS-111-S677
	Sockets	
JL7501A	25051107	NSCT-3P894
JL7502A	25051109	NSCT-5P896
P7502A	25051892 or 25052477	NSCT-10P1679 or NSCT-10P2374
P7503A	25052054 or 25051852	NSCT-8P1841 or NSCT-8P1639
	Holder	
Q7501A	27190989A	(FL)

STANDBY SWITCH PC BOARD <NASW-7404-1A/1B>

CIRCUIT NO.	PART NO.	DESCRIPTION
S7614~S7616	25035699 or 25035714	NPS-111-S662 or NPS-111-S677,Switch
JL7501B	25051107	NSCT-3P894,Socket

HEADPHONE TERMINAL PC BOARD <NAETC-7405-1A/1B>

CIRCUIT NO.	PART NO.	DESCRIPTION
P7501	25045514	YKB26-5005,Headphone
JL7502B	25051109	NSCT-5P896,Socket

FRONT VIDEO PC BOARD <NAETC-7406-1A/1B>

CIRCUIT NO.	PART NO.	DESCRIPTION
P251	25045680	NPJ-7PDB477, Terminal
P253B	2009990578UL	NSAS-10P0787,Socket
P261B	2009990513UL	NSAS-6P0675,Socket

CONNECTOR PC BOARD <NAETC-7407-1A/1B>

CIRCUIT NO.	PART NO.	DESCRIPTION
P206A	25055710	NPLG-14P666,Plug
P801B	25051239	NSCT-14P1029

POWER AMPLIFIER DRIVER PC BOARD <NAAF-7409-1A/1B>

CIRCUIT NO.	PART NO.	DESCRIPTION
	Transistors	
Q5000~Q5004	2215896,	* KTC3200-BL,
Q5010~Q5014	2210755, 2210756 or 2211733	* 2SC1775A-E, * 2SC1775A-F or * 2SC1845-E
Q5030~Q5034	2215844, 2211353, 2211354 or 2215843	KTA1024-Y, 2SA949-O, 2SA949-Y or KTA1024-O
Q5040~Q5044	2215854, 2211633, 2211634 or 2215853	KTC3206-Y, 2SC2229-O, 2SC2229-Y or KTC3206-O
Q5050~Q5054	2215864, 2212115, 2213284 or 2213285	KTC3199-GR, 2SC2458-GR, 2SC1740S-R or 2SC1740S-S
	Diodes	
D5000~D5004	224470562	MTZJ5.6B
	Capacitors	
C5000~C5004	374721015	100pF+/-10%,50V,Plastic
C5010~C5014	393341017	100uF,16V,Elect.
C5020~C5024	394681007	10uF,50V,Elect.
C5040~C5044	393342217	220uF,16V,Elect.
C5050~C5054	394684707	47uF,50V,Elect.
C5100~C5104	394671007	10uF,63V,Elect.
C5110~C5114	394671007	10uF,63V,Elect.
	Resistors	
R5160~R5164	415471214	120ohm+/-5%,1/4W,NF carbon
R5170~R5174	415471214	120ohm+/-5%,1/4W,NF carbon
R5180~R5184	415471004	10ohm+/-5%,1/4W,NF carbon
R5190~R5194	415471004	10ohm+/-5%,1/4W,NF carbon
	Sockets	
P6000A~P6004A	25052288	NSCT-5P2185
P6011A	25052292	NSCT-9P2189
	Plug	
P306A	25055154	NPLG-10P138
	Bar	
P5001	27141773	BBL40

CAUTION: Replacement for transistor of mark *, if necessary must be made from the same beta group (Hfe) as the original type.

PRINTED CIRCUIT BOARD-PARTS LIST 3

REGULATOR PC BOARD (NAETC-7410-1A/1B)

CIRCUIT NO.	PART NO.	DESCRIPTION
Q6931	222780565JRC	NJM78M56FA,IC
D6932,D6933	22380260 or 22380035	RL1N4003 or GP104003E,Diode
C6931	394651027	1000uF,25V,Elect. capacitor
C6933	394641007	10uF,16V,Elect. capacitor
R6935	441721214	120ohm+/-5%,2W,Metal oxide resistor
JL9501A	25051111	NSCT-7P898,Socket
P410A,P411A	25051235	NSCT-10P1025,Socket
P6931A	25051240	NSCT-15P1030,Socket
P7503B	25052241, 25051312, 25051852 or 25052054	NSCT-8P2138, NSCT-8P1101, NSCT-8P1639 or NSCT-8P1841,Socket

SECONDARY CIRCUIT PC BOARD (NAETC-7411-1A/1B)

CIRCUIT NO.	PART NO.	DESCRIPTION
		Resistors
R9501	453530104	1ohm+/-5%,1/2W,Metal
R9502	453534794	0.47ohm+/-5%,1/2W,Metal
R9503	453532294	0.22ohm+/-5%,1/2W,Metal
R9521	453530224	2.2ohm+/-5%,1/2W,Metal
		Sockets
JL9501B	25051111	NSCT-7P898

SPEAKER TERMINAL PC BOARD (NAETC-7412-1A/1B)

CIRCUIT NO.	PART NO.	DESCRIPTION
		Diodes
D6600,D6601	223163,	1SS133,
D6604	223205 or 223222	1SS270A or WG713A
		Coils
L6800-L6804	231176	S-1.3C <O>
		Capacitors
C6600	374721034	0.01uF+/-5%,50V,Plastic
C6840-C6844	374721024	1000pF+/-5%,50V,Plastic <O>
		Relays
RL6600,RL6601	25065563,	NRL-2P5A-DC24-129,
RL6603,RL6604	25065517 or 25065586	NRL-2P5A-DC24-098 or NRL-2P5A-DC24-142
		Terminals
P6800	25060315	NTM-4PDMN246 <D>
	25060316	NTM-4PDMN247 <O>
P6801	25060317	NTM-4PDMN248
P6802	25060318	NTM-6PDMN249 <D>
	25060319	NTM-6PDMN250 <O>
		Sockets
JL6803B	25050269	NSCT-5P97
JL6804B	25050269	NSCT-5P97
JL6805B	25050268	NSCT-4P96

POWER AMPLIFIER PC BOARD (NAAF-7417-1A/1B/1C/1D/1E/1F)

CIRCUIT NO.	PART NO.	DESCRIPTION
		Transistors
Q6010-Q6014	2213284 or	2SC1740S-R or
Q6020-Q6024	2213285	2SC1740S-S
Q6030-Q6034	2203434 or 2203010	KTD2061-Y or 2SC5171
Q6040-Q6044	2203424 or 2203000	KTB1369-Y or 2SA1930
Q6070-Q6074	2215896, 2210755, 2210756, 2211732, 2211733 or 2215895	KTC3200-BL 2SC1775A-E, 2SC1775A-F, 2SC1845-F, 2SC1845-E or KTC3200-GR
Q6303	2215995, 2213354 or 2213355	KTA1267-GR, 2SA933S-R or 2SA933S-S
Q6601-Q6603	2215864, 2212115, 2213284 or 2213285	KTC3199-GR, 2SC2458-GR, 2SC1740S-R or 2SC1740S-S
Q6701,Q6702	2215896, 2210755, 2210756, 2211732, 2211733 or 2215895	KTC3200-BL, 2SC1775A-E, 2SC1775A-F, 2SC1845-F, 2SC1845-E or KTC3200-GR
Q6703	2215885, 2211792, 2211793 or 2215886	KTA1268-GR, 2SA992-F, 2SA992-E or KTA1268-BL
Q6901	2215864, 2212115, 2213284 or 2213285	KTC3199-GR, 2SC2458-GR, 2SC1740S-R or 2SC1740S-S
		Diodes
D6000-D6004	223163,	1SS133,
D6306,D6307	223205 or	1SS270A or
D6701,D6702	223222	WG713A
D6703,D6704	224470512	MTZJ5.1B
	224470512	MTZJ5.1B
D6903,D6904	22380130, 22380038 or 22380274	D5SBA20, RBV602 or RS603M
D6906	223163, 223205 or 223222	1SS133, 1SS270A or WG713A
		Capacitors
C6040-C6044	394684707	47uF,50V,Elect.
C6230-C6234	374724734	0.047uF+/-5%,50V,Plastic
C6701	394621017	100uF,6.3V,Elect.
C6704	394680107	1uF,50V,Elect.
C6706	394621017	100uF,6.3V,Elect.
C6901,C6902	3504351	10000uF,56V,Elect.
C6903	374721044	0.1uF+/-5%,50V,Plastic
C6904,C6905	374723344	0.33uF+/-5%,50V,Plastic
C6906,C6907	374721044	0.1uF+/-5%,50V,Plastic

NOTE: <D>: 120V model only
<O>: Except 120V model

PRINTED CIRCUIT BOARD-PARTS LIST 4

CIRCUIT NO.	PART NO.	DESCRIPTION	CIRCUIT NO.	PART NO.	DESCRIPTION
	Resistors			Resistors	
R6040-R6044	5210258	N06HR1KBC,Trimming	R901	4000206S or	⚠ RD1/2SPH-3.3M or
R6070-R6074	415471014	100ohm+/-5%,1/4W,NF carbon		431533355	⚠ RC1/2GFKUL-3.3M <D>
R6080-R6084	415470224	2.2ohm+/-5%,1/4W,NF carbon	R924	443528204	⚠ 82ohm+/-5%,1/2W,Metal oxide
R6090-R6094	415470224	2.2ohm+/-5%,1/4W,NF carbon		Relays	
R6100-R6104	4800071,	RSS2WK-0.22,	RL901	25065561,	⚠ NRL-1P5A-DC12-127,
	4500027 or	MPC708-2WK-0.22 or		25065508,	⚠ NRL-1P10A-DC12-093,
	4000131	RGC22-0.22 OHMK,Cement		25065515 or	⚠ NRL-1P5A-DC12-096 or
R6230-R6234	453630824	8.2ohm+/-5%,1W,Metal		25065526	⚠ NRL-1P5A-DC12-102
R6850,R6851	443523914	390ohm+/-5%,1/2W,Metal oxide		Switch	
	Relays		S902	25065437	⚠ NSS-22157P <R/T/Q>
RL6901,RL6902	25065561,	NRL-1P5A-DC12-127,		Fuse holders	
	25065508,	NRL-1P10A-DC12-093,	F901A,F901B	25052133	⚠ NSCT-1P2031<D/R/T/Q>
	25065515 or	NRL-1P5A-DC12-096 or	F902A,F902B	25052133	⚠ NSCT-1P2031<O>
	25065526	NRL-1P5A-DC12-102	F903A,F903B	25052133	⚠ NSCT-1P2031
	Fuse holders			Sockets	
F6901A,F6901B	25052133	NSCT-1P2031	P902	25051571	⚠ NSCT-2P1358 <D>
F6902A,F6902B	25052133	NSCT-1P2031		25051572	⚠ NSCT-2P1359 <P>
	Sockets			25052381	⚠ NSCT-2P2278 <R>
JL6402A	25051087	NSCT-3P874		25051572	⚠ NSCT-2P1359 <T/Q>
JL6803A	25051109	NSCT-5P896		25052115	⚠ NSCT-2P2013 <A>
JL6804A	25051109	NSCT-5P896	P931A	25051230	⚠ NSCT-5P1020
JL6805A	25051108	NSCT-4P895		Plug	
JL6951A	25051109	NSCT-5P896	P901A	25055675 or	⚠ NPLG-2P631 or
JL6951B	25051109	NSCT-5P896		25056028	⚠ NPLG-2P0978
	Plugs			TERMINAL PC BOARD (NAPS-7421-1A/1B/1C/1D/1E/1F)	
P6000~P6004	25056010	NPLG-5P0960		CIRCUIT NO. PART NO. DESCRIPTION	
P6011	25056014	NPLG-9P0964	JL6951B	25051109	NSCT-5P896,Socket
P6080~P6084	25055038	NPLG-2P29	JL6952B	25051109	NSCT-5P896,Socket
P6301	25055038	NPLG-2P29		VIDEO TERMINAL PC BOARD (NAVD-7422-1A/1B/1C/1D/1E/1F)	
P6931	25055711	NPLG-15P667		CIRCUIT NO. PART NO. DESCRIPTION	
P931	25055701	NPLG-5P657		ICs	
	Clamp		Q203	22241759	LA7956
P6801	260226	CP-2S	Q212,Q213	22241759	LA7956
	Bar		Q281	222740046R2	74HCU04F
P6903	27141806	BBL25		Transistors	
	Fuse labels		Q201,Q202	2213631 or	RN1241-A or
F6901C	29362800	T8AL250V <O>	Q207,Q208	2213632	RN1241-B
	POWER SWITCH PC BOARD (NASW-7418-1B/1C/1D/1E/1F)		Q204,Q209	2215995 or	KTA1267-GR or
	CIRCUIT NO. PART NO. DESCRIPTION			2213354	2SA933S-R
S906	25035702	⚠ NPS-121-L665P <O>	Q205,Q206	2215770 or	KRA102M or
	PRIMARY CIRCUIT PC BOARD (NAPS-7420-1A/1B/1C/1D/1E/1F)			2213510	DTA114ES
	CIRCUIT NO. PART NO. DESCRIPTION		Q210,Q211	2213631 or	RN1241-A or
	Transistors			2213632	RN1241-B
Q921	2215864,	KTC3199-GR,		Photo couplers	
	2212115,	2SC2458-GR,	U281,U282	24120083,	GP1FA550RZ,
	2213284 or	2SC1740S-R or		24120086 or	GP1FA551RZ or
	2213285	2SC1740S-S		24120095	TORX179
	Diodes			Coils	
D921-D924	22380260 or	RL1N4003 or	L281,L282	233454K220	NCH-1452 220K
	22380035	GP104003E	L283	233454M022	NCH-1452 022M
D925	223163,	1SS133,		NOTE: THE COMPONENTS IDENTIFIED BY MARK ⚠ ARE CRITICAL FOR RISK OF FIRE AND ELECTRIC SHOCK. REPLACE ONLY WITH PART NUMBER SPECIFIED.	
	223205 or	1SS270A or			
	223222	WG713A			
	Power transformer				
T902	2301381	⚠ NPT-1358D <D>		Note: <D>: 120V model only	
	2301382	⚠ NPT-1358P <P/A>		<P>: European model only	
	2301383	⚠ NPT-1358DG <R/T/Q/A>		<T>: Worldwide model only	
	Capacitors			<Q>: Hongkong model only	
C901	3500196S	⚠ RE275V-103M,IS		<A>: Australian model only	
C902	3300030	⚠ DE1307E472M-KH,IS <O>		<R>: Chinese model only	
C922	394662217	⚠ 220uF,35V,Elect.		<O>: Except 120V model	

PRINTED CIRCUIT BOARD-PARTS LIST

CIRCUIT NO.	PART NO.	DESCRIPTION
	Capacitors	
C201,C202	394680227	2.2uF,50V,Elect.
C203,C205	394641017	100uF,16V,Elect.
C204	394680227	2.2uF,50V,Elect.
C207,C209	394680227	2.2uF,50V,Elect.
C211,C215	394641017	100uF,16V,Elect.
C213	394680227	2.2uF,50V,Elect.
C217,C218	394680227	2.2uF,50V,Elect.
C221,C223	394644707	47uF,16V,Elect.
C225	394644707	47uF,16V,Elect.
C285,C288	394624707	47uF,6.3V,Elect.

	Terminals	
P201,P202	25045681	NPJ-10PDBY478
P203	25045682	NPJ-5PDBY479
P281	25045473	NPJ-1PDBL291
P282	25045504	NPJ-1PDBL319

	Socket	
P206B	25051239	NSCT-14P1029

	Plug	
P253A	25055236	NPLG-5P220

THERMAL DETECTOR CIRCUIT PC BOARD (NAETC-7424-1A/1B/1C/1D/1E/1F)

CIRCUIT NO.	PART NO.	DESCRIPTION
	Themistor	
R6380	4000153	PTH9M04BF222TS2F333
	Sockets	
JL6402B	25051087	NSCT-3P874

MAIN MICROPROCESSOR-CONNECTION DIAGRAM

1

2

3

4

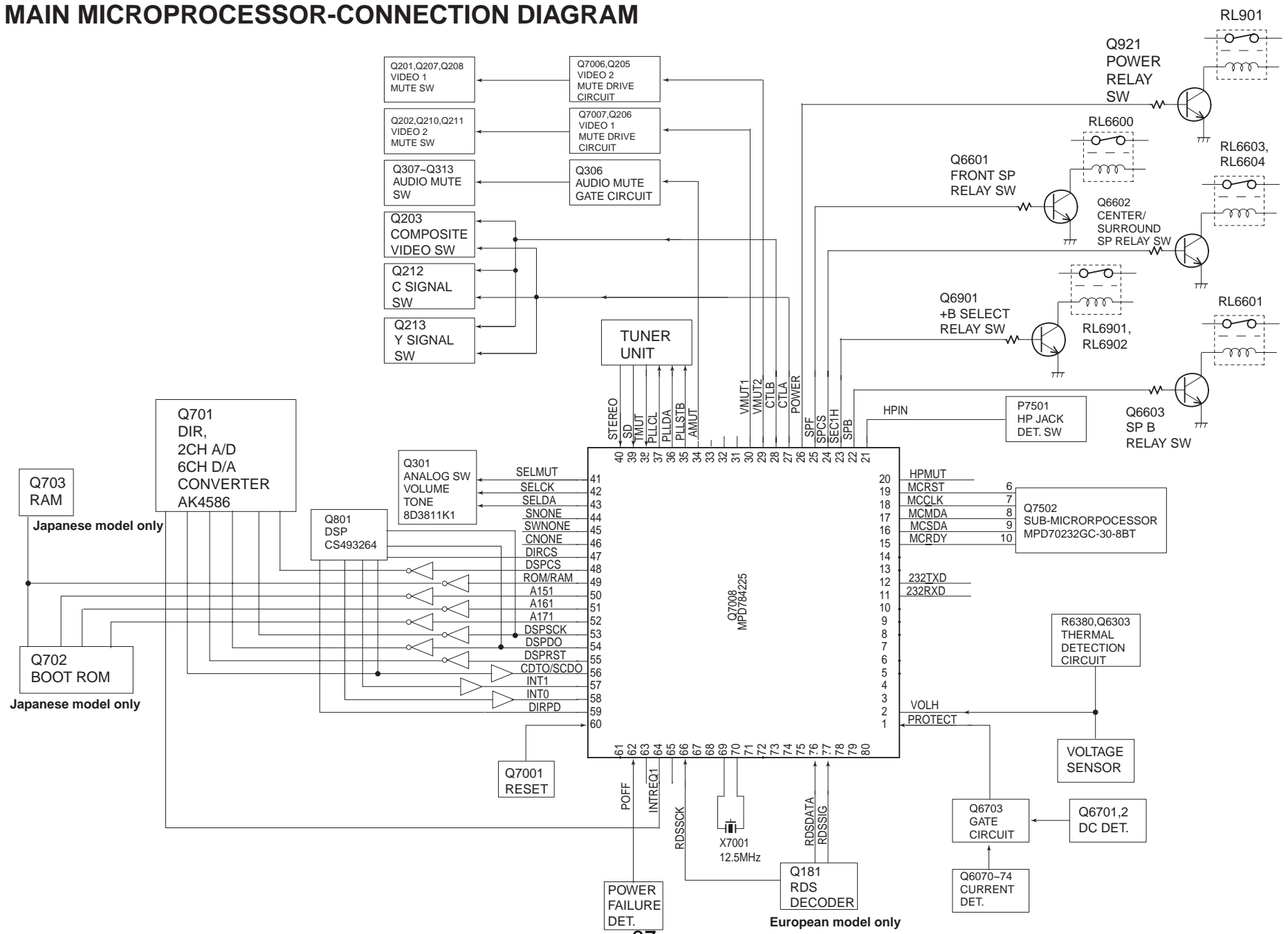

European model only

SUB-MICROPROCESSOR CONNECTION DIAGRAM

1

2

3

4

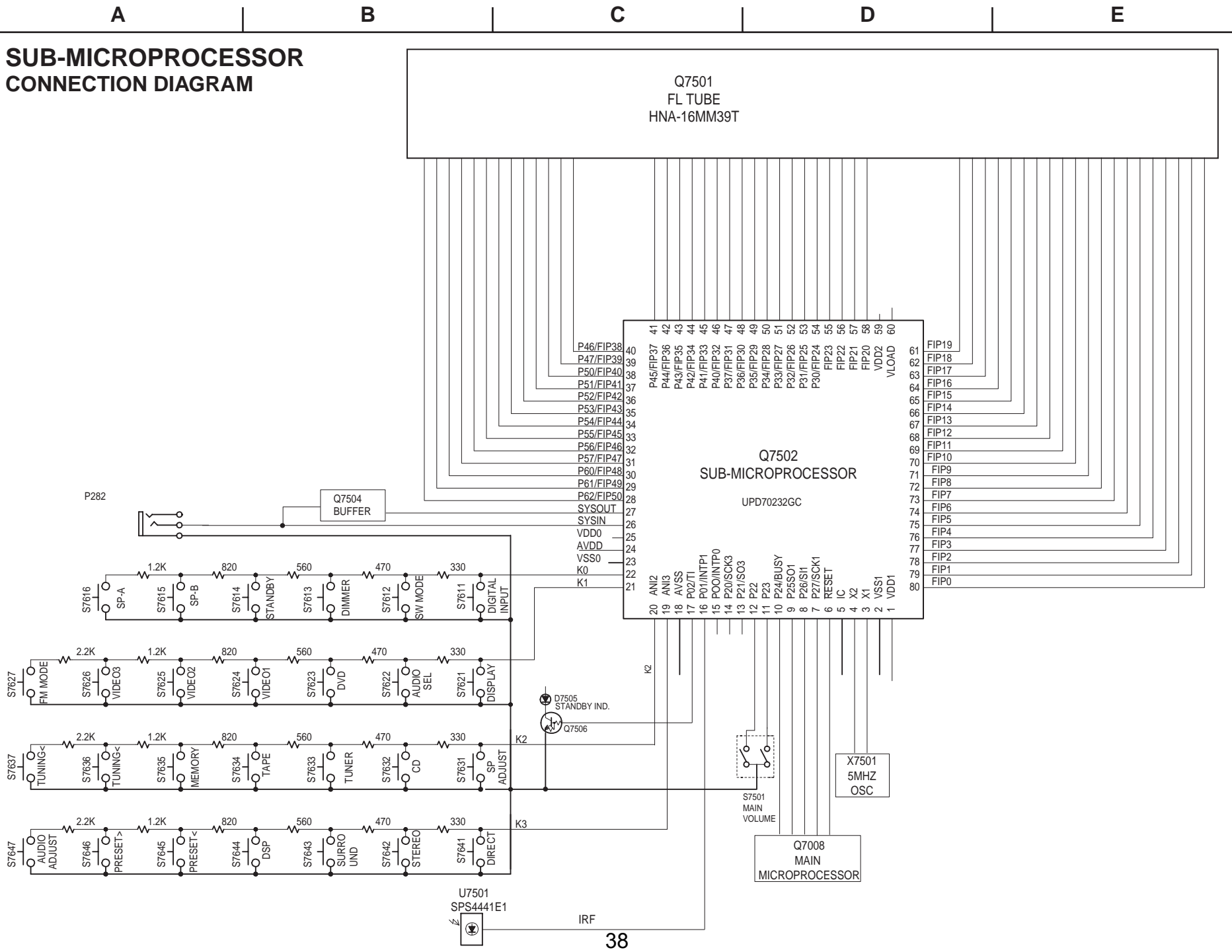

TERMINAL DESCRIPTION

MAIN MICROPROCESSOR

No.	Terminal	I/O	Description
1	PROTECT	I	Protection circuit detection input terminal
2	VOLH	I	Power amplifier voltage detection terminal.
3	BAND	I	Region setting input terminal.
11	232TXD		Not used.
12	232RXD		Not used.
15	MCRDY	I	Data ready detection input terminal from the sub microprocessor.
16	MCSDa	I	Data input terminal from the sub microprocessor.
17	MCMDA	O	Data output terminal to the sub microprocessor.
18	MCCLK	O	Serial clock output terminal to the sub microprocessor
19	~MCRST	O	Reset signal output terminal to the sub microprocessor
20	HPMUT	O	Muting control output terminal for headphone amplifier.
21	HPIN	I	Input terminal to detect the connection of headphone
22	SPBRL	O	Speaker B relay control output terminal.
23	SEC1H	O	Voltage +/-B control output terminal.
24	SPACSR	O	Speaker relay control output terminal for center and surround channels
25	SPAFRL	O	Speaker relay A control output terminal for front channels
26	POWERRL	O	Power source relay control output terminal
27	VCTRLA	O	Control signal A output terminal for the video selector switch
28	VCTRLB	O	Control signal B output terminal for the video selector switch
29	VMUT2	O	Muting control output terminal for the video section 2
30	VMUT1	O	Muting control output terminal for the video section 1
34	AMUT	O	Audio muting control output terminal
35	PLLSTB	O	Strobe signal output terminal to PLL IC
36	PLLSDO	O	Serial data output terminal to PLL IC
37	PLLCLK	O	Serial clock output terminal to PLL IC
38	TUMUT	O	Muting control output terminal for the tuner section
39	~SD	I	Broadcast detection input terminal more than a muting level.
40	~STEREO	I	FM stereo broadcast detection input terminal
41	SELMUT	O	Muting control output terminal for selector, volume and tone IC BD3811.
42	SELCLK	O	Serial clock output terminal of IC BD3811.
43	SELSDO	O	Serial data and latch signal output terminal for IC BD3811
44	SNONE	O	Not used.
45	SWNONE	O	Not used.
46	CNONE	O	Not used.
47	~DIRCS	O	Chip select signal output terminal to DIR IC AK4586
48	~DSPCS	O	Chip select signal output terminal to DSP IC.
49	~ROM/RAM	O	ROM/RAM select terminal. Not used.
50	ADDR151	O	DSP boot ROM address 15 select terminal. Not used.
51	ADDR161	O	DSP boot ROM address 16 select terminal. Not used.
52	ADDR171	O	DSP boot ROM address 17 select terminal. Not used.
53	DSPCLK	O	Serial clock output terminal for DIR and DSP ICs.
54	DSPSDO	O	Serial data output terminal for DIR and DSP ICs.
55	~DSPRST	O	Reset signal output terminal to DSP IC.
56	CDTO/SCDO	I	Serial data input terminal from DIR and DSP ICs.
57	INT1	I	Input terminal to detect the status of DIR IC.
58	INT0	I	Input terminal to detect the unlock of DIR IC.
59	~DIRPD	O	Power down terminal to DIR and CODEC ICs.
60	RESET	I	Reset input terminal
62	POFF	I	Power failure detection input terminal
64	~INTREQ/~AB	I/O	Interrupter input terminal from DSP IC.
66	~RDSCCLK	I	RDS clock input terminal (European model only)
69	X2		Connect the ceramic oscillator 12.5MHz.
70	X1		Connect the ceramic oscillator 12.5MHz.
71	TEST/VPP		Test terminal.
72	XT2		Not used.
73	XT1		Not used.
76	RDSDATA	I	Data input terminal of RDS broadcast (European model only)
77	RDSSIG	I	Input terminal to check the signal of RDS broadcast (European model only)

TERMINAL DESCRIPTION

SUB MICROPROCESSOR

Pin No.	Symbol	I/O	Description	Pin No.	Symbol	I/O	Description
1	VDD		Power supply terminal. Connect to 5V.	41	P22	O	Segment output terminal of P22.
2	VSS		Ground terminal.	42	P21	O	Segment output terminal of P21.
3	X1		Ceramic oscillator connection terminals for main system.	43	P20	O	Segment output terminal of P20.
4	X2		Connect the 5MHz ceramic oscillator between #3 and #4.	44	P19	O	Segment output terminal of P19.
5	IC/VPP		Internal connection terminal	45	P18	O	Segment output terminal of P18.
6	~RESET	I	System reset signal input terminal.	46	P17	O	Segment output terminal of P17.
7	SUBCL/SCK	I	Clock input terminal to transmit the signal from main microprocessor.	47	P16	O	Segment output terminal of P16.
8	SUBDO/SDI	I	Data input terminal to transmit the signal from main microprocessor.	48	P15	O	Segment output terminal of P15.
9	SUBDI/SDD	O	Data output terminal to transmit the signal to main microprocessor.	49	P14	O	Segment output terminal of P14.
10	SUBLDY	O	Data ready output terminal to transmit to the main microprocessor.	50	P13	O	Segment output terminal of P13.
11	VBJ	I	Pulse input terminal from the rotary encoder of volume.	51	P12	O	Segment output terminal of P12.
12	VAJ	I	Pulse input terminal from the rotary encoder of volume.	52	P11	O	Segment output terminal of P11.
13	SSCBJ	I	Not used.	53	P10	O	Segment output terminal of P10.
14	SSCAJ	I	Not used.	54	P9	O	Segment output terminal of P9.
15	~IRIN	I	Not used.	55	P8	O	Segment output terminal of P8.
16	~IRF	I	Signal input terminal from the remote controller.	56	P7	O	Segment output terminal of P7.
17	STBYLED	O	Standby LED control output terminal.	57	P6	O	Segment output terminal of P6.
18	AVSS		Ground terminal for A/D converter.	58	P5	O	Segment output terminal of P5.
19	K3	I	Operation key connection terminal.	59	VDD2		Power supply terminal. Apply +5V.
20	K2	I	Operation key connection terminal.	60	VLOAD		Negative power supply terminal of FL controller.
21	K1	I	Operation key connection terminal.	61	P4	O	Segment output terminal of P4.
22	K0	I	Operation key connection terminal.	62	P3	O	Segment output terminal of P3.
23	VSS0		Ground terminal	63	P2	O	Segment output terminal of P2.
24	AVDD		Power supply terminal for A/D converter.	64	P1	O	Segment output terminal of P1.
25	VDDD		Power supply terminal. Apply +5V.	65	16G	O	Grid output terminal of 16G.
26	~SYSIN	I	System code input terminal.	66	15G	O	Grid output terminal of 15G.
27	~SYSOUT	O	System code output terminal.	67	14G	O	Grid output terminal of 14G.
28	P35	O	Segment output terminal of P35.	68	13G	O	Grid output terminal of 13G.
29	P34	O	Segment output terminal of P34.	69	12G	O	Grid output terminal of 12G.
30	P33	O	Segment output terminal of P33.	70	11G	O	Grid output terminal of 11G.
31	P32	O	Segment output terminal of P32.	71	10G	O	Grid output terminal of 10G.
32	P31	O	Segment output terminal of P31.	72	9G	O	Grid output terminal of 9G.
33	P30	O	Segment output terminal of P30.	73	8G	O	Grid output terminal of 8G.
34	P29	O	Segment output terminal of P29.	74	7G	O	Grid output terminal of 7G.
35	P28	O	Segment output terminal of P28.	75	6G	O	Grid output terminal of 6G.
36	P27	O	Segment output terminal of P27.	76	5G	O	Grid output terminal of 5G.
37	P26	O	Segment output terminal of P26.	77	4G	O	Grid output terminal of 4G.
38	P25	O	Segment output terminal of P25.	78	3G	O	Grid output terminal of 3G.
39	P24	O	Segment output terminal of P24.	79	2G	O	Grid output terminal of 2G.
40	P23	O	Segment output terminal of P23.	80	1G	O	Grid output terminal of 1G.

ADJUSTMENT AND CONFIRMATION PROCEDURES 1

Idling current adjustment

Before Idling adjustment, turn the trimming resistors R6040,R6041,R6042,R6043 and R6044 to counter clockwise. Connect the DC voltmeter to sockets P6080,P6081,P6082,P6083 and P6084.

After turn POWER to ON, adjust the trimming resistors R6040 and R6041 so that the reading of voltmeter becomes 2.5 mV. (Front channels)

Adjust the trimming resistors R6042, R6043 and R6044 so that the reading of voltmeter becomes 1.5 mV. (Center and surround channels)

After adjustment, attach the top cover.

Confirm the voltage of points above after about five minutes.

Front and center channels

When less than 7.0 mV, readjust the resistors above so that the voltage becomes 7.0 mV.

When 7.0 mV to 9.0 mV, you are not necessary to adjust.

When more than 9.0 mV, readjust the resistors above so that the voltage becomes 9.0 mV.

Surround channels

When less than 4.0 mV, readjust the resistors above so that the voltage becomes 4.0 mV.

When 4.0 mV to 6.0 mV, you are not necessary to adjust.

When more than 6.0 mV, readjust the resistors above so that the voltage becomes 6.0 mV.

Note: No load and No signal

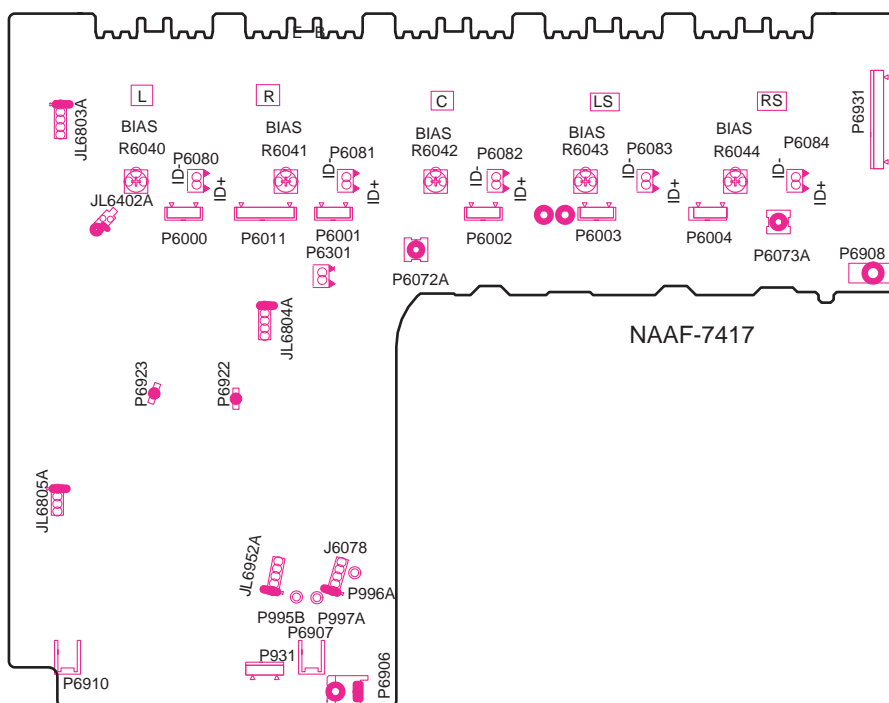

Confirmation of protection circuit

1. Confirmation of operation of speaker relay

Confirm that the speaker relays turn ON approximate. 5 seconds after the power switch is turned ON.

Confirm that the speaker relays turn OFF immediately after the power switch is turned OFF.

2. Confirmation of DC detection circuit

Press and hold down CD button, then press STANDBY/ON and DISPLAY buttons to set the unit to "TEST-1" mode.

After "TEST-1" on the FL tube light on, press VIDEO 1 button to set the unit to "TEST-1-00".

Apply DC 1.5 to 3V to DVD INPUT terminal with no load.

Confirm that the speaker relay turns OFF.

Apply DC -1.5 to -3V to DVD INPUT terminal with no load.

Confirm that the speaker relay turns OFF.

Caution: Don't apply DC voltage more than 1 sec..

ADJUSTMENT AND CONFIRMATION PROCEDURES 2

3. Confirmation of Current detection circuit

Set the unit to "TEST-1-00".

Connect the differentiating circuit and apply the 200Hz square signal to MULTI CHANNEL INPUT terminal of each channel.

Adjust the attenuator or Volume so that the output level becomes 35V p-p.

Confirm that "Protect" indicator does not turn OFF when a 3.0 ohm load is connected.

Confirm that "Protect" indicator lights on when a 1.5 ohm load is connected.

Caution: Don't continue more than 3 seconds.

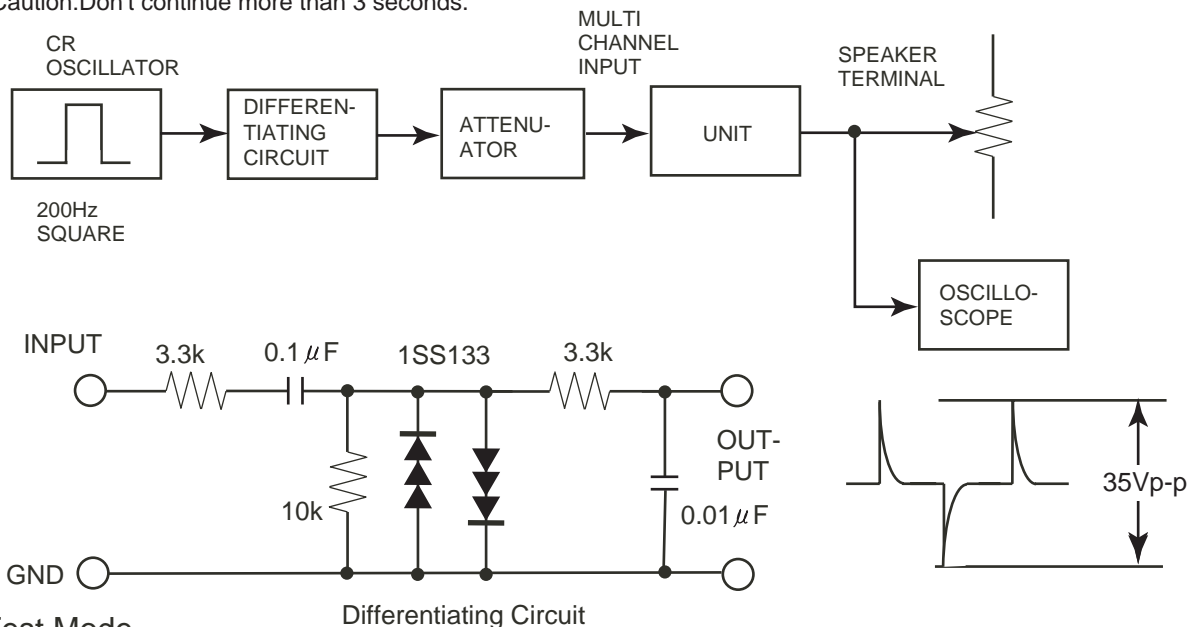

Test Mode

1. Turn POWER button on.
2. Press and hold down CD button, then press STANDBY/ON button.
3. After "TEST-" on the FL tube is displayed, press CD button to set the unit to the test mode of FL tube.

Note: DVD:TEST-1 VIDEO 1 :TEST-2 SP-A: UP
VIDEO 2 :TEST-3 VIDEO 3:TEST-4 SP-B: DOWN

Test mode of FL tube

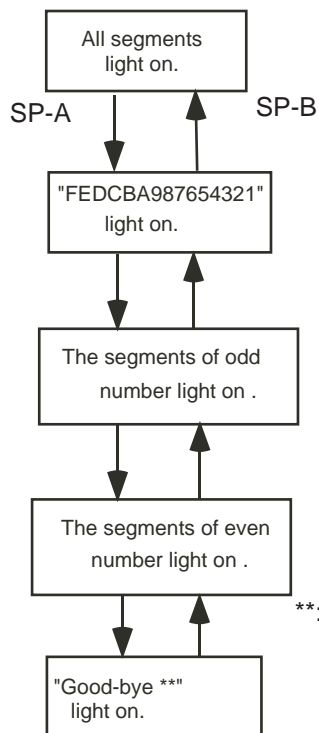

** : Region US:U.S.A.
EU:Europe
WR:Other models

Press POWER button to finish the test mode of FL tube.

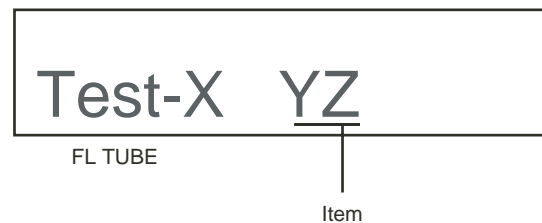

Confirmation of voltage sensor

1. Set the unit to TEST-3-2.
2. Apply the signal 1kHz, -15dBV to the MULTI-CH input. Confirm that the FM STEREO is displayed. Confirm the all channels except SUBWOFFER.
3. When connect the resistor 2.7 kohm/1 W between the terminals COM and TH1 of P6301, confirm that "FM STEREO" light on.
Note: No input signal.
4. When set the unit to "TEST-4-30, confirm that the speaker relays of RL6901 and RL6902 turn off.
Note: No input signal.

PACKING PROCEDURES

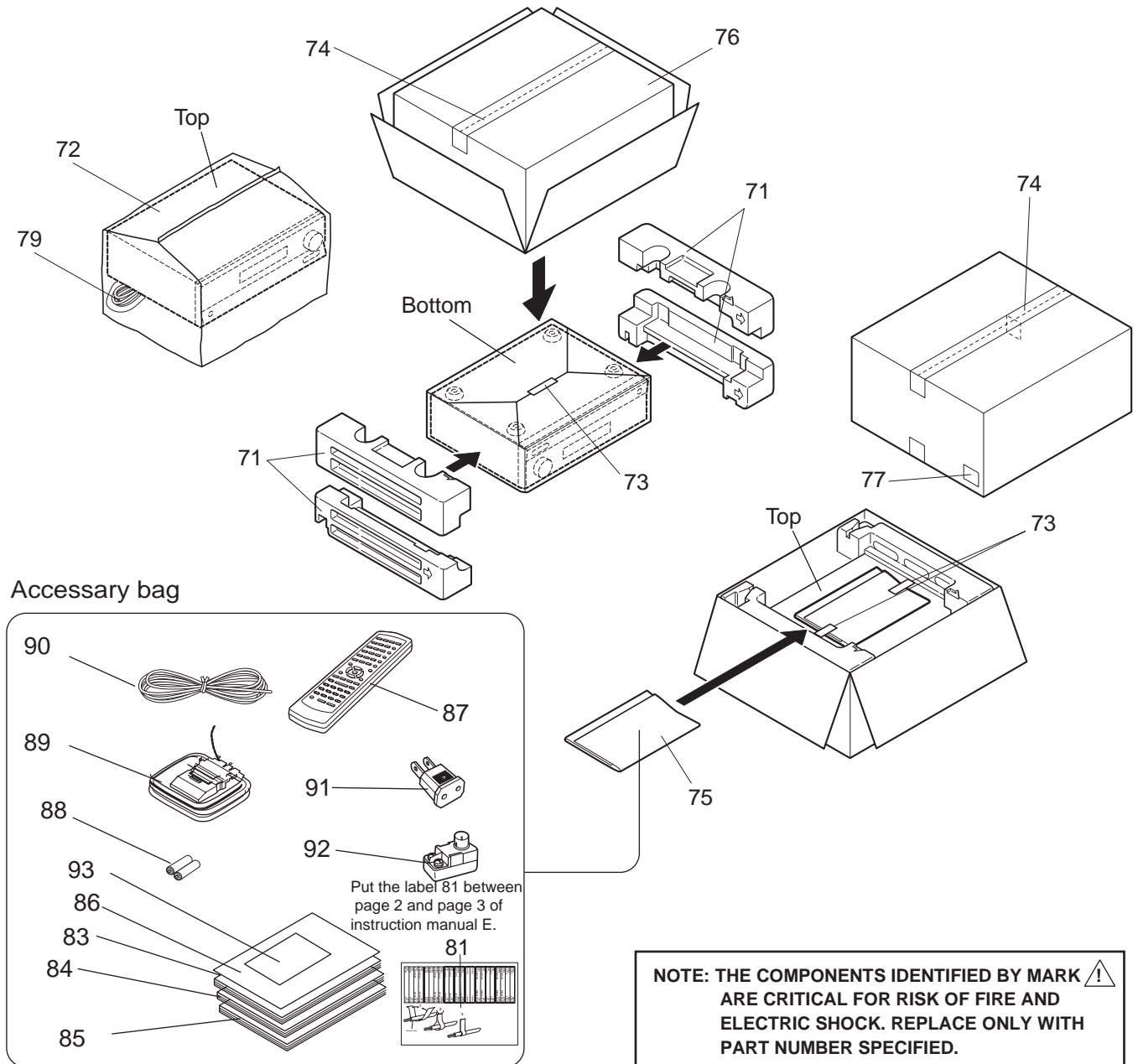

NOTE: THE COMPONENTS IDENTIFIED BY MARK ARE CRITICAL FOR RISK OF FIRE AND ELECTRIC SHOCK. REPLACE ONLY WITH PART NUMBER SPECIFIED.

REF.NO.	PART NO.	DESCRIPTION	REF.NO.	PART NO.	DESCRIPTION
71	29092044	Pad	79	29100097-1A	350*250,Poly bag for power supply cord <O>
72	29100034-1A	850*650,Poly bag	81	29363059A	Label,cable
73	29110149	Tape, cellophane	83	29343286A	Instruction manual E
74	29110148	PP tape	84	29343288A	Instruction manual GDSW <P>
75	29100201	350*200*W250,Polybag		29343290A	Instruction manual CT/CS <T/R/Q>
76	29053869C	Carton box <D>	85	29343289A	Instruction manual FSI <P/C>
	29053870C	Carton box <P>	86	29343287A	Instruction manual,digest <D>
	29053871C	Carton box <S>	87	24140478	RC-478M,Remote controller <D/C>
	29053872B	Carton box <G>		24140479	RC-479S,Remote controller <O>
	29053893B	Carton box <C/A/T>	88	3010054	UM-3,Two batteries
77	29363052	Label EAN <P>	89	232140	NMA-3057,AM loop antenna
	29363053	Label EAN <S>	90	292115	FM antenna <P/A/T/K/Q/R>
	29363055	Label UPC <D/C>		292142	FM antenna <D/C>
	29363099	Label EAN <A/T>	91	25065462	YAE21-0237,Antenna adaptor <T/A/R/Q/K>
	29363100	Label EAN <G>	92	25056005	CV-K-1,Conversion plug <T>
			93	29365090A	Warranty card <D>

Note:
 : Black model only
 <G>: Golden model only
 <S>: Silver model only
 <D>: 120V model only
 <P>: European model only
 <T>: Worldwide model only
 <K>: Korean model only
 <A>: Australian model only
 <R>: Chinese model only
 <C>: Canadian model only
 <Q>: Hongkong model only
 <O>: Except 120V model

ONKYO CORPORATION

Sales & Product Planning Div. : 2-1, Nisshin-cho, Neyagawa-shi, OSAKA 572-8540, JAPAN
Tel: 072-831-8111 Fax: 072-833-5222

ONKYO U.S.A. CORPORATION

18 Park Way, Upper Saddle River, N.J. 07458, U.S.A.
Tel: 201-785-2600 Fax: 201-785-2650 E-mail: onkyo@onkyousa.com

ONKYO EUROPE ELECTRONICS GmbH

Liegnitzerstrasse 6, 82194 Grobenzell, GERMANY
Tel: +49-8142-4401-0 Fax: +49-8142-4401-555 E-mail: info@onkyo.de

ONKYO CHINA LIMITED

Units 2102-2107, Metroplaza Tower I, 223 Hing Fong Road, Kwai Chung,
N.T., HONG KONG Tel: 852-2429-3118 Fax: 852-2428-9039

