

ONKYO SERVICE MANUAL

AV RECEIVER MODEL TX-SR501/E

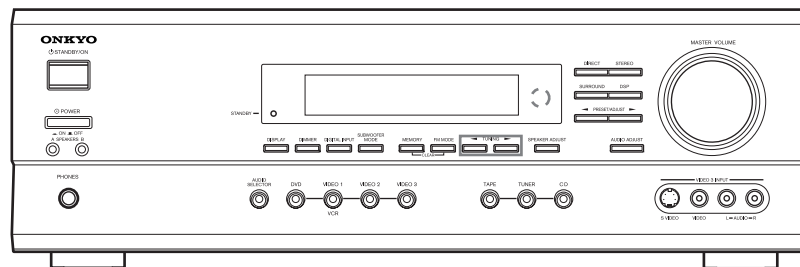

Black, Golden and Silver models

BMDD,BMDC	120V AC, 60Hz
BMPP,SMPP,BMPA,GMPA	230-240V AC, 50Hz
BMWT,GMWT,GMWR,GMWQ	120/220-230V AC, 50/60Hz
GMGK	220V AC, 50Hz

SAFETY-RELATED COMPONENT WARNING!!

COMPONENTS IDENTIFIED BY MARK  ON THE SCHEMATIC DIAGRAM AND IN THE PARTS LIST ARE CRITICAL FOR RISK OF FIRE AND ELECTRIC SHOCK. REPLACE THESE COMPONENTS WITH ONKYO PARTS WHOSE PART NUMBERS APPEAR AS SHOWN IN THIS MANUAL.

MAKE LEAKAGE-CURRENT OR RESISTANCE MEASUREMENTS TO DETERMINE THAT EXPOSED PARTS ARE ACCEPTABLY INSULATED FROM THE SUPPLY CIRCUIT BEFORE RETURNING THE APPLIANCE TO THE CUSTOMER.

Specifications

AMPLIFIER SECTION

Continuous Average Power output (FTC)

All channels:

65 watts per channel min. RMS at 8 Ω, 2 channels driven from 20 Hz to 20 kHz with no more than 0.08% total harmonic distortion.

80 watts per channel min. RMS at 6 Ω, 2 channels driven from 1 kHz with no more than 0.1% total harmonic distortion.

Continuous Power output (DIN)

85 watts × 2 at 6 Ω

Maximum Power output (EIAJ)

115 watts × 2 at 6 Ω

Dynamic power output:

160 watts × 2 at 3 Ω

125 watts × 2 at 4 Ω

85 watts × 2 at 8 Ω

Total Harmonic Distortion:

0.08% at rated power

0.08% at 1 watt output

IM Distortion:

0.08% at rated power

0.08% at 1 watt output

Damping Factor:

60 at 8 Ω

Input Sensitivity and Impedance

DIGITAL INPUT (OPTICAL 1, 2):

0.5 V_{p-p}, 75 Ω

DIGITAL INPUT (COAXIAL):

0.5 V_{p-p}, 75 Ω

LINE (CD, VIDEO 1, 2, 3, TAPE):

200 mV, 47 kΩ

Multichannel Input

(DVD FRONT L/C/R, SURR L/R):

200 mV, 47 kΩ

(SUBWOOFER):

36 mV, 47 kΩ

Output Level and Impedance

Rec out (TAPE, VIDEO 1):

200 mV, 470 Ω

Pre out (SUBWOOFER):

1 V, 470 Ω

Frequency Response:

10 Hz to 100 kHz,

+1/-3 dB (Direct mode)

Tone Control

Bass:

±12 dB at 50 Hz

Treble:

±12 dB at 20 kHz

Signal-to-Noise Ratio:

CD/TAPE: 100 dB

(IHF-A, Direct mode)

Muting:

-50 dB

VIDEO SECTION

Input Sensitivity and Impedance

VIDEO (DVD, VIDEO 1, 2, 3):

1 V_{p-p}, 75 Ω

S VIDEO (DVD, VIDEO 1, 2, 3):

1 V_{p-p}, 75 Ω (Y)

COMPONENT VIDEO 1, 2:

0.28 V_{p-p}, 75 Ω (C)

1 V_{p-p}, 75 Ω (Y)

0.7 V_{p-p}, 75 Ω (P_B, P_R)

Output Level and Impedance

VIDEO (VIDEO 1, 2, MONITOR):

1 V_{p-p}, 75 Ω

S VIDEO (VIDEO 1, 2, MONITOR):

1 V_{p-p}, 75 Ω (Y)

0.28 V_{p-p}, 75 Ω (C)

COMPONENT VIDEO OUT:

1 V_{p-p}, 75 Ω (Y)

0.7 V_{p-p}, 75 Ω (P_B, P_R)

TUNER SECTION

FM

Tuning Range

North American models:

87.50-108.00 MHz (100 kHz steps)

Other models:

87.50-108.00 MHz (50 kHz steps)

Usable Sensitivity

Mono:

11.2 dBf, 1.0 μV (75 Ω, IHF)

0.9 μV (75 Ω, DIN)

Stereo:

17.2 dBf, 2.0 μV (75 Ω, IHF)

23 μV (75 Ω DIN)

50 dB Quietening Sensitivity

Mono:

17.2 dBf, 2.0 μV (75 Ω)

Stereo:

37.2 dBf, 20.0 μV (75 Ω)

Capture Ratio:

2.0 dB

Image Rejection Ratio

North American models:

40 dB

Other models:

85 dB

IF Rejection Ratio:

90 dB

Signal-to-Noise Ratio

Mono:

76 dB

Stereo:

70 dB

Alternate Channel Attenuation:

55 dB

Selectivity:

50 dB (DIN)

AM Suppression Ratio:

50 dB

Total Harmonic Distortion

Mono:

0.2%

Stereo:

0.3%

Frequency Response:

30 Hz-15 kHz, -1.0 dB

Stereo Separation:

45 dB at 1 kHz

30 dB at 100 Hz-10 kHz

AM

Tuning Range

North American models:

530-1,710 kHz (10 kHz steps)

European & Australian models:

522-1,611 kHz (9 kHz steps)

Worldwide models:

522-1,611 kHz (9 kHz steps), or

530-1,710 kHz (10 kHz steps)

Usable Sensitivity:

30 μV

Image Rejection Ratio:

40 dB

IF Rejection Ratio:

40 dB

Signal-to-Noise Ratio:

40 dB

Total Harmonic Distortion:

0.7%

GENERAL

Power Supply and Power Consumption:

AC 120 V, 60 Hz

4.6 A

AC 230-240 V, 50 Hz

370 W

AC 220-230 V and 120 V switchable, 50/60 Hz

370 W

Dimensions (W × H × D):

17-1/8" × 5-7/8" × 14-13/16"

435 × 150 × 376 mm

Weight

North American models:

19.6 lbs., 8.9 kg

European models:

21.6 lbs., 9.8 kg

Other models:

21.8 lbs., 9.9 kg

REMOTE CONTROL

Transmitter:

Infrared

Signal range:

Approx. 16 ft., 5 meters

Power supply:

Two "AA" batteries (1.5 V × 2)

Specifications and features are subject to change without notice. Power supply and voltage vary depending on the area in which the unit is purchased.

SERVICE PROCEDURES

1. Replacing the fuses



This symbol located near the fuses indicates that the fuse used is fast operating type. For continued protection against fire hazard, replace with same type fuse. For fuse rating refer to the marking adjacent to the symbol.



Ce symbole indique que le fusible utilise est a rapide. Pour une protection permanente, n'utiliser que fusibles de meme type. Ce dernier est la qu le present symbol est appse.

CIRCUIT NO.	PART NO.	DESCRIPTION
F6901,F6902	252198 or	8A-UL or
	252261	8A-T/UL-ST2 <D>
	252099	8A-EAK ,Fuse <O>
F901	252166 or	6.3A-UL/T-237 or
	252260	6.3A-T/UL-ST2,Fuse <D/T/Q/R>
F902	252076,	3.15A-SE-EAK,
	252242 or	3.15A-SE-TL250V or
	252276	3.15A-SE-TL250V <O>
F903	252075,	2.5A-SE-EAK,
	252241 or	2.5A-SE-TL250V or
	252275	2.5A-SE-TL250V,Fuse <O>

Note: <D>:120V model only
 <O>: Other models except 120V model
 <T>: Asian model only for 230V
 <R>: Chinese model only
 <Q>: Hongkong model only

2. To initialize the unit

This device employs a microprocessor to perform various functions and operations. If interference generated by an external power supply, radio wave, or other electrical source results in accident which causes the specified operations and functions to operate abnormally.

To perform a result, please follow the procedure below.

- 1.Press and hold down the VIDEO-1 button, then press the STANDBY/ON button.
- 2.After "CLEAR" is displayed, the preset memory and each mode stored in the memory, such as surround, are initialized and will return to the factory setting.
3. Unplug the power supply cord.

3. Safety-check out

(U.S.A. model only)

After correcting the original service problem, perform the following safety check before releasing the set to the customer.

Leakage Current Check

Measure leakage current to a known earth ground(water pipe, conduit, etc.) by connecting a leakage current tester between the earth ground and exposed metal parts of the appliance (input/output terminals, screwheads,metal overlays, etc.). Plug the power supply cord directly into a 120V AC 60 Hz outlet and turn Standby switch on. Any current measured must not exceed 0.5mA.

4.Setting the voltage selector (Worldwide models only)

Worldwide models are equipped with a voltage selector to conform with local power supplies. Be sure to set this switch to match the voltage of the power supply in your area before plugging in the unit.

Determine the proper voltage for your area: 220-230 V or 120 V. If the preset voltage is not correct for your area, insert a screwdriver into the groove in the switch. Slide the switch all the way to the upper (120 V) or to the lower (220-230 V), whichever is appropriate.

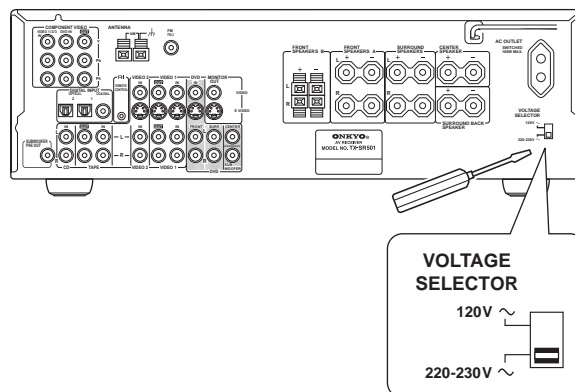

5.Setting the AM tuning step frequency

(Worldwide models only)

If you are using the Worldwide model (i.e., your TX-SR501/ TX-SR501E has a VOLTAGE SELECTOR on the rear panel), you need to set the AM tuning interval for compatibility with AM broadcasts in your particular country. The initial setting is 9 kHz.

North America: 10 kHz

Other countries: 9 kHz

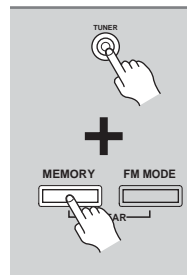

To set the AM tuning interval, while holding down the [TUNER] button, press the [MEMORY] button.

Note:

All presets are deleted when you change this setting.

Rear Panel

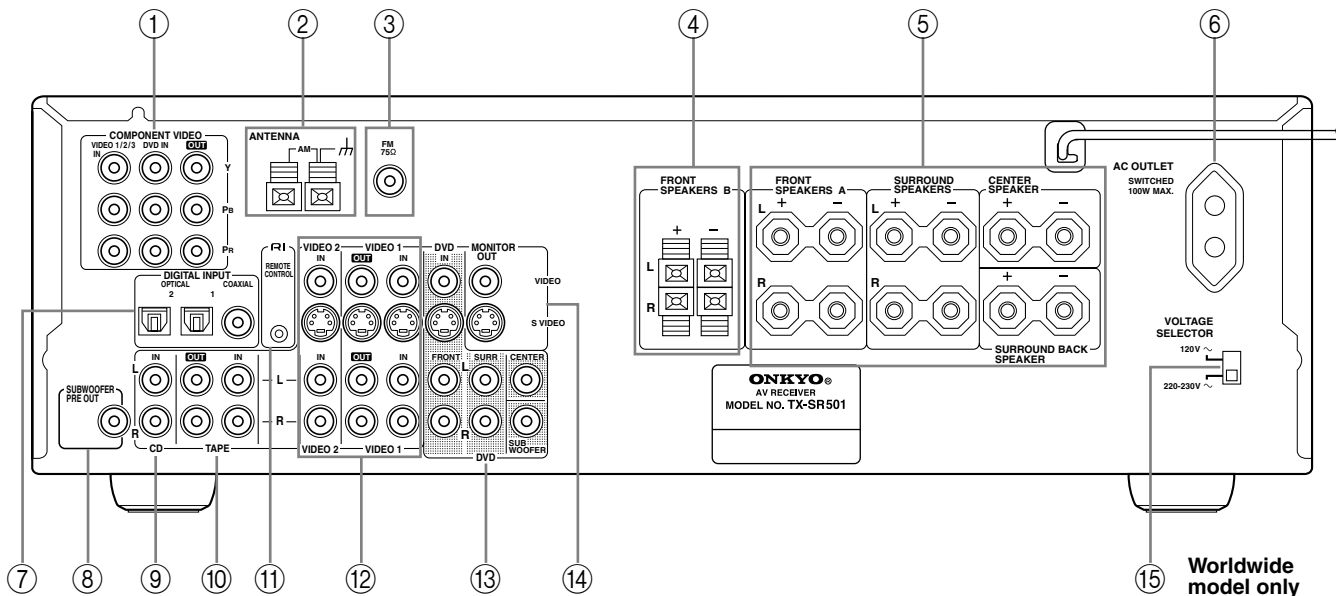
① **COMPONENT VIDEO (10, 12, 14, 16)**

These RCA/phono connectors can be used to connect a TV, DVD player, or other AV component with component video inputs and outputs.

② **AM ANTENNA (22, 23)**

These push terminals are for connecting an AM antenna.

③ **FM ANTENNA (22, 23)**

This connector is for connecting an FM antenna.

④ **FRONT SPEAKERS B (21)**

These push terminals are for connecting speaker set B.

⑤ **FRONT SPEAKERS A, SURROUND SPEAKERS, CENTER SPEAKER & SURROUND BACK SPEAKER (21)**

These terminal posts are for connecting speaker set A, including the front, surround, center, and surround-back speakers. They accept bare wires or banana plugs (European models don't accept banana plugs).

⑥ **AC OUTLET (11)**

This switched AC outlet can be used to supply power to another AV component. The connector type depends on the country in which you purchased your TX-SR501/TX-SR501E.

⑦ **DIGITAL INPUT OPTICAL 1, 2 & COAXIAL (10, 13, 14, 16–18)**

These optical and coaxial connectors can be used to connect a CD, DVD, or LD (laser disc) player, or other AV component with digital outputs.

⑧ **SUBWOOFER PRE OUT (21)**

This RCA/phono connector can be used to connect an active subwoofer.

⑨ **CD IN (10, 17)**

These RCA/phono connectors can be used to connect a CD player with analog outputs.

⑩ **TAPE IN/OUT (10, 17, 18)**

These RCA/phono connectors can be used to connect a cassette recorder, MiniDisc recorder, or other recorder with analog inputs and outputs.

⑪ **RI (19)**

This **RI** (Remote Interactive) connector can be connected to the **RI** connector on another Onkyo AV component, for example, a CD player, DVD player, or cassette recorder. The TX-SR501/TX-SR501E's remote controller can then be used to control that component. To use **RI**, you must make an analog RCA/phono connection between your TX-SR501/TX-SR501E and the other AV component, even if they are connected digitally.

⑫ **VIDEO 1 IN/OUT & VIDEO 2 IN (10, 14–16, 39)**

These connectors can be used to connect a VCR or other AV component. There are RCA/phono connectors for connecting to stereo analog audio inputs and outputs, and S-Video and composite video (RCA/phono) connectors for connecting to video inputs and outputs.

⑬ **DVD IN/MULTI CH INPUT (10, 12, 13)**

The FRONT, SURR, CENTER, and SUBWOOFER RCA/phono connectors can be used to connect AV components with multiple analog audio outputs, including DVD players with individual 5.1 surround analog outputs. There's an S-Video input and composite video (RCA/phono) input for connecting the video signal.

⑭ **MONITOR OUT (10, 12)**

These S-Video and composite video (RCA/phono) outputs can be connected to the video input on your TV or projector.

⑮ **VOLTAGE SELECTOR (Worldwide model only) (5)**

This voltage selector provides compatibility with power systems around the world.

Tip:

A turntable with a built-in preamp can be connected to a pair of unused TX-SR501/TX-SR501E analog inputs. To connect a turntable without a built-in preamp, you'll need a commercially available phono preamp. See pages 17 and 18 and the instructions supplied with your phono preamp and turntable for more information.

Front Panel

North American Model

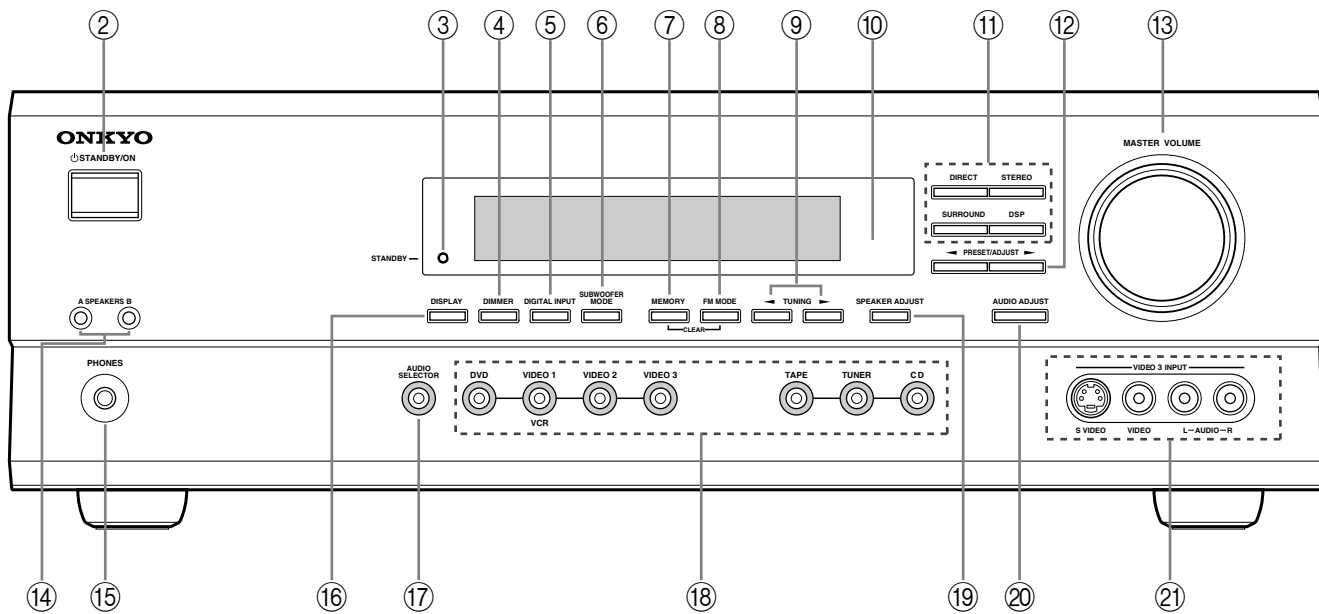

Other Models

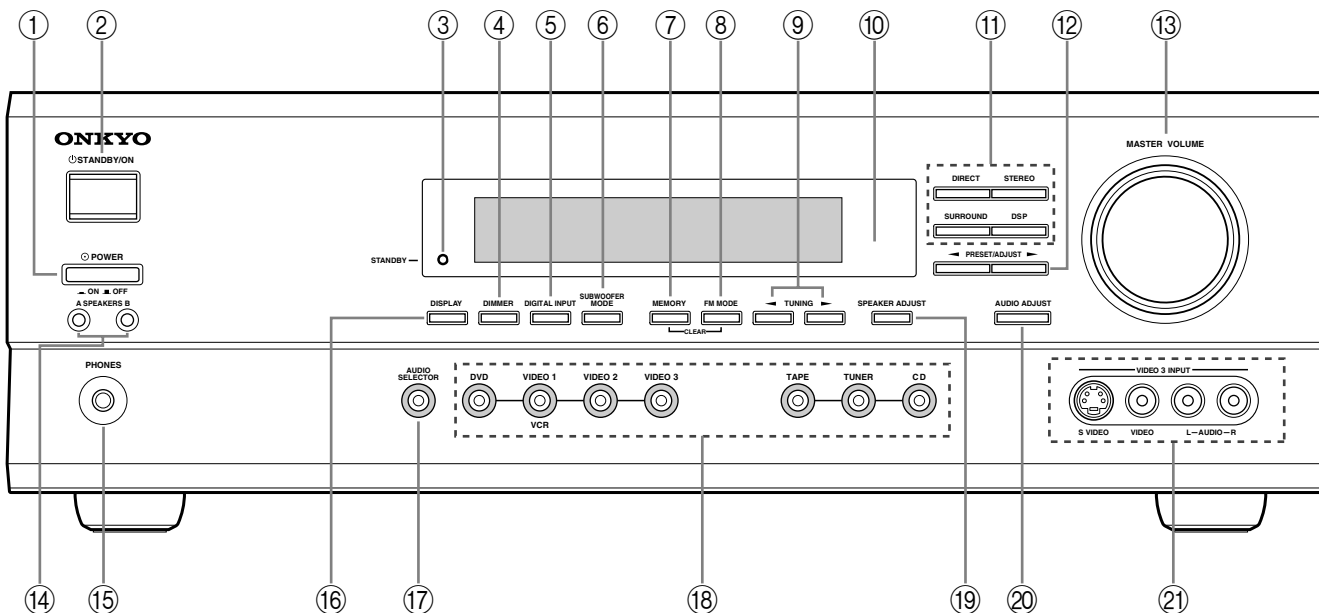

① POWER switch (24)

The North American model doesn't have this switch. This is the main power switch. When set to OFF, the TX-SR501/TX-SR501E is completely shutdown. When set to ON, the TX-SR501/TX-SR501E is in Standby mode and the STANDBY indicator lights up. Don't turn on the power until you've completed, and double checked all connections.

Note:

Turning on the TX-SR501/TX-SR501E may cause a momentary power surge that might interfere with other electrical equipment on the same circuit. If this is a problem, plug the TX-SR501/TX-SR501E into a different branch circuit.

② STANDBY/ON button (24)

This button is used to set the TX-SR501/TX-SR501E to On or Standby. For models with a POWER switch, this button has no effect unless the POWER switch is set to ON.

③ STANDBY indicator (24)

This indicator lights up when the TX-SR501/TX-SR501E is in Standby mode, and it flashes while a signal is being received from the remote controller.

④ DIMMER button (32)

This button is used to adjust the display brightness.

⑤ DIGITAL INPUT button (24)

This button is used to assign the digital inputs.

⑥ SUBWOOFER MODE button (25)

This button is used to select the Subwoofer modes.

Controls & Connectors—Continued

- ⑦ **MEMORY button (30, 31)**
This button is used when storing and deleting radio presets.
- ⑧ **FM MODE button (31)**
This button is used to select the FM radio Stereo and Mono modes. It's also used when deleting radio presets.
- ⑨ **TUNING [◀] [▶] buttons (30)**
These buttons are used to tune into radio stations.
- ⑩ **Remote control sensor (5)**
This sensor receives control signals from the remote controller.
- ⑪ **Listening mode buttons (36)**
These buttons are used to select the listening modes.
- ⑫ **PRESET/ADJUST [◀] [▶] buttons (25, 26, 31, 37)**
This button is used to select radio presets and adjust parameter values.
- ⑬ **MASTER VOLUME control (28, 30)**
This control is used to set the volume of the TX-SR501/TX-SR501E.
- ⑭ **SPEAKER A & B buttons (28, 32)**
These buttons are used to turn speaker sets A and B on and off.
- ⑮ **PHONES jack (33)**
This 1/4-inch phone jack is for connecting a standard pair of stereo headphones for private listening.
- ⑯ **DISPLAY button (32)**
This button is used to display various information about the currently selected source.
- ⑰ **AUDIO SELECTOR button (28, 29)**
This button is used to select the input signal format.
- ⑱ **Input selector buttons (24, 28–30, 39)**
These buttons are used to select the audio and video sources: CD, DVD, TAPE, TUNER, VIDEO 1, VIDEO 2, or VIDEO 3.
- ⑲ **SPEAKER ADJUST button (25, 26)**
This button is used to adjust various speaker-related parameters.
- ⑳ **AUDIO ADJUST button (37)**
This button is used to set the Bass, Treble, Late Night, Cinema Filter, Center Image, Panorama, Dimension, and Center Width functions.
- ㉑ **VIDEO 3 INPUT connectors (15, 39)**
These S-Video, composite video (RCA/phono), and analog audio (RCA/phono) inputs can be used to connect a video camera or games console.

Display

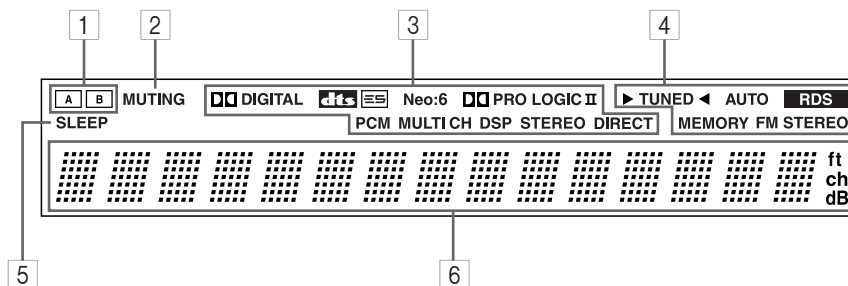

For detailed information, refer to the pages in parenthesis.

- ① **A & B speaker indicators (28, 32)**
Indicator A lights up when speaker set A is on. Indicator B lights up when speaker set B is on.
- ② **MUTING indicator (33)**
This indicator flashes when the TX-SR501/TX-SR501E is muted.
- ③ **Source/listening mode indicators (28, 36)**
These indicators display information about the currently selected source and listening mode.
- ④ **Tuning indicators (30, 31)**
TUNED (30): This indicator lights up when the TX-SR501/TX-SR501E is tuned into a radio station.
- AUTO (30):** This indicator lights up when the Auto Tuning function is on.
- RDS (European model only) (31):** This indicator lights up when the TX-SR501E is tuned into a radio station that supports RDS (Radio Data System).
- MEMORY (31):** This indicator lights up when programming radio presets.
- FM STEREO (31):** This indicator lights up when the TX-SR501/TX-SR501E is tuned into a stereo FM station.
- ⑤ **SLEEP indicator (33)**
This indicator lights up when the Sleep function has been set.
- ⑥ **Message area**
This area of the display shows various information about the currently selected source.

Supplied Accessories

Make sure you have the following accessories:

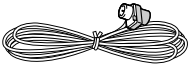
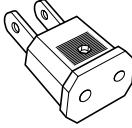
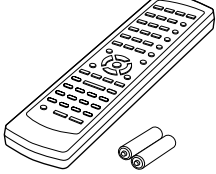
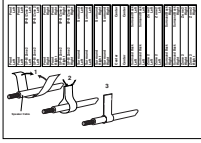
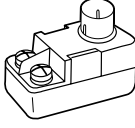
 <p>AM loop antenna</p>	 <p>Indoor FM antenna (connector type varies from country to country)</p>	 <p>Power-plug adapter</p> <p>Only supplied in certain countries. Use this adapter if your AC outlet does not match with the plug on the TX-SR501/TX-SR501E's power cord. (Adapter varies from country to country.)</p>
 <p>Remote controller & two batteries (AA/R6)</p>	 <p>Speaker cable labels</p>	 <p>75/300-ohm antenna adapter</p> <p>Not supplied with North American and European models.</p>

* In catalogs and on packaging, the letter added to the end of the product name indicates the color of the TX-SR501/TX-SR501E. Specifications and operation are the same regardless of color.

Remote Controller—RCVR Mode

RC-518M (North American model)

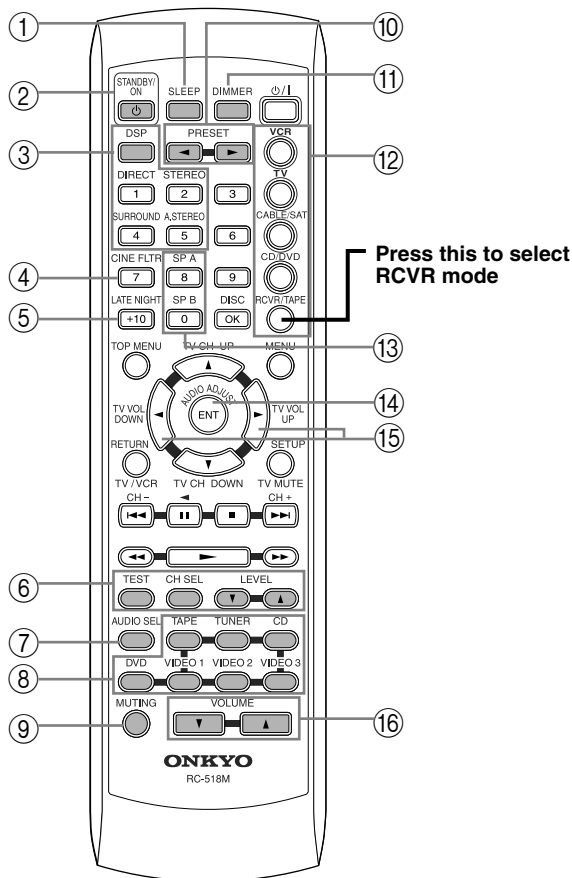

RC-479S (other models)

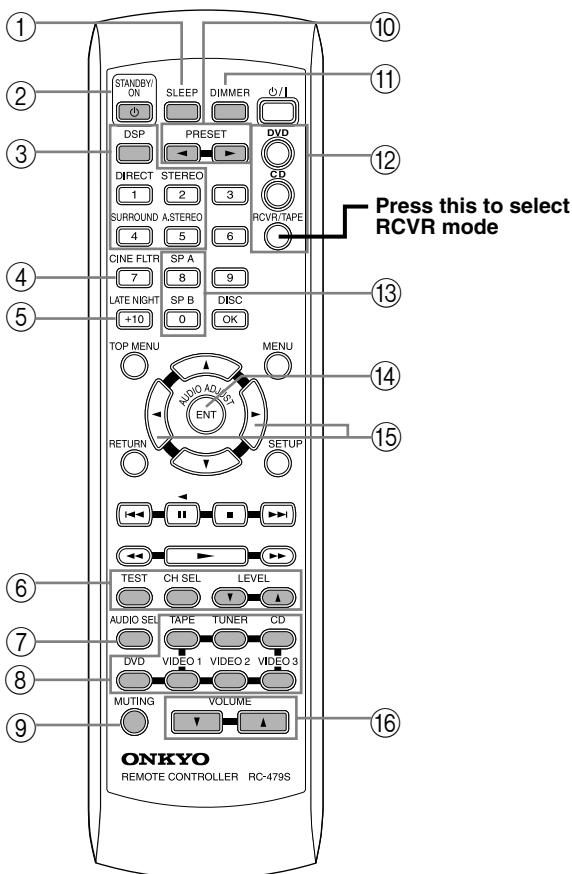

This page describes only those buttons that can be used to control the TX-SR501/TX-SR501E when the remote controller is in RCVR mode (Receiver mode).

To select RCVR mode, press the [RCVR] button.

- ① **SLEEP button (33)**
This button is used to set the Sleep function. This function can be set only with the remote controller.
- ② **STANDBY/ON button (24)**
This button is used to set the TX-SR501/TX-SR501E to On or Standby.
- ③ **Listening mode buttons (36)**
These buttons are used to select the listening modes.
- ④ **CINE FLTR button (37)**
This button is used to set the Cinema Filter function.
- ⑤ **LATE NIGHT button (37)**
This button is used to set the Late Night function.
- ⑥ **TEST, CH SEL & LEVEL [▲] [▼] buttons (27, 29, 33)**
These buttons are used to set the level of each speaker individually. This function can be set only with the remote controller.
- ⑦ **AUDIO SEL button (29)**
This button is used to select analog or digital inputs for the CD, DVD, TAPE, VIDEO 1, VIDEO 2, and VIDEO 3 sources.
- ⑧ **Input selector buttons (28, 30, 39)**
These buttons are used to select the audio and video sources: CD, DVD, TAPE, TUNER, VIDEO 1, VIDEO 2, and VIDEO 3.
- ⑨ **MUTING button (33)**
This button is used to mute the TX-SR501/TX-SR501E. This function can be set only with the remote controller.
- ⑩ **PRESET [◀] [▶] buttons (31)**
These buttons are used to select radio presets.
- ⑪ **DIMMER button (32)**
This button is used to adjust the display brightness.
- ⑫ **Remote Controller Mode buttons (28, 40, 42)**
These buttons are used to select the remote controller modes. To select RCVR mode, press the [RCVR] button.
- ⑬ **SP A & SP B buttons (28, 32)**
These buttons are used to turn on and off speaker sets A and B individually.
- ⑭ **AUDIO ADJUST button (37)**
This button is used to set the Bass, Treble, Late Night, Cinema Filter, Center Image, Panorama, Dimension, and Center Width functions.
- ⑮ **ADJUST [◀] [▶] buttons (37)**
These buttons are used to adjust the functions selected with the AUDIO ADJUST button.
- ⑯ **VOLUME [▲] [▼] buttons (27, 28, 33)**
These buttons are used to set the volume of the TX-SR501/TX-SR501E.

EXPLODED VIEW

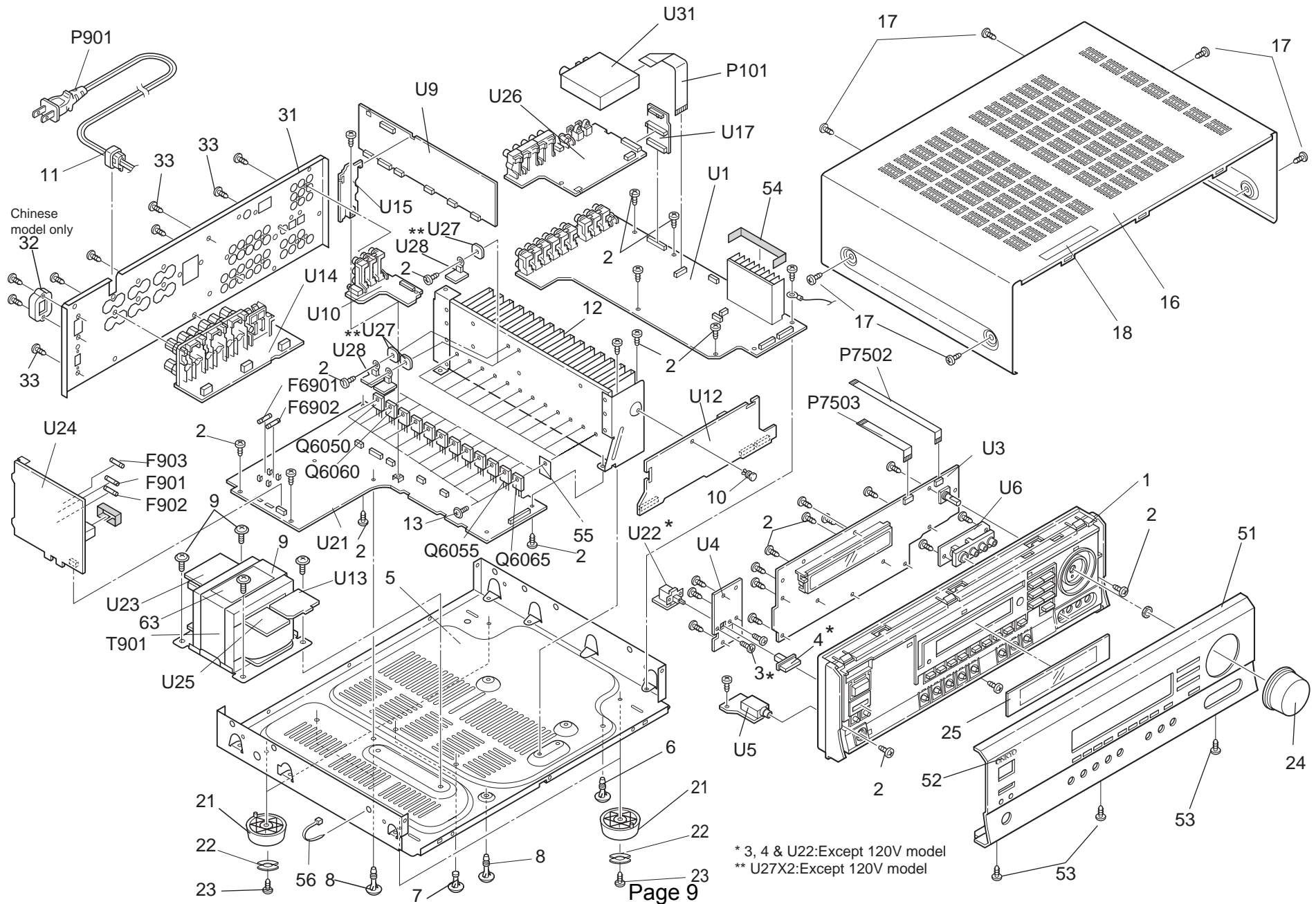

* 3, 4 & U22: Except 120V model
 ** U27X2: Except 120V model

A B C D

BLOCK DIAGRAM

1

2

3

4

5

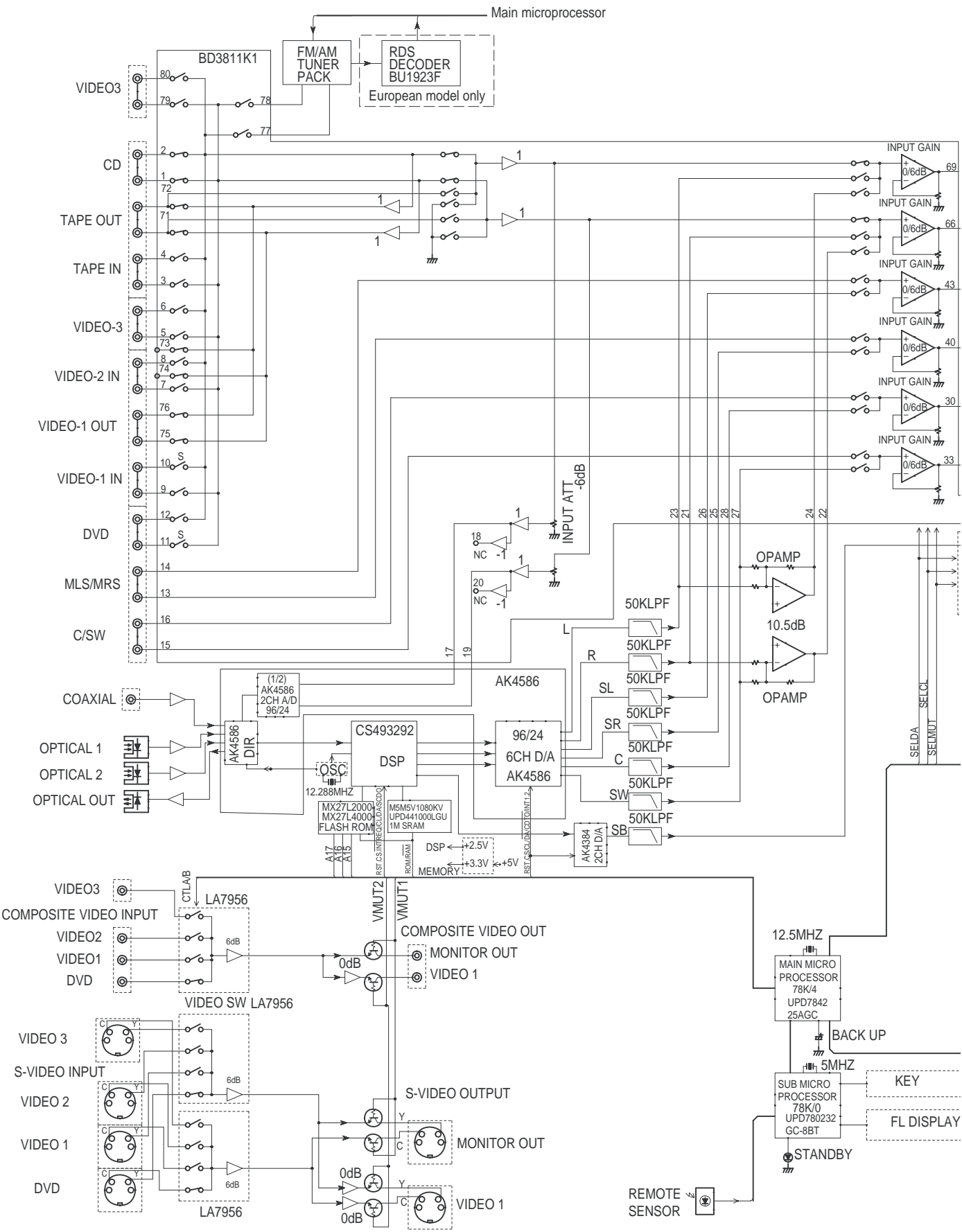

A **B** **C** **D**

BLOCK DIAGRAM

1

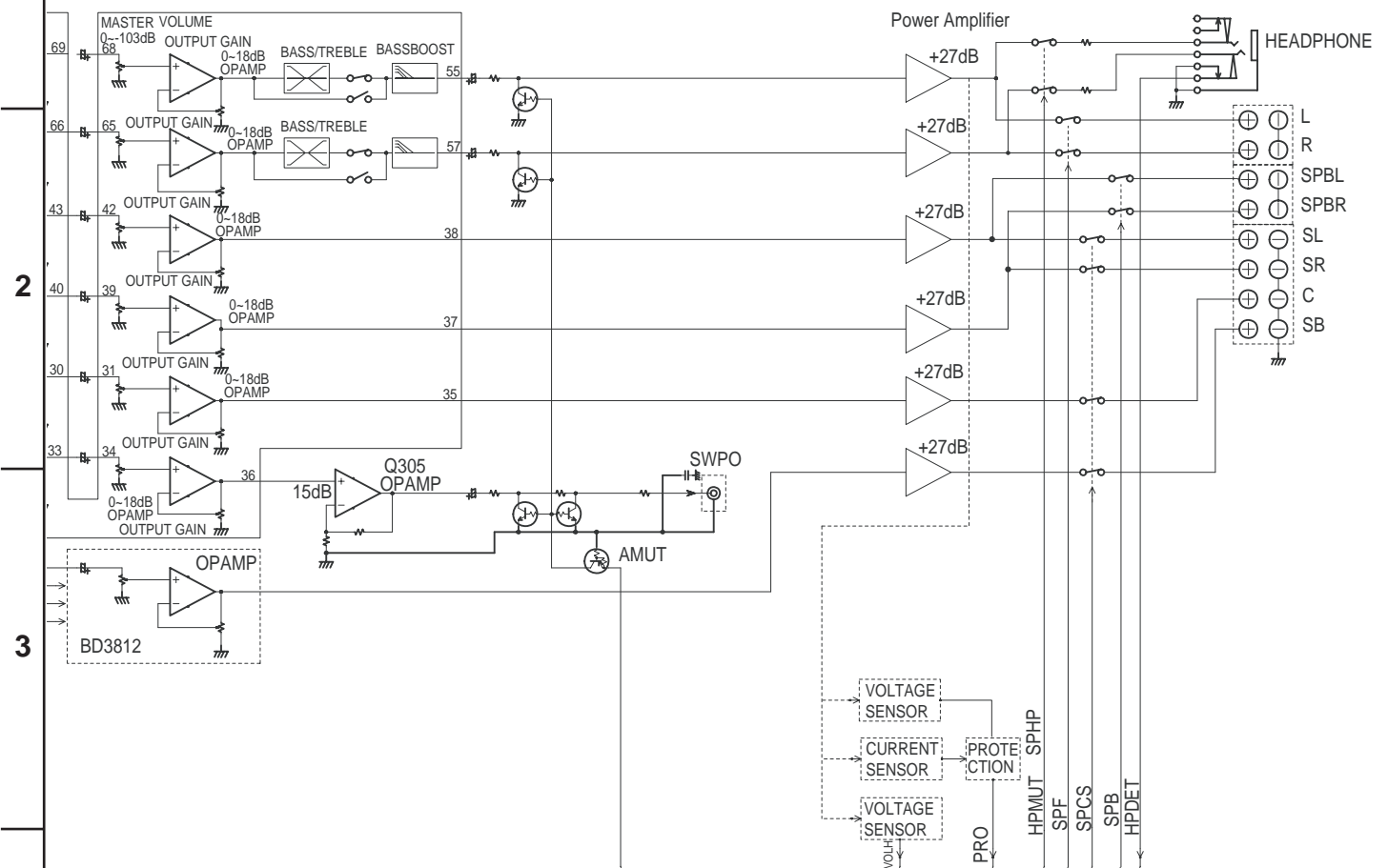

2

3

4

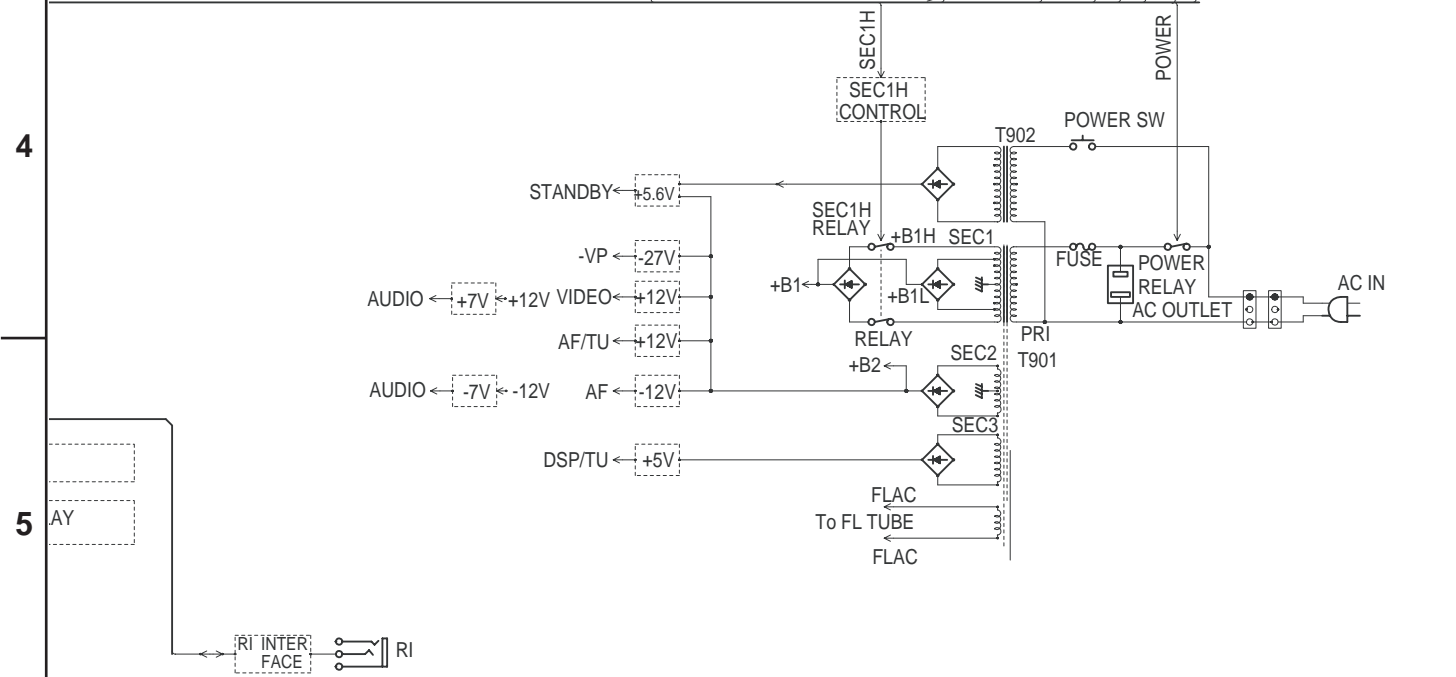

5

SCHEMATIC DIAGRAM 1 Display and video sections

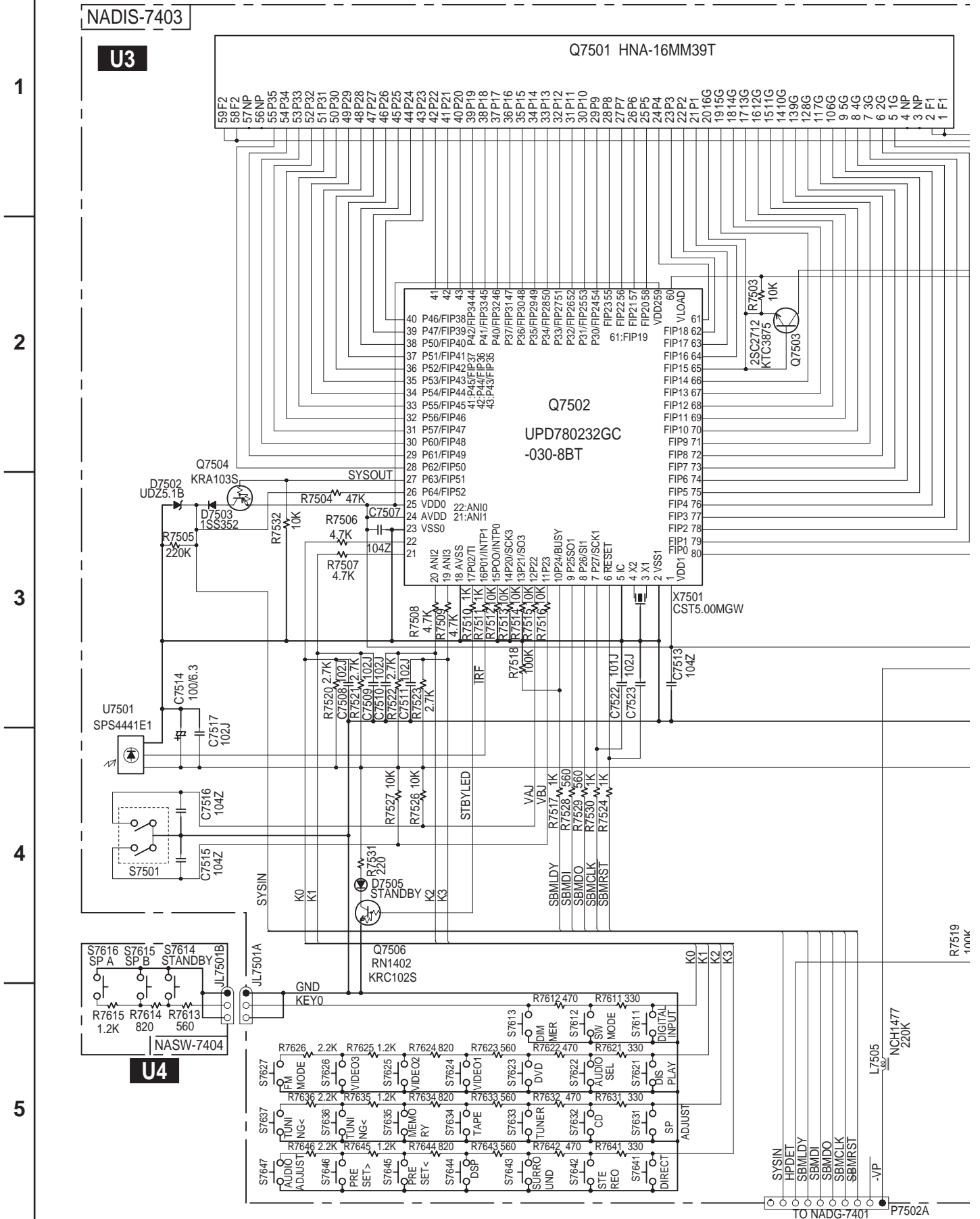

PRINTED CIRCUIT BOARD VIEW 1-2

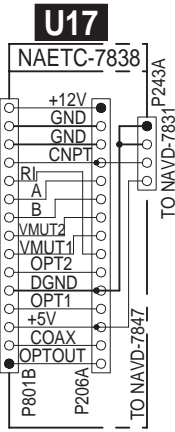
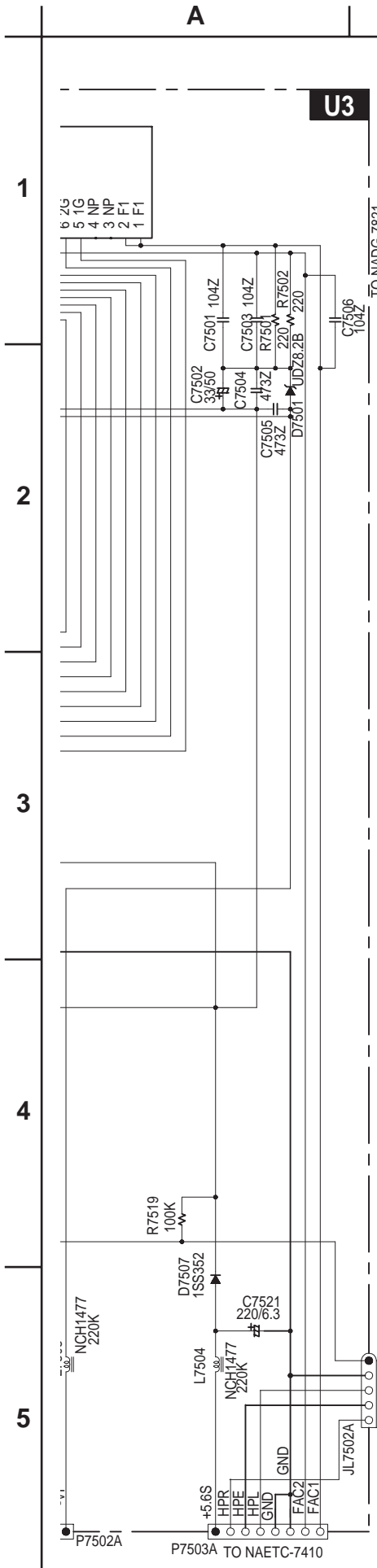

U4 NASW-7404, Standby switch PC board

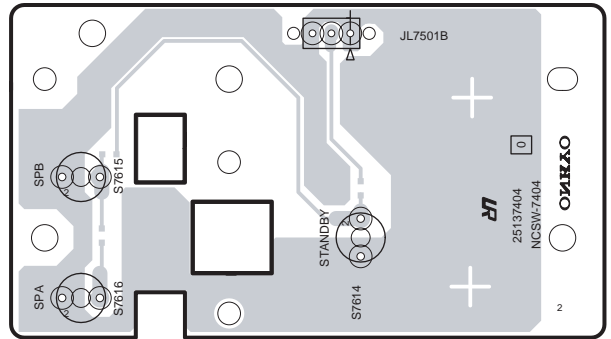

Component side

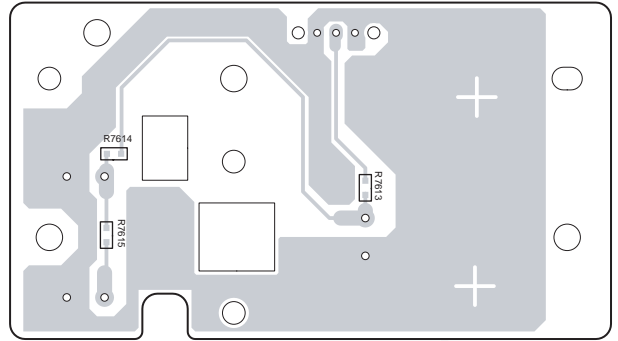

Soldering side

U6 NAETC-7406, Front video PC board

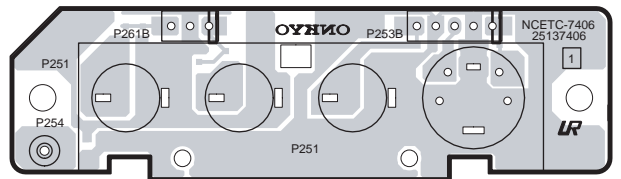

Component side

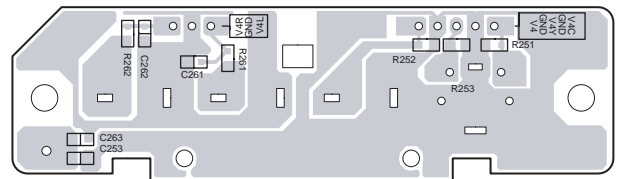

Soldering side

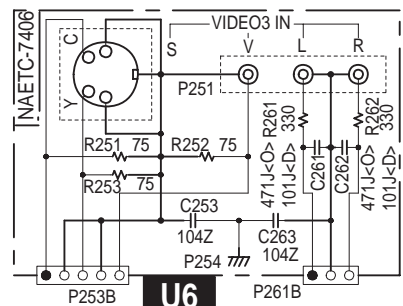
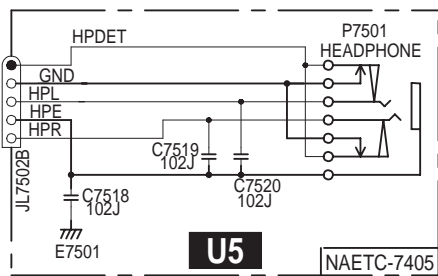

A B C D

SCHEMATIC DIAGRAM 4 Driver amplifier section

1

NAAF-7830

U9

P406/

2

3

4

5

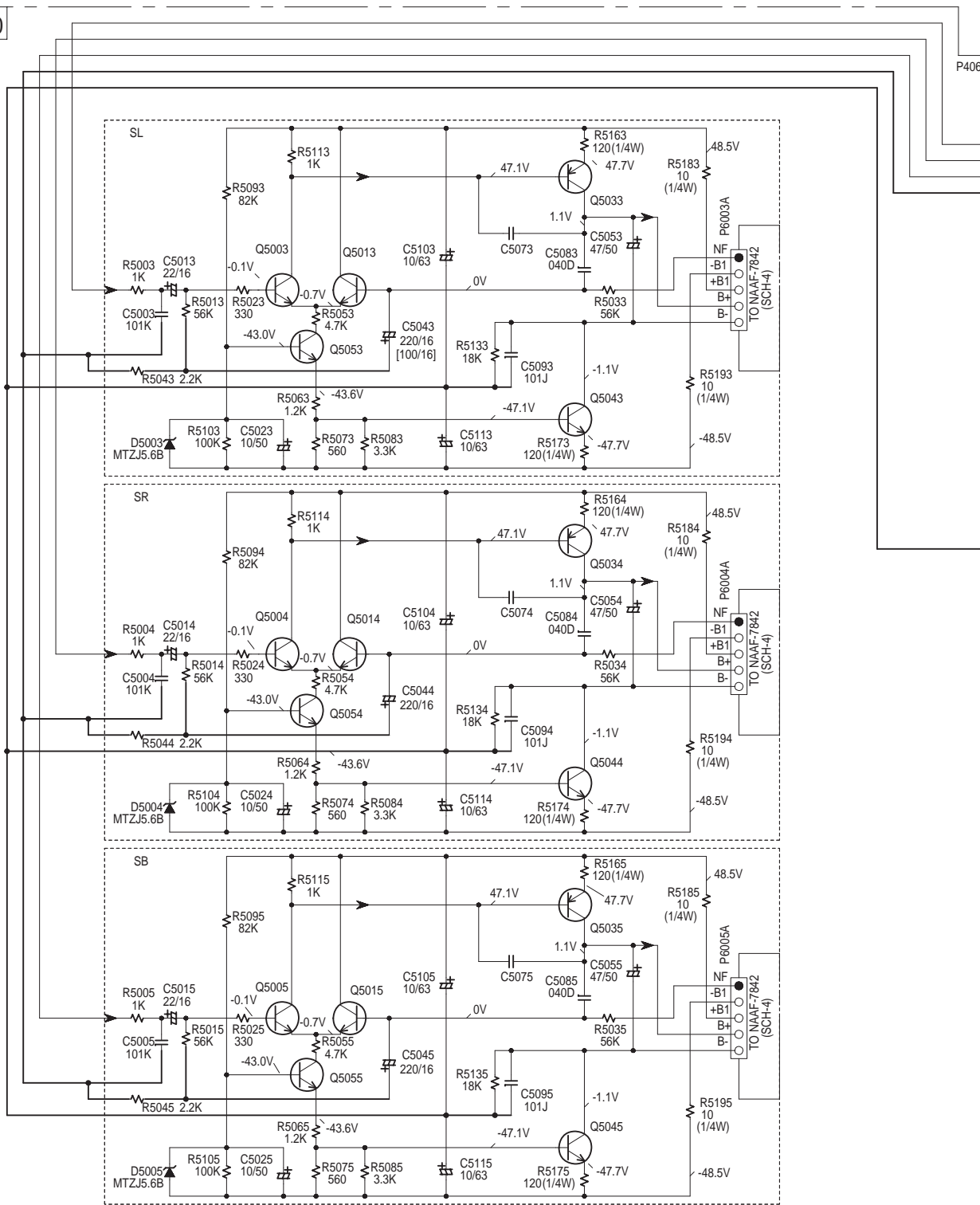

SEMICONDUCTORS

NO.	
Q5000-05,5010-15	KTC3200-BL OR 2SC1775A-E,F OR 2SC1845-E
Q5030-35	KTA1024-Y,O OR 2SA949-Y,O
Q5040-45	KTC3206-Y,O OR 2SC2229-Y,O
Q5050-55	KTC3199-GR,2SC1740S-R,S,2SC2458-GR

A B C D
SCHEMATIC DIAGRAM 4 Driver amplifier section

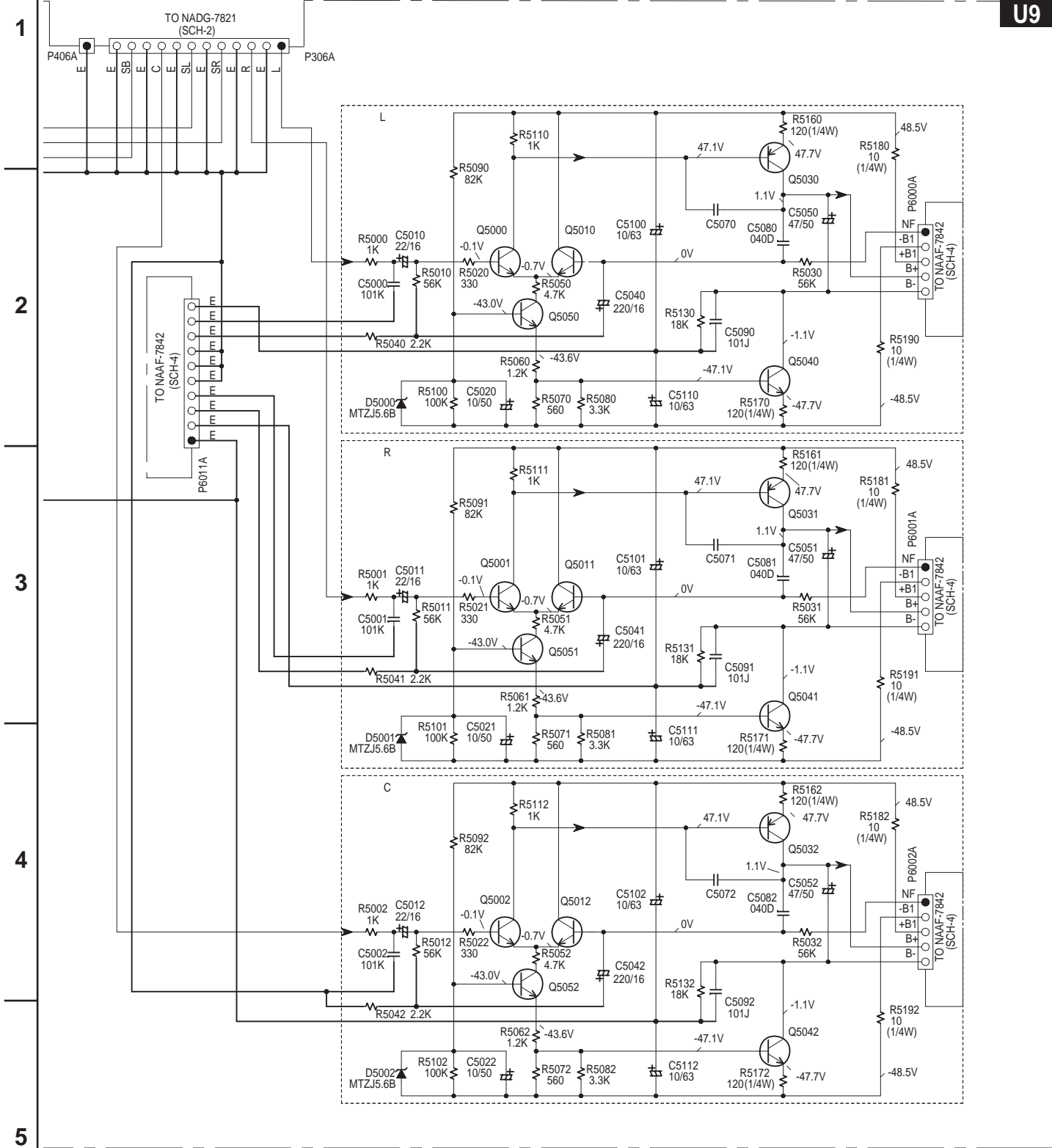

SEMICONDUCTORS

NO.	
Q5000-05,5010-15	KTC3200-BL OR 2SC1775A-E,F OR 2SC1845-E
Q5030-35	KTA1024-Y,O OR 2SA949-Y,O
Q5040-45	KTC3206-Y,O OR 2SC2229-Y,O
Q5050-55	KTC3199-GR,2SC1740S-R,S,2SC2458-GR

A B C D
SCHEMATIC DIAGRAM 2 Digital and main microprocessor sections

1

2

3

4

5

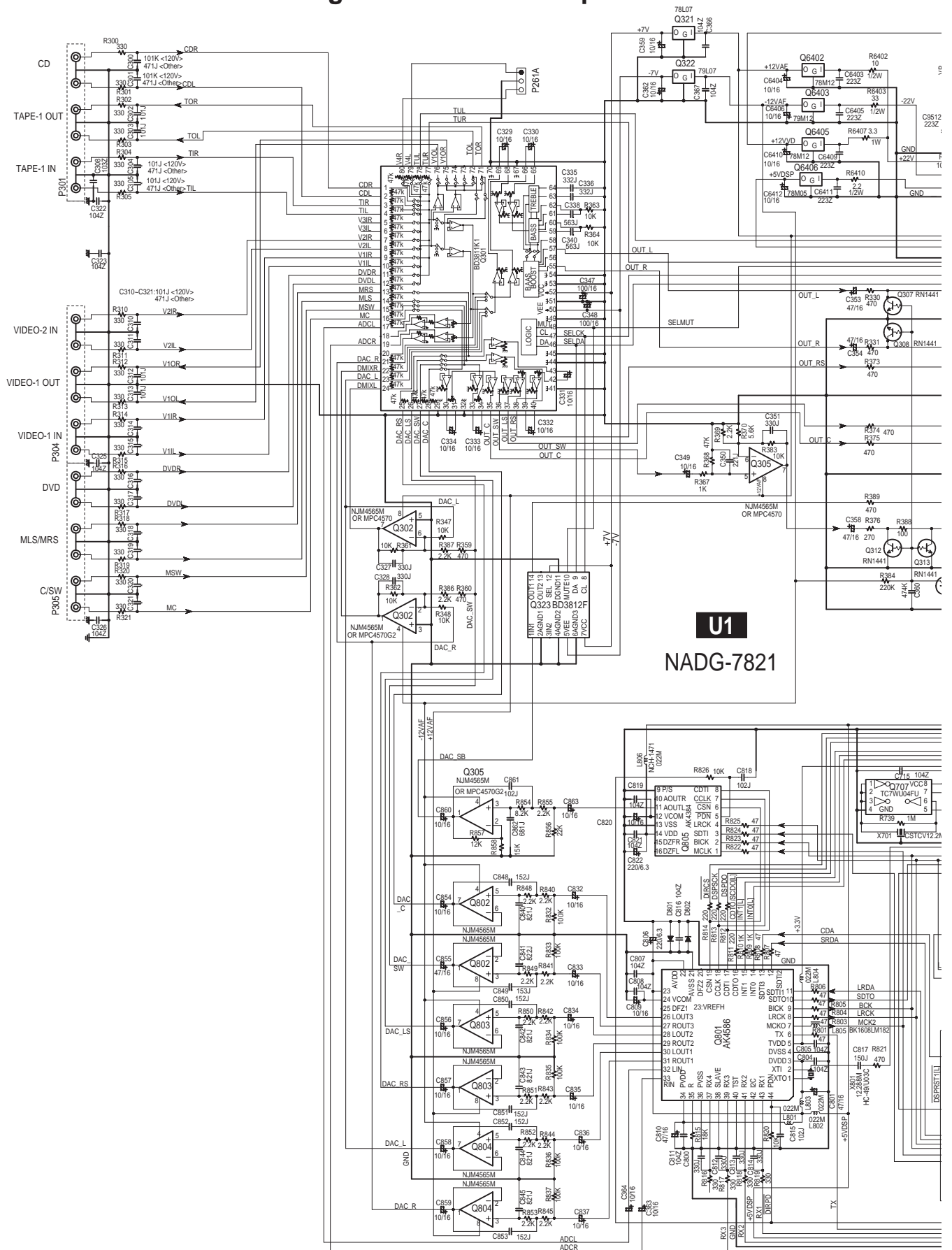

A

B

C

D

SCHEMATIC DIAGRAM 5 Power amplifier section

1

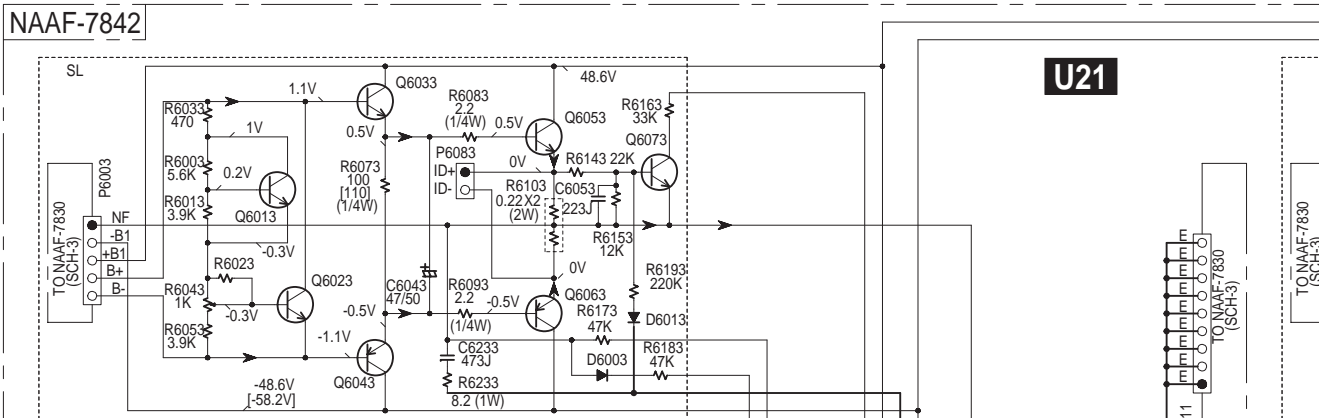

2

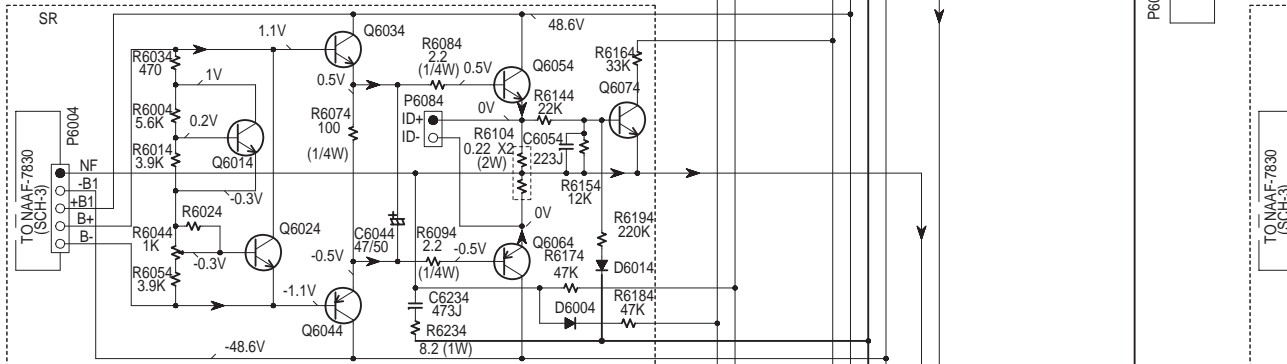

3

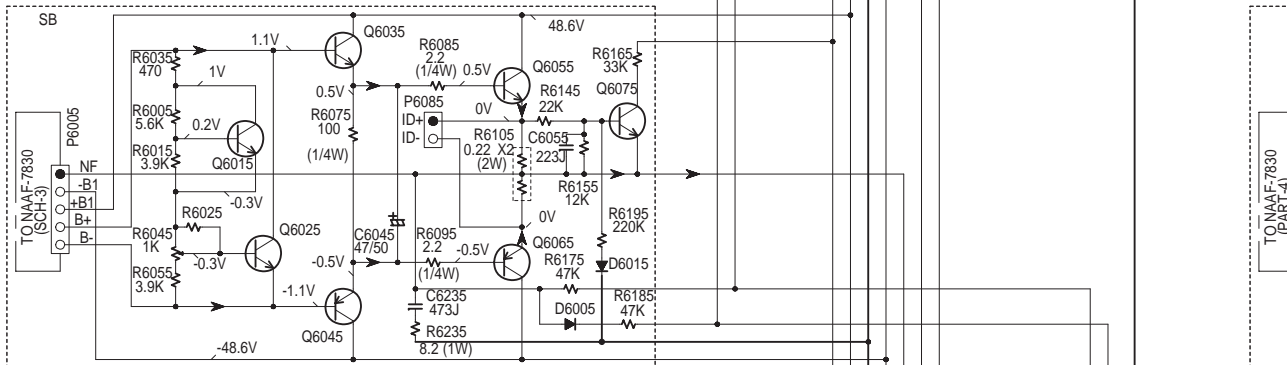

4

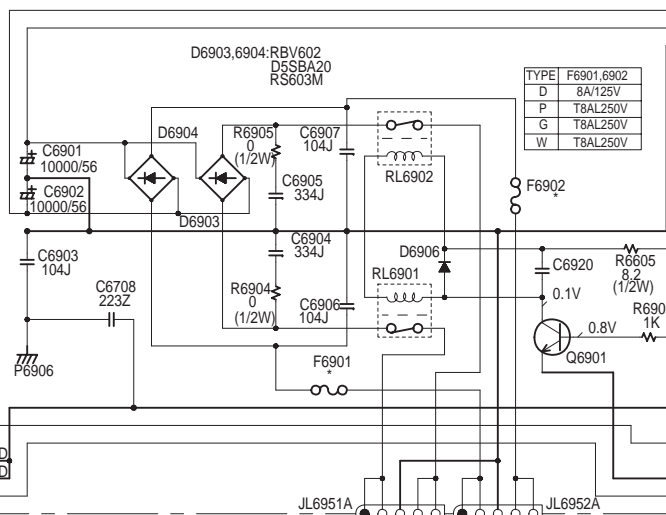

TYPE F6901,6902

D	8A/125V
P	T8AL250V
G	T8AL250V
W	T8AL250V

SEMICONDUCTORS

NO.	
Q6010-6015	2SC1740S-R,S
Q6020-6025	2SC1740S-R,S
Q6030-6035	KTD2061-Y OR 2SC5171
Q6040-6045	KTB1369-Y OR 2SA1930
Q6050-6055	MN100S-Y,P,O OR KTD1047-Y,O
Q6060-6065	MP100P-Y,P,O OR KTB817-Y,O
Q6070-6075	KTC3200-BL,GR OR 2SC1775A-E,F OR 2SC1845-E,F
Q6601-6603,Q6901	KTC3199-GR,2SC1740S-R,S,2SC2458-GR
Q6701,6702	KTC3200-BL,GR OR 2SC1775A-E,F OR 2SC1845-E,F
Q6703	KTA1268-GR,BL OR 2SA992-E,F
Q6303	KTA1267-GR OR 2SA933S-R,S

5

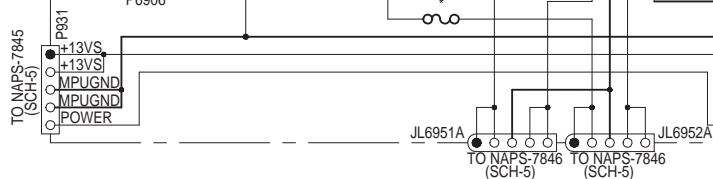

A B C D
SCHEMATIC DIAGRAM 5 Power amplifier section

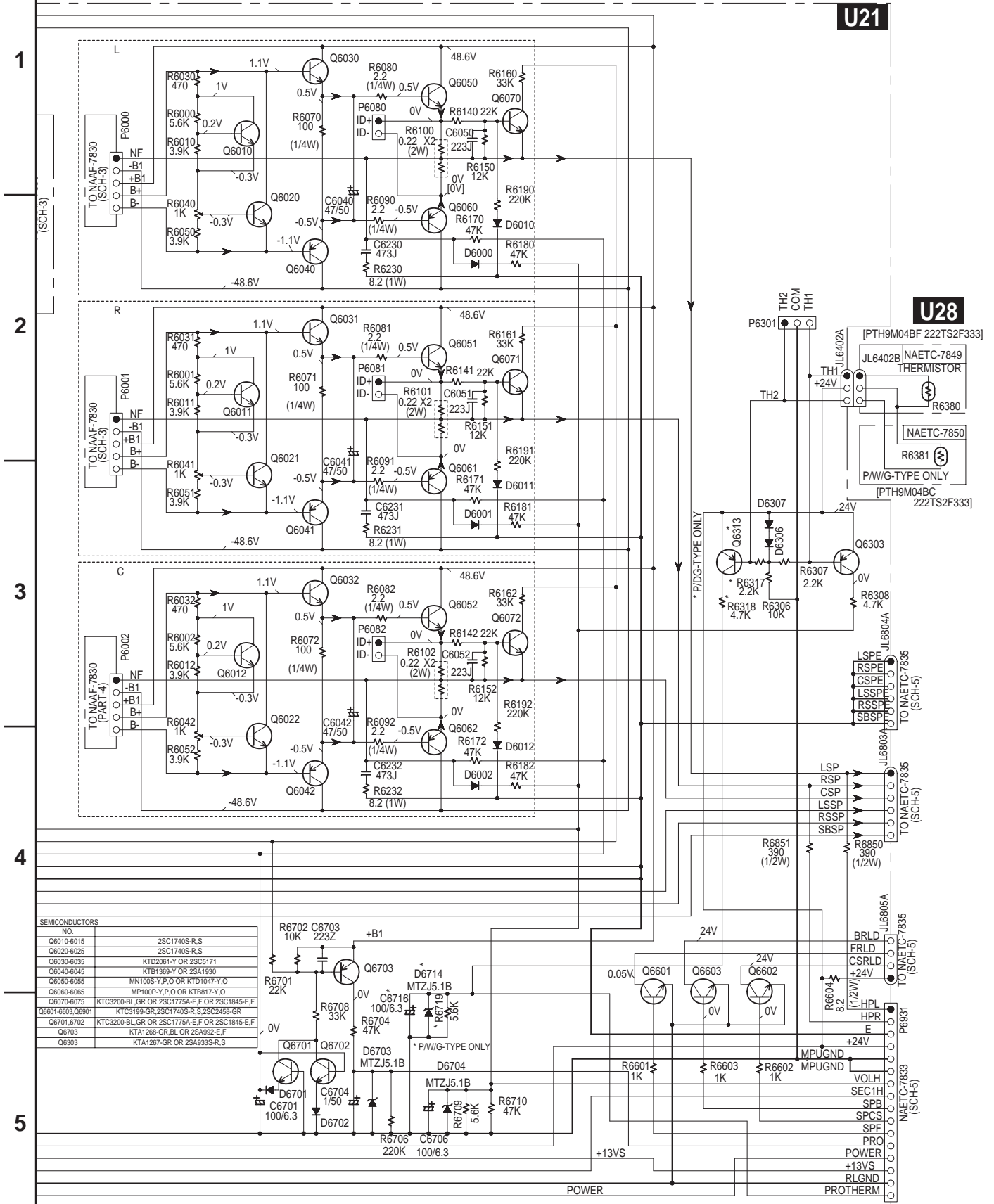

A B C D
SCHEMATIC DIAGRAM 6 Power supply and Speaker terminal sections

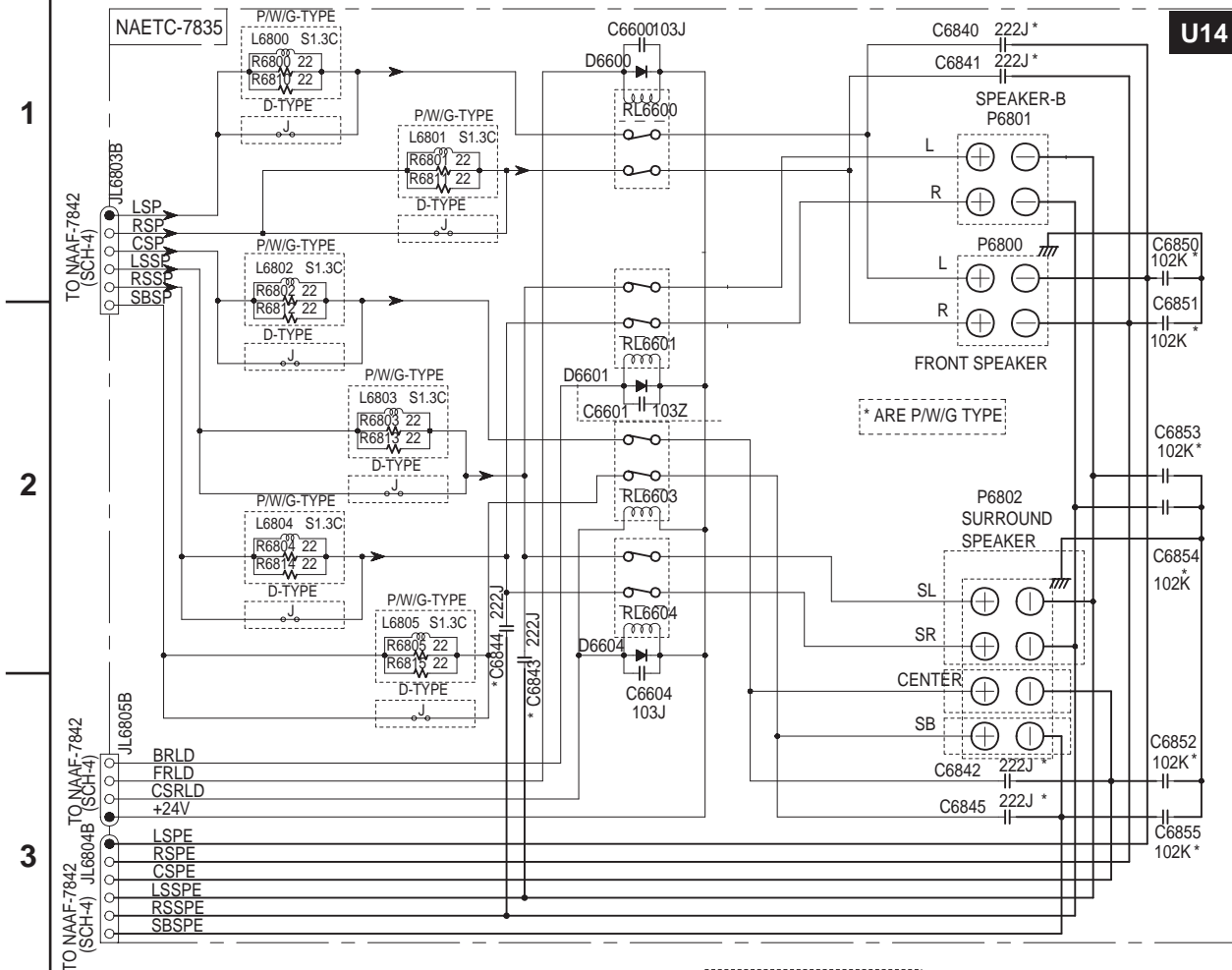

THIS SYMBOL LOCATED NEAR THAT THE FUSE USED IS SLO FOR CONTINUED PROTECT HAZARD, REPLACE WITH SAME RATING REFER TO THE MARK

CE SYMBOLE INDIQUE QUE E LENT, POUR UNE PROTEC QUE DES FUSIBLES DE MEM INDIQUE LA QU LE PRESEN

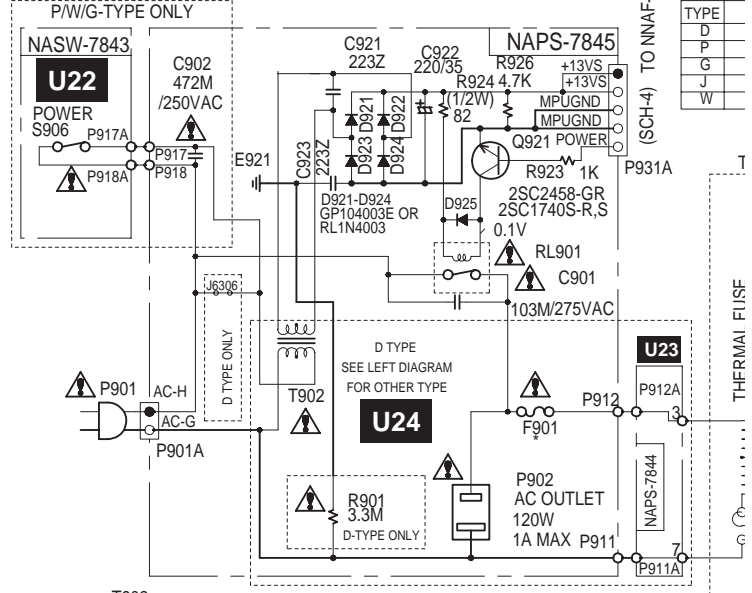
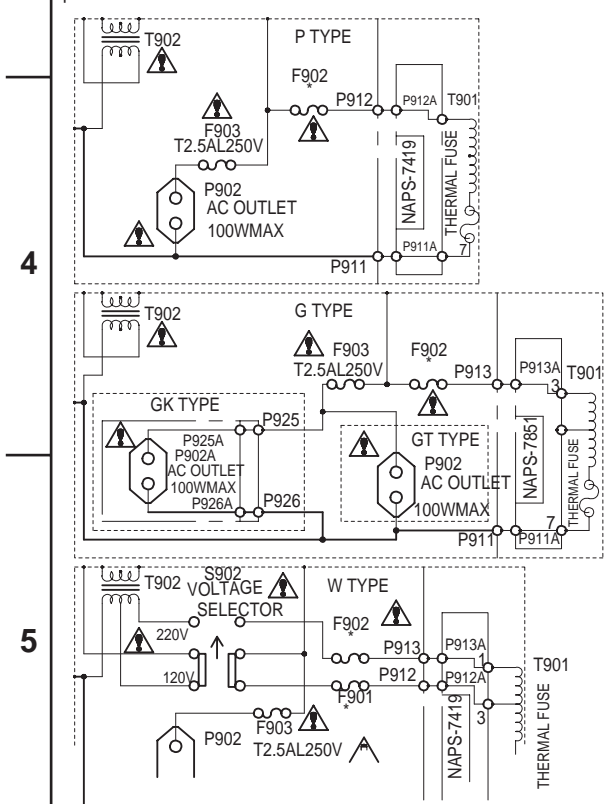

T902	TYPE
D	NPT-1358D
P	NPT-1358P
G	NPT-1358DG
J	NPT-1358J
W	NPT-1358DG

TYPE	F901	F902
D	6.3A/125V	-
P	-	T3.15AL250V
G	-	-
J	8A/125V	-
W	6.3A/125V	T3.15AL250V

T901	TYPE
D	-
P	-
G	-
J	-
W	-

A **B** **C** **D**

SCHEMATIC DIAGRAM 6 Power supply and Speaker terminal sections

1

2

3

4

5

 THIS SYMBOL LOCATED NEAR THE FUSE INDICATES THAT THE FUSE USED IS SLOW OPERATING TYPE FOR CONTINUED PROTECTION AGAINST FIRE HAZARD. REPLACE WITH SAME TYPE FUSE. FOR FUSE RATING REFER TO THE MARKING ADJACENT TO THE SYMBOL.

 CE SYMBOLE INDIQUE QUE LE FUSIBLE UTILISE EST E LENT. POUR UNE PROTECTION PERMANENTE, N'UTILISER QUE DES FUSIBLES DE MEME TYPE. CE DERNIER EST INDIQUE LA QU LE PRESENT SYMBOLE EST APOSE.

CAUTION
FOR CONTINUED PROTECTION AGAINST FIRE HAZARD, REPLACE ONLY WITH FUSE OF SAME TYPE AND RATING INDICATED.

ATTENTION
AFIN D'ASSURER UNE PROTECTION PERMANENTE CONTRE LES RISQUES D'INCENDIE, REMPLACER UNIQUEMENT PAR UN FUSIBLE DE MEME TYPE ET CALIBRATION COMME INDIQUE.

T901	TYPE
	D NPT-1462D
	P NPT-1462P
	G NPT-1462DG
	J NPT-1462J
	W NPT-1462DG

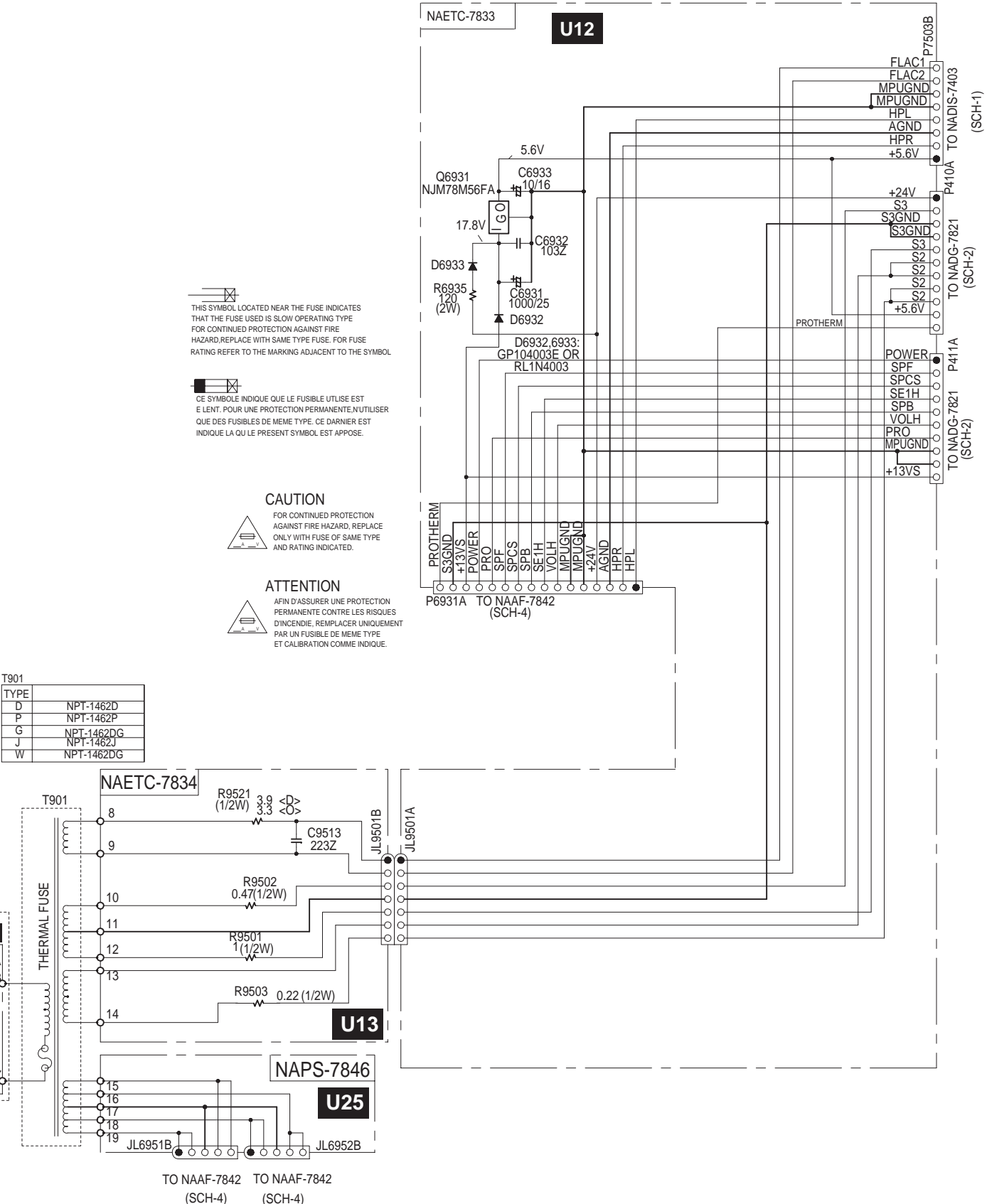

A

B

C

D

SCHEMATIC DIAGRAM 3 Video section

U26

NAVD-7847

1

2

3

4

5

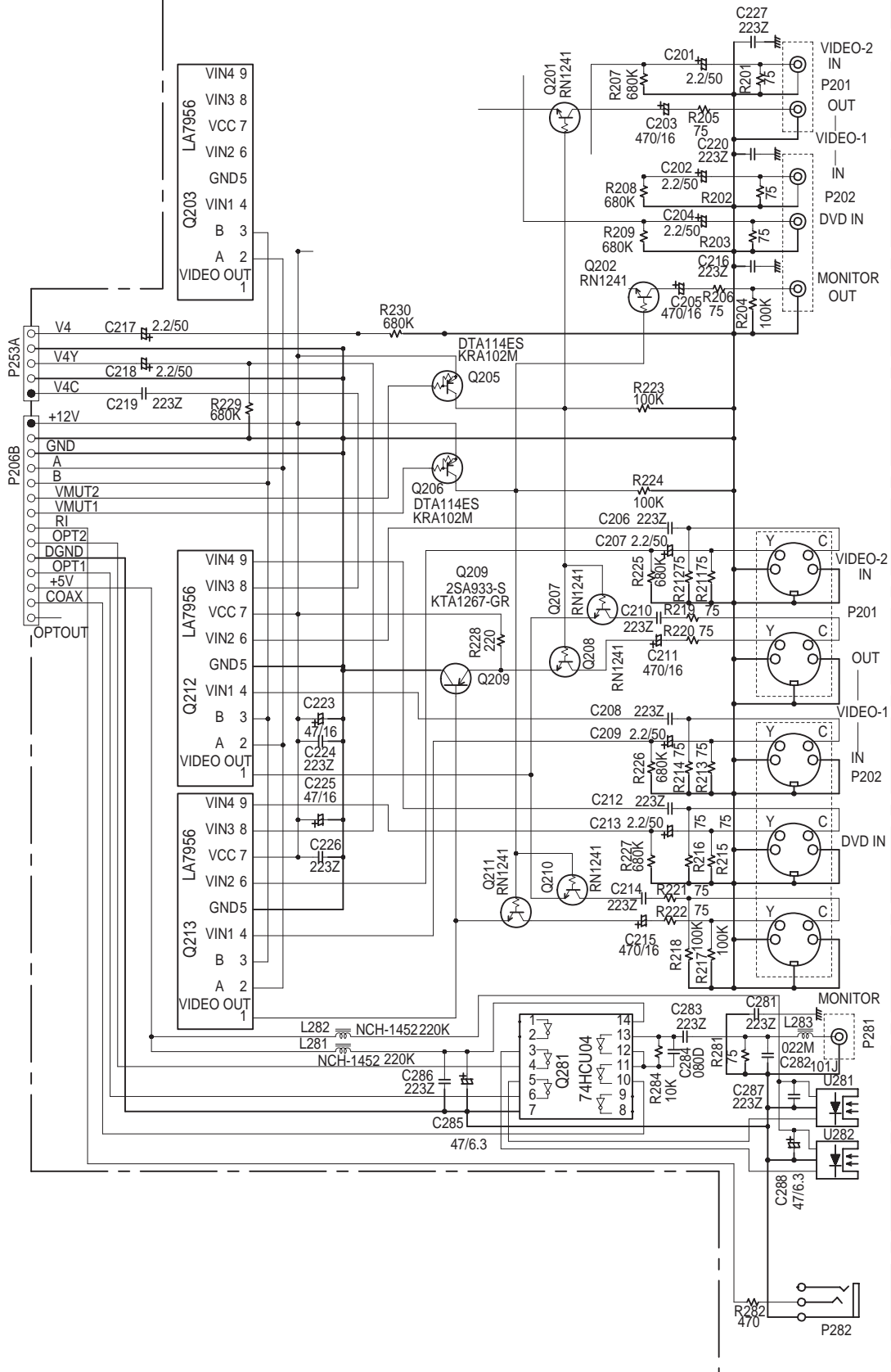

A B C D

SCHEMATIC DIAGRAM 7

Video section

1

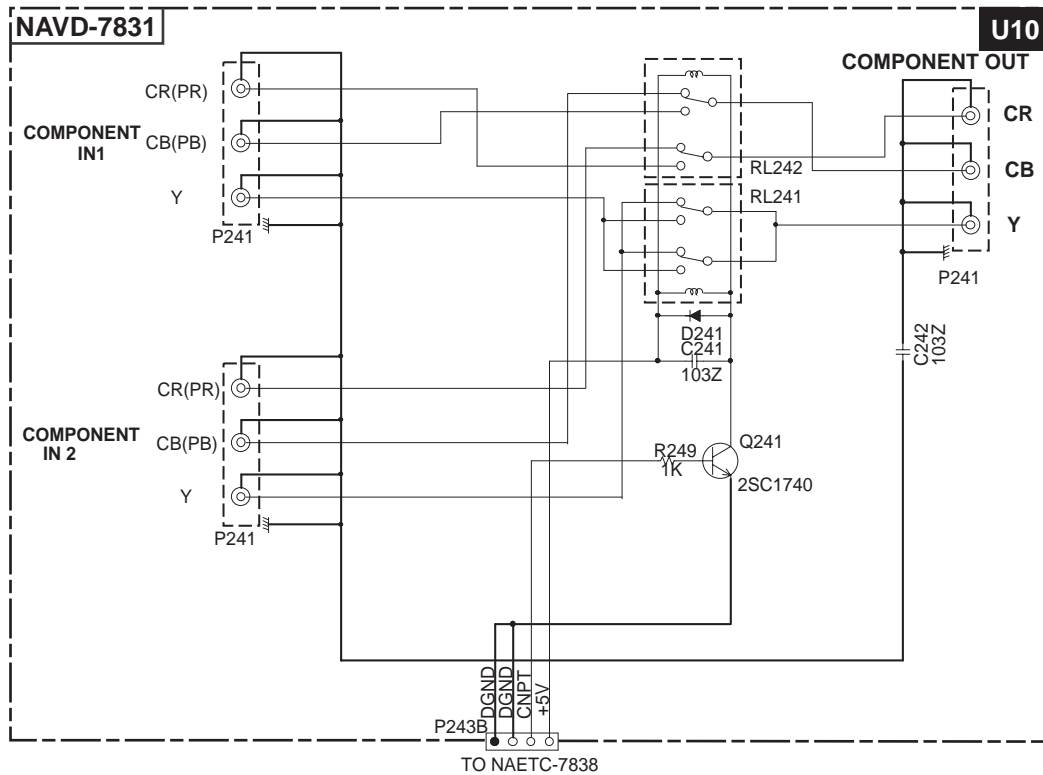

2

3

PRINTED CIRCUIT BOARD VIEW 6

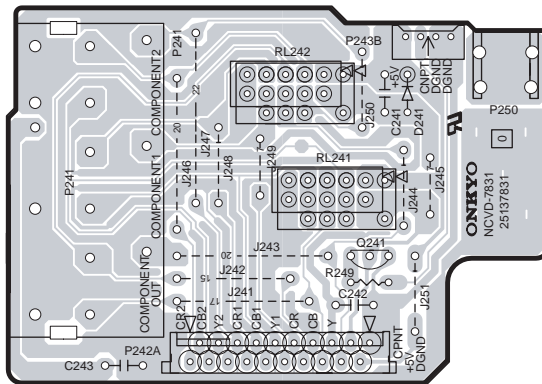

4

5

U10 NAVD-7831, Component video PC board

A

B

C

D

WIRING VIEW

1

U30 Korean model only

NAETC-7835, Speaker terminal PC board ass'y

NAETC-7851, AC outlet terminal PC board ass'y

U14

U24 NAPS-7845, Primary circuit PC board ass'y

2

U22 NASW-7843, Power switch PC board ass'y

NAETC-7834, Secondary PC board ass'y

U13

NAAF-7842, Power amplifier PC board ass'y

3

T901 POWER TRANSFORMER NPT-1462 NPT-1465D

U23 NAPS-7844, Transformer terminal PC board ass'y

U25 NAPS-7846, Secondary terminal PC board ass'y

4

NAETC-7833 circuit PC board

5

U5 NAETC-7405, Headphone terminal PC board ass'y

U4 NASW-7404, Standby switch PC board ass'y

NADIS-7403, Display circuit

U3

WIRING VIEW

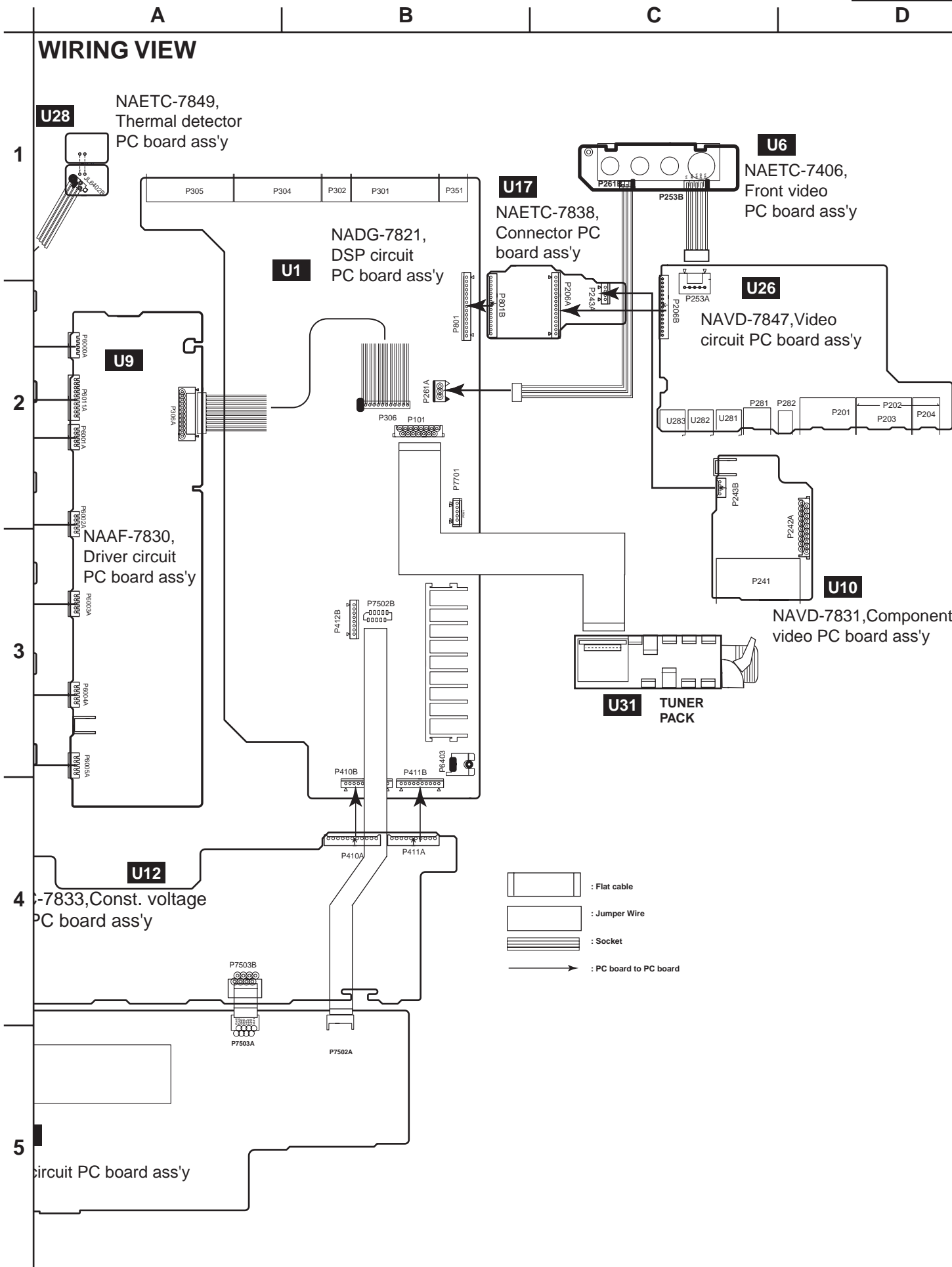

A

B

C

D

BLOCK DIAGRAM

U3 NADIS-7403, Display circuit PC board

1

2

3

Component side

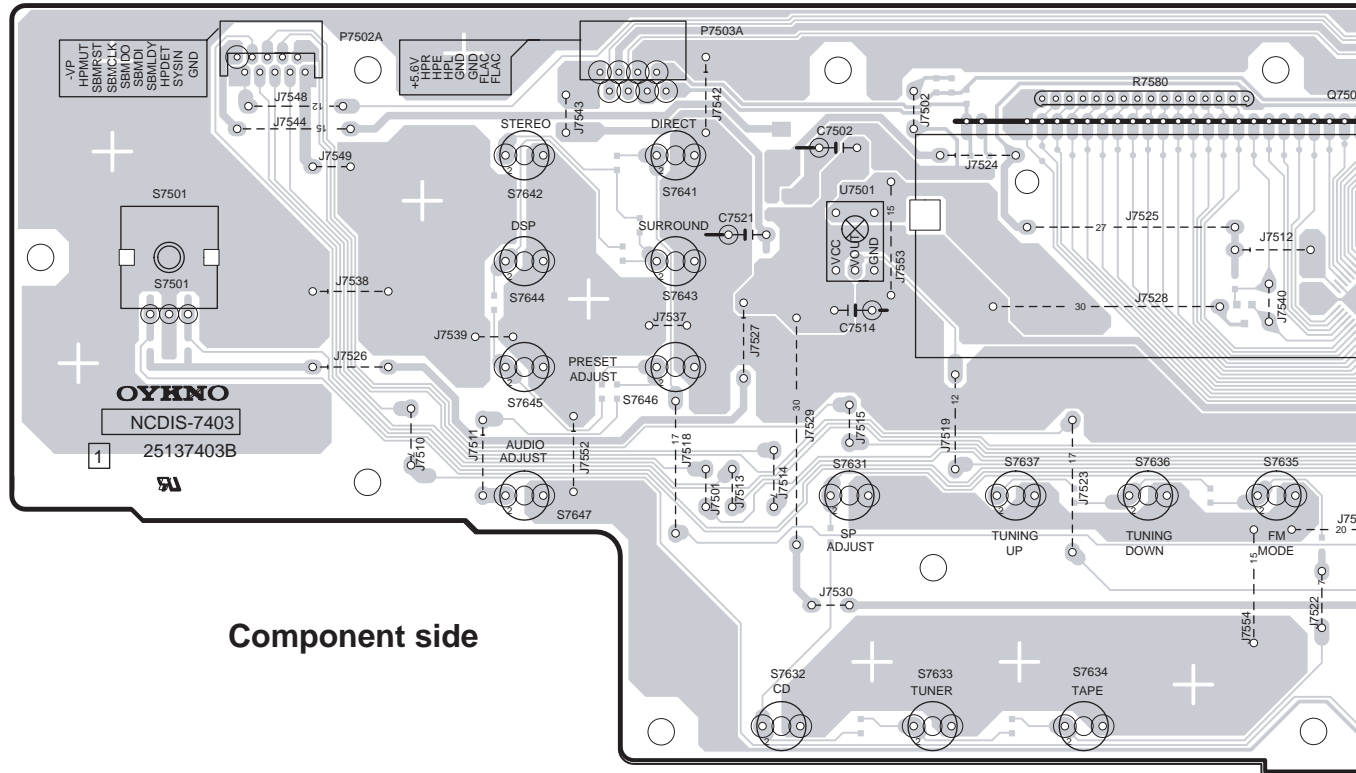

4

Soldering side

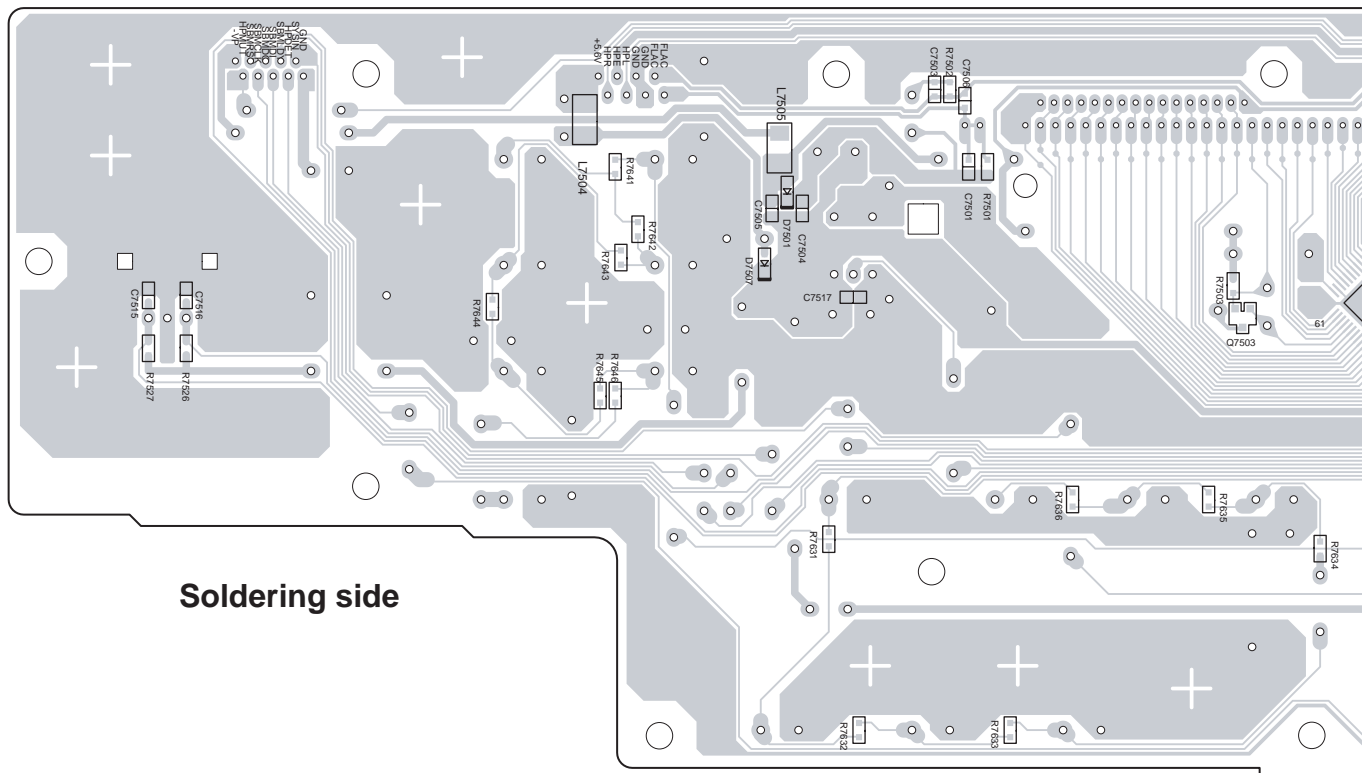

5

A

B

C

D

PRINTED CIRCUIT BOARD VIEW FROM SOLDERING SIDE 1

U5 NAETC-7405,Headphone terminal PC board

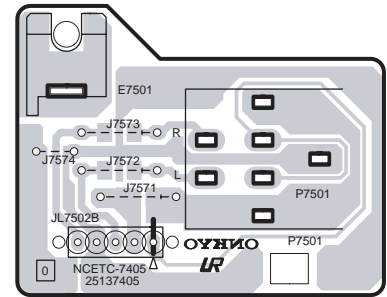

Component side

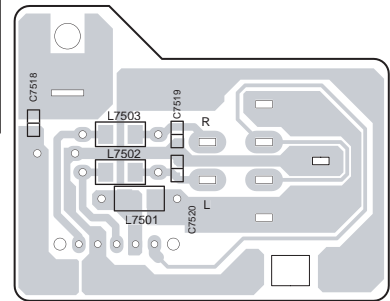

Soldering side

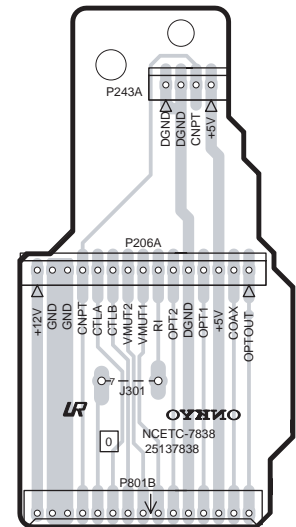

U17 NAETC-7838,Connector PC board ass'y

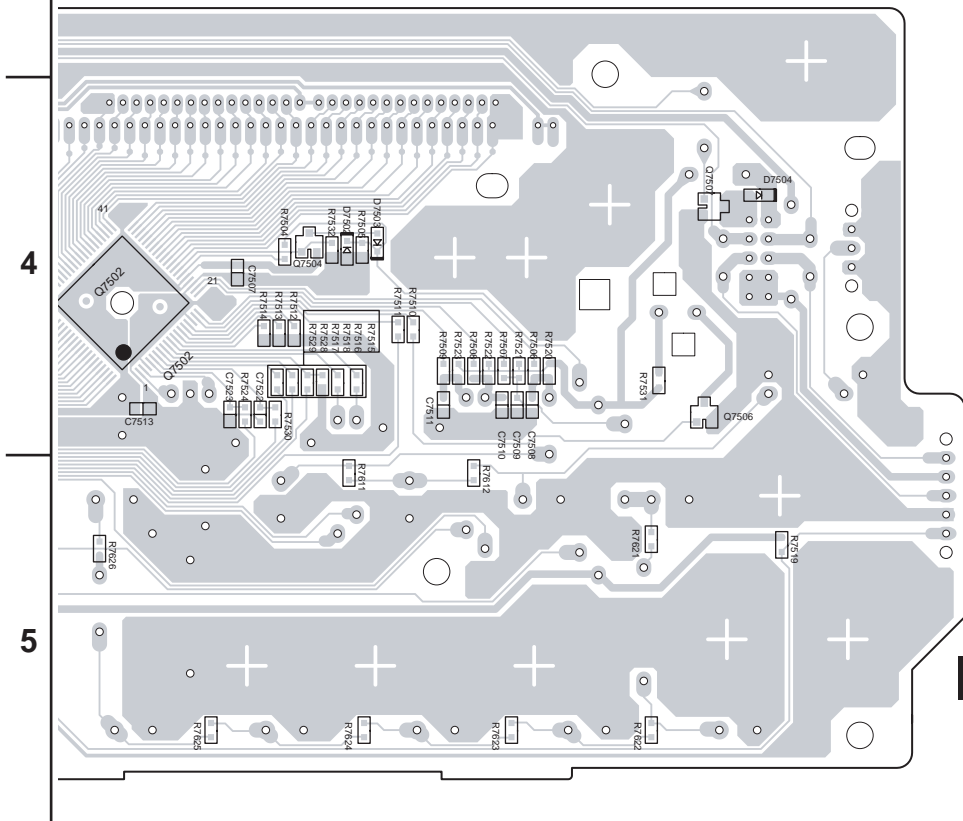
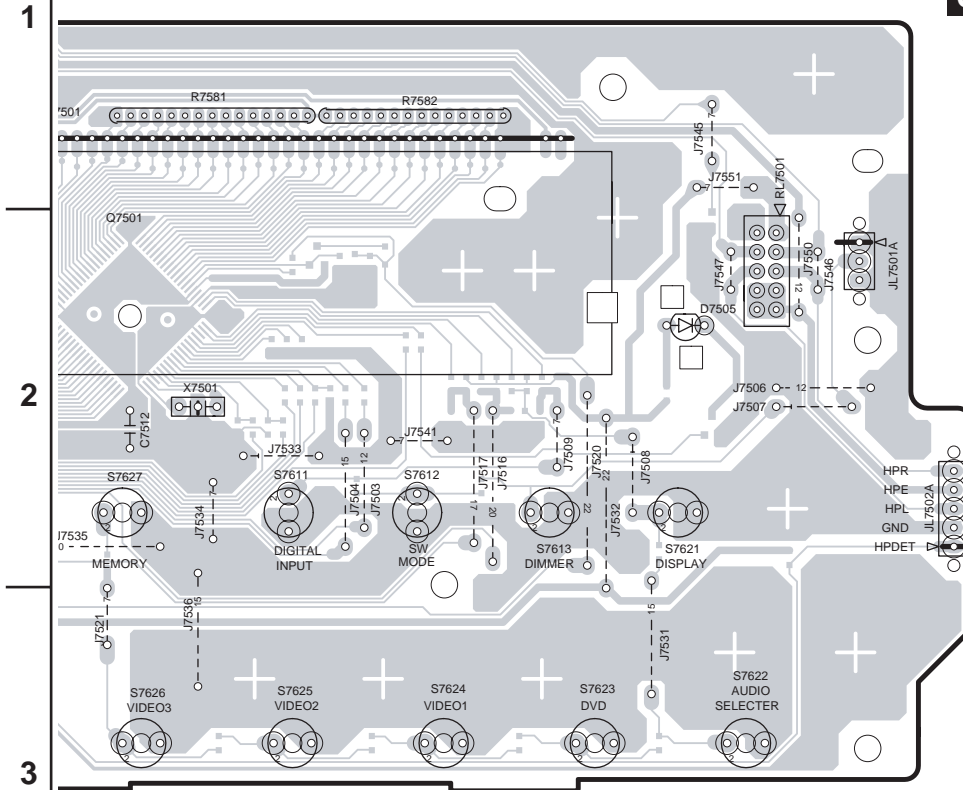

A B C D

PRINTED CIRCUIT BOARD VIEW 2

1
2
3
4
5

U1 NADG-7821, DSP circuit PC board

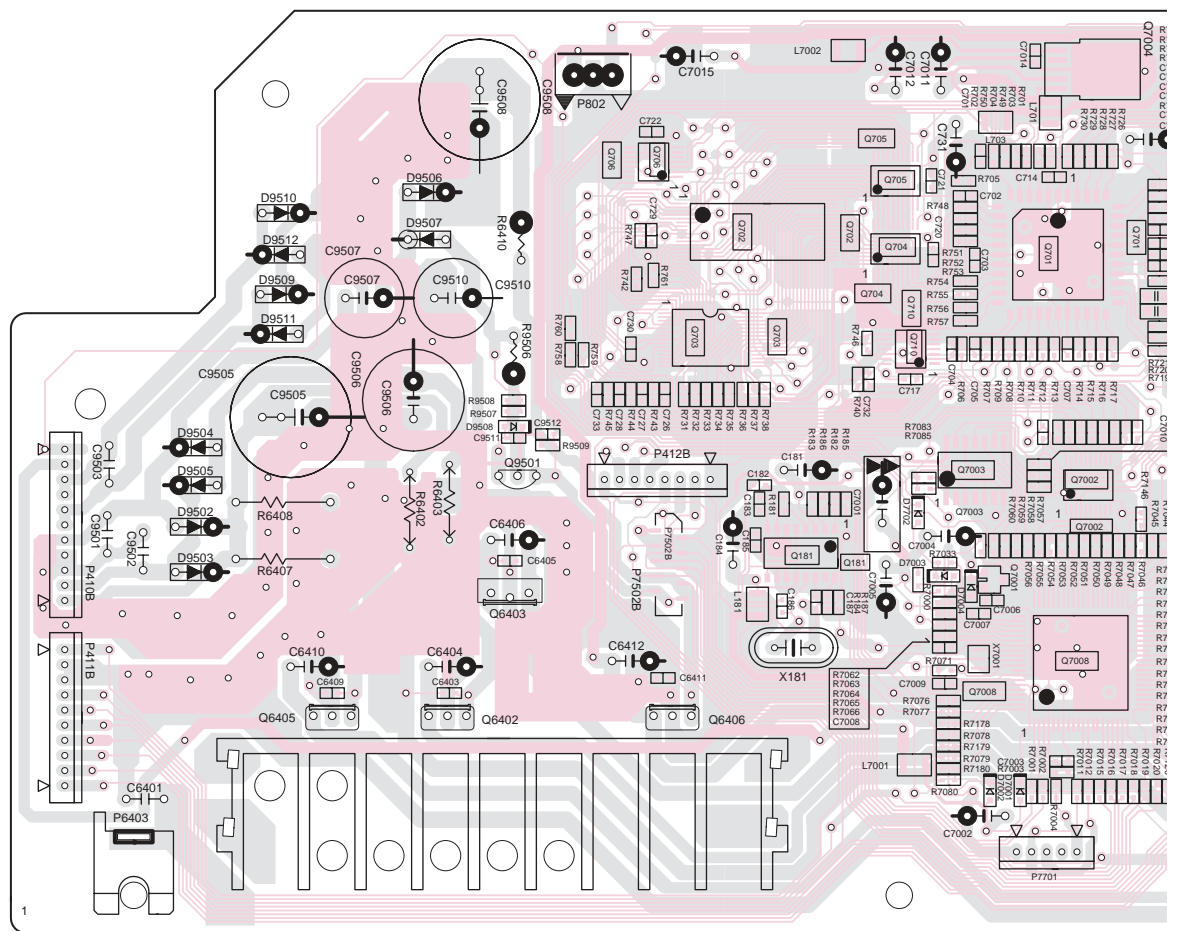

A B C D

PRINTED CIRCUIT BOARD VIEW 2

1
2
3
4
5

U1 NADG-7821, DSP circuit PC board

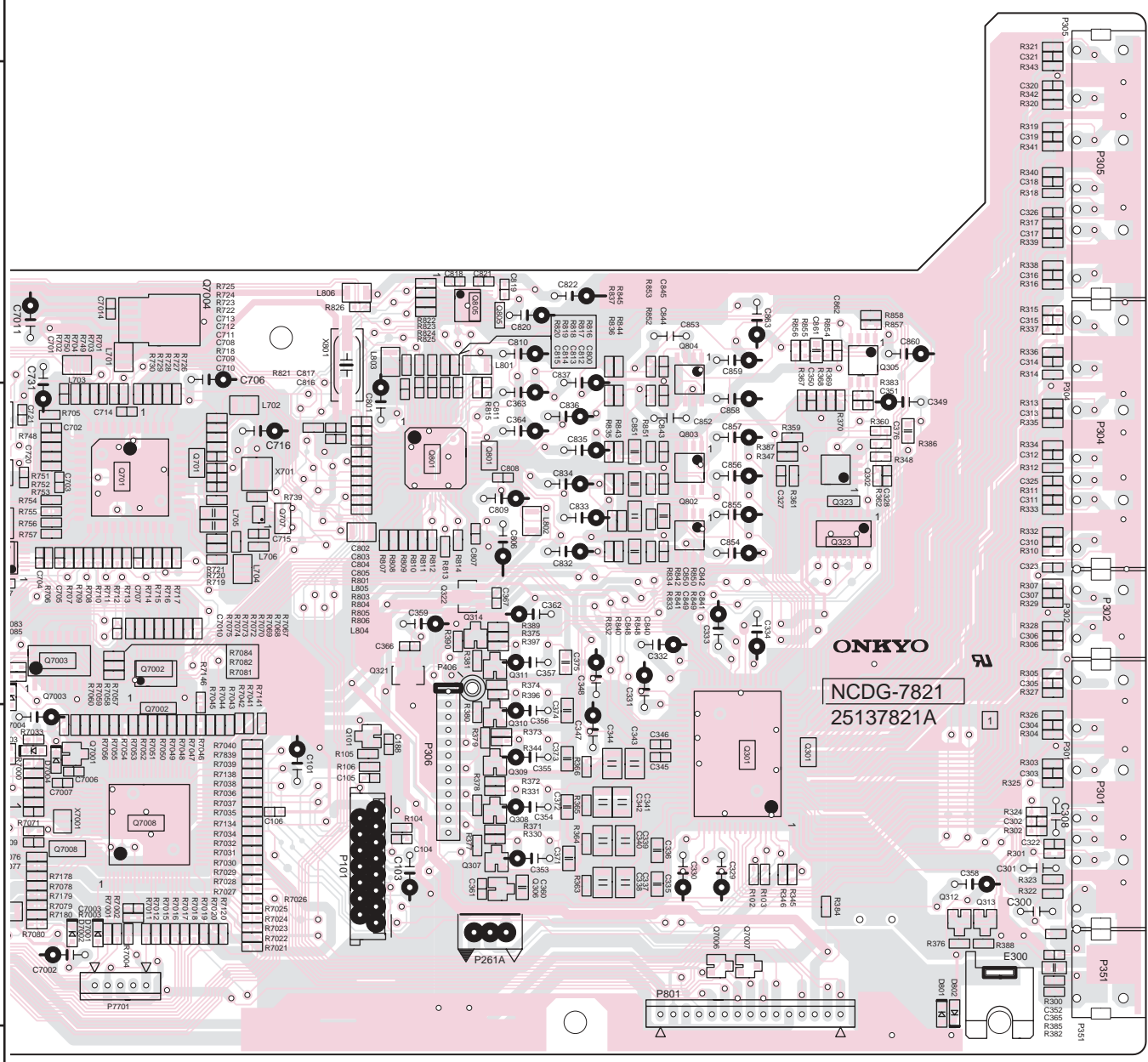

A

B

C

D

PRINTED CIRCUIT BOARD VIEW 4

1

2

3

4

5

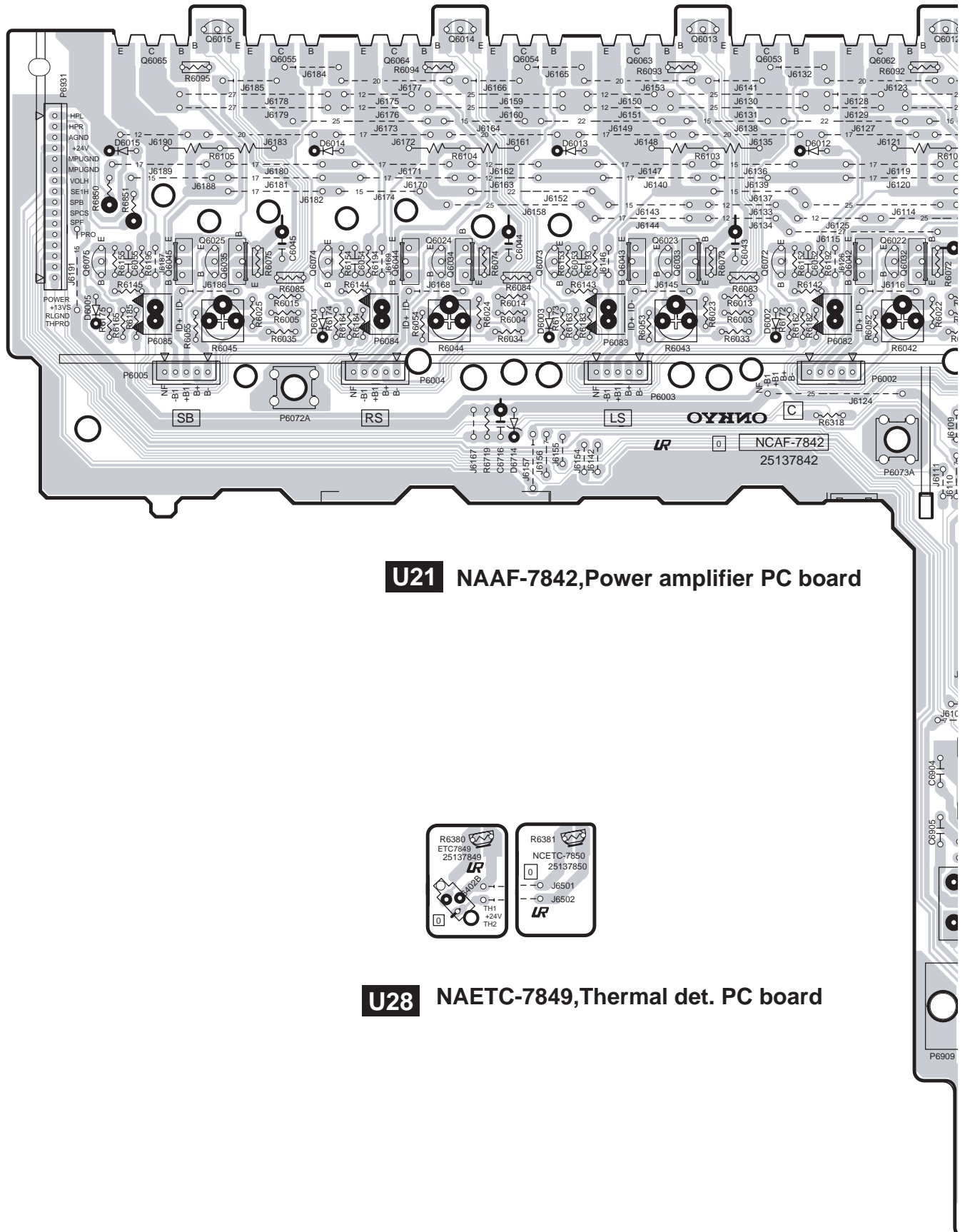

U21 NAAF-7842, Power amplifier PC board

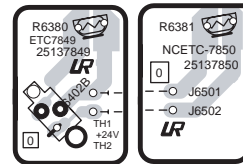

U28 NAETC-7849, Thermal det. PC board

A

B

C

D

PRINTED CIRCUIT BOARD VIEW 4

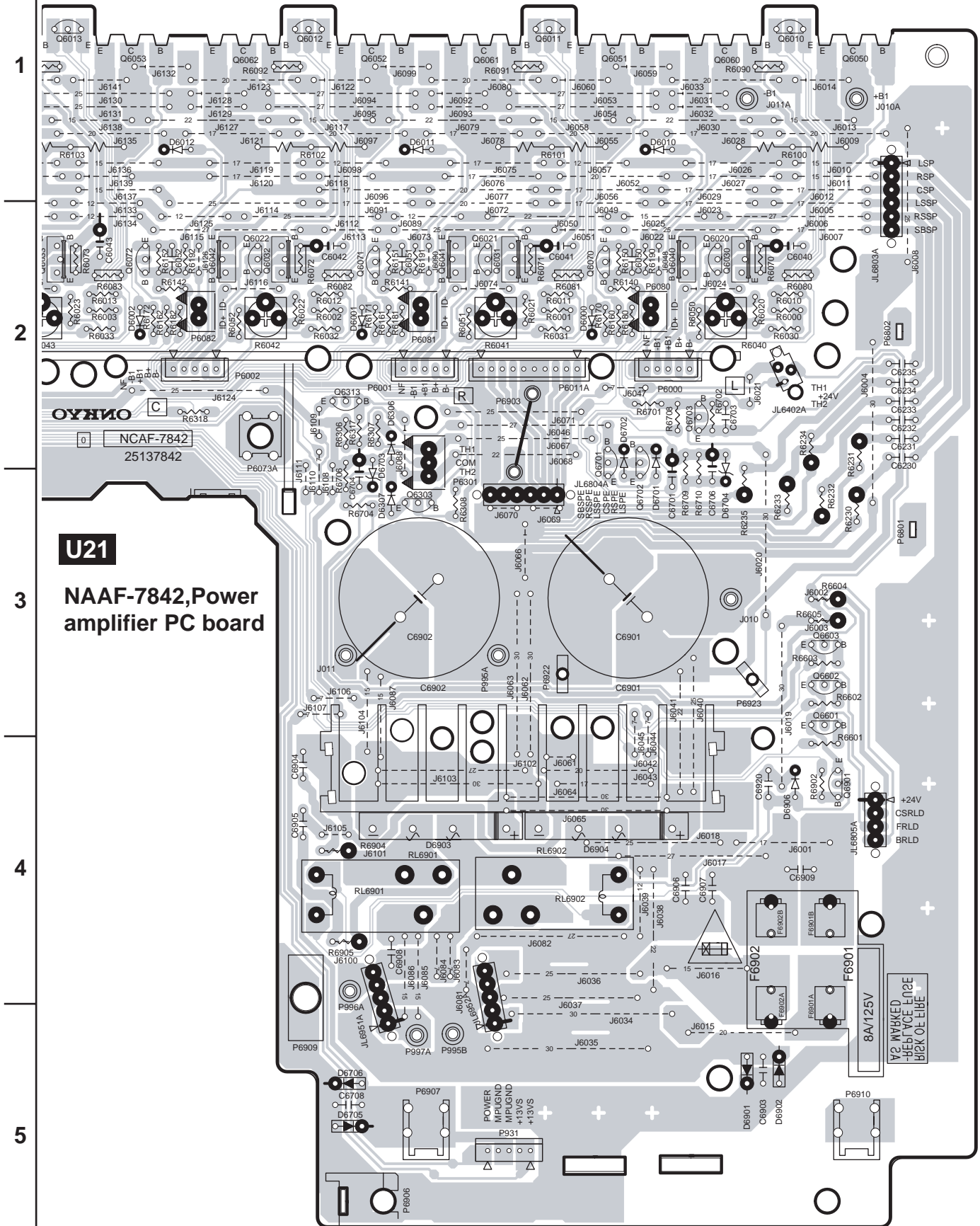

U21
NAAF-7842, Power amplifier PC board

8A/125V
 V2 MYBKED
 -BEETVCE LINE
 BIKX OF LINE

A B C D
PRINTED CIRCUIT BOARD VIEW 5

1

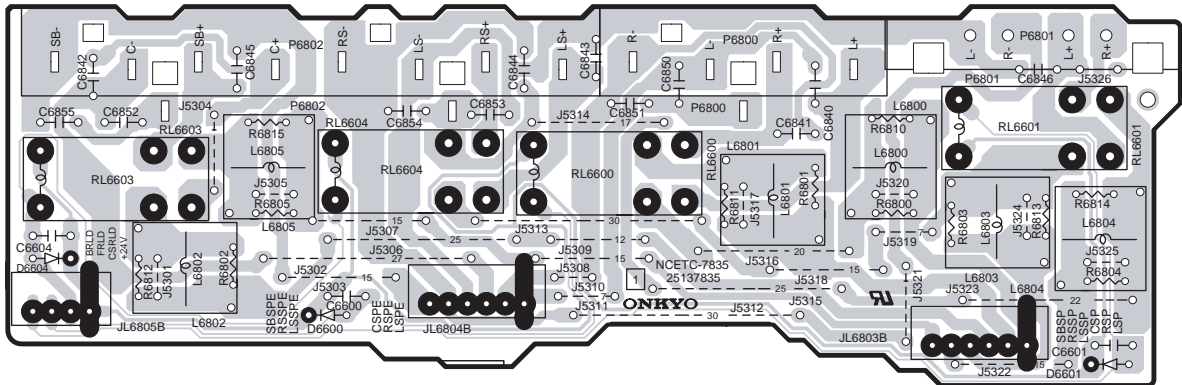

2

U14 NAETC-7835, Speaker terminal PC board

3

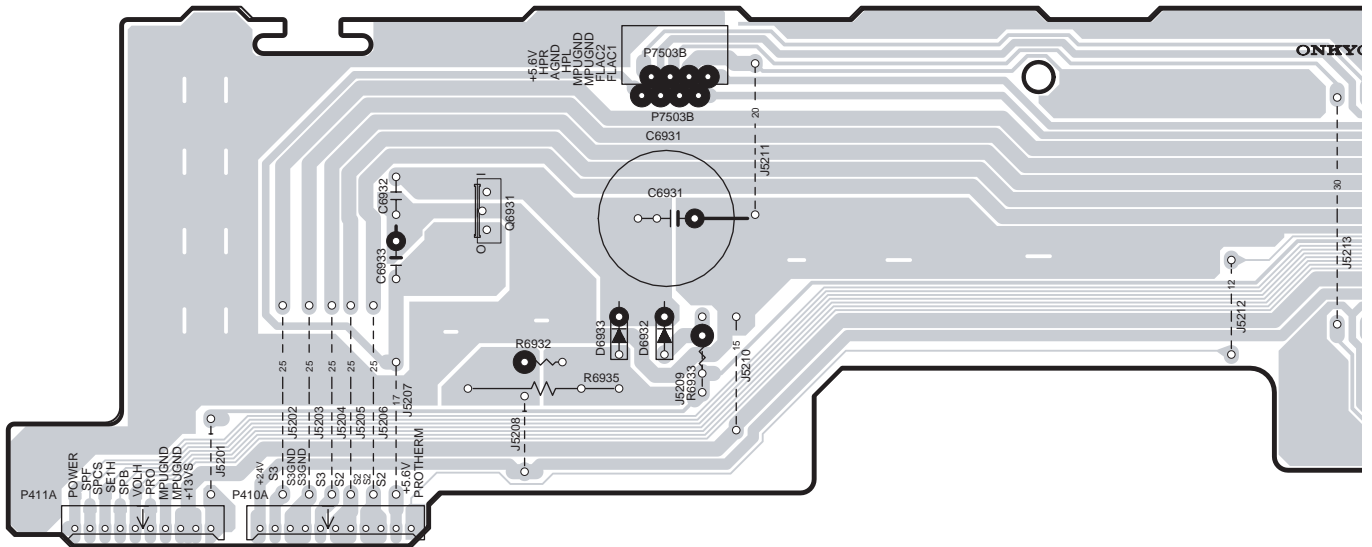

4

U12 NAETC-7833, Const. Voltage circuit PC board

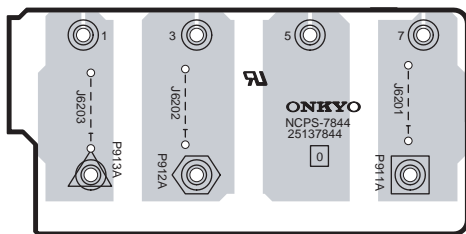

5

U23 NAPS-7844, Transformer terminal PC board

A

B

C

D

PRINTED CIRCUIT BOARD VIEW 2

U1 NADG-7821,DSP circuit PC board

1

2

3

4

5

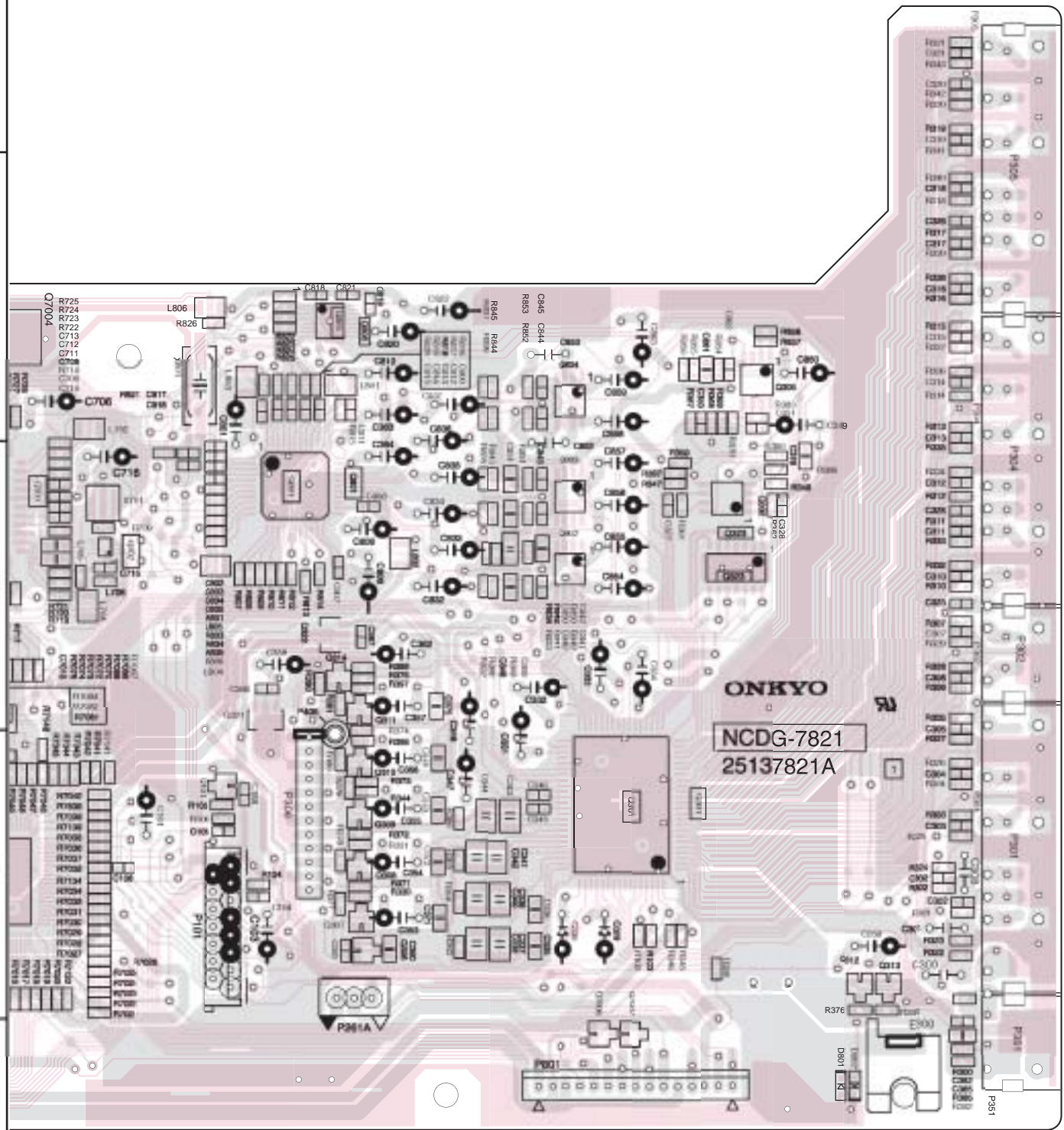

A

B

C

D

PRINTED CIRCUIT BOARD VIEW 3
Video section

1

2

3

4

5

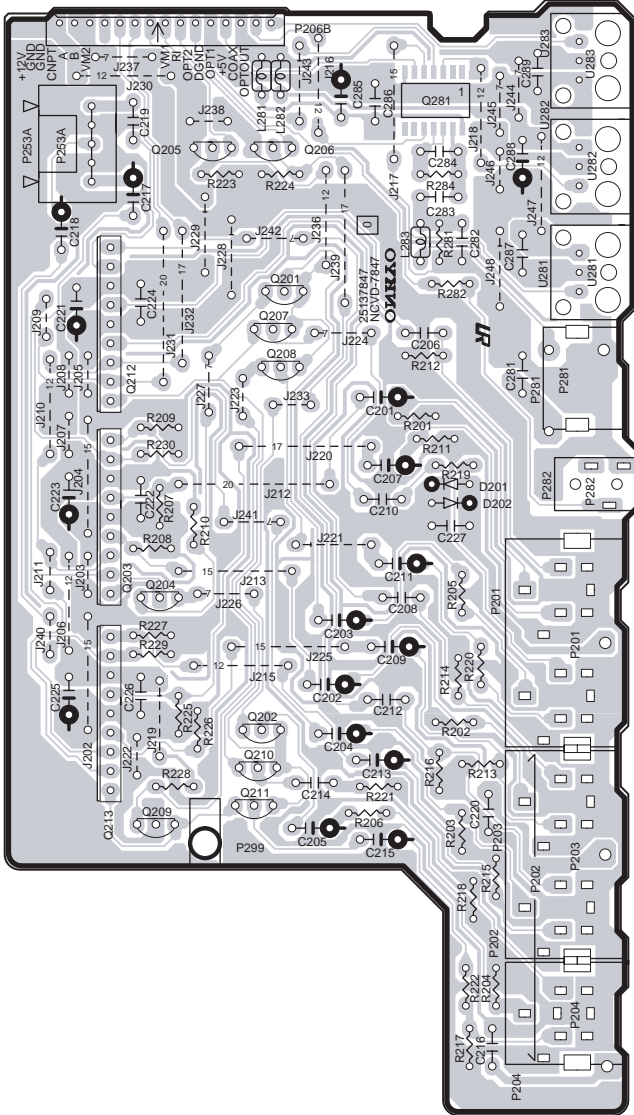

U26 NAVD-7847, Video circuit PC board

U9 NAAF-7830, Driver circuit PC board

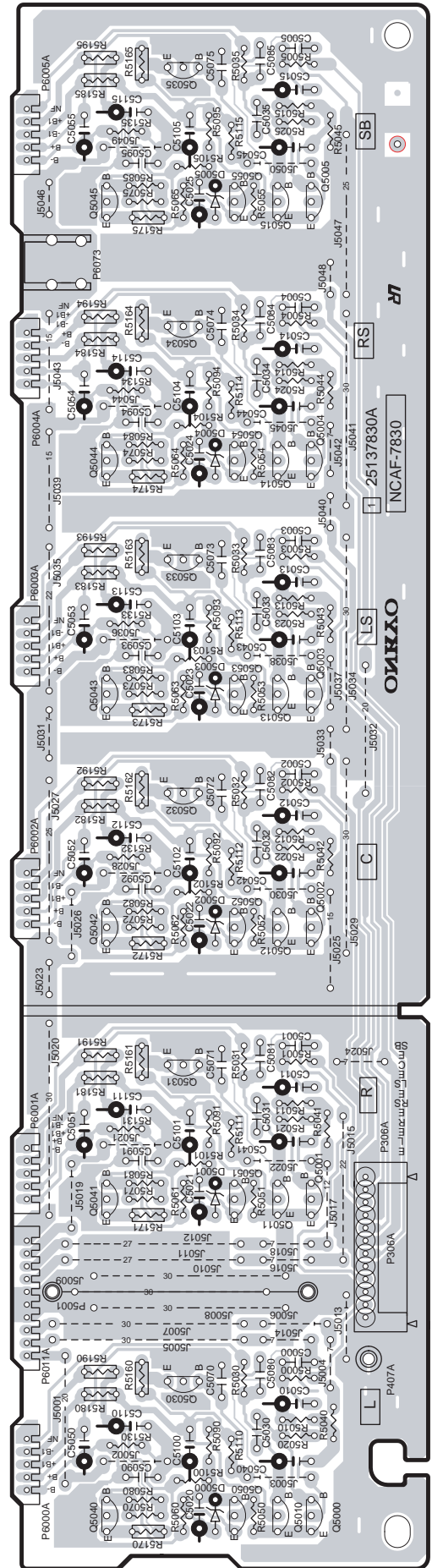

IC BLOCK DIAGRAMS AND DESCRIPTIONS

AK4384(106dB 192kHz 24-Bit 2ch DAC)

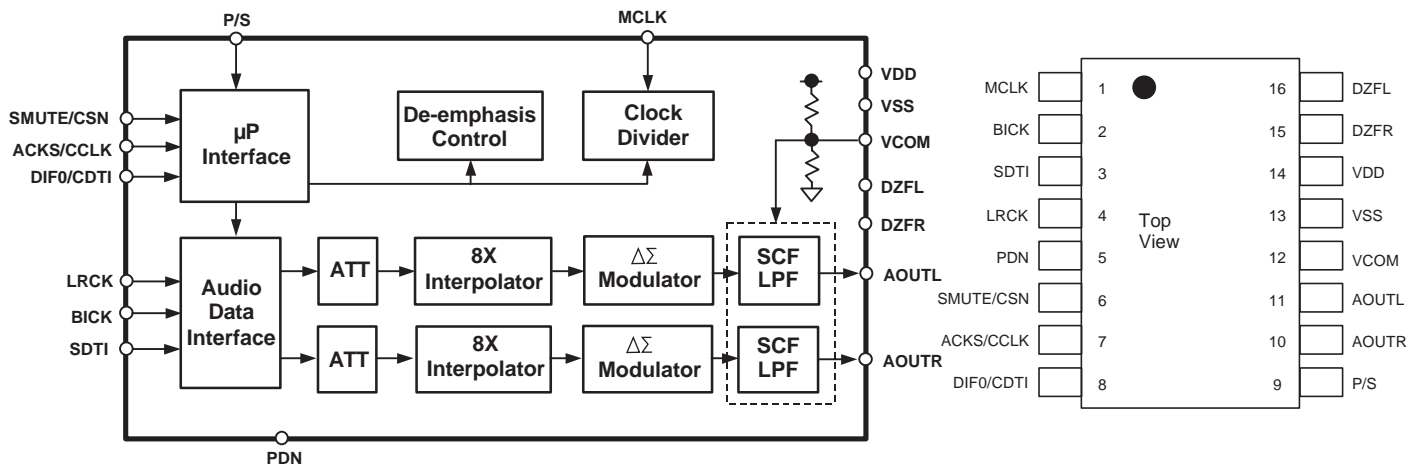

No.	Pin Name	I/O	Function
1	MCLK	I	Master Clock Input Pin An external TTL clock should be input on this pin.
2	BICK	I	Audio Serial Data Clock Pin
3	SDTI	I	Audio Serial Data Input Pin
4	LRCK	I	L/R Clock Pin
5	PDN	I	Power -Down Mode Pin When at "L", the AK4384 is in the power-down mode and is held in reset. The AK4384 should always be reset upon power-up.
6	SMUTE	I	Soft Mute Pin in parallel mode "H": Enable, "L": Disable
7	CSN	I	Chip Select Pin in serial mode
	ACKS	I	Auto Setting Mode Pin in parallel mode "L": Manual Setting Mode, "H": Auto Setting Mode
	CCLK	I	Control Data Clock Pin in serial mode
8	DIF0	I	Audio Data Interface Format Pin in parallel mode
	CDTI	I	Control Data Input Pin in serial mode
9	P/S	I	Parallel/Serail Select Pin (Internal pull-up pin) "L": Serial control mode, "H": Parallel control mode
10	AOUTR	O	Rch Analog Output Pin
11	AOUTL	O	Lch Analog Output Pin
12	VCOM	O	Common Voltage Pin, VDD/2 Normally connected to VSS with a 0.1mF ceramic capacitor in parallel with a 10 m F electrolytic cap.
13	VSS	-	Ground Pin
14	VDD	-	Power Supply Pin
15	DZFR	O	Rch Data Zero Input Detect Pin
16	DZFL	O	Lch Data Zero Input Detect Pin

IC BLOCK DIAGRAMS AND DESCRIPTIONS

CS493264(DSP IC)

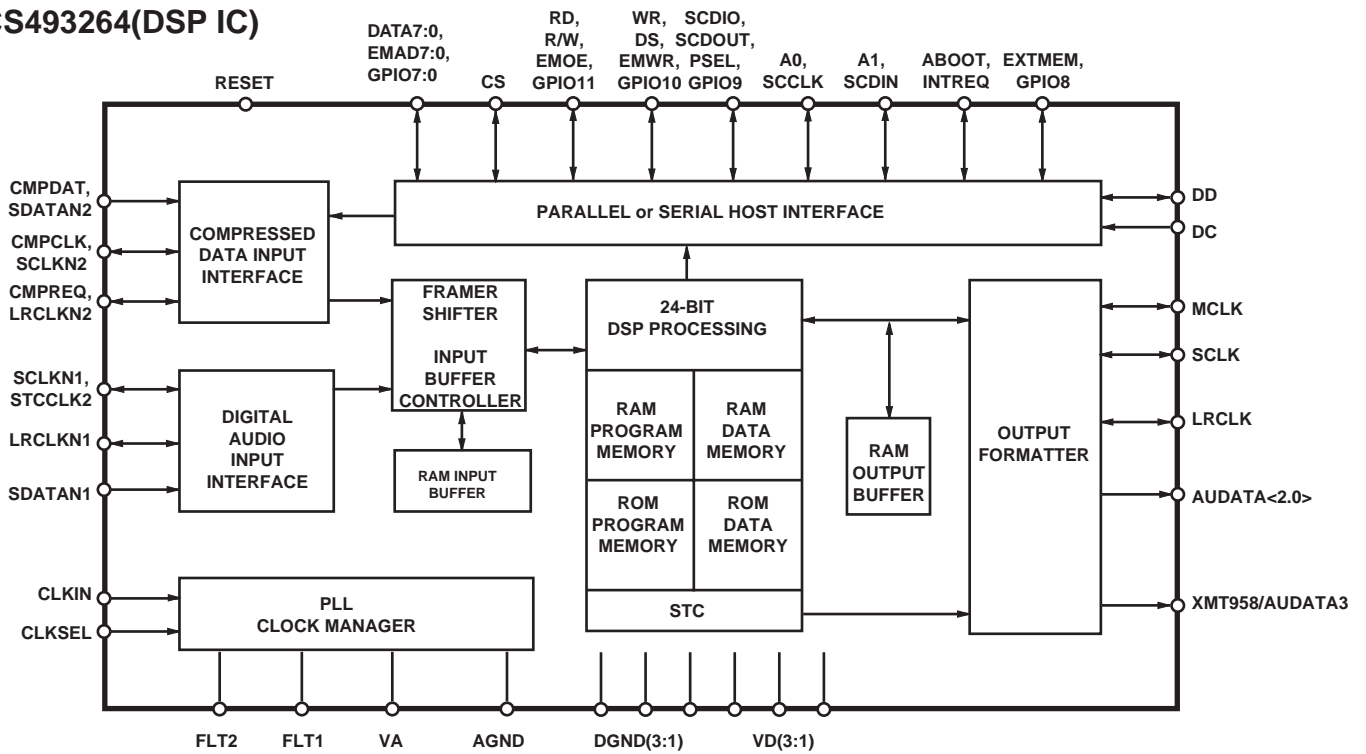

No.	Symbol	Description
1	VD1	Digital positive supply
2	DGMD1	Digital supply ground
3	AUDATA3,XMT958	SPDIF transmitter output. Digital audio output.
4	WR,DS,EMWR,GPIO10	Host write strobe or host data strobe or external memory write enable or general purpose input & output number 10.
5	RD,R/W,EMOE,GPIO11	Host parallel output enable or host parallel R/W or external memory output enable or general purpose input & output number 11.
6	A1,SCDIN	Host address bit one or SPI serial control data input.
7	A0,SCCLK	Host parallel address bit zero or serial control port clock.
8	DATA7	In parallel host mode these pins provide a bi-directional data bus. If a serial host mode is selected, these pins can provide a multiplexed address and data bus for connecting an 8-bit external memory. Otherwise, in serial data host mode, these pins can act as general-purpose input or output pins that can be individually configured by this DSP.
9	DATA6	
10	DATA5	
11	DATA4	
12	VD2	Digital positive supply
13	DGND2	Digital supply ground
14	DATA3	In parallel host mode these pins provide a bi-directional data bus. If a serial host mode is selected, these pins can provide a multiplexed address and data bus for connecting an 8-bit external memory. Otherwise, in serial data host mode, these pins can act as general-purpose input or output pins that can be individually configured by this DSP.
15	DATA2	
16	DATA1	
17	DATA0	
18	CS	Host parallel chip select, host serial SPI chip select pin.
19	SCDIO,SCDOUT,PSEL,GPIO8	Serial control port data input and output, parallel port type select pin.
20	INTREQ,ABOOT	Control port interrupt request, automatic boot enable
21	EXTMEM	External memory chip select or general purpose input & output number pin
22	SDATAN1	PCM audio data input number one
23	VD3	Digital positive supply
24	DGND3	Digital supply ground
25	SCLK1,STCLK2	PCM audio data input bit clock
26	LRCLKN1	PCM audio input sample rate clock
27	CMPDAT,ECV958,SDATAN2	PCM audio data input number two.
28	CMPCLK,SCLKN2	PCM audio input bit clock
29	CMPREQ,LRCLKN2	PCM audio input sample rate clock
30	CLKIN	Master clock input pin
31	CLKSEL	DSP clock select pin
32	FILT2	Connect to an external filter for phase-locked loop.
33	FILT1	Connect to an external filter for phase-locked loop.
34	VA	Analog positive supply.
35	AGND	Analog supply ground/
36	RESET	Master reset input
37	DD	These pins are reserved and should be pulled up with an external 4.7k resistors.
38	DC	
39	AUDATA2	Digital audio output 2.
40	AUDATA1	Digital audio output 1.
41	AUDATA0	Digital audio output 0.
42	LRCLK	Audio output sample rate clock
43	SCLK	audio output bit clock
44	MCLK	Audio master clock

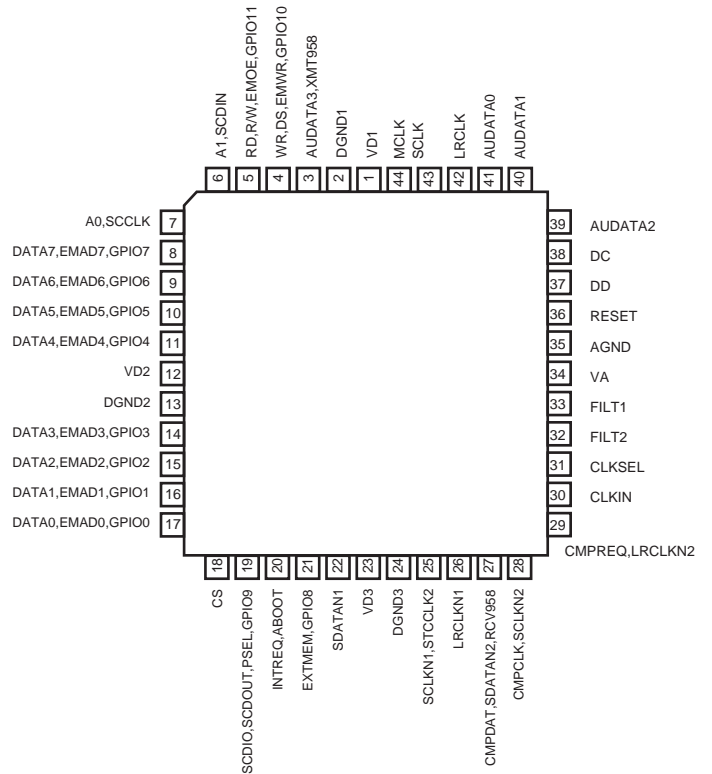

IC BLOCK DIAGRAMS AND DESCRIPTIONS

BU1923F(RDS Decoder)

BLOCK DIAGRAM

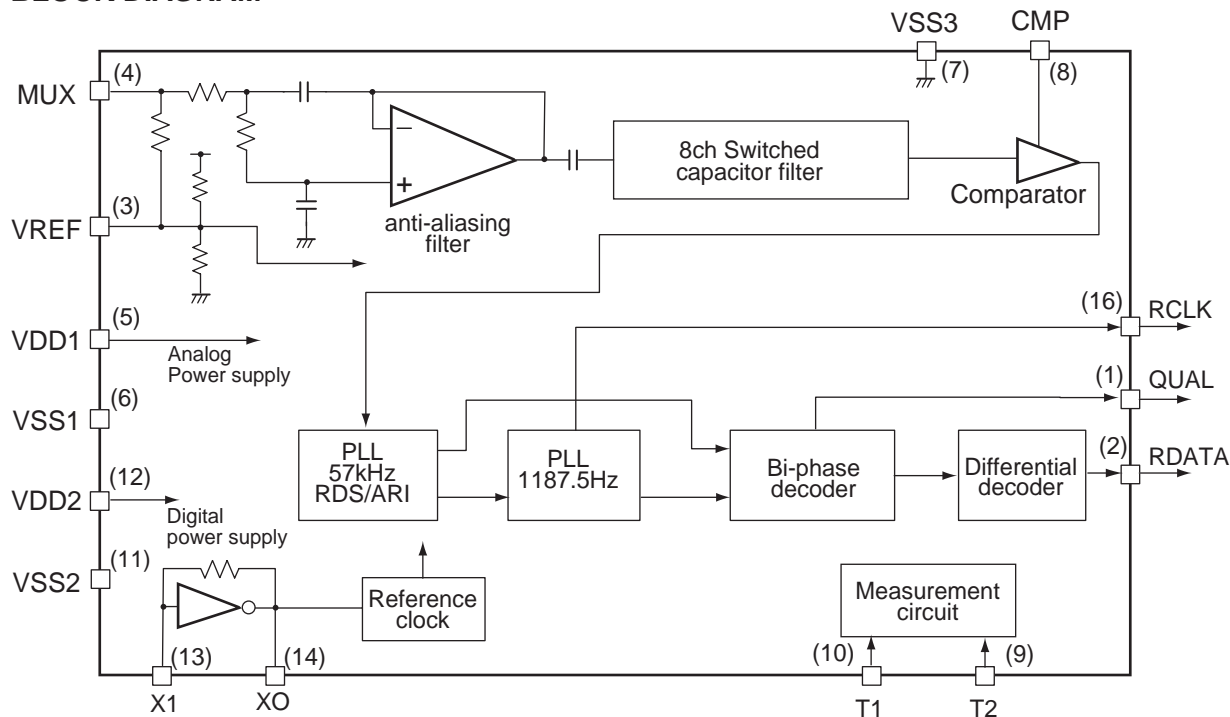

TERMINAL DESCRIPTION

Pin No.	Symbol	Pin name	Function
1	QUAL	Demodulator quality	Good data : High , Bad data : Low
2	RDATA	Demodulator data	RDS data output
3	Vref	Reference voltage	1/2 VDD1
4	MUX	Input	Composite signal input
5	VDD1	Analog power supply	4.5V to 5.5V
6	Vss1		
7	Vss3	GND	-
8	CMP	Comparator input	C-junction
9	T2	Test input	Open or connected to ground
10	T1		
11	VDD2	Digital power supply	4.5V to 5.5V
12	Vss2		
13	XI	Crystal oscillator	Connects to 4.332MHz oscillator
14	XO		
15	(NC)	-	-
16	RCLK	Demodulator clock	1187.5Hz clock

IC BLOCK DIAGRAMS AND DESCRIPTIONS

BD3812F(Audio Sound Processor)

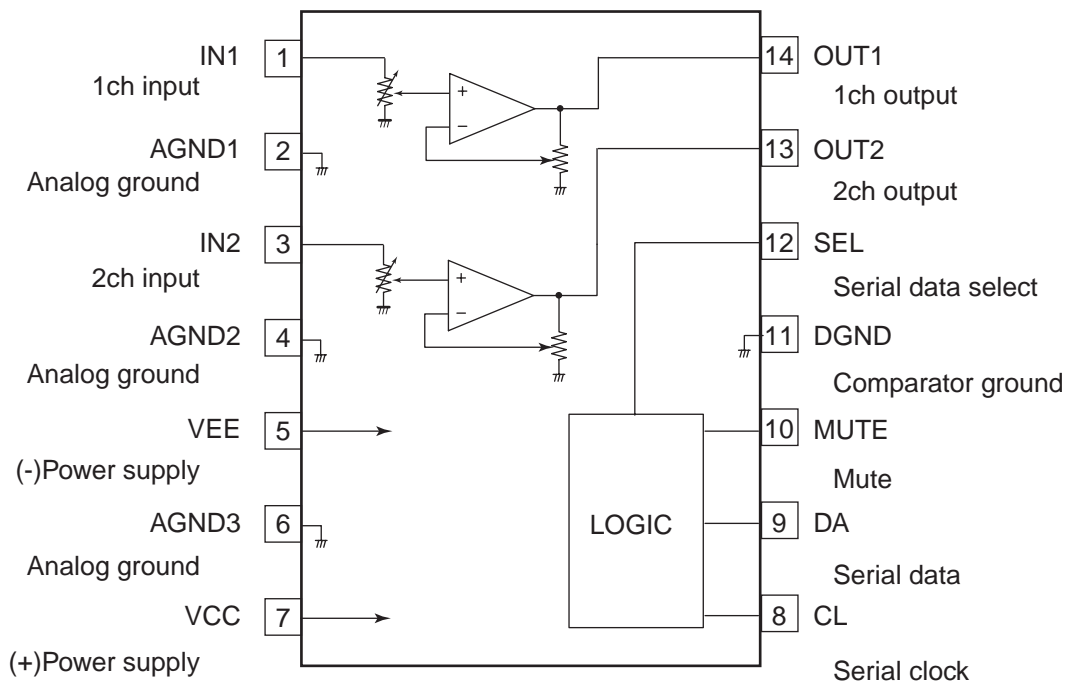

MX27L2000TC-12(2M-Bit CMOS EPROM)

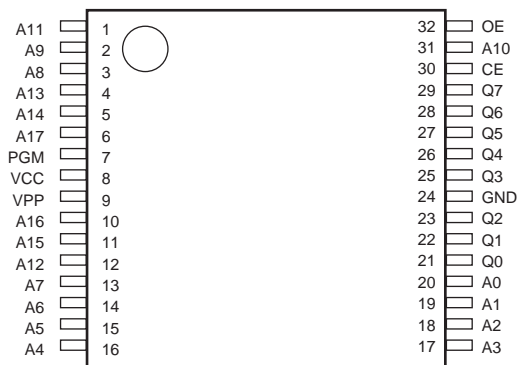

PIN DESCRIPTION

SYMBOL	PIN NAME
A0-A17	Address Input
Q0-Q7	Data Input/Output
CE	Chip Enable Input
OE	Output Enable Input
PGM	Programmable Enable Input
VPP	Program Supply Voltage
NC	No Internal Connection
VCC	Power Supply Pin (+5V)
GND	Ground Pin

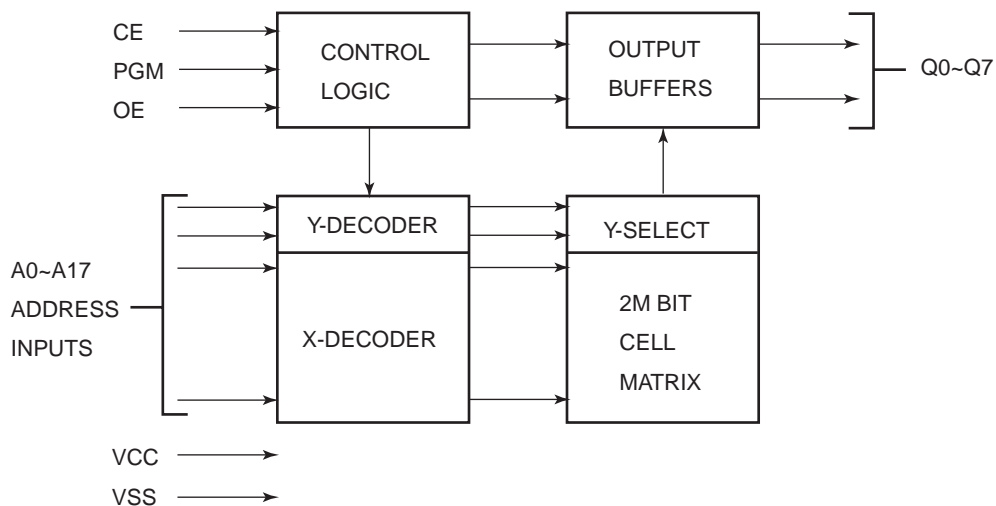

IC BLOCK DIAGRAMS AND DESCRIPTIONS

BD3811K1(6ch Volume with 8ch input selector)

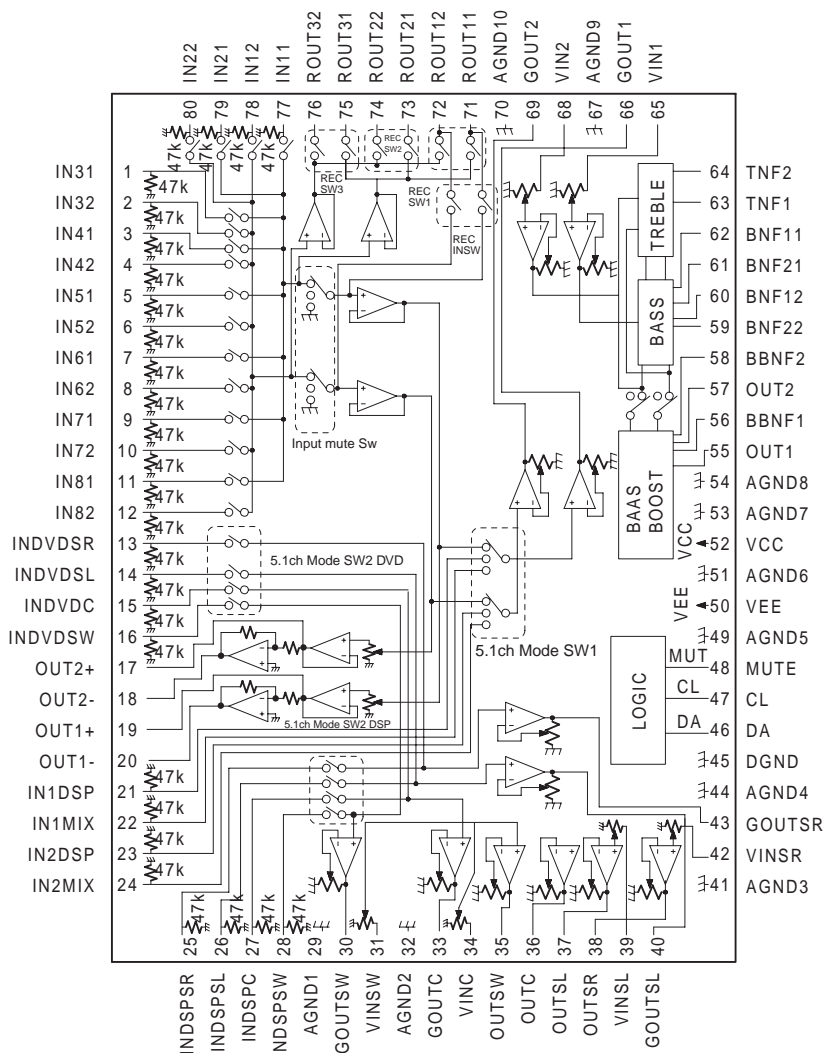

No.	Terminal	Description
26	INDSPSL	DSP surround Lch input terminal
27	INDSPC	DSP center input terminal
28	INDSPSW	DSP sub woofer input terminal
29	AGND1	Analog ground terminal
30	GOUTSW	Sub woofer input gain output terminal
31	VINSW	Sub woofer volume input terminal
32	AGND2	Analog ground terminal
33	GOUTC	Center input gain out put terminal
34	VINC	Center volume input terminal
35	OUTSW	Sub woofer output terminal
36	OUTC	Center output terminal
37	OUTSL	Surround Lch output terminal
38	OUTSR	Surround Rch output terminal
39	VINSL	Surround Lch volume input terminal
40	GOUTSL	Surround Lch input gain output terminal
41	AGND3	Analog ground terminal
42	VINSR	Surround Rch volume input terminal
43	GOUTSR	Surround Rch input gain output terminal
44	AGND4	Analog ground terminal
45	DGND	Ground terminal for comparator
46	DA	Serial data and latch input terminal
47	CL	Serial clock input terminal
48	MUTE	Mute terminal
49	AGND5	Analog ground terminal
50	VEE	(-) Power supply terminal
51	AGND6	Analog ground terminal
52	VCC	(+) Power supply terminal
53	AGND7	Analog ground terminal
54	AGND8	Analog ground terminal
55	OUT1	1ch output terminal
56	BBNF1	1ch bass boost filter terminal
57	OUT2	2ch output terminal
58	BBNF2	2ch bass boost filter terminal
59	BNF22	2ch bass filter terminal 2
60	BNF12	2ch bass filter terminal 1
61	BNF21	1ch bass filter terminal 2
62	BNF11	1ch bass filter terminal 1
63	TNF1	1ch treble filter terminal 1
64	TNF2	2ch treble filter terminal 1
65	VIN1	1ch(Lch) volume input terminal
66	GOUT1	1ch(Lch) input gain output terminal
67	AGND9	Analog ground terminal
68	VIN2	2ch(Rch) volume input terminal
69	GOUT2	2ch(Rch) input gain output terminal
70	AGND10	Analog ground terminal
71	ROUT11	1ch recording input/output terminal 1
72	ROUT12	2ch recording input/output terminal 1
73	ROUT21	1ch recording output terminal 2
74	ROUT22	2ch recording output terminal 2
75	ROUT31	1ch recording output terminal 3
76	ROUT32	2ch recording output terminal 3
77	IN11	1ch input terminal 1
78	IN12	2ch input terminal 1
79	IN21	1ch input terminal 2
80	IN22	2ch input terminal 2

No.	Terminal	Description
1	IN31	1ch input terminal 3
2	IN32	2ch input terminal 3
3	IN41	1ch input terminal 4
4	IN42	2ch input terminal 4
5	IN51	1ch input terminal 5
6	IN52	2ch input terminal 5
7	IN61	1ch input terminal 6
8	IN62	2ch input terminal 6
9	IN71	1ch input terminal 7
10	IN72	2ch input terminal 7
11	IN81	1ch input terminal 8
12	IN82	2ch input terminal 8
13	INDVDSR	DVD surround Rch input terminal
14	INDVDSL	DVD surround Lch input terminal
15	INDVDC	DVD center input terminal
16	INDVDSW	DVD sub woofer input terminal
17	OUT2(+)	2ch (+) A/D output terminal
18	OUT2(-)	2ch (-) A/D output terminal
19	OUT1(+)	1ch (+) A/D output terminal
20	OUT1(-)	1ch (-) A/D output terminal
21	IN1DSP	1ch DSP input terminal
22	IN1MIX	1ch DSP MIX input terminal
23	IN2DSP	2ch DSP input terminal
24	IN2MIX	2ch DSP MIX input terminal
25	INDSPSR	DSP surround Rch input terminal

IC BLOCK DIAGRAMS AND DESCRIPTIONS

AK4586VQ(96kHz 6ch CODEC)

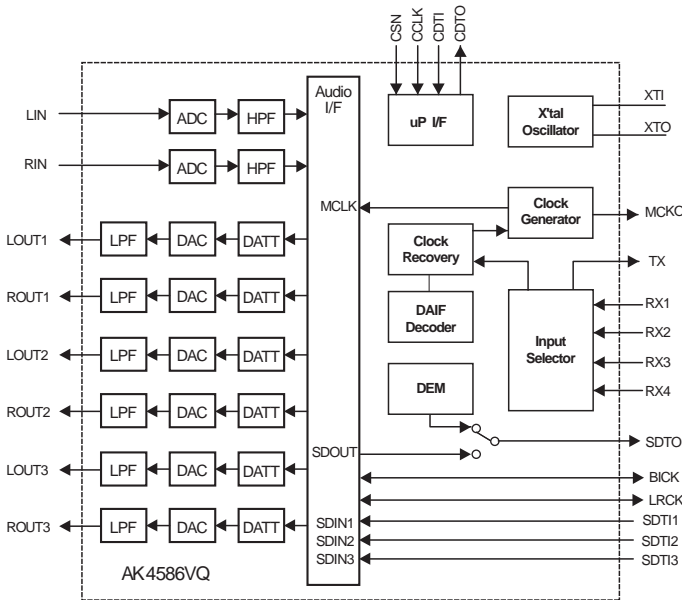
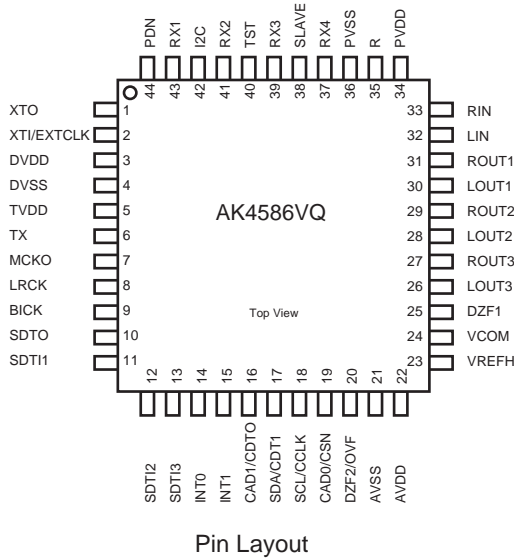

No.	Name	I/O	Description
1	XTO	O	Crystal oscillator output pin
2	XTI	I	Crystal oscillator input pin
3	EXTCLK	I	Master clock input pin
4	TVDD	-	Power supply pin for output buffer. 2.7V to 5.5V
4	DVSS	-	Digital ground pin
5	DVDD	-	Power supply pin for digital section. 4.5V to 5.5V
6	TX	O	Transmitter channel output pin
7	MCKO	O	Master clock output pin
8	LRCK	I/O	Input/Output channel clock pin
9	BICK	I/O	Audio serial data clock pin
10	SDTO	O	Audio serial data output pin
11	SDTI1	I	Audio serial data input pin for DAC1
12	SDTI2	I	Audio serial data input pin for DAC2
13	SDTI3	I	Audio serial data input pin for DAC3
14	INT0	O	Interrupter pin 0
15	INT1	O	Interrupter pin 1
16	CDTO	O	Control data output pin (Serial mode)
16	CADI	I	Chip address pin 1 (Bus mode)
17	CDTI	I	Control data input pin (Serial mode)
17	SDA	I/O	Control data input/output pin (Bus mode)
18	CCLK	I	Control data clock pin (Serial mode)
18	SCL	I	Control data clock pin (Bus mode)
19	CSN	I	Chip select pin (Serial mode)
19	CAD0	I	Chip address pin 0 (Bus mode)
20	DZF2	O	Zero input detection pin 2
20	OVF	O	Overflow detection pin for analog input
21	AVSS	-	Analog ground pin
22	AVDD	-	Power supply pin for analog section. 4.5V to 5.5V
23	VREFH	I	Reference voltage input pin, AVDD
24	VCOM	O	Common voltage output pin, AVDD/2
25	DZF1	O	Zero input detection pin 1
26	LOUT3	O	DAC 3 left channel analog output pin
27	ROUT3	O	DAC 3 right channel analog output pin
28	LOUT2	O	DAC 2 left channel analog output pin
29	ROUT2	O	DAC 2 right channel analog output pin
30	LOUT1	O	DAC 1 left channel analog output pin
31	ROUT1	O	DAC 1 right channel analog output pin
32	LIN	I	Left channel analog input pin
33	RIN	I	Right channel analog input pin
34	PVDD	-	PLL power supply pin. 4.5V to 5.5V
35	R	-	External resistor connection pin
36	PVSS	-	PLL ground pin
37	RX4	I	Receiver channel input pin 4
38	SLAVE	I	Slave mode pin
39	RX3	I	Receiver channel input pin 3
40	TST	I	Test pin
41	RX2	I	Receiver channel input pin 2
42	I2C	I	Serial control mode select pin. Serial at H.
43	RX1	I	Receiver channel input pin 1
44	PDN	I	Power down and reset pin

LA7956(Video Switch)

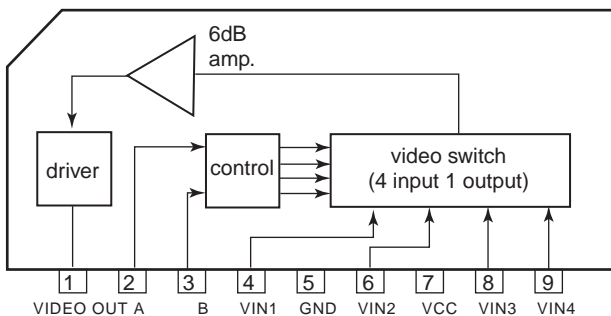

S2	S3	VIN1	VIN2	VIN3	VIN4
(2 pin)	(3 pin)	(4 pin)	(6 pin)	(8 pin)	(9 pin)
H	H	ON	OFF	OFF	OFF
L	H	OFF	ON	OFF	OFF
H	L	OFF	OFF	ON	OFF
L	L	OFF	OFF	OFF	ON

IC BLOCK DIAGRAMS AND DESCRIPTIONS

TC74VHC541FT(Octal bus buffer)

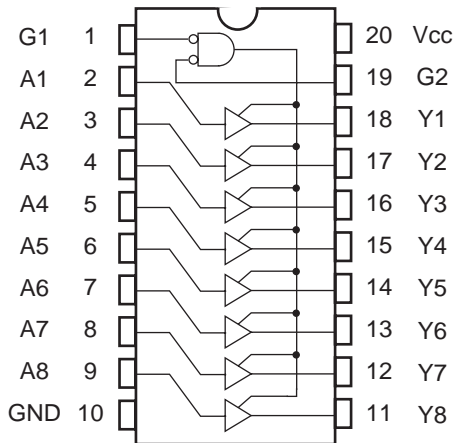

INPUTS			OUTPUT
$\overline{G1}$	$\overline{G2}$	An	
H	X	X	Z
X	H	X	Z
L	L	H	H
L	L	L	L

X :Don't care
Z :High impedance

TC7HTC7007AF(Hex buffer)

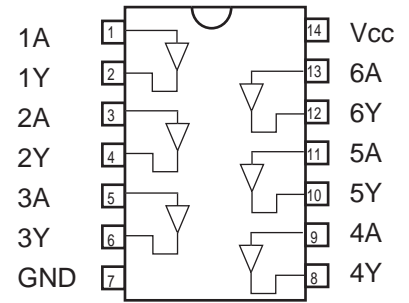

TC7WU04FU(Triple inverter)

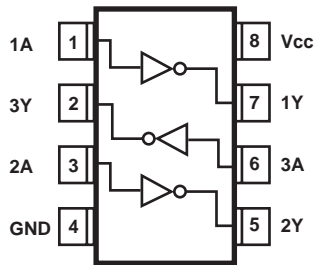

74HCU04F(Hex Inverter)

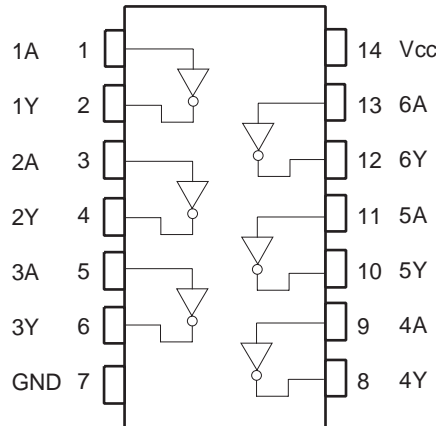

Truth table

A	Y
L	H
H	L

(TOP VIEW)

TC74VHC574FT(Octal D-FF with 3-state output)

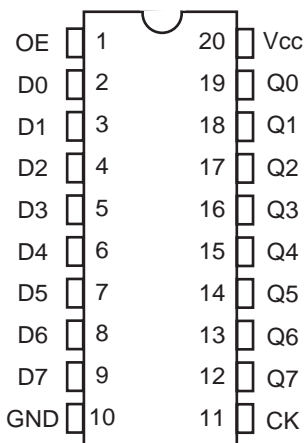

INPUTS			OUTPUT
\overline{OE}	CK	D	
H	X	X	Z
L	\downarrow	X	Qn
L	\uparrow	L	L
L	\uparrow	H	H

X :Don't care
Z :High impedance
Qn :No change

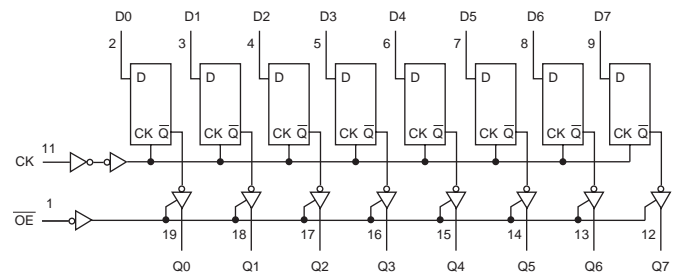

MAIN MICROPROCESSOR-CONNECTION DIAGRAM

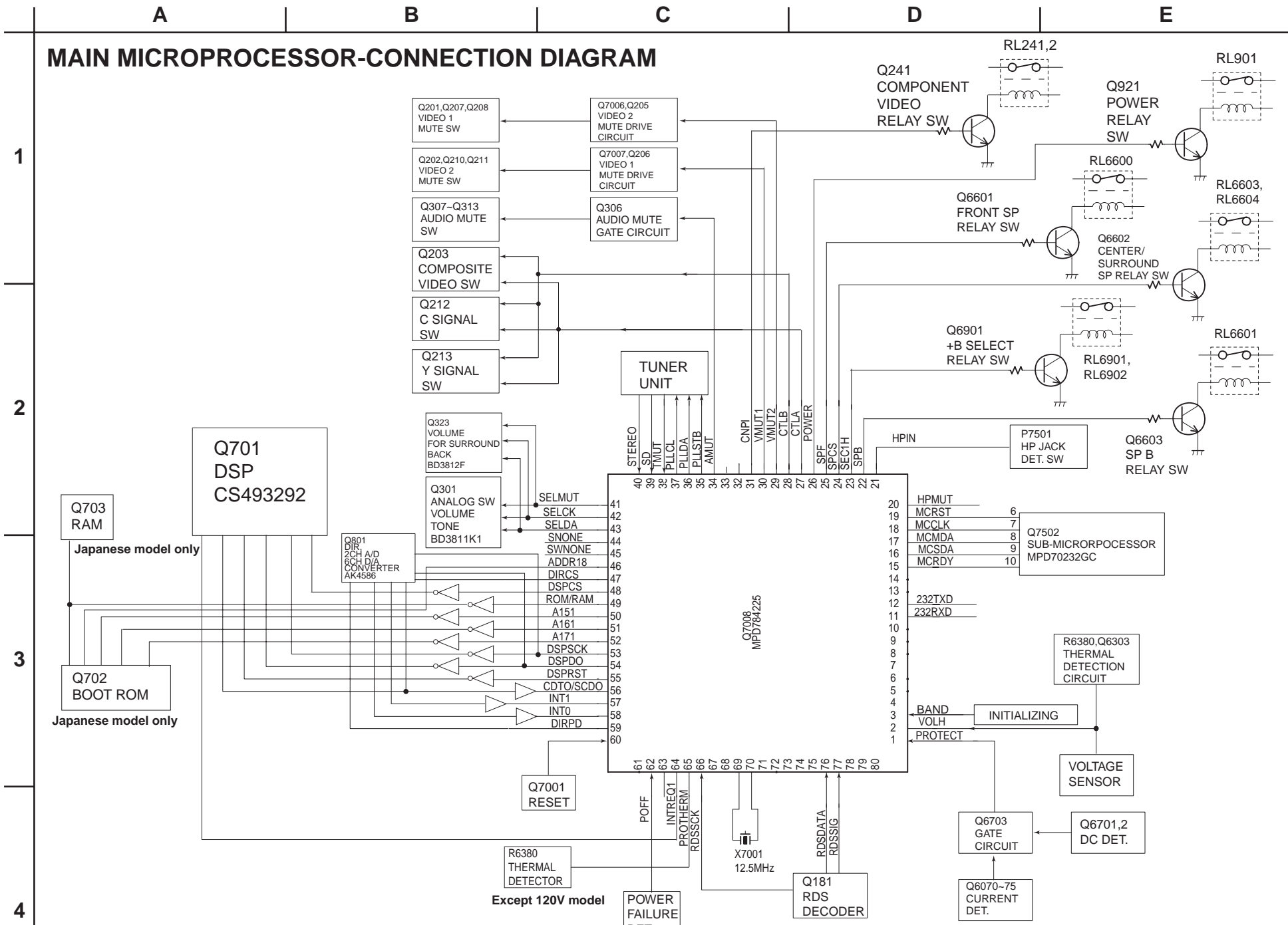

1

2

3

4

Except 120V model

European model only

SUB-MICROPROCESSOR CONNECTION DIAGRAM

1

2

3

4

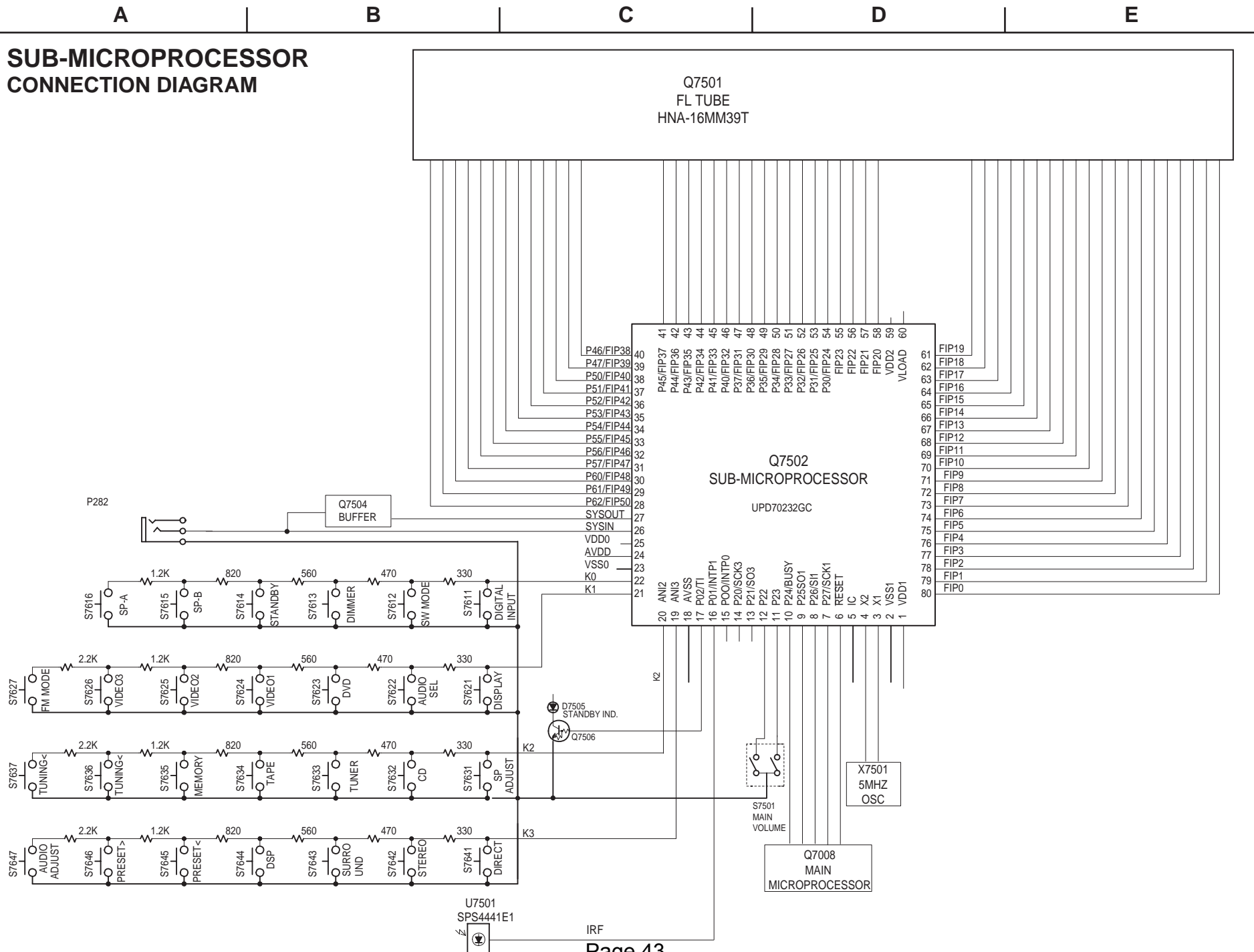

TERMINAL DESCRIPTION

MAIN MICROPROCESSOR

No.	Terminal	I/O	Description
1	PROTECT	I	Protection circuit detection input terminal
2	VOLH	I	Power amplifier voltage detection terminal.
3	BAND	I	Region setting input terminal.
11	232TXD		Not used.
15	MCRDY	I	Data ready detection input terminal from the sub microprocessor.
16	MCSDa	I	Data input terminal from the sub microprocessor.
17	MCMDA	O	Data output terminal to the sub microprocessor.
18	MCCLK	O	Serial clock output terminal to the sub microprocessor
19	-MCRST	O	Reset signal output terminal to the sub microprocessor
20	HPMUT	O	Muting control output terminal for headphone amplifier.
21	HPIN	I	Input terminal to detect the connection of headphone
22	SPBRL	O	Speaker B relay control output terminal.
23	SEC1H	O	Voltage +/-B control output terminal.
24	SPAC SRL	O	Speaker relay control output terminal for center and surround channels
25	SPAFRL	O	Speaker relay A control output terminal for front channels
26	POWERRL	O	Power source relay control output terminal
27	VCTRLA	O	Control signal A output terminal for the video selector switch
28	VCTRLB	O	Control signal B output terminal for the video selector switch
29	VMUT2	O	Muting control output terminal for the video section 2
30	VMUT1	O	Muting control output terminal for the video section 1
31	CNPI	O	Componet video relay control output
34	AMUT	O	Audio muting control output terminal
35	PLLSTB	O	Strobe signal output terminal to PLL IC
36	PLLSDO	O	Serial data output terminal to PLL IC
37	PLLCLK	O	Serial clock output terminal to PLL IC
38	TUMUT	O	Muting control output terminal for the tuner section
39	-SD	I	Broadcast detection input terminal more than a muting level.
40	-STEREO	I	FM stereo broadcast detection input terminal
41	SELMUT	O	Muting control output terminal for selector, volume and tone IC BD3811.
42	SELCLK	O	Serial clock output terminal of IC BD3811.
43	SELSDO	O	Serial data and latch signal output terminal for IC BD3811
44	SNONE	O	Not used.
45	SWNONE	O	Not used.
46	ADDR181	O	DSP boot ROM address 18 select terminal. Not used.
47	-DIRCS	O	Chip select signal output terminal to DIR IC AK4586
48	-DSPCS	O	Chip select signal output terminal to DSP IC.
49	-ROM/RAM	O	ROM/RAM select terminal. Not used.
50	ADDR151	O	DSP boot ROM address 15 select terminal. Not used.
51	ADDR161	O	DSP boot ROM address 16 select terminal. Not used.
52	ADDR171	O	DSP boot ROM address 17 select terminal. Not used.
53	DSPCLK	O	Serial clock output terminal for DIR and DSP ICs.
54	DSPSDO	O	Serial data output terminal for DIR and DSP ICs.
55	-DSPRST	O	Reset signal output terminal to DSP IC.
56	CDTO/SCDO	I	Serial data input terminal from DIR and DSP ICs.
57	INT1	I	Input terminal to detect the status of DIR IC.
58	INT0	I	Input terminal to detect the unlock of DIR IC.
59	-DIRPD	O	Power down terminal to DIR and CODEC ICs.
60	RESET	I	Reset input terminal
62	POFF	I	Power failure detection input terminal
64	-INTREQ	I/O	Interrupter input terminal from DSP IC.
65	PROTHERM	I	Theraml detector input
66	-RDSCCLK	I	RDS clock input terminal (European model only)
69	X2		Connect the ceramic oscillator 12.5MHz.
70	X1		Connect the ceramic oscillator 12.5MHz.
71	TEST/VPP		Test terminal.
72,3	XT2,XT1		Not used.
76	RDS DATA	I	Data input terminal of RDS broadcast (European model only)
77	RDSSIG	I	Input terminal to check the signal of RDS broadcast (European model only)

TERMINAL DESCRIPTION

SUB MICROPROCESSOR

Pin No.	Symbol	I/O	Description	Pin No.	Symbol	I/O	Description
1	VDD		Power supply terminal. Connect to 5V.	41	P22	O	Segment output terminal of P22.
2	VSS		Ground terminal.	42	P21	O	Segment output terminal of P21.
3	X1		Ceramic oscillator connection terminals for main system.	43	P20	O	Segment output terminal of P20.
4	X2		Connect the 5MHz ceramic oscillator between #3 and #4.	44	P19	O	Segment output terminal of P19.
5	IC/VPP		Internal connection terminal	45	P18	O	Segment output terminal of P18.
6	~RESET	I	System reset signal input terminal.	46	P17	O	Segment output terminal of P17.
7	SUBCL/SCK	I	Clock input terminal to transmit the signal from main microprocessor.	47	P16	O	Segment output terminal of P16.
8	SUBDO/SDI	I	Data input terminal to transmit the signal from main microprocessor.	48	P15	O	Segment output terminal of P15.
9	SUBDI/SDD	O	Data output terminal to transmit the signal to main microprocessor.	49	P14	O	Segment output terminal of P14.
10	SUBLDY	O	Data ready output terminal to transmit to the main microprocessor.	50	P13	O	Segment output terminal of P13.
11	VBJ	I	Pulse input terminal from the rotary encoder of volume.	51	P12	O	Segment output terminal of P12.
12	VAJ	I	Pulse input terminal from the rotary encoder of volume.	52	P11	O	Segment output terminal of P11.
13	SSCBJ	I	Not used.	53	P10	O	Segment output terminal of P10.
14	SSCAJ	I	Not used.	54	P9	O	Segment output terminal of P9.
15	~IRIN	I	Not used.	55	P8	O	Segment output terminal of P8.
16	~IRF	I	Signal input terminal from the remote controller.	56	P7	O	Segment output terminal of P7.
17	STBYLED	O	Standby LED control output terminal.	57	P6	O	Segment output terminal of P6.
18	AVSS		Ground terminal for A/D converter.	58	P5	O	Segment output terminal of P5.
19	K3	I	Operation key connection terminal.	59	VDD2		Power supply terminal. Apply +5V.
20	K2	I	Operation key connection terminal.	60	VLOAD		Negative power supply terminal of FL controller.
21	K1	I	Operation key connection terminal.	61	P4	O	Segment output terminal of P4.
22	K0	I	Operation key connection terminal.	62	P3	O	Segment output terminal of P3.
23	VSS0		Ground terminal	63	P2	O	Segment output terminal of P2.
24	AVDD		Power supply terminal for A/D converter.	64	P1	O	Segment output terminal of P1.
25	VDDD		Power supply terminal. Apply +5V.	65	16G	O	Grid output terminal of 16G.
26	~SYSIN	I	System code input terminal.	66	15G	O	Grid output terminal of 15G.
27	~SYSOUT	O	System code output terminal.	67	14G	O	Grid output terminal of 14G.
28	P35	O	Segment output terminal of P35.	68	13G	O	Grid output terminal of 13G.
29	P34	O	Segment output terminal of P34.	69	12G	O	Grid output terminal of 12G.
30	P33	O	Segment output terminal of P33.	70	11G	O	Grid output terminal of 11G.
31	P32	O	Segment output terminal of P32.	71	10G	O	Grid output terminal of 10G.
32	P31	O	Segment output terminal of P31.	72	9G	O	Grid output terminal of 9G.
33	P30	O	Segment output terminal of P30.	73	8G	O	Grid output terminal of 8G.
34	P29	O	Segment output terminal of P29.	74	7G	O	Grid output terminal of 7G.
35	P28	O	Segment output terminal of P28.	75	6G	O	Grid output terminal of 6G.
36	P27	O	Segment output terminal of P27.	76	5G	O	Grid output terminal of 5G.
37	P26	O	Segment output terminal of P26.	77	4G	O	Grid output terminal of 4G.
38	P25	O	Segment output terminal of P25.	78	3G	O	Grid output terminal of 3G.
39	P24	O	Segment output terminal of P24.	79	2G	O	Grid output terminal of 2G.
40	P23	O	Segment output terminal of P23.	80	1G	O	Grid output terminal of 1G.

ADJUSTMENT AND CONFIRMATION PROCEDURES 1

Idling current adjustment

Before Idling adjustment, turn the trimming resistors R6040, R6041, R6042, R6043 and R6044 to counter clockwise. Connect the DC voltmeter to sockets P6080, P6081, P6082, P6083, P6084 and P6085.

After turn POWER to ON, adjust the trimming resistors R6040, R6041 and R6042 so that the reading of voltmeter becomes 2.5 mV. (Front and center channels)

Adjust the trimming resistors R6043, R6044 and R6045 so that the reading of voltmeter becomes 1.5 mV. (Surround and surround back channels)

After adjustment, attach the top cover.

Confirm the voltage of points above after about five minutes.

Front and center channels

When less than 7.0 mV, readjust the resistors above so that the voltage becomes 7.0 mV.

When 7.0 mV to 9.0 mV, you are not necessary to adjust.

When more than 9.0 mV, readjust the resistors above so that the voltage becomes 9.0 mV.

Surround and surround back channels

When less than 4.0 mV, readjust the resistors above so that the voltage becomes 4.0 mV.

When 4.0 mV to 6.0 mV, you are not necessary to adjust.

When more than 6.0 mV, readjust the resistors above so that the voltage becomes 6.0 mV.

Note: No load and No signal

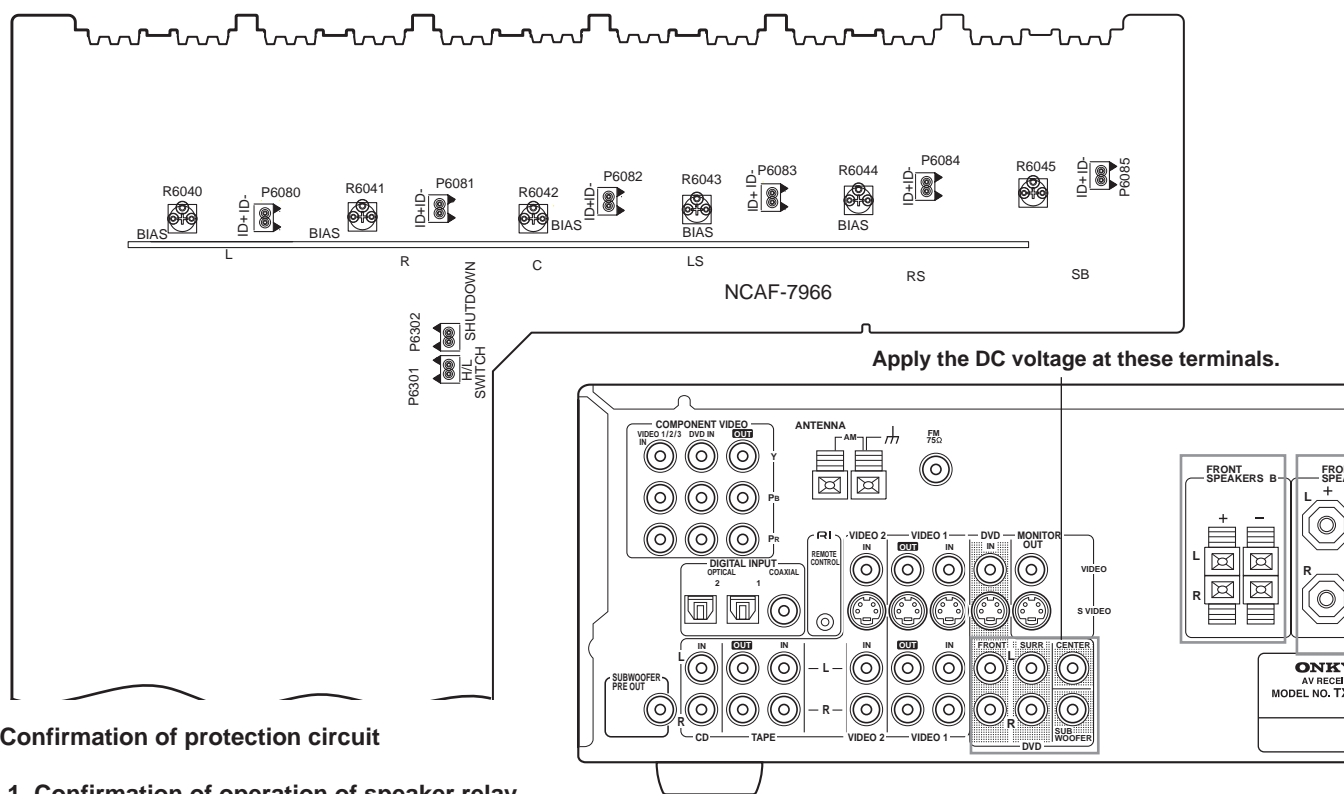

Confirmation of protection circuit

1. Confirmation of operation of speaker relay

Confirm that the speaker relays turn ON approximate. 5 seconds after the power switch is turned ON.

Confirm that the speaker relays turn OFF immediately after the power switch is turned OFF.

2. Confirmation of DC detection circuit

Press and hold down CD button, then press STANDBY/ON and DVD buttons to set the unit to "TEST-1" mode.

After "TEST-1" on the FL tube light on, press SPEAKER B button to set the unit to "TEST-1-00".

Apply DC 1.5 to 3V to DVD INPUT terminal with no load.

Confirm that the speaker relay turns OFF.

Apply DC -1.5 to -3V to DVD INPUT terminal with no load.

Confirm that the speaker relay turns OFF.

Caution: Don't apply DC voltage more than 1 sec..

Note: When surround back channel, confirm at "TEST-1-01".

ADJUSTMENT AND CONFIRMATION PROCEDURES 2

3. Confirmation of Current detection circuit

Set the unit to "TEST-1-00".

Connect the differentiating circuit and apply the 200Hz square signal to DVD INPUT terminal of each channel.

Adjust the attenuator or Volume so that the output level becomes 35V p-p.

Confirm that the speaker relay does not turn OFF when a 3.0 ohm load is connected.

Confirm that the speaker relay turn on when a 1.5 ohm load is connected.

Caution: Don't continue more than 3 seconds.

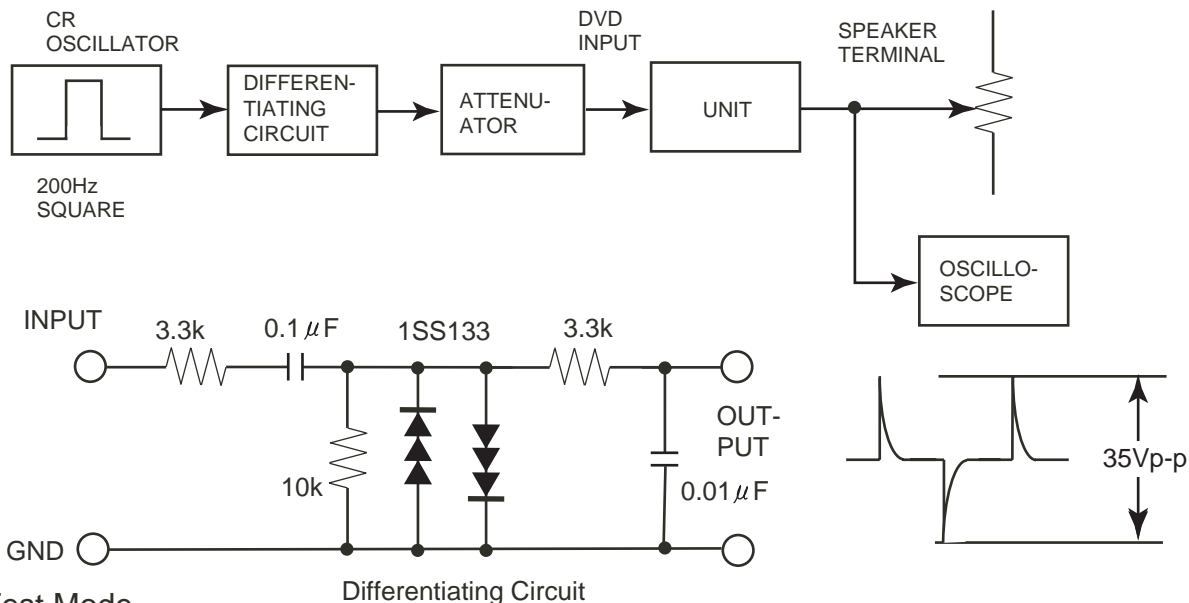

Test Mode

1. Turn POWER button on.
2. Press and hold down CD button, then press STANDBY/ON button.
3. After "TEST-" on the FL tube is displayed, press CD button to set the unit to the test mode of FL tube.

Note: DVD:TEST-1 VIDEO 1 :TEST-2 SP-B or SUBWOOFER MODE: UP
VIDEO 2 :TEST-3 VIDEO 3:TEST-4 SP-A or DIGITAL INPUT: DOWN

Test mode of FL tube

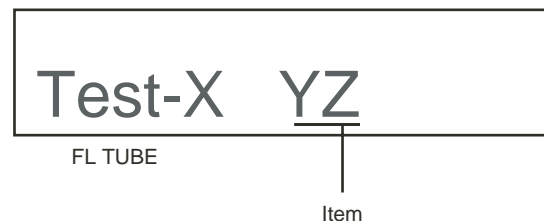
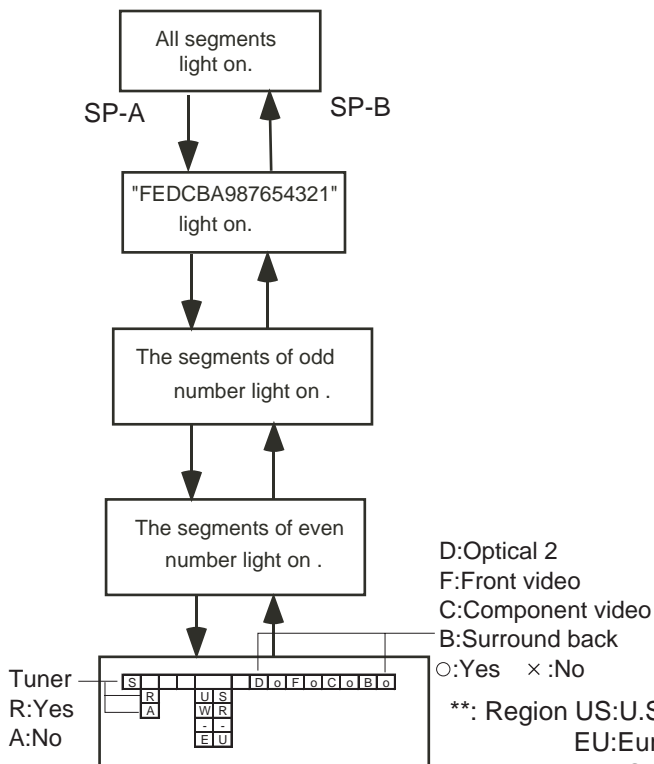

Confirmation of voltage sensor and thermal protect

1. Set the unit to TEST-3-03.
2. Apply the signal 1kHz, -15dBV to the DVD terminal input. Confirm that the FM STEREO on FL tube light on. Confirm the all channels except SUBWOFFER.
3. When connect the resistor 2.7 kohm/1 W between the terminals COM and TH1 of P6301, confirm that "MEMORY" light on.
Note: No input signal. Except 120V model.
4. When set the unit to "TEST-4-33, confirm that the speaker relays of RL6901 and RL6902 turn off.
Note: No input signal.

Press POWER button to finish the test mode of FL tube.

PACKING PROCEDURES

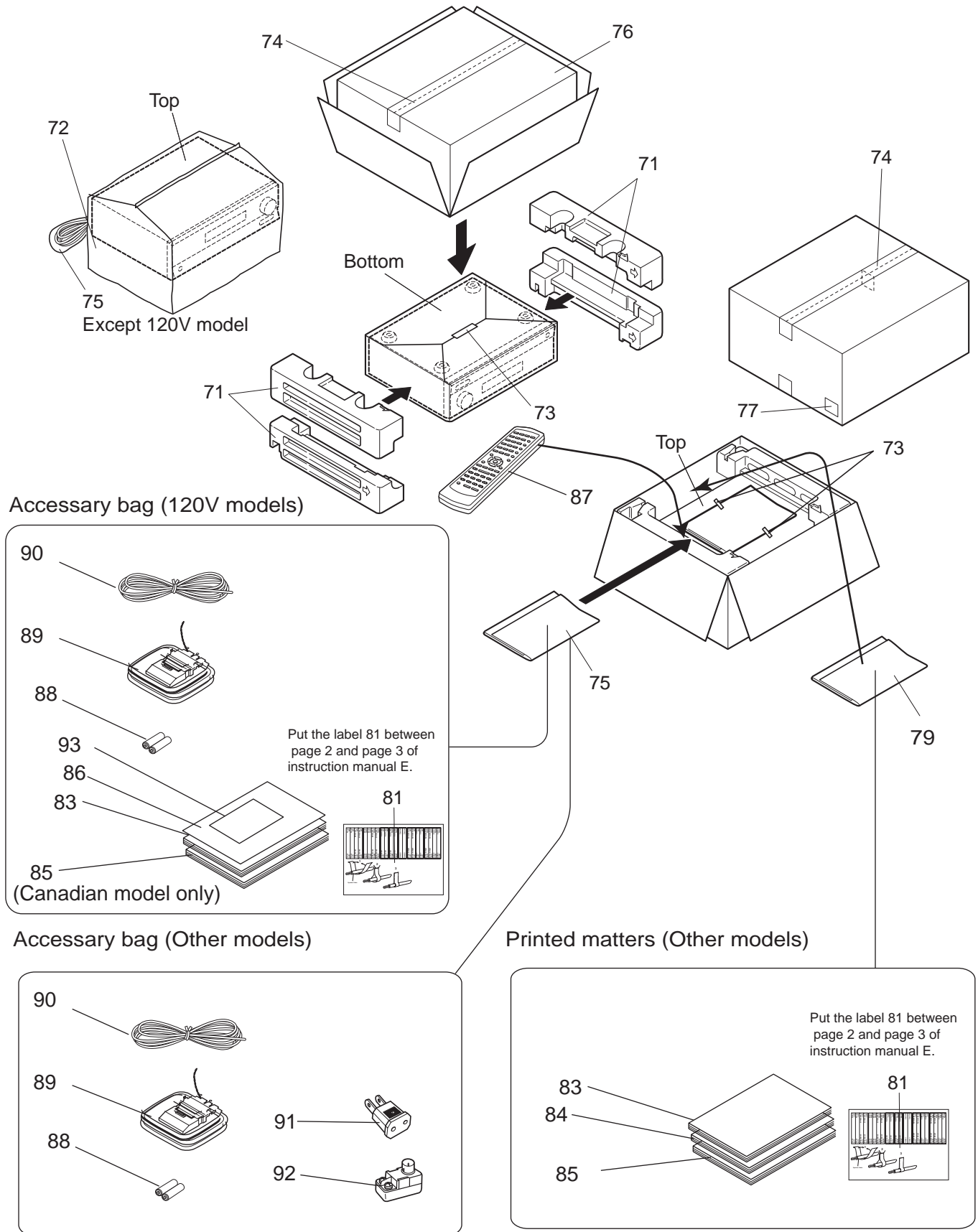

PRINTED CIRCUIT BOARD-PARTS LIST		
Display circuit PC board (NADIS-7403-2A/2B)		
CIRCUIT NO.	PART NO.	DESCRIPTION
	FL tube	
Q7501	212229	HNA-16MM39T
	Sensor	
U7501	241341	SPS-444-1-E1,Remote control
	IC	
Q7502	22241571R3	MPD780232GC-030-8BT
	Transistors	
Q7503	2216175R2 or	KTC3875-GR or
	2213145R2	2SC2712-GR
Q7504	2216230R2 or	KRA103S or
	2214540R2	RN2403
Q7506	2216190R2 or	KRC102S or
	2214470R2	RN1402
	Diodes	
D7501	224550820R2,	UDZS8.2B,
	224490820R2 or	UDZ8.2B or
	224660824R2	HZU8.2B,Zener
D7502	224550510R2,	UDZS5.1B,
	224490510R2 or	UDZ5.1B or
	224660514R2	HZU5.1B,Zener
D7503,D7507	223269R2 or	1SS355 or
	223234R2	1SS352
D7505	225290	SEL4110R,LED
	Choke coils	
L7504,L7505	231237K220R2	NCH-1477
	Oscillator	
X7501	3010242	CST5.00MGW,Ceramic
	Capacitors	
C7502	355783309	CE04W50V-33M,Elect.
C7514	394621017 or	CE04W6.3V-100M(VR) or
	394721017	CE04W6.3V100M(SC),Elect.
C7521	355722219	CE04W6.3V-220M,Elect.
	Rotary encoder	
S7501	25065627	EC12E2425
	Push switches	
S7611~S7613	25035718,	NPS-111-S681,
S7621~S7627	25035699 or	NPS-111-S662 or
S7631~S7637	25035714	NPS-111-S677
S7641~S7647	25035718,	NPS-111-S681,
	25035699 or	NPS-111-S662 or
	25035714	NPS-111-S677
	Sockets	
JL7501A	25051107	NSCT-3P894
JL7502A	25051109	NSCT-5P896
P7502A	25051892 or	NSCT-10P1679 or
	25052477	NSCT-10P2374
P7503A	25052054 or	NSCT-8P1841 or
	25051852	NSCT-8P1639
	Holder	
Q7501A	27190989A	(FL)
Standby switch PC board (NASW-7404-2A/2B)		
CIRCUIT NO.	PART NO.	DESCRIPTION
	Push switches	
S7614~S7616	25035718,	NPS-111-S681,
	25035699 or	NPS-111-S662 or
	25035714	NPS-111-S677
	Socket	
JL7501B	25051107	NSCT-3P894
Headphone terminal PC board (NAETC-7405-2A/2B)		
CIRCUIT NO.	PART NO.	DESCRIPTION
P7501	25045724	YKB21-5005,Headphone
JL7502B	25051109	NSCT-5P896,Socket
Front video PC board (NAETC-7406-2A/2B)		
CIRCUIT NO.	PART NO.	DESCRIPTION
P251	25045680	NPJ-7PDB477,Terminal
P253B	2009990578UL	NSAS-10P0787,Socket
P261B	2009990513UL	NSAS-6P0675,Socket

DSP circuit PC board (NADG-7821-1A/1B/1C/1D)		
CIRCUIT NO.	PART NO.	DESCRIPTION
	ICs	
Q181	22241297R2	BU1923F <P>
Q301	22241761R3	BD3811K1
Q302,Q305	22241383R2,	NJM4565M-D,
	22240489R1NE or	MPC4570G2-T1(MST) or
	22240581R2	NJM4565M
Q321	222780073R2	78L07(SMT)
Q322	222790073R2	79L07(SMT)
Q323	22241785R2	BD3812F
Q6402,Q6405	222780125	78M12HF
Q6403	222790125	79M12HF
Q6406	222780055	78M05HF
Q7002	22274541ER2TO or	TC74VHC541FT or
	22274541IR2TI	SN74AHC541PWR
Q7003	222740077R2TO	TC74HCT7007AF
Q7004	22241778R2	BA33C25FP
Q7008	22241970R3,	MPD784225GC-222-8BT,
	22241968R3 or	MPD784225GC-220-8BT or
	22241969R3	MPD784225GC-221-8BT
Q701	22241788R2	CS493292-CLR(6.1ch)
Q702	22241795R3	MX27L2000(TX-SR600)
Q704,Q705	22274574ER2TO or	TC74VHC574FT or
	22274574IR2TI	SN74AHC574PWR
Q707	22240935R2	TC7WU04FU
Q801	22241620R3	AK4586
Q802~Q804	22241383R2,	NJM4565M-D,
	22240489R1NE or	MPC4570G2-T1(MST) or
	22240581R2	NJM4565M
Q805	22241929R2	AK4384
	Transistors	
Q101	2216175R2 or	KTC3875-GR or
	2213145R2	2SC2712-GR <P>
Q306	2214530R2 or	RN2402 or
	2216220R2	KRA102S
Q307,Q308	2215410R2	RN1441
Q312,Q313	2215410R2	RN1441
Q7001	2214490R2 or	RN1404 or
	2216210R2	KRC104S
Q7006,Q7007	2214490R2 or	RN1404 or
	2216210R2	KRC104S
Q9501	2211455	2SA1015-GR
	Diodes	
D7001~D7004	223234R2 or	1SS352 or
D801,D802	223269R2	1SS355
D7702	224660624R2,	HZU6.2B,
	224490620R2 or	UDZ6.2B or
	224550620R2	UDZS6.2B,Zener
D9502~D9507	22380260,	RL1N4003,
D9509~D9512	22380032 or	1SR139-100 or
	22380035	GP104003E
D9508	224662704R2,	HZU27B,
	224492700R2 or	UDZ27B or
	224552700R2	UDZS27B,Zener
	Choke coils	
L181	231237K220R2 or	NCH-1477 or
	233533K220R2	NCH-1587-220K <P>
L7001,L703	231237K470R2 or	NCH-1479 or
	233533K470R2	NCH-1587-470K
L7002,L701	231237M022R2 or	NCH-1471 or
L702,L704	233533K022R2	NCH-1587-022K
L705,L706	230958R1	BK1608LM182-T
L801~L804	231237M022R2 or	NCH-1471 or
L806	233533K022R2	NCH-1587-022K
L805	230958R1	BK1608LM182-T
	Oscillators	
X181	3010321 or	HC-49/U034.332MHz or
	3010345	HQS-3H2-04332-20,Crystal <P>
X7001	3010361R2	CSTCE12M5G52-R0,Ceramic
X701	3010324R2	CSTCV12.2MTJ0C4,Ceramic

CIRCUIT NO.	PART NO.	DESCRIPTION
	Capacitors	
C101,C103	394780337 or 394680337	CE04W50V3.3M(SC) or CE04W50V-3.3M(VR),Elect.
C181	394780227 or 394680227	CE04W50V2.2M(SC) or CE04W50V-2.2M(VR),Elect. <P>
C184	354724709T	CE04W6.3V-47M,Elect. <P>
C300,C301	374721015 374724714	ECQ-B50V-101K,Plastic film <D> ECQ-B50V-471J,Plastic film <O>
C329~C334	393341007	CE04W16V-10M(VX),Elect.
C335,C336	373043324R2	ECHU16V-332J,Chip film
C338,C340	373045634R2	ECHU16V-563J,Chip film
C347,C348	394741017 or 394641017	CE04W16V100M(SC) or CE04W16V-100M(VR),Elect.
C349	393341007	CE04W16V-10M(VX),Elect.
C353,C354	393344707	CE04W16V-47M(VX),Elect.
C358	393344707	CE04W16V-47M(VX),Elect.
C359,C362	394741007 or 394641007	CE04W16V10M(SC) or CE04W16V-10M(VR),Elect.
C363,C364	393341007	CE04W16V-10M(VX),Elect.
C6401	374721044	ECQ-B50V-104J,Plastic film
C6404,C6406	394741007 or	CE04W16V10M(SC) or
C6410,C6412	394641007	CE04W16V-10M(VR),Elect.
C7001	3000078, 3000120 or 3000121	DX-5R5L104, FMC0H104Z or SCDA5R5104A,Super
C7002,C7005	394721017 or 394621017	CE04W6.3V100M(SC) or CE04W6.3V-100M(VR),Elect.
C7004	394780107 or 394680107	CE04W50V1.0M(SC) or CE04W50V-1M(VR),Elect.
C7011,C7012	394744707 or	CE04W16V47M(SC) or
C7015	394644707	CE04W16V-47M(VR),Elect.
C706,C716	394721017 or 394621017	CE04W6.3V100M(SC) or CE04W6.3V-100M(VR),Elect.
C801,C810	394744707 or 394644707	CE04W16V47M(SC) or CE04W16V-47M(VR),Elect.
C806	394724717 or 394624717	CE04W6.3V470M(SC) or CE04W6.3V-470M(VR),Elect.
C809,C820	394741007 or 394641007	CE04W16V10M(SC) or CE04W16V-10M(VR),Elect.
C810	394744707 or 394644707	CE04W16V47M(SC) or CE04W16V-47M(VR),Elect.
C822	394722217 or 394622217	CE04W6.3V220M(SC) or CE04W6.3V-220M(VR),Elect.
C832~C837	393341007	CE04W16V-10M(VX),Elect.
C841	373048224R2	ECHU16V-822J,Chip film
C849	373041534R2	ECHU16V-153J,Chip film
C852,C853	374721524	ECQ-B50V-152J,Plastic film
C854	393341007	CE04W16V-10M(VX),Elect.
C855	393344707	CE04W16V-47M(VX),Elect.
C856~C860	393341007	CE04W16V-10M(VX),Elect.
C863	393341007	CE04W16V-10M(VX),Elect.
C9501~C9503	374721044	ECQ-B50V-104J,Plastic film
C9505	394762227 or 394662227	CE04W35V2200M(SC) or CE04W35V-2200M(VR),Elect.
C9506	394764717 or 394664717	CE04W35V470M(SC) or CE04W35V-470M(VR),Elect.
C9507	394762217 or 394662217	CE04W35V220M(SC) or CE04W35V-220M(VR),Elect.
C9508	394744727 or 394644727	CE04W16V4700M(SC) or CE04W16V-4700M(VR),Elect.
C9510	394672217	CE04W63V-220M(VR),Elect.
	Resistors	
R6402	442521004	RS1/2WBJ-10,Metal oxide
R6403	442523304	RS1/2WBJ-33,Metal oxide
R6407	452630334	RNU1WCJ-3.3,Metal
R6410	453530224	RNU1/2WCJ-2.2,Metal
R9506	443522204	RS1/2WBJ-22,Metal oxide
	Terminals	
P301,P304	25045571 or 25045300	NPJ-6PDRW386 or NPJ-6PDBL159
P305	25045697	NPJ-6PWRLGGP493
P351	25045720	NPJ-1PDP510

CIRCUIT NO.	PART NO.		DESCRIPTION
	Sockets		
P101	25052211 or		NSCT-15P2108 or
	25052024		NSCT-15P1811
P306	2009990825UL		NSAS-26P1207
P7502B	25052576R2		NSCT-10P2473
	Plugs		
P261A	25055133		NPLG-3P117
P410B	25055707		NPLG-11P663
P411B	25055706		NPLG-10P662
P412B	25055704		NPLG-8P660
P801	25055711		NPLG-15P667
	Heat sink		
Q6402B	27160526		RAD-183
	Screws		
Q6402A,Q6405A	82143010		3P+10FN(BC),Pan head
Q6406A	82143010		3P+10FN(BC),Pan head
Driver circuit PC board (NAAF-7830-1A/1B)			
CIRCUIT NO.	PART NO.		DESCRIPTION
	Transistors		
Q5000~Q5005	2215896,	*	KTC3200-BL,
Q5010~Q5015	2210755,	*	2SC1775A-E,
	2210756 or	*	2SC1775A-F or
	2211733	*	2SC1845-E
Q5030~Q5035	2215844,		KTA1024-Y,
	2211353,		2SA949-O,
	2211354 or		2SA949-Y or
	2215843		KTA1024-O
Q5040~Q5045	2215854,		KTC3206-Y,
	2211633,		2SC2229-O,
	2211634 or		2SC2229-Y or
	2215853		KTC3206-O
Q5050~Q5055	2215864,		KTC3199-GR,
	2212115,		2SC2458-GR,
	2213284 or		2SC1740S-R or
	2213285		2SC1740S-S
	Diodes		
D5000~D5005	224470562		MTZJ5.6B
	Capacitors		
C5000~C5005	374721015		ECQ-B50V-101K,Plastic film
C5010~C5015	393342207		CE04W16V-22M(VX),Elect.
C5020~C5025	394681007		CE04W50V-10M(VR),Elect.
C5040,C5041	393342217		CE04W16V-220M(VX),Elect.
C5042~C5045	393342217		CE04W16V-220M(VX),Elect.
C5050~C5055	394684707		CE04W50V-47M(VR),Elect.
C5100~C5105	394671007		CE04W63V-10M(VR),Elect.
C5110~C5115	394671007		CE04W63V-10M(VR),Elect.
	Resistors		
R5160~R5165	415471214		R25J-120,NF carbon
R5170~R5175	415471214		R25J-120,NF carbon
R5180~R5185	415471004		R25J-10,NF carbon
R5190~R5195	415471004		R25J-10,NF carbon
	Sockets		
P6000A~P6005A	25052288		NSCT-5P2185
P6011A	25052293		NSCT-10P2190
	Plug		
P306A	25055376		NPLG-12P359
	Bus bar		
P5001	27141867		BBL40
Component video PC board (NAVD-7831-1A/1B)			
CIRCUIT NO.	PART NO.		DESCRIPTION
	Transistor		
Q241	2215864,		KTC3199-GR,
	2212115,		2SC2458-GR,
	2213284 or		2SC1740S-R or
	2213285		2SC1740S-S
	Diode		
D241	223163 or		1SS133 or
	223205		1SS270A
	Relays		
RL241,RL242	25065610		NRL-2P1A-DC4.5-156

CIRCUIT NO.	PART NO.	DESCRIPTION
	Terminal	
P241	25045731	NPJ-9PDGLR519
	Sockets	
P242A	25052216	NSCT-20P2113
P243B	25051526	NSCT-4P1313
Constant voltage circuit PC board (NAETC-7833-1A/1B)		
CIRCUIT NO.	PART NO.	DESCRIPTION
	IC	
Q6931	222780565JRC	78M56(NJM78M56FA)
	Diodes	
D6932,D6933	22380260 or	RL1N4003 or
D6932 or	22380035	GP104003E
	Capacitors	
C6931	394651027 or	CE04W25V-1000M(VR) or
	394751027S	CE04W25V1000M(SC),Elect.
C6933	394641007 or	CE04W16V-10M(VR) or
	394741007	CE04W16V10M(SC),Elect.
	Resistor	
R6935	441721214	RS2WBJ-120,Metal oxide
	Sockets	
JL9501A	25051111	NSCT-7P898
P410A	25051236	NSCT-11P1026
P411A	25051235	NSCT-10P1025
P6931A	25051527	NSCT-16P1314
P7503B	25052241,	NSCT-8P2138,
	25051312,	NSCT-8P1101,
	25051852 or	NSCT-8P1639 or
	25052054	NSCT-8P1841
Secondary circuit PC board (NAPS-7834-1A/1B)		
CIRCUIT NO.	PART NO.	DESCRIPTION
	Resistors	
R9501	453530104	RNU1/2WCJ-1,Metal
R9502	453534794	RNU1/2WCJ-0.47,Metal
R9503	453532294	RNU1/2WCJ-0.22,Metal
R9521	453530394	RNU1/2WCJ-3.9,Metal <D>
	453530334	RNU1/2WCJ-3.3,Metal <O>
	Socket	
JL9501B	25051111	NSCT-7P898
Speaker terminal PC board ass'y (NAETC-7835-1A/1B)		
CIRCUIT NO.	PART NO.	DESCRIPTION
	Diodes	
D6600,D6601	223163,	1SS133,
D6604	223205 or	1SS270A or
	223222	WG713A
	Coils	
L6800~L6805	231176S	S-1.3C <O>
	Capacitors	
C6600,C6604	374721034	ECQ-B50V-103J,Plastic film
C6840~C6845	374722224	ECQ-B50V-222J,Plastic film <O>
	Relays	
RL6600,RL6601	25065563,	NRL-2P5A-DC24-129,
RL6603,RL6604	25065517 or	NRL-2P5A-DC24-098 or
	25065586	NRL-2P5A-DC24-142
	Terminals	
P6800	25060347	NTM-4PDMN278 <D>
P6800	25060316	NTM-4PDMN247 <O>
P6801	25060317	NTM-4PDMN248
P6802	25060348	NTM-8PDMN279 <D>
P6802	25060349	NTM-8PDMN280 <O>
	Sockets	
JL6803B~JL6805B	25050270	NSCT-6P98
Connector PC board (NAETC-7838-1A/1B)		
CIRCUIT NO.	PART NO.	DESCRIPTION
P206A	25055711	NPLG-15P667,Plug
P243A	25055804	NPLG-4P760,Plug
P801B	25051240	NSCT-15P1030,Socket

Power amplifier PC board (NAAF-7842-1A/1B/1C/1D/1E/1F)		
CIRCUIT NO.	PART NO.	DESCRIPTION
	Transistors	
Q6010~Q6015	2213284 or 2213285	2SC1740S-R or 2SC1740S-S
Q6020~Q6025	2213284 or 2213285	2SC1740S-R or 2SC1740S-S
Q6030~Q6035	2203434 or 2203010	KTD2061-Y or 2SC5171
Q6040~Q6045	2203424 or 2203000	KTB1369-Y or 2SA1930
Q6070~Q6075	2215896, 2210755, 2210756, 2211732, 2211733 or 2215895	KTC3200-BL, 2SC1775A-E, 2SC1775A-F, 2SC1845-F, 2SC1845-E or KTC3200-GR
Q6303	2215995, 2213354 or 2213355	KTA1267-GR, 2SA933S-R or 2SA933S-S
Q6313	2215995, 2213354 or 2213355	KTA1267-GR, 2SA933S-R or 2SA933S-S <O>
Q6601~Q6603	2215864, 2212115, 2213284 or 2213285	KTC3199-GR, 2SC2458-GR, 2SC1740S-R or 2SC1740S-S
Q6701,Q6702	2215896, 2210755, 2210756, 2211732, 2211733 or 2215895	KTC3200-BL, 2SC1775A-E, 2SC1775A-F, 2SC1845-F, 2SC1845-E or KTC3200-GR
Q6703	2215885, 2211792, 2211793 or 2215886	KTA1268-GR, 2SA992-F, 2SA992-E or KTA1268-BL
Q6901	2215864, 2212115, 2213284 or 2213285	KTC3199-GR, 2SC2458-GR, 2SC1740S-R or 2SC1740S-S
Q921	2215864, 2212115, 2213284 or 2213285	KTC3199-GR, 2SC2458-GR, 2SC1740S-R or 2SC1740S-S
	Diodes	
D6000~D6005	223163,	1SS133,
D6010~D6015	223205 or	1SS270A or
D6306,D6307	223222	WG713A
D6701,D6702	223163,	1SS133,
D6906	223205 or 223222	1SS270A or WG713A
D6703,D6704	224470512	MTZJ5.1B
D6714	224470512	MTZJ5.1B <O>
D6903,D6904	22380130, 22380038 or 22380274	D5SBA20, RBV602 or RS603M-B42
	Capacitors	
C6040~C6045	394684707	CE04W50V-47M(VR),Elect.
C6050~C6055	374722234	ECQ-B50V-223J,Plastic film
C6230~C6235	374724734	ECQ-V50V-473J,Plastic film
C6701,C6706	394621017 or 394721017	CE04W6.3V-100M(VR) or CE04W6.3V100M(SC),Elect.
C6704	394680107 or 394780107	CE04W50V-1M(VR) or CE04W50V1.0M(SC),Elect.
C6708	374722234	ECQ-B50V-223J,Plastic film
C6716	394621017	CE04W6.3V-100M(VR),Elect. <O>
C6901	3504351	CE69W56V10000M,Elect.
C6902	3504351	CE69W56V10000M,Elect.
C6903	374721044	ECQ-B50V-104J,Plastic film
C6904,C6905	374723344	ECQ-V50V-334J,Plastic film
C6906,C6907	374721044	ECQ-B50V-104J,Plastic film

CIRCUIT NO.	PART NO.		DESCRIPTION
	Resistors		
R6040~R6045	5210258		N06HR1KBC,Trimming
R6070~R6075	415471014		R25J-100,NF carbon
R6080~R6085	415470224		R25J-2.2,NF carbon
R6090~R6095	415470224		R25J-2.2,NF carbon
R6100~R6105	4800071,		RSS2WK-0.22,
	4000131 or		RGC22-0.22 OHMK or
	4500027		MPC708-2WK-0.22,Metal plate
R6230~R6235	453630824		RNU1WCJ-8.2,Metal
R6604,R6605	453530824		RNU1/2WCJ-8.2,Metal
R6850,R6851	443523914		RS1/2WBJ-390,Metal oxide
	Relays		
RL6901,RL6902	25065561,		NRL-1P5A-DC12-127,
	25065508,		NRL-1P10A-DC12-093,
	25065515 or		NRL-1P5A-DC12-096 or
	25065526		NRL-1P5A-DC12-102
	Fuse holders		
F6901A,F6901B	25052133	!	NSCT-1P2031
F6902A,F6902B	25052133	!	NSCT-1P2031
	Sockets		
JL6402A	25051087		NSCT-3P874
JL6803A,JL6804A	25051110		NSCT-6P897
JL6805A	25051108		NSCT-4P895
JL6951A,JL6952A	25051109		NSCT-5P896
	Plugs		
P6000~P6005	25056010		NPLG-5P0960
P6011	25056015		NPLG-10P0965
P6080~P6085	25055038		NPLG-2P29
P6301	25055042		NPLG-3P32
P6931	25055805		NPLG-16P761
P931	25055701		NPLG-5P657
	Bar		
C6901A	27141817		(BUS)
	Label		
F6901C	29362800		T8AL250V,Fuse <O>
Power switch PC board (NASW-7843-1B/1D/1E/1F)			
CIRCUIT NO.	PART NO.		DESCRIPTION
S906	25035702	!	NPS-121-L665P,Switch <P/T/R/Q/K>
Primary circuit PC board (NAPS-7845-1A/1B/1C/1D/1E/1F)			
CIRCUIT NO.	PART NO.		DESCRIPTION
	Power transformer		
T902	2301381	!	NPT-1358D <D>
T902	2301382	!	NPT-1358P <P/A>
T902	2301383	!	NPT-1358DG <T/R/Q/K>
	Diodes		
D921~D924	22380260 or		RL1N4003 or
	22380035		GP104003E
D925	223163,		1SS133,
	223205 or		1SS270A or
	223222		WG713A
	Capacitors		
C901	3500196S	!	RE275V-103M,IS
C902	3300030	!	DE1307E472M-KH,IS <O>
C922	394662217		CE04W35V-220M(VR),Elect.
	Resistors		
R901	4000206 or	!	RD1/2SPH-3.3M or
	431533355	!	RC1/2GFKUL-3.3M, Solid <D>
R924	443528204		RS1/2WBJ-82,Metal oxide
	Relay		
RL901	25065561,	!	NRL-1P5A-DC12-127,
	25065508,	!	NRL-1P10A-DC12-093,
	25065515 or	!	NRL-1P5A-DC12-096 or
	25065526	!	NRL-1P5A-DC12-102
	Switch		
S902	25065437	!	NSS-22157P,Voltage <T/R/Q>
	Fuse holders		
F901A,F901B	25052133	!	NSCT-1P2031 <D/T/R/Q>
F902A,F902B	25052133	!	NSCT-1P2031 <O>
F903A,F903B	25052133	!	NSCT-1P2031 <O>

CIRCUIT NO.	PART NO.		DESCRIPTION
	Sockets		
P902	25051571	!	NSCT-2P1358 <D>
P902	25051572	!	NSCT-2P1359 <P/T/Q>
P902	25052115	!	NSCT-2P2013 <A>
P902	25052664	!	NSCT-2P2560 <R>
P931A	25051230		NSCT-5P1020
	Plug		
P901A	25055675 or	!	NPLG-2P631 or
	25056028	!	NPLG-2P0978
Secondary terminal PC board (NAPS-7846-1A/1B/1C/1D/1E/1F)			
CIRCUIT NO.	PART NO.		DESCRIPTION
JL6951B,JL6952B	25051109		NSCT-5P896,Wire holder
Video circuit PC board (NAVD-7847-1A/1B/1C/1D/1E/1F)			
CIRCUIT NO.	PART NO.		DESCRIPTION
	ICs		
Q203	22241759		LA7956
Q212,Q213	22241759		LA7956
Q281	222740046R2		74HCU04F
	Photo couplers		
U281,U282	24120101		TORX179L
	Transistors		
Q201,Q202	2213631 or		RN1241-A or
Q207,Q208	2213632		RN1241-B
Q204,Q209	2215995 or		KTA1267-GR or
	2213354		2SA933S-R
Q205,Q206	2215770 or		KRA102M or
	2213510		DTA114ES
Q210,Q211	2213631 or		RN1241-A or
	2213632		RN1241-B
	Coils		
L281,L282	233454K220 or		NCH-1452 220K or
	233526K220		NCH-1561 220K
L283	233454M022 or		NCH-1452 022M or
	233526K022		NCH-1561 022K
	Capacitors		
C201,C202	394680227 or		CE04W50V-2.2M(VR) or
C204,C207	394780227		CE04W50V2.2M(SC),Elect.
C203,C205	394644717 or		CE04W16V-470M(VR) or
C211,C215	394744717		CE04W16V470M(SC),Elect.
C209,C213	394680227 or		CE04W50V-2.2M(VR) or
C217,C218	394780227		CE04W50V2.2M(SC),Elect.
C221,C223	394644707 or		CE04W16V-47M(VR) or
C225	394744707		CE04W16V47M(SC),Elect.
C285	394624707 or		CE04W6.3V-47M(VR) or
	394624707		CE04W6.3V-47M(VR),Elect.
	Terminals		
P201	25045729		NPJ-10PDBY517
P202	25045727		NPJ-15PDBY515
P281	25045473		NPJ-1PDBL291
P282	25045696		LGY2502-0200C
	Socket		
P206B	25051240		NSCT-15P1030
	Plug		
P253A	25055236		NPLG-5P220
Thermal detector PC board (NAETC-7849-1A/1B/1C/1D/1E/1F)			
CIRCUIT NO.	PART NO.		DESCRIPTION
R6380	4000153		PTH9M04BF222TS2F333,Thermistor
JL6402B	25051087		NSCT-3P874,Socket
R6381	4000150		PTH9M04BC222TS2F333,Thermistor <O>
<D>:120V model only			NOTE: THE COMPONENTS IDENTIFIED BY MARK !
<P>:European model only			ARE CRITICAL FOR RISK OF FIRE AND
<T>:Worldwide model only			ELECTRIC SHOCK. REPLACE ONLY WITH
<A>:Australian model only			PART NUMBER SPECIFIED.
<R>:Chinese model only			
<K>:Korean model only			CAUTION: Replacement for transistor of mark *, if necessar
<Q>:Hong Kong model only			must be made from the same beta group (hFE) as
<O>:Except 120V model			the original type.

EXPLODED VIEW-PARTS LIST		
REF.NO.	PART NO.	DESCRIPTION
1	27111268	Front bracket
	27111269	Front bracket <S>
	27111270	Front bracket <G>
2	838130088	3TTB+8B,Self-tapping screw
3	82143010	3P+10FN(BC),Pan head screw
4	28325497A	Knob,power
	28325499A	Knob,power <G>
	28325547A	Knob,power <S>
5	27100416A	Chassis
6	27190503A	KGLS-8RT,Holder
7	27190813	KGPS-10RF,Holder
8	27190428A	KGLS-10RT,Holder
9	830440089	4TTC+8C(BC),Self-tapping screw
10	880009	NRP-345,Plastic rivet
11	27300750	! Cord, bushing
12	27160527	Heatsink
13	801606	3SMH10W.SW+15B(CU),Special screw
16	28184831	Top cover
	28184856	Top cover <S>
	28184857	Top cover <G>
17	838430088	3TTB+8B(BC),Self-tapping screw
	838930088	3TTB+8B(UN),Self-tapping screw <S/G>
18	29363194	Label,hookup <D>
21	27175319B	Leg
22	28141494	Cushion
23	838130088	3TTB+8B,Self-tapping screw
24	28325641	Knob volume
	28325642	Knob volume <S>
	28325643	Knob volume <G>
25	28191957	Clear plate
	28191958	Clear plate <G/S>
31	27123068A	Rear panel <D>
	27123069A	Rear panel <P>
	27123070A	Rear panel <K>
	27123071A	Rear panel <T/Q>
	27123072A	Rear panel <R>
	27123073A	Rear panel <A>
32	27191143	Holder, outlet <R>
33	838430088	3TTB+8B(BC),Self-tapping screw
51	27212471	Front panel <D>
	27212472	Front panel <S><A/R>
	27212473	Front panel <P>
	27212474	Front panel <S><P>
	27212475	Front panel <A/T>
	27212476	Front panel <G>
	27212534	Front panel <S><C>
52	28135244	Badge
	28135245	Badge <S/G>
53	838430088	3TTB+8B(BC),Self-tapping screw
54	29110083	Tape, cloth
55	223024	AC238,Isolated sheet
56	260208	Wire tie
63	29363379-1	Label PT
F6901,F6902	252198 or	! 8A-UL or
	252261	! 8A-T/UL-ST2 <D>
	252099	! 8A-EAK ,Fuse <O>
F901	252166 or	! 6.3A-UL/T-237 or
	252260	! 6.3A-T/UL-ST2,Fuse <D/T/Q/R>
F902	252076,	! 3.15A-SE-EAK,
	252242 or	! 3.15A-SE-TL250V or
	252276	! 3.15A-SE-TL250V <O>
F903	252075,	! 2.5A-SE-EAK,
	252241 or	! 2.5A-SE-TL250V or
	252275	! 2.5A-SE-TL250V,Fuse <O>
P101	2047151512	NCFC7-151512,Flexible cable
P7502	2045102012	NCFC5-102012,Flexible cable

REF.NO.	PART NO.	DESCRIPTION
P7503	2047081012	NCFC7-081012,Flexible cable
P901	253332HIT or	! AS-UC-2 or
	253333VOL	! AS-UC-2,Power supply cord <D>
	253197HIT	! AS-SAA,Power supply cord <A>
	253233KAW or	! AS-CEE-2 or
	253198HIT	! AS-BS,Power supply cord <Q>
	253355VOL	! AS-CCC,Power supply cord <R>
	253306VOL	! AS-CEE-2,Power supply cord <P/T/K>
P902A	25052665	! NSCT-2P2561,AC outlet <K>
Q6050~Q6055	2203062,	* 2SC5198-R,
	2203063,	* 2SC5198-O,
	2203663,	* MN130S-O,
	2203664 or	* MN130S-Y or
	2203666	* MN130S-P,Transistor
Q6060~Q6065	2203052,	* 2SA1941-R,
	2203053,	* 2SA1941-O,
	2203673,	* MP130S-O,
	2203674 or	* MP130S-Y or
	2203676	* MP130S-P,Transistor
T901	2301676	! NPT-1462D,Power transformer <D>
	2301677	! NPT-1462P,Power transformer <P/A>
	2301678	! NPT-1462DG,Power transformer <T/Q/R/K>
U1	1A970521-1A	NADG-7821-1A,DSP circuit PC board ass'y <D>
	1A970521-1B	NADG-7821-1B,DSP circuit PC board ass'y <P>
	1A970521-1C	NADG-7821-1C,DSP circuit PC board ass'y <A/K>
	1A970521-1D	NADG-7821-1D,DSP circuit PC board ass'y <T/Q/R>
U3	1A970503-2A	NADIS-7403-2A,Display circuit PC board ass'y <D>
	1A970503-2B	NADIS-7403-2B,Display circuit PC board ass'y <O>
U4	1A970504-2A	NASW-7404-2A,Standby switch PC board ass'y <D>
	1A970504-2B	NASW-7404-2B,Standby switch PC board ass'y <O>
U5	1A970505-2A	NAETC-7405-2A,Headphone terminal PC board ass'y
	1A970505-2B	NAETC-7405-2B,Headphone terminal PC board ass'y
U6	1A970506-2A	NAETC-7406-2A,Front video PC board ass'y <D>
	1A970506-2B	NAETC-7406-2B,Front video PC board ass'y <O>
U9	1A970530-1A	NAAF-7830-1A,Driver circuit PC board ass'y <D>
	1A970530-1B	NAAF-7830-1B,Driver circuit PC board ass'y <O>
U10	1A970531-1A	NAVD-7831-1A,Component video PC board ass'y <D>
	1A970531-1B	NAVD-7831-1B,Component video PC board ass'y <O>
U12	1A970533-1A	NAETC-7833-1A,Const. Voltage circuit PC board ass'y
	1A970533-1B	NAETC-7833-1B,Const. Voltage circuit PC board ass'y
U13	1A970534-1A	NAPS-7834-1A,Secondary circuit PC board ass'y <D>
	1A970534-1B	NAPS-7834-1B,Secondary circuit PC board ass'y <O>
U14	1A970535-1A	NAETC-7835-1A,Speaker terminal PC board ass'y <D>
	1A970535-1B	NAETC-7835-1B,Speaker terminal PC board ass'y <O>
U15	1A970536-1A	NAETC-7836-1A,Ground terminal PC board ass'y <D>
	1A970536-1B	NAETC-7836-1B,Ground terminal PC board ass'y <O>
U17	1A970538-1A	NAETC-7838-1A,Connector PC board ass'y <D>
	1A970538-1B	NAETC-7838-1B,Connector PC board ass'y <O>
U21	1A970542-1A	NAAF-7842-1A,Power amplifier PC board ass'y <D>
	1A970542-1B	NAAF-7842-1B,Power amplifier PC board ass'y <P>
	1A970542-1C	NAAF-7842-1C,Power amplifier PC board ass'y <A>
	1A970542-1D	NAAF-7842-1D,Power amplifier PC board ass'y <R>
	1A970542-1E	NAAF-7842-1E,Power amplifier PC board ass'y <T/Q>
	1A970542-1F	NAAF-7842-1F,Power amplifier PC board ass'y <K>
U22	1A970543-1B	NASW-7843-1B,Power switch PC board ass'y <P>
	1A970543-1D	NASW-7843-1D,Power switch PC board ass'y <R>
	1A970543-1E	NASW-7843-1E,Power switch PC board ass'y <T/Q>
	1A970543-1F	NASW-7843-1F,Power switch PC board ass'y <K>
U23	1A970544-1A	NAPS-7844-1A,Transformer terminal PC board ass'y <D>
	1A970544-1B	NAPS-7844-1B,Transformer terminal PC board ass'y <P>
	1A970544-1C	NAPS-7844-1C,Transformer terminal PC board ass'y <A>
	1A970544-1D	NAPS-7844-1D,Transformer terminal PC board ass'y <R>
	1A970544-1E	NAPS-7844-1E,Transformer terminal PC board ass'y
	1A970544-1F	NAPS-7844-1F,Transformer terminal PC board ass'y <K>

PACKING-PARTS LIST		
REF.NO.	PART NO.	DESCRIPTION
71	29092044	Pad
72	29100034-1A	850*650,Polybag
73	29110149	Tape, cellophane
74	29110148	PP tape
75	29100201	350*200*W250,Polybag
76	29054007	Carton box <D>
	29054008	Carton box <A/R/C>
	29054009	Carton box <P>
	29054010	Carton box <S> <P>
	29054011	Carton box <G>
	29054012	Carton box <A/T/C>
77	29363320	Label EAN <P>
	29363321	Label EAN <S> <P>
	29363322	Label EAN <T/A>
	29363323	Label EAN <S> <A/R>
	29363324	Label EAN <G>
	29363325	Label UPC <D/C>
	29363496	Label UPC <S> <C>
79	29100097-1A	350*250,Polybag for power cord <O>
81	29363059A	Label,cable
83	29343474A	Instruction manual E
84	29343476A	Instruction manual U3GDSW <P>
	29343478	Instruction manual U2CTCS <T/Q/R>
85	29343477A	Instruction manual U3FSI <P/C>
86	29343475	Instruction manual, digest <D>
87	24140479	RC-479S,Remote controller <O>
	24140518	RC-518M,Remote controller <D>
88	3010054	R6/AA(UM-3),Two batteries
89	232140	NMA-3057,AM loop antenna
90	292191	FM antenna
91	25065462	YAE21-0237,Antenna adapter <T/A/R/Q/K>
92	25056005	CV-K-1,Conversion plug <T>
93	29365090A	Warranty card <D>
		:Black model only
		<S>:Silver model only
		<G>:Golden model only
		<D>:120V model only
		<P>:European model only
		<T>:Worldwide model only
		<A>:Australian model only
		<R>:Chinese model only
		<C>:Canadian model only
		<K>:Korean model only
		<Q>:Hongkong model only
		<O>:Except 120V model

ONKYO CORPORATION

Sales & Product Planning Div. : 2-1, Nisshin-cho, Neyagawa-shi, OSAKA 572-8540, JAPAN
Tel: 072-831-8111 Fax: 072-833-5222

ONKYO U.S.A. CORPORATION

18 Park Way, Upper Saddle River, N.J. 07458, U.S.A.
Tel: 201-785-2600 Fax: 201-785-2650 E-mail: onkyo@onkyousa.com

ONKYO EUROPE ELECTRONICS GmbH

Liegnitzerstrasse 6, 82194 Groebenzell, GERMANY
Tel: +49-8142-4401-0 Fax: +49-8142-4401-555 E-mail: info@onkyo.de

ONKYO CHINA LIMITED

Units 2102-2107, Metroplaza Tower I, 223 Hing Fong Road, Kwai Chung,
N.T., HONG KONG Tel: 852-2429-3118 Fax: 852-2428-9039

