

# BLOCK DIAGRAMS-1 AUDIO SECTION

<http://receiverfaq.ru/>

1

2

3

4

5

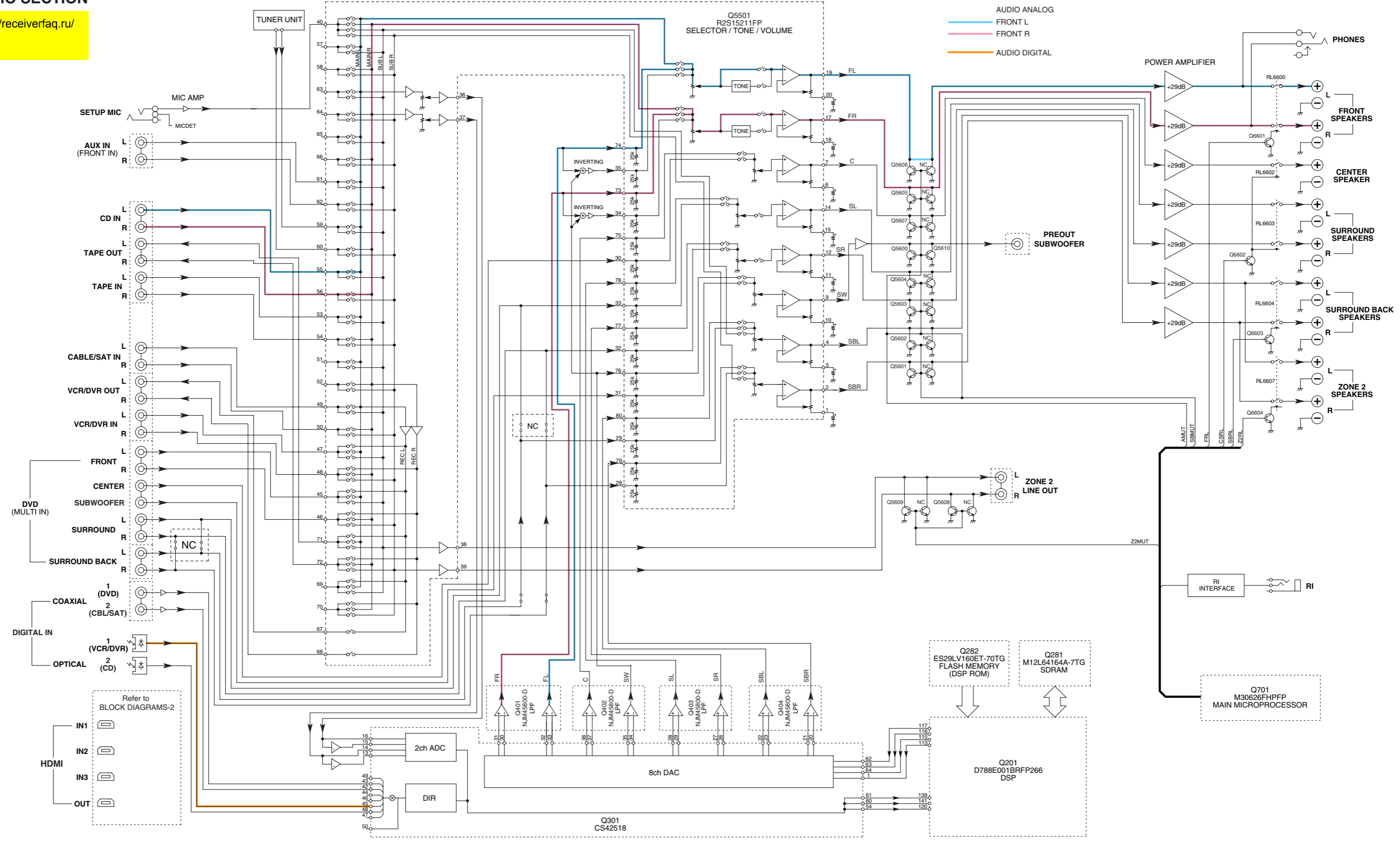

**BLOCK DIAGRAMS-2**  
**VIDEO / HDMI SECTION**

1  
2  
3  
4  
5

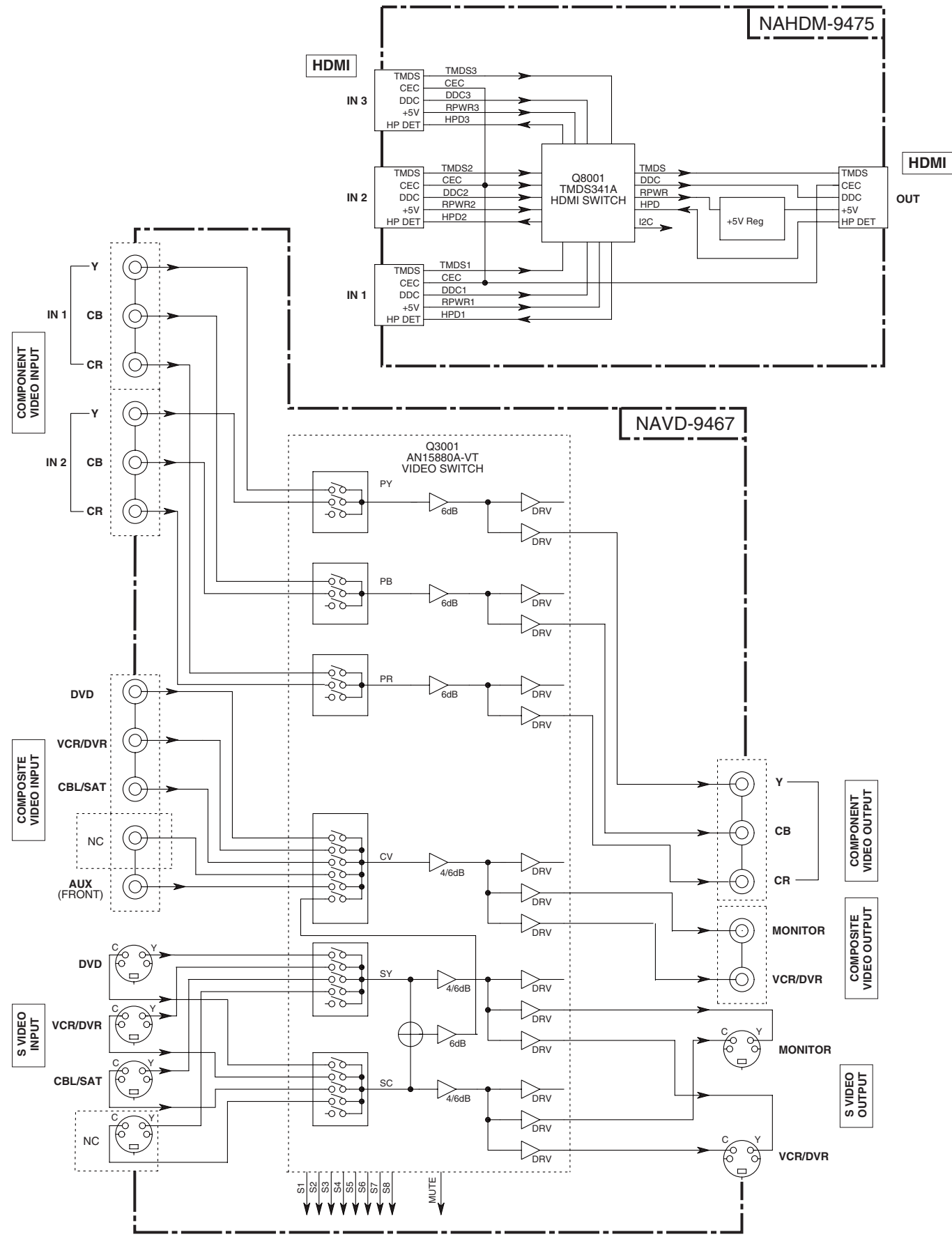

**SCHEMATIC DIAGRAMS-1 (SD-1)**  
**AUDIO INPUT SECTION**

<Note>  
1. NC = No mount of parts.  
2. SD-x : XY is short for Schematic Diagrams-x and each sockets location, X = A to H, Y = 1 to 5.

AUDIO ANALOG SIGNAL  
FRONT L  
FRONT R

1  
2  
3  
4  
5

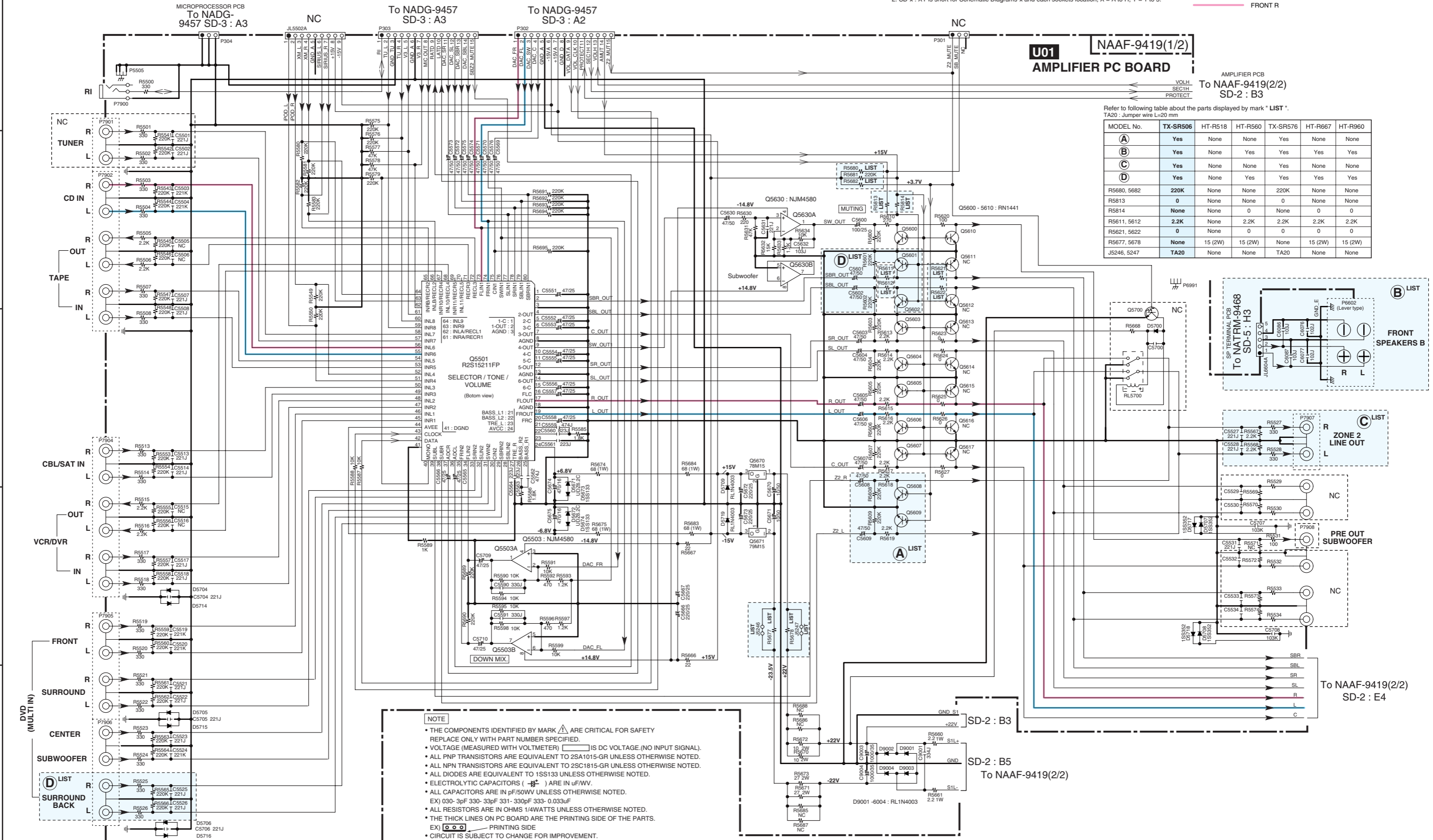

Refer to following table about the parts displayed by mark "LIST".  
TA20 : Jumper wire L=20 mm

MODEL No.	TX-SR506	HT-R518	HT-R560	TX-SR576	HT-R667	HT-R960
(A)	Yes	None	None	Yes	None	None
(B)	Yes	None	Yes	Yes	Yes	Yes
(C)	Yes	None	None	Yes	None	None
(D)	Yes	None	Yes	Yes	Yes	Yes
R5680, 5682	220K	None	None	220K	None	None
R5813	0	None	None	0	None	None
R5814	None	None	0	None	0	0
R5611, 5612	2.2K	None	2.2K	2.2K	2.2K	2.2K
R5621, 5622	0	None	0	0	0	0
R5677, 5678	None	15 (2W)	15 (2W)	None	15 (2W)	15 (2W)
J5246, 5247	TA20	None	None	TA20	None	None

# SCHEMATIC DIAGRAMS-2 (SD-2) POWER AMPLIFIER SECTION

U01 AMPLIFIER PC BOARD NAAF-9419 (2/2)

**<Note>**  
 1. NC = No mount of parts.  
 2. SD-x : XY is short for Schematic Diagrams-x and each sockets location, X = A to H, Y = 1 to 5.

AUDIO ANALOG SIGNAL  
 FRONT L  
 FRONT R

Refer to following table about the parts displayed by mark "LIST".

MODEL No. -->	TX-SR506		HT-R518	HT-R560	TX-SR576	HT-R667	HT-R960	
TYPE -->	MDD, MDC	MPP, MPB	MGK, MGQ, MGR	MWT, MWO, MWF	MDD, MDC	MPP	MDD, MDC	MPP
Q6050 - 6052	Yes	Yes	None	Yes	Yes	Yes	Yes	Yes
Q6060 - 6062	Yes	Yes	None	Yes	Yes	Yes	Yes	Yes
Q6053 - 6054	Yes	Yes	None	Yes	Yes	Yes	Yes	Yes
Q6063 - 6064	Yes	Yes	None	Yes	Yes	Yes	Yes	Yes
Q6055 - 6056	Yes	Yes	None	Yes	Yes	Yes	Yes	Yes
Q6065 - 6066	Yes	Yes	None	Yes	Yes	Yes	Yes	Yes
C6901, 6902	8200/63	10000/69	10000/63	10000/63	10000/63	10000/63	10000/69	10000/63
Q5050 - 56	2SC1815	2SC2240	2SC2240	2SC2240	2SC1815	2SC1815	2SC2240	2SC2240
R5160 - 5166	100(1/4W)	150(1/4W)	150(1/4W)	150(1/4W)	100(1/4W)	100(1/4W)	150(1/4W)	150(1/4W)
R5170 - 5176	100(1/4W)	150(1/4W)	150(1/4W)	150(1/4W)	100(1/4W)	100(1/4W)	150(1/4W)	150(1/4W)
R6070 - 6072	82(1/4W)	120(1/4W)	120(1/4W)	120(1/4W)	82(1/4W)	82(1/4W)	120(1/4W)	120(1/4W)
R6073 - 6076	100(1/4W)	120(1/4W)	120(1/4W)	120(1/4W)	100(1/4W)	100(1/4W)	120(1/4W)	120(1/4W)
R6710	5.6K	5.6K	4.7K	5.6K	5.6K	5.6K	4.7K	5.6K

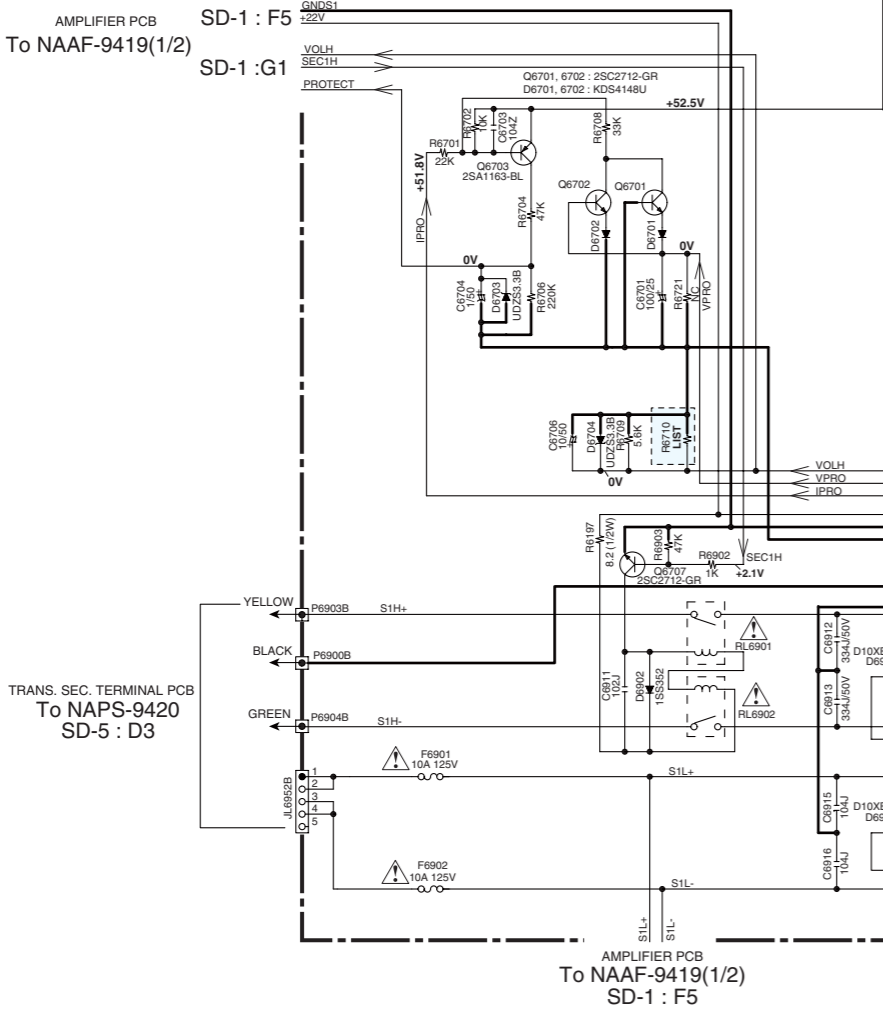
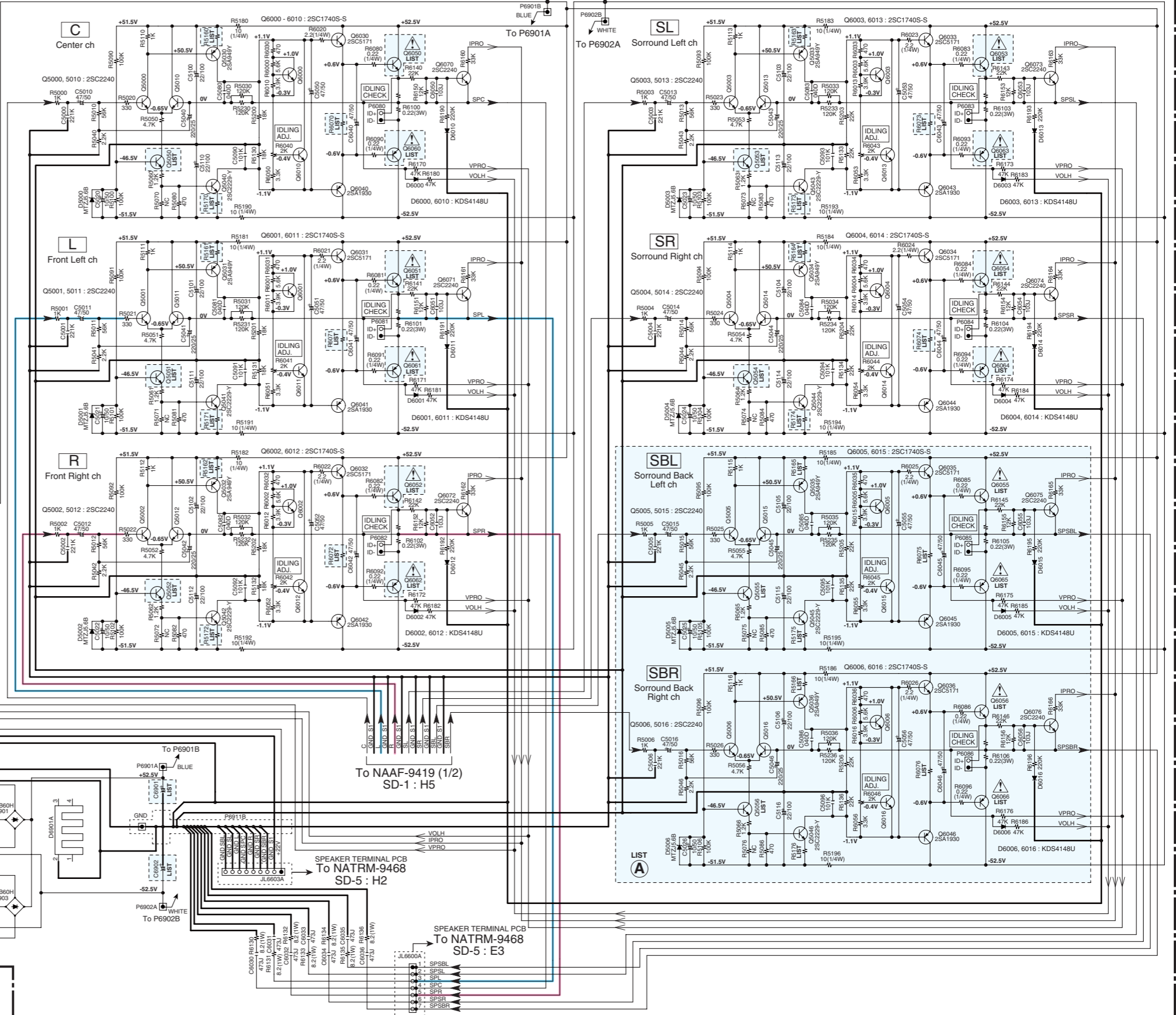

1  
2  
3  
4  
5

SCHEMATIC DIAGRAMS-3 (SD-3)

MICROPROCESSOR SECTION

DISPLAY PCB  
To NADIS-9430  
SD-6 : H1

To TUNER UNIT

VIDEO PCB  
To NAVD-9467  
SD-4 : H4

U30 MICROPROCESSOR PC BOARD

NADG-9457

1

NAETC-9421  
U03  
THERMAL SENSOR  
PC BOARD

2

AMP. PCB  
To NAAF-9419 (1/2)  
SD-1 : D1

3

AMP. PCB  
To NAAF-9419 (1/2)  
SD-1 : C1

4

AMP. PCB  
To NAAF-9419 (1/2)  
SD-1 : B1

5

Refer to following table about the parts displayed by mark \* LIST \*.

MODEL No.---->	TX-SR506				HT-R518	HT-R560	
TYPE-->	MDD, MDC	MPP, MPB	MKG, MGQ, MGR	MWT, MWO, MWF	MPP	MDD, MDC	MPP
R103	10(1/2W)	4.7(1/2W)	10(1/2W)	10(1/2W)	4.7(1/2W)	10(1/2W)	4.7(1/2W)
R104	NC	0	NC	NC	0	NC	0
R106, 107	0	NC	0	0	0	NC	NC
R610	10K	2.2K	10K	10K	2.2K	NC	2.2K
R611		NC			NC	220	NC
R612, 619	NC	1K	NC	NC	1K	NC	1K
R628, 629	NC	NC	NC	NC	NC	47	47
R630	10K	NC	10K	10K	NC	10K	NC
R631	NC	2.2K	NC	NC	2.2K	NC	2.2K
R632		NC			NC	10K	10K
R635		NC			NC	2.7K	2.7K
R642		NC			NC	47	NC
R644		NC			NC	220	NC
R655	NC	NC	NC	220	NC	NC	NC

Refer to following table about the parts displayed by mark \* LIST \*.

MODEL No.---->	TX-SR506				HT-R518	HT-R560	
TYPE-->	MDD, MDC	MPP, MPB	MKG, MGQ, MGR	MWT, MWO, MWF	MPP	MDD, MDC	MPP
(A)	Yes	Yes	Yes	Yes	None	None	None
(B)	Yes	Yes	Yes	Yes	None	Yes	Yes
R703	NC	10K	10K	10K	10K	33K	10K
R704	0	10K	NC	NC	10K	4.7K	10K
R705	NC	10K	10K	10K	10K	10K	33K
R706	0	10K	10K	10K	33K	NC	10K
R709	NC	10K	10K	10K	33K	10K	33K
R710	0	10K	10K	10K	4.7K	NC	10K

- NOTE
- THE COMPONENTS IDENTIFIED BY MARK  $\Delta$  ARE CRITICAL FOR SAFETY. REPLACE ONLY WITH PART NUMBER SPECIFIED.
  - VOLTAGE (MEASURED WITH VOLTMETER)  $\square$  IS DC VOLTAGE (NO INPUT SIGNAL).
  - ALL PNP TRANSISTORS ARE EQUIVALENT TO 2SA1015-GR UNLESS OTHERWISE NOTED.
  - ALL NPN TRANSISTORS ARE EQUIVALENT TO 2SC1815-GR UNLESS OTHERWISE NOTED.
  - ALL DIODES ARE EQUIVALENT TO 1SS133 UNLESS OTHERWISE NOTED.
  - ELECTROLYTIC CAPACITORS (  $\text{---}$  ) ARE IN  $\mu$ F/VV.
  - ALL CAPACITORS ARE IN pF/50V UNLESS OTHERWISE NOTED.
  - EX) 030-3pF 330-33pF 331-330pF 333-0.033 $\mu$ F
  - ALL RESISTORS ARE IN OHMS 1/4WATTS UNLESS OTHERWISE NOTED.
  - THE THICK LINES ON PC BOARD ARE THE PRINTING SIDE OF THE PARTS.
  - EX)  $\square$  PRINTING SIDE
  - CIRCUIT IS SUBJECT TO CHANGE FOR IMPROVEMENT.

- <Note>
1. NC = No mount of parts.
  2. SD-x : XY is short for Schematic Diagrams-x and each sockets location, X = A to H, Y = 1 to 5.
  3. Refer to SCHEMATIC DIAGRAMS-8 (SD-8) for digital audio waveform.

1 (DVD)  
2 (CBL/SAT)  
1 (VCR/DVR)  
2 (CD)

COAXIAL  
DIGITAL IN  
OPTICAL

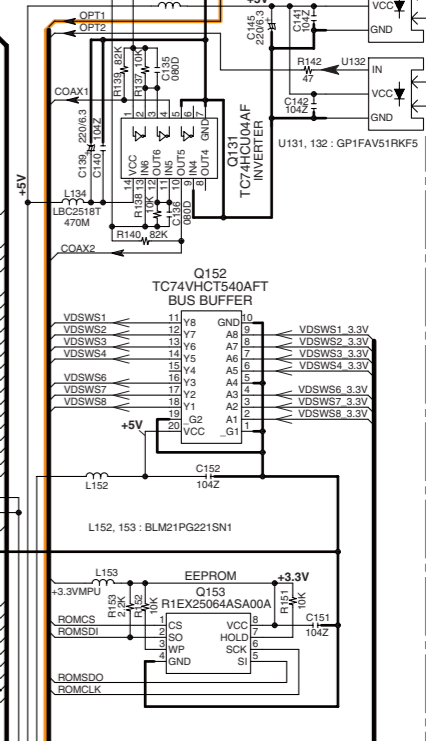
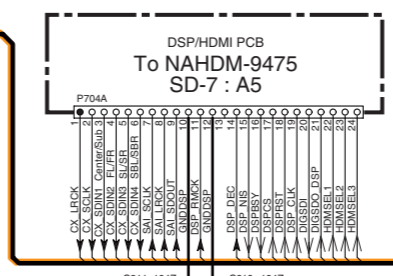
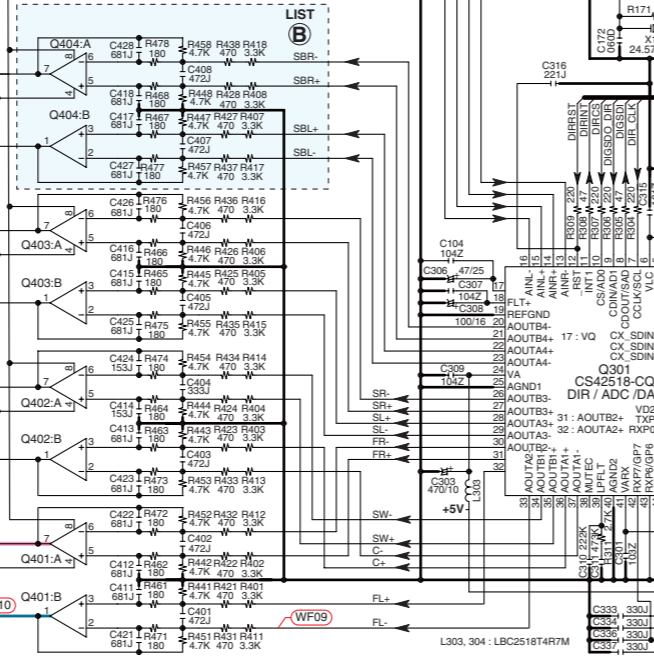
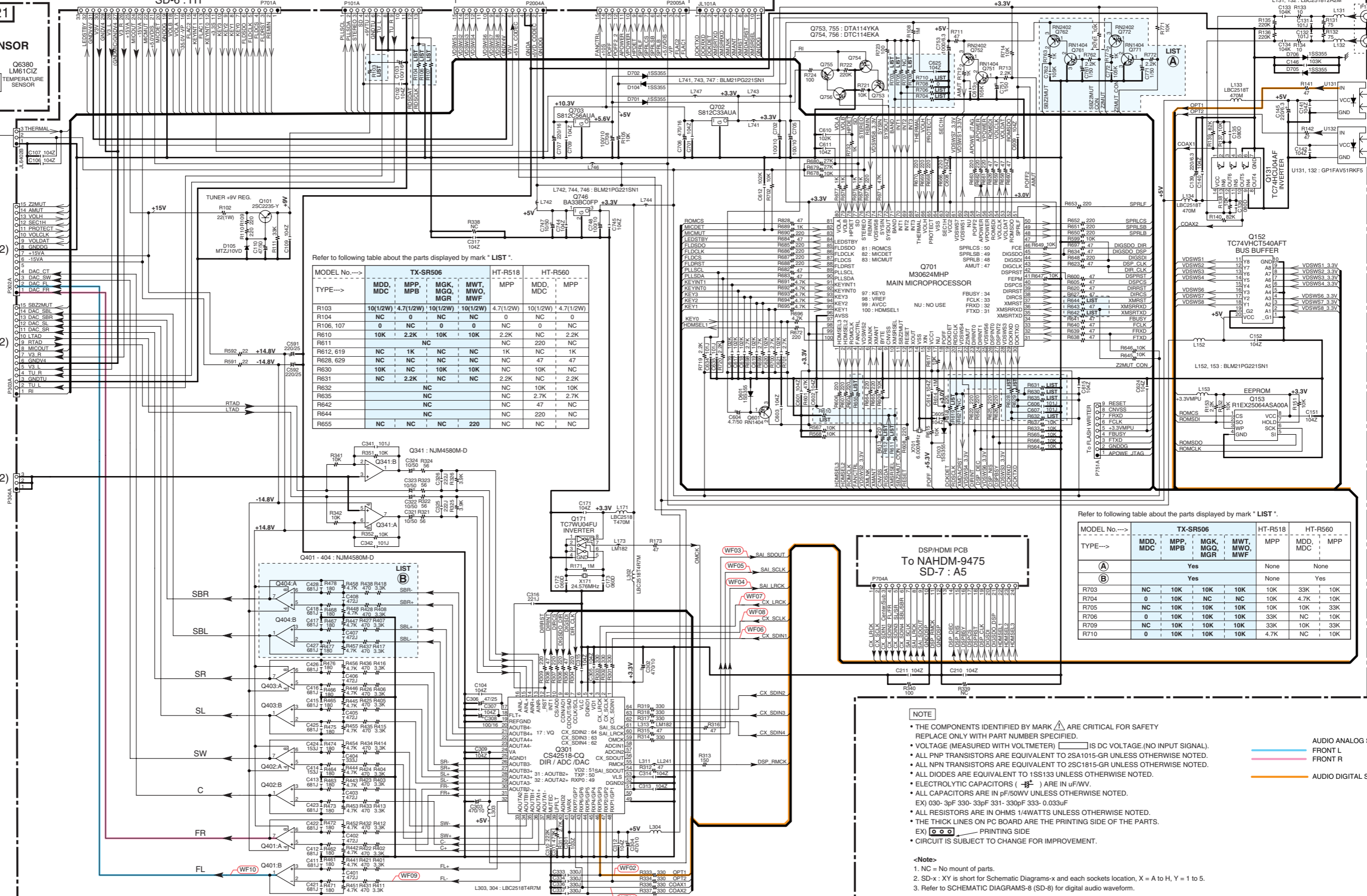

# SCHEMATIC DIAGRAMS-4 (SD-4) VIDEO SECTION

1

2

3

4

5

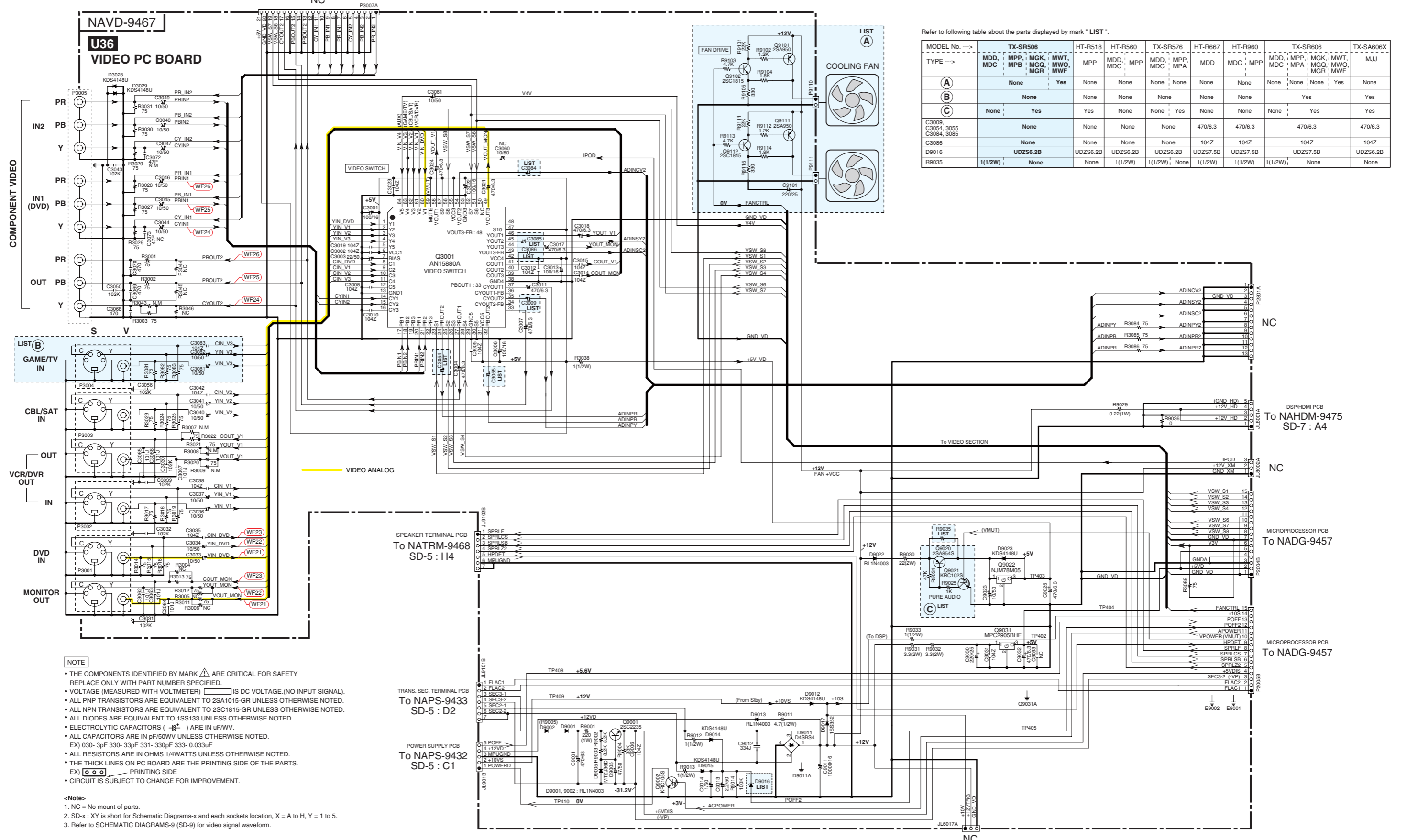

Refer to following table about the parts displayed by mark "LIST".

MODEL No. -->	TX-SR506				HT-R518	HT-R560	TX-SR576	HT-R667	HT-R960	TX-SR606			TX-SA606X	
TYPE -->	MDD, MDC	MPP, MPB	MGK, MGR	MWT, MWF	MPP	MDD, MDC	MPP, MPA	MDD	MDC	MPP	MDD, MDC	MPP, MPA	MGT, MGF, MWO, MWF	MJJ
(A)	None	None	Yes	None	None	None	None	None	None	None	None	None	Yes	None
(B)	None	None	None	None	None	None	None	None	None	None	None	Yes	None	Yes
(C)	None	None	Yes	Yes	None	None	Yes	None	None	None	None	Yes	None	Yes
C3009, C3054, 3055, C3084, 3085	None	None	None	None	None	None	None	470/6.3	470/6.3	None	None	470/6.3	None	470/6.3
C3086	None	None	None	None	None	None	None	104Z	104Z	None	None	104Z	None	104Z
D9016	UDZS6.2B	UDZS6.2B	UDZS6.2B	UDZS6.2B	UDZS6.2B	UDZS6.2B	UDZS7.5B	UDZS7.5B	UDZS7.5B	UDZS7.5B	UDZS7.5B	UDZS7.5B	UDZS6.2B	UDZS6.2B
R9035	1(1/2W)	None	None	None	1(1/2W)	None	1(1/2W)	1(1/2W)	1(1/2W)	1(1/2W)	1(1/2W)	None	None	None

**NOTE**

- THE COMPONENTS IDENTIFIED BY MARK  $\Delta$  ARE CRITICAL FOR SAFETY. REPLACE ONLY WITH PART NUMBER SPECIFIED.
- VOLTAGE (MEASURED WITH VOLTMETER) IS DC VOLTAGE. (NO INPUT SIGNAL).
- ALL PNP TRANSISTORS ARE EQUIVALENT TO 2SA1015-GR UNLESS OTHERWISE NOTED.
- ALL NPN TRANSISTORS ARE EQUIVALENT TO 2SC1815-GR UNLESS OTHERWISE NOTED.
- ALL DIODES ARE EQUIVALENT TO 1SS133 UNLESS OTHERWISE NOTED.
- ELECTROLYTIC CAPACITORS (  $\text{---}$  ) ARE IN  $\mu\text{F/WV}$ .
- ALL CAPACITORS ARE IN pF/50WV UNLESS OTHERWISE NOTED.  
EX) 030 - 3pF 330 - 33pF 331 - 330pF 333 - 0.033 $\mu\text{F}$
- ALL RESISTORS ARE IN OHMS 1/4WATTS UNLESS OTHERWISE NOTED.
- THE THICK LINES ON PC BOARD ARE THE PRINTING SIDE OF THE PARTS.  
EX)  $\square$  PRINTING SIDE
- CIRCUIT IS SUBJECT TO CHANGE FOR IMPROVEMENT.

**<Note>**

1. NC = No mount of parts.
2. SD-x : XY is short for Schematic Diagrams-x and each sockets location, X = A to H, Y = 1 to 5.
3. Refer to SCHEMATIC DIAGRAMS-9 (SD-9) for video signal waveform.

SPEAKER TERMINAL PCB  
To NATRM-9468  
SD-5 : H4

TRANS. SEC. TERMINAL PCB  
To NAPS-9433  
SD-5 : D2

POWER SUPPLY PCB  
To NAPS-9432  
SD-5 : C1

To VIDEO SECTION

To DSP/HDMI PCB  
To NAHDM-9475  
SD-7 : A4

To MICROPROCESSOR PCB  
To NADG-9457

To MICROPROCESSOR PCB  
To NADG-9457

NC



# SCHEMATIC DIAGRAMS-6 (SD-6) DISPLAY SECTION

**NOTE**

- THE COMPONENTS IDENTIFIED BY MARK  $\Delta$  ARE CRITICAL FOR SAFETY. REPLACE ONLY WITH PART NUMBER SPECIFIED.
- VOLTAGE (MEASURED WITH VOLTMETER)  $\square$  IS DC VOLTAGE (NO INPUT SIGNAL).
- ALL PNP TRANSISTORS ARE EQUIVALENT TO 2SA1015-GR UNLESS OTHERWISE NOTED.
- ALL NPN TRANSISTORS ARE EQUIVALENT TO 2SC1815-GR UNLESS OTHERWISE NOTED.
- ALL DIODES ARE EQUIVALENT TO 1SS133 UNLESS OTHERWISE NOTED.
- ELECTROLYTIC CAPACITORS (  $\square$  ) ARE IN  $\mu$ F/WV.
- ALL CAPACITORS ARE IN pF/50VWV UNLESS OTHERWISE NOTED.
- EX) 030-3pF 330-33pF 331-330pF 333-0.033 $\mu$ F
- ALL RESISTORS ARE IN OHMS 1/4WATS UNLESS OTHERWISE NOTED.
- THE THICK LINES ON PC BOARD ARE THE PRINTING SIDE OF THE PARTS.
- EX)  $\square$  PRINTING SIDE
- CIRCUIT IS SUBJECT TO CHANGE FOR IMPROVEMENT.

**<Note>**

1. NC = No mount of parts.
2. SD-x : XY is short for Schematic Diagrams-x and each sockets location, X = A to H, Y = 1 to 5.
3. Refer to SCHEMATIC DIAGRAMS-10 (SD-10) for FL driver IC control waveform.

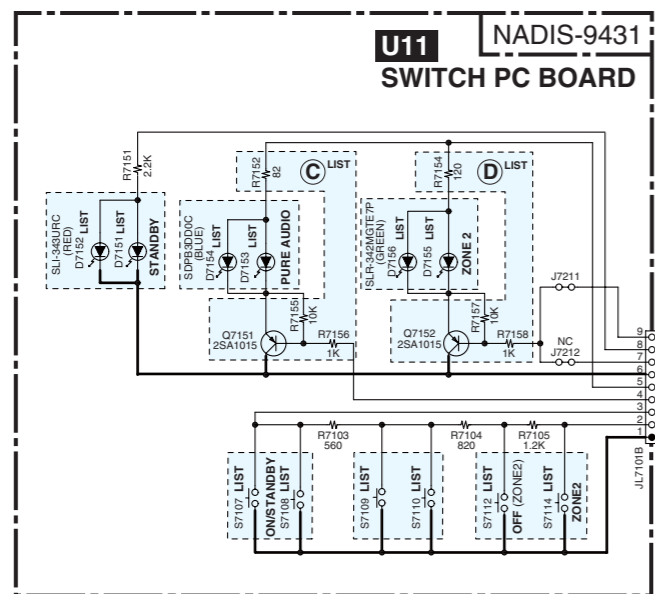

Refer to following table about the parts displayed by mark \* LIST \*.

MODEL No.→	TX-SR506		HT-R518	HT-R560	TX-SR576	HT-R667	HT-R960	TX-SR606	TX-SA606X		
TYPE→	MDD, MDC	MPP, MGK, MW, MPB, MGQ, MWO, MGR, MWF	MPP	MDD, MPP, MDC	MDD, MDC	MPP, MPA	MDD	MDC, MPP	MDD, MDC	MPP, MGK, MW, MPA, MGO, MWO, MPB, MGR, MWF	MJ
(A)		Yes	Yes	Yes	Yes	Yes	Yes	None	None		None
(B)		None	None	None	None	None	None	Yes	Yes		Yes
(C)		None	Yes	None	None	Yes	None	None	Yes		Yes
(D)		Yes	None	None	Yes	None	None	Yes	None		None
D7151		Yes	Yes	Yes	Yes	Yes	Yes	None	None		None
D7152		None	None	None	None	None	None	Yes	Yes		Yes
D7153		None	Yes	None	None	Yes	None	None	None		None
D7154		None	None	None	None	None	None	None	Yes		Yes
D7155		None	None	None	None	None	None	Yes	None		None
D7156		Yes	None	None	Yes	None	None	None	None		None
S7001, S7107		Yes	Yes	Yes	Yes	Yes	Yes	None	None		None
S7002, S7108		None	None	None	None	None	None	Yes	Yes		Yes
S7109		MUSIC OPTIMIZER, PURE AUDIO	PURE AUDIO	DOCK	MUSIC OPTIMIZER, PURE AUDIO	DOCK	THX	None	None		None
S7110		None	None	None	None	None	None	None	PURE AUDIO		PURE AUDIO
S7112, S7114		None	None	None	None	None	None	Yes	None		None

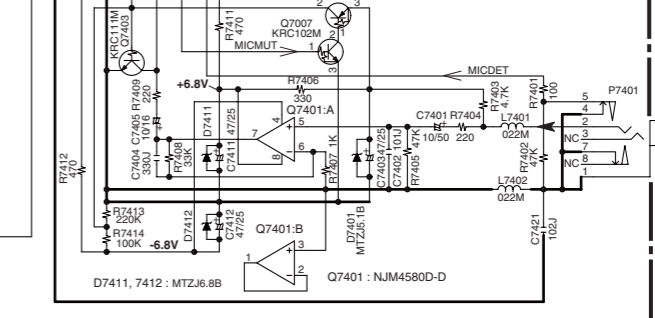
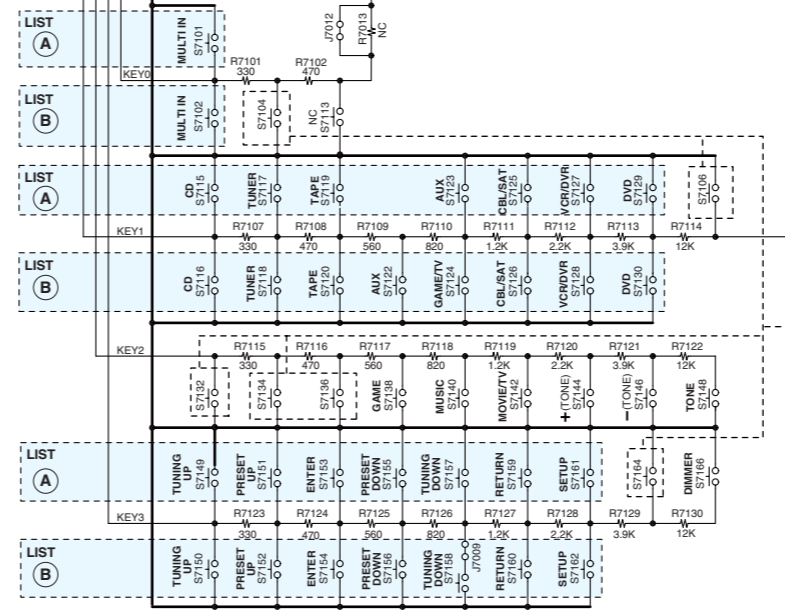
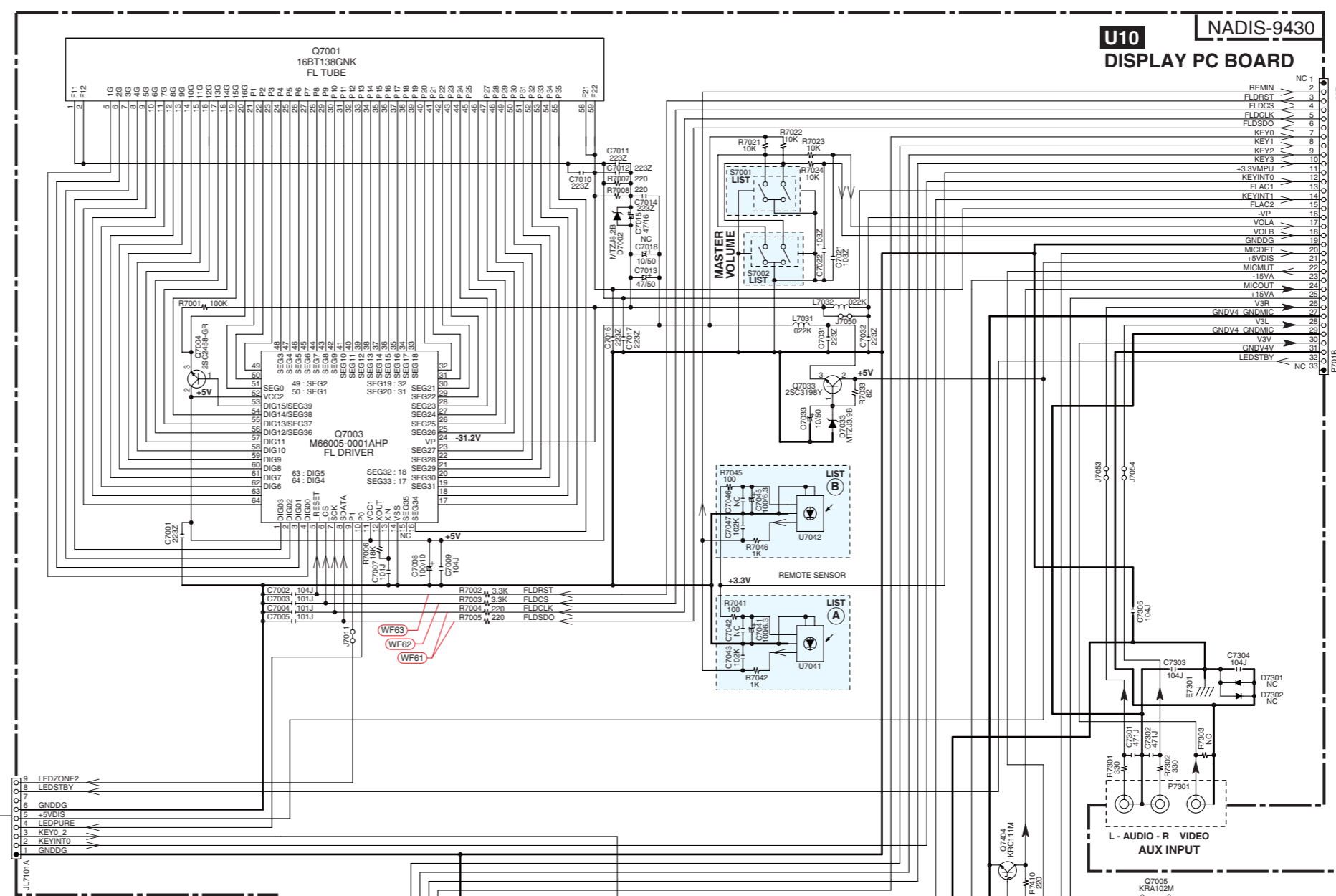

**FUNCTION**

MODEL No.→	TX-SR506 TX-SR576	HT-R518	HT-R560 HT-R667 HT-R960	TX-SR606	TX-SA606X
S7104	OFF (ZONE2)	LATE NIGHT	SPEAKERS B	ZONE2 LEVEL UP	DIGITAL IN
S7106	ZONE2	CINEMA FILTER	SPEAKERS A	ZONE2 LEVEL DOWN	DISPLAY
S7132	MEMORY	MEMORY	MEMORY	MEMORY	CINEMA FILTER
S7134	DIGITAL INPUT	DIGITAL INPUT	DIGITAL INPUT	DIGITAL INPUT	None
S7136	DISPLAY	DISPLAY	DISPLAY	DISPLAY	None
S7164	TUNING MODE	TUNING MODE	TUNING MODE	TUNING MODE	LATE NIGHT

MICROPROCESSOR PCB  
To NADG-9457  
SD-3 : A2



# SCHEMATIC DIAGRAMS-7 (SD-7)

## DSP / HDMI SECTION

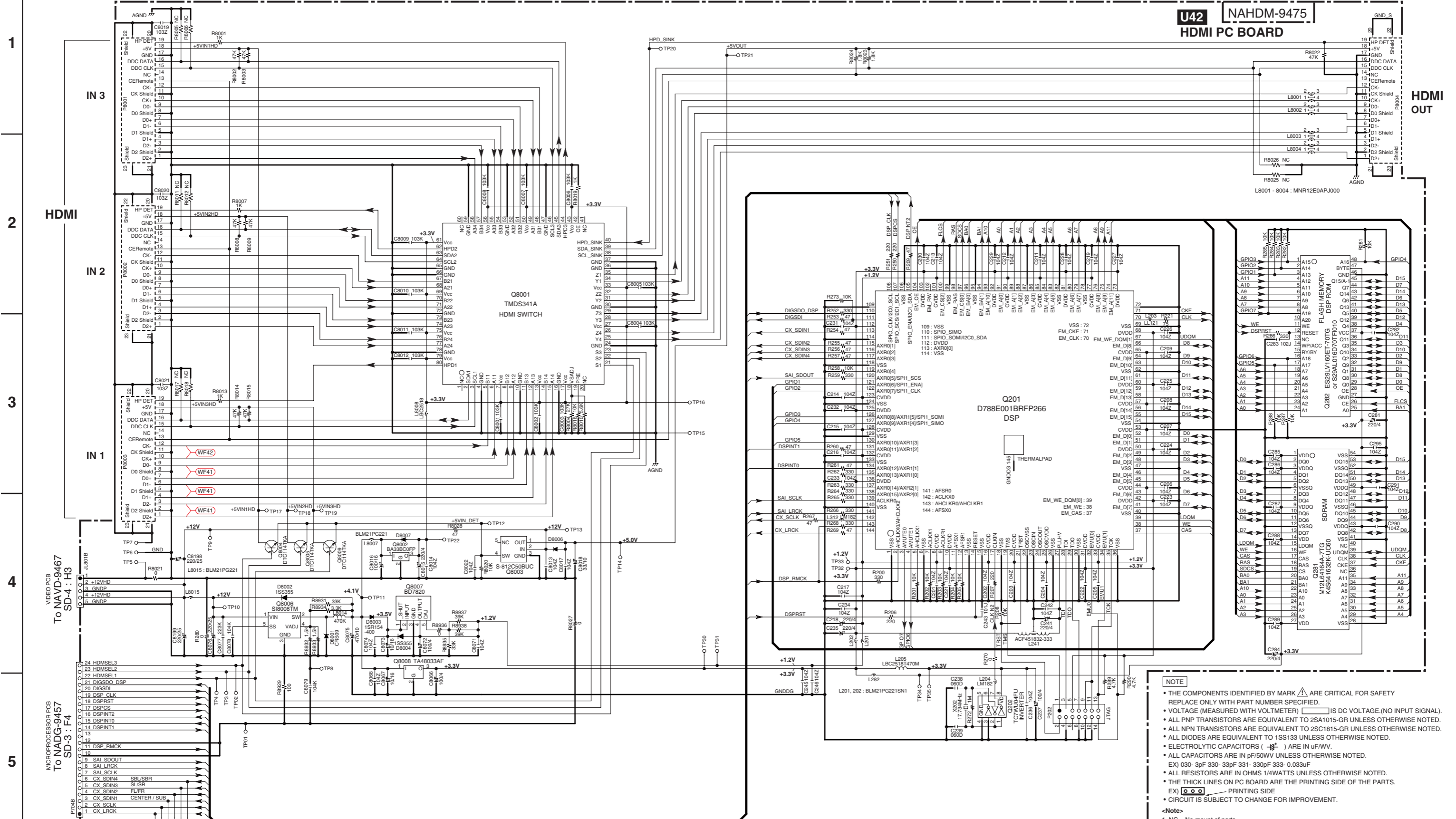

**NOTE**

- THE COMPONENTS IDENTIFIED BY MARK ARE CRITICAL FOR SAFETY. REPLACE ONLY WITH PART NUMBER SPECIFIED.
- VOLTAGE (MEASURED WITH VOLTMETER) IS DC VOLTAGE. (NO INPUT SIGNAL).
- ALL PNP TRANSISTORS ARE EQUIVALENT TO 2SA1015-GR UNLESS OTHERWISE NOTED.
- ALL NPN TRANSISTORS ARE EQUIVALENT TO 2SC1815-GR UNLESS OTHERWISE NOTED.
- ALL DIODES ARE EQUIVALENT TO 1SS133 UNLESS OTHERWISE NOTED.
- ELECTROLYTIC CAPACITORS ( ) ARE IN uF/WV.
- ALL CAPACITORS ARE IN pF/50WV UNLESS OTHERWISE NOTED.
- EX) 030- 3pF 330- 33pF 331- 330pF 333- 0.033uF
- ALL RESISTORS ARE IN OHMS 1/4WATTS UNLESS OTHERWISE NOTED.
- THE THICK LINES ON PC BOARD ARE THE PRINTING SIDE OF THE PARTS.
- EX) PRINTING SIDE
- CIRCUIT IS SUBJECT TO CHANGE FOR IMPROVEMENT.

**<Note>**

1. NC = No mount of parts.
2. SD-x : XY is short for Schematic Diagrams-x and each sockets location, X = A to H, Y = 1 to 5.
3. Refer to SCHEMATIC DIAGRAMS-9 (SD-9) for HDMI signal waveform.