

ONKYO SERVICE MANUAL

AV RECEIVER MODEL TX-SR600/E

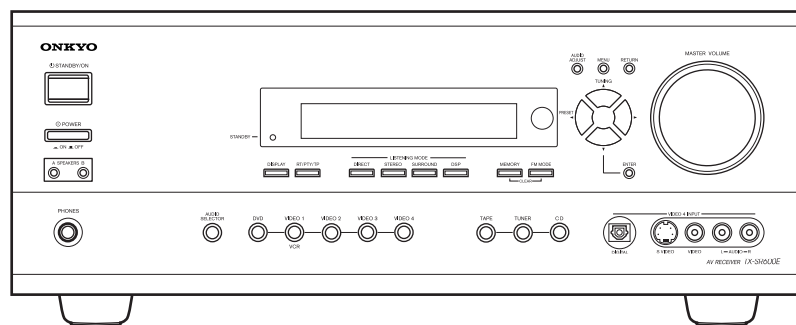

Black, Golden and Silver models

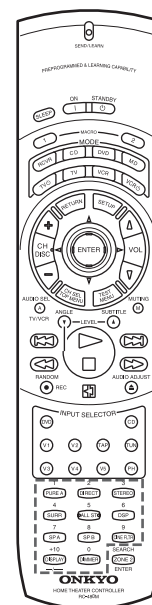

RC-480M

BMDD,BMDC	120V AC, 60Hz
BMPP,BMPA,SMPP,GMPA	230~240V AC, 50Hz
BMWT,GMWT,GMWR,GMWQ	120/220~230V AC, 50/60Hz
GMGK	220V AC, 50Hz

SAFETY-RELATED COMPONENT WARNING!!

COMPONENTS IDENTIFIED BY MARK  ON THE SCHEMATIC DIAGRAM AND IN THE PARTS LIST ARE CRITICAL FOR RISK OF FIRE AND ELECTRIC SHOCK. REPLACE THESE COMPONENTS WITH ONKYO PARTS WHOSE PART NUMBERS APPEAR AS SHOWN IN THIS MANUAL.

MAKE LEAKAGE-CURRENT OR RESISTANCE MEASUREMENTS TO DETERMINE THAT EXPOSED PARTS ARE ACCEPTABLY INSULATED FROM THE SUPPLY CIRCUIT BEFORE RETURNING THE APPLIANCE TO THE CUSTOMER.

SPECIFICATIONS

AMPLIFIER SECTION

Continuous average power output (FTC)

All channels: **80 W per channel min. RMS at 8 ohm, 2 channels driven from 20 Hz to 20 kHz with no more than 0.08% total harmonic distortion.**
105 W min. RMS at 6 ohm, 2 channels driven from 1 kHz with no more than 0.1% total harmonic distortion.

Continuous power output (DIN)

115 W at 6ohm

Maximum power output (EIAJ)

145 W at 6ohm

Dynamic power output (stereo)

2 × 215 W at 3 ohm

2 × 160 W at 4 ohm

2 × 95 W at 8 ohm

Total harmonic distortion:

0.08% at rated power

0.08% at 1 W output

IM distortion:

0.08% at rated power

0.08% at 1 W output

Damping factor:

60 at 8 ohm

Input sensitivity and impedance

LINE (CD, TAPE, DVD,

VIDEO 1-4):

200 mV, 47 kohm

MULTICHANNEL INPUT

(FRONT L/C/R, SURROUND

L/R):

200 mV, 47 kohm

(SUBWOOFER):

36 mV, 47 kohm

COAXIAL (DIGITAL):

0.5 Vp-p, 75 ohm

DVD, VIDEO 1, 2, 3, 4:

1 Vp-p, 75 ohm

1 Vp-p, 75 ohm (Y)

0.28 Vp-p, 75 ohm (C)

COMPONENT VIDEO 1, 2:

1 Vp-p, 75 ohm (Y)

0.7 Vp-p, 75 ohm (Pb, Pr)

Output level and impedance

Rec out (TAPE, VIDEO 1):

200 mV, 470 ohm

Pre out:

1 V, 470 ohm

VIDEO (VIDEO 1,

MONITOR OUT):

1 Vp-p, 75 ohm

1 Vp-p, 75 ohm (Y)

0.28 p-p, 75 ohm (C)

COMPONENT VIDEO OUT:

1 Vp-p, 75 ohm (Y)

0.7 Vp-p, 75 ohm (Pb, Pr)

Frequency response:

10 Hz to 100 kHz: +1/-3 dB
(CD in Direct mode)

RIAA deviation:

20 Hz to 20 kHz: ±0.8 dB

Tone control

Bass:

±12 dB at 50 Hz

Treble:

±12 dB at 20,000 Hz

Signal-to-noise ratio (stereo)

CD/Tape:

100 dB (IHF A, 0.5 V input)

Muting:

-50 dB

TUNER SECTION

FM

Tuning range:

87.5-108.0 MHz (50-kHz steps)

Usable sensitivity

Mono:

11.2 dBf, 1.0 μV (75 ohm IHF)

0.9 μV (75 ohm DIN)

Stereo:

17.2 dBf, 2.0 μV (75 ohm IHF)

23 μV (75 ohm DIN)

50 dB quieting sensitivity

Mono:

17.2 dBf, 2.0 μV (75 ohm)

Stereo:

37.2 dBf, 20 μV (75 ohm)

Capture ratio:

2.0 dB

Image rejection ratio

USA & Canadian models:

40 dB

Other area models:

85 dB

IF rejection ratio:

90 dB

Signal-to-noise ratio

Mono:

76 dB

Stereo:

70 dB

Alternate channel attenuation:

55 dB

Selectivity:

50 dB (DIN)

AM suppression ratio:

50 dB

Total harmonic distortion

Mono:

0.2%

Stereo:

0.3%

Frequency response:

30 Hz - 15 kHz, ±1.0 dB

Stereo separation:

45 dB at 1 kHz

30 dB at 100 Hz - 10 kHz

AM

Tuning range

USA & Canadian models:

530 to 1,710 kHz (10-kHz steps)

European & Australian models:

522 to 1,611 kHz (9-kHz steps)

Worldwide models:

531 to 1,602 kHz (9-kHz steps)

Usable sensitivity:

30 μV

Image rejection ratio:

40 dB

IF rejection ratio:

40 dB

Signal-to-noise ratio:

40 dB

Total harmonic distortion:

0.7%

GENERAL

Power supply

USA & Canadian models:

AC 120 V, 60 Hz

European & Australian models:

AC 230 - 240 V, 50 Hz

Some Asian models:

AC 220 - 230 V, 50/60 Hz

Worldwide models:

AC 220 - 230 and 120 V switchable,

50/60 Hz

Power consumption

USA & Canadian models:

5.5 A

Other models:

450 W

Dimensions (W×H×D):

435×175×431.5 mm

17-1/8"×6-7/8"×16-15/16"

Weight

USA & Canadian models:

24.5 lbs.

Other models:

12.1 kg

REMOTE CONTROLLER

Transmitter:

Infrared

Signal range:

Approx. 16 ft., 5 meters

Power supply:

Two "AA" batteries (1.5 V × 2)

Specifications and features are subject to change without notice.

SERVICE PROCEDURES

1. Replacing the fuses



This symbol located near the fuses indicates that the fuse used is fast operating type. For continued protection against fire hazard, replace with same type fuse. For fuse rating refer to the marking adjacent to the symbol.



Ce symbole indique que le fusible utilise est a rapide. Pour une protection permanente, n'utiliser que fusibles de meme type. Ce dernier est la qu le present symbol est appse.

CIRCUIT NO.	PART NO.	DESCRIPTION
F6901,F6902	252199	10A-UL,Fuse <D>
	252100	10A-EAK,Fuse <O>
F901	252198 or 252261	8A-UL or 8A-T/UL-ST2,Fuse <D/T/Q/R>
F902	252077, 252243 or 252277	4A-SE-EAK, 4A-SE-TL250V or 4A-SE-TL250V,Fuse <O>
F903	252075, 252241 or 252275	2.5A-SE-EAK, 2.5A-SE-TL250V or 2.5A-SE-TL250V,Fuse <O>
F9501	252160 or 252254	2.5A-UL/T-237 or 2.5A-T/UL-ST2,Fuse <D>
	252075, 252241 or 252275	2.5A-SE-EAK, 2.5A-SE-TL250V or 2.5A-SE-TL250V,Fuse <O>

Note: <D>:120V model only
<O>: Other models except 120V model
<T>: Asian model only for 230V
<R>: Chinese model only

2. To initialize the unit

This device employs a microprocessor to perform various functions and operations. If interference generated by an external power supply, radio wave, or other electrical source results in accident which causes the specified operations and functions to operate abnormally.

To perform a result, please follow the procedure below.

- 1.Press and hold down the VIDEO-1 button, then press the STANDBY/ON button.
- 2.After "clear" is displayed, the preset memory and each mode stored in the memory, such as surround, are initialized and will return to the factory setting.

3. Safety-check out

(Only U.S.A. model)

After correcting the original service problem, perform the following safety check before releasing the set to the customer. Connect the insulating-resistance tester between the plug of power supply cord and screw on the back panel.

Specifications: 3.3Mohm+/-10% at 500V.

4. Memory Preservation

This unit does not require memory preservation batteries. A built-in memory power back-up system preserves the contents of the memory during power failures and even when the unit is unplugged. The unit must be plugged in order to charge the back-up system.

The memory preservation period after the unit has been unplugged varies depending on climate and placement of the unit. On the average, memory contents are protected over a period of a few weeks after the last time the unit has been unplugged. This period is shorter when the unit is exposed to a highly humid climate.

5.Setting the voltage selector (Worldwide models only)

Worldwide models are equipped with a voltage selector to conform with local power supplies. Be sure to set this switch to match the voltage of the power supply in your area before plugging in the unit.

Determine the proper voltage for your area: 220-230 V or 120 V. If the preset voltage is not correct for your area, insert a screwdriver into the groove in the switch. Slide the switch all the way to the upper (120 V) or to the lower (220-230 V), whichever is appropriate.

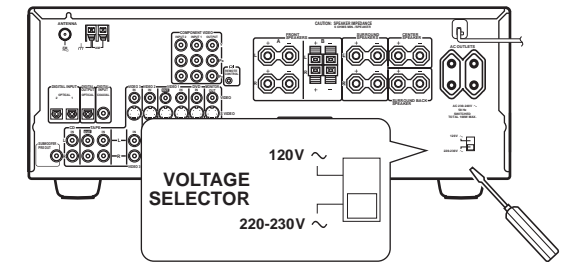

6.Setting the AM tuning step frequency

(Worldwide models only)

1. Press the MENU button on the front panel or SETUP button on the remote controller.

The main menu appears.

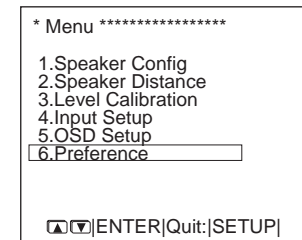

2. Use the ▲ and ▼ cursor buttons to select "6. Preference" and then press the ENTER button.

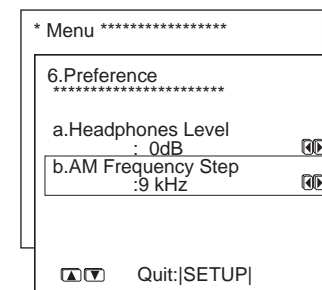

b. AM Frequency Step

This setting only appears on the worldwide model. It determines the increment amount or decrement amount when adjusting the AM tuner frequency. The initial setting is 9 kHz, and this needs only to be changed if you are using the unit in a 10-kHz region.

EXPLODED VIEW

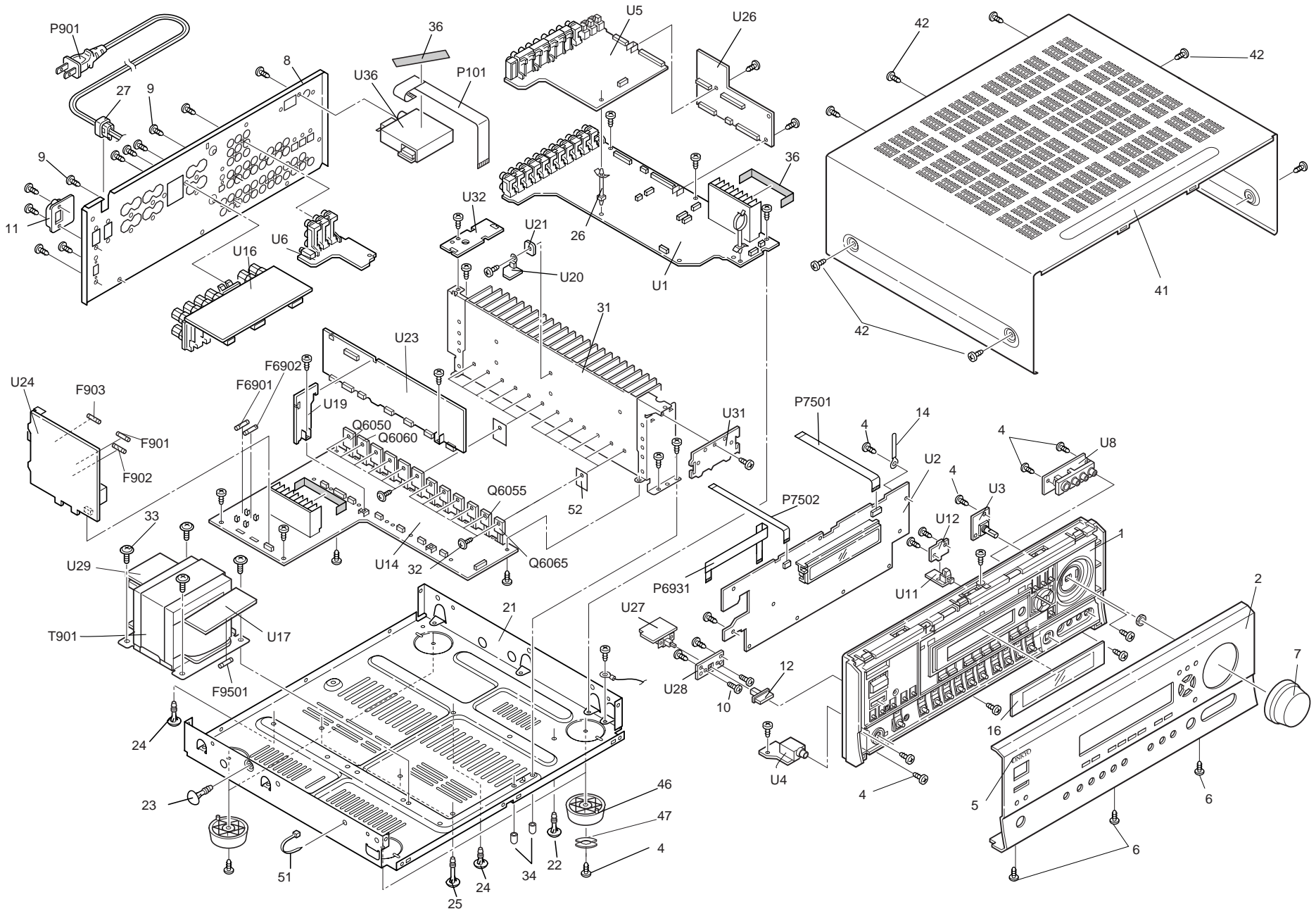

EXPLODED VIEW

PARTS LIST

NOTE: :Black model only <D>:120V model only <A>:Australian model only
 <S>:Silver model only <O>:Other models except 120V model <R>:Chinese model only
 <G>:Golden model only <P>:European model only <Q>:Hongkong model only
 <T>:Asian model only <K>:korean model only

REF.NO.	PART NO.	DESCRIPTIONS	REF.NO.	PART NO.	DESCRIPTIONS
1	27111271B	Front bracket 	F901	252198 or	△ 8A-UL or
	27111273B	Front bracket <G>		252261	△ 8A-T/UL-ST2,Fuse <D/T/Q/R>
	27111272B	Front bracket <S>	F902	252077,	△ 4A-SE-EAK,
2	27212382	Front panel <D>		252243 or	△ 4A-SE-TL250V or
	27212383	Front panel <T/A>		252277	△ 4A-SE-TL250V,Fuse <O>
	27212384	Front panel <P>	F903	252075,	△ 2.5A-SE-EAK,
	27212385	Front panel <S>		252241 or	△ 2.5A-SE-TL250V or
	27212386	Front panel <G>		252275	△ 2.5A-SE-TL250V,Fuse <O>
4	838130088	3TTB+8B,Self-tapping screw	F9501	252160 or	△ 2.5A-UL/T-237 or
5	28135244	Badge 		252254	△ 2.5A-T/UL-ST2,Fuse <D>
	28135245	Badge <G/S>		252075,	△ 2.5A-SE-EAK,
6	838430088	3TTB+8B(BC),Self-tapping screw		252241 or	△ 2.5A-SE-TL250V or
7	28325907	Knob, volume <D>		252275	△ 2.5A-SE-TL250V,Fuse <O>
	28326010	Knob, volume <O>	P101	2047152522	NCFC7-152522,Flexible cable
	28326011	Knob, volume <S>	P6931	2047134512	NCFC7-134512,Flexible cable
	28326012	Knob, volume <G>	P7501	2047113022	NCFC7-113022,Flexible cable
8	27122964A	Rear panel <D>	P7502	2047061522	NCFC7-061522,Flexible cable
	27122965A	Rear panel <P>	P901	253332HIT or	△ AS-UC-2 or
	27122966A	Rear panel <T>		253333VOL	△ AS-UC-2,Power supply cord <D>
	27122967A	Rear panel <A>		253197HIT or	△ AS-SAA or
	27122968A	Rear panel <R/Q>		253307VOL	△ AS-SAA,Power supply cord <A>
	27122970A	Rear panel <K>		253233KAW	△ AS-CEE-2,Power supply cord <P/T/K>
9	838430088	3TTB+8B(BC),Self-tapping screw		253198HIT	△ AS-BS,Power supply cord <Q>
10	82143010	3P+10FN(BC),Pan head screw		253337HIT or	△ AS-CCEE or
11	27191130	Holder, outlet <R>		253338VOL	△ AS-CCEE,Power supply cord <R>
12	28325497A	Knob, power <O>	P902A	25052665	△ NSCT-2P2561,AC outlet <K>
	28325499A	Knob, power <G>	Q6050~	2202843 or	* 2SC5242-O or
	28325547A	Knob, power <S>	Q6052	2202842	* 2SC5242-R,Transistor
14	27255004	CS-1U,Clip	Q6053~	2203663,	* MN130S-O,
16	28191957	Clear plate 	Q6055	2202842,	* 2SC5242-R,
	28191958	Clear plate <G/S>		2202843,	* 2SC5242-O,
21	27100418A	Chassis		2203664 or	* MN130S-Y or
22	27190693A	KGLS-6RF,Holder		2203666	* MN130S-P,Transistor
23	27190428A	KGLS-10RF,Holder	Q6060~	2202833 or	* 2SA1962-O or
24	27190266	KGLS-12RF,Holder	Q6062	2202832	* 2SA1962-R,Transistor
25	27190657	KGLS-18RF,Holder	Q6063~	2203673,	* MP130S-O,
26	27190369	Holder	Q6065	2202832,	* 2SA1962-R,
27	27300750	△ Bushing, cord		2202833,	* 2SA1962-O,
31	27160504	Heat sink		2203674 or	* MP130S-Y or
32	801433	3SMS8W.SW+14B(BC),Self-tapping screw		2203676	* MP130S-P,Transistor
33	830440089	4TTC+8C(BC),Self-tapping screw	T901	2301584	△ NPT-1438D,Power transformer <D>
34	28330135A	Cap		2301585	△ NPT-1438P,Power transformer <P/A>
36	29110083	Tape,cloth		2301586	△ NPT-1438DG,Power transformer <T/K/Q/R>
41	28184835	Top cover 			
	28184837	Top cover <G>			
	28184836	Top cover <S>			
42	838430088	3TTB+8B(BC),Self-tapping screw 			
	838930088	3TTB+8B(UN),Self-tapping screw <G/S>			
46	27175319B	Leg			
47	28141494	Cushion			
51	260208	Binder			
52	223024	AC238,Isolated sheet			
F6901,	252199	10A-UL,Fuse <D>			
F6902	252100	10A-EAK,Fuse <O>			

CAUTION: Replacement for transistor of mark *, if necessary must be made from the same beta group (HFE) as the original type.

NOTE: THE COMPONENTS IDENTIFIED BY MARK △ ARE CRITICAL FOR RISK OF FIRE AND ELECTRIC SHOCK. REPLACE ONLY WITH PART NUMBER SPECIFIED.

EXPLODED VIEW

PARTS LIST

NOTE: :Black model only <D>:120V model only <A>:Australian model only
 <S>:Silver model only <O>:Other models except 120V model <R>:Chinese model only
 <G>:Golden model only <P>:European model only <Q>:Hongkong model only
 <T>:Asian model only <K>:korean model only

REF.NO.	PART NO.	DESCRIPTIONS	REF.NO.	PART NO.	DESCRIPTIONS
U1	1A929560-1A	NADG-7460-1A,Main circuit PC board ass'y <D>	U27	1A929587-1B	NASW-7487-1B,Power switch PC board ass'y <P>
	1A929560-1B	NADG-7460-1B,Main circuit PC board ass'y <P>		1A929587-1C	NASW-7487-1C,Power switch PC board ass'y <A>
	1A929560-1C	NADG-7460-1C,Main circuit PC board ass'y <A/K>		1A929587-1D	NASW-7487-1D,Power switch PC board ass'y <R>
	1A929560-1D	NADG-7460-1D,Main circuit PC board ass'y <T/R/Q>		1A929587-1E	NASW-7487-1E,Power switch PC board ass'y <T/Q>
U2	1A929561-1A	NADIS-7461-1A,Display circuit PC board ass'y <D>		1A929587-1F	NASW-7487-1F,Power switch PC board ass'y <K>
	1A929561-1B	NADIS-7461-1B,Display circuit PC board ass'y <O>	U28	1A929588-1B	NAETC-7488-1B,PC board for holder <P>
U3	1A929562-1A	NASW-7462-1A,Volume PC board ass'y <D>		1A929588-1C	NAETC-7488-1C,PC board for holder <A>
	1A929562-1B	NASW-7462-1B,Volume PC board ass'y <O>		1A929588-1D	NAETC-7488-1D,PC board for holder <R>
U4	1A929563-1A	NAETC-7463-1A,Headphone terminal PC board ass'y <D>		1A929588-1E	NAETC-7488-1E,PC board for holder <T/Q>
	1A929563-1B	NAETC-7463-1B,Headphone terminal PC board ass'y <O>		1A929588-1F	NAETC-7488-1F,PC board for holder <K>
U5	1A929564-1A	NAVD-7464-1A,Video terminal PC board ass'y <D>	U29	1A929589-1A	NAPS-7489-1A,Terminal PC board ass'y <D>
	1A929564-1B	NAVD-7464-1B,Video terminal PC board ass'y <O>		1A929589-1B	NAPS-7489-1B,Terminal PC board ass'y <P>
U6	1A929565-1A	NAVD-7465-1A,Componenet video terminal PC board ass'y <D>		1A929589-1C	NAPS-7489-1C,Terminal PC board ass'y <A>
	1A929565-1B	NAVD-7465-1B,Componenet video terminal PC board ass'y <O>		1A929589-1D	NAPS-7489-1D,Terminal PC board ass'y <R>
U8	1A929567-1A	NAVD-7467-1A,Front video PC board ass'y <D>		1A929589-1E	NAPS-7489-1E,Terminal PC board ass'y <T/Q>
	1A929567-1B	NAVD-7467-1B,Front video PC board ass'y <O>		1A929589-1F	NAPS-7489-1F,Terminal PC board ass'y <K>
U11	1A929570-1A	NADG-7470-1A,Front optical input PC board ass'y <D>	U31	1A929591-1A	NAETC-7491-1A,PC board for holder <D>
	1A929570-1B	NADG-7470-1B,Front optical input PC board ass'y <O>		1A929591-1B	NAETC-7491-1B,PC board for holder <P>
U12	1A929571-1A	NAETC-7471-1A,PC board for holder <D>		1A929591-1C	NAETC-7491-1C,PC board for holder <A>
	1A929571-1B	NAETC-7471-1B,PC board for holder <O>		1A929591-1D	NAETC-7491-1D,PC board for holder <R>
U14	1A929574-1A	NAAF-7474-1A,Power amplifier PC board ass'y <D>		1A929591-1E	NAETC-7491-1E,PC board for holder <T/Q>
	1A929574-1B	NAAF-7474-1B,Power amplifier PC board ass'y <O>		1A929591-1F	NAETC-7491-1F,PC board for holder <K>
U16	1A929575-1A	NAETC-7475-1A, Speaker terminal PC board ass'y <D>	U32	1A929592-1A	NAETC-7492-1A,PC board for holder <D>
	1A929575-1B	NAETC-7475-1B, Speaker terminal PC board ass'y <O>		1A929592-1B	NAETC-7492-1B,PC board for holder <P>
U17	1A929577-1A	NAPS-7477-1A,Secondary circuit PC board ass'y <D>		1A929592-1C	NAETC-7492-1C,PC board for holder <A>
	1A929577-1B	NAPS-7477-1B,Secondary circuit PC board ass'y <O>		1A929592-1D	NAETC-7492-1D,PC board for holder <R>
U19	1A929579-1A	NAETC-7479-1A,PC board for holder <D>		1A929592-1E	NAETC-7492-1E,PC board for holder <T/Q>
	1A929579-1B	NAETC-7479-1B,PC board for holder <O>		1A929592-1F	NAETC-7492-1F,PC board for holder <K>
U20	1A929580-1A	NAETC-7480-1A,Thermal detector PC board ass'y <D>	U33	1A929593-1F	NAAF-7483-1F,AC outlet terminal PC board ass'y <K>
	1A929580-1B	NAETC-7480-1B,Thermal detector PC board ass'y <O>	U36	240138A,	ENG06501QR,
U21	1A929581-1A	NAETC-7481-1A,PC board for holder <D>		240134A or	TFCE1U114B or
	1A929581-1B	NAETC-7481-1B,PC board for holder <O>		240141	FAE350-A13F,Tuner pack <D>
U23	1A929583-1A	NAAF-7483-1A,Driver circuit PC board ass'y <D>		240139A,	ENG07501QR,
	1A929583-1B	NAAF-7483-1B,Driver circuit PC board ass'y <P>		240135 or	TFCE1E512A or
	1A929583-1C	NAAF-7483-1C,Driver circuit PC board ass'y <A>		240142	FAE404-E13F,Tuner pack <O>
	1A929583-1D	NAAF-7483-1D,Driver circuit PC board ass'y <R>			
	1A929583-1E	NAAF-7483-1E,Driver circuit PC board ass'y <T/Q>			
U24	1A929584-1A	NAPS-7484-1A,Primary circuit PC board ass'y <D>			
	1A929584-1B	NAPS-7484-1B,Primary circuit PC board ass'y <P>			
	1A929584-1C	NAPS-7484-1C,Primary circuit PC board ass'y <A>			
	1A929584-1D	NAPS-7484-1D,Primary circuit PC board ass'y <R>			
	1A929584-1E	NAPS-7484-1E,Primary circuit PC board ass'y <T/Q>			
	1A929584-1F	NAPS-7484-1F,Primary circuit PC board ass'y <K>			
U26	1A929586-1A	NAETC-7486-1A,Connector PC board ass'y <D>			
	1A929586-1B	NAETC-7486-1B,Connector PC board ass'y <P>			
	1A929586-1C	NAETC-7486-1C,Connector PC board ass'y <A>			
	1A929586-1D	NAETC-7486-1D,Connector PC board ass'y <R>			
	1A929586-1E	NAETC-7486-1E,Connector PC board ass'y <T/Q>			
	1A929586-1F	NAETC-7486-1F,Connector PC board ass'y <K>			

A **B** **C** **D**

BLOCK DIAGRAM 2

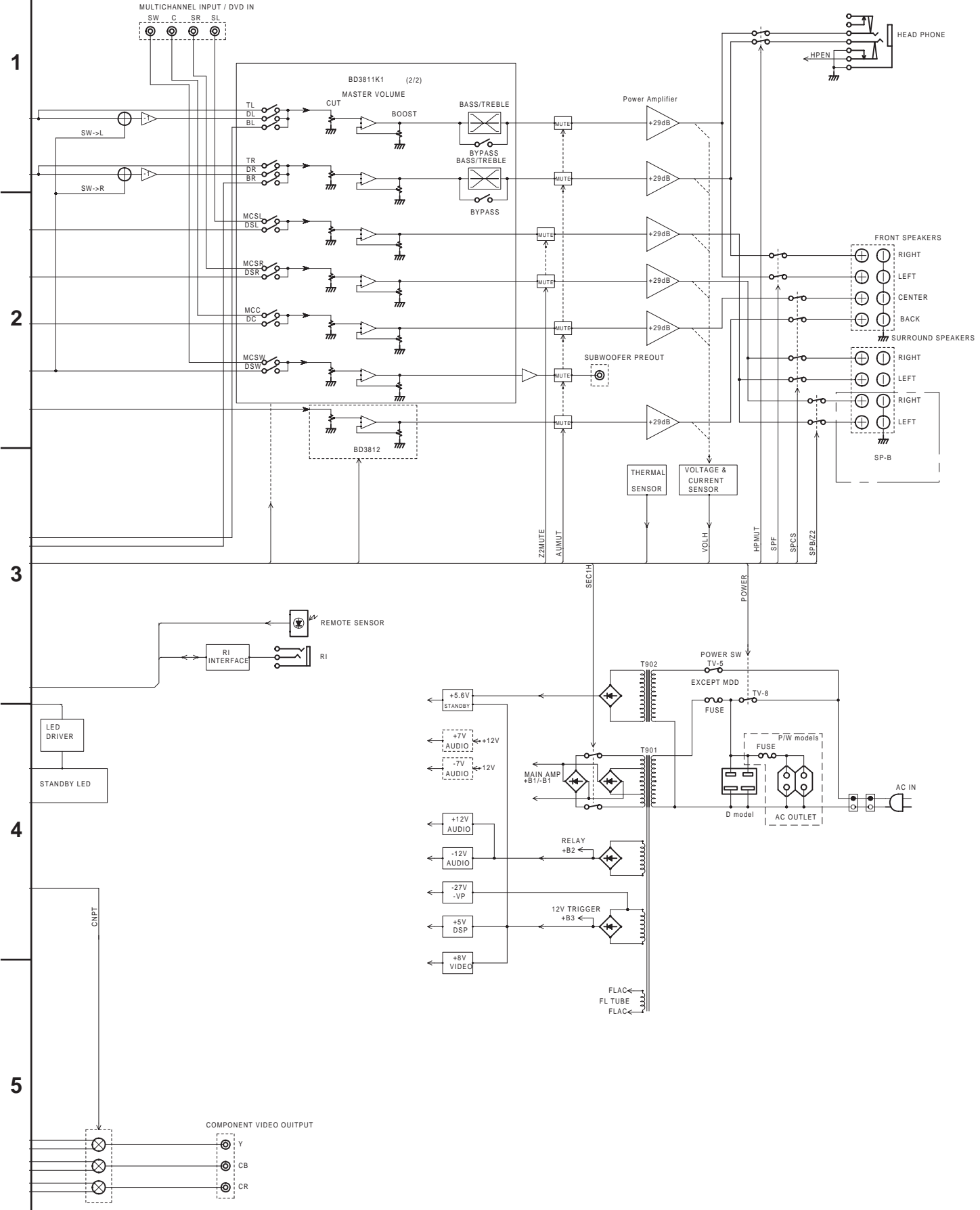

SCHEMATIC DIAGRAM 1-1

Display section

1
2
3
4
5

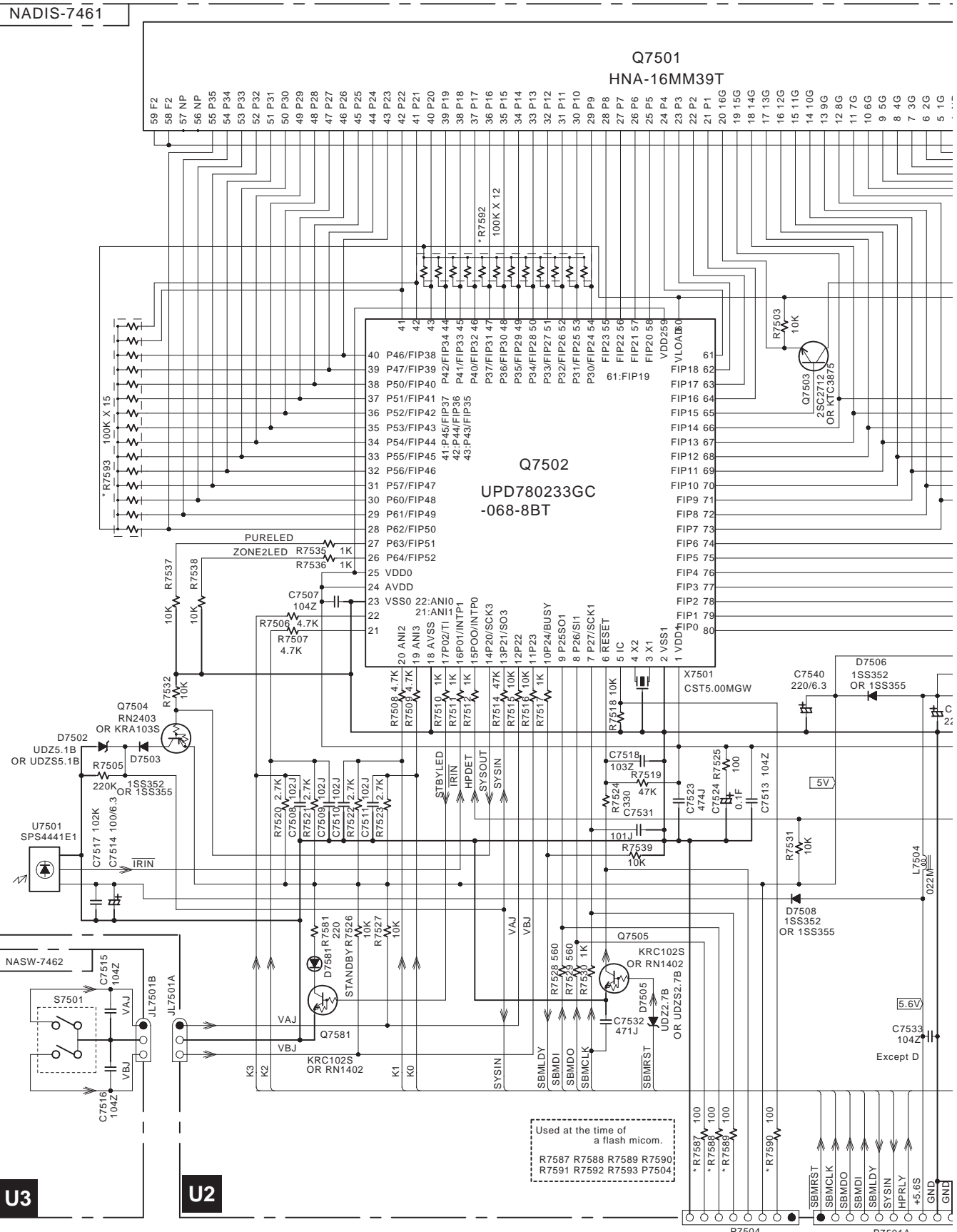

Used at the time of a flash microm.
 R7587 R7588 R7589 R7590
 R7591 R7592 R7593 P7504

U3

U2

SCHEMATIC DIAGRAM 1-2

Display section

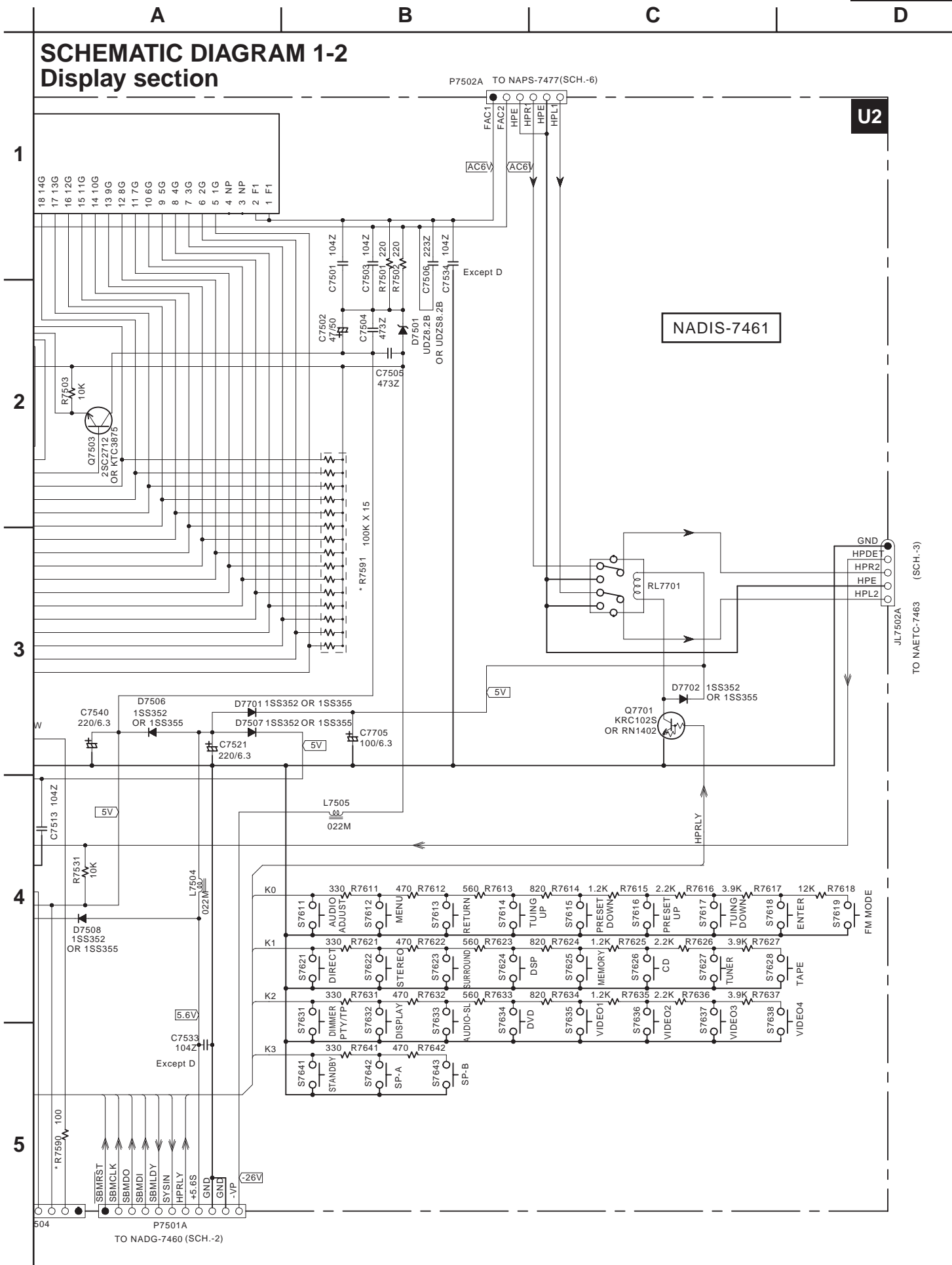

SCHEMATIC DIAGRAM 2-1 DSP section

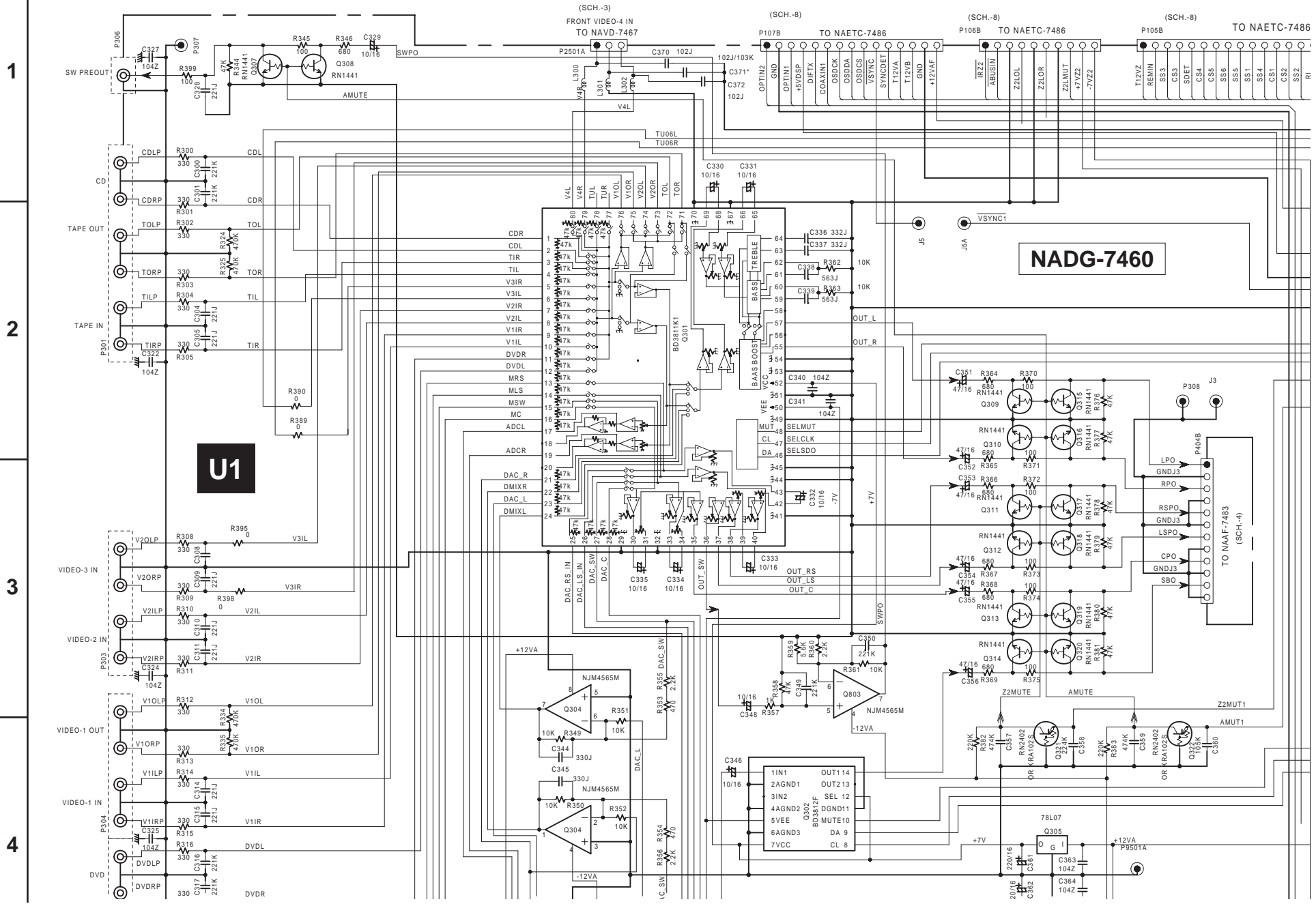

SCHEMATIC DIAGRAM 2-2 DSP section

1

2

3

4

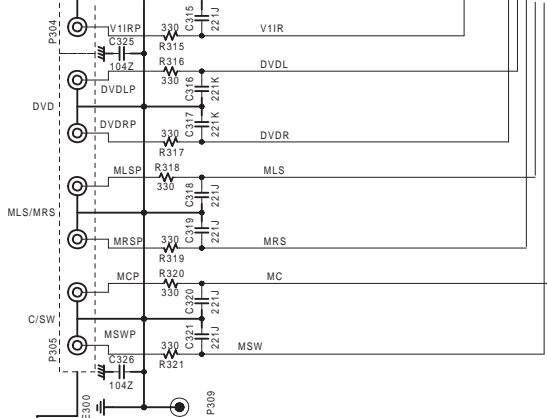

NADG-7460

REGION	A	B	C	D
U.S.A.	Europe	Australia /Korean	Asia	
C181	-	YES	-	-
C182	-	YES	-	-
C183	-	YES	-	-
C184	-	YES	-	-
C185	-	YES	-	-
C186	-	YES	-	-
C187	-	YES	-	-
C371	102J	103K	103K	102J
L181	-	YES	-	-
Q101	-	YES	-	-
Q181	-	YES	-	-
R104	-	YES	-	-
R105	-	YES	-	-
R181	-	YES	-	-
R182	-	YES	-	-
R183	-	YES	-	-
R184	-	YES	-	-
R7055	YES	-	YES	YES
R7056	-	YES	-	-
R7057	YES	-	-	-
R7058	-	YES	YES	YES
R7059	YES	-	-	-
R7060	-	YES	YES	YES
R7061	YES	-	-	YES
R7062	-	YES	YES	-
X181	-	YES	-	-

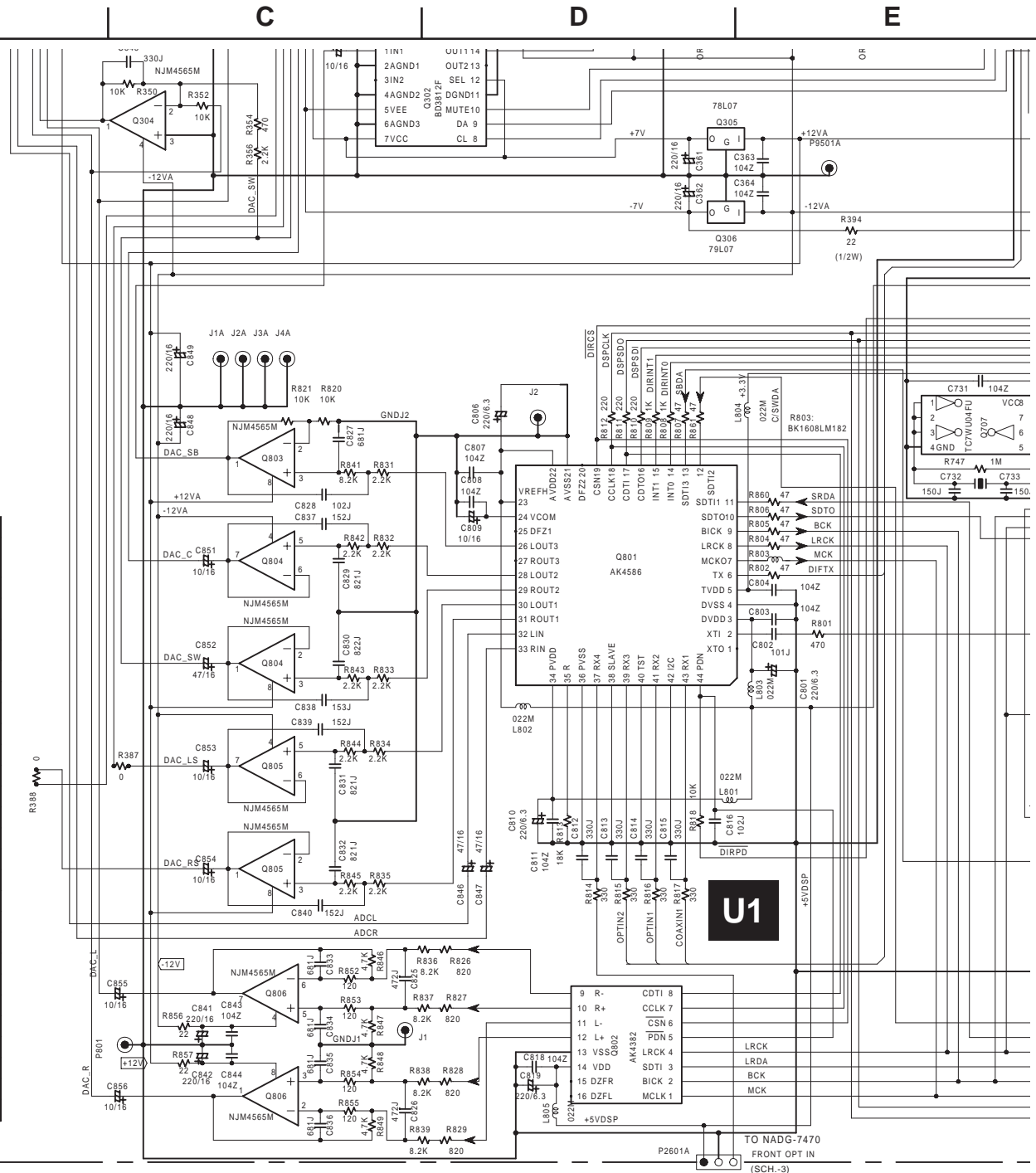

U1

TO NADG-7470
FRONT OPT IN
(SCH.-3)

A

B

C

D

E

SCHEMATIC DIAGRAM 2-3 DSP section

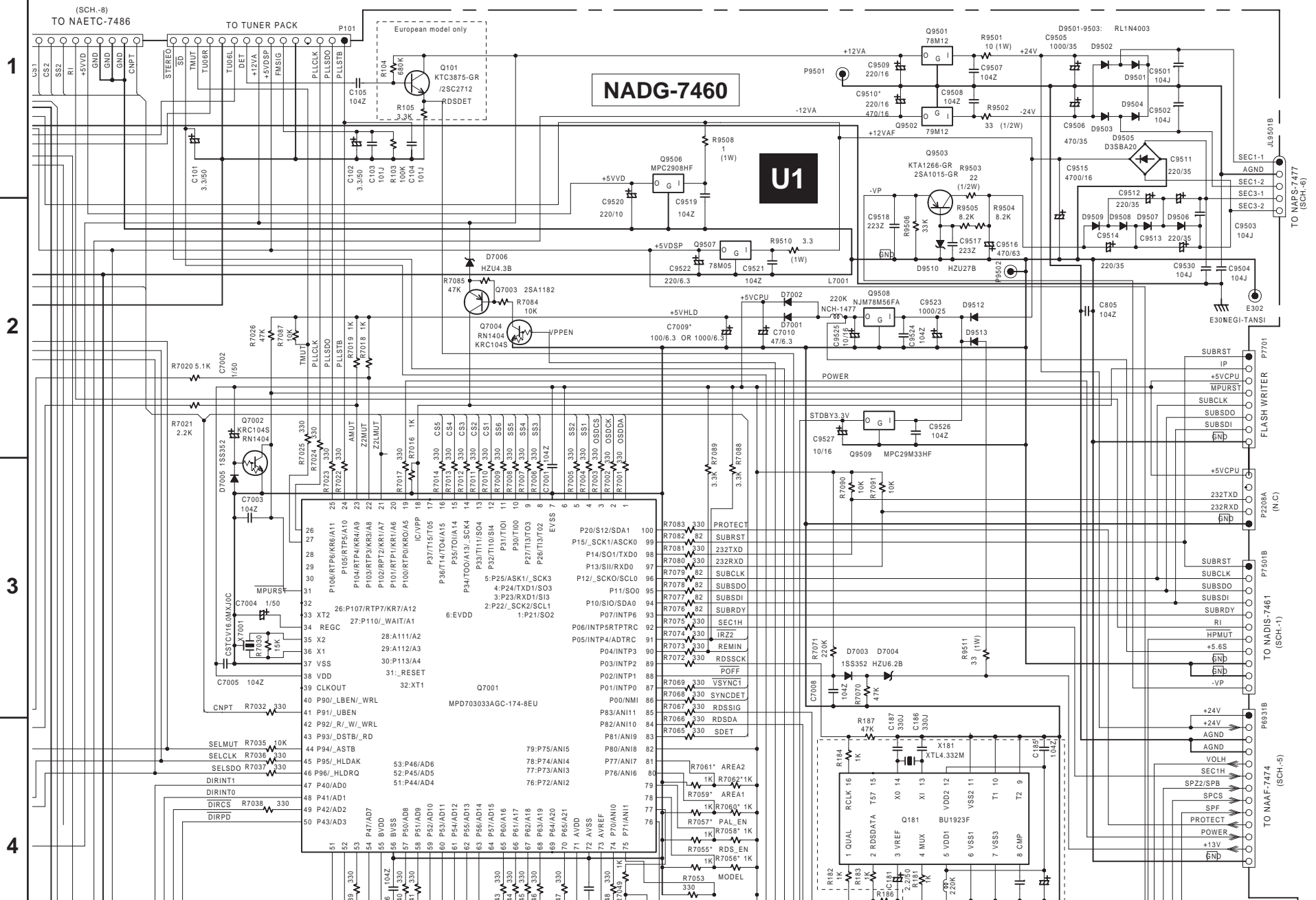

1

2

3

4

SCHEMATIC DIAGRAM 2-4 DSP section

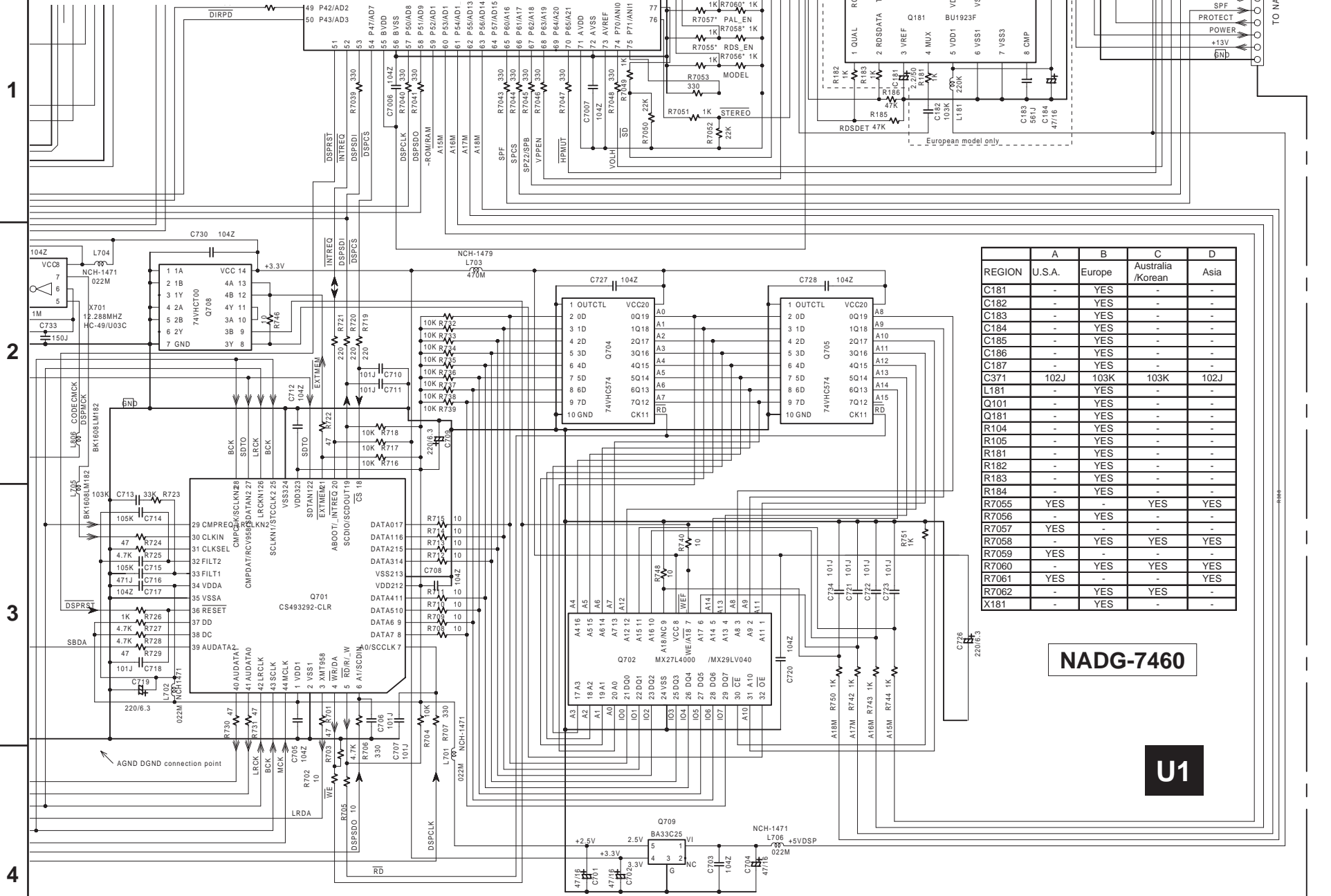

REGION	A	B	C	D
C181	-	YES	-	-
C182	-	YES	-	-
C183	-	YES	-	-
C184	-	YES	-	-
C185	-	YES	-	-
C186	-	YES	-	-
C187	-	YES	-	-
C371	102J	103K	103K	102J
L181	-	YES	-	-
Q101	-	YES	-	-
Q181	-	YES	-	-
R104	-	YES	-	-
R105	-	YES	-	-
R181	-	YES	-	-
R182	-	YES	-	-
R183	-	YES	-	-
R184	-	YES	-	-
R7055	YES	-	YES	YES
R7056	-	YES	-	-
R7057	YES	-	-	-
R7058	-	YES	YES	YES
R7059	YES	-	YES	-
R7061	YES	-	YES	YES
R7062	-	YES	YES	-
X181	-	YES	-	-

NADG-7460

U1

A B C D

SCHEMATIC DIAGRAM 3

1

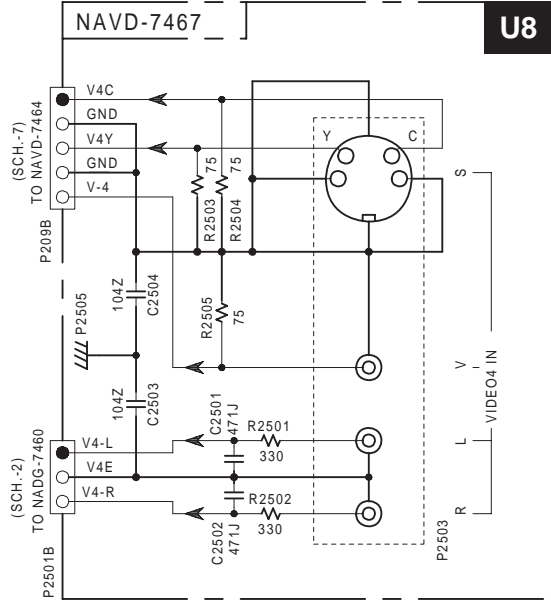

2

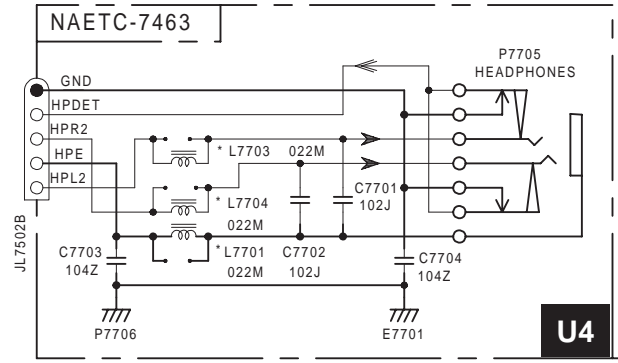

3

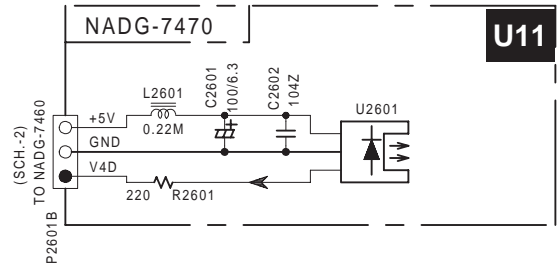

4

5

A B C D

SCHEMATIC DIAGRAM 4-1
Power amplifier section 1

1

2

3

4

5

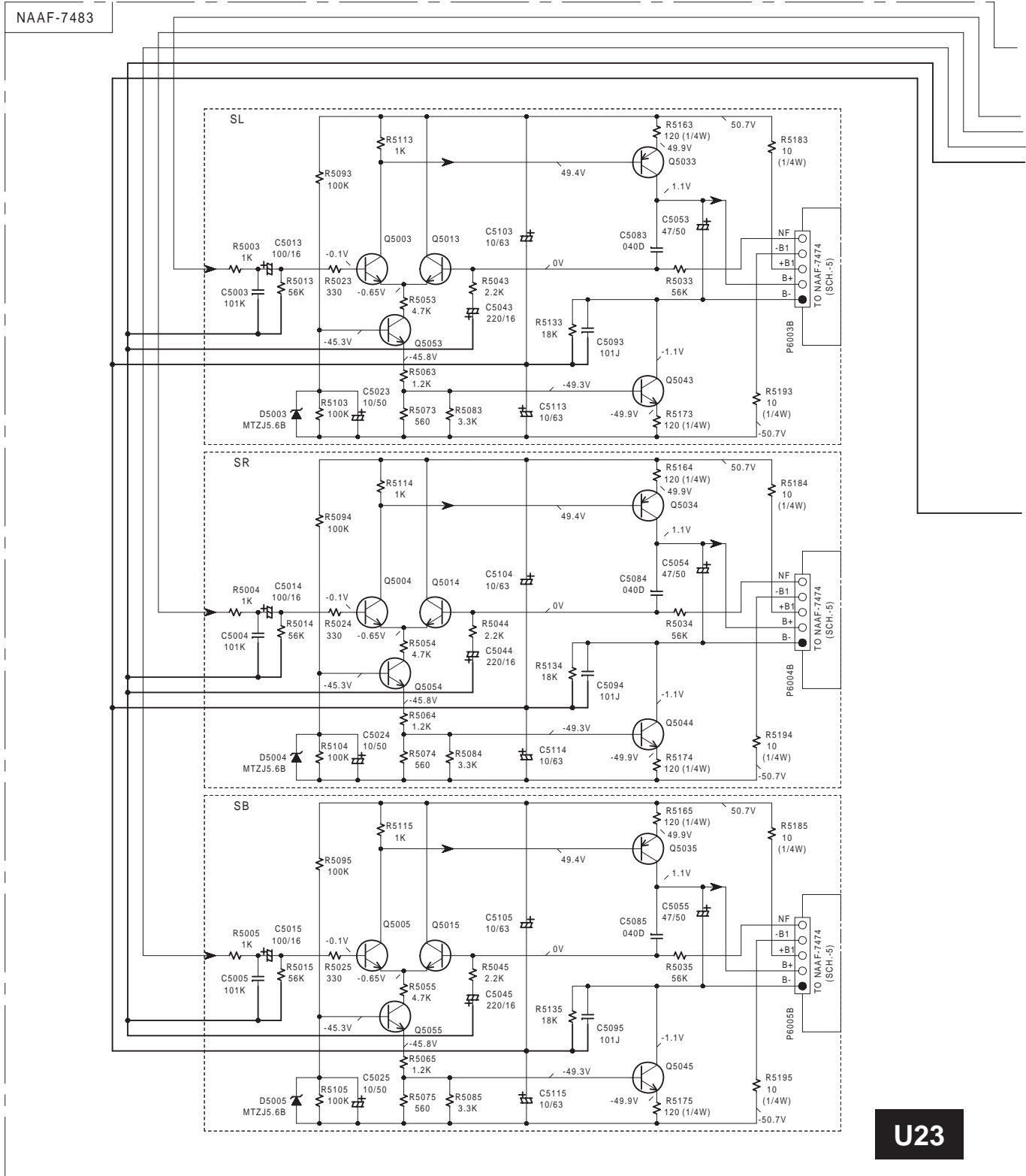

U23

SEMICONDUCTORS			
NO.	L / R / C	NO.	SL / SR / SB
Q5000-02, 5010-12	2SC1775A-E, F OR 2SC1845-E	Q5003-05, 5013-15	KTC3200-BL OR 2SC1775A-E, F OR 2SC1845-E, F
Q5020-22	2SA992-E, F	Q5023-25	2SA992-E, F
Q5030-32	2SA949-Y, O	Q5033-35	KTA1024-Y, O OR 2SA949-Y, O
Q5040-42	2SC2229-Y, O	Q5043-45	KTC3206-Y, O OR 2SC2229-Y, O

A B C D
SCHEMATIC DIAGRAM 6-1 Power supply section

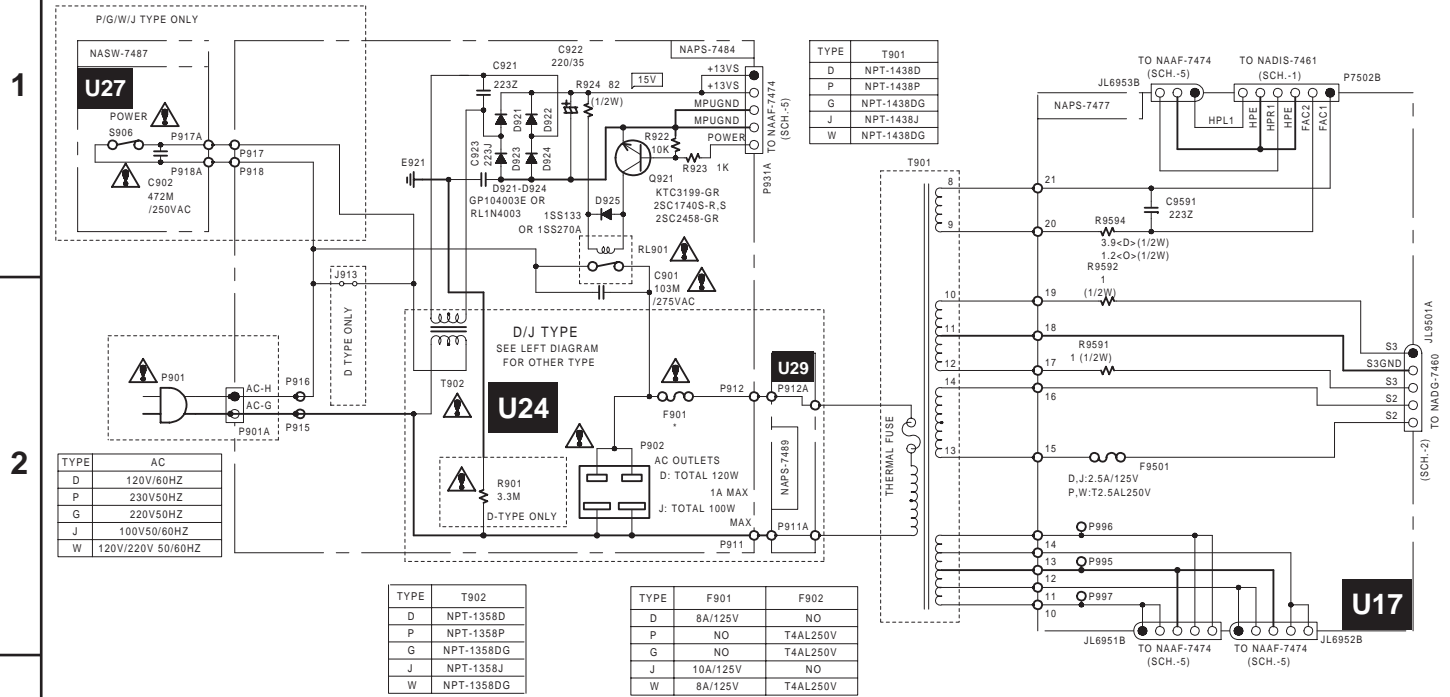

NOTE

- THE COMPONENTS IDENTIFIED BY MARK ARE CRITICAL FOR SAFETY. REPLACE ONLY WITH PART NUMBER SPECIFIED.
- VOLTAGE (MEASURED WITH VOLTMETER) IS DC VOLTAGE. (NO INPUT SIGNAL)
- ELECTROLYTIC CAPACITORS () ARE IN uF/WV.
- ALL CAPACITORS ARE IN pF/50WV UNLESS OTHERWISE NOTED.
EX) 030 → 3pF 330 → 33pF 331 → 330pF 333 → 0.033uF
- ALL RESISTORS ARE IN OHMS 1/6 WATTS UNLESS OTHERWISE NOTED.
- CIRCUIT IS SUBJECT TO CHANGE FOR IMPROVEMENT.

THIS SYMBOL LOCATED NEAR THE FUSE INDICATES THAT THE FUSE USED IS SLOW OPERATING TYPE FOR CONTINUED PROTECTION AGAINST FIRE HAZARD. REFER TO THE MARKING ADJACENT TO THE SYMBOL

CE SYMBOLE INDIQUE QUE LE FUSIBLE UTILISE EST LENT. POUR UNE PROTECTION PERMANENTE, N'UTILISER QUE DES FUSIBLES DE MEME TYPE. CE DERNIER EST INDIQUE LA QU LE PRESENT SYMBOLE EST APPOSE.

CAUTION
 FOR CONTINUED PROTECTION AGAINST FIRE HAZARD, REPLACE ONLY WITH FUSE OF SAME TYPE AND RATING INDICATED.

ATTENTION
 AFIN D'ASSURER UNE PROTECTION PERMANENTE CONTRE LES RISQUES D'INCENDIE, REMPLACER UNIQUEMENT PAR UN FUSIBLE DE MEME TYPE ET CALIBRATION COMME INDIQUE.

SCHEMATIC DIAGRAM 6-2 Speaker terminal section

1
2
3
4
5

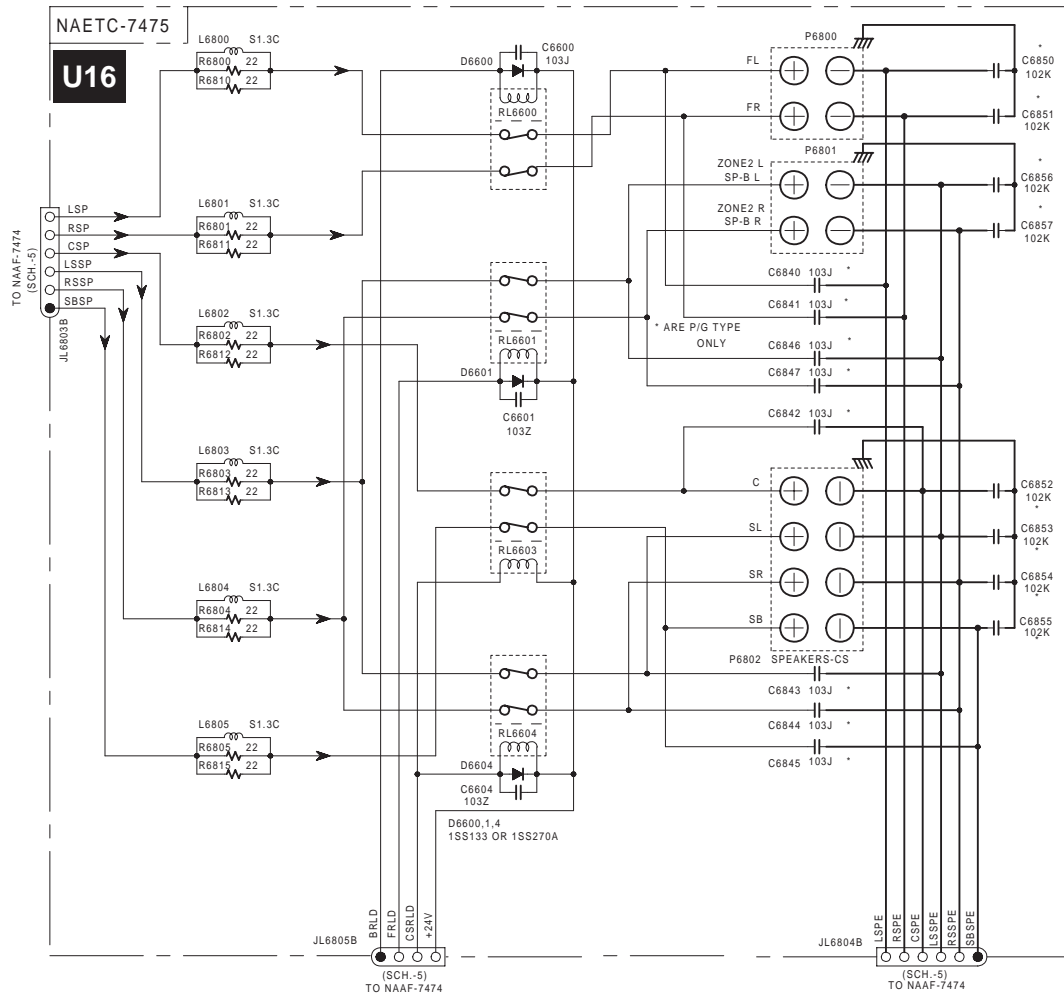

A

B

C

D

SCHEMATIC DIAGRAM 8
Connector section

U26

1

2

3

4

5

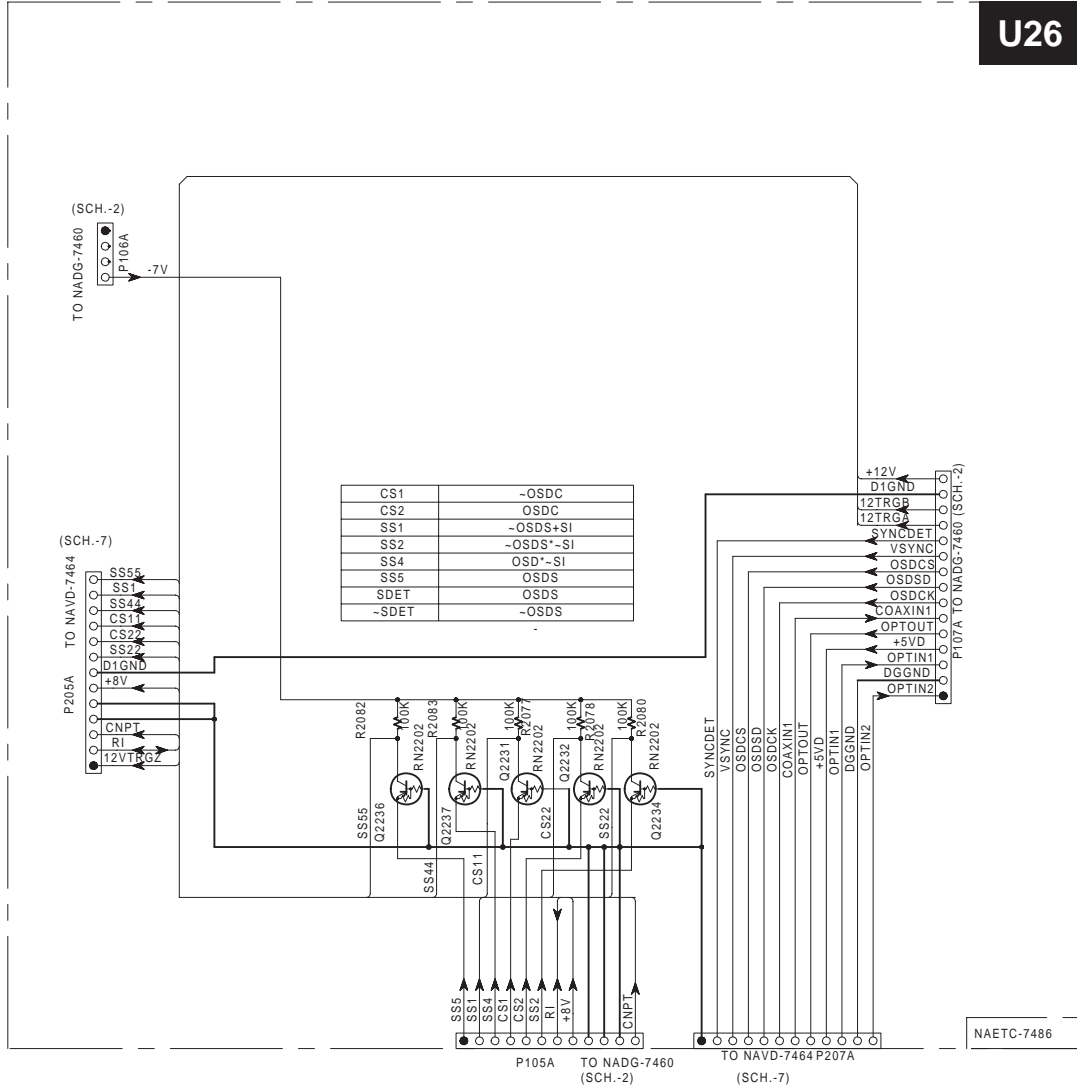

A B C D

WIRING VIEW 1

1

2

3

4

5

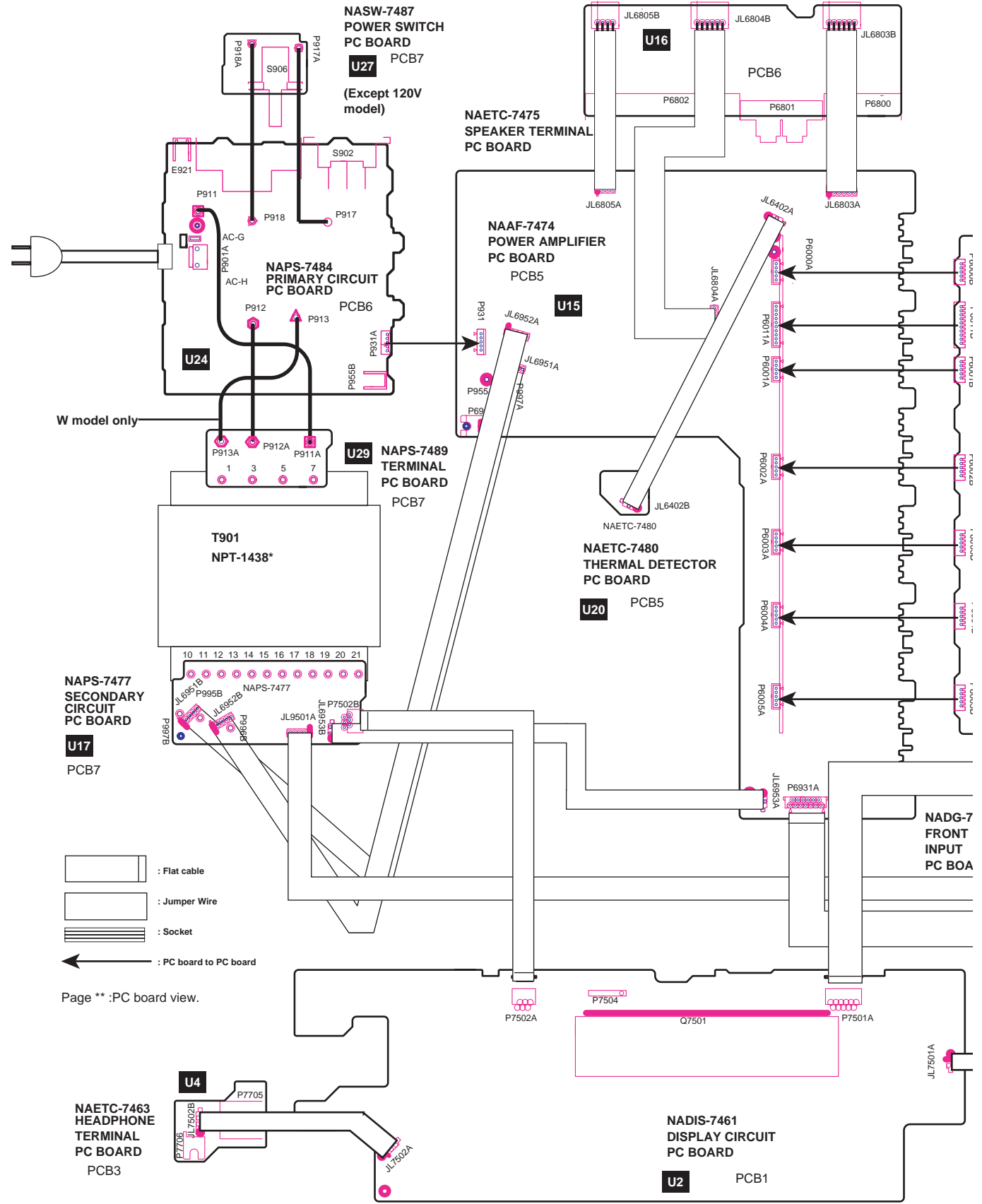

W model only

Page **:PC board view.

A B C D

WIRING VIEW 2

1

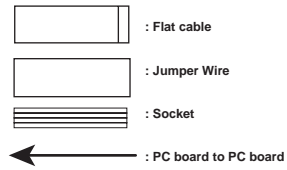

PCB* :PC board view.

2

3

4

5

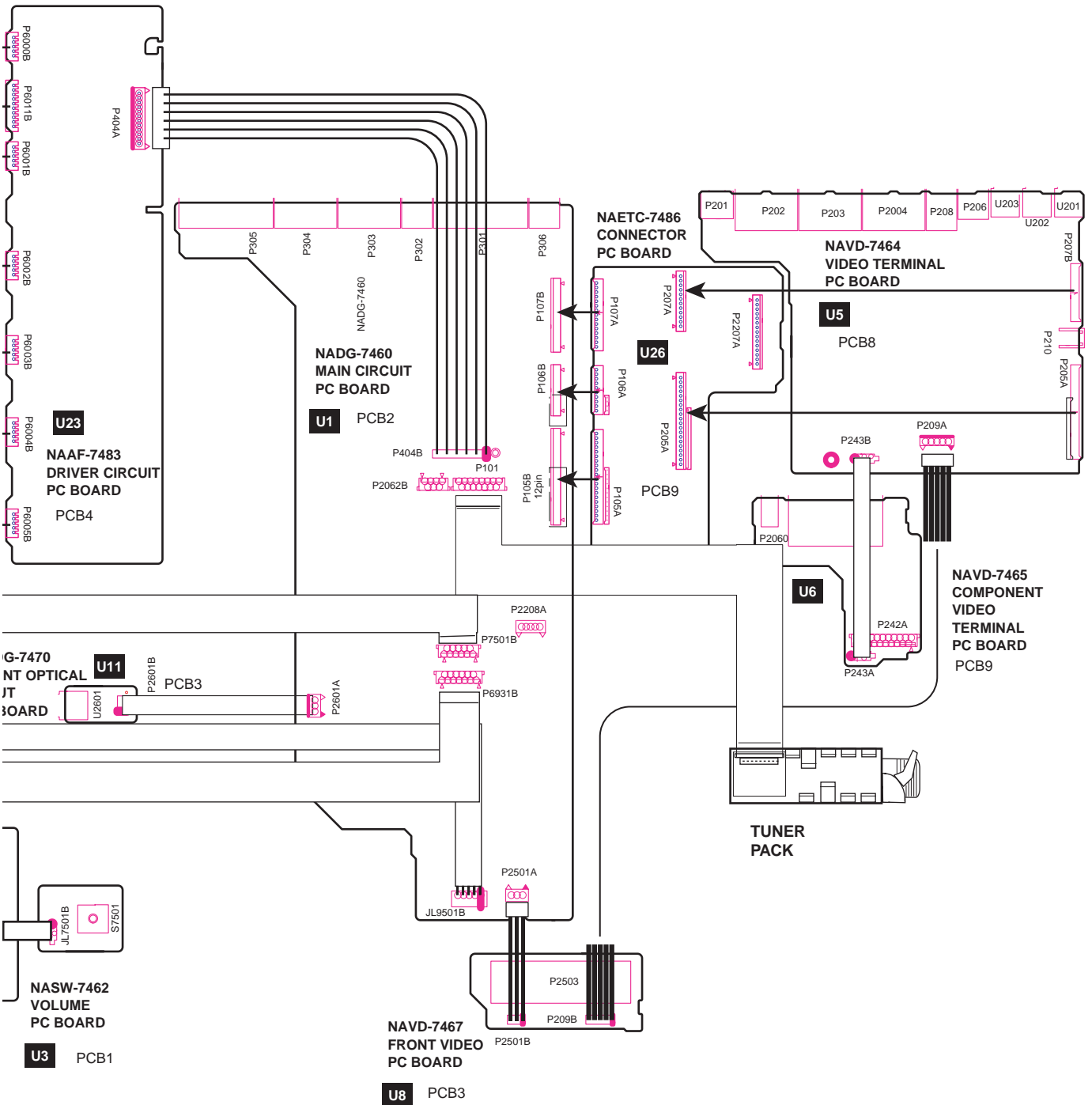

PC BOARD-CONNECTION VIEW 1

1
2
3
4
5

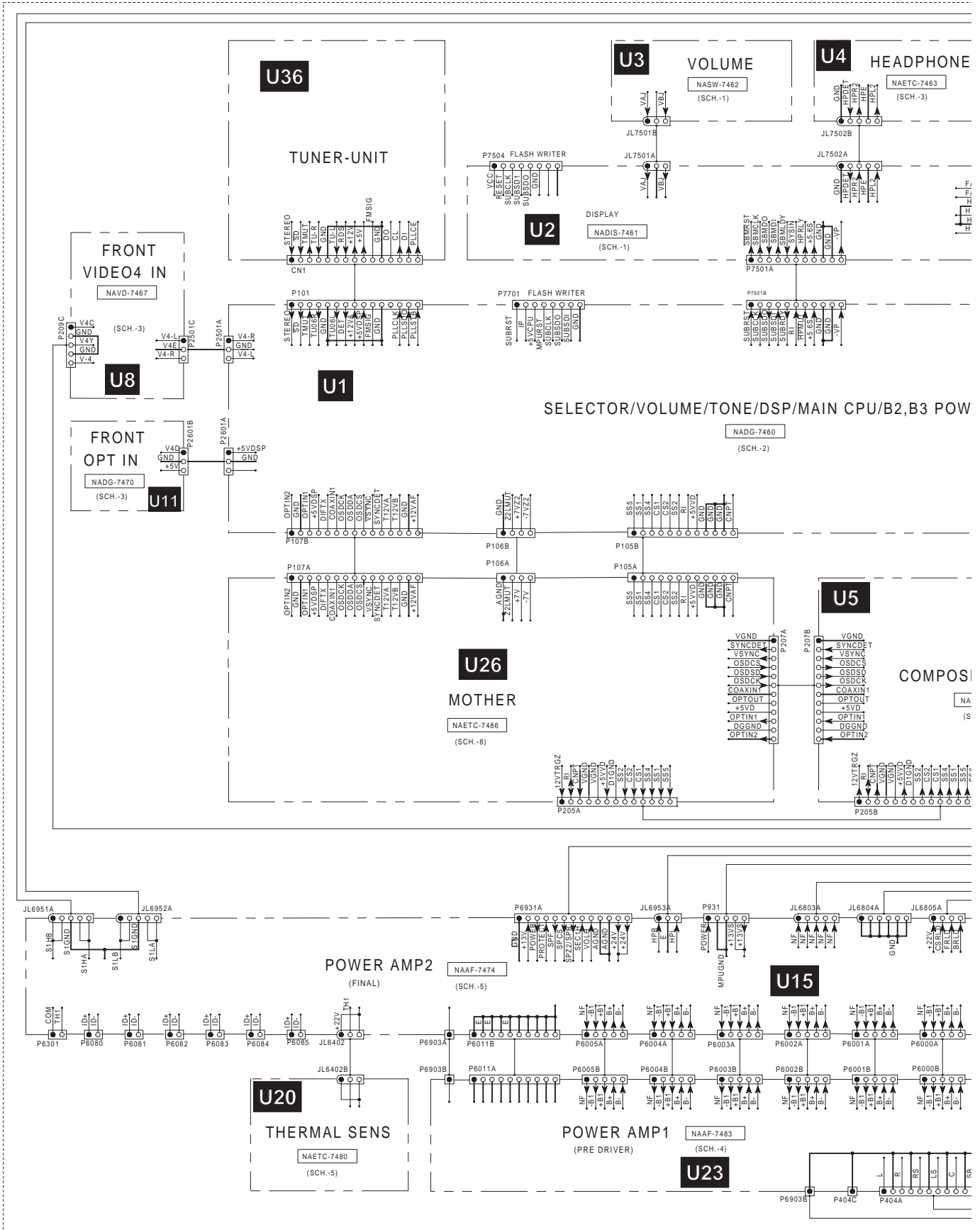

U36
TUNER-UNIT

U3 VOLUME
NASW-7462 (SCH.-1)

U4 HEADPHONE
NAETC-7463 (SCH.-3)

U2 DISPLAY
NADIS-7461 (SCH.-1)

FRONT VIDEO4 IN
NAVD-7467 (SCH.-3)

FRONT OPT IN
NADG-7470 (SCH.-3)

U1

SELECTOR/VOLUME/TONE/DSP/MAIN CPU/B2,B3 POW
NADG-7460 (SCH.-2)

U26 MOTHER
NAETC-7486 (SCH.-8)

U5 COMPOS

POWER AMP2 (FINAL)
NAAF-7474 (SCH.-5)

U20 THERMAL SENS
NAETC-7480 (SCH.-5)

POWER AMP1 (PRE DRIVER)
NAAF-7483 (SCH.-4)

U23

U15

A B C D

PC BOARD-CONNECTION VIEW 2

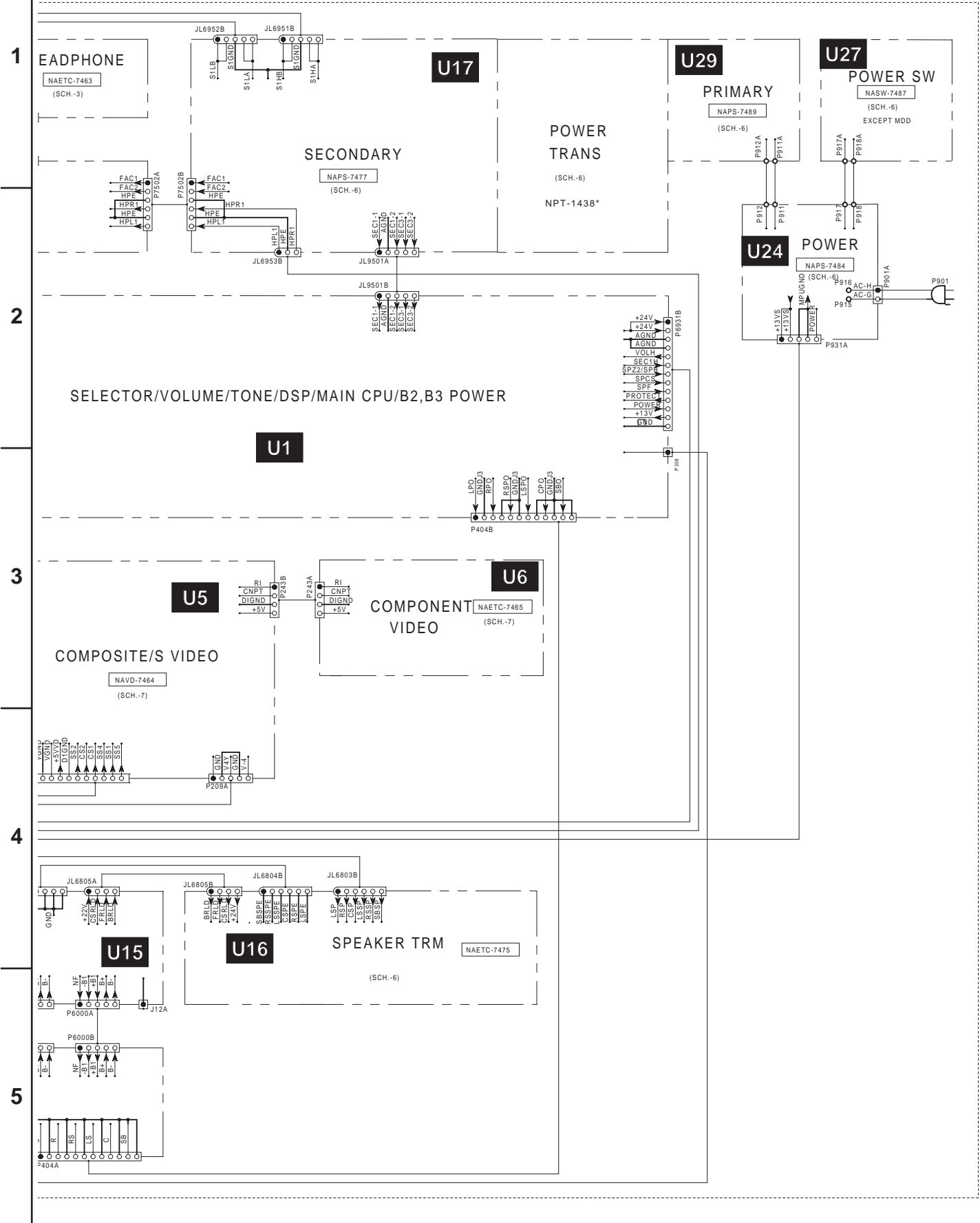

PRINTED CIRCUIT BOARD-PARTS LIST 1

<D>: 120V model only
<P>: European model only
<O>: Except 120V model

MAIN CIRCUIT PC BOARD (NADG-7460-1A/1B/1C/1D)			CIRCUIT NO.	PART NO.	DESCRIPTION
CIRCUIT NO.	PART NO.	DESCRIPTION			
		ICs			
Q181	22241297R2	BU1923F <P>	L181	231237K220R2	NCH-1477 <P>
Q301	22241761R3	BD3811K1	L300~L302	230955R2	BK1608HS102-T
Q302	22241785R2	BD3812F	L7001	231237K220R2	NCH-1477
Q304	22241383R2,	NJM4565M-D,	L701,L702	231237M022R2	NCH-1471
	22240489R1NE or	MPC4570G2-T1(MST) or	L703	231237K470R2	NCH-1479
	22240581R2	NJM4565M	L704,L706	231237M022R2	NCH-1471
Q305	222780073R2	78L07	L705	230958R1	BK1608LM182-T
Q306	222790073R2	79L07	L801~L805	231237M022R2	NCH-1471
Q7001	22241870R3	MPD703033AGC-174-8EU	L806	230958R1	BK1608LM182-T
Q701	22241788R2	CS493292-CLR			Capacitors
Q702	22241795R3 or	MX27L2000(TX-SR600) or	C101,C102	394680337	3.3uF,50V,Elect.
	22241817R3	MX27L4000TC-20(TXSR600)	C181	394680227	2.2uF,50V,Elect. <P>
Q704,Q705	22274574ER2TO,	TC74VHC574FT,	C183	374725614	560pF+/-5%,50V,Plastic <P>
	22274574ER2ST or	M74VHC574TTR or	C184	394644707	47uF,16V,Elect. <P>
	22274574IR2T1	SN74AHC574PWR	C300,C301	374722215	220pF+/-10%,50V,Plastic
Q707	22240935R2	TC7WU04FU	C316,C317	374722215	220pF+/-10%,50V,Plastic
Q709	22241778R2	BA33C25FP	C329~C335	393341007	10uF,16V,Elect.
Q801	22241620R3	AK4586	C336,C337	374723324	3300pF+/-5%,50V,Plastic
Q802	22241784R2	AK4382A	C338,C339	374725634	0.056uF+/-5%,50V,Plastic
Q803~Q806	22241383R2,	NJM4565M-D,	C346,C348	393341007	10uF,16V,Elect.
	22240489R1NE or	MPC4570G2-T1(MST) or	C349,C350	374722215	220pF+/-10%,50V,Plastic
	22240581R2	NJM4565M	C351~C356	393344707	47uF,16V,Elect.
Q9501	222780125	78M12HF	C361,C362	394642217	220uF,16V,Elect.
Q9502	222790125	79M12HF	C7002,C7004	394680107	1uF,50V,Elect.
Q9506	22278008DNE	MPC2908HF	C7009	394621017	100uF,6.3V,Elect. <D>
Q9507	222780055	78M05HF		394621027	1000uF,6.3V,Elect. <O>
Q9508	222780565JRC	NJM78M56FA	C701,C702	394644707	47uF,16V,Elect.
Q9509	22278033ENE	MPC29M33HF	C7010	394624707	47uF,6.3V,Elect.
		Transistors	C704	394644707	47uF,16V,Elect.
Q101	2216175R2 or	KTC3875-GR or	C709,C719	394622217	220uF,6.3V,Elect.
	2213145R2	2SC2712-GR <P>	C726	394622217	220uF,6.3V,Elect.
Q307~Q320	2215410R2	RN1441	C801,C806	394622217	220uF,6.3V,Elect.
Q321,Q322	2216220R2 or	KRA102S or	C809	394641007	10uF,16V,Elect.
	2214530R2	RN2402	C810,C819	394622217	220uF,6.3V,Elect.
Q7002	2216210R2 or	KRC104S or	C825,C826	374724724	4700pF+/-5%,50V,Plastic
	2214490R2	RN1404	C827	374726814	680pF+/-5%,50V,Plastic
Q9503	2215975 or	KTA1266-GR or	C828	374721024	1000pF+/-5%,50V,Plastic
	2211455	2SA1015-GR	C829,C830	374728214	820pF+/-5%,50V,Plastic
		Diodes	C831,C832	374728214	820pF+/-5%,50V,Plastic
D7001~D7003	223234R2 or	1SS352 or	C833~C836	374726814	680pF+/-5%,50V,Plastic
D7005	223269R2	1SS355	C837	374721524	1500pF+/-5%,50V,Plastic
D7004	224660624R2,	HZU6.2B,	C838	374721534	0.015uF+/-5%,50V,Plastic
	224490620R2 or	UDZ6.2B or	C839,C840	374721524	1500pF+/-5%,50V,Plastic
	224550620R2	UDZS6.2B	C841,C842	394642217	220uF,16V,Elect.
D9501~D9504	22380260,	RL1N4003,	C846,C847	393344707	47uF,16V,Elect.
D9506~D9509	22380032 or	1SR139-100 or	C848,C849	394642217	220uF,16V,Elect.
	22380035	GP104003E	C851	393341007	10uF,16V,Elect.
D9505	22380271F,	D3SBA20,	C852	393344707	47uF,16V,Elect.
	22380022F or	RBV402 or	C853~C856	393341007	10uF,16V,Elect.
	22380285F	RS403M	C9501~C9504	374721044	0.1uF+/-5%,50V,Plastic
D9510	224662704R2 or	HZU27B or	C9505	394661027	1000uF,35V,Elect.
	224552700R2	UDZS27B	C9506	394664717	470uF,35V,Elect.
D9512,D9513	223234R2 or	1SS352 or	C9509	394642217	220uF,16V,Elect.
	223269R2	1SS355	C9510	394642217	220uF,16V,Elect.<D>
		Oscillators		394644717	470uF,16V,Elect.<O>
X181	3010345 or	HQS-3H2-04332-20 or	C9511~C9514	394562217	220uF,35V,Elect.
	3010203	AF6146CG,Crystal <P>	C9515	394544727	4700uF,16V,Elect.
X7001	3010329R2	CSTCV16.00MXJ0C,Ceramic	C9516	394674717	470uF,63V,Elect.
X701	3010335 or	AT-49H12.288MHz or	C9520	394632217	220uF,10V,Elect.
	3010327	AT-49I2.288MHz,Crystal	C9522	394622217	220uF,6.3V,Elect.
			C9523	394651027	1000uF,25V,Elect.
			C9525,C9527	394641007	10uF,16V,Elect.
			C9530	374721044	0.1uF+/-5%,50V,Plastic

PRINTED CIRCUIT BOARD-PARTS LIST 2

CIRCUIT NO.	PART NO.	DESCRIPTION	CIRCUIT NO.	PART NO.	DESCRIPTION
	Resistors			Diodes	
R394	443522204	22ohm+/-5%,1/2W,Metal oxide	D7501	224490820R2,	UDZ8.2B,
R9501	442621004F	10ohm+/-5%,1W,Metal oxide		224550820R2 or	UDZS8.2B or
R9502	443523304	33ohm+/-5%,1/2W,Metal oxide		224660824R2	HZU8.2B
R9503	443522204	22ohm+/-5%,1/2W,Metal oxide	D7502	224490510R2,	UDZ5.1B,
R9510	452630334F	3.3ohm+/-5%,1W,Metal		224550510R2 or	UDZS5.1B or
R9511	442623304F	33ohm+/-5%,1W,Metal oxide		224660514R2	HZU5.1B
	Terminals		D7503	223234R2 or	1SS352 or
P301	25045571 or	NPJ-6PDRW386 or	D7506~D7508	223269R2	1SS355
	25045300	NPJ-6PDBL159	D7505	224490270R2 or	UDZ2.7B or
P303,P304	25045303 or	NPJ-4PDBL162 or		224660274R2	HZU2.7B
	25045575	NPJ-4PDRW389	D7581	225290	SEL4110R
P305	25045572 or	NPJ-6PDBRW387 or	D7701,D7702	223234R2 or	1SS352 or
	25045649	NPJ-6PDBRW453		223269R2	1SS355
P306	25045567	NPJ-1PDBL382		Coils	
	Sockets		L7504,L7505	231237M022R2	NCH-1471
JL9501B	25050269	NSCT-5P97		Oscillator	
P101	25052211 or	NSCT-15P2108 or	X7501	3010242	CST5.00MGW,Ceramic
	25051822	NSCT-15P1609		Capacitors	
P404B	2009990718UL	NSAS-26P1005	C7502	394684707	47uF,50V,Elect.
P6931B	25052209 or	NSCT-13P2106 or	C7514	394621017	100uF,6.3V,Elect.
	25051820	NSCT-13P1607	C7521	394622217	220uF,6.3V,Elect.
P7501B	25052207 or	NSCT-11P2104 or	C7523	375524744	0.47uF+/-5%,50V,Plastic
	25051818	NSCT-11P1605	C7524	3000120 or	FMC0H104Z or
	Plugs			3000121	SCDA5R5104A,Super
P105B	25055708	NPLG-12P664	C7540	355722219	220uF,6.3V,Elect.
P106B	25055804	NPLG-4P760	C7705	394621017	100uF,6.3V,Elect.
P107B	25055711	NPLG-15P667		Relay	
P2208A	25055701	NPLG-5P657	RL7701	25065610	NRL-2P1A-DC4.5-156
P2501A,P2601A	25055133	NPLG-3P117		Switches	
	Heat sink		S7611~S7618	25035699 or	NPS-111-S662 or
Q9501B	27160500	RAD-165	S7621~S7624	25035714	NPS-111-S677
	Cushions		S7619,S7625	25035699 or	NPS-111-S662 or
Q801A,Q802A	28141445	(DAC)		25035714	NPS-111-S677
	Screws		S7626~S7628	25035699 or	NPS-111-S662 or
Q9501A	82143010	3P+10FN(BC),Pan head	S7631~S7638	25035714	NPS-111-S677
Q9506A~Q9508A	82143010	3P+10FN(BC),Pan head	S7644~S7647	25035714	NPS-111-S677
			S7641~S7643	25035699 or	NPS-111-S662 or
				25035714	NPS-111-S677
	DISPLAY CIRCUIT PC BOARD (NADIS-7461-1A/1B)			Sockets	
	CIRCUIT NO. PART NO. DESCRIPTION		JL7501A	25051087	NSCT-3P874
	FL tube		JL7502A	25051089	NSCT-5P876
Q7501	212229	HNA-16MM39T	P7501A	25052057 or	NSCT-11P1844 or
	Remote sensor			25051855	NSCT-11P1642
U7501	241341 or	SPS-444-1-E1 or	P7502A	25052052 or	NSCT-6P1839 or
	241335	SPS-444-1		25051850	NSCT-6P1637
	IC			Holder	
Q7502	22241790R3	MPD780232GC-068-8BT	Q7501A	27190989A	(FL)
	Transistors			VOLUME PC BOARD (NASW-7462-1A/1B)	
Q7503	2216175R2 or	KTC3875-GR or		CIRCUIT NO. PART NO. DESCRIPTION	
	2213145R2	2SC2712-GR	S7501	25065627	EC12E2425,Rotary encoder
Q7504	2216230R2 or	KRA103S or	JL7501B	25051087	NSCT-3P874,Socket
	2214540R2	RN2403		HEADPHONE TERMINAL PC BOARD (NAETC-7463-1A/1B)	
Q7505,Q7581	2216190R2 or	KRC102S or		CIRCUIT NO. PART NO. DESCRIPTION	
Q7701	2214470R2	RN1402		Coils	
			L7701	233454M022S	NCH-1452 022M
			L7703,L7704	231237M022R2	NCH-1471
				Capacitor	
			C7703	374721044	0.1uF+/-5%,50V,Plastic
				Terminal	
			P7705	25045514	YKB26-5005
				Socket	
			JL7502B	25051089	NSCT-5P876

PRINTED CIRCUIT BOARD-PARTS LIST 3

<O>: Except 120V model

VIDEO TERMINAL PC BOARD (NAVD-7464-1A/1B)

CIRCUIT NO.	PART NO.	DESCRIPTION
	ICs	
Q205	22240373	BA7625
Q210	22241779	LC74763-9836
Q211	222740046R2TO	74HCU04(TC74HCU04F)
Q259,Q260	22240373	BA7625
	Transistors	
Q201,Q202	2216031R2 or 2216032R2	RN1444-A or RN1444-B
Q203,Q204	2216185R2 or 2214375R2	KTA1504-GR or 2SA1162-GR
Q206,Q207	2216031R2 or	RN1444-A or
Q251-Q254	2216032R2	RN1444-B
Q208	2216185R2 or	KTA1504-GR or
Q255-Q258	2214375R2	2SA1162-GR
Q209	2216175R2 or 2213145R2	KTC3875-GR or 2SC2712-GR
	Photo coupler	
U201,U202	24120083 or 24120086	GP1FA550RZ or GP1FA551RZ
U203	24120082 or 24120085	GP1FA550TZ or GP1FA551TZ
	Diodes	
D201	223234R2 or 223269R2	1SS352 or 1SS355
D202-D205	224490240R2 or 224370240R2	UDZ2.4B or RD2.4SB
	Coils	
L201	231237M022R2	NCH-1471
L202	231292J056R2	NCH-1572
L203,L241	231237M022R2	NCH-1471
L243	231237M022R2	NCH-1471
	Oscillators	
X201	3010363	HC-49/U0314.318M
X202	3010364	HC-49/U0317.734M <O>
	Capacitors	
C201,C203	394624717	470uF,6.3V,Elect.
C202,C204	394680227	2.2uF,50V,Elect.
C205	394680227	2.2uF,50V,Elect.
C207,C240	394644707	47uF,16V,Elect.
C209	394641017	100uF,16V,Elect.
C214	354783399	0.33uF,50V,Elect.
C215,C223	394641017	100uF,16V,Elect.
C216	374726824	6800pF+/-5%,50V,Plastic
C217,C232	354780109	1uF,50V,Elect.
C218	374722234	0.022uF+/-5%,50V,Plastic
C221	354784799	0.47uF,50V,Elect.
C222	375524744	0.47uF+/-5%,50V,Plastic
C236	394680227	2.2uF,50V,Elect.
C243	394624717	470uF,6.3V,Elect.
C252,C256	394624717	470uF,6.3V,Elect.
C254,C258	394680227	2.2uF,50V,Elect.
C260	394680227	2.2uF,50V,Elect.
C263,C265	394644707	47uF,16V,Elect.
C268,C269	394680227	2.2uF,50V,Elect.
C270,C274	394644707	47uF,16V,Elect.
	Terminals	
P201-P203	25045681	NPJ-10PDBY478
P208	25045473	NPJ-1PDBL291
	Sockets	
P205B	25051238	NSCT-13P1028
P207B	25051237	NSCT-12P1027
P243B	25051088	NSCT-4P875
	Plug	
P209A	25055135	NPLG-5P119

COMPONENT VIDEO PC BOARD (NAVD-7465-1A/1B)

CIRCUIT NO.	PART NO.	DESCRIPTION
	Transistor	
Q241	2216175R2 or 2213145R2	KTC3875-GR or 2SC2712-GR
	Diodes	
D241	223234R2 or 223269R2	1SS352 or 1SS355
D242	224490240R2 or 224370240R2	UDZ2.4B or RD2.4SB
	Relays	
RL241,RL242	25065610	NRL-2P1A-DC4.5-156
	Terminals	
P2060	25045504	NPJ-1PDBL319
P241	25045686 or 25045690	NPJ-9PDGLR483 or NPJ-9PDGLR487
	Socket	
P243A	25051088	NSCT-4P875

FRONT VIDEO PC BOARD (NAVD-7467-1A/1B)



CIRCUIT NO.	PART NO.	DESCRIPTION
	Terminal	
P2503	25045680	NPJ-7PDB477
	Sockets	
P209B	2009990434UL	NSAS-10P0578
P2501B	2001320610	NSAS-6P0299

FRONT OPTICAL INPUT PC BOARD (NADG-7470-1A/1B/1C/1D/1N/1O/

CIRCUIT NO.	PART NO.	DESCRIPTION
	Photo coupler	
U2601	24120083 or	GP1FA550RZ or
U2601 or	24120086	GP1FA551RZ
	Coil	
L2601	231237M022R2	NCH-1471
	Capacitor	
C2601	394621017	100uF,6.3V,Elect.
	Socket	
P2601B	2009990249	NSAS-6P0362

PRINTED CIRCUIT BOARD-PARTS LIST 4

POWER AMPLIFIER PC BOARD (NAAF-7474-1A/1B)

CIRCUIT NO.	PART NO.	DESCRIPTION	CIRCUIT NO.	PART NO.	DESCRIPTION
				Capacitors	
Q6010~Q6015	2213284 or	2SC1740S-R or	C6040~C6045	394684707	47uF,50V,Elect.
Q6020~Q6025	2213285	2SC1740S-S	C6230~C6235	374724734	0.047uF+/-5%,50V,Plastic
Q6030~Q6032	2203010	2SC5171	C6701,C6706	394621017	100uF,6.3V,Elect.
Q6033~Q6035	2203434 or	KTD2061-Y or	C6704	394680107	1uF,50V,Elect.
	2203010	2SC5171	C6708	374722234	0.022uF+/-5%,50V,Plastic
Q6040~Q6042	2203000	2SA1930	C6901,C6902	3504313	12000uF,63V,Elect.
Q6043~Q6045	2203424 or	KTB1369-Y or	C6901,C6902	3504376	12000uF,63V,Elect.
	2203000	2SA1930	C6901,C6902	3504373	15000uF,71V,Elect.
Q6050~Q6052	2202823 or	* 2SC5200-O or	C6901,C6902	3504374	15000uF,71V,Elect.
	2202822	* 2SC5200-R	C6904,C6905	374733344	0.033uF+/-5%,50V,Plastic
Q6053~Q6055	2202823,	* 2SC5200-O,	C6906,C6907	374721044	0.1uF+/-5%,50V,Plastic
	2202822,	* 2SC5200-R,		Resistors	
	2203683,	* MN150S-O,	R6040~R6045	5210258	N06HR1KBC,Trimming
	2203684 or	* MN150S-Y or	R6070~R6075	415471214	120ohm+/-5%,1/4W,NF carbon
	2203686	* MN150S-P	R6080~R6085	415470224	2.2ohm+/-5%,1/4W,NF carbon
Q6060~Q6062	2202813 or	* 2SA1943-O or	R6090~R6095	415470224	2.2ohm+/-5%,1/4W,NF carbon
	2202812	* 2SA1943-R	R6100~R6105	4000201,	RF-5EGKR22,
Q6063~Q6065	2202813,	* 2SA1943-O,		4000132 or	RGC55 0.22 or
	2202812,	* 2SA1943-R,	R6230~R6235	453630824	BPR55FK0.22,Metal plate
	2203693,	* MP150S-O,	R6750,R6751	443523914	8.2ohm+/-5%,1W,Metal
	2203694 or	* MP150S-Y or		Fuse holders	390ohm+/-5%,1/2W,Metal oxide
	2203696	* MP150S-P	F6901A,F6901B	25052133	 NSCT-1P2031
Q6070~Q6075	2215896,	KTC3200-BL,	F6902A,F6902B	25052133	 NSCT-1P2031
	2215895,	KTC3200-GR,		Fuse label	
	2210755,	2SC1775A-E,	F6901C	29362801	T10AL250V <O>
	2210756,	2SC1775A-F,		Relays	
	2211732 or	2SC1845-F or	RL6901	25065561,	NRL-1P5A-DC12-127,
	2211733	2SC1845-E	RL6902	25065508,	NRL-1P10A-DC12-093,
Q6303	2215995	KTA1267-GR,		25065515 or	NRL-1P5A-DC12-096 or
	2213354	2SA933S-R or		25065526	NRL-1P5A-DC12-102
	2213355	2SA933S-S		Sockets	
Q6601~Q6603	2215864	KTC3199-GR	JL6402A	25051087	NSCT-3P874
	2212115,	2SC2458-GR,	JL6803A,JL6804A	25051110	NSCT-6P897
	2213284 or	2SC1740S-R or	JL6805A	25051108	NSCT-4P895
	2213285	2SC1740S-S	JL6951A	25051109	NSCT-5P896
Q6701~Q6703	2215896,	KTC3200-BL,	JL6952A	25051109	NSCT-5P896
	2215895,	KTC3200-GR,	JL6953A	25051087	NSCT-3P874
	2210755,	2SC1775A-E,	P6931A	25052209	NSCT-13P2106
	2210756,	2SC1775A-F,		Plugs	
	2211732 or	2SC1845-F or	P6000A~P6005A	25056010	NPLG-5P0960
	2211733	2SC1845-E	P6011A	25056015	NPLG-10P0965
Q6901	2215864	KTC3199-GR	P6080~P6085	25055038	NPLG-2P29
	2212115,	2SC2458-GR,	P6301	25055038	NPLG-2P29
	2213284 or	2SC1740S-R or	P931	25055701	NPLG-5P657
	2213285	2SC1740S-S		Heat sink	
	Diodes		D6903A	27160499	RAD-164
D6000~D6005	223163,	1SS133,		Bar	
D6306,D6307	223205 or	1SS270A or	C6901A	27141817	BUS
D6701,D6702	223222	WG713A		Screws	
D6703,D6704	224470512	MTZJ5.1B	D6903B,D6904B	82143010	3P+10FN(BC),Pan head
D6904,D6905	22380274,	RS603M,		Clamps	
	22380038 or	RBV602 or	P6840~P6842	260226	CP-2S
	22380130	D5SBA20			
D6906	223163,	1SS133,			
	223205 or	1SS270A or			
	223222	WG713A			

CAUTION: Replacement for transistor of mark *, if necessary must be made from the same beta group (HFE) as the original type.

NOTE: THE COMPONENTS IDENTIFIED BY MARK  ARE CRITICAL FOR RISK OF FIRE AND ELECTRIC SHOCK. REPLACE ONLY WITH PART NUMBER SPECIFIED.

NOTE:

<D>: 120V model only
<P>: European model only
<O>: Except 120V model

PRINTED CIRCUIT BOARD-PARTS LIST 5

SPEAKER TERMINAL PC BOARD (NAETC-7475-1A/1B)

CIRCUIT NO.	PART NO.	DESCRIPTION
	Diodes	
D6600,D6601	223163,	1SS133,
D6604	223205 or 223222	1SS270A or WG713A
	Coils	
L6800~L6805	231176S	S-1.3C
	Capacitors	
C6600	374721034	0.01uF+/-5%,50V,Plastic
C6840~C6847	374721034	0.01uF+/-5%,50V,Plastic <O>
	Relays	
RL6600,RL6601	25065563,	NRL-2P5A-DC24-129,
RL6603,RL6604	25065517 or 25065586	NRL-2P5A-DC24-098 or NRL-2P5A-DC24-142
	Terminals	
P6800	25060330 25060331	NTM-4PDMN261 <D> NTM-4PDMN262 <O>
P6801	25060332	NTM-4PDMN263
P6802	25060326 25060327	NTM-8PDMN257 <D> NTM-8PDMN258 <O>
	Sockets	
JL6803B	25050283	NSCT-6P111
JL6804B	25050283	NSCT-6P111
JL6805B	25050281	NSCT-4P109

SECONDARY CIRCUIT PC BOARD (NAPS-7477-1A/1B)

CIRCUIT NO.	PART NO.	DESCRIPTION
	Capacitor	
C9591	374721044	0.1uF+/-5%,50V,Plastic
	Resistors	
R9591,R9592	453530104	1ohm+/-5%,1/2W,Metal
R9594	453530394 453530124	3.9ohm+/-5%,1/2W,Metal <D> 1.2ohm+/-5%,1/2W,Metal <O>
	Fuse holders	
F9501A,F9501B	25052133T	 NSCT-1P2031
	Fuse label	
F9501C	29361747	T2.5AL250V <O>
	Sockets	
JL6951B	25051109	NSCT-5P896
JL6952B	25051109	NSCT-5P896
JL6953B	25051087	NSCT-3P874
JL9501A	25051109	NSCT-5P896
P7502B	25052052 or 25051850	NSCT-6P1839 or NSCT-6P1637

THERMAL DETECTOR PC BOARD (NAETC-7480-1A/1B)

CIRCUIT NO.	PART NO.	DESCRIPTION
	Thermistor	
R6380	4000153	PTH9M04BF222TS2F333
	Socket	
JL6402B	25051087	NSCT-3P874

DRIVER CIRCUIT PC BOARD (NAAF-7483-1A/1B/1C/1D/1E/1F)

CIRCUIT NO.	PART NO.	DESCRIPTION
	Transistors	
Q5000~Q5002	2211733,	* 2SC1845-E,
Q5010~Q5012	2210755 or 2210756,	* 2SC1775A-E or * 2SC1775A-F,
Q5003~Q5005	2215896,	* KTC3200-BL,
Q5013~Q5015	2210755, 2210756 or 2211733	* 2SC1775A-E, * 2SC1775A-F or * 2SC1845-E
Q5020~Q5022	2211793 or 2211792	2SA992-E or 2SA992-F
Q5030~Q5032	2211354 or 2211353	2SA949-Y or 2SA949-O
Q5033~Q5035	2215844, 2211353, 2211354 or 2215843	KTA1024-Y, 2SA949-O, 2SA949-Y or KTA1024-O
Q5040~Q5042	2211634 or 2211633	2SC2229-Y or 2SC2229-O
Q5043~Q5045	2215854, 2211633, 2211634 or 2215853	KTC3206-Y, 2SC2229-O, 2SC2229-Y or KTC3206-O
Q5050~Q5052	2212115, 2213284 or 2213285	2SC2458-GR, 2SC1740S-R or 2SC1740S-S
Q5053~Q5055	2215864, 2212115, 2213284 or 2213285	KTC3199-GR, 2SC2458-GR, 2SC1740S-R or 2SC1740S-S
	Diodes	
D5000~D5005	224470562	MTZJ5.6B
	Capacitors	
C5000~C5005	374721015	100pF+/-10%,50V,Plastic
C5010~C5015	393341017	100uF,16V,Elect.
C5020~C5025	394681007	10uF,50V,Elect.
C5040~C5045	393342217	220uF,16V,Elect.
C5050~C5055	394684707	47uF,50V,Elect.
C5100~C5105	394671007	10uF,63V,Elect.
C5110~C5115	394671007	10uF,63V,Elect.
	Resistors	
R5120~R5122	415474714	470ohm+/-5%,1/4W,NF carbon
R5160~R5165	415471214	120ohm+/-5%,1/4W,NF carbon
R5170~R5175	415471214	120ohm+/-5%,1/4W,NF carbon
R5180~R5185	415471004	10ohm+/-5%,1/4W,NF carbon
R5190~R5195	415471004	10ohm+/-5%,1/4W,NF carbon
	Sockets	
P6000B~P6005B	25052288	NSCT-5P2185
P6011B	25052293	NSCT-10P2190
	Plug	
P404A	25055156	NPLG-12P140
	Holders	
P5000,P5002	27190540-1	Clamp
P5003	27190540-1	Clamp

CAUTION: Replacement for transistor of mark *, if necessary must be made from the same beta group (HFE) as the original type.

NOTE: THE COMPONENTS IDENTIFIED BY MARK  ARE CRITICAL FOR RISK OF FIRE AND ELECTRIC SHOCK. REPLACE ONLY WITH PART NUMBER SPECIFIED.

<D>: 120V model only
<O>: Except 120V model

PRINTED CIRCUIT BOARD-PARTS LIST 6

PRIMARY CIRCUIT PC BOARD (NAPS-7484-1A/1B/1C/1D/1E/1F)

CIRCUIT NO.	PART NO.	DESCRIPTION
	Transistor	
Q921	2215864, 2212115, 2213284 or 2213285	KTC3199-GR, 2SC2458-GR, 2SC1740S-R or 2SC1740S-S
	Diodes	
D921~D924	22380260 or 22380035	RL1N4003 or GP104003E
D925	223163, 223205 or	1SS133, 1SS270A or
	Power transformer	
T902	2301381	⚠ NPT-1358D <D>
	2301382	⚠ NPT-1358P <P/Q>
	2301383	⚠ NPT-1358DG <T/R/Q/K>
	Capacitors	
C901	3500196S	⚠ RE275V-103M,IS
C922	394662217	220uF,35V,Elect.
C923	374722234	0.022uF+/-5%,50V,Plastic
	Resistors	
R901	4000206S	⚠ RD1/2SPH-3.3M,Solid <D>
R924	443528204	82ohm+/-5%,1/2W,Metal oxide
	AC outlet	
P902	25051126	⚠ NSCT-4P913 <D>
P902	25051125	⚠ NSCT-4P912 <P/T/Q>
P902	25052115	⚠ NSCT-2P2013 <A>
P902	25052381	⚠ NSCT-2P2278 <R>
	Relay	
RL901	25065561,	⚠ NRL-1P5A-DC12-127,
	25065508,	⚠ NRL-1P10A-DC12-093,
	25065515 or	⚠ NRL-1P5A-DC12-096 or
	25065526	⚠ NRL-1P5A-DC12-102
	Fuse holders	
F901A,F901B	25052133	⚠ NSCT-1P2031<D/R/T/Q>
F902A,F902B	25052133	⚠ NSCT-1P2031<O>
F903A,F903B	25052133	⚠ NSCT-1P2031 <O>
	Switch	
S902	25065437	⚠ NSS-22157P <T/Q/R>
	Socket	
P931A	25051230	NSCT-5P1020
	Plug	
P901A	25055675 or	⚠ NPLG-2P631 or
	25056028	⚠ NPLG-2P0978

CAUTION: Replacement for transistor of mark *, if necessary must be made from the same beta group (HFE) as the original type.

NOTE: THE COMPONENTS IDENTIFIED BY MARK ⚠ ARE CRITICAL FOR RISK OF FIRE AND ELECTRIC SHOCK. REPLACE ONLY WITH PART NUMBER SPECIFIED.

<D>: 120V model only
<P>: European model only
<T>: Worldwide model only
<K>: Korean model only
<A>: Australian model only
<R>: Chinese model only
<Q>: Hongkong model only
<O>: Except 120V model

CONNECTOR PC BOARD (NAETC-7486-1A/1B/1C/1D/1E/1F)

CIRCUIT NO.	PART NO.	DESCRIPTION
	Transistors	
Q2225	2213290	DTC114ES
Q2231,Q2232	2215770 or	KRA102M or
Q2234,Q2236	2213510	DTA114ES
Q2237	2215770 or 2213510	KRA102M or DTA114ES
	Sockets	
P105A	25051237	NSCT-12P1027
P106A	25051526	NSCT-4P1313
P107A	25051240	NSCT-15P1030
P205A	25055709	NPLG-13P665
P207A	25055708	NPLG-12P664

POWER SWITCH PC BOARD (NASW-7487-1B/1C/1D/1E/1F)

CIRCUIT NO.	PART NO.	DESCRIPTION
	Capacitors	
C902	3300030	⚠ DE1307E472M-KH,IS,IS <O>
	Switch	
S906	25035702	⚠ NPS-121-L665P <O>

MAIN MICROPROCESSOR

Connection diagram

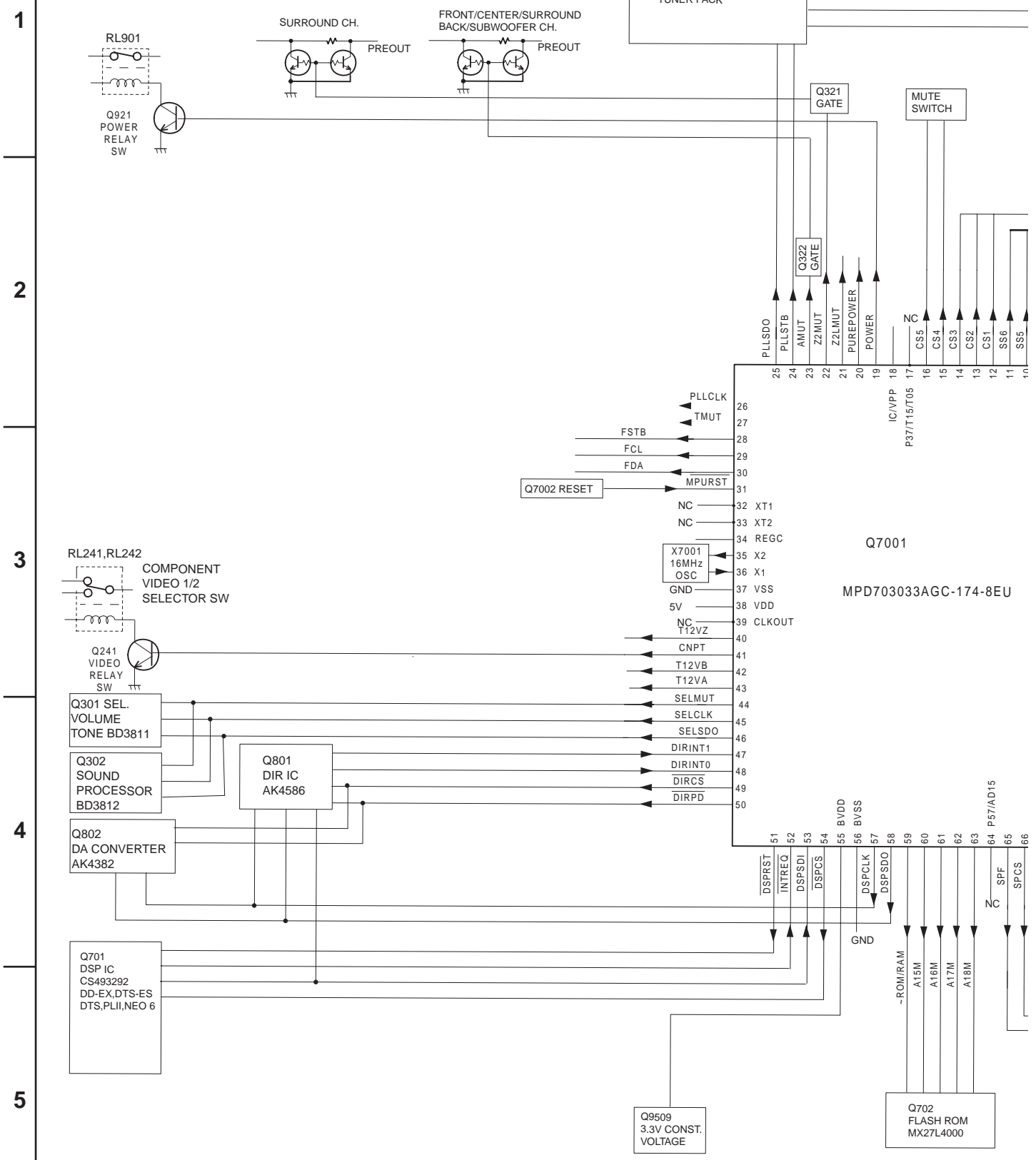

MAIN MICROPROCESSOR

Connection diagram

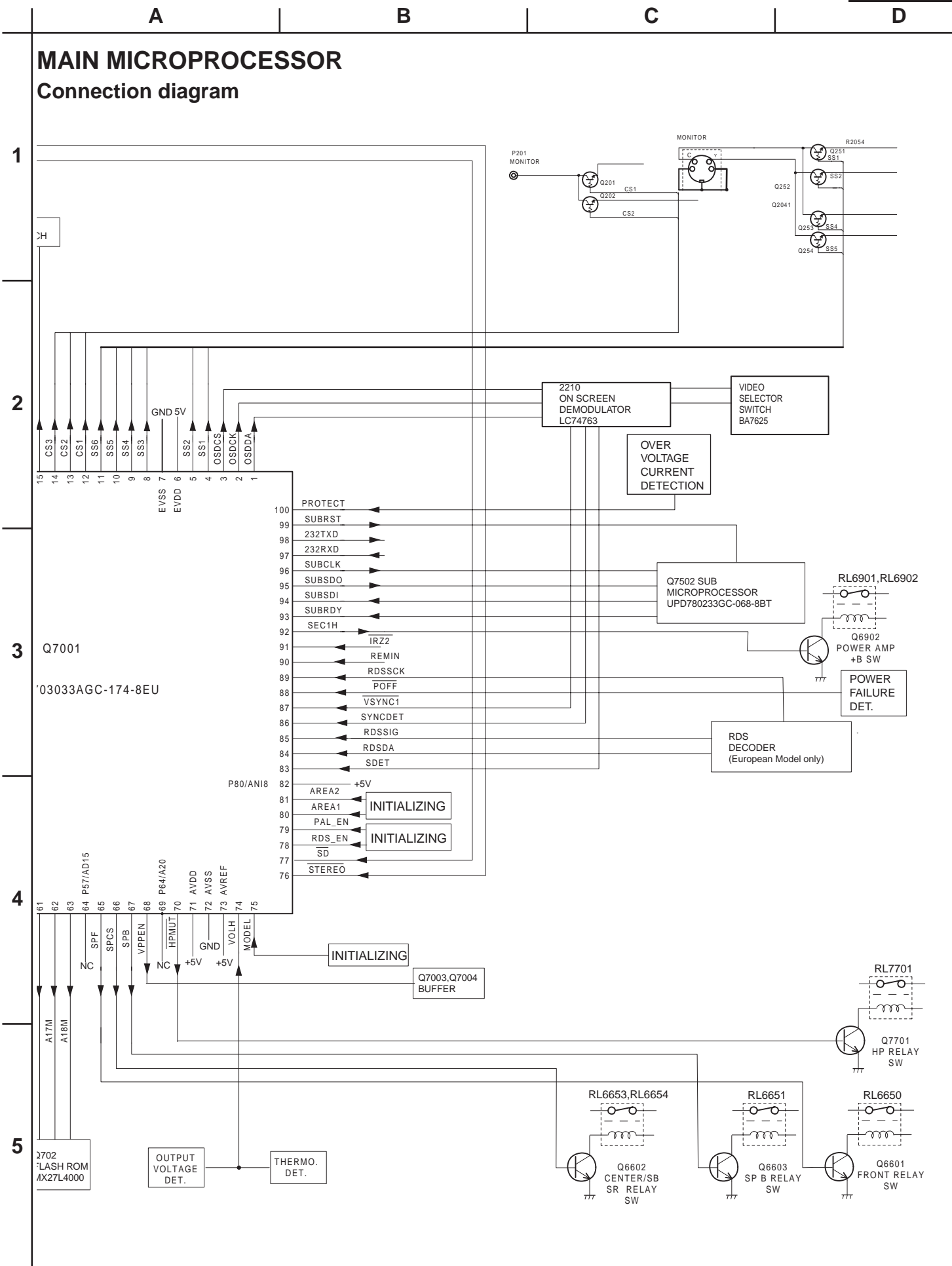

MAIN MICROPROCESSOR-TERMINAL DESCRIPTIONS

No.	Function	I/O	Act	Description	No.	Function	I/O	Act	Description
1	OSDDA	O	H	Serial data signal output pin to OSD IC.	60	A15	O	H	Address 15 output pin to Boot ROM.
2	OSDCL	O	CLK	Serial clock signal output pin to OSD IC.	61	A16	O	H	Address 16 output pin to Boot ROM.
3	OSDCS	O	H	Chip select signal output pin to OSD IC.	62	A17	O	H	Address 17 output pin to Boot ROM.
4	SVS1	O	H	Logic output pin of S video 1.	63	A18	O	H	Address 18 output pin to Boot ROM.
5	SVS2	O	H	Logic output pin of S video 2.	65	SPF	O	H	Speaker relay control signal output pin for the front channel.
6	VCC			Power supply pin. Connect to 5V.	66	SPCS	O	H	Speaker relay control signal output pin for the center and surround channels.
7	VSS			Power supply pin. Connect to the ground.	67	SPB	O	H	Speaker relay control signal output pin for the speaker B.
8	SVS3	O	H	Logic output pin of S video 3..	68	VPPEN	O	H	Vpp voltage generation circuit to rewrite the program.
9	SVS4	O	H	Logic output pin of S video 4.	70	HPMUT	O	H	Muting control signal output pin for headphone.
10	SVS5	O	H	Logic output pin of S video 5.	71	VCC			Power supply pin. Connect to 5V.
11	SVS6	O	H	Logic output pin of S video 6.	72	VSS			Power supply pin. Connect to the ground.
12	VCS1	O	H	Logic output pin of video 1.	73	VCC			Power supply pin. Connect to 5V.
13	VCS2	O	H	Logic output pin of video 2.	74	VOLH	I	ANA	Output level detection input pin.
14	VCS3	O	H	Logic output pin of video 3.	75	MODEL	I	ANA	Initializing input pin of model.
15	VCS4	I/O	H	Logic output pin of video 4.	76	STEREO	I	H	Stereo broadcast detection input pin.
16	VCS5	O	H	Logic output pin of video 5.	77	~SD	I	L	Broadcast detection input pin more than the muting level.
17	VCS6	O	H	Logic output pin of video 6.	78	RDSEN	I	H	Initializing input pin of RDS broadcast.
19	POWER	O	H	Output pin to control the power supply of amplifier section.	79	PALEN	I	L/H	Initializing input pin of PAL or NTSC.
20	PUREPOWER	O	H	Not used.	80	AREA1	I	H	Initializing input pin of band aria.
21	Z2LMUT	O	H	Not used.	81	AREA2	I	H	Initializing input pin of band aria.
22	Z2MUT	O	H	Muting control output pin for Zone 2.	83	SDET	I	H	S video signal detection input pin
23	AMUT	O	H	Audio muting control output pin.	84	RSDSA	I	H	Data input pin from RDS decoder.
24	PLLSTB	O	H	Strobe signal output pin to PLL IC in the tuner pack.	85	RDSSIG	I	H	Signal input pin from RDS decoder
25	PLLSDO	O	H	Data signal output pin to PLL IC.	86	SYNC	I	H	External synchronizing judgement input pin from OSD IC.
26	PLLCLK	O	H	Clock signal output pin to PLL IC.	87	~VSYNC	I	L	Vertical synchronizing signal input pin.
27	TMUT	O	H	Muting control output pin for tuner section.	88	~POFF	I	L	Power failure detection input pin.
28	FSTB	O	H	Not used.	89	RDSSCK	I	CLK	Clock signal input pin from RDS decoder.
29	FCL	O	H	Not used.	90	~IRIN	I	L	Not used.
30	FDA	O	H	Not used.	91	~IRZ2	I	L	Not used.
31	~RESET			System reset pin	92	SEC1H	O	H	Amplifier gain control output pin.
35	XOUT			Oscillator circuit output pin for main clock. Connector the 16MHz ceramic resonator.	93	SUBRDY	I	H	Ready signal input pin from the sub microprocessor.
36	XIN			Oscillator circuit input pin for main clock. Connector the 16MHz ceramic resonator.	94	SUBSDI/SI	I	H	Data signal input pin from the sub microprocessor.
37	VSS			Power supply pin. Connect to the ground.	95	SUBSDO/SO	O	H	data signal output pin to the sub microprocessor.
38	VCC			Power supply pin. Connect to 5V.	96	SUBCLK/SCL	O	CLK	Clock signal output pin to the sub microprocessor.
41	CNPT	O	H	Composite signal selector pin.	97	232RXD	I	H	Not used.
42	T12VB	O	H	Not used.	98	232TXD	O	H	Not used.
43	T12VA	O	H	Not used.	99	SUBRST/HS	O	H	Reset signal output pin to the sub microprocessor.
44	SELMUT	O	H	Muting control signal output pin to BD3811.	100	PROTECT	I	H	over current and over voltage detection input pin.
45	SELCLK	O	H	Clock signal output pin to BD3811.					
46	SELSDO	O	H	Data signal output pin to BD3811.					
47	DIRINT1	I	H	Interrupter signal input pin from DIR IC.					
48	DIRINT0	I	H	Interrupter signal input pin from DIR IC.					
49	~DIRCS	O	L	Chip select signal output pin to DIR IC.					
50	~DIRPD	O	L	Power down signal output pin to DIR IC.					
51	~DSPRST	O	H	Reset signal output pinto DIR IC.					
52	~INTREQ	I	L	Interrupter signal of DSP IC and rollback signal input/output pin.					
53	DSPSDI	I	H	Serial data signal input pin from DIR and DSP ICs.					
54	~DSPCS	O	L	Chip select signal output pin to DSP IC.					
55	BVDD			Power supply pin. Connect to 3.3V.					
56	BVSS			Power supply pin. Connect to ground.					
57	DSPCLK	O	H	Serial clock signal output pin to DIR and DSP ICs.					
58	DSPSDO	O	H	Serial data signal output pin to DIR and DSP ICs.					
59	~ROM/RAM	O	L/H	ROM/RAM select pin to DSP IC.					

MAIN MICROPROCESSOR

Connection diagram

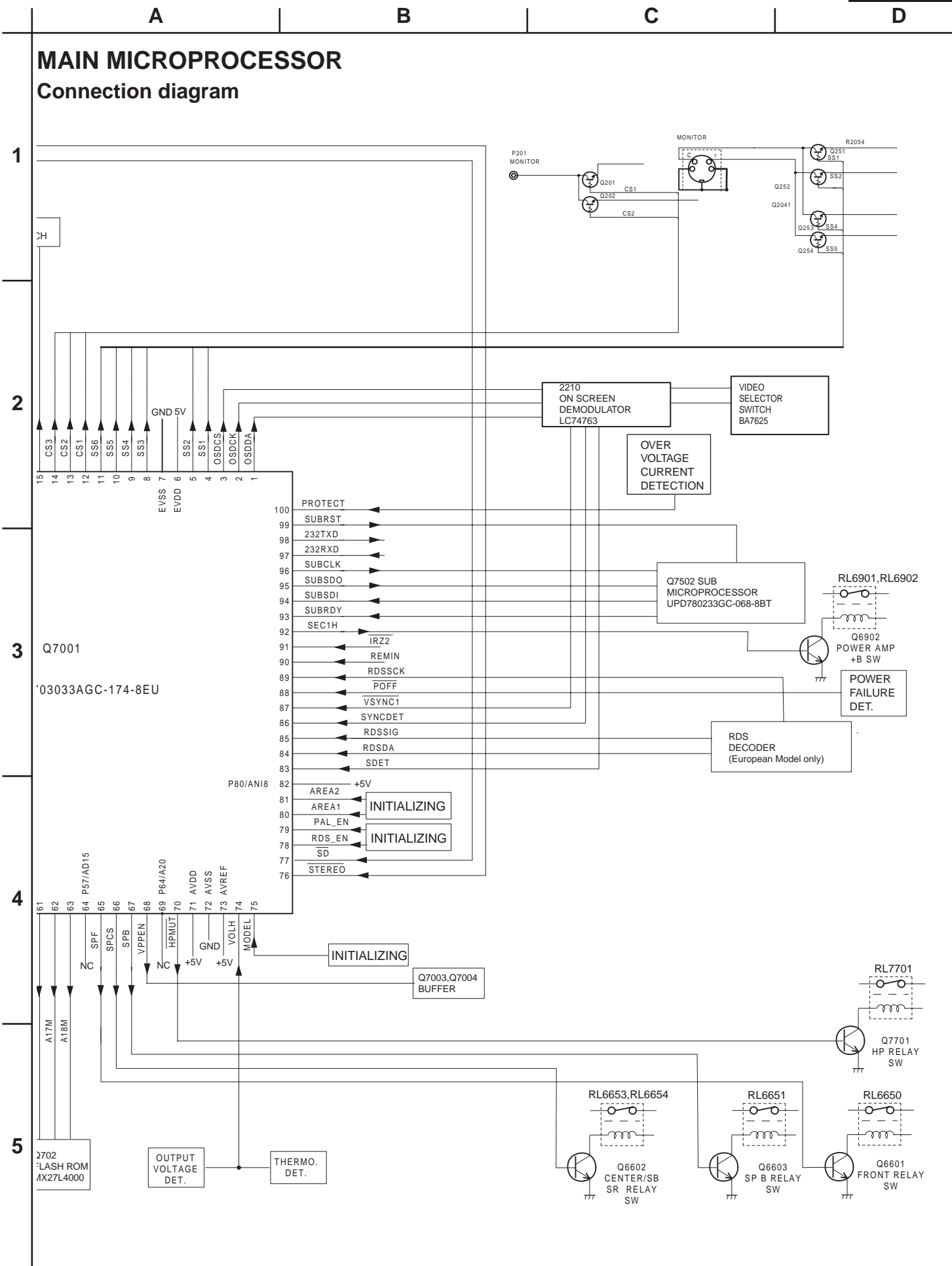

SUB-MICROPROCESSOR
Connection diagram

1

2

3

4

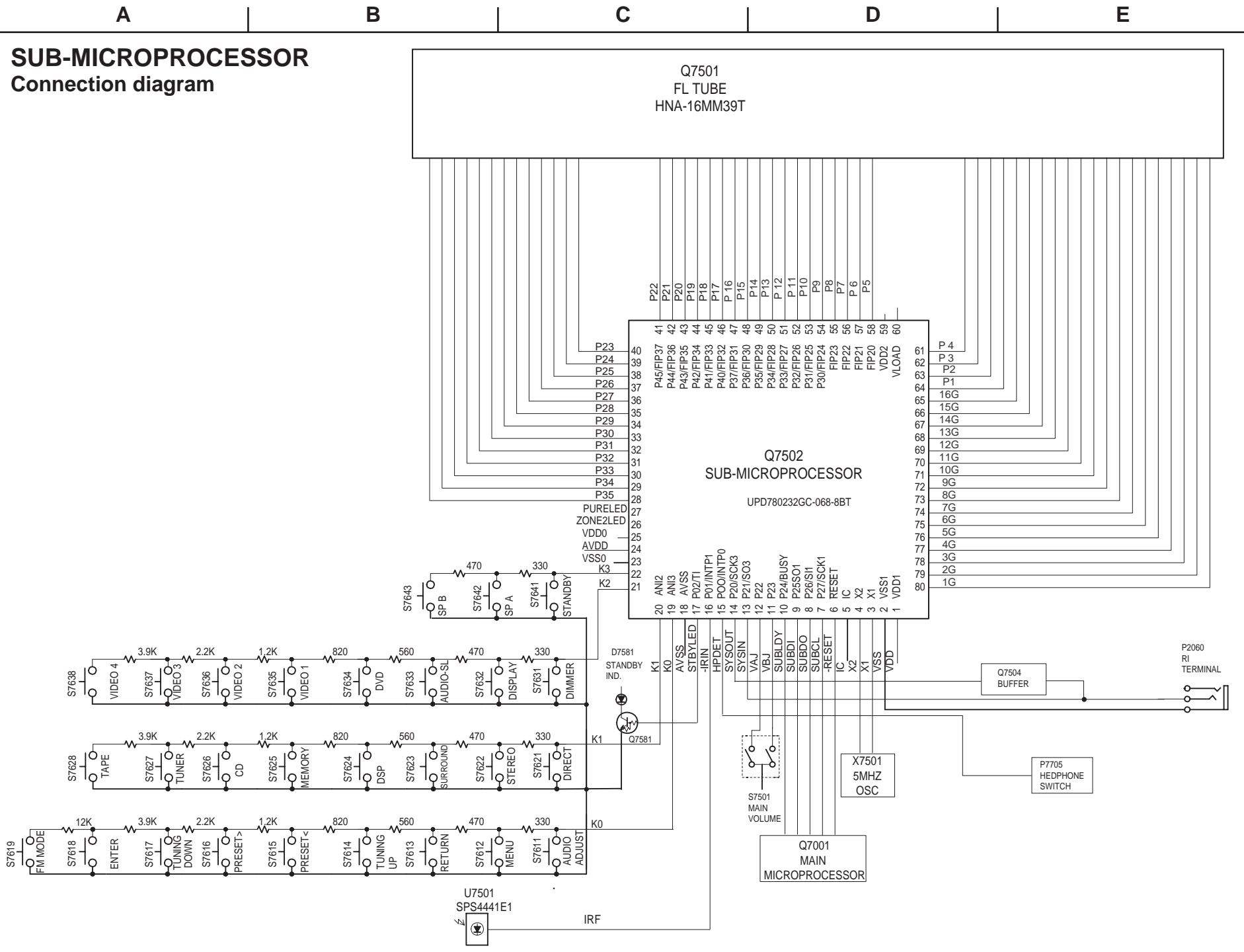

MAIN MICROPROCESSOR-TERMINAL DESCRIPTIONS

No.	Function	I/O	Act	Description	No.	Function	I/O	Act	Description
1	OSDDA	O	H	Serial data signal output pin to OSD IC.	60	A15	O	H	Address 15 output pin to Boot ROM.
2	OSDCL	O	CLK	Serial clock signal output pin to OSD IC.	61	A16	O	H	Address 16 output pin to Boot ROM.
3	OSDCS	O	H	Chip select signal output pin to OSD IC.	62	A17	O	H	Address 17 output pin to Boot ROM.
4	SVS1	O	H	Logic output pin of S video 1.	63	A18	O	H	Address 18 output pin to Boot ROM.
5	SVS2	O	H	Logic output pin of S video 2.	65	SPF	O	H	Speaker relay control signal output pin for the front channel.
6	VCC			Power supply pin. Connect to 5V.	66	SPCS	O	H	Speaker relay control signal output pin for the center and surround channels.
7	VSS			Power supply pin. Connect to the ground.	67	SPB	O	H	Speaker relay control signal output pin for the speaker B.
8	SVS3	O	H	Logic output pin of S video 3..	68	VPPEN	O	H	Vpp voltage generation circuit to rewrite the program.
9	SVS4	O	H	Logic output pin of S video 4.	70	HPMUT	O	H	Muting control signal output pin for headphone.
10	SVS5	O	H	Logic output pin of S video 5.	71	VCC			Power supply pin. Connect to 5V.
11	SVS6	O	H	Logic output pin of S video 6.	72	VSS			Power supply pin. Connect to the ground.
12	VCS1	O	H	Logic output pin of video 1.	73	VCC			Power supply pin. Connect to 5V.
13	VCS2	O	H	Logic output pin of video 2.	74	VOLH	I	ANA	Output level detection input pin.
14	VCS3	O	H	Logic output pin of video 3.	75	MODEL	I	ANA	Initializing input pin of model.
15	VCS4	I/O	H	Logic output pin of video 4.	76	STEREO	I	H	Stereo broadcast detection input pin.
16	VCS5	O	H	Logic output pin of video 5.	77	~SD	I	L	Broadcast detection input pin more than the muting level.
17	VCS6	O	H	Logic output pin of video 6.	78	RDSEN	I	H	Initializing input pin of RDS broadcast.
19	POWER	O	H	Output pin to control the power supply of amplifier section.	79	PALEN	I	L/H	Initializing input pin of PAL or NTSC.
20	PUREPOWER	O	H	Not used.	80	AREA1	I	H	Initializing input pin of band aria.
21	Z2LMUT	O	H	Not used.	81	AREA2	I	H	Initializing input pin of band aria.
22	Z2MUT	O	H	Muting control output pin for Zone 2.	83	SDET	I	H	S video signal detection input pin
23	AMUT	O	H	Audio muting control output pin.	84	RSDSA	I	H	Data input pin from RDS decoder.
24	PLLSTB	O	H	Strobe signal output pin to PLL IC in the tuner pack.	85	RDSSIG	I	H	Signal input pin from RDS decoder
25	PLLSDO	O	H	Data signal output pin to PLL IC.	86	SYNC	I	H	External synchronizing judgement input pin from OSD IC.
26	PLLCLK	O	H	Clock signal output pin to PLL IC.	87	~VSYNC	I	L	Vertical synchronizing signal input pin.
27	TMUT	O	H	Muting control output pin for tuner section.	88	~POFF	I	L	Power failure detection input pin.
28	FSTB	O	H	Not used.	89	RDSSCK	I	CLK	Clock signal input pin from RDS decoder.
29	FCL	O	H	Not used.	90	~IRIN	I	L	Not used.
30	FDA	O	H	Not used.	91	~IRZ2	I	L	Not used.
31	~RESET			System reset pin	92	SEC1H	O	H	Amplifier gain control output pin.
35	XOUT			Oscillator circuit output pin for main clock. Connector the 16MHz ceramic resonator.	93	SUBRDY	I	H	Ready signal input pin from the sub microprocessor.
36	XIN			Oscillator circuit input pin for main clock. Connector the 16MHz ceramic resonator.	94	SUBSDI/SI	I	H	Data signal input pin from the sub microprocessor.
37	VSS			Power supply pin. Connect to the ground.	95	SUBSDO/SO	O	H	data signal output pin to the sub microprocessor.
38	VCC			Power supply pin. Connect to 5V.	96	SUBCLK/SCL	O	CLK	Clock signal output pin to the sub microprocessor.
41	CNPT	O	H	Composite signal selector pin.	97	232RXD	I	H	Not used.
42	T12VB	O	H	Not used.	98	232TXD	O	H	Not used.
43	T12VA	O	H	Not used.	99	SUBRST/HS	O	H	Reset signal output pin to the sub microprocessor.
44	SELMUT	O	H	Muting control signal output pin to BD3811.	100	PROTECT	I	H	over current and over voltage detection input pin.
45	SELCLK	O	H	Clock signal output pin to BD3811.					
46	SELSDO	O	H	Data signal output pin to BD3811.					
47	DIRINT1	I	H	Interrupter signal input pin from DIR IC.					
48	DIRINT0	I	H	Interrupter signal input pin from DIR IC.					
49	~DIRCS	O	L	Chip select signal output pin to DIR IC.					
50	~DIRPD	O	L	Power down signal output pin to DIR IC.					
51	~DSPRST	O	H	Reset signal output pinto DIR IC.					
52	~INTREQ	I	L	Interrupter signal of DSP IC and rollback signal input/output pin.					
53	DSPSDI	I	H	Serial data signal input pin from DIR and DSP ICs.					
54	~DSPCS	O	L	Chip select signal output pin to DSP IC.					
55	BVDD			Power supply pin. Connect to 3.3V.					
56	BVSS			Power supply pin. Connect to ground.					
57	DSPCLK	O	H	Serial clock signal output pin to DIR and DSP ICs.					
58	DSPSDO	O	H	Serial data signal output pin to DIR and DSP ICs.					
59	~ROM/RAM	O	L/H	ROM/RAM select pin to DSP IC.					

SUB MICROPROCESSOR-TERMINAL DESCRIPTION

Pin No.	Symbol	I/O	Description	Pin No.	Symbol	I/O	Description
1	VDD		Power supply terminal. Connect to 5V.	41	P22	O	Segment output terminal of P22.
2	VSS		Ground terminal.	42	P21	O	Segment output terminal of P21.
3	X1		Ceramic oscillator connection terminals for main system.	43	P20	O	Segment output terminal of P20.
4	X2		Connect the 5MHz ceramic oscillator between #3 and #4.	44	P19	O	Segment output terminal of P19.
5	IC/VPP		Internal connection terminal	45	P18	O	Segment output terminal of P18.
6	~RESET	I	System reset signal input terminal.	46	P17	O	Segment output terminal of P17.
7	SUBCL/SCK	I	Clock input terminal to transmit the signal from main microprocessor.	47	P16	O	Segment output terminal of P16.
8	SUBDO/SDI	I	Data input terminal to transmit the signal from main microprocessor.	48	P15	O	Segment output terminal of P15.
9	SUBDI/SDD	O	Data output terminal to transmit the signal to main microprocessor.	49	P14	O	Segment output terminal of P14.
10	SUBLDY	O	Data ready output terminal to transmit to the main microprocessor.	50	P13	O	Segment output terminal of P13.
11	VBJ	I	Pulse input terminal from the rotary encoder of volume.	51	P12	O	Segment output terminal of P12.
12	VAJ	I	Pulse input terminal from the rotary encoder of volume.	52	P11	O	Segment output terminal of P11.
13	SYSIN	I	System code input terminal.	53	P10	O	Segment output terminal of P10.
14	SYSOUT	I	System code output terminal.	54	P9	O	Segment output terminal of P9.
15	HPDET	I	Detection terminal of headphone insertion.	55	P8	O	Segment output terminal of P8.
16	~IRIN	I	Signal input terminal from the remote controller.	56	P7	O	Segment output terminal of P7.
17	STBYLED	O	Standby LED control output terminal.	57	P6	O	Segment output terminal of P6.
18	AVSS		Ground terminal for A/D converter.	58	P5	O	Segment output terminal of P5.
19	K0	I	Operation key connection terminal.	59	VDD2		Power supply terminal. Apply +5V.
20	K1	I	Operation key connection terminal.	60	VLOAD		Negative power supply terminal of FL controller.
21	K2	I	Operation key connection terminal.	61	P4	O	Segment output terminal of P4.
22	K3	I	Operation key connection terminal.	62	P3	O	Segment output terminal of P3.
23	VSS0		Ground terminal	63	P2	O	Segment output terminal of P2.
24	AVDD		Power supply terminal for A/D converter.	64	P1	O	Segment output terminal of P1.
25	VDDD		Power supply terminal. Apply +5V.	65	16G	O	Grid output terminal of 16G.
26	ZONE2LED	O	Not used.	66	15G	O	Grid output terminal of 15G.
27	PURELED	O	Not used.	67	14G	O	Grid output terminal of 14G.
28	P35	O	Segment output terminal of P35.	68	13G	O	Grid output terminal of 13G.
29	P34	O	Segment output terminal of P34.	69	12G	O	Grid output terminal of 12G.
30	P33	O	Segment output terminal of P33.	70	11G	O	Grid output terminal of 11G.
31	P32	O	Segment output terminal of P32.	71	10G	O	Grid output terminal of 10G.
32	P31	O	Segment output terminal of P31.	72	9G	O	Grid output terminal of 9G.
33	P30	O	Segment output terminal of P30.	73	8G	O	Grid output terminal of 8G.
34	P29	O	Segment output terminal of P29.	74	7G	O	Grid output terminal of 7G.
35	P28	O	Segment output terminal of P28.	75	6G	O	Grid output terminal of 6G.
36	P27	O	Segment output terminal of P27.	76	5G	O	Grid output terminal of 5G.
37	P26	O	Segment output terminal of P26.	77	4G	O	Grid output terminal of 4G.
38	P25	O	Segment output terminal of P25.	78	3G	O	Grid output terminal of 3G.
39	P24	O	Segment output terminal of P24.	79	2G	O	Grid output terminal of 2G.
40	P23	O	Segment output terminal of P23.	80	1G	O	Grid output terminal of 1G.

SUB-MICROPROCESSOR
Connection diagram

1

2

3

4

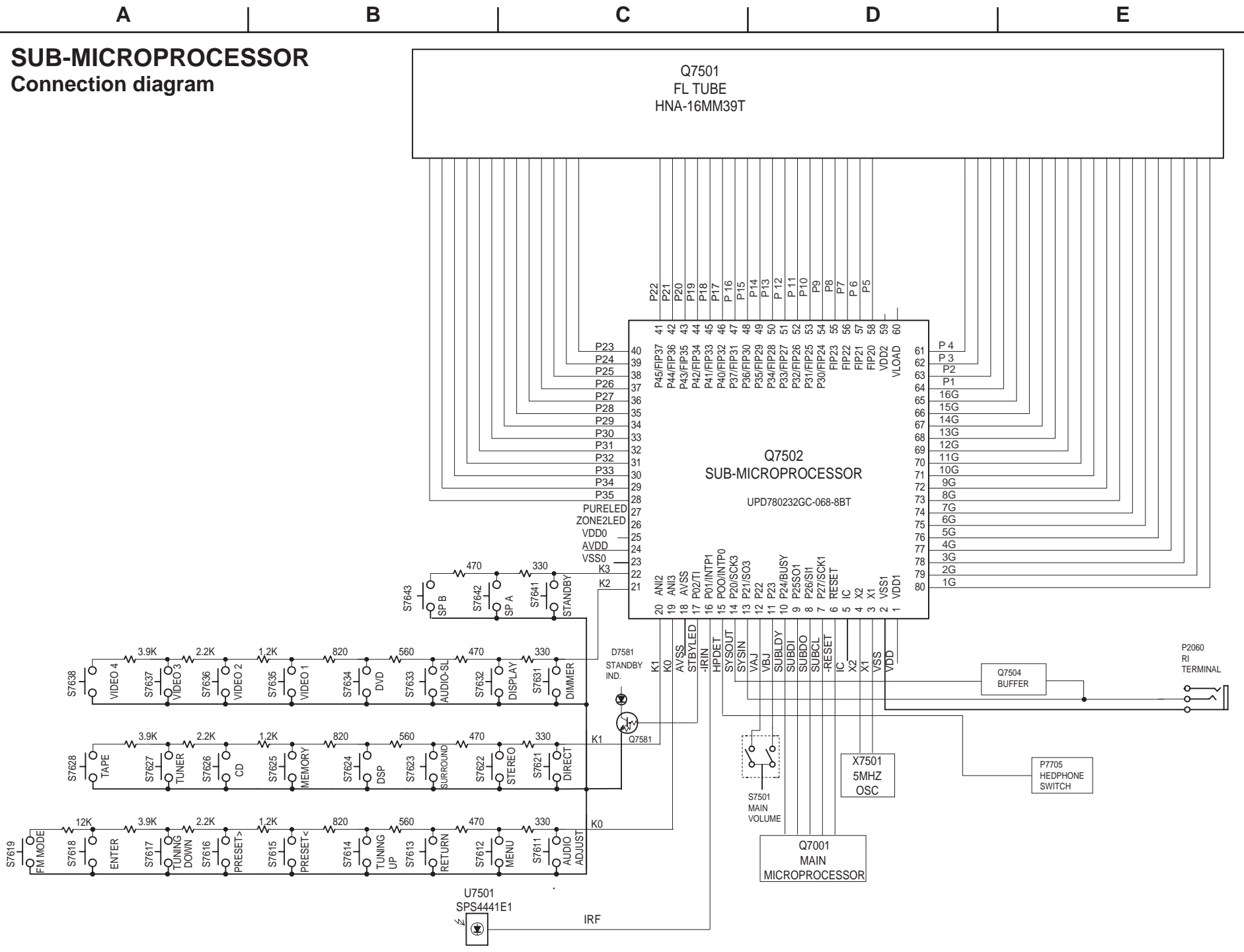

MAIN MICROPROCESSOR-TERMINAL DESCRIPTIONS

No.	Function	I/O	Act	Description	No.	Function	I/O	Act	Description
1	OSDDA	O	H	Serial data signal output pin to OSD IC.	60	A15	O	H	Address 15 output pin to Boot ROM.
2	OSDCL	O	CLK	Serial clock signal output pin to OSD IC.	61	A16	O	H	Address 16 output pin to Boot ROM.
3	OSDCS	O	H	Chip select signal output pin to OSD IC.	62	A17	O	H	Address 17 output pin to Boot ROM.
4	SVS1	O	H	Logic output pin of S video 1.	63	A18	O	H	Address 18 output pin to Boot ROM.
5	SVS2	O	H	Logic output pin of S video 2.	65	SPF	O	H	Speaker relay control signal output pin for the front channel.
6	VCC			Power supply pin. Connect to 5V.	66	SPCS	O	H	Speaker relay control signal output pin for the center and surround channels.
7	VSS			Power supply pin. Connect to the ground.	67	SPB	O	H	Speaker relay control signal output pin for the speaker B.
8	SVS3	O	H	Logic output pin of S video 3..	68	VPPEN	O	H	Vpp voltage generation circuit to rewrite the program.
9	SVS4	O	H	Logic output pin of S video 4.	70	HPMUT	O	H	Muting control signal output pin for headphone.
10	SVS5	O	H	Logic output pin of S video 5.	71	VCC			Power supply pin. Connect to 5V.
11	SVS6	O	H	Logic output pin of S video 6.	72	VSS			Power supply pin. Connect to the ground.
12	VCS1	O	H	Logic output pin of video 1.	73	VCC			Power supply pin. Connect to 5V.
13	VCS2	O	H	Logic output pin of video 2.	74	VOLH	I	ANA	Output level detection input pin.
14	VCS3	O	H	Logic output pin of video 3.	75	MODEL	I	ANA	Initializing input pin of model.
15	VCS4	I/O	H	Logic output pin of video 4.	76	STEREO	I	H	Stereo broadcast detection input pin.
16	VCS5	O	H	Logic output pin of video 5.	77	~SD	I	L	Broadcast detection input pin more than the muting level.
17	VCS6	O	H	Logic output pin of video 6.	78	RDSEN	I	H	Initializing input pin of RDS broadcast.
19	POWER	O	H	Output pin to control the power supply of amplifier section.	79	PALEN	I	L/H	Initializing input pin of PAL or NTSC.
20	PUREPOWER	O	H	Not used.	80	AREA1	I	H	Initializing input pin of band aria.
21	Z2LMUT	O	H	Not used.	81	AREA2	I	H	Initializing input pin of band aria.
22	Z2MUT	O	H	Muting control output pin for Zone 2.	83	SDET	I	H	S video signal detection input pin
23	AMUT	O	H	Audio muting control output pin.	84	RSDSA	I	H	Data input pin from RDS decoder.
24	PLLSTB	O	H	Strobe signal output pin to PLL IC in the tuner pack.	85	RDSSIG	I	H	Signal input pin from RDS decoder
25	PLLSDO	O	H	Data signal output pin to PLL IC.	86	SYNC	I	H	External synchronizing judgement input pin from OSD IC.
26	PLLCLK	O	H	Clock signal output pin to PLL IC.	87	~VSYNC	I	L	Vertical synchronizing signal input pin.
27	TMUT	O	H	Muting control output pin for tuner section.	88	~POFF	I	L	Power failure detection input pin.
28	FSTB	O	H	Not used.	89	RDSSCK	I	CLK	Clock signal input pin from RDS decoder.
29	FCL	O	H	Not used.	90	~IRIN	I	L	Not used.
30	FDA	O	H	Not used.	91	~IRZ2	I	L	Not used.
31	~RESET			System reset pin	92	SEC1H	O	H	Amplifier gain control output pin.
35	XOUT			Oscillator circuit output pin for main clock. Connector the 16MHz ceramic resonator.	93	SUBRDY	I	H	Ready signal input pin from the sub microprocessor.
36	XIN			Oscillator circuit input pin for main clock. Connector the 16MHz ceramic resonator.	94	SUBSDI/SI	I	H	Data signal input pin from the sub microprocessor.
37	VSS			Power supply pin. Connect to the ground.	95	SUBSDO/SO	O	H	data signal output pin to the sub microprocessor.
38	VCC			Power supply pin. Connect to 5V.	96	SUBCLK/SCL	O	CLK	Clock signal output pin to the sub microprocessor.
41	CNPT	O	H	Composite signal selector pin.	97	232RXD	I	H	Not used.
42	T12VB	O	H	Not used.	98	232TXD	O	H	Not used.
43	T12VA	O	H	Not used.	99	SUBRST/HS	O	H	Reset signal output pin to the sub microprocessor.
44	SELMUT	O	H	Muting control signal output pin to BD3811.	100	PROTECT	I	H	over current and over voltage detection input pin.
45	SELCLK	O	H	Clock signal output pin to BD3811.					
46	SELSDO	O	H	Data signal output pin to BD3811.					
47	DIRINT1	I	H	Interrupter signal input pin from DIR IC.					
48	DIRINT0	I	H	Interrupter signal input pin from DIR IC.					
49	~DIRCS	O	L	Chip select signal output pin to DIR IC.					
50	~DIRPD	O	L	Power down signal output pin to DIR IC.					
51	~DSPRST	O	H	Reset signal output pinto DIR IC.					
52	~INTREQ	I	L	Interrupter signal of DSP IC and rollback signal input/output pin.					
53	DSPSDI	I	H	Serial data signal input pin from DIR and DSP ICs.					
54	~DSPCS	O	L	Chip select signal output pin to DSP IC.					
55	BVDD			Power supply pin. Connect to 3.3V.					
56	BVSS			Power supply pin. Connect to ground.					
57	DSPCLK	O	H	Serial clock signal output pin to DIR and DSP ICs.					
58	DSPSDO	O	H	Serial data signal output pin to DIR and DSP ICs.					
59	~ROM/RAM	O	L/H	ROM/RAM select pin to DSP IC.					

A

B

C

D

PRINTED CIRCUIT BOARD VIEW 7
Power supply and output sections

1

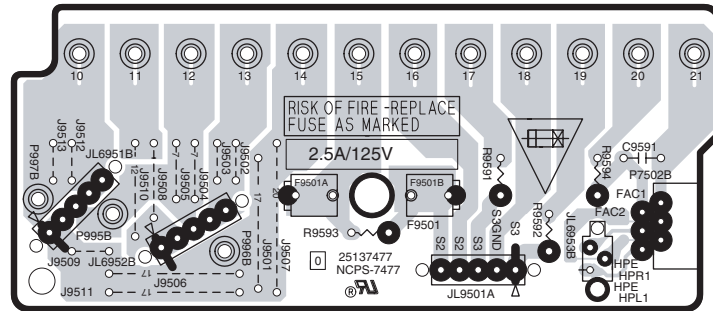

2

U17 Secondary circuit PC board

3

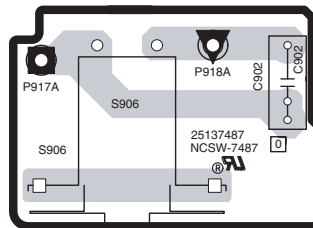

U27 Power switch PC board
 (Except 120V model)

4

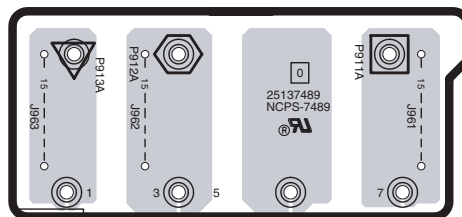

U29 Terminal PC board

5

A

B

C

D

PRINTED CIRCUIT BOARD VIEW 6
Power supply and output sections

1

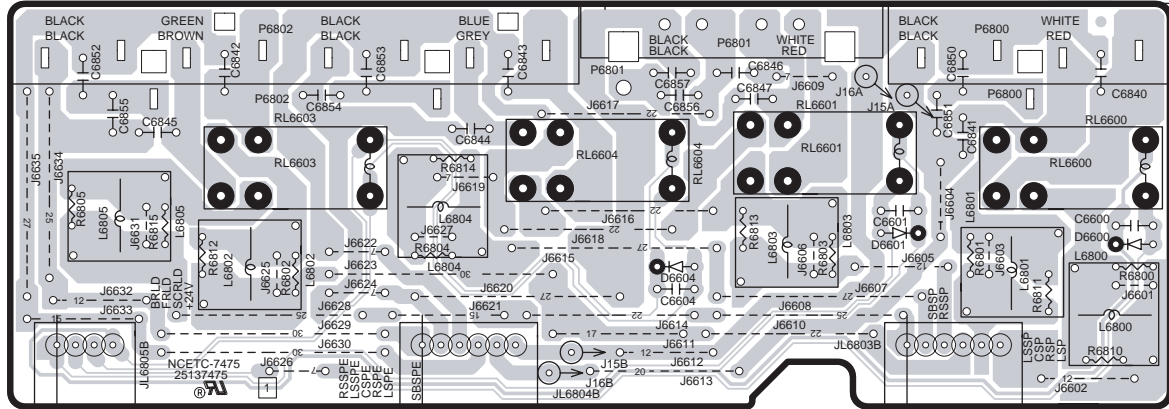

2

U16 Speaker terminal PC board

3

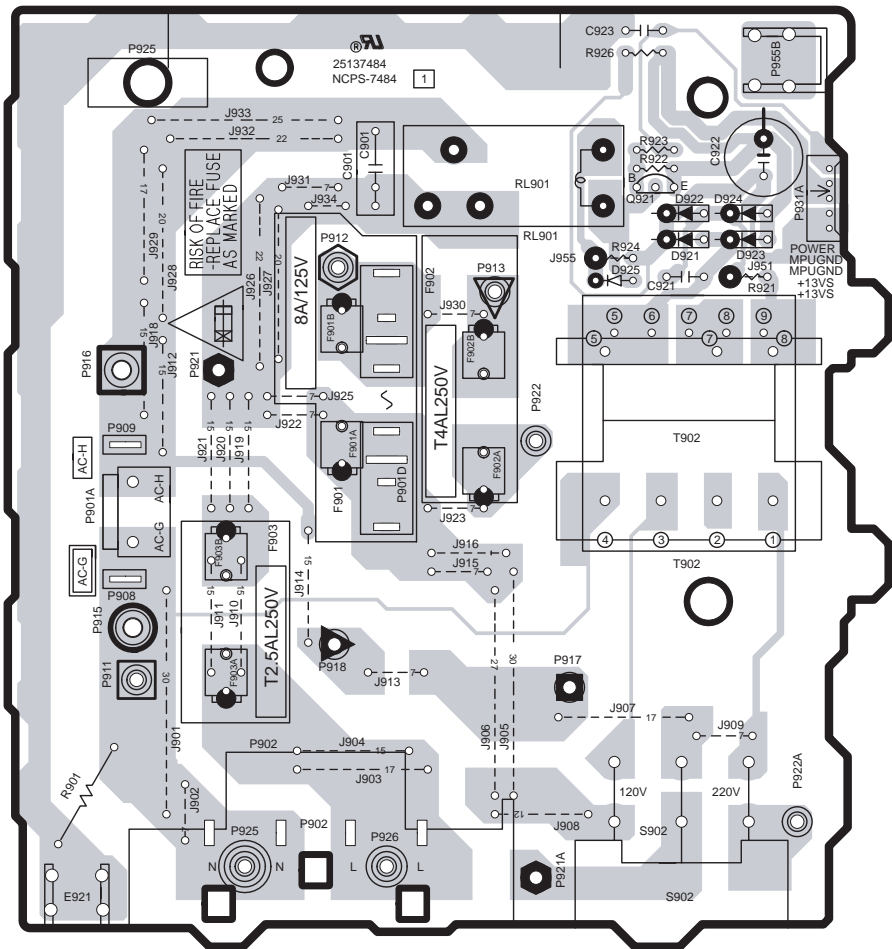

4

U24 Primary circuit PC board

5

A

B

C

D

PRINTED CIRCUIT BOARD VIEW 5-2

Power amplifier section 3

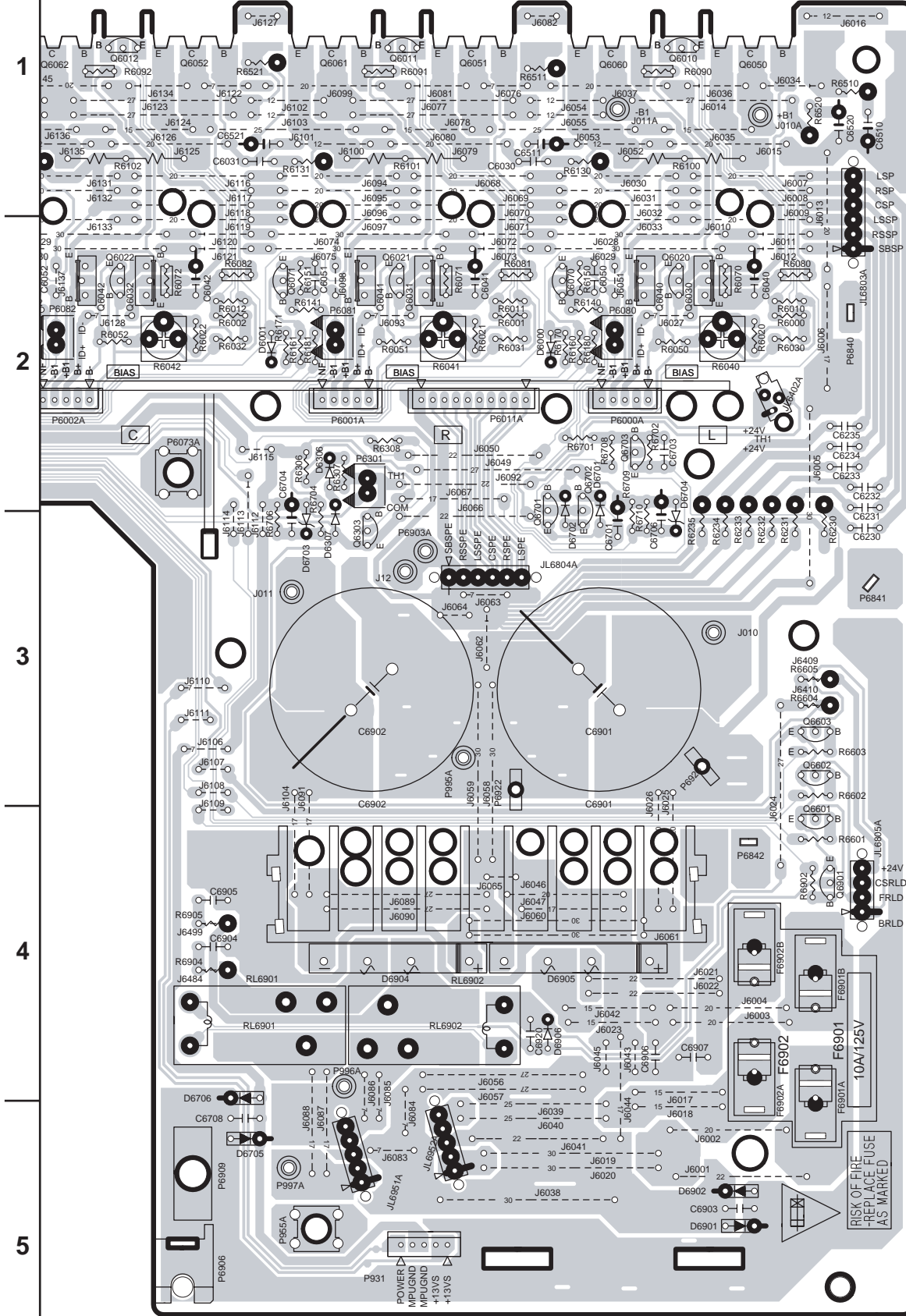

U15 Power amplifier PC board

A

B

C

D

PRINTED CIRCUIT BOARD VIEW 5-1

Power amplifier section 2

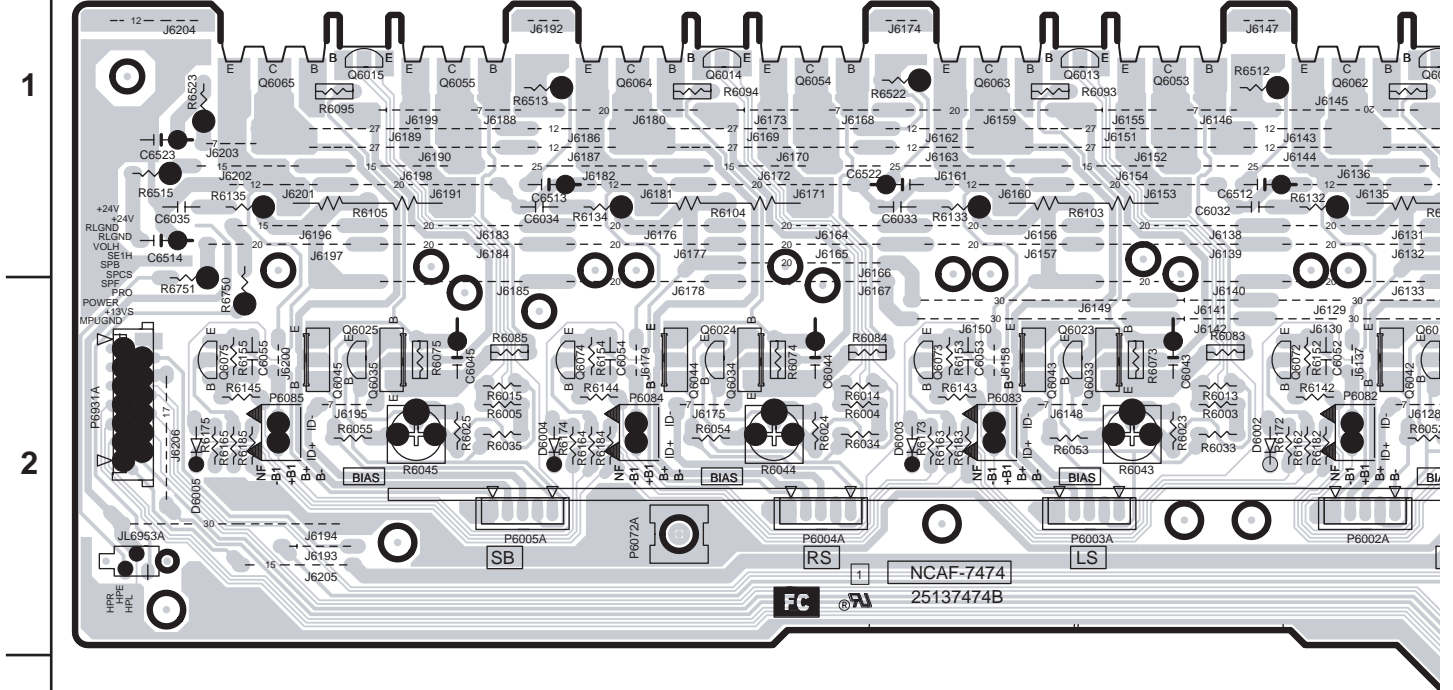

U15 Power amplifier PC board

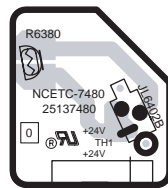

U20 Thermal detector PC board

A

B

C

D

PRINTED CIRCUIT BOARD VIEW 3

Front panel section

1

U8

U4

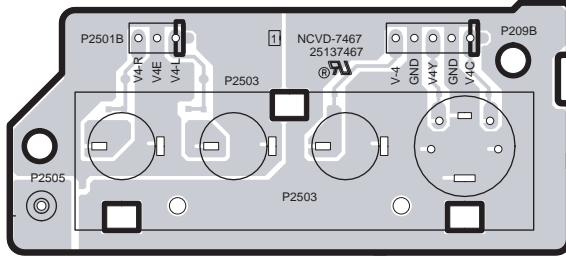

Component side

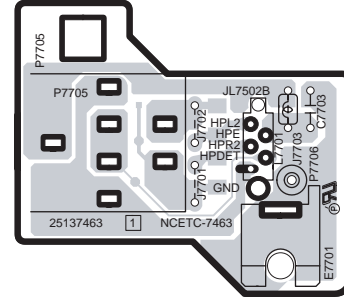

Component side

2

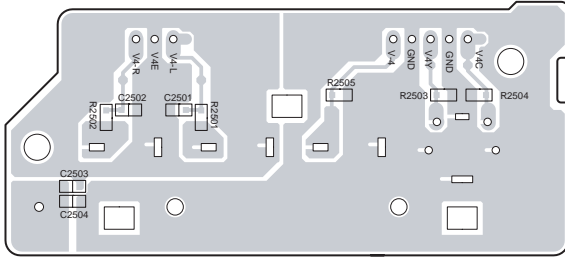

Soldering side

Front video PC board

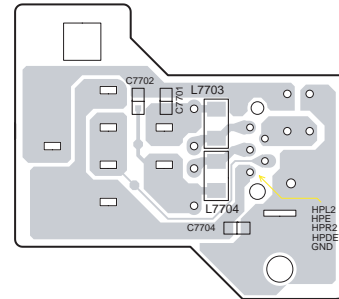

Soldering side

Headphone terminal PC board

3

4

U11

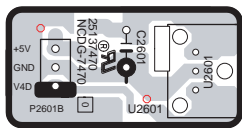

Component side

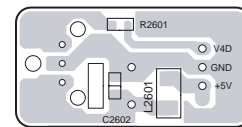

Soldering side

5

Front optical input PC board

A

B

C

D

PRINTED CIRCUIT BOARD VIEW 2-4
DSP section

1

2

3

4

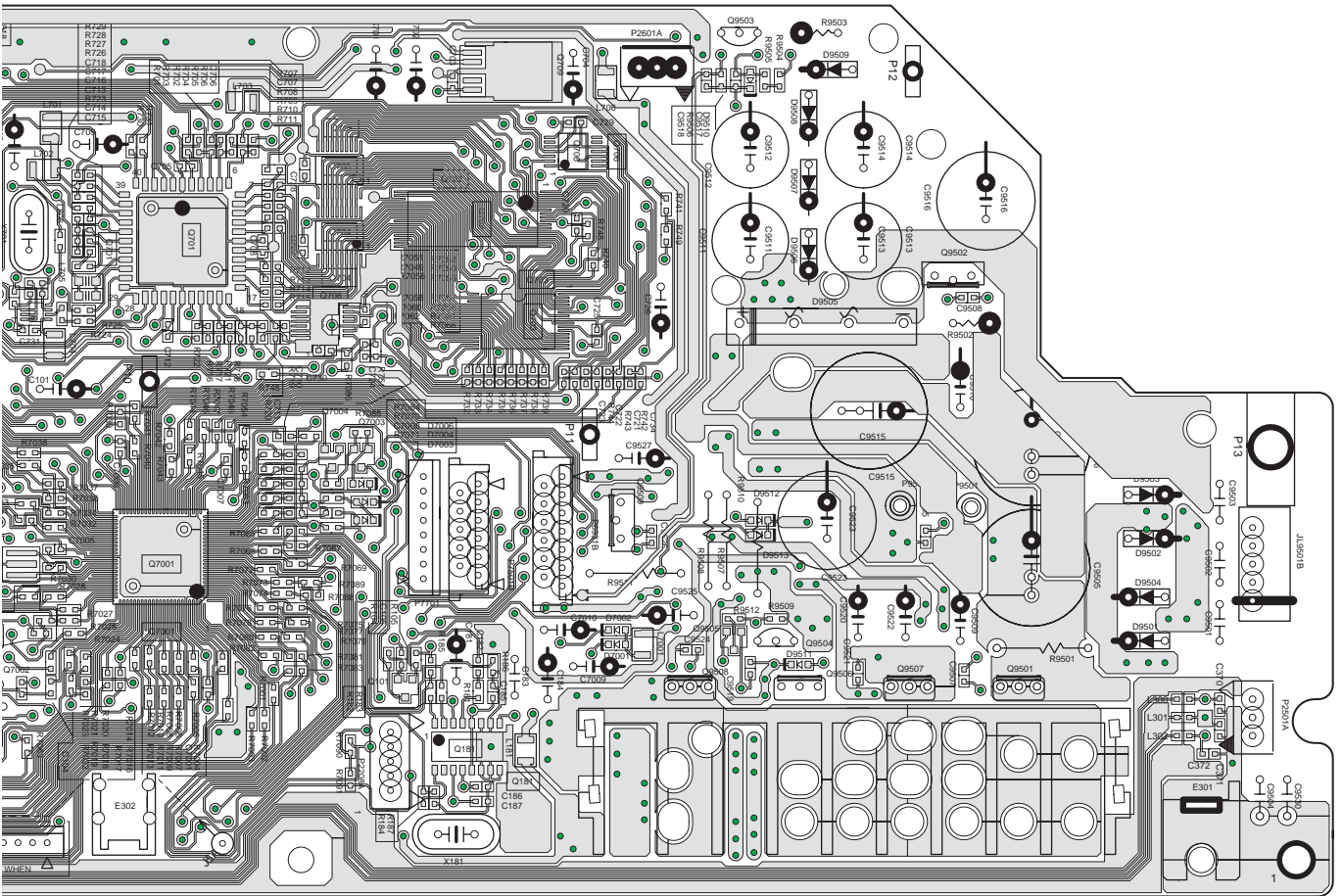

A

B

C

D

PRINTED CIRCUIT BOARD VIEW 2-2

DSP section

1

2

3

4

5

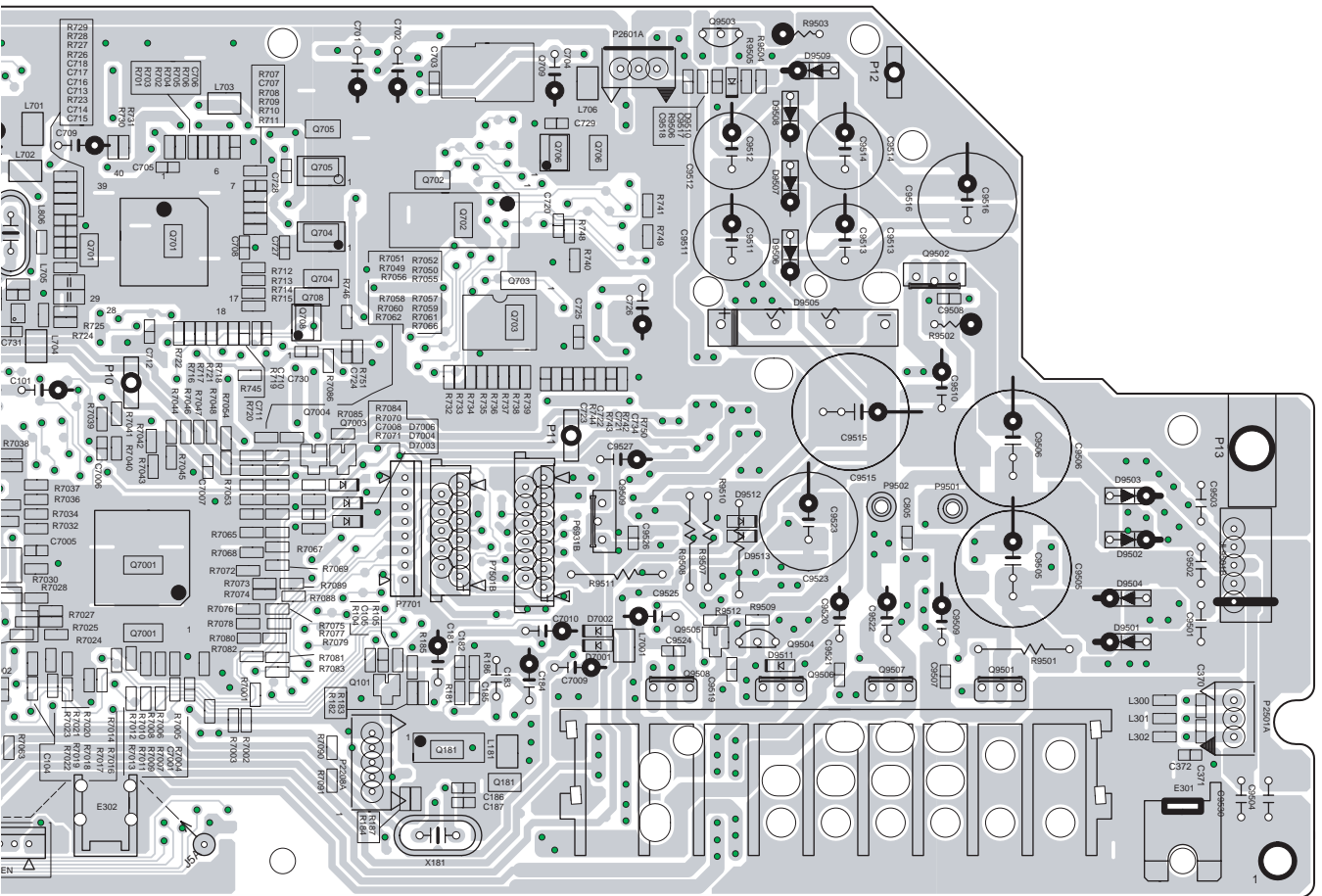

U1 Main circuit PC board

A B C D

PRINTED CIRCUIT BOARD VIEW 2-1

DSP section

1

2

3

4

5

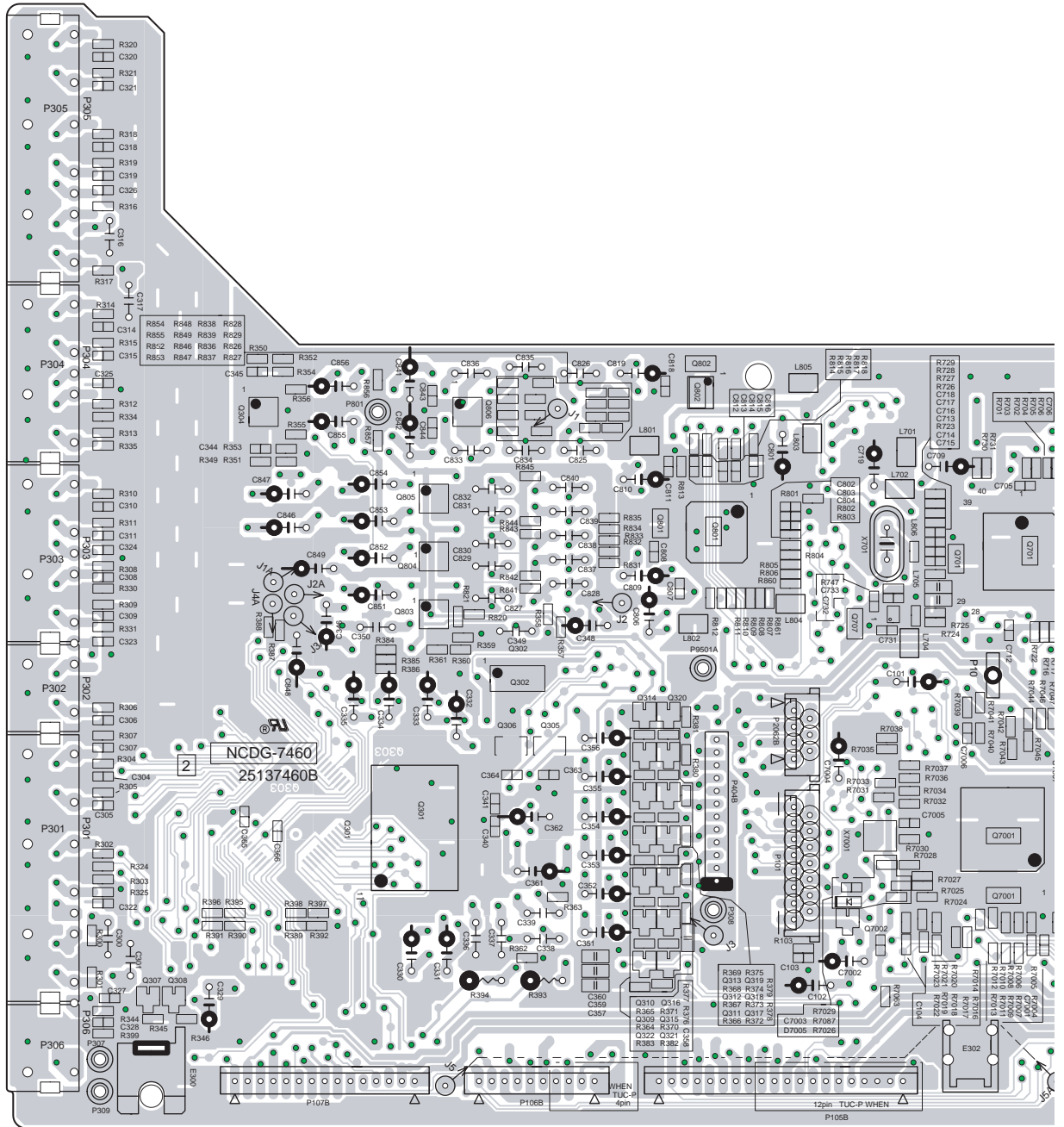

U1 Main circuit PC board

A B C D
PRINTED CIRCUIT BOARD VIEW FROM SOLDERING SIDE 1-1

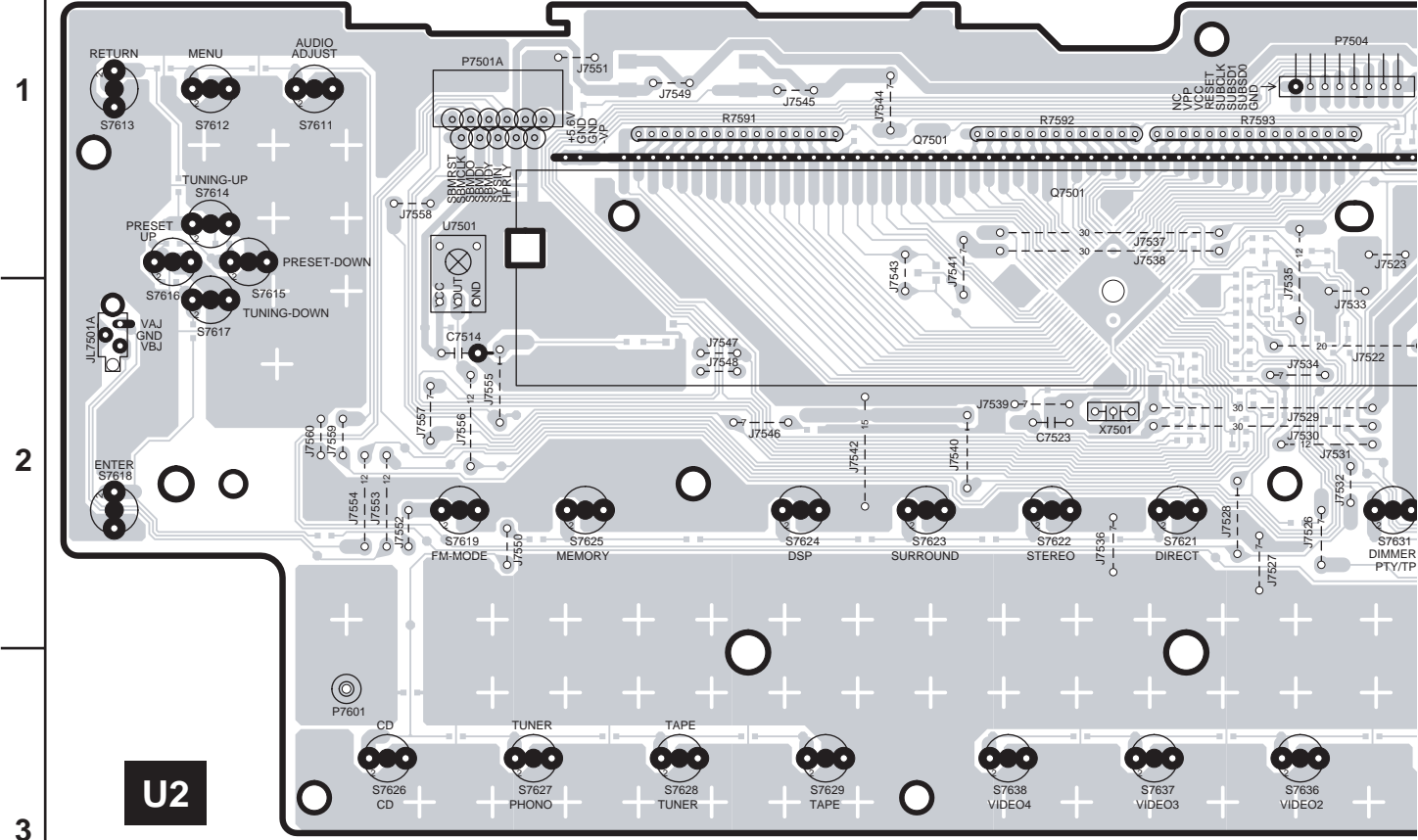

U2
Component side

Display circuit
PC board

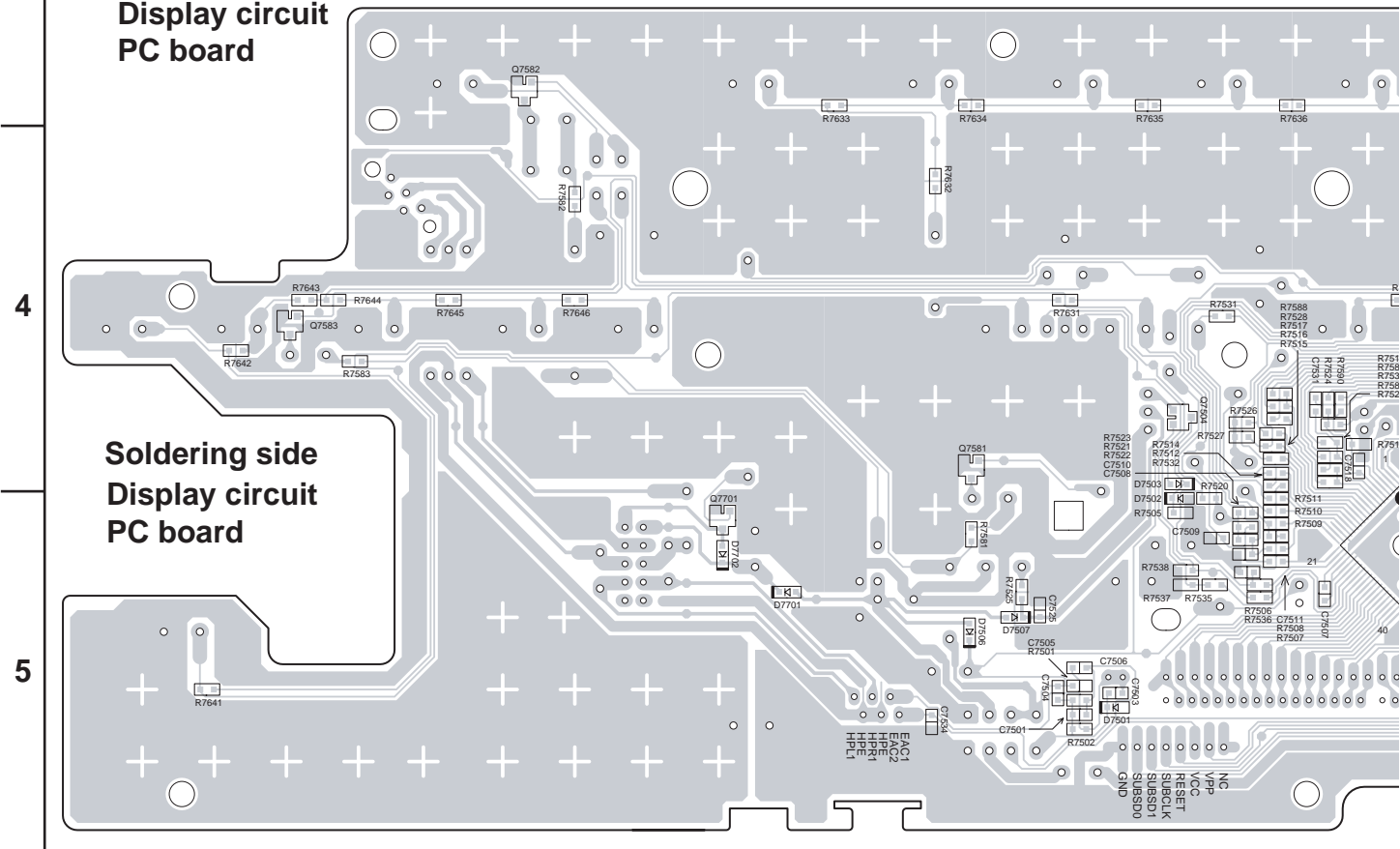

Soldering side
Display circuit
PC board

SUB MICROPROCESSOR-TERMINAL DESCRIPTION

Pin No.	Symbol	I/O	Description	Pin No.	Symbol	I/O	Description
1	VDD		Power supply terminal. Connect to 5V.	41	P22	O	Segment output terminal of P22.
2	VSS		Ground terminal.	42	P21	O	Segment output terminal of P21.
3	X1		Ceramic oscillator connection terminals for main system.	43	P20	O	Segment output terminal of P20.
4	X2		Connect the 5MHz ceramic oscillator between #3 and #4.	44	P19	O	Segment output terminal of P19.
5	IC/VPP		Internal connection terminal	45	P18	O	Segment output terminal of P18.
6	~RESET	I	System reset signal input terminal.	46	P17	O	Segment output terminal of P17.
7	SUBCL/SCK	I	Clock input terminal to transmit the signal from main microprocessor.	47	P16	O	Segment output terminal of P16.
8	SUBDO/SDI	I	Data input terminal to transmit the signal from main microprocessor.	48	P15	O	Segment output terminal of P15.
9	SUBDI/SDD	O	Data output terminal to transmit the signal to main microprocessor.	49	P14	O	Segment output terminal of P14.
10	SUBLDY	O	Data ready output terminal to transmit to the main microprocessor.	50	P13	O	Segment output terminal of P13.
11	VBJ	I	Pulse input terminal from the rotary encoder of volume.	51	P12	O	Segment output terminal of P12.
12	VAJ	I	Pulse input terminal from the rotary encoder of volume.	52	P11	O	Segment output terminal of P11.
13	SYSIN	I	System code input terminal.	53	P10	O	Segment output terminal of P10.
14	SYSOUT	I	System code output terminal.	54	P9	O	Segment output terminal of P9.
15	HPDET	I	Detection terminal of headphone insertion.	55	P8	O	Segment output terminal of P8.
16	~IRIN	I	Signal input terminal from the remote controller.	56	P7	O	Segment output terminal of P7.
17	STBYLED	O	Standby LED control output terminal.	57	P6	O	Segment output terminal of P6.
18	AVSS		Ground terminal for A/D converter.	58	P5	O	Segment output terminal of P5.
19	K0	I	Operation key connection terminal.	59	VDD2		Power supply terminal. Apply +5V.
20	K1	I	Operation key connection terminal.	60	VLOAD		Negative power supply terminal of FL controller.
21	K2	I	Operation key connection terminal.	61	P4	O	Segment output terminal of P4.
22	K3	I	Operation key connection terminal.	62	P3	O	Segment output terminal of P3.
23	VSS0		Ground terminal	63	P2	O	Segment output terminal of P2.
24	AVDD		Power supply terminal for A/D converter.	64	P1	O	Segment output terminal of P1.
25	VDDD		Power supply terminal. Apply +5V.	65	16G	O	Grid output terminal of 16G.
26	ZONE2LED	O	Not used.	66	15G	O	Grid output terminal of 15G.
27	PURELED	O	Not used.	67	14G	O	Grid output terminal of 14G.
28	P35	O	Segment output terminal of P35.	68	13G	O	Grid output terminal of 13G.
29	P34	O	Segment output terminal of P34.	69	12G	O	Grid output terminal of 12G.
30	P33	O	Segment output terminal of P33.	70	11G	O	Grid output terminal of 11G.
31	P32	O	Segment output terminal of P32.	71	10G	O	Grid output terminal of 10G.
32	P31	O	Segment output terminal of P31.	72	9G	O	Grid output terminal of 9G.
33	P30	O	Segment output terminal of P30.	73	8G	O	Grid output terminal of 8G.
34	P29	O	Segment output terminal of P29.	74	7G	O	Grid output terminal of 7G.
35	P28	O	Segment output terminal of P28.	75	6G	O	Grid output terminal of 6G.
36	P27	O	Segment output terminal of P27.	76	5G	O	Grid output terminal of 5G.
37	P26	O	Segment output terminal of P26.	77	4G	O	Grid output terminal of 4G.
38	P25	O	Segment output terminal of P25.	78	3G	O	Grid output terminal of 3G.
39	P24	O	Segment output terminal of P24.	79	2G	O	Grid output terminal of 2G.
40	P23	O	Segment output terminal of P23.	80	1G	O	Grid output terminal of 1G.

ADJUSTMENT AND CONFIRMATION PROCEDURES 2

3. Confirmation of Current detection circuit

Set the unit to "Test-1-00".

Connect the differentiating circuit and apply the 200Hz square signal to MULTI CHANNEL INPUT terminal of each channel.

Adjust the attenuator or Volume so that the output level becomes 35V p-p.

Confirm that the speaker relay does not turn OFF when a 3.0 ohm load is connected.

Confirm that the speaker relay turns off when a 1.5 ohm load is connected.

Caution: Don't continue more than 3 seconds.

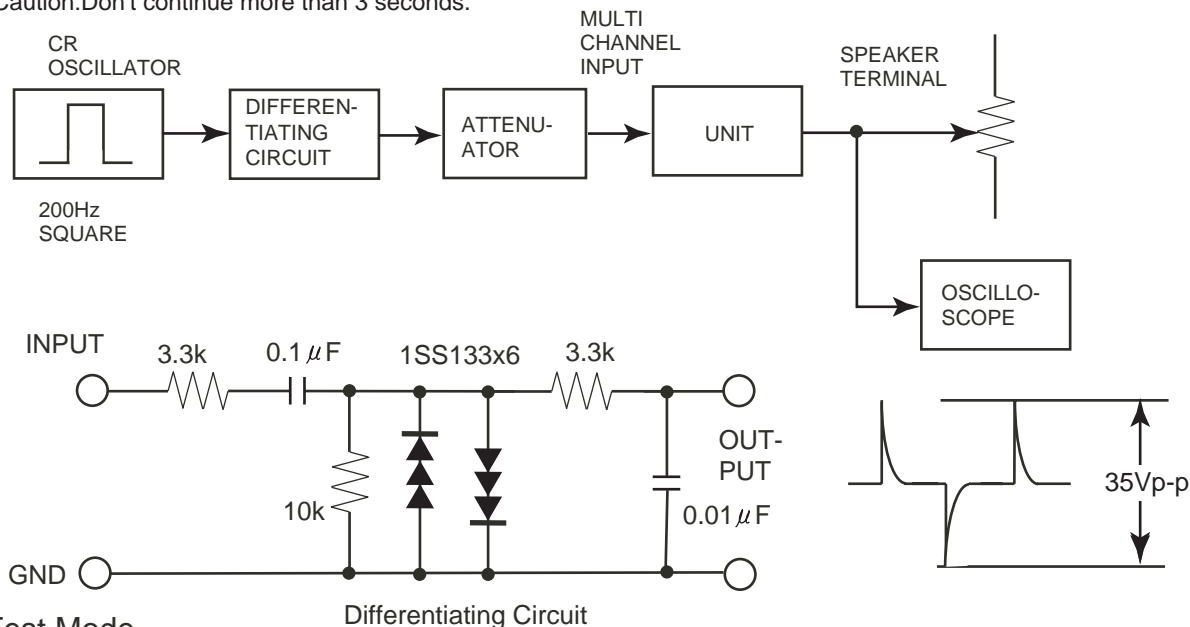

Test Mode

1. Turn POWER button on.
2. Press and hold down CD button, then press STANDBY/ON button.
3. After "Test-1" on the FL tube is displayed, press CD button to set the unit to the Test mode of FL tube.

Note: DVD:Test-1 VIDEO 1 :Test-2 SP-A: UP

VIDEO 2 :Test-3 VIDEO 3:Test-4 SP-B: DOWN

Test mode of FL tube

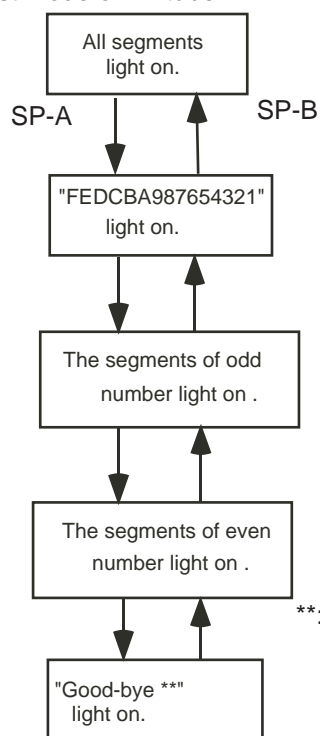

** : Region US:U.S.A.

EU:Europe

WR:Other models

Press POWER button to finish the Test mode of FL tube.

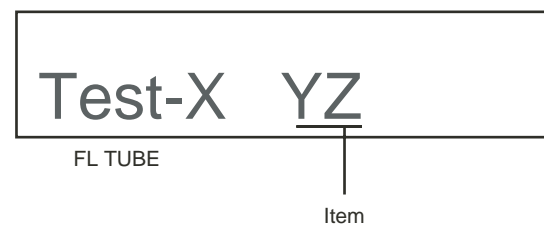

Confirmation of voltage sensor

1. Set the unit to Test-3-4.
2. Apply the signal 1kHz, -15dBV to the MULTI-CH input. Confirm that the FM STEREO is displayed. Confirm the all channels except SUBWOFFER.
3. When connect the resistor 2.7 kohm/1 W between the terminals COM and TH1 of P6301, confirm that "FM STEREO" light on.
Note: No input signal.
4. When set the unit to "Test-4-30, confirm that the speaker relays of RL6901 and RL6902 turn off.
Note: No input signal.

PACKING PROCEDURES

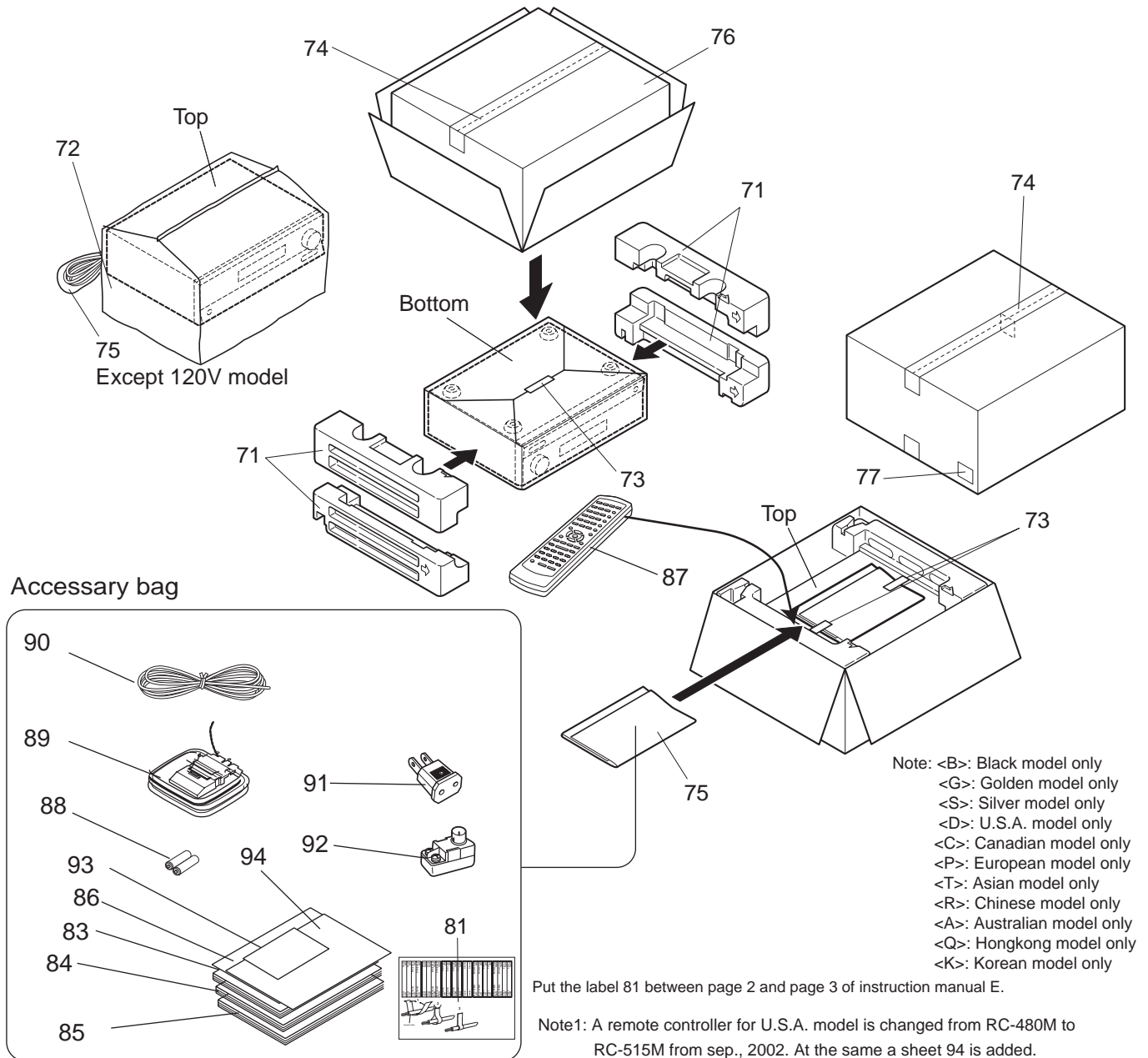

REF.NO.	PART NO.	DESCRIPTION	REF.NO.	PART NO.	DESCRIPTION
71	29092052	Pad	81	29363059A	Label,cable
72	29100153	1020x720,Polybag	83	29343298B	Instruction manual E
73	29110149	Tape,cellophane	84	29343300A	Instruction manual FSI <P/C>
74	29110148	PP tape		29343302A	Instruction manual CTCS <T/Q/R>
75	29100097-1A	350*250,Polybag	85	29343301A	Instruction manual GDSW <P>
76	29053880	Carton box <D>	86	29343299	Instruction manual,digist <D>
	29053881	Carton box <C/T/A>	87	24140480	RC-480M,Remote controller
	29053882	Carton box <P>		24140515	RC-515M,Remote controller <D> Note 1
	29053883	Carton box <S>	88	3010054	UM-3,Battery
	29053884	Carton box <G>	89	232140	NMA-3057,AM loop antenna
77	29363087	Label UPC <D/C>	90	292142	FM antenna <D/C>
	29363083	Label EAN <P>		292115	FM antenna <P/T/A/R/Q/K>
	29363084	Label EAN <S>	91	25056005	CV-K-1,Conversion plug <T>
	29363085	Label EAN <T/A>	92	25065462	YAE21-0237,Antenna adaptor <T/A/R/Q/K>
	29363086	Label EAN <G>	93	29365090A	Warranty card <D>
			94	29355408	Instruction sheet <D> Note 1

ONKYO CORPORATION

Sales & Product Planning Div. : 2-1, Nisshin-cho, Neyagawa-shi, OSAKA 572-8540, JAPAN
Tel: 072-831-8111 Fax: 072-833-5222

ONKYO U.S.A. CORPORATION

18 Park Way, Upper Saddle River, N.J. 07458, U.S.A.
Tel: 201-785-2600 Fax: 201-785-2650 E-mail: onkyo@onkyousa.com

ONKYO EUROPE ELECTRONICS GmbH

Liegnitzerstrasse 6, 82194 Grobenzell, GERMANY
Tel: +49-8142-4401-0 Fax: +49-8142-4401-555 E-mail: info@onkyo.de

ONKYO CHINA LIMITED

Units 2102-2107, Metroplaza Tower I, 223 Hing Fong Road, Kwai Chung,
N.T., HONG KONG Tel: 852-2429-3118 Fax: 852-2428-9039