

ONKYO SERVICE MANUAL

AV RECEIVER MODEL TX-SR601/E

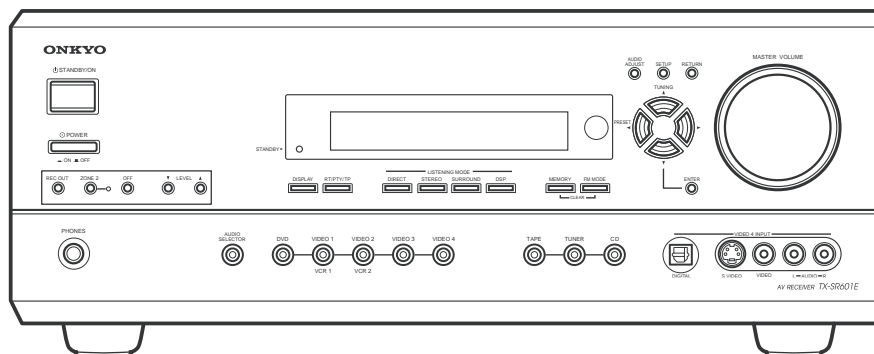

Black, Golden and Silver models

BMDD,BMDC,SMDC	120V AC, 60Hz
BMPP,SMPP,BMPA,SMPA	230-240V AC, 50Hz
BMWT,GMWT,GMWR,GMWQ	120/220-230V AC, 50/60Hz
GMGK	220-230V AC, 50Hz

SAFETY-RELATED COMPONENT WARNING!!

COMPONENTS IDENTIFIED BY MARK \triangle ON THE SCHEMATIC DIAGRAM AND IN THE PARTS LIST ARE CRITICAL FOR RISK OF FIRE AND ELECTRIC SHOCK. REPLACE THESE COMPONENTS WITH ONKYO PARTS WHOSE PART NUMBERS APPEAR AS SHOWN IN THIS MANUAL.

MAKE LEAKAGE-CURRENT OR RESISTANCE MEASUREMENTS TO DETERMINE THAT EXPOSED PARTS ARE ACCEPTABLY INSULATED FROM THE SUPPLY CIRCUIT BEFORE RETURNING THE APPLIANCE TO THE CUSTOMER.

AMPLIFIER SECTION

Continuous average power output (FTC)

All channels: **85 W per channel min. RMS at 8 Ω, 2 channels driven from 20 Hz to 20 kHz with no more than 0.08% total harmonic distortion.**
110 W min. RMS at 6 Ω, 2 channels driven from 1 kHz with no more than 0.1% total harmonic distortion.

Continuous power output (DIN) 120 W at 6 Ω
 Maximum power output (EIAJ) 150 W at 6 Ω
 Dynamic power output (stereo) 2 × 220 W at 3 Ω
 2 × 165 W at 4 Ω
 2 × 100 W at 8 Ω

Total harmonic distortion: 0.08% at rated power
 0.08% at 1 W output

IM distortion: 0.08% at rated power
 0.08% at 1 W output

Damping factor: 60 at 8 Ω

Input sensitivity and impedance
 LINE (CD, TAPE, DVD, VIDEO 1-4): 200 mV, 47 kΩ
 MULTICHANNEL INPUT (FRONT L/C/R, SURROUND L/R): 200 mV, 47 kΩ
 (SUBWOOFER): 36 mV, 47 kΩ
 COAXIAL (DIGITAL): 0.5 Vp-p, 75 Ω
 DVD, VIDEO 1, 2, 3, 4: 1 Vp-p, 75 Ω
 1 Vp-p, 75 Ω (Y)
 0.28 Vp-p, 75 Ω (C)

COMPONENT VIDEO 1, 2: 1 Vp-p, 75 Ω (Y)
 0.7 Vp-p, 75 Ω (PB, PR)

Output level and impedance
 Rec out (TAPE, VIDEO 1, 2): 200 mV, 470 Ω
 Line out: 100 mV, 470 Ω (Zone 2)
 Pre out: 1 V, 470 Ω

VIDEO (VIDEO 1, 2, MONITOR OUT): 1 Vp-p, 75 Ω
 1 Vp-p, 75 Ω (Y)
 0.28 p-p, 75 Ω (C)

COMPONENT VIDEO OUT: 1 Vp-p, 75 Ω (Y)
 0.7 Vp-p, 75 Ω (PB, PR)

Frequency response: 10 Hz to 100 kHz: +1/-3 dB
 (CD in Direct mode)

Tone control
 Bass: ±10 dB at 50 Hz
 Treble: ±10 dB at 20,000 Hz

Signal-to-noise ratio (stereo)
 CD/Tape: 106 dB (IHF A, 0.5 V input)
 Muting: -50 dB

TUNER SECTION
FM

Tuning range:
 USA & Canadian models: 87.50-108.00 MHz (100-kHz steps)
 Other area models: 87.50-108.00 MHz (50-kHz steps)

Usable sensitivity
 Mono: 11.2 dBf, 1.0 μV (75 Ω IHF)
 0.9 μV (75 Ω DIN)
 Stereo: 17.2 dBf, 2.0 μV (75 Ω IHF)
 23 μV (75 Ω DIN)

50 dB quieting sensitivity
 Mono: 17.2 dBf, 2.0 μV (75 Ω)
 Stereo: 37.2 dBf, 20 μV (75 Ω)

Capture ratio: 2.0 dB

Image rejection ratio
 USA & Canadian models: 40 dB
 Other area models: 85 dB

IF rejection ratio: 90 dB

Signal-to-noise ratio
 Mono: 76 dB
 Stereo: 70 dB

Alternate channel attenuation: 55 dB

Selectivity: 50 dB (DIN)

AM suppression ratio: 50 dB

Total harmonic distortion
 Mono: 0.2%
 Stereo: 0.3%

Frequency response: 30 Hz-15 kHz, ±1.0 dB

Stereo separation: 45 dB at 1 kHz
 30 dB at 100 Hz-10 kHz

AM

Tuning range
 USA & Canadian models: 530 to 1,710 kHz (10-kHz steps)
 European & Australian models: 522 to 1,611 kHz (9-kHz steps)
 Worldwide models: 522 to 1,611 kHz (9-kHz steps)
 530 to 1,710 kHz (10-kHz steps)

Usable sensitivity: 30 μV
 40 dB

Image rejection ratio: 40 dB

IF rejection ratio: 40 dB

Signal-to-noise ratio: 40 dB

Total harmonic distortion: 0.7%

GENERAL
Power supply

USA & Canadian models: AC 120 V, 60 Hz
 European & Australian models: AC 230-240 V, 50 Hz
 Some Asian models: AC 220-230 V, 50/60 Hz
 Worldwide models: AC 220-230 and 120 V switchable, 50/60 Hz

Power consumption

USA & Canadian models: 5.3 A
 Other models: 550 W

Dimensions (W × H × D): 435 × 175 × 431.5 mm
 17-1/8" × 6-7/8" × 16-15/16"

Weight

USA & Canadian models: 26.7 lbs.
 Other models: 12.9 kg

REMOTE CONTROLLER

Transmitter: Infrared
 Signal range: Approx. 16 ft., 5 meters
 Power supply: Two "AA" batteries (1.5 V × 2)

Specifications and features are subject to change without notice.

SERVICE PROCEDURES

1. Replacing the fuses



This symbol located near the fuses indicates that the fuse used is fast operating type. For continued protection against fire hazard, replace with same type fuse. For fuse rating refer to the marking adjacent to the symbol.



Ce symbole indique que le fusible utilise est a rapide. Pour une protection permanente, n'utiliser que fusibles de meme type. Ce dernier est la qu le present symbol est appse.

CIRCUIT NO.	PART NO.	DESCRIPTION
F6901,F6902	252196 or 252301	12A-UL/T-314 or 12A-TUL-250V, Fuse <D>
	252100 or 252307	10A-EAK or 10A-TL250V, Fuse <O>
F901	252199	10A-UL, Fuse <D/T/Q/R>
F902	252078, 252244 or 252278	5A-SE-EAK, 5A-SE-TL250V or 5A-SE-TL250V, Fuse <O>
	252164 or 252258	5A-UL/T-237 or 5A-T/UL-ST2,Fuse <D>
F903	252075, 252241 or 252275	2.5A-SE-EAK, 2.5A-SE-TL250V or 2.5A-SE-TL250V <O>
	252160 or 252254	2.5A-UL/T-237 or 2.5A-T/UL-ST2,Fuse <D>
	252075, 252241 or 252275	2.5A-SE-EAK, 2.5A-SE-TL250V or 2.5A-SE-TL250V, Fuse <O>

Note: <D>:120V model only
 <O>: Other models except 120V model
 <T>: Asian model only for 230V
 <R>: Chinese model only
 <Q>: Hongkong model only

2. To initialize the unit

This device employs a microprocessor to perform various functions and operations. If interference generated by an external power supply, radio wave, or other electrical source results in accident which causes the specified operations and functions to operate abnormally.

To perform a result, please follow the procedure below.

- 1.Press and hold down the VIDEO-1 button, then press the STANDBY/ON button.
- 2.After "CLEAR" is displayed, the preset memory and each mode stored in the memory, such as surround, are initialized and will return to the factory setting.

3. Safety-check out

(U.S.A. model only)

After correcting the original service problem, perform the following safety check before releasing the set to the customer.

Leakage Current Check

Measure leakage current to a known earth ground(water pipe, conduit, etc.) by connecting a leakage current tester between the earth ground and exposed metal parts of the appliance (input/output terminals, screwheads,metal overlays, etc.). Plug the power supply cord directly into a 120V AC 60 Hz outlet and turn Standby switch on. Any current measured must not exceed 0.5mA.

4.Setting the voltage selector (Worldwide models only)

Worldwide models are equipped with a voltage selector to conform with local power supplies. Be sure to set this switch to match the voltage of the power supply in your area before plugging in the unit.

Determine the proper voltage for your area: 220-230 V or 120 V. If the preset voltage is not correct for your area, insert a screwdriver into the groove in the switch. Slide the switch all the way to the upper (120 V) or to the lower (220-230 V), whichever is appropriate.

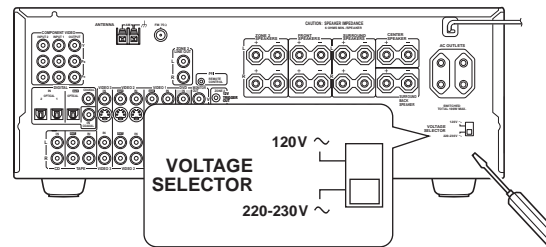

5.Setting the AM tuning step frequency (Worldwide models only)

To display the Hardware Config menu:

1. Display the main menu.
2. Use the ▲ and ▼ cursor buttons to select "1. Hard Config" and then press the ENTER button. The "Hardware Config" menu appears.

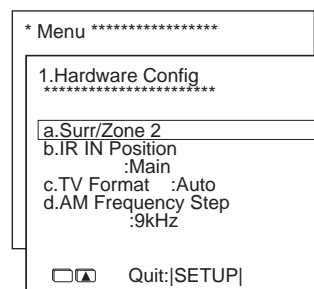

d. AM Frequency Step

This setting only appears on the worldwide model.

It determines the increment amount or decrement amount when adjusting the AM tuner frequency.

The initial setting is 9 kHz, and this needs only to be changed if you are using the unit in a 10-kHz region.

Here is an explanation of the controls and displays on the front panel of the TX-SR701/701E/601/601E.

Front panel

<TX-SR701E>

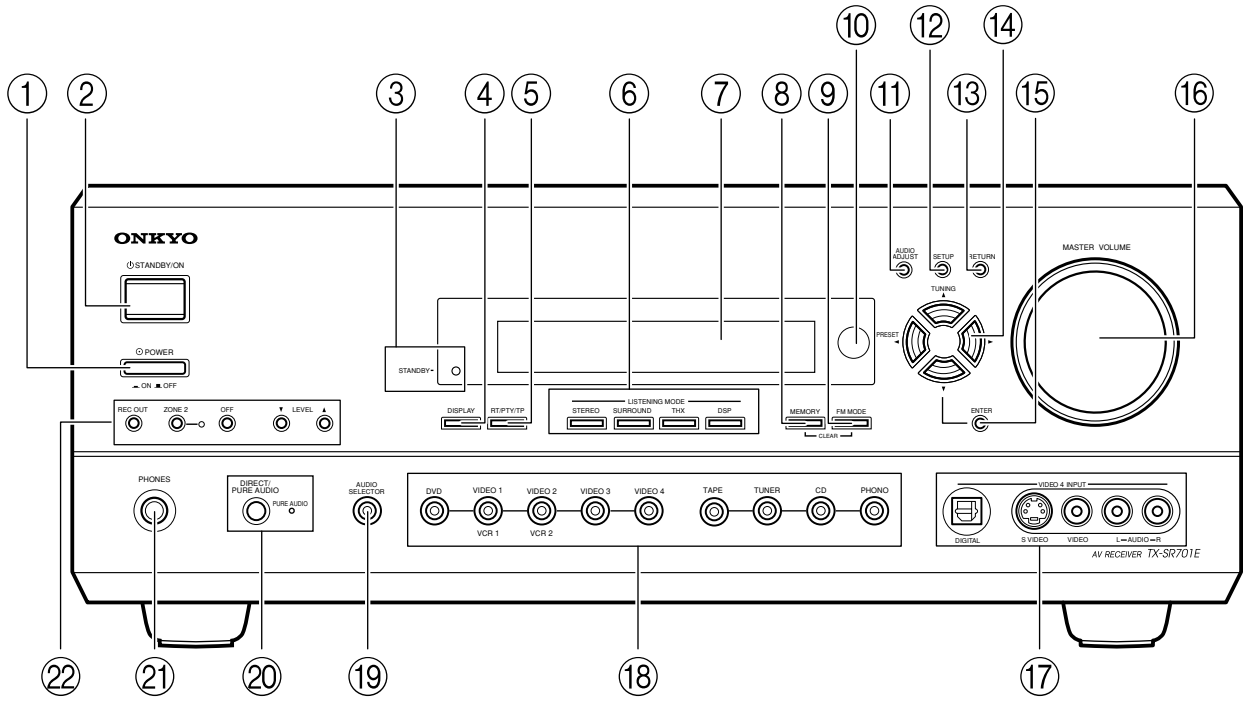

<TX-SR601E>

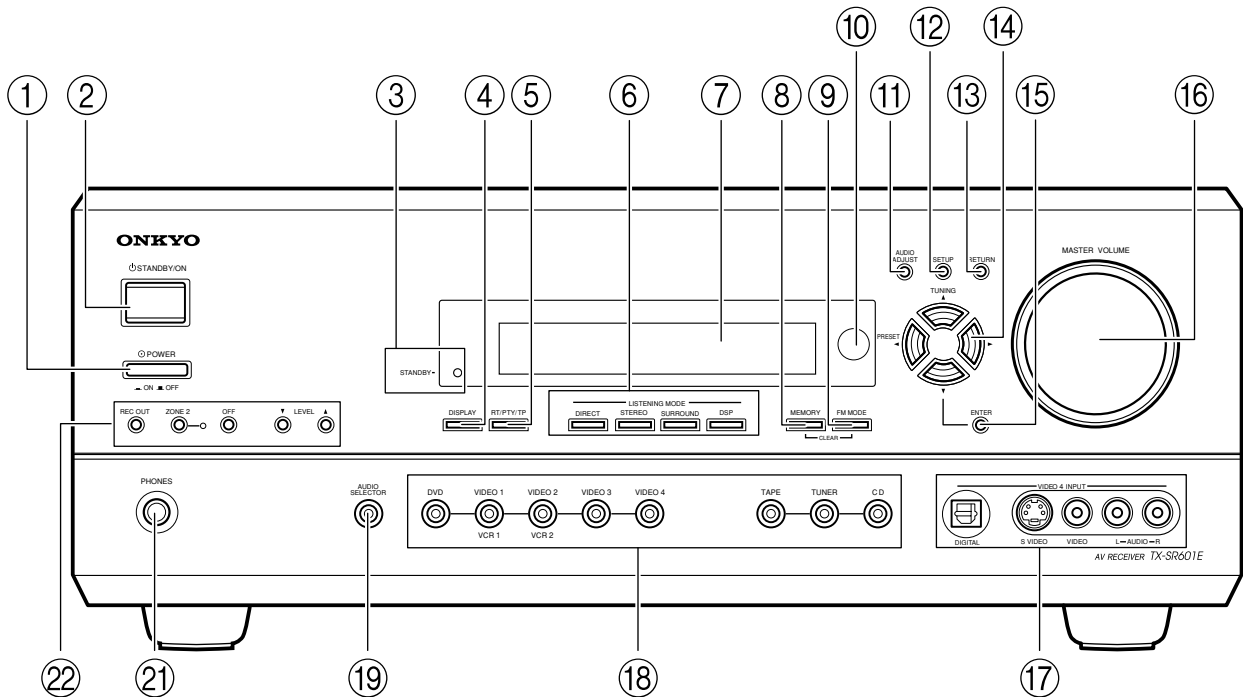

1 POWER switch (for all models other than USA and Canadian models, and Australian models)

Press to turn on and off the main power supply for the TX-SR701/701E/601/601E. When the TX-SR701/701E/601/601E is turned on with the POWER switch, the STANDBY indicator lights.

- Before turning on the power, check to make sure that all cords are properly connected.
- When the power is turned on, a sudden surge of current will occur that may adversely affect the operation of other devices. To prevent this, do not plug the TX-SR701/701E/601/601E into the same circuit used by sensitive equipment, e.g., computers.

2 STANDBY/ON button

If pressed with the POWER switch turned on (with the receiver plugged in for US models and Australian models), the TX-SR701/701E/601/601E turns on and the display lights up. If pressed again, the TX-SR701/701E/601/601E returns to the standby state. In the standby state, the display is turned off and the TX-SR701/701E/601/601E cannot be operated.

3 STANDBY indicator

Lights when the TX-SR701/701E/601/601E is in the standby state and when a signal is received from the remote controller.

4 DISPLAY button

Press to display information about the current input source signal. Each time you press the display button, the screen changes to show you different information concerning the input signal.

5 RT/PTY/TP (European models only) button

This button is only available on European models. Press this button to tune into the Radio Data System (RDS) for FM broadcasting. RDS was developed within the European Broadcasting Union (EBU) and is available in most European countries. Each time the button is pressed, the display changes from RT (radio text) to PTY (program type) to TP (traffic program) and then back to RT again.

5 DIMMER button (other than European models)

Press to set the brightness of the front display. There are three settings available: normal, dark, and very dark.

- The brightness of the front display can also be adjusted using the remote controller.

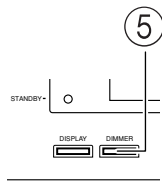

6 LISTENING MODE buttons

Press these buttons to select a listening mode for the current input source. Press the DIRECT (TX-SR601/601E), THX (TX-SR701/701E), STEREO, and SURROUND buttons to select a listening mode directly. Press the DSP button to select any of the possible listening modes for the input source currently selected.

Note:

During playback of a multichannel source, press the DIRECT button to turn off the tone control and the SURROUND button to turn on the tone control.

7 Front display

8 MEMORY button

Press to assign the radio station that you are currently tuned into to a preset channel or press to delete a previously preset station.

9 FM MODE button

Press to change the stereo mode from AUTO to MONO and vice versa. Each time this button is pressed, the AUTO indication turns on and off indicating the current mode. If you are listening to an FM radio station in stereo and the sound cuts out or there is a great deal of noise, switch from AUTO to MONO.

10 Remote control sensor

11 AUDIO ADJUST button

Press to adjust the sound quality and the listening mode.

12 SETUP button

Press to enter the Setup Menu. The OSD Menu will appear on the TV monitor as well as the front display on the TX-SR701/701E/601/601E.

13 RETURN button

When in the Setup Menu, press to go back one level. If pressed while at the Main Menu, you will exit the Setup Menu.

14 TUNING ▲/▼, PRESET ◀/▶, cursor (▲/▼/◀/▶) buttons

To tune into a radio station, press the TUNING ▲/▼ buttons. The tuner frequency is displayed in the front display and it can be changed in 100-kHz (or 50-kHz) increments for FM and 10-kHz (or 9-kHz) increments for AM.

When FM is selected as the input source, you can hold down either the TUNING ▲ or ▼ button and then release it to activate the auto-search feature. It will search for a station in the direction of the button you pressed and stop when it tunes into one. When navigating through the menu settings, these buttons move the cursor up or down (or change the highlighted item).

To select a radio station that was stored using the MEMORY button, press the PRESET ◀/▶ buttons.

When navigating through the menu settings, these buttons select the value or item that you selected with the TUNING ▲/▼ buttons.

When you press the SETUP button, the TUNING and PRESET buttons become cursor buttons to be used for Setup Menu operations.

15 ENTER button

Press to display the screen for the item that is selected in the Setup Menu.

16 MASTER VOLUME dial

Use to control the volume in the main zone. The volume for the remote zone (Zone 2) is independent.

17 VIDEO 4 INPUT terminals

For connecting a video camera or game device.

Front panel facilities

⑱ **Input source buttons (DVD, VIDEO 1–4, TAPE, TUNER, CD, and PHONO (TX-SR701/701E only))**

These buttons are used to select the input source.

Press these buttons to select the input source for the main zone.

To select the input source for the remote zone (Zone 2) or recording out (Rec Out), first press the ZONE 2 or REC OUT button, and then press the desired input source button. The input channel with its indicator lit red is output to REC OUT and the one with its indicator lit green is output to ZONE 2.

⑲ **AUDIO SELECTOR button**

Press to select the type of audio input signal.

⑳ **DIRECT/PURE AUDIO button and indicator (TX-SR701/701E only)**

㉑ **PHONES jack**

This is a standard stereo jack for connecting stereo headphones.

㉒ **REC OUT, ZONE 2, OFF, LEVEL ▼ / ▲ buttons, and ZONE 2 indicator**

The REC OUT and ZONE 2 buttons allow you to use the TX-SR701/701E/601/601E to output to a remote zone (Zone 2) or to another component for recording (Rec Out).

To turn off the output, press the OFF button. The ZONE 2 indicator lights when a signal is output to the remote zone (Zone 2). When the ZONE 2 indicator is off, then either output to the remote zone is turned off or Rec Out is selected. Press the LEVEL ▼ / ▲ buttons to enter the mode for adjusting the volume in the remote zone (Zone 2).

Note:

The Rec Out and Zone 2 buttons use the same circuit and therefore cannot be used at the same time. When REC OUT is selected, nothing is output to Zone 2. When ZONE 2 is selected, REC OUT is automatically fixed to SOURCE.

Front panel facilities

Front panel display

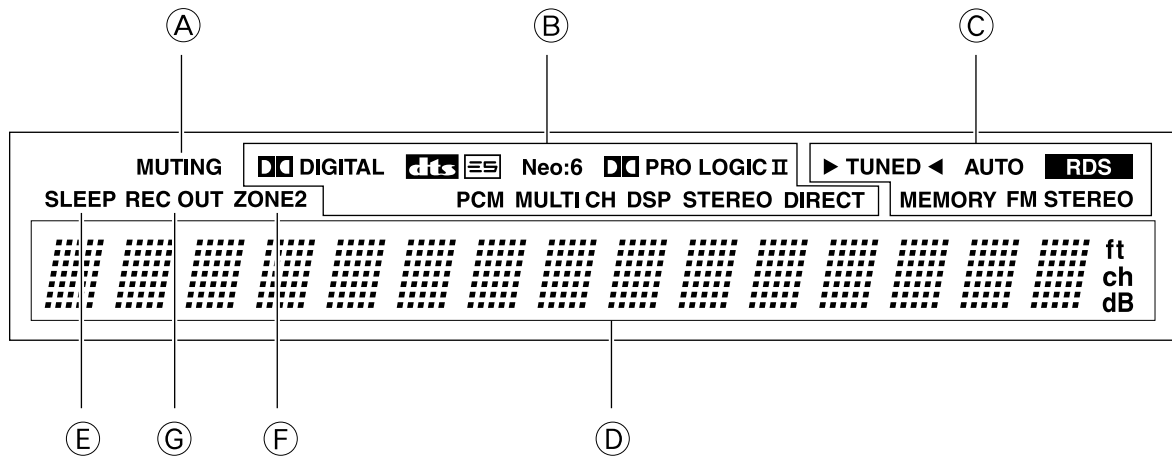

Ⓐ MUTING indicator

Flashes when the mute function is turned on.

Ⓑ Listening mode or digital input format indicators

One of these indicators lights to show the format of the current input source. In addition, one of the listening mode indicators lights to indicate the current listening mode.

Ⓒ Tuning indicators

TUNED indicator

Lights when a radio station is received.

AUTO indicator

Lights when receiving FM broadcasts in the stereo mode. Turns off when placed into the monaural mode.

RDS indicator (European models only)

Lights when an RDS station is received.

MEMORY indicator

Lights when the MEMORY button is pressed to preset a radio station.

FM STEREO indicator

Lights when an FM broadcast station is received in stereo.

Ⓓ Multi function display

During normal operation, shows the current input source and volume. When the FM or AM input is selected, shows the frequency and preset number. When the DISPLAY button is pressed, shows the listening mode and input source format. However, does not show the source format when the FM or AM source is selected.

Ⓔ SLEEP indicator

Lights when the sleep timer is turned on.

Ⓕ ZONE 2 indicator

Lights when using the remote zone (Zone 2).

Ⓖ REC OUT indicator

Lights when recording the input source from one component to another (Rec Out)

Rear panel

TX-SR701/701E

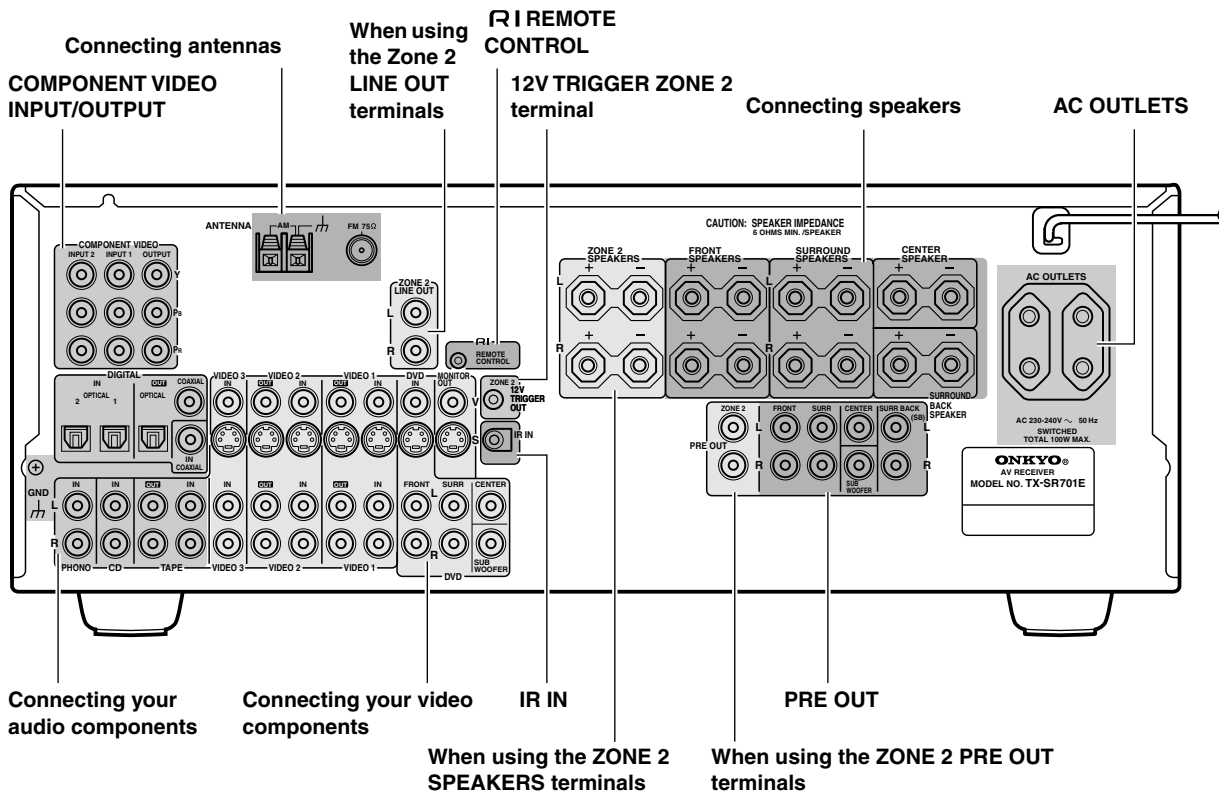

TX-SR601/601E

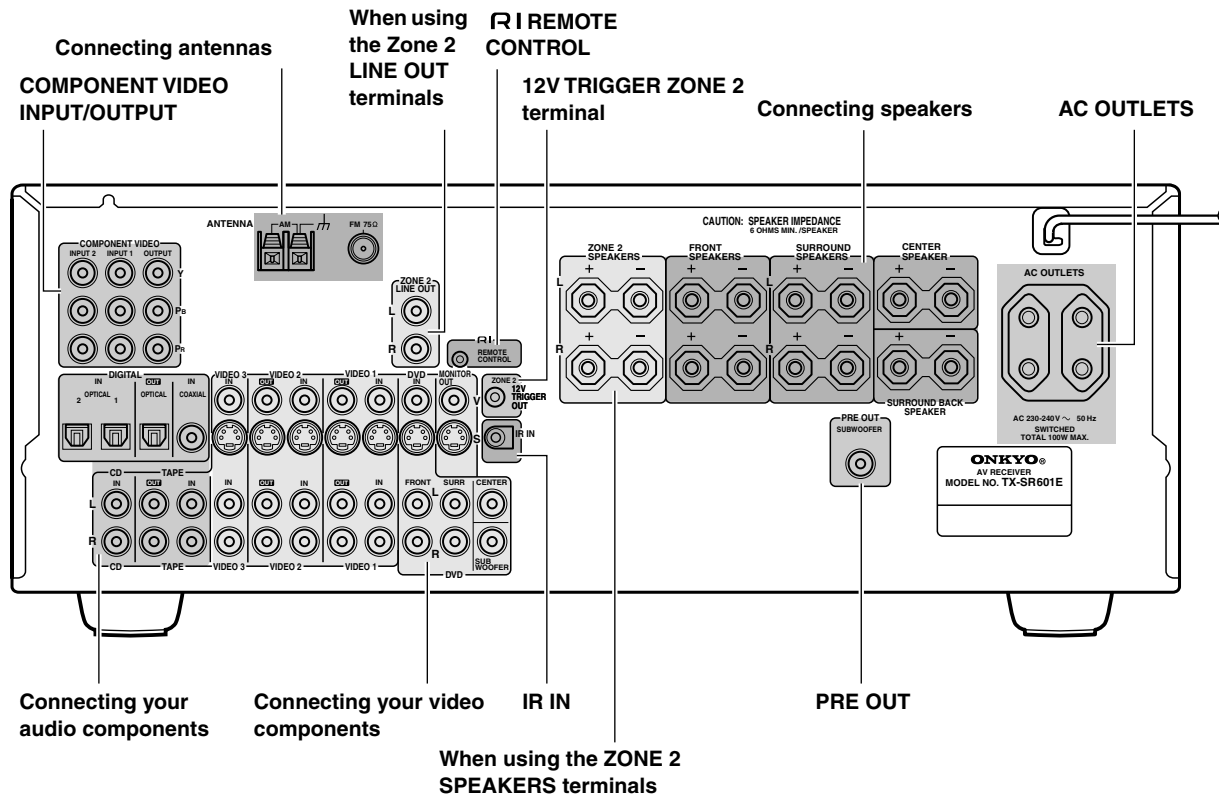

RC-533M

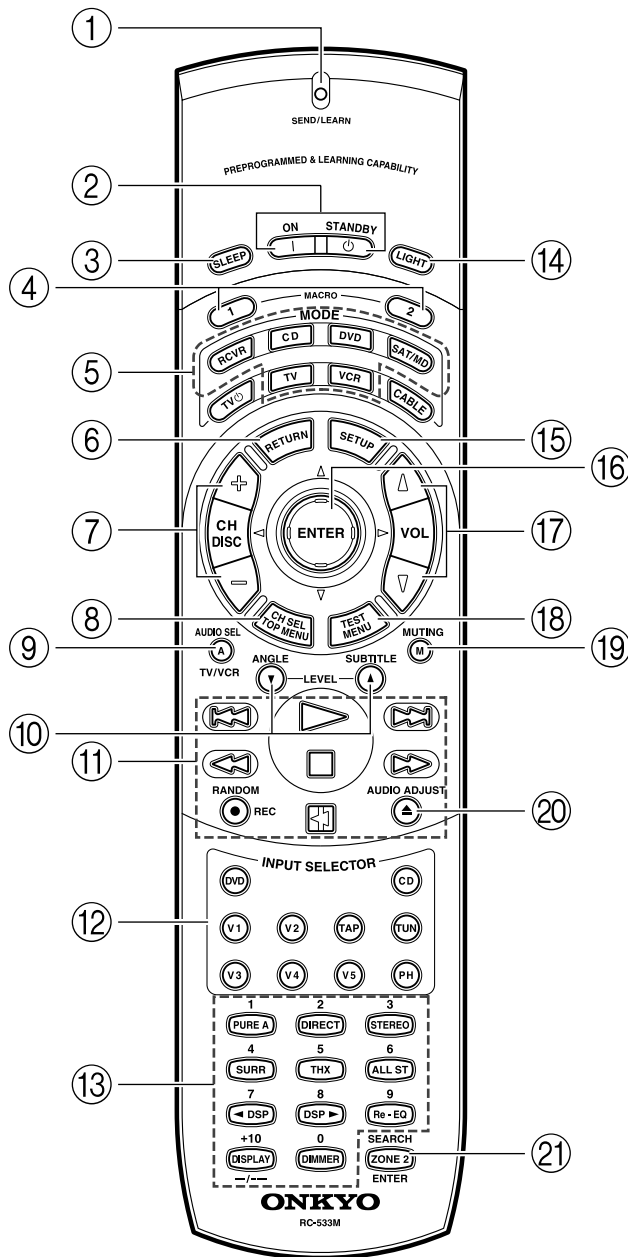

RC-515M

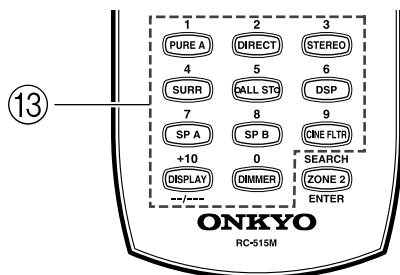

1 SEND/LEARN indicator

Lights red when signals are sent by the remote controller. It also flashes when a button is pressed when the battery power is low.

2 ON/STANDBY button

ON: Press to turn on the TX-SR701/701E/601/601E.

STANDBY: Press to place the TX-SR701/701E/601/601E in the standby state.

Be aware that pressing the STANDBY button only places the TX-SR701/701E/601/601E in standby and does not turn the power completely off.

3 SLEEP button

Press to set the sleep function.

The SLEEP button enables you to set the TX-SR701/701E/601/601E to turn off automatically after a specified time period.

4 MACRO 1, 2 button

Press to program or execute the macro function.

5 MODE buttons and indicators

Press to select the component to be operated by the remote controller. When a MODE button is pressed, it will light for 8 seconds. The selected MODE button will also light whenever any other operation button is pressed.

6 RETURN button

Press to enter the selected setting and return to the previous menu.

7 CH +/-, DISC +/- button

Press to select a preset channel for the tuner (CH).

When the CD mode is selected, also press to select a disc when operating components with disc changers (DISC).

8 CH SEL/TOP MENU button

Press to select a speaker channel when adjusting the speaker level (CH SEL).

When the DVD mode is selected, press to display the menu screens of the DVD player (TOP MENU).

9 AUDIO SEL/TV/VCR button

Press to select the audio input signal. The setting changes from "Auto" to "Multich" (only if DVD is selected as the input source) to "Analog" and back each time this button is pressed.

10 LEVEL +/-/ANGLE and LEVEL +/-/SUBTITLE buttons

Press to adjust the volume of the speaker selected using the CH SEL button (LEVEL +/-).

Press the ANGLE button to select a camera angle when playing a DVD-Video with multiple angle playback.

Press the SUBTITLE button to select a subtitle language when playing a DVD-Video.

11 CD/TAPE/DVD/MD operation buttons

Press to operate other Onkyo components connected to the TX-SR701/701E/601/601E using the **RI** terminals.

⑫ INPUT SELECTOR buttons

Press to select an input source.

Same as the input selector buttons on the front panel of the TX-SR701/701E/601/601E. The input source for each button is given here. DVD:DVD, CD:CD, V1:VIDEO1, V2:VIDEO2, V3:VIDEO3, V4:VIDEO4, V5:VIDEO5 (not used with the TX-SR701/701E/601/601E), TAP:TAPE, TUN:FM/AM, PH:PHONO (not used with the TX-SR601/601E).

⑬ Numeric key/Listening mode, SP A, SP B, CINE FLTR, DISPLAY, DIMMER buttons

1 to 9, +10, --/--, 0: For entering the number of a track.

PURE A:

TX-SR601/601E: Not used with the TX-SR601/601E.

TX-SR701/701E: Press to select the Pure Audio mode.

DIRECT, STEREO, SURR, ALL ST, DSP (TX-SR601/601E), DSP ◀▶ (TX-SR701/701E), THX (TX-SR701/701E): You can select a listening mode.

Note:

During playback of a multichannel source, press the DIRECT button to turn off the tone control and the SURR button to turn on the tone control.

SP A, SP B: Not used with the TX-SR601/601E.

CINE FLTR (TX-SR601/601E): Depending on the listening mode, you can turn the CinemaFILTER function on or off.

Re-EQ (TX-SR701/701E): Depending on the listening mode, you can turn the Re-EQ function on or off.

DISPLAY: For changing the display in the front display.

DIMMER: Adjusts the display brightness.

There are three settings available: normal, dark, and very dark.

⑭ LIGHT button (RC-533M only)

Press to turn on and off the lights in the buttons of the remote controller.

⑮ SETUP button

Press to display the Setup Menu on the TV screen and in the display. Press again to exit the menu.

⑯ ▲/▼/◀▶, ENTER button

When in the Setup Menu, press the upper and lower arrow buttons to select an item, press the right and left arrow buttons to select parameter values or modes, and press the ENTER button to advance to the next item.

⑰ VOL Δ/∇ button

Press to adjust the volume.

⑱ TEST/MENU button

This button is used to set the speaker output levels. Use this button in conjunction with the LEVEL ▲/▼ and CH SEL buttons to calibrate the speakers levels without entering the Setup Menu. [43]

When the DVD mode is selected, press to display the DVD menu (MENU).

⑲ MUTING button

⑳ AUDIO ADJUST button

㉑ ZONE 2/SEARCH/ENTER button

When the DVD mode is selected, press to find the specific section on a DVD where you want to start playback (SEARCH).

When in the RCVR mode, press to perform operations on the remote zone (ZONE 2).

When in the MD mode, press to enter the selected song (ENTER).

Check that the following accessories are supplied with the TX-SR701/701E/601/601E.

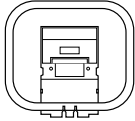

AM loop antenna × 1

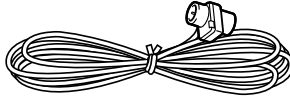

FM indoor antenna × 1

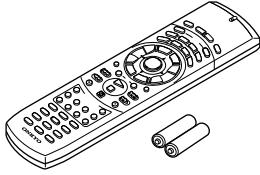

Remote controller × 1
TX-SR701/701E: RC-533M
TX-SR601/601E: RC-515M
Batteries (AA, R6) × 2

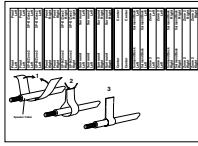

Speaker cable label × 1

The following accessories may be available depending on the area which it was purchased.

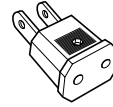

Conversion plug × 1

(Use this plug if the power cord plug of the TX-SR701/701E/601/601E does not fit your AC outlet. Shape may vary depending on the area which it was purchased.)

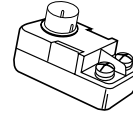

75/300 Ω antenna adapter × 1

EXPLODED VIEW

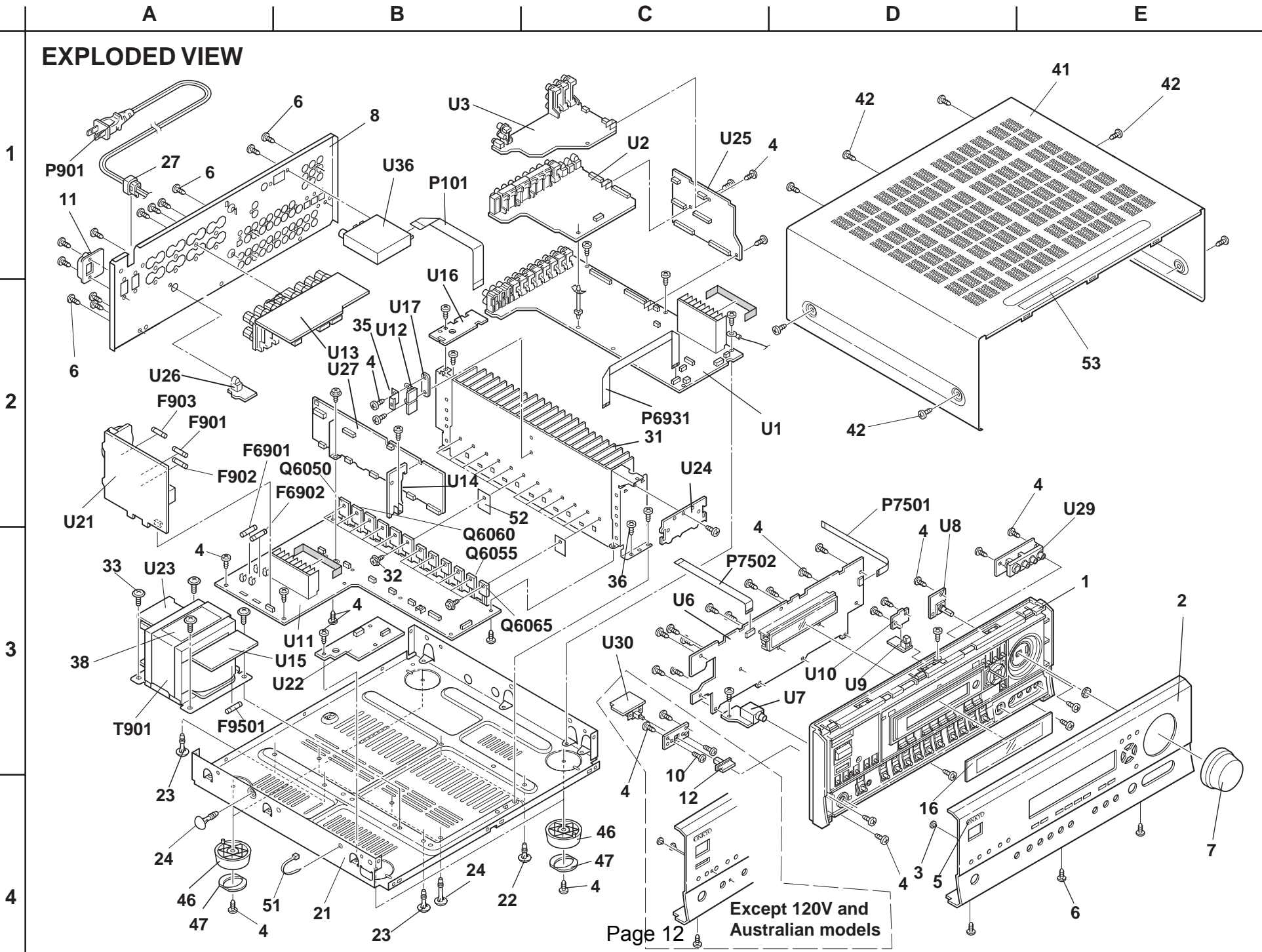

A **B** **C** **D**

BLOCK DIAGRAM

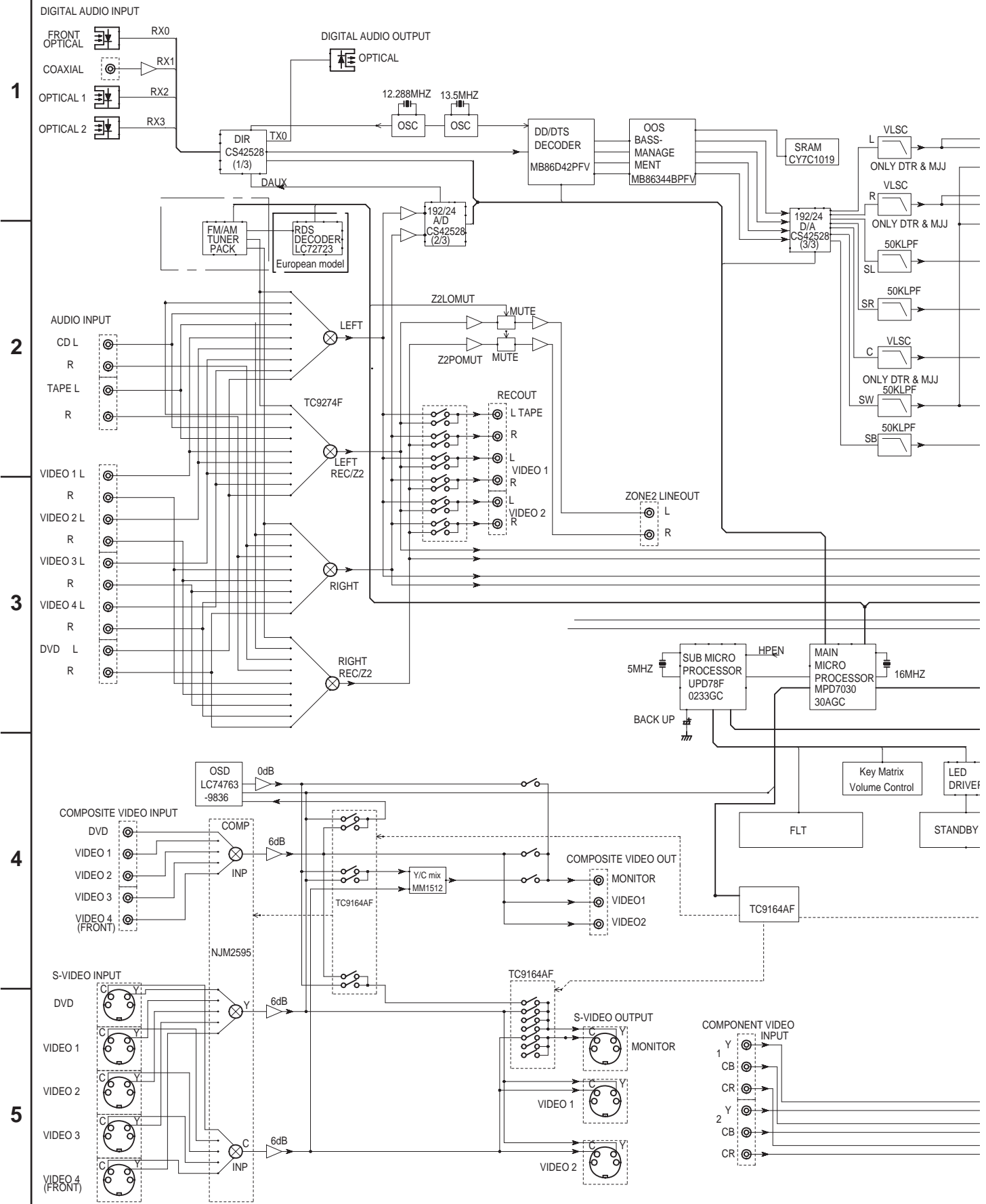

BLOCK DIAGRAM

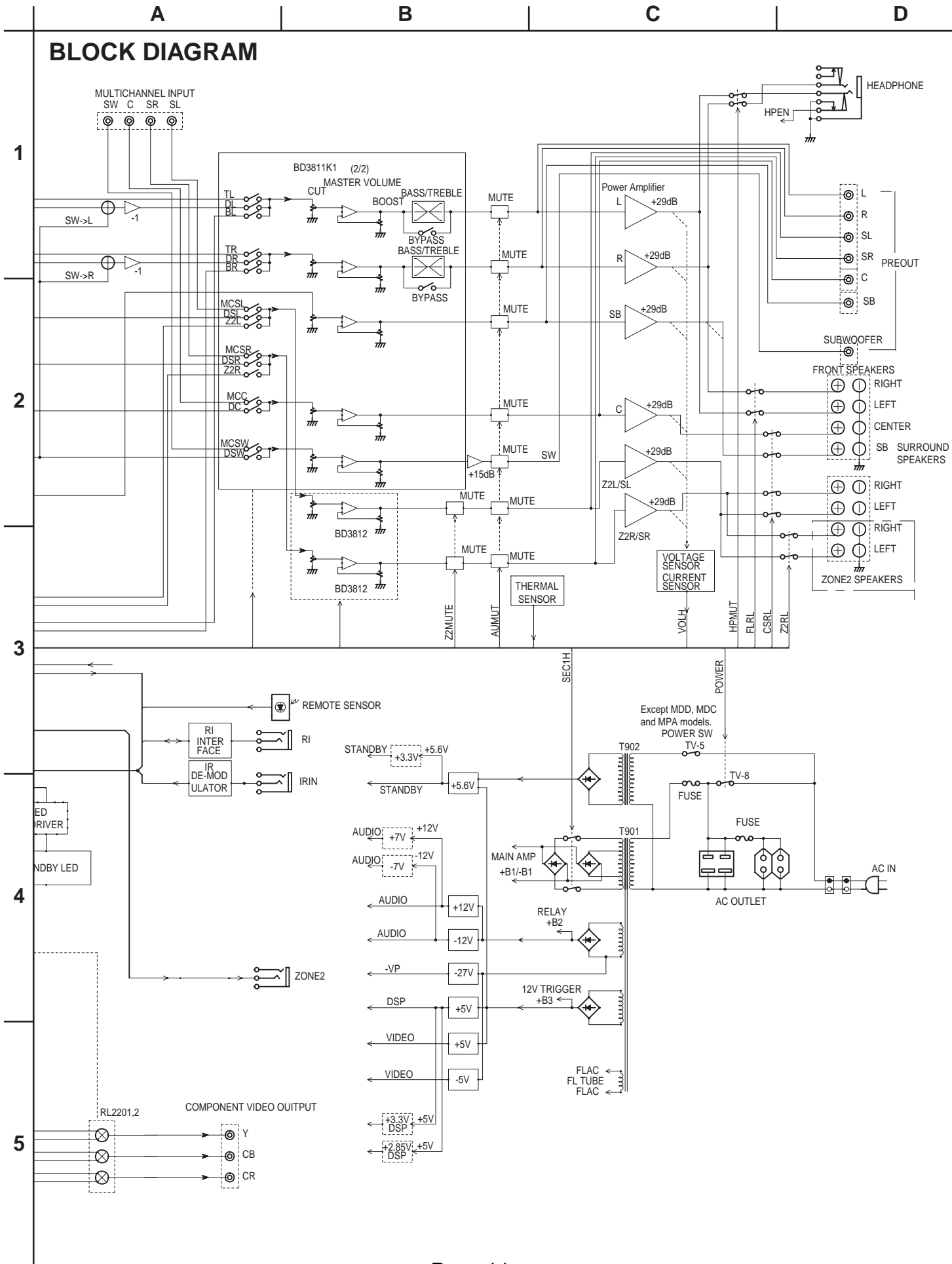

SCHEMATIC DIAGRAM 1

Front panel section

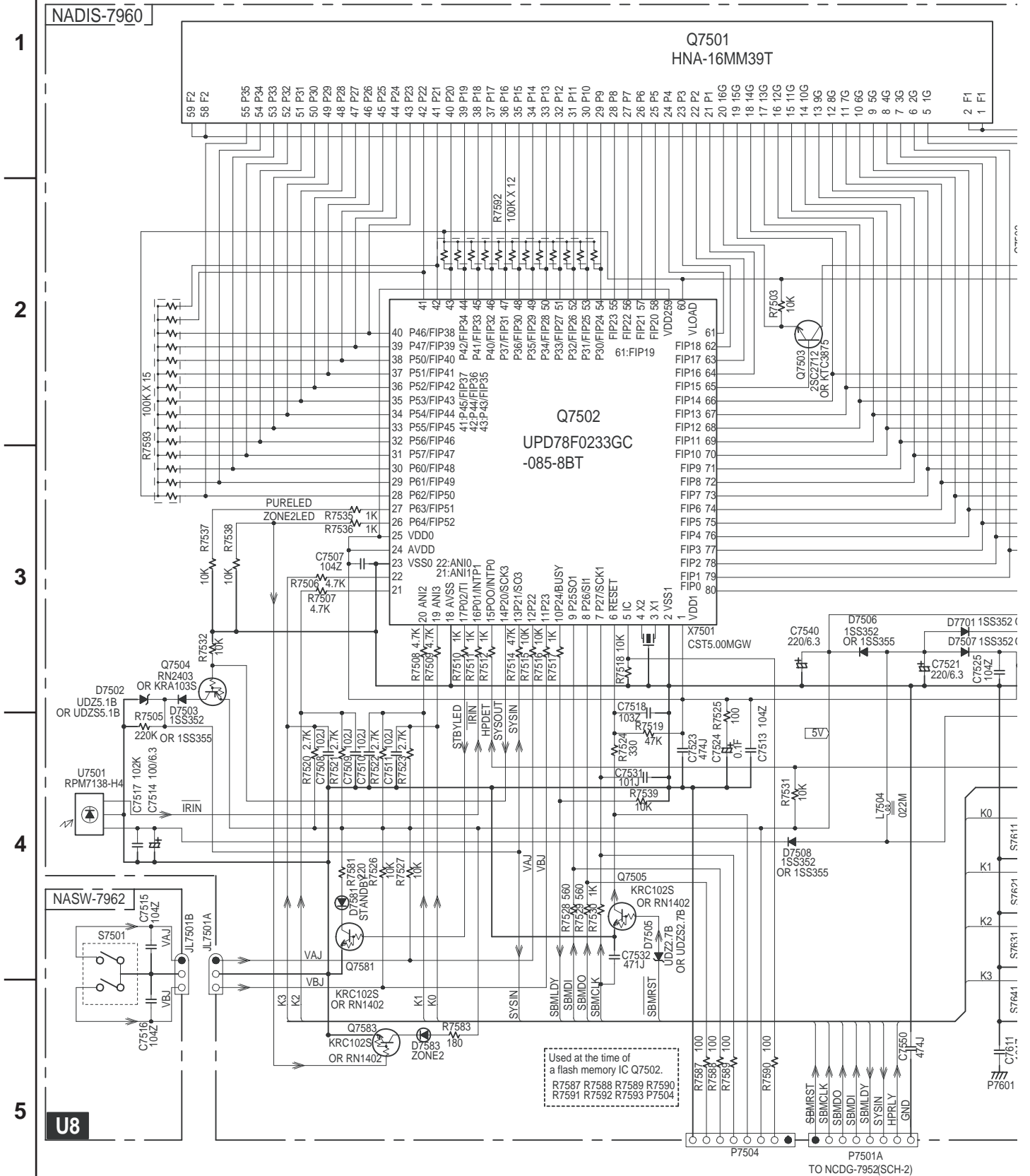

SCHEMATIC DIAGRAM 1

Front panel section

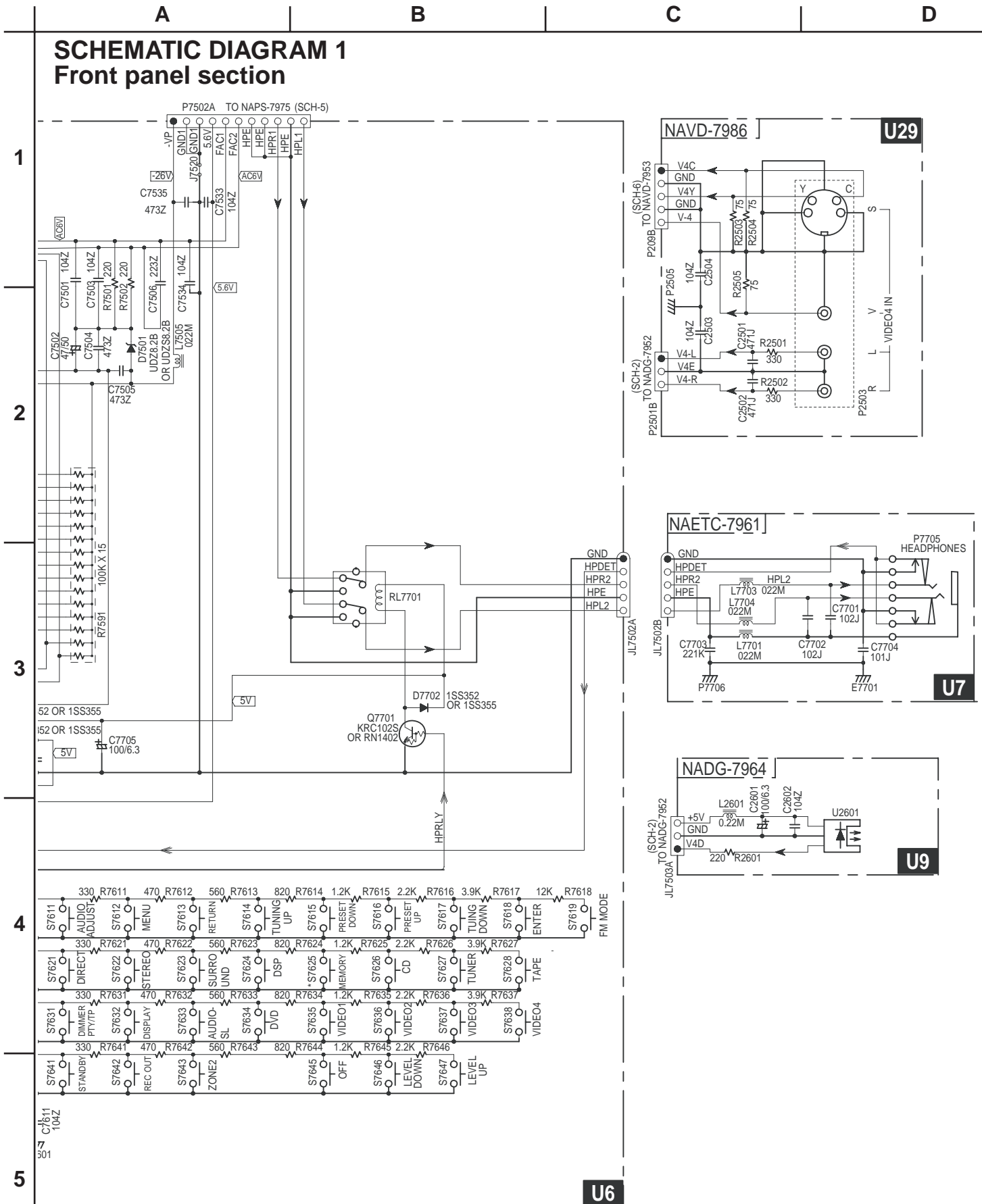

SCHEMATIC DIAGRAM 3 Driver section

NAAF-7984

TO NADG-7952

1

2

3

4

5

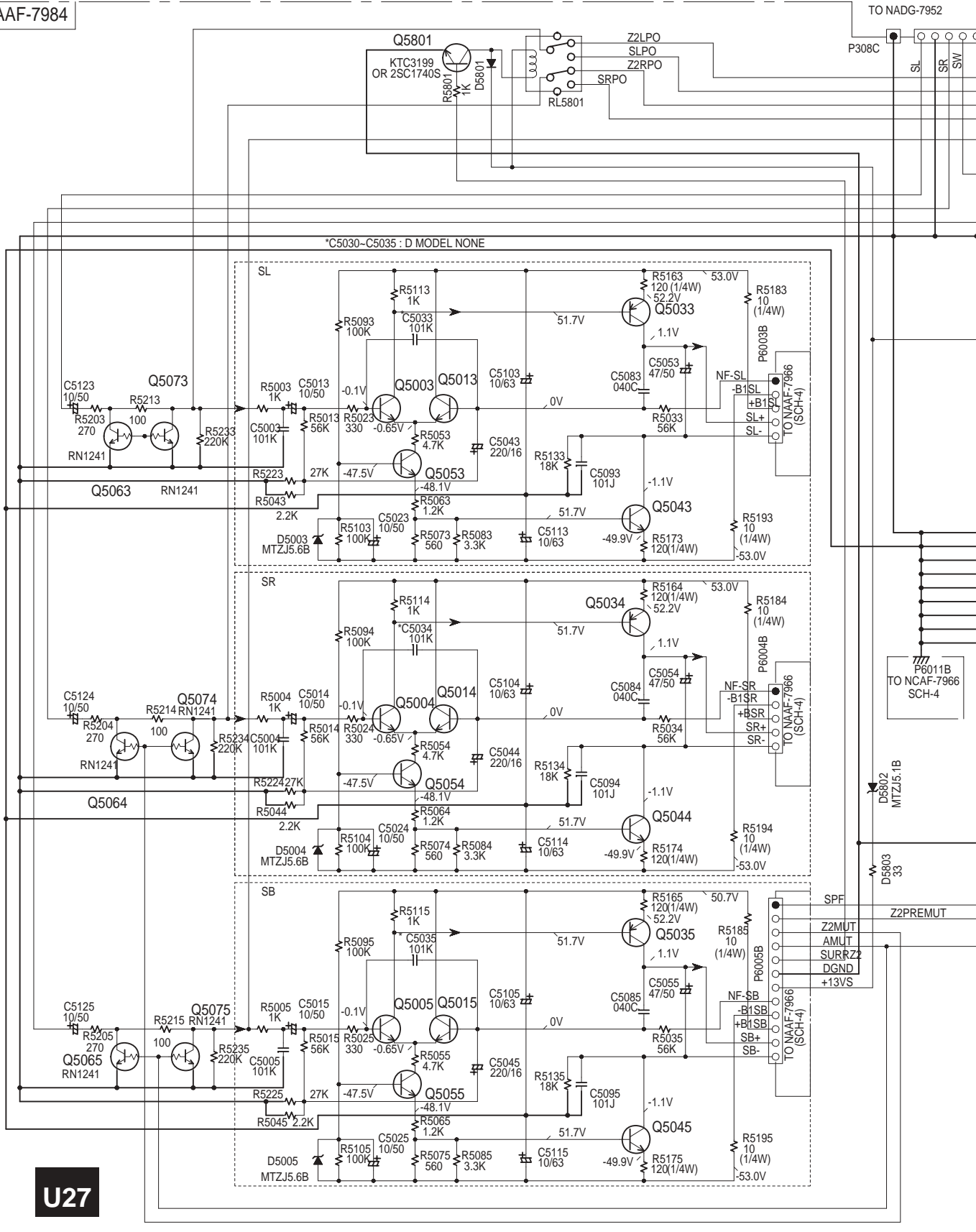

U27

NO.	L / R / C	SL / SR / SB
Q5000-04.5010-14	2SC1775A-E,F OR 2SC1845-E	KTC3200-BL OR 2SC1775A-E,F OR 2SC1845-E,F
Q5020-25	2SA992-E,F	
Q5030-35	2SA1360-Y,O	KTA1024-Y,O OR 2SA949-Y,O
Q5040-45	2SC3423-Y,O	KTC3206-Y,O OR 2SC2229-Y,O

SEMICONDUCTORS

SCHEMATIC DIAGRAM 3 Driver section

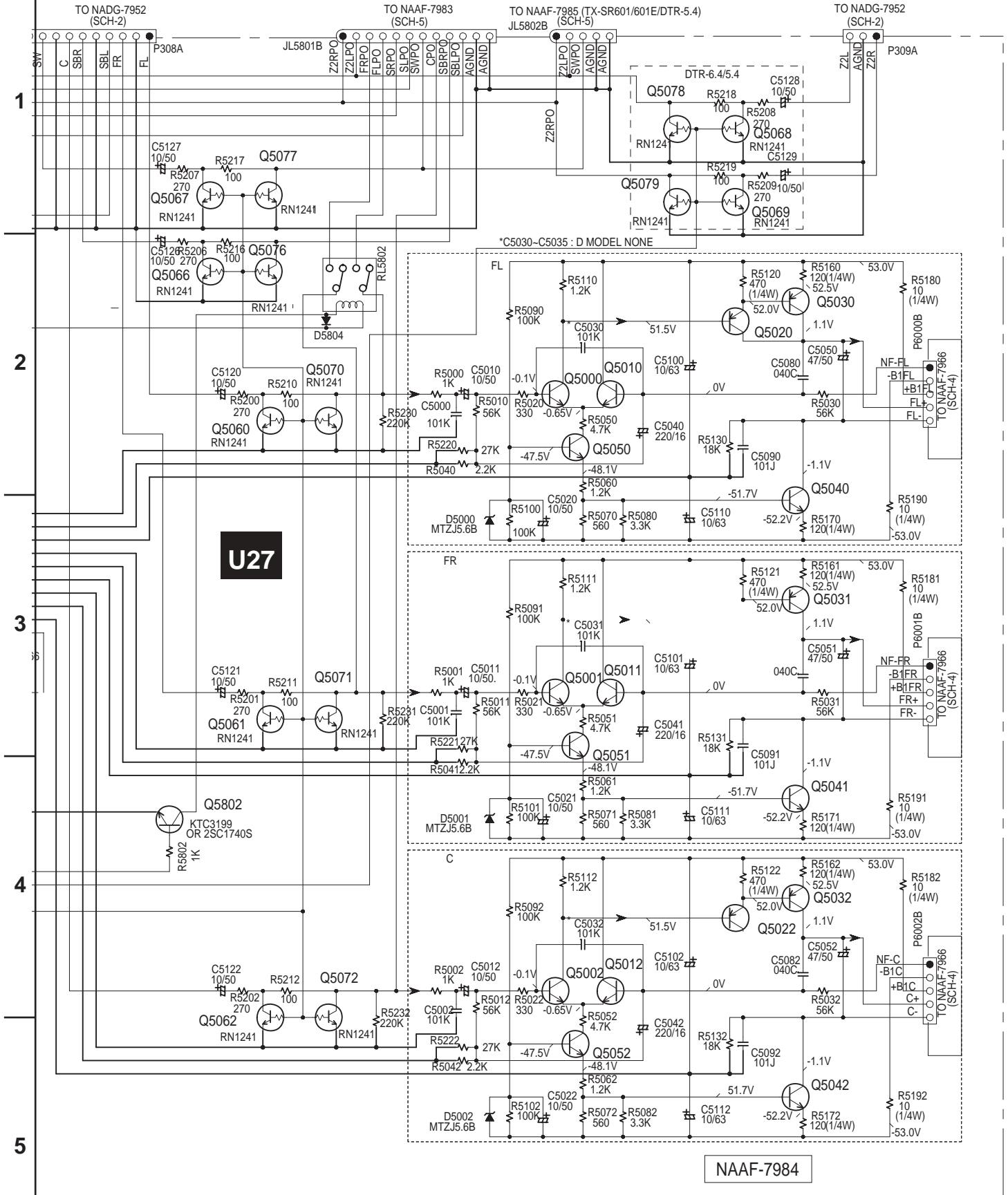

NAAF-7984

NO.	L/R/C	SL/SR/SB
Q5000-04.5010-14	2SC1775A-E,F OR 2SC1845-E	KTC3200-BL OR 2SC1775A-E,F OR 2SC1845-E,F
Q5020-25	2SA992-E,F	
Q5030-35	2SA1360-Y,O	KTA1024-Y,O OR 2SA949-Y,O
Q5040-45	2SC3423-Y,O	KTC3206-Y,O OR 2SC2229-Y,O

SEMICONDUCTORS

SCHEMATIC DIAGRAM 2 DSP and main microprocessor

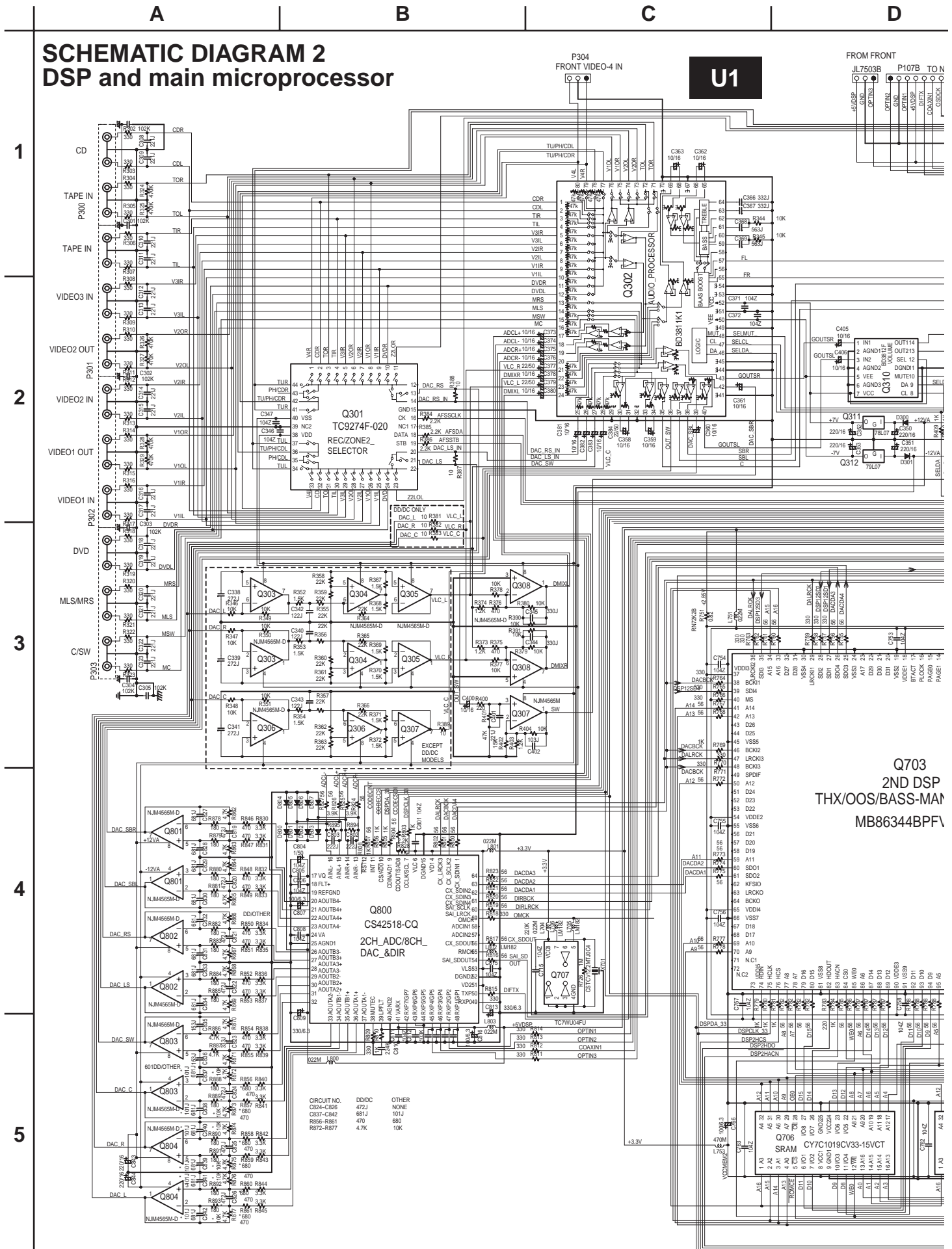

Q703
2ND DSP
THX/OOS/BASS-MAN
MB86344BPFV

CIRCUIT NO.	DDDC	OTHER
C824-C826	472J	NONE
C837-C842	681J	101J
R856-R861	470	680
R872-R877	4.7K	10K

Q706	SRAM	CY7C1019CV33-15VCT
1 A3	1 A3	1 A3
2 A2	2 A2	2 A2
3 A1	3 A1	3 A1
4 A0	4 A0	4 A0
5 A7	5 A7	5 A7
6 A6	6 A6	6 A6
7 A5	7 A5	7 A5
8 A4	8 A4	8 A4
9 A3	9 A3	9 A3
10 A2	10 A2	10 A2
11 A1	11 A1	11 A1
12 A0	12 A0	12 A0
13 OE	13 OE	13 OE
14 WE	14 WE	14 WE
15 A15	15 A15	15 A15
16 A14	16 A14	16 A14
17 A13	17 A13	17 A13
18 A12	18 A12	18 A12
19 A11	19 A11	19 A11
20 A10	20 A10	20 A10
21 A9	21 A9	21 A9
22 A8	22 A8	22 A8
23 A7	23 A7	23 A7
24 A6	24 A6	24 A6
25 A5	25 A5	25 A5
26 A4	26 A4	26 A4
27 A3	27 A3	27 A3
28 A2	28 A2	28 A2
29 A1	29 A1	29 A1
30 A0	30 A0	30 A0
31 VCC	31 VCC	31 VCC
32 GND	32 GND	32 GND
33 VCC	33 VCC	33 VCC
34 GND	34 GND	34 GND
35 VCC	35 VCC	35 VCC
36 GND	36 GND	36 GND
37 VCC	37 VCC	37 VCC
38 GND	38 GND	38 GND
39 VCC	39 VCC	39 VCC
40 GND	40 GND	40 GND
41 VCC	41 VCC	41 VCC
42 GND	42 GND	42 GND
43 VCC	43 VCC	43 VCC
44 GND	44 GND	44 GND
45 VCC	45 VCC	45 VCC
46 GND	46 GND	46 GND
47 VCC	47 VCC	47 VCC
48 GND	48 GND	48 GND
49 VCC	49 VCC	49 VCC
50 GND	50 GND	50 GND
51 VCC	51 VCC	51 VCC
52 GND	52 GND	52 GND
53 VCC	53 VCC	53 VCC
54 GND	54 GND	54 GND
55 VCC	55 VCC	55 VCC
56 GND	56 GND	56 GND
57 VCC	57 VCC	57 VCC
58 GND	58 GND	58 GND
59 VCC	59 VCC	59 VCC
60 GND	60 GND	60 GND
61 VCC	61 VCC	61 VCC
62 GND	62 GND	62 GND
63 VCC	63 VCC	63 VCC
64 GND	64 GND	64 GND
65 VCC	65 VCC	65 VCC
66 GND	66 GND	66 GND
67 VCC	67 VCC	67 VCC
68 GND	68 GND	68 GND
69 VCC	69 VCC	69 VCC
70 GND	70 GND	70 GND
71 VCC	71 VCC	71 VCC
72 GND	72 GND	72 GND
73 VCC	73 VCC	73 VCC
74 GND	74 GND	74 GND
75 VCC	75 VCC	75 VCC
76 GND	76 GND	76 GND
77 VCC	77 VCC	77 VCC
78 GND	78 GND	78 GND
79 VCC	79 VCC	79 VCC
80 GND	80 GND	80 GND
81 VCC	81 VCC	81 VCC
82 GND	82 GND	82 GND
83 VCC	83 VCC	83 VCC
84 GND	84 GND	84 GND
85 VCC	85 VCC	85 VCC
86 GND	86 GND	86 GND
87 VCC	87 VCC	87 VCC
88 GND	88 GND	88 GND
89 VCC	89 VCC	89 VCC
90 GND	90 GND	90 GND
91 VCC	91 VCC	91 VCC
92 GND	92 GND	92 GND
93 VCC	93 VCC	93 VCC
94 GND	94 GND	94 GND
95 VCC	95 VCC	95 VCC
96 GND	96 GND	96 GND
97 VCC	97 VCC	97 VCC
98 GND	98 GND	98 GND
99 VCC	99 VCC	99 VCC
100 GND	100 GND	100 GND

SCHEMATIC DIAGRAM 2

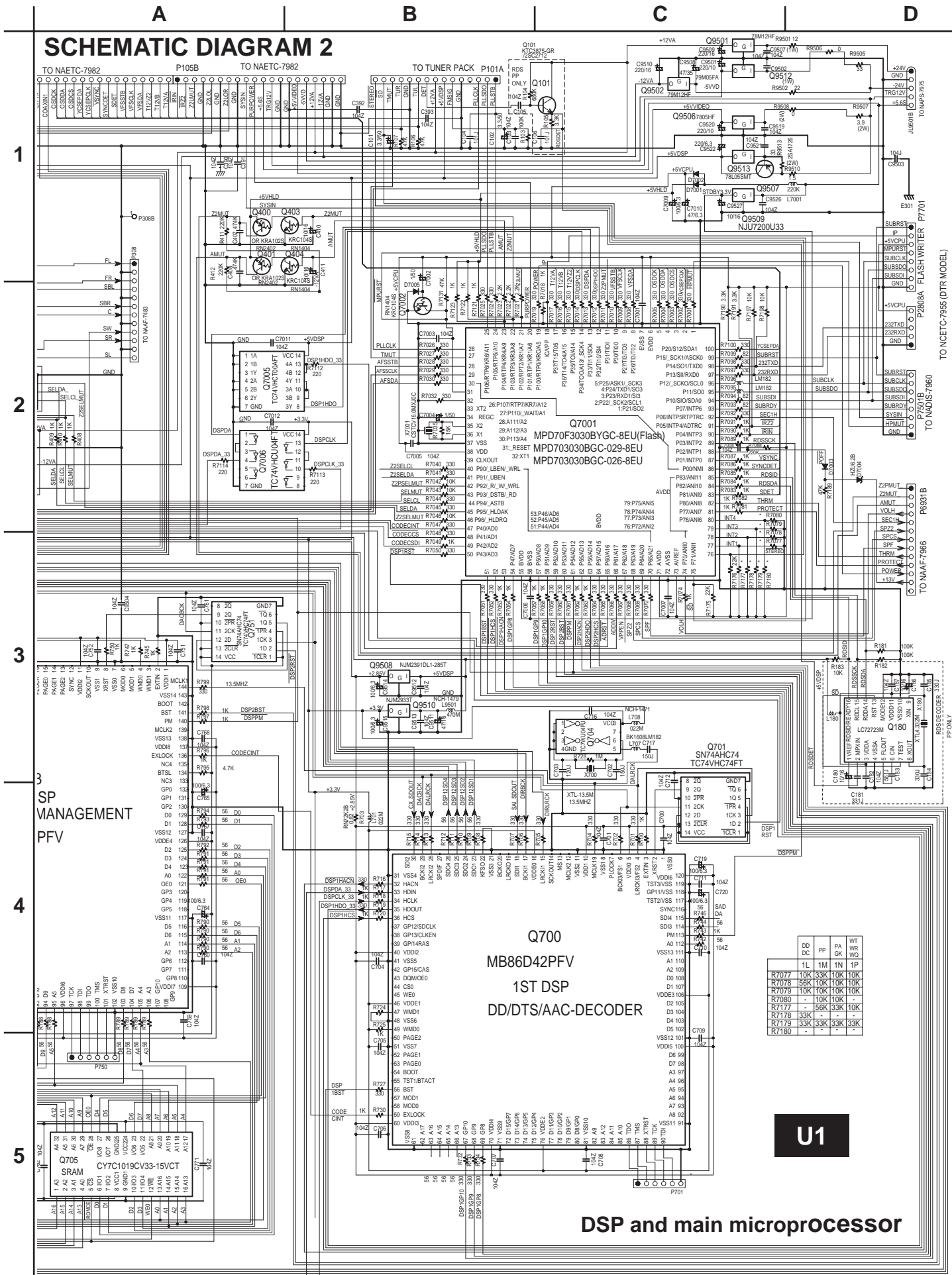

DO	DC	PP	PA	PK	WR	1P
R7077	10K	13K	10K	10K	10K	10K
R7078	56K	10K	10K	10K	10K	10K
R7079	10K	10K	10K	10K	10K	10K
R7080	10K	10K	10K	10K	10K	10K
R7177	56K	33K	33K	33K	33K	33K
R7178	33K	33K	33K	33K	33K	33K
R7179	33K	33K	33K	33K	33K	33K
R7180	10K	10K	10K	10K	10K	10K

U1

DSP and main microprocessor

A

B

C

D

SCHEMATIC DIAGRAM 1-1
Front panel section

1

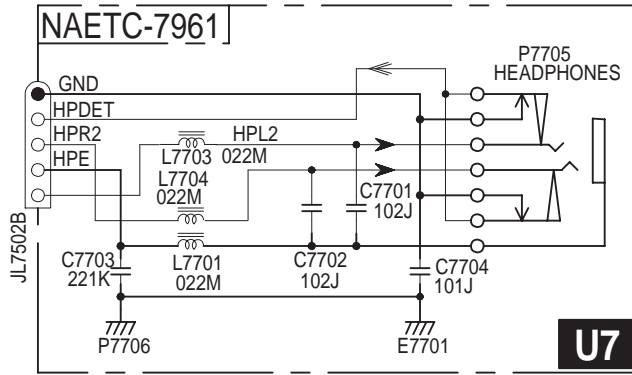

2

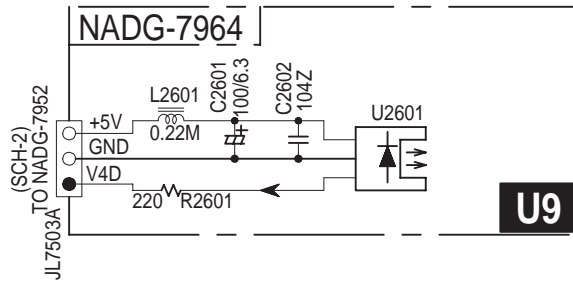

3

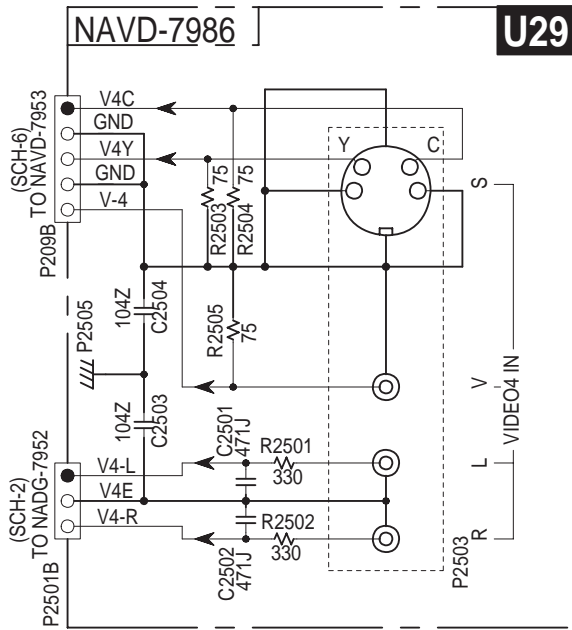

4

5

A B C D
SCHEMATIC DIAGRAM 4 Power amplifier section

NAAF-7966

1

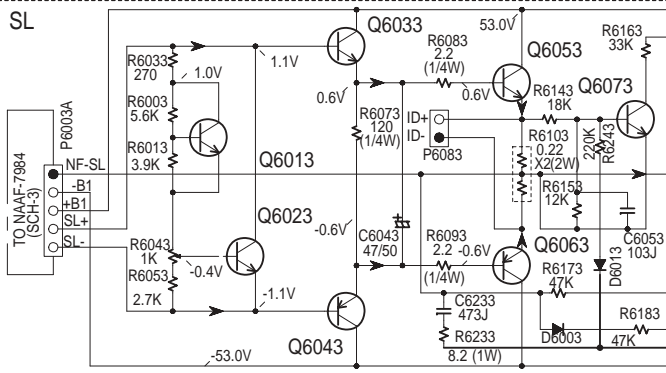

2

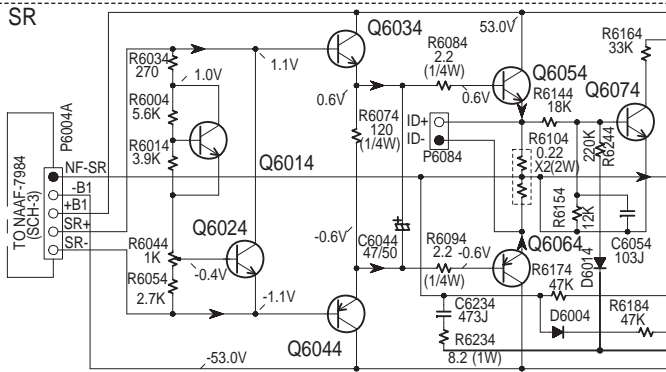

3

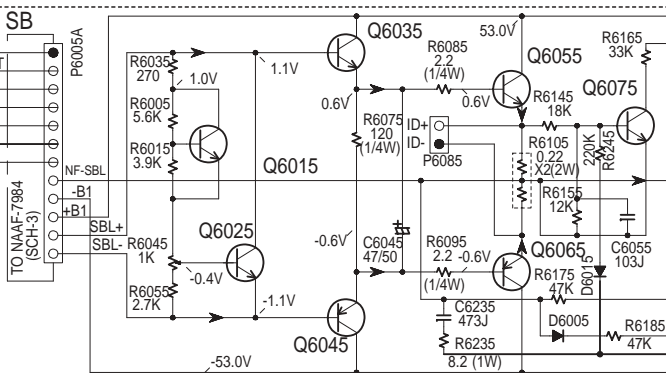

4

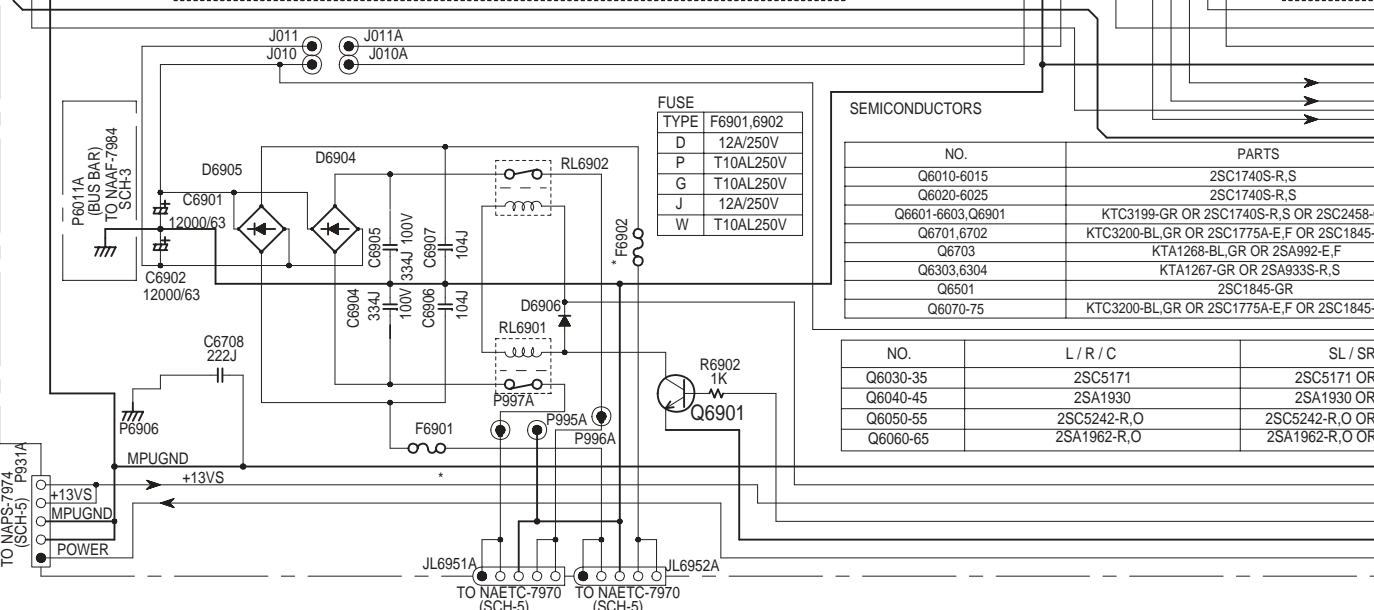

5

FUSE

TYPE	F6901,6902
D	12A/250V
P	T10AL250V
G	T10AL250V
J	12A/250V
W	T10AL250V

SEMICONDUCTORS

NO.	PARTS
Q6010-6015	2SC1740S-R,S
Q6020-6025	2SC1740S-R,S
Q6601-6603,Q6901	KTC3199-GR OR 2SC1740S-R,S OR 2SC2458-C
Q6701,6702	KTC3200-BL,GR OR 2SC1775A-E,F OR 2SC1845-
Q6703	KTA1268-BL,GR OR 2SA992-E,F
Q6303,6304	KTA1267-GR OR 2SA933S-R,S
Q6501	2SC1845-GR
Q6070-75	KTC3200-BL,GR OR 2SC1775A-E,F OR 2SC1845-

NO.	L / R / C	SL / SR
Q6030-35	2SC5171	2SC5171 OR
Q6040-45	2SA1930	2SA1930 OR
Q6050-55	2SC5242-R,O	2SC5242-R,O OR
Q6060-65	2SA1962-R,O	2SA1962-R,O OR

SCHEMATIC DIAGRAM 4 Power amplifier section

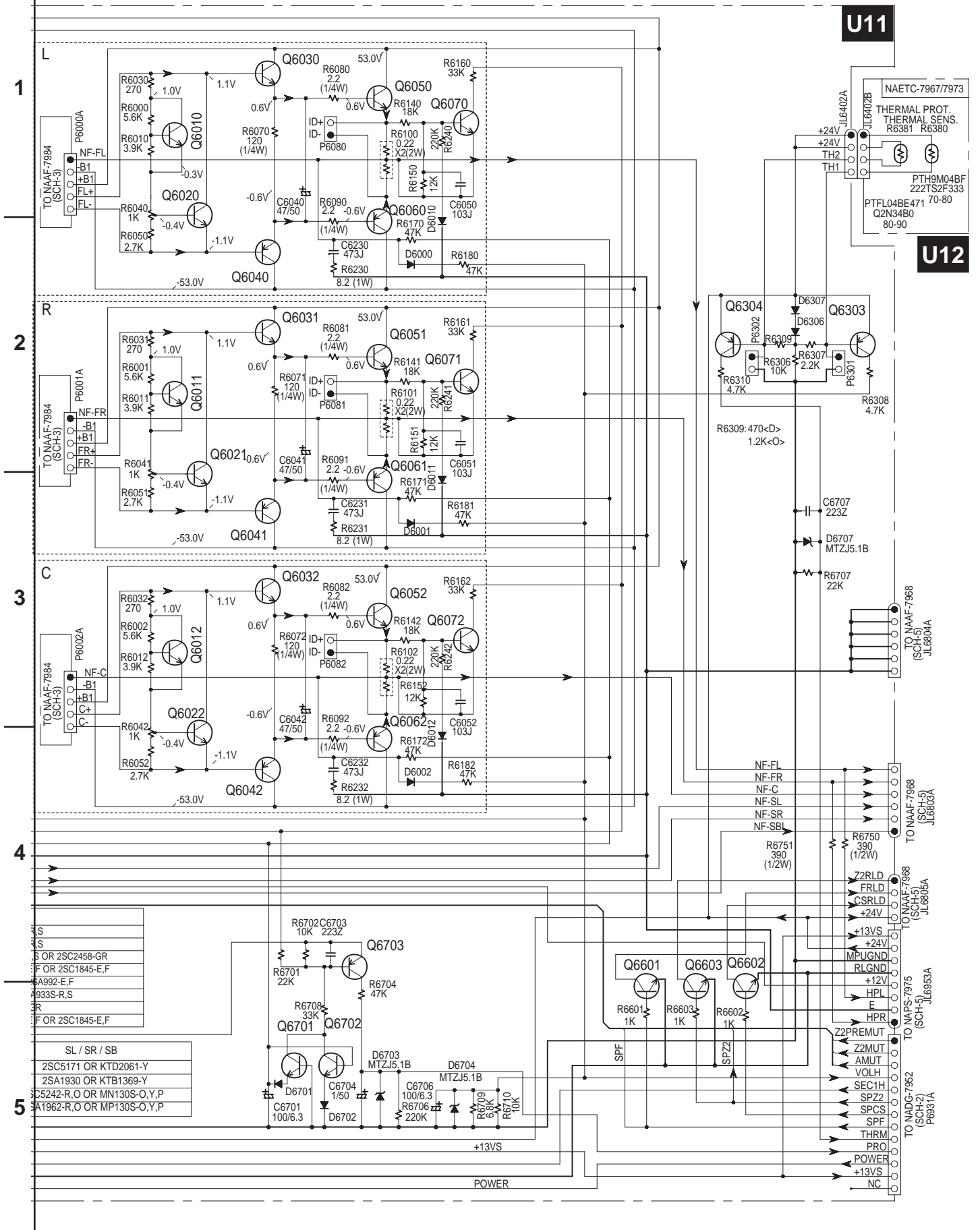

A **B** **C** **D**
SCHEMATIC DIAGRAM 5 Power supply and speaker terminal sections

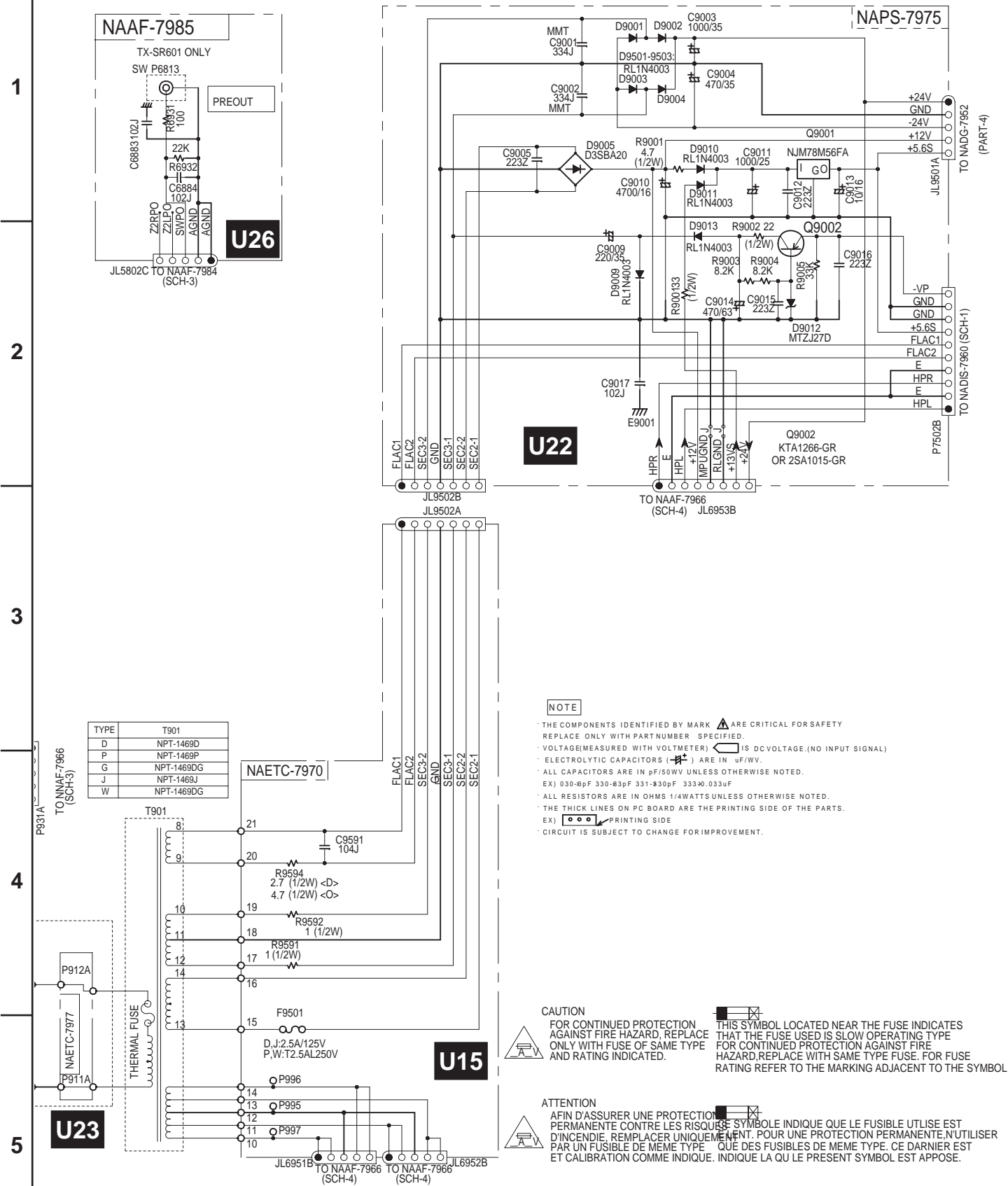

NOTE

- THE COMPONENTS IDENTIFIED BY MARK ARE CRITICAL FOR SAFETY. REPLACE ONLY WITH PART NUMBER SPECIFIED.
- VOLTAGE (MEASURED WITH VOLTMETER) IS DC VOLTAGE (NO INPUT SIGNAL).
- ELECTROLYTIC CAPACITORS () ARE IN μ F/WV.
- ALL CAPACITORS ARE IN pF/50V UNLESS OTHERWISE NOTED.
- EX) 030-8pF 330-83pF 331-830pF 333-80 033uF
- ALL RESISTORS ARE IN OHMS 1/4WATTS UNLESS OTHERWISE NOTED.
- THE THICK LINES ON PC BOARD ARE THE PRINTING SIDE OF THE PARTS.
- EX) PRINTING SIDE
- CIRCUIT IS SUBJECT TO CHANGE FOR IMPROVEMENT.

CAUTION

FOR CONTINUED PROTECTION AGAINST FIRE HAZARD, REPLACE ONLY WITH FUSE OF SAME TYPE AND RATING INDICATED.

THIS SYMBOL LOCATED NEAR THE FUSE INDICATES THAT THE FUSE USED IS SLOW OPERATING TYPE FOR CONTINUED PROTECTION AGAINST FIRE HAZARD. REPLACE WITH SAME TYPE FUSE. FOR FUSE RATING REFER TO THE MARKING ADJACENT TO THE SYMBOL.

ATTENTION

AFIN D'ASSURER UNE PROTECTION PERMANENTE CONTRE LES RISQUES D'INCENDIE, REMPLACER UNIQUEMENT PAR UN FUSIBLE DE MEME TYPE ET CALIBRATION COMME INDIQUE. INDIQUE LA QU LE PRESENT SYMBOLE EST APPOSE.

SYMBOLE INDIQUE QUE LE FUSIBLE UTILISE EST POUR UNE PROTECTION PERMANENTE, N'UTILISER QUE DES FUSIBLES DE MEME TYPE.

A B C D
SCHEMATIC DIAGRAM 5 Power supply and speaker terminal sections

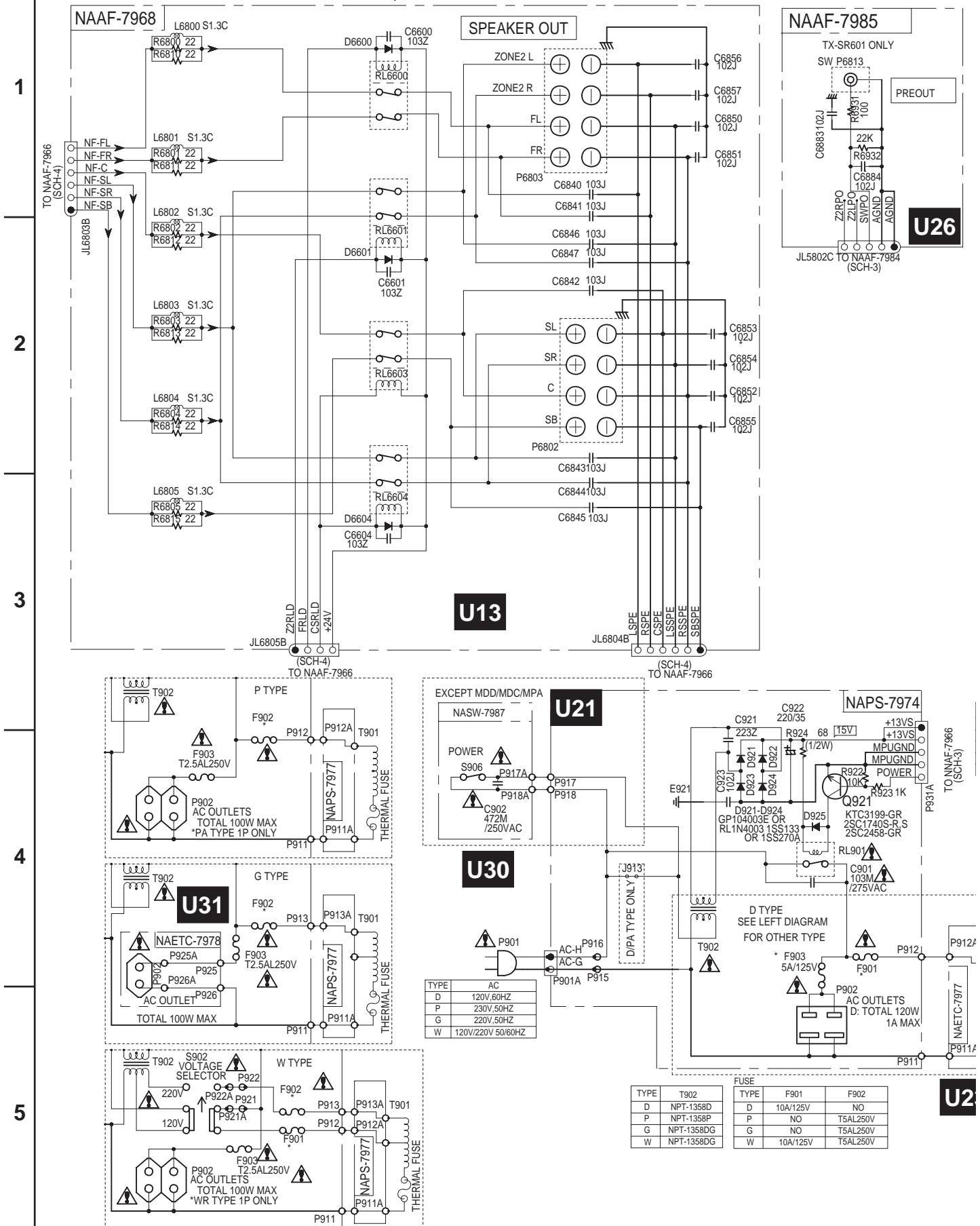

SCHEMATIC DIAGRAM 6 Video and bus line sections

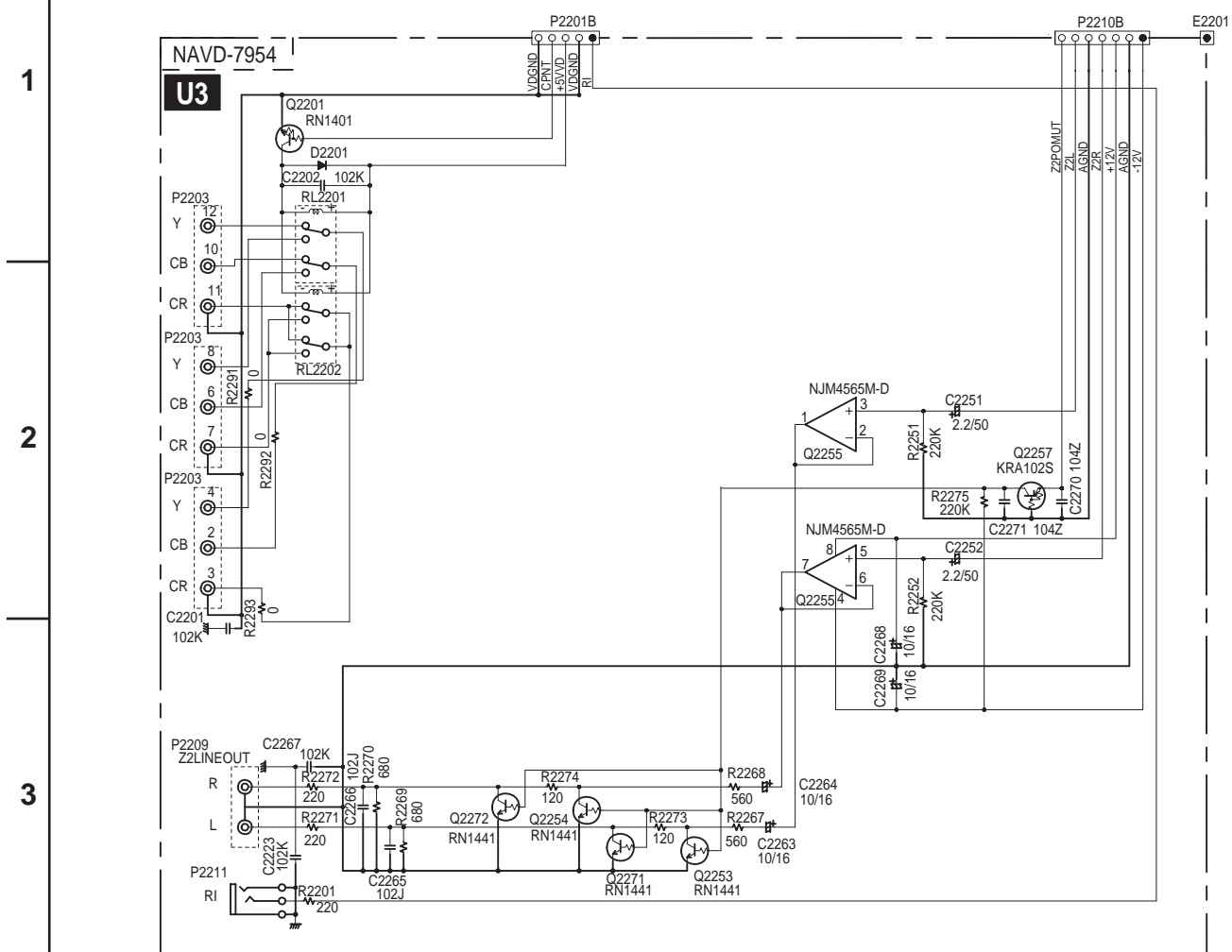

SCHEMATIC DIAGRAM 6 Video and bus line sections

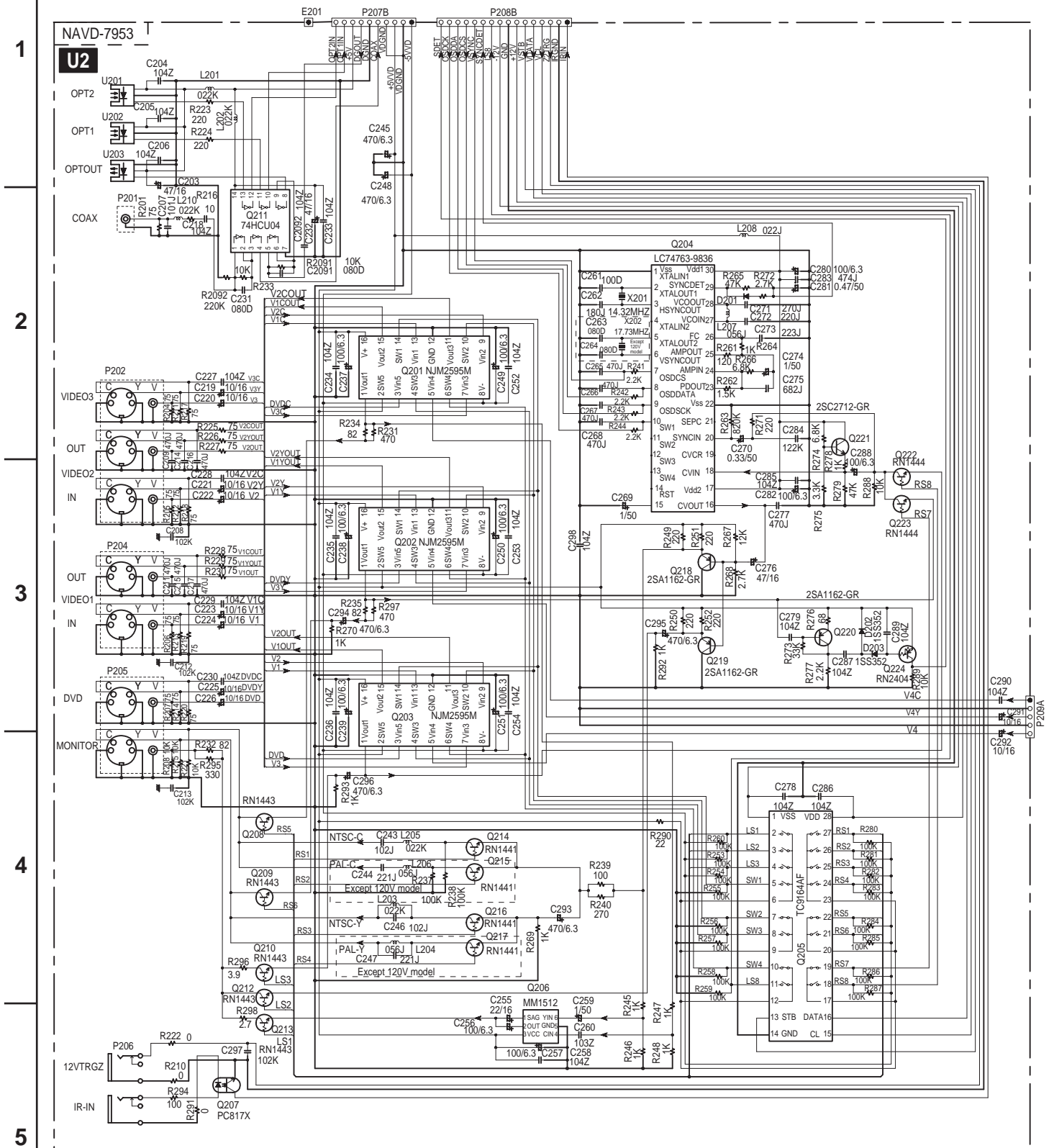

A B C D

PRINTED CIRCUIT BOARD VIEW 7

U25

1

2

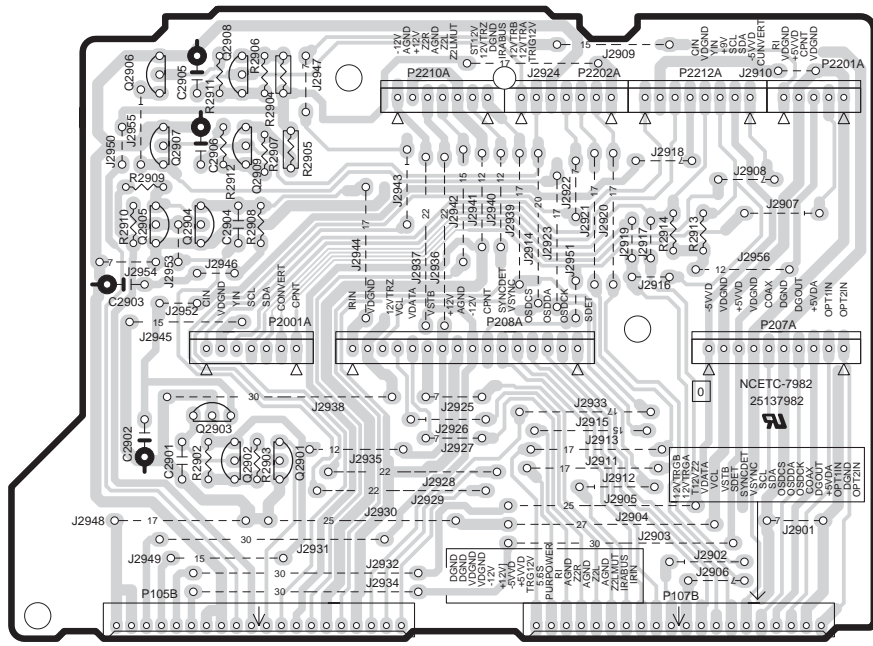

MAIN CONNECTOR PC BOARD (NAETC-7982)

3

4

5

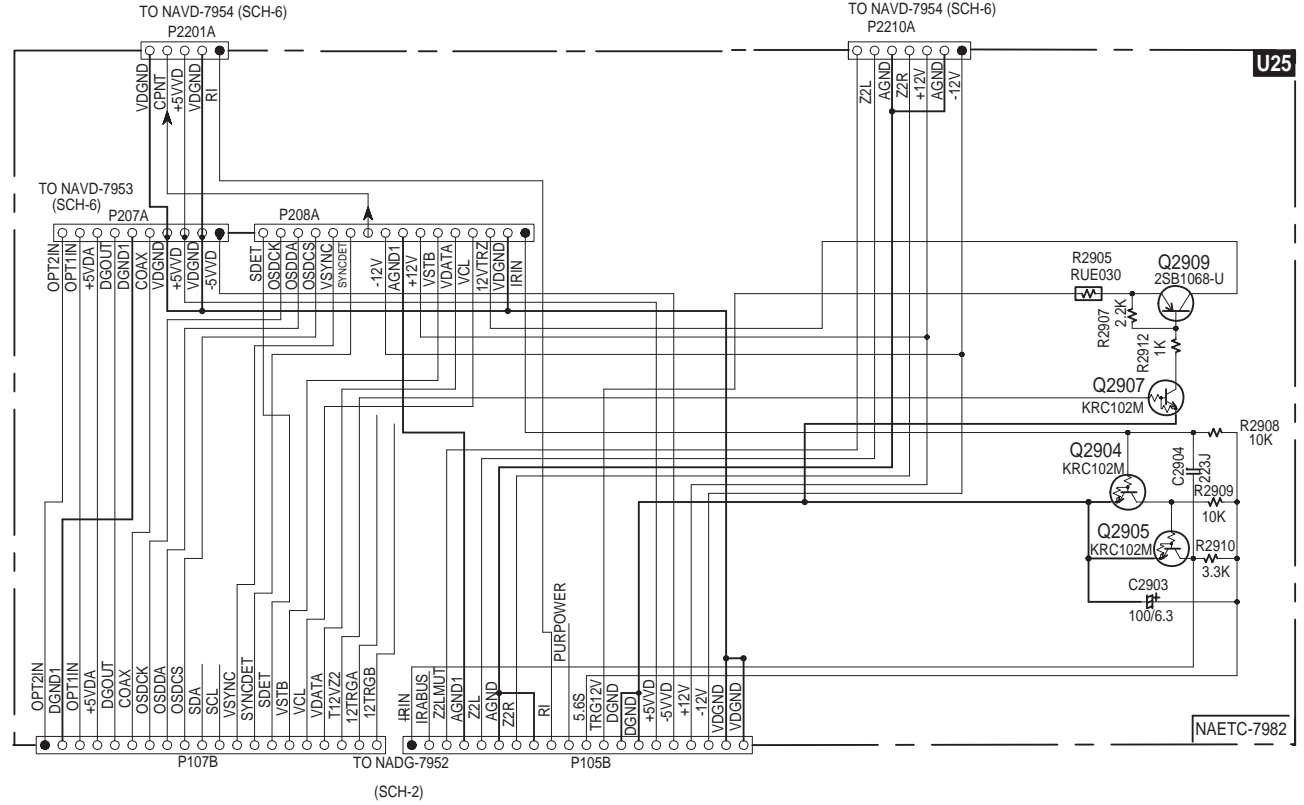

NAETC-7982

WIRING VIEW

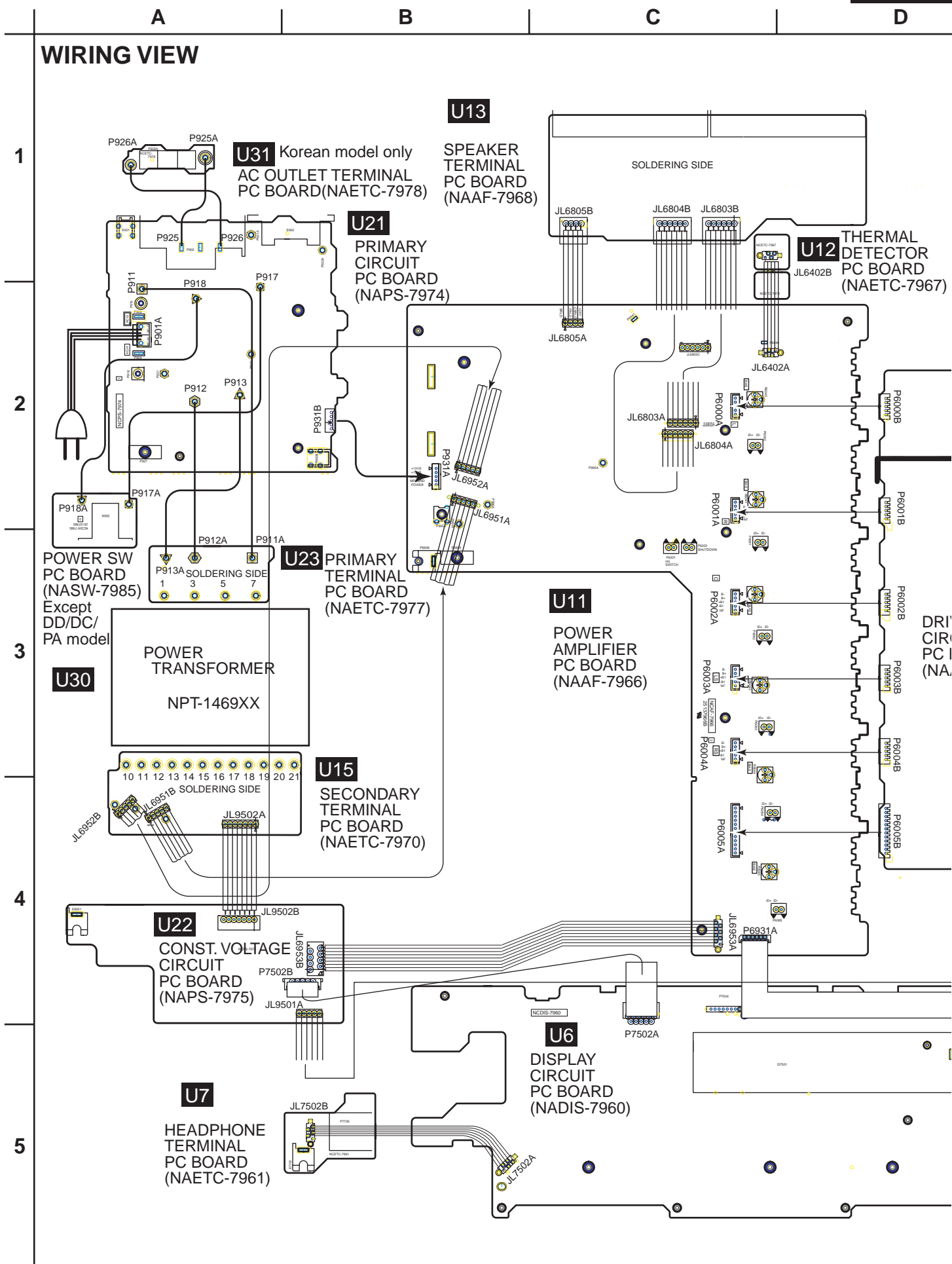

A B C D

WIRING VIEW

1

2

3

4

5

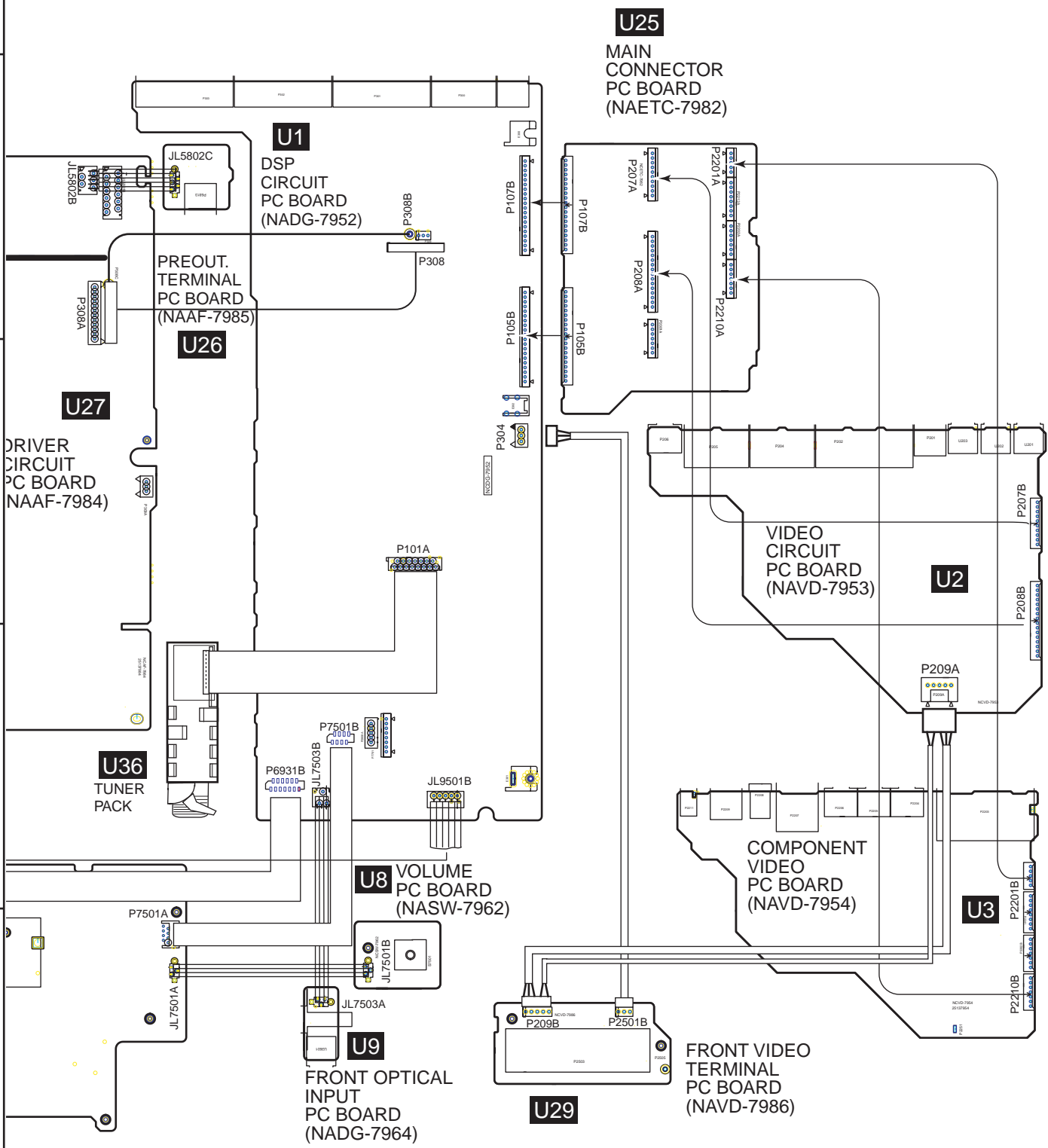

A

B

C

D

PRINTED CIRCUIT BOARD VIEW 1-2

Front panel section

1

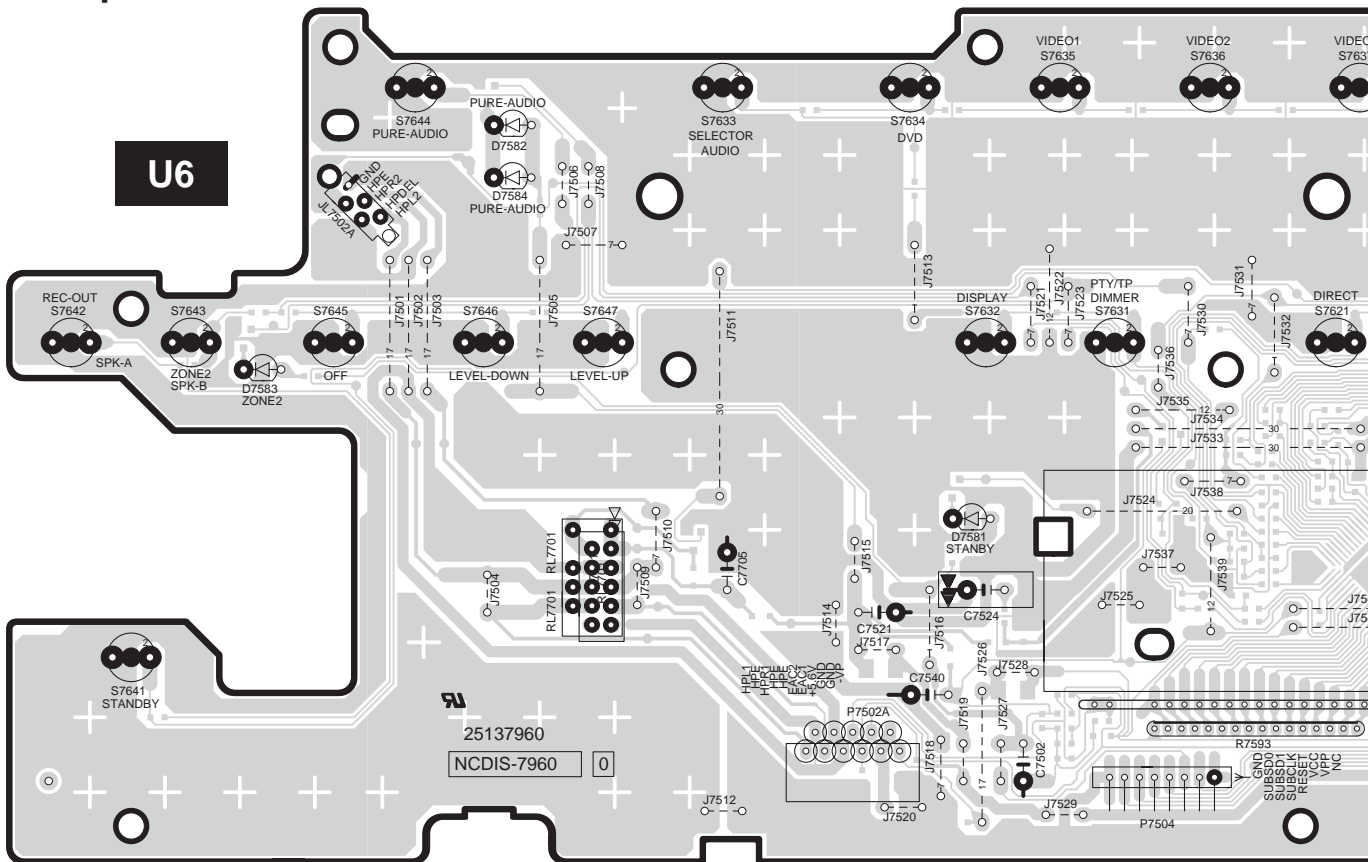

2

3

Component side

DISPLAY CIRCUIT PC BOARD

U6

4

Soldering side

DISPLAY CIRCUIT PC BOARD

5

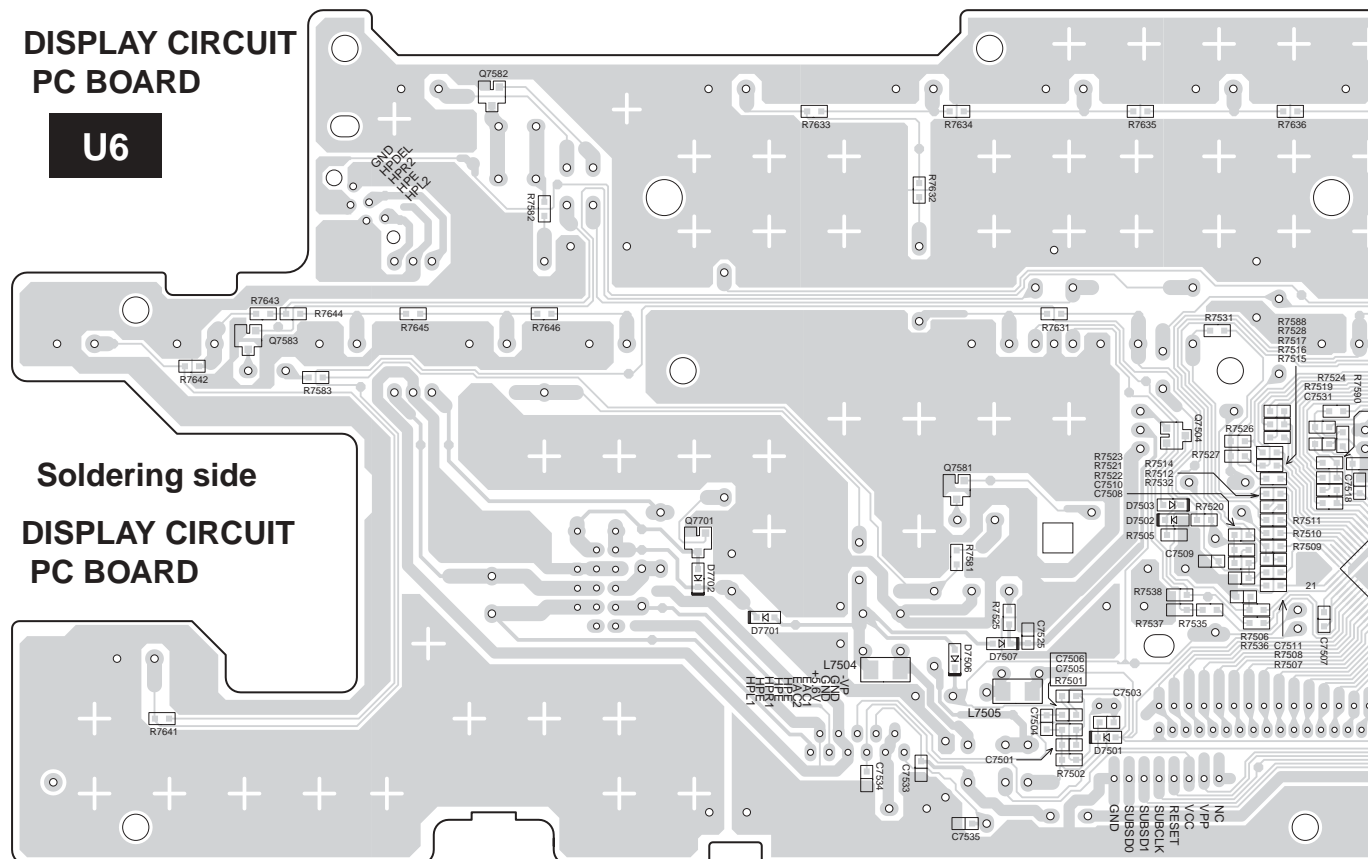

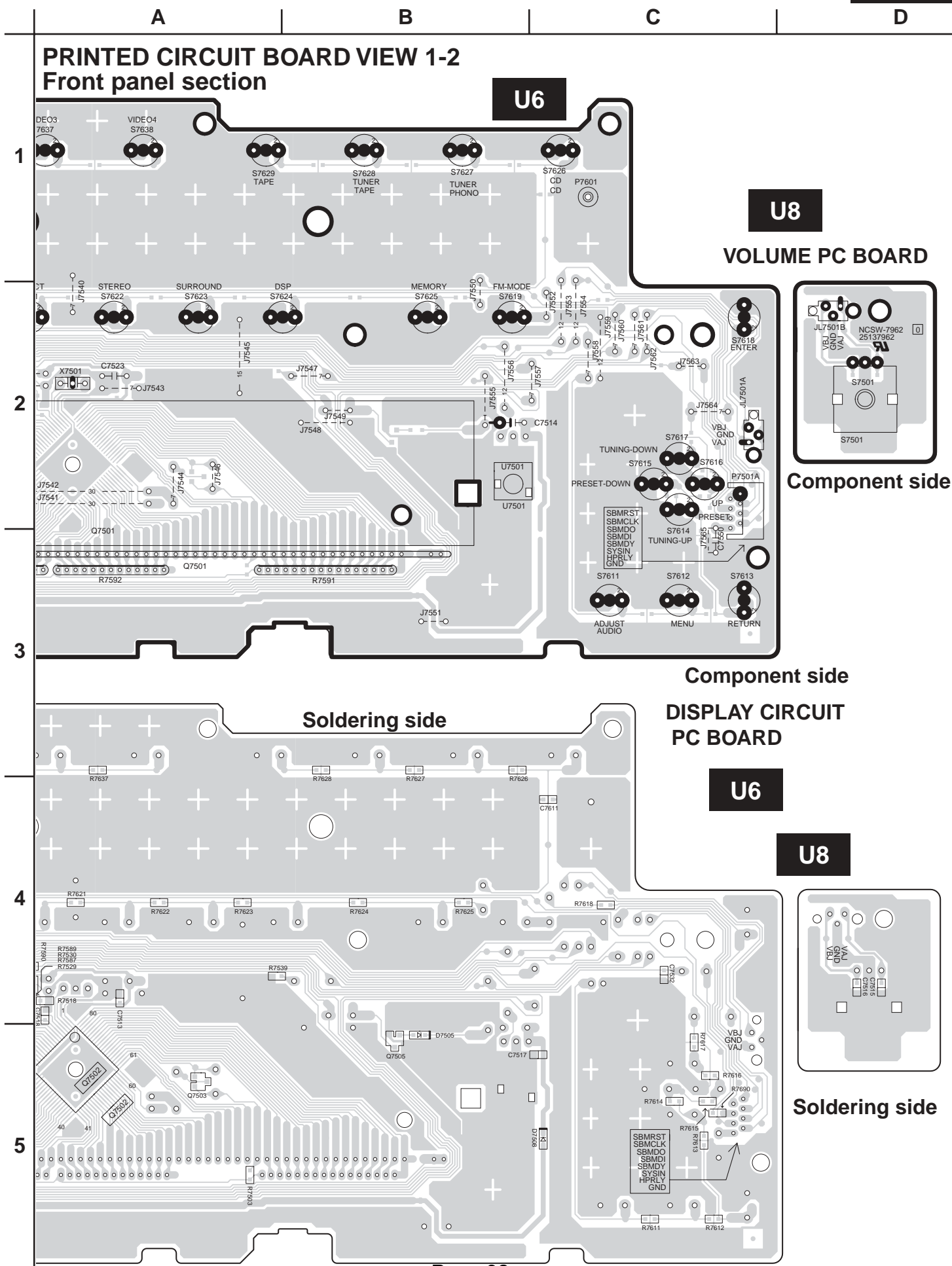

A B C D
PRINTED CIRCUIT BOARD VIEW 3
Power amplifier section section

1

2

3

4

5

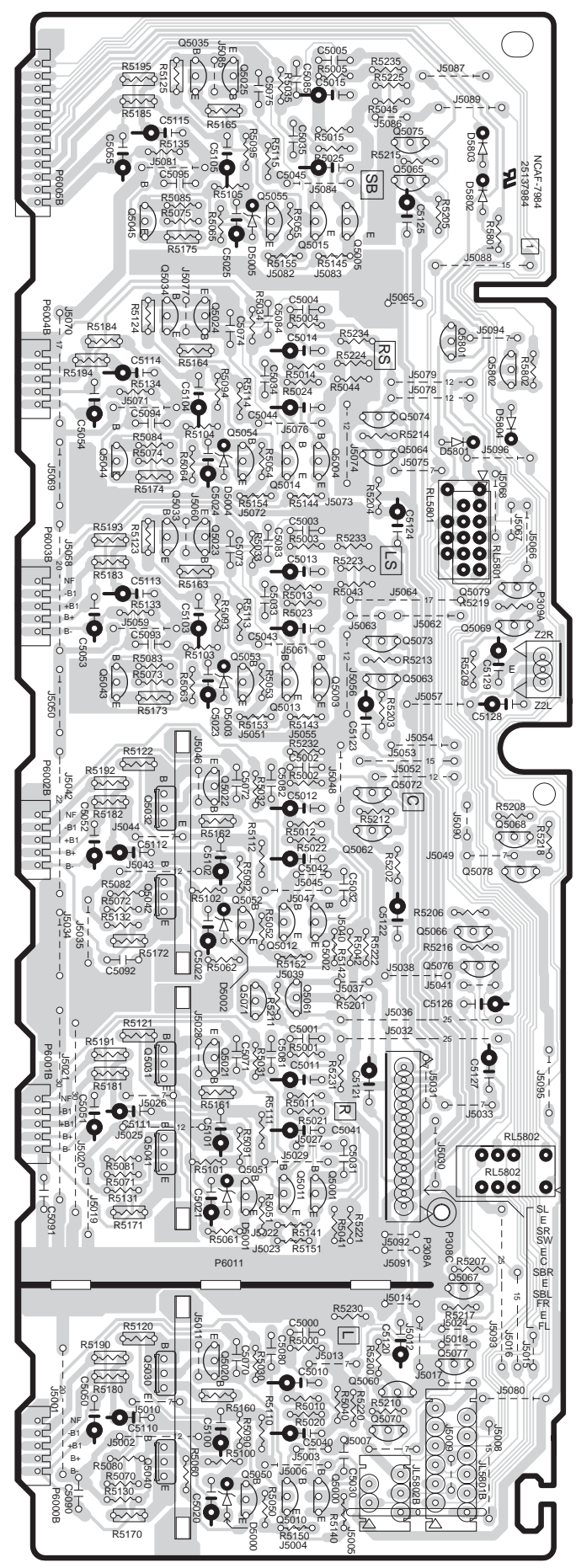

U27

DRIVER CIRCUIT PC BOARD
(NAAF-7984)

A

B

C

D

PRINTED CIRCUIT BOARD VIEW 2
DSP and main microprocessor

1

U1

2

3

4

5

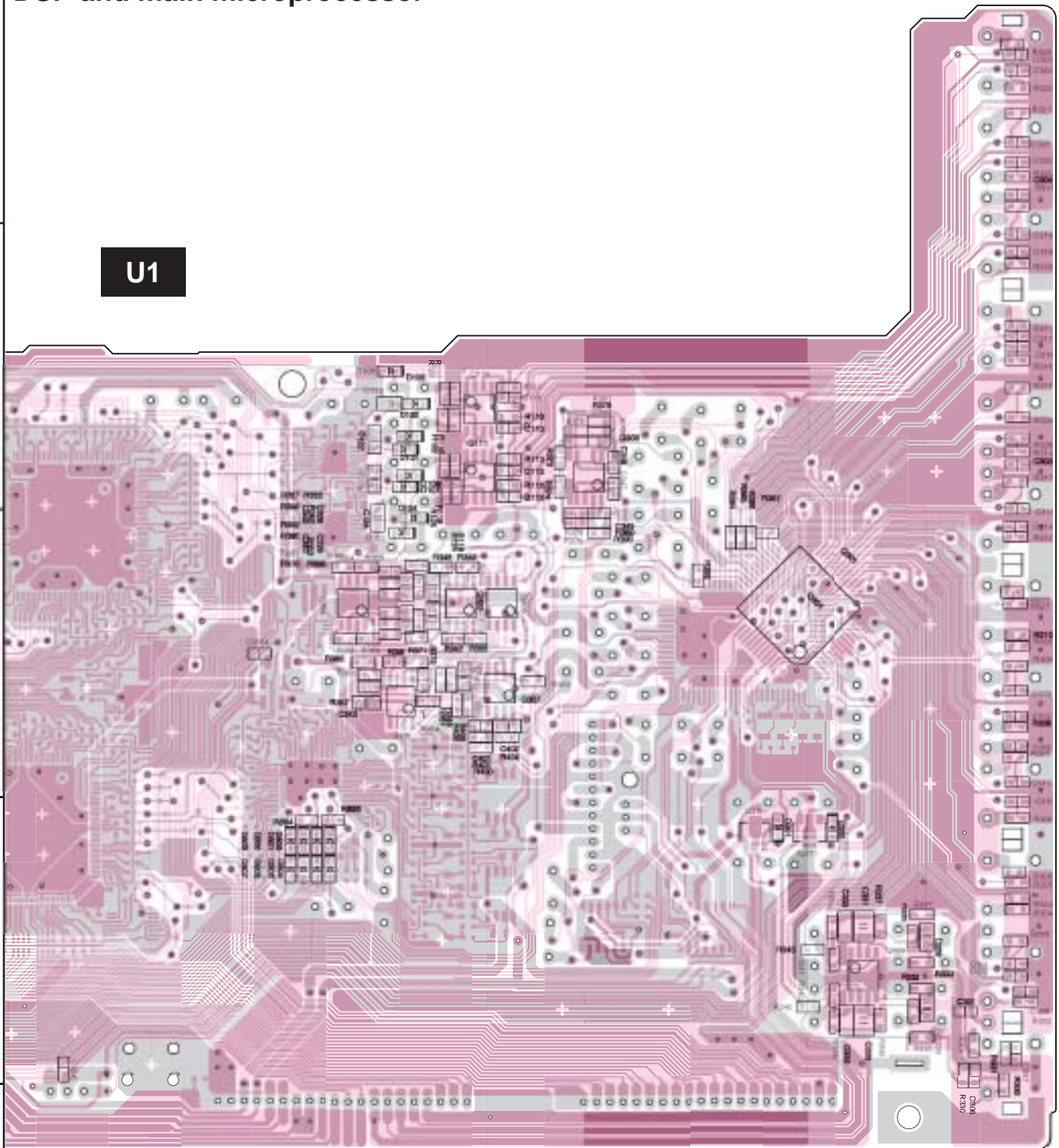

DSP CIRCUIT PC BOARD(NADG-7952)

A

B

C

D

PRINTED CIRCUIT BOARD VIEW 2
DSP and main microprocessor

1

U1

2

3

4

5

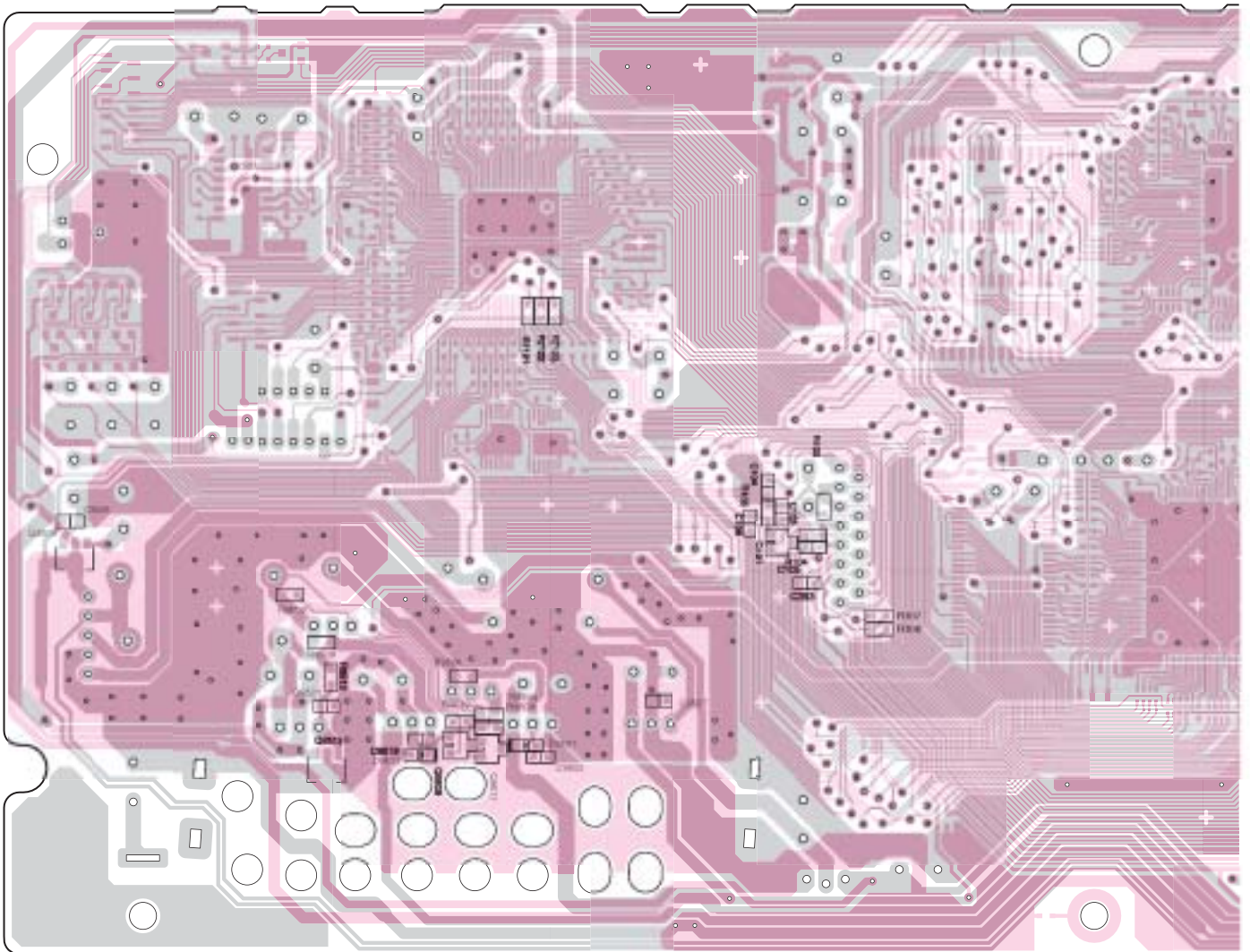

DSP CIRCUIT PC BOARD(NADG-7952)

A

B

C

D

PRINTED CIRCUIT BOARD VIEW 2 DSP and main microprocessor

1

2

U1

3

4

5

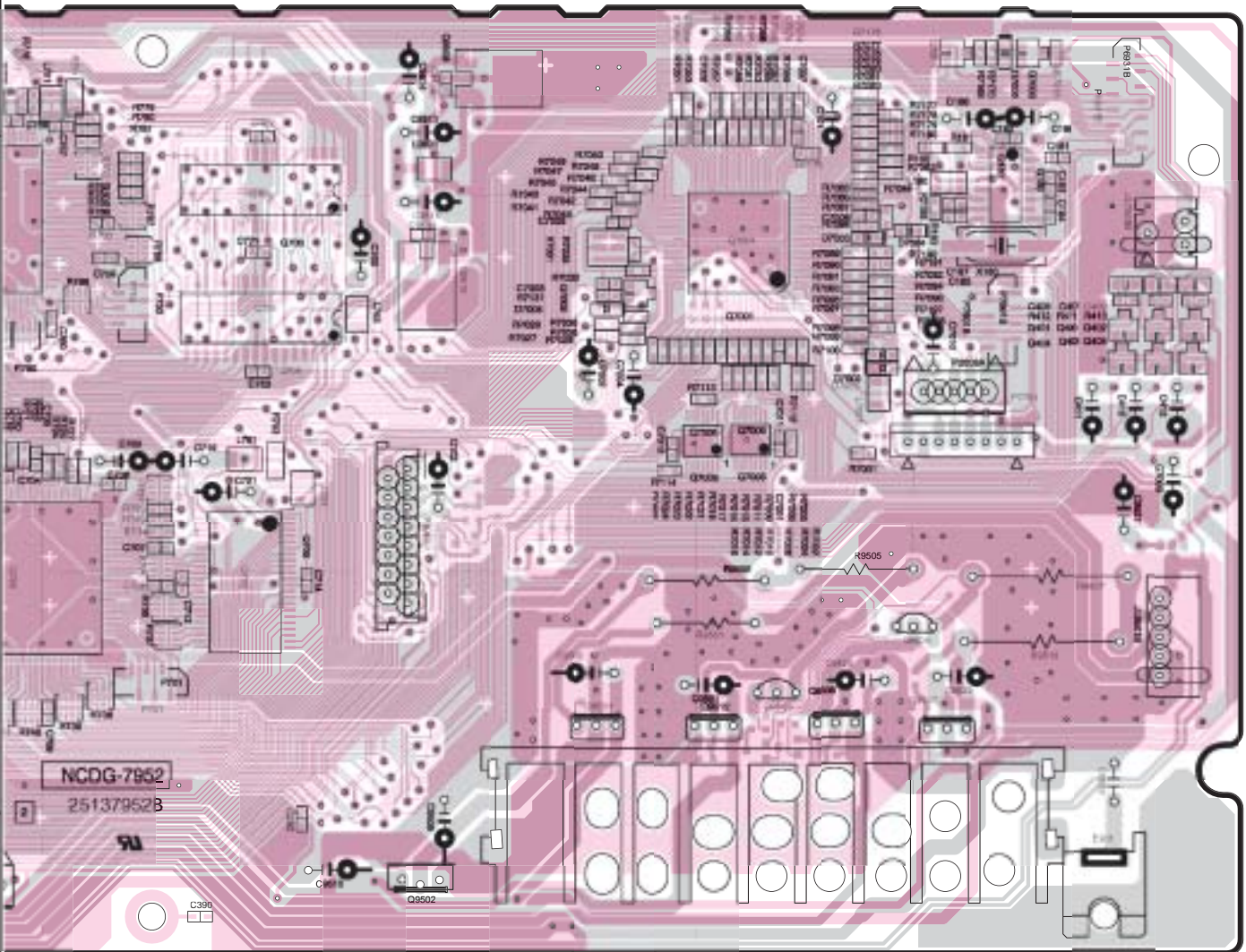

DSP CIRCUIT PC BOARD(NADG-7952)

A

B

C

D

PRINTED CIRCUIT BOARD VIEW 2 DSP and main microprocessor

1

2

3

4

5

U1



DSP CIRCUIT PC BOARD(NADG-7952)

A

B

C

D

PRINTED CIRCUIT BOARD VIEW 1-1

1

U7

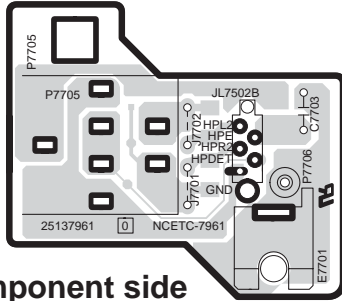

Component side

HEADPHONE TERMINAL PC BOARD(NAETC-7961)

2

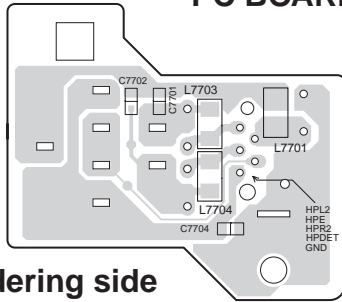

Soldering side

HEADPHONE TERMINAL PC BOARD(NAETC-7961)

3

U29

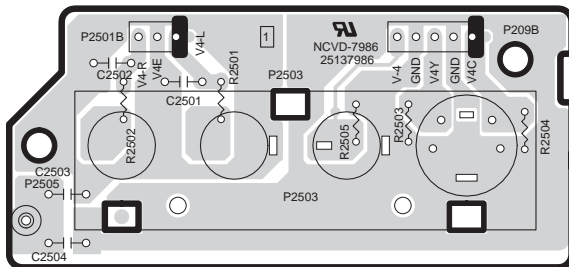

FRONT VIDEO TERMINAL PC BOARD (NAVD-7986)

5

U9

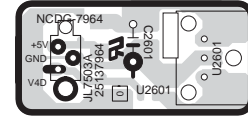

Component side

FRONT OPTICAL INPUT PC BOARD (NADG-7964)

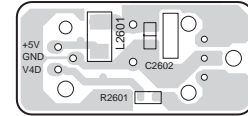

Soldering side

FRONT OPTICAL INPUT PC BOARD (NADG-7964)

A

B

C

D

PRINTED CIRCUIT BOARD VIEW 3 Power amplifier section section

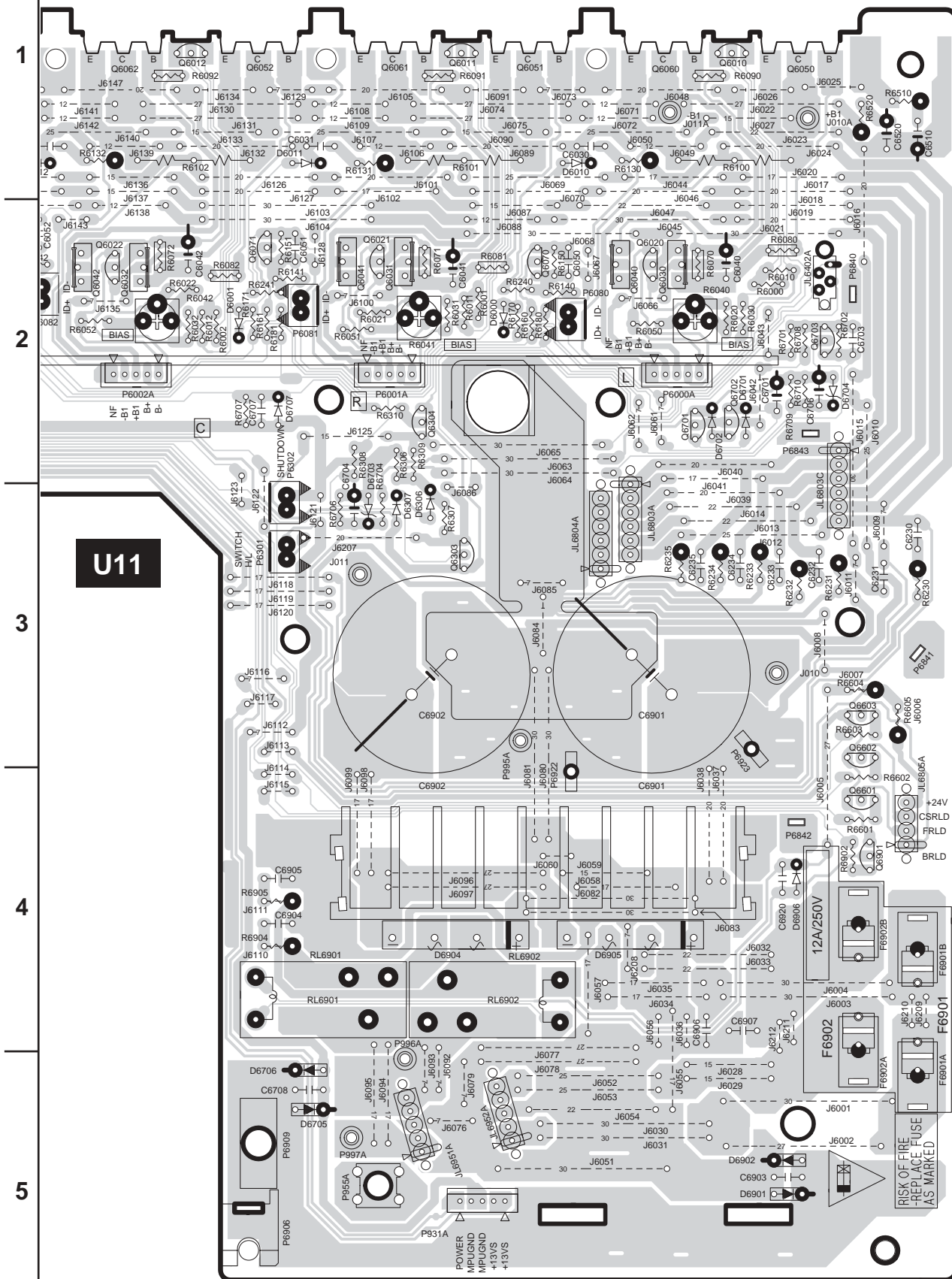

POWER AMPLIFIER PC BOARD (NAAF-7966)

A

B

C

D

PRINTED CIRCUIT BOARD VIEW 3 Power amplifier section section

1

2

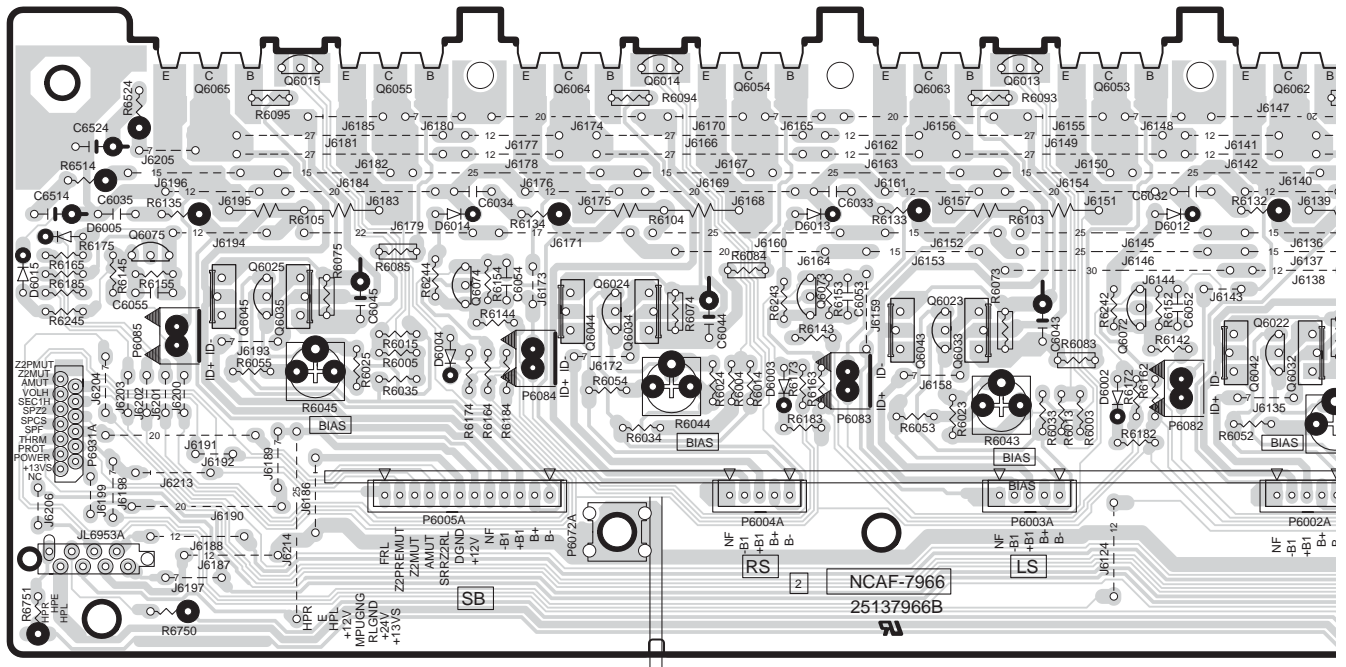

U11

**POWER AMPLIFIER PC BOARD
(NAAF-7966)**

3

U12

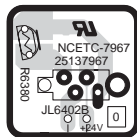

**THERMAL DETECTOR PC BOARD
(NAETC-7967)**

4

5

A B C D

PRINTED CIRCUIT BOARD VIEW 5

U13

1
2

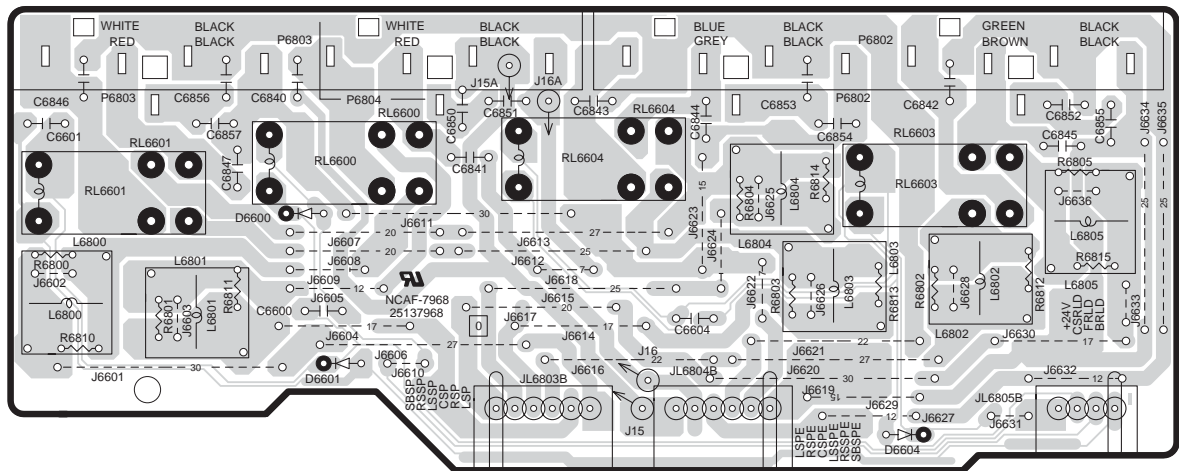

SPEAKER TERMINAL PC BOARD (NAAF-7968)

U21

3
4
5

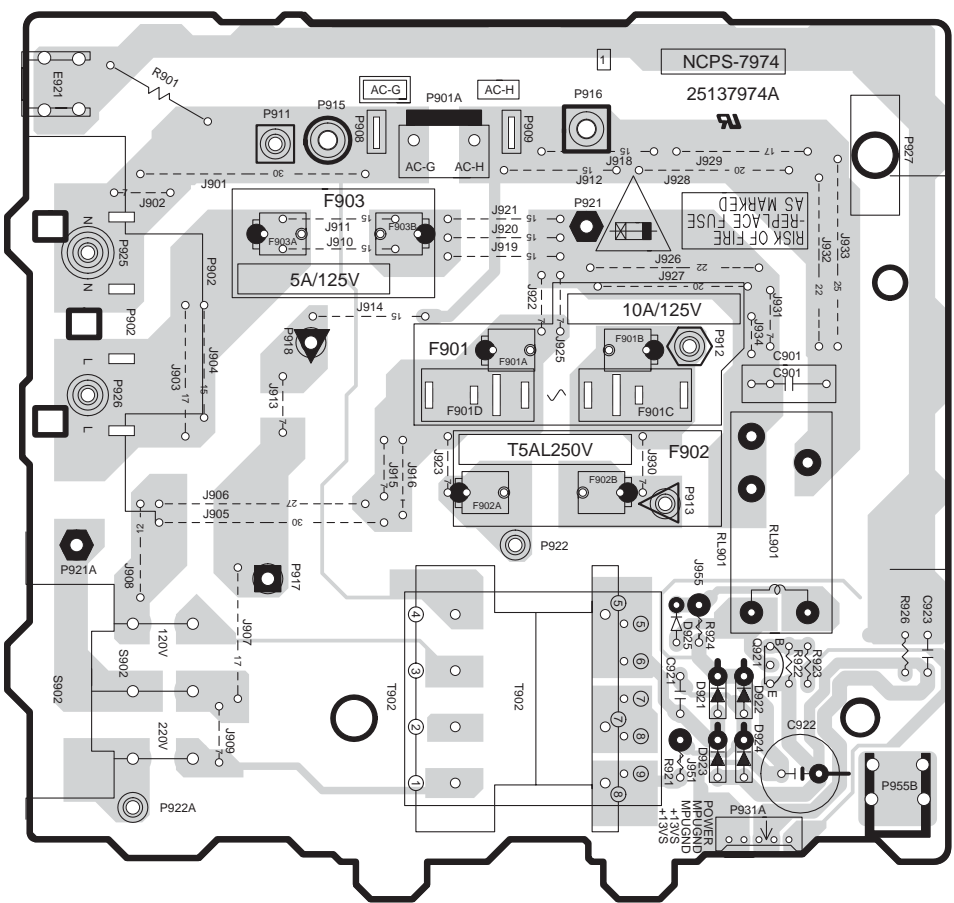

PRIMARY CIRCUIT PC BOARD (NAPS-7974)

U26

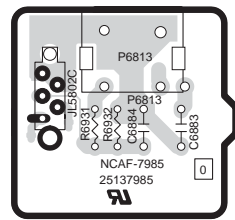

PRE-OUTPUT TERMINAL PC BOARD (NAAF-7985)

A B C D

PRINTED CIRCUIT BOARD VIEW 5

U22

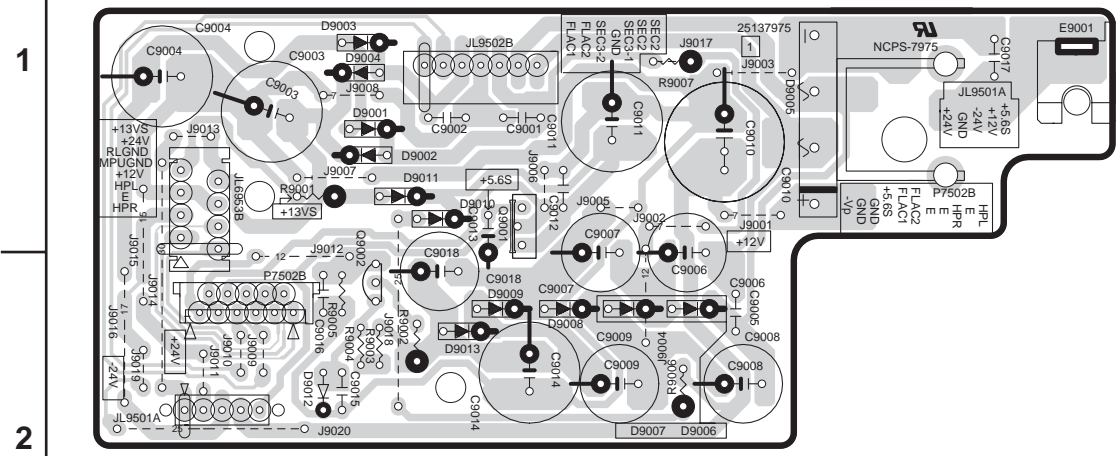

CONSTANT VOLTAGE CIRCUIT PC BOARD
(NAPS-7975)

U31

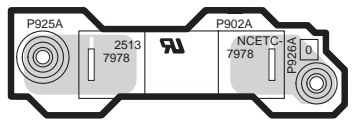

AC OUTLET TERMINAL PC BOARD
(NAETC-7978)
Korean model only

U23

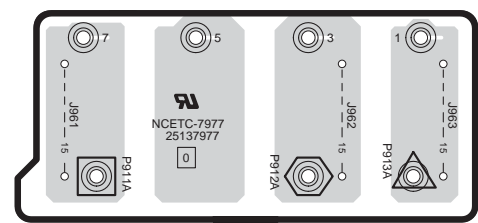

PRIMARY TERMINAL PC BOARD
(NAETC-7977)

U15

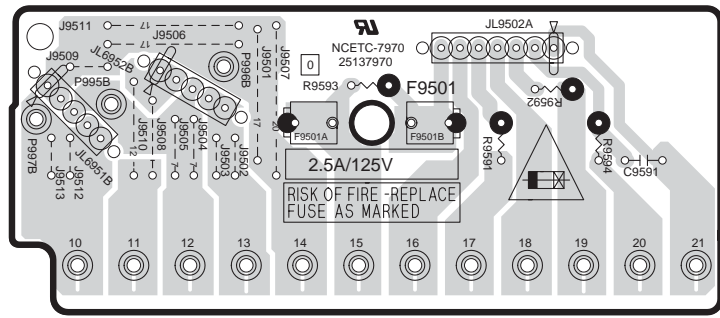

SECONDARY TERMINAL PC BOARD
(NAETC-7970)

U30

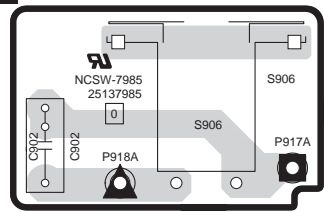

POWER SWITCH PC BOARD
(NASW-7987)
Except 120V and Australian
models

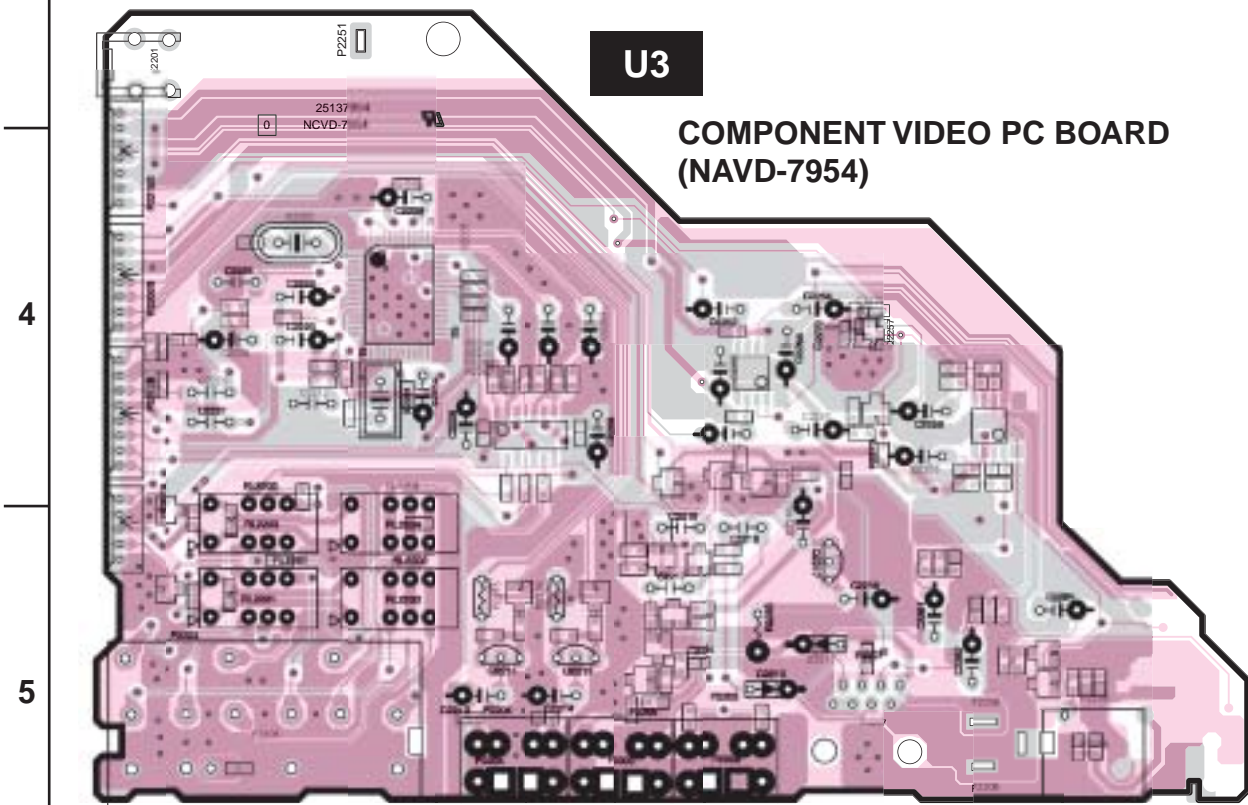
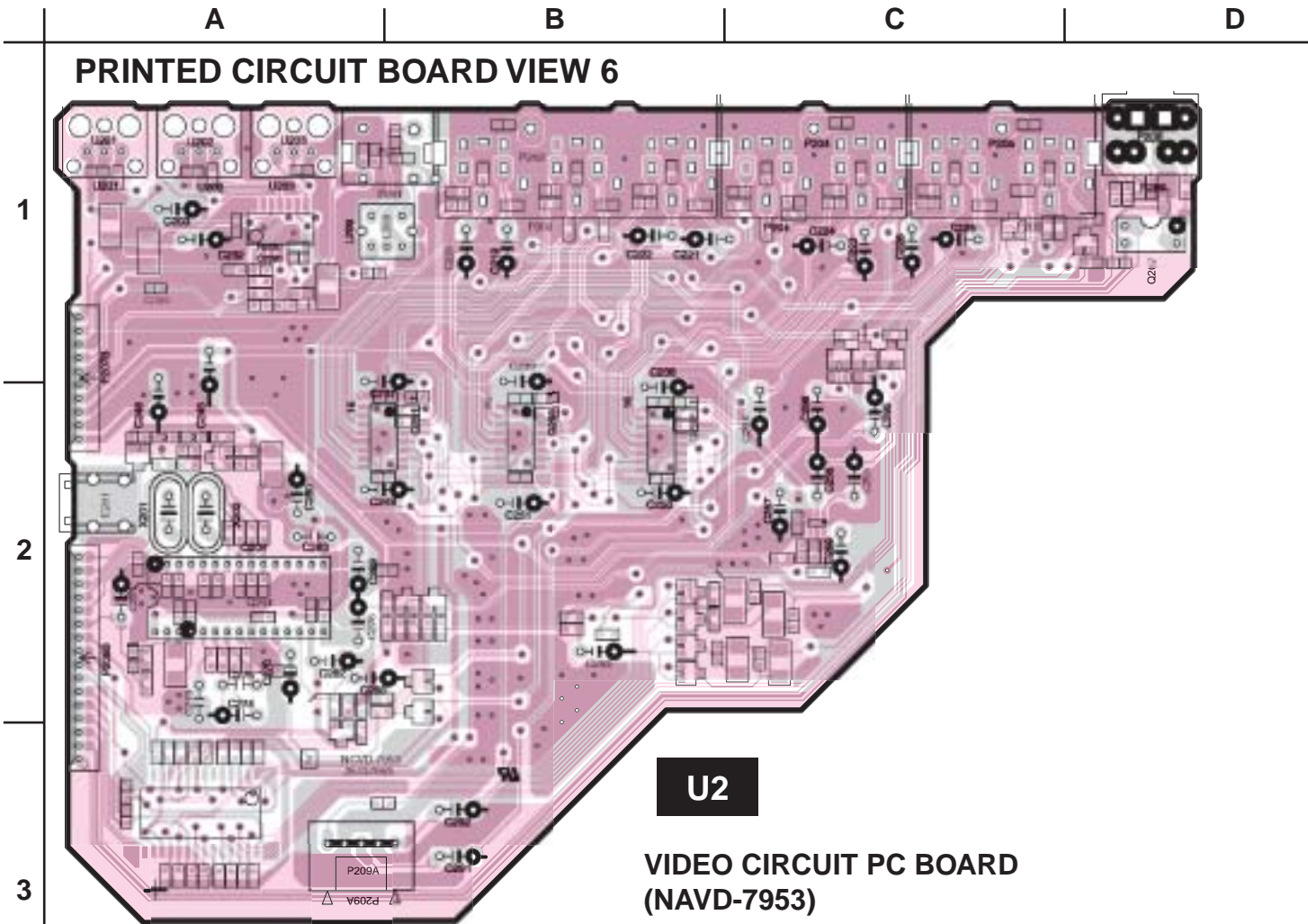

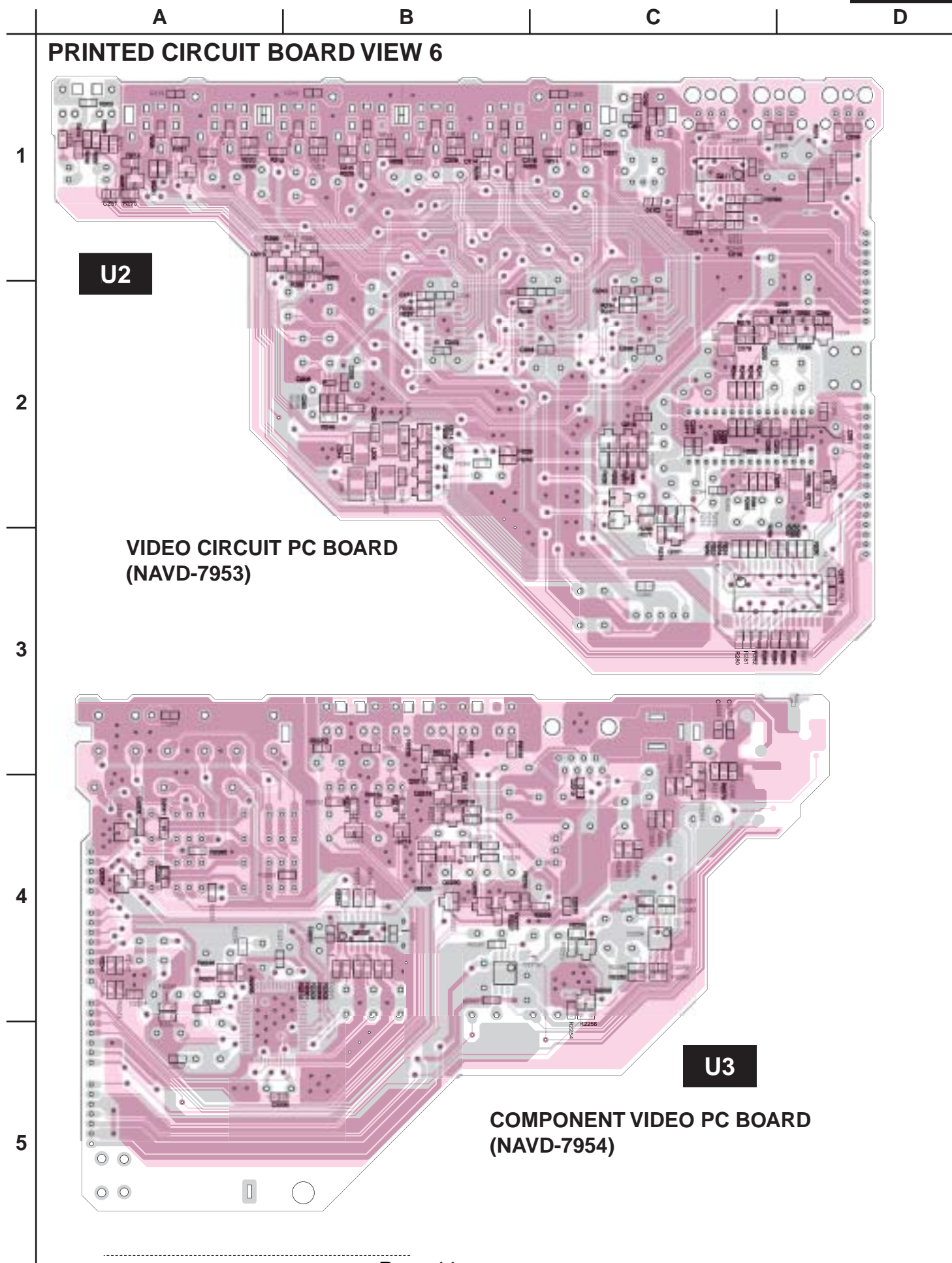

PRINTED CIRCUIT BOARD VIEW 6

U2

**VIDEO CIRCUIT PC BOARD
(NAVD-7953)**

U3

**COMPONENT VIDEO PC BOARD
(NAVD-7954)**

IC BLOCK DIAGRAMS AND DESCRIPTIONS

TC9274F-020 (Analog switch)

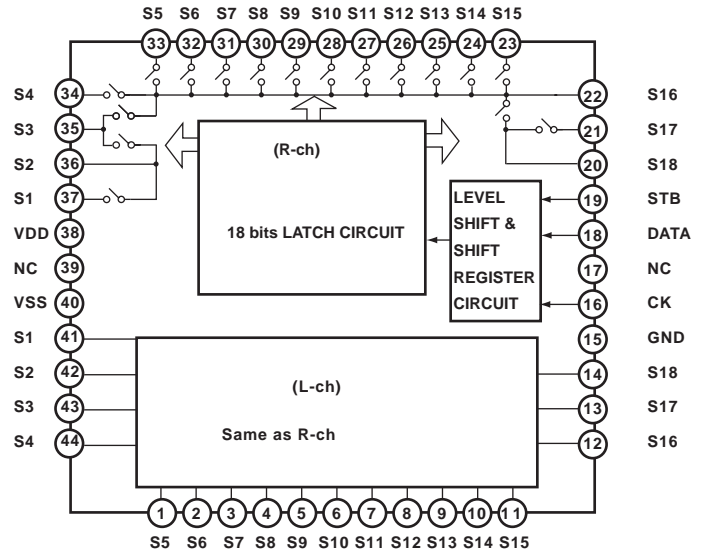
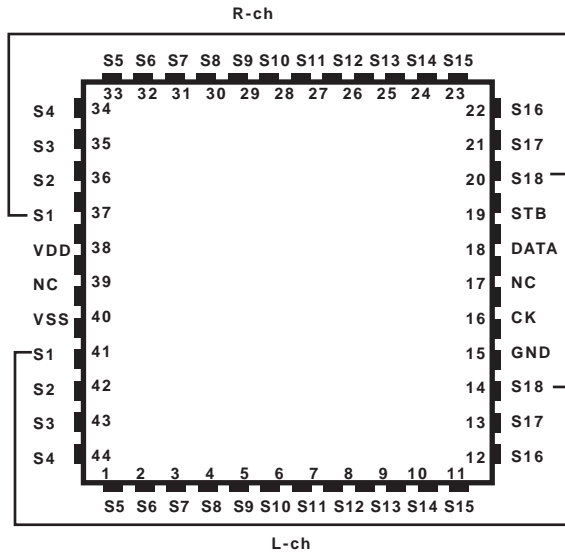

TC74VHC74FT (Dual D-FF with preset and clear)

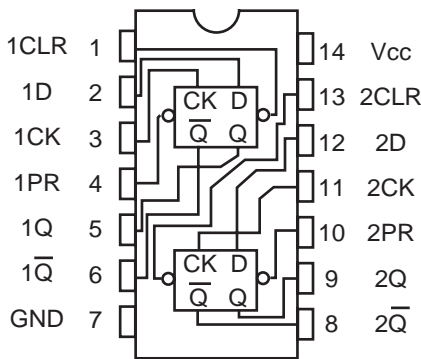

INPUTS				OUTPUTS		FUNCTION
CLR	PR	D	CK	Q	Q̄	
L	H	X	X	L	H	CLEAR
H	L	X	X	H	L	PRESET
L	L	X	X	H	H	————
H	H	L	↑	L	H	————
H	H	H	↑	H	L	————
H	H	X	↓	Q _n	Q _n	NO CHANGE

X: Don't care

74VHC04FT (Hex Inverter)

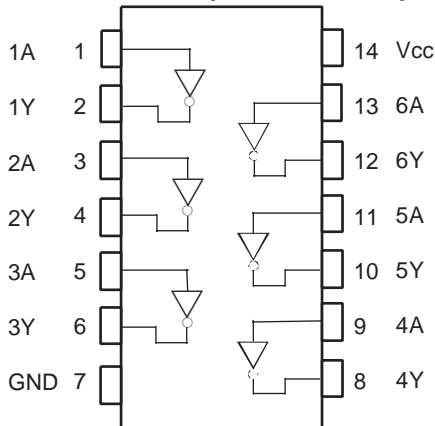

(TOP VIEW)

Truth table

A	Y
L	H
H	L

IC BLOCK DIAGRAMS AND DESCRIPTIONS

BD3811K1(6ch Volume with 8ch input selector)

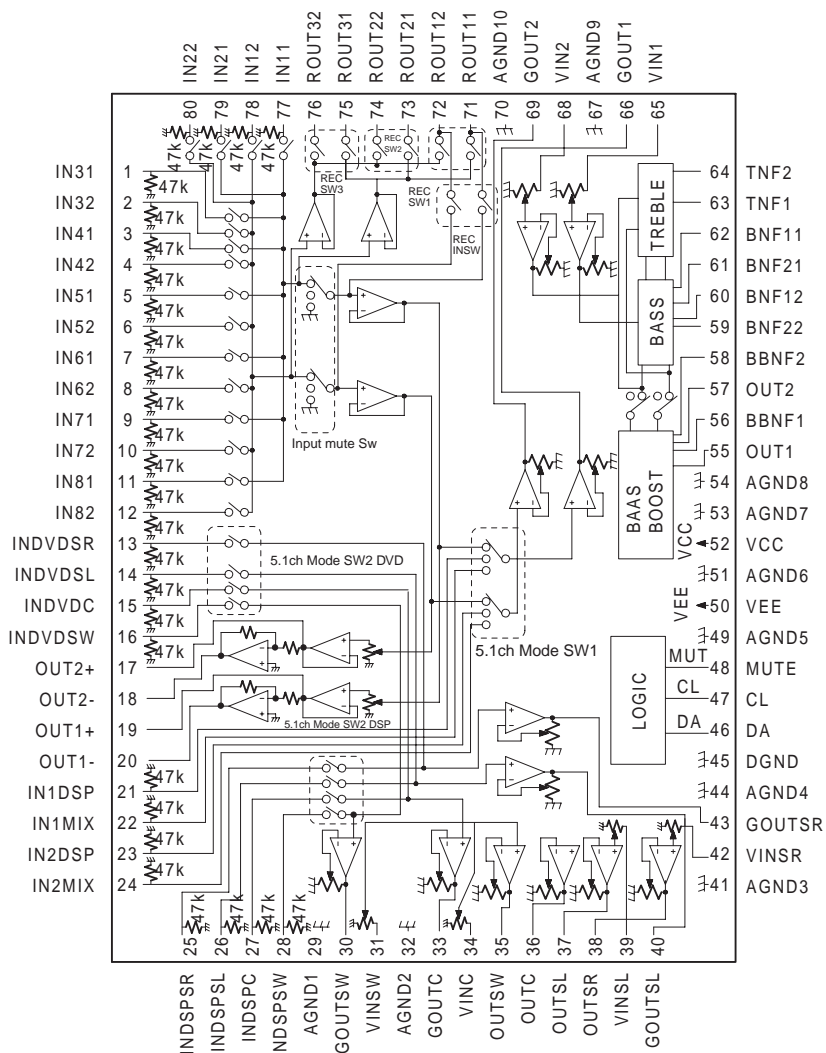

No.	Terminal	Description
26	INDSPSL	DSP surround Lch input terminal
27	INDSPC	DSP center input terminal
28	INDSPSW	DSP sub woofer input terminal
29	AGND1	Analog ground terminal
30	GOUTSW	Sub woofer input gain output terminal
31	VINSW	Sub woofer volume input terminal
32	AGND2	Analog ground terminal
33	GOUTC	Center input gain out put terminal
34	VINC	Center volume input terminal
35	OUTSW	Sub woofer output terminal
36	OUTC	Center output terminal
37	OUTSL	Surround Lch output terminal
38	OUTSR	Surround Rch output terminal
39	VINSL	Surround Lch volume input terminal
40	GOUTSL	Surround Lch input gain output terminal
41	AGND3	Analog ground terminal
42	VINSR	Surround Rch volume input terminal
43	GOUTSR	Surround Rch input gain output terminal
44	AGND4	Analog ground terminal
45	DGND	Ground terminal for comparator
46	DA	Serial data and latch input terminal
47	CL	Serial clock input terminal
48	MUTE	Mute terminal
49	AGND5	Analog ground terminal
50	VEE	(-) Power supply terminal
51	AGND6	Analog ground terminal
52	VCC	(+) Power supply terminal
53	AGND7	Analog ground terminal
54	AGND8	Analog ground terminal
55	OUT1	1ch output terminal
56	BBNF1	1ch bass boost filter terminal
57	OUT2	2ch output terminal
58	BBNF2	2ch bass boost filter terminal
59	BNF22	2ch bass filter terminal 2
60	BNF12	2ch bass filter terminal 1
61	BNF21	1ch bass filter terminal 2
62	BNF11	1ch bass filter terminal 1
63	TNF1	1ch treble filter terminal 1
64	TNF2	2ch treble filter terminal 1
65	VIN1	1ch(Lch) volume input terminal
66	GOUT1	1ch(Lch) input gain output terminal
67	AGND9	Analog ground terminal
68	VIN2	2ch(Rch) volume input terminal
69	GOUT2	2ch(Rch) input gain output terminal
70	AGND10	Analog ground terminal
71	ROUT11	1ch recording input/output terminal 1
72	ROUT12	2ch recording input/output terminal 1
73	ROUT21	1ch recording output terminal 2
74	ROUT22	2ch recording output terminal 2
75	ROUT31	1ch recording output terminal 3
76	ROUT32	2ch recording output terminal 3
77	IN11	1ch input terminal 1
78	IN12	2ch input terminal 1
79	IN21	1ch input terminal 2
80	IN22	2ch input terminal 2

No.	Terminal	Description
1	IN31	1ch input terminal 3
2	IN32	2ch input terminal 3
3	IN41	1ch input terminal 4
4	IN42	2ch input terminal 4
5	IN51	1ch input terminal 5
6	IN52	2ch input terminal 5
7	IN61	1ch input terminal 6
8	IN62	2ch input terminal 6
9	IN71	1ch input terminal 7
10	IN72	2ch input terminal 7
11	IN81	1ch input terminal 8
12	IN82	2ch input terminal 8
13	INDVDSR	DVD surround Rch input terminal
14	INDVDSL	DVD surround Lch input terminal
15	INDVDC	DVD center input terminal
16	INDVDSW	DVD sub woofer input terminal
17	OUT2(+)	2ch (+) A/D output terminal
18	OUT2(-)	2ch (-) A/D output terminal
19	OUT1(+)	1ch (+) A/D output terminal
20	OUT1(-)	1ch (-) A/D output terminal
21	IN1DSP	1ch DSP input terminal
22	IN1MIX	1ch DSP MIX input terminal
23	IN2DSP	2ch DSP input terminal
24	IN2MIX	2ch DSP MIX input terminal
25	INDSPSR	DSP surround Rch input terminal

IC BLOCK DIAGRAMS AND DESCRIPTIONS

LC74763-9836(On-screen and controller)

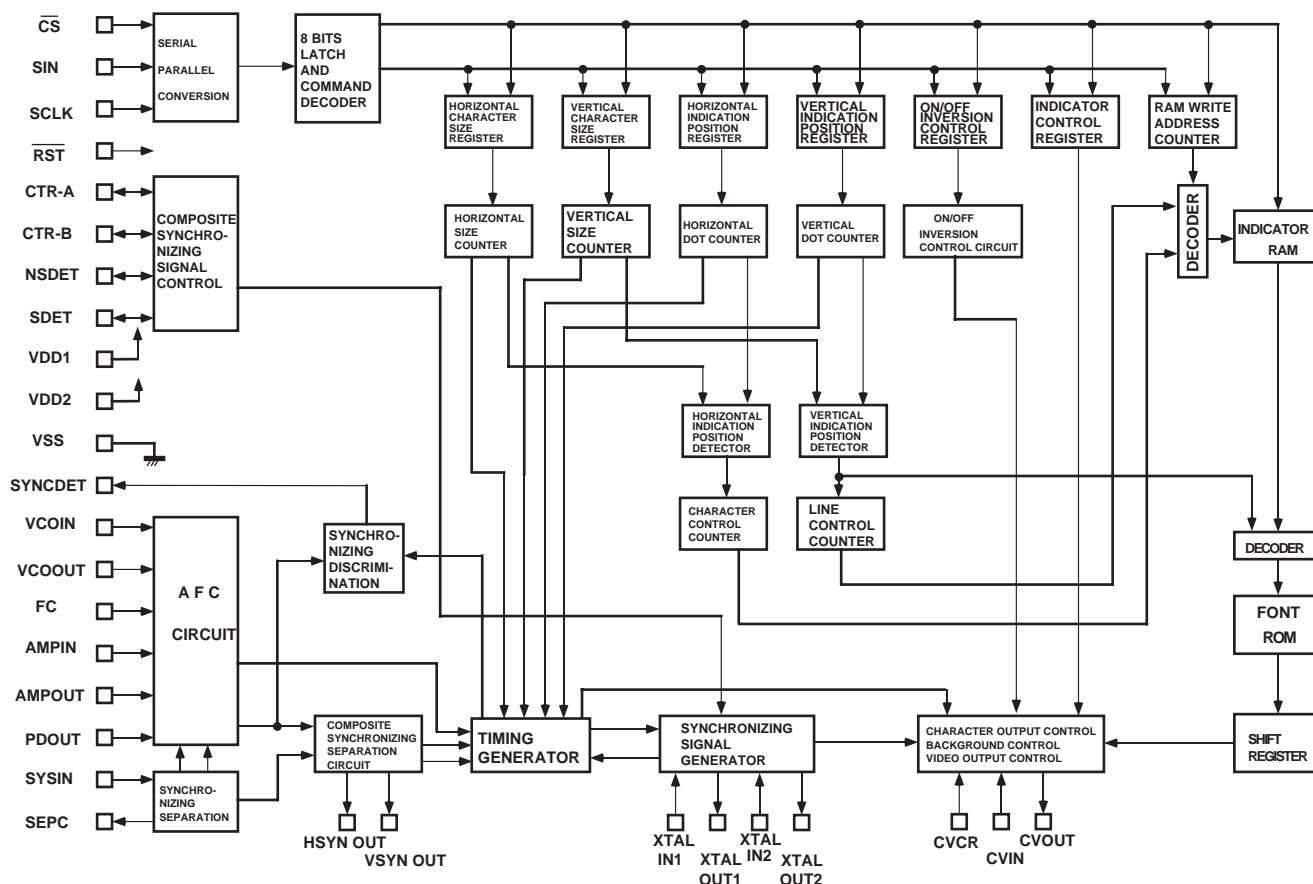

No.	Symbol	Description	No.	Symbol	Description
1	VSS	Ground terminal	16	CVOUT	Composite video output terminal
2	XTALIN1	Crystal oscillator connection terminals for.	17	VDD2	Power supply terminal for composite video signal
3	XTALOUT1	internal synchronizing signal generator	18	CVIN	Composite video signal input terminal
4	HSYNOUT	Horizontal synchronizing signal output terminal	19	CVCR	Chromatic signal input terminal
5	XTALIN2	Crystal oscillator connection terminals for.	20	SYNCIN	Video signal input terminal for internal synchronizing separation circuit
6	XTALOUT2	internal synchronizing signal generator	21	SEPC	Bias output pin for internal synchronizing separation circuit
7	VSYNOUT	Vertical synchronizing signal output terminal	22	VSS	Ground terminal
8	CS	Chip enable input terminal	23	PDOUT	Power supply output terminal for AFC circuit
9	SIN	Serial data input terminal	24	AMPIN	Filter connection terminals
10	SCLK	Clock input terminal for serial data	25	AMPOUT	
11	CTR-A	Video control output terminal	26	FC	Power supply output terminal
12	CTR-B	Video control output terminal	27	VCOIN	LC resonator connection terminals for VCO
13	NSDET	Selection pin for PAL or NTSC	28	VCOOUT	
14	SDET	Signal detection terminal	29	SYNCDET	External synchronizing signal discrimination output terminal
15	RST	System reset input terminal	30	VDD1	Power supply terminal

IC BLOCK DIAGRAMS AND DESCRIPTIONS

LC72723M(RDS demodulator)

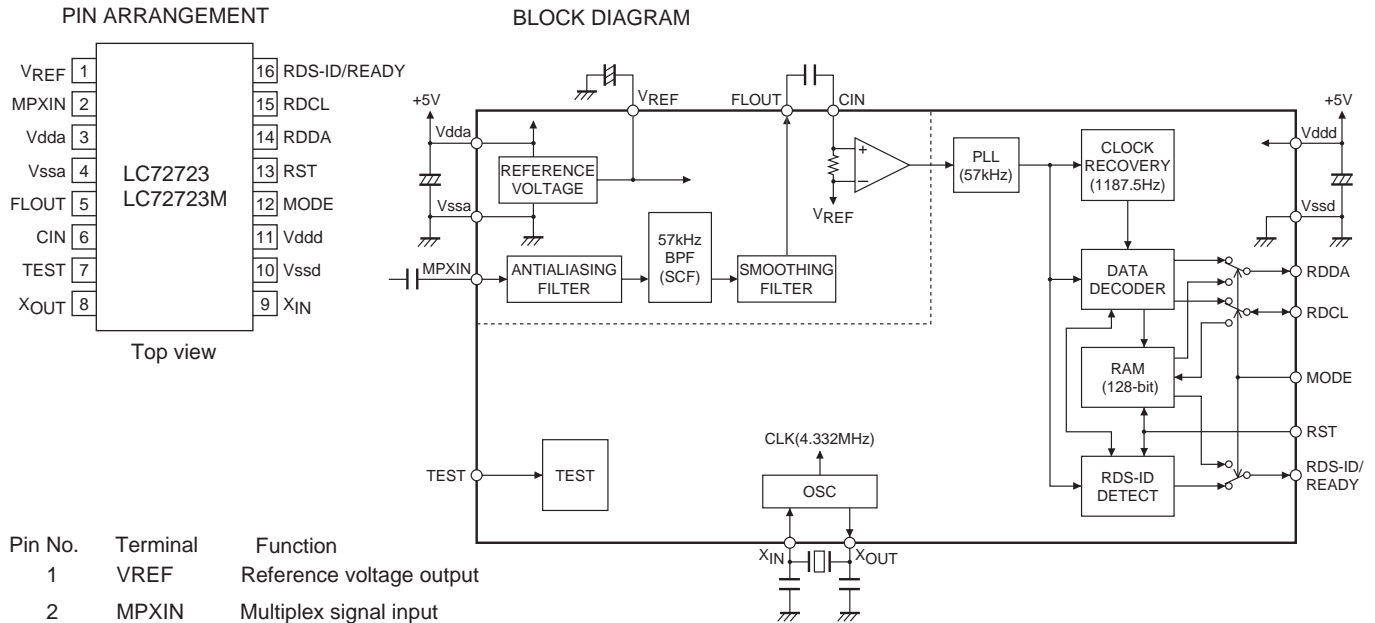

Pin No.	Terminal	Function
1	VREF	Reference voltage output
2	MPXIN	Multiplex signal input
3	Vdda	Analog power source (+5V)
4	Vssa	Analog ground
5	FLOUT	Sub-carrier output (Filter output)
6	CIN	Sub-carrier input(Comparator output)
7	TEST	Test input
8	XOUT	4.332MHz Crystal connection pin
9	XIN	Crystal or external reference signal input
10	Vssd	Digital ground
11	Vddd	Digital power supply
12	MODE	Read mode setting
13	RST	RDS-ID/RAM reset
14	RDDA	RDS data output
15	RDCL	RDS clock output (Master mode)/input (Slave mode)
16	RDS-ID/READY	RDS-ID/READY output

MM1512(Y-C mixer circuit)

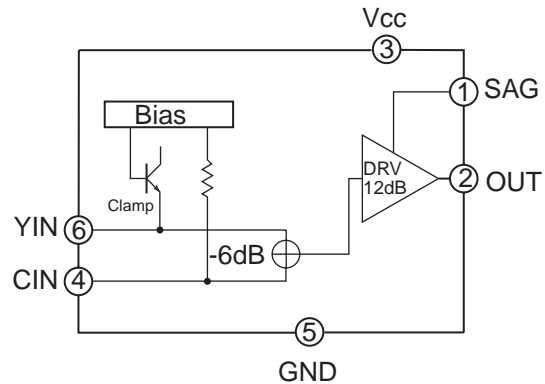

NJM2595M(5-Input, 3-Output Video Switch)

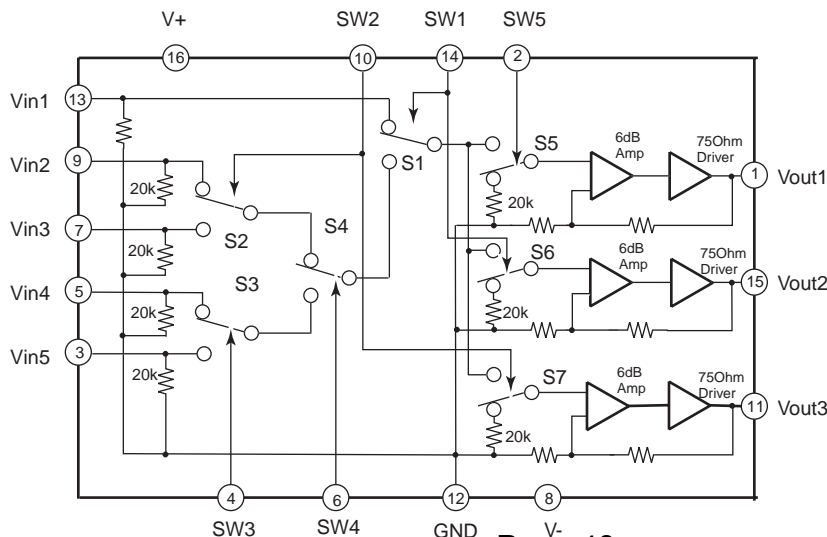

IC BLOCK DIAGRAMS AND DESCRIPTIONS

BD3812F(Audio Sound Processor)

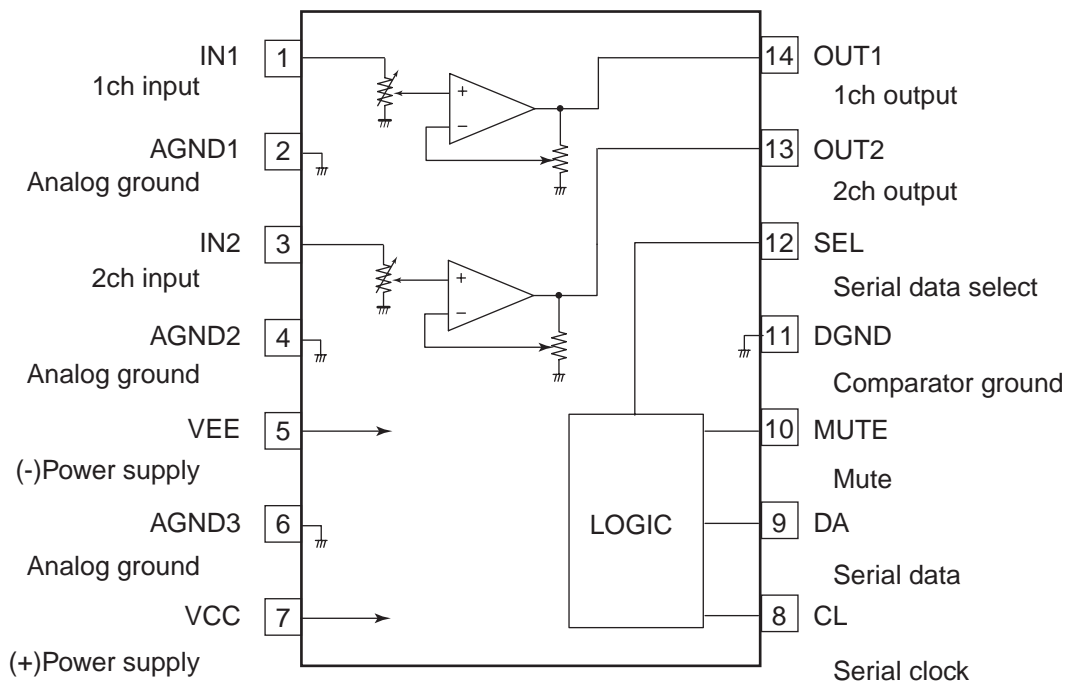

CY7C1019BV/CV33-15VCT(128KX8 static RAM)

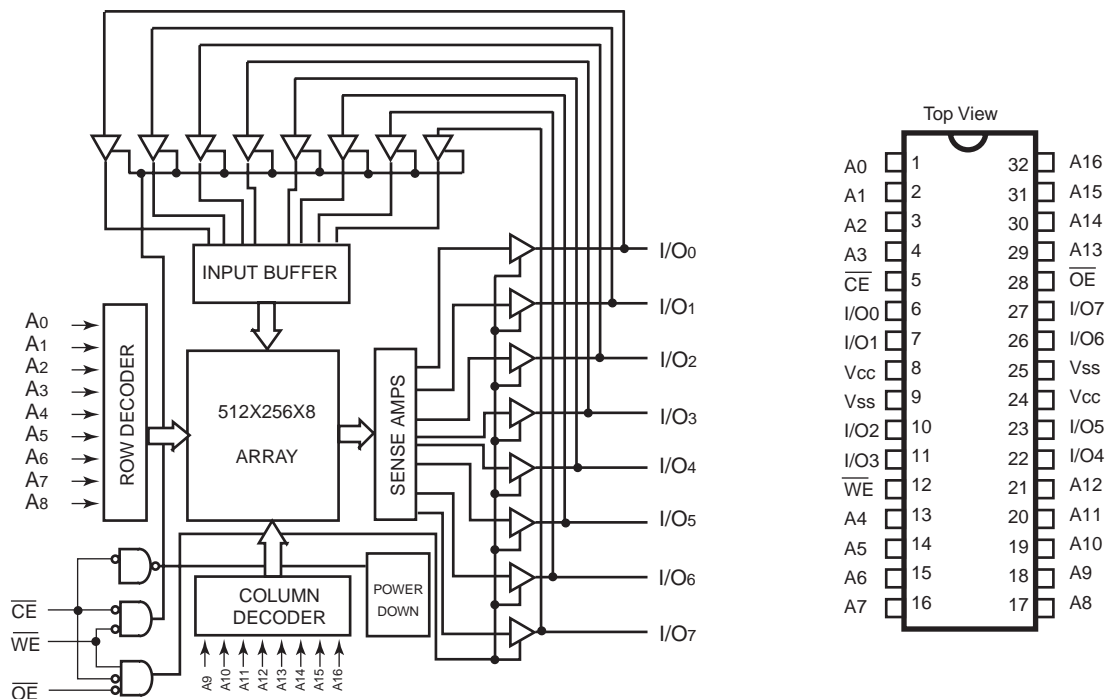

IC BLOCK DIAGRAMS AND DESCRIPTIONS

TC9164AF(Function switch)

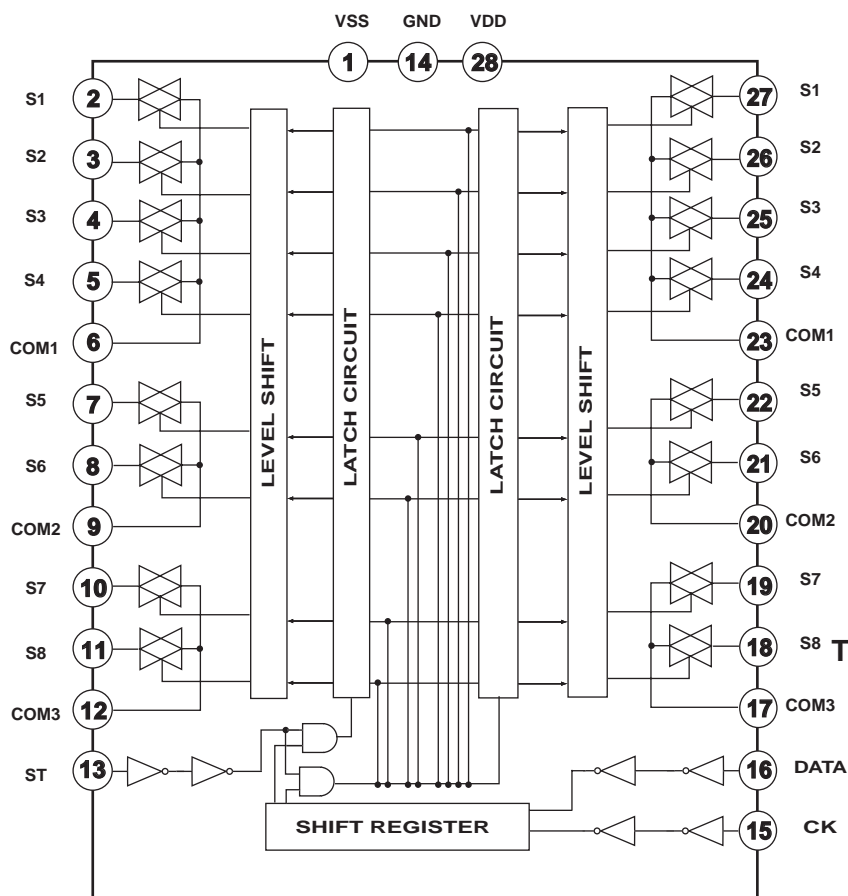

Pin No.	Symbol	Function
1	Vss	Negative power supply
14	GND	Ground
28	VDD	Positive power supply
2,3,4,6,7,8,10,11	S1-S8	Input/output terminals
27,26,25,23,22,21,19,18	S1-S8	Input/output terminals
5,9,12	COM1 - COM3	Common terminals
24,20,17	COM1 - COM3	Common terminals
13	ST	Strobe input terminal for data reading
15	CK	Clock input terminal for data transfer
16	DATA	Data input terminal for switch

74HCU04F(Hex Inverters)

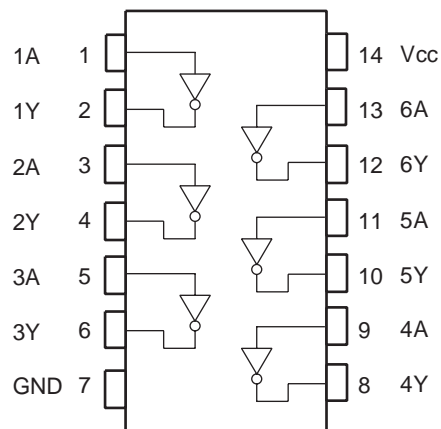

Truth table (TOP VIEW)

A	Y
L	H
H	L

TC74VHCT00AFT(2-input NAND gate)

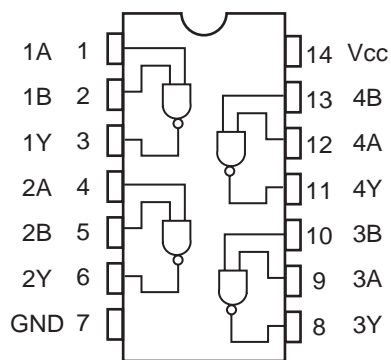

A	B	Y
L	L	H
L	H	H
H	L	H
H	H	L

TC7WU04F(3 Inverters)

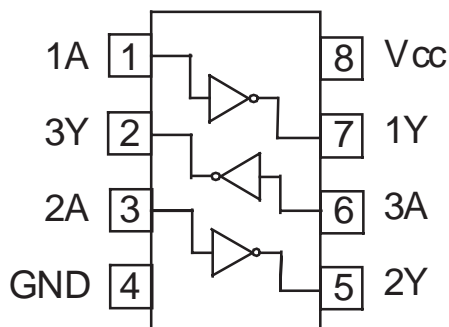

Truth table

A	Y
L	H
H	L

IC BLOCK DIAGRAMS AND DESCRIPTIONS

CS42518(192 kHz 8-Ch Codec with S/P DIF Receiver)

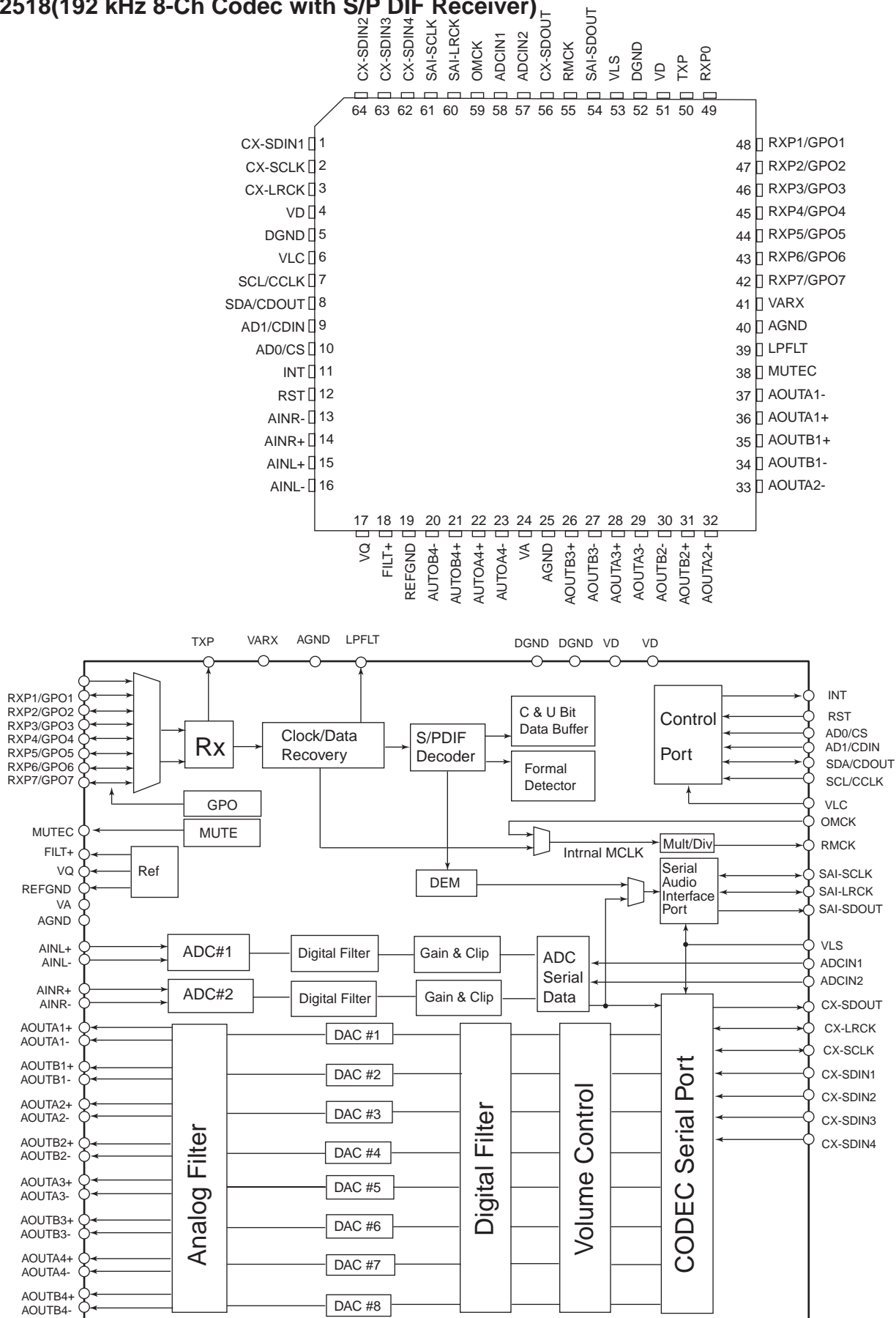

SUB-MICROPROCESSOR CONNECTION DIAGRAM

1

2

3

4

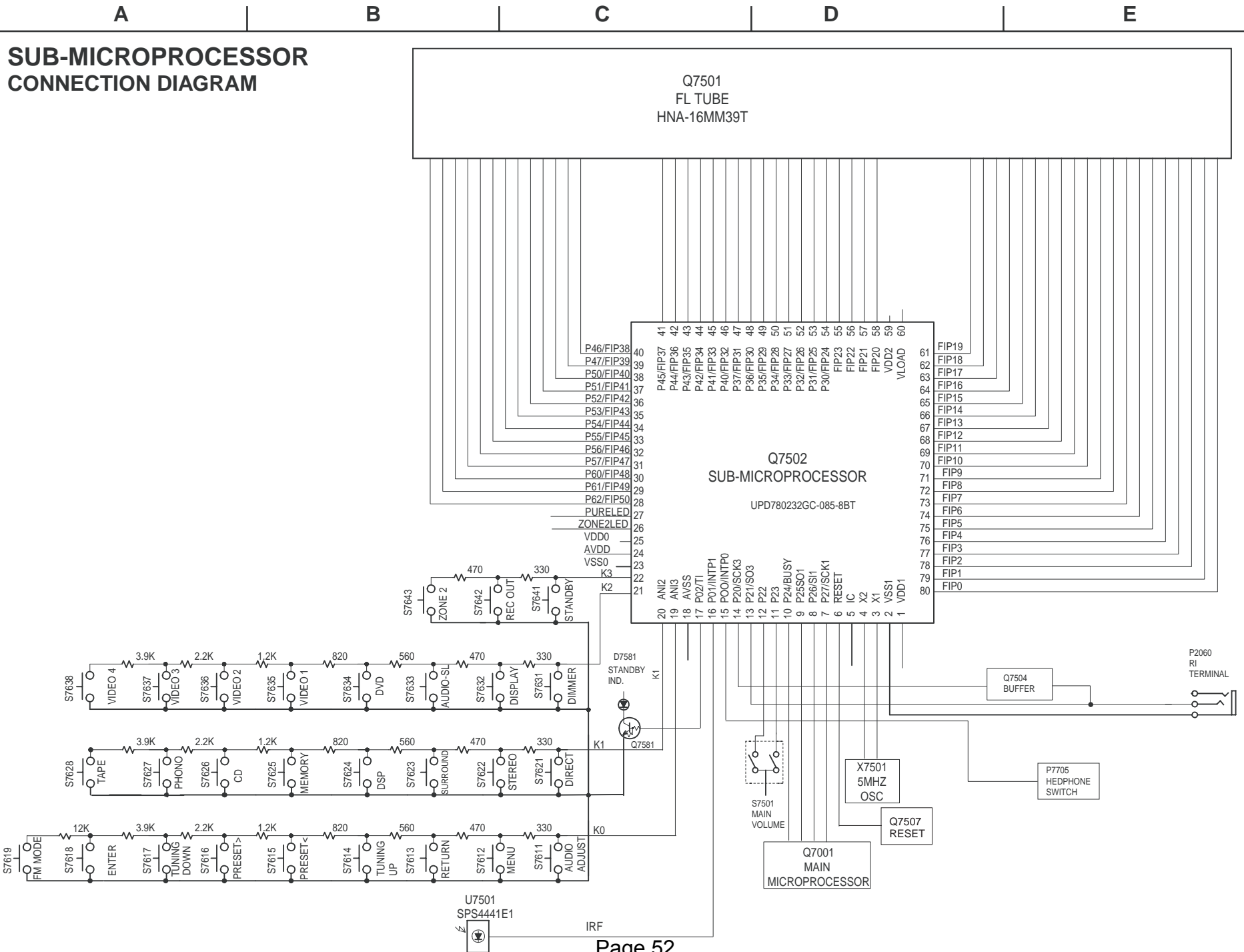

A B C D

MAIN MICROPROCESSOR CONNECTION DIAGRAM

1

2

3

4

5

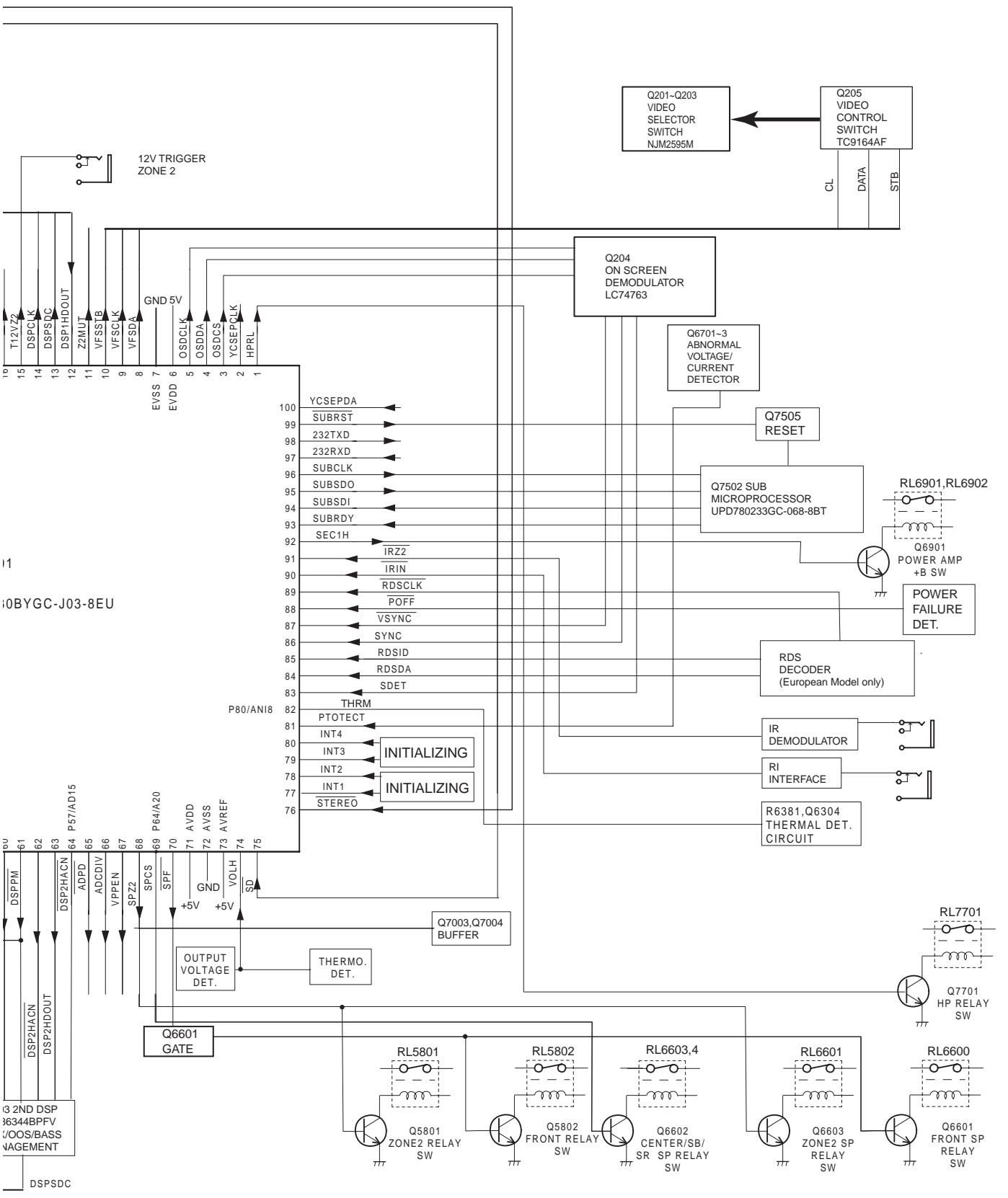

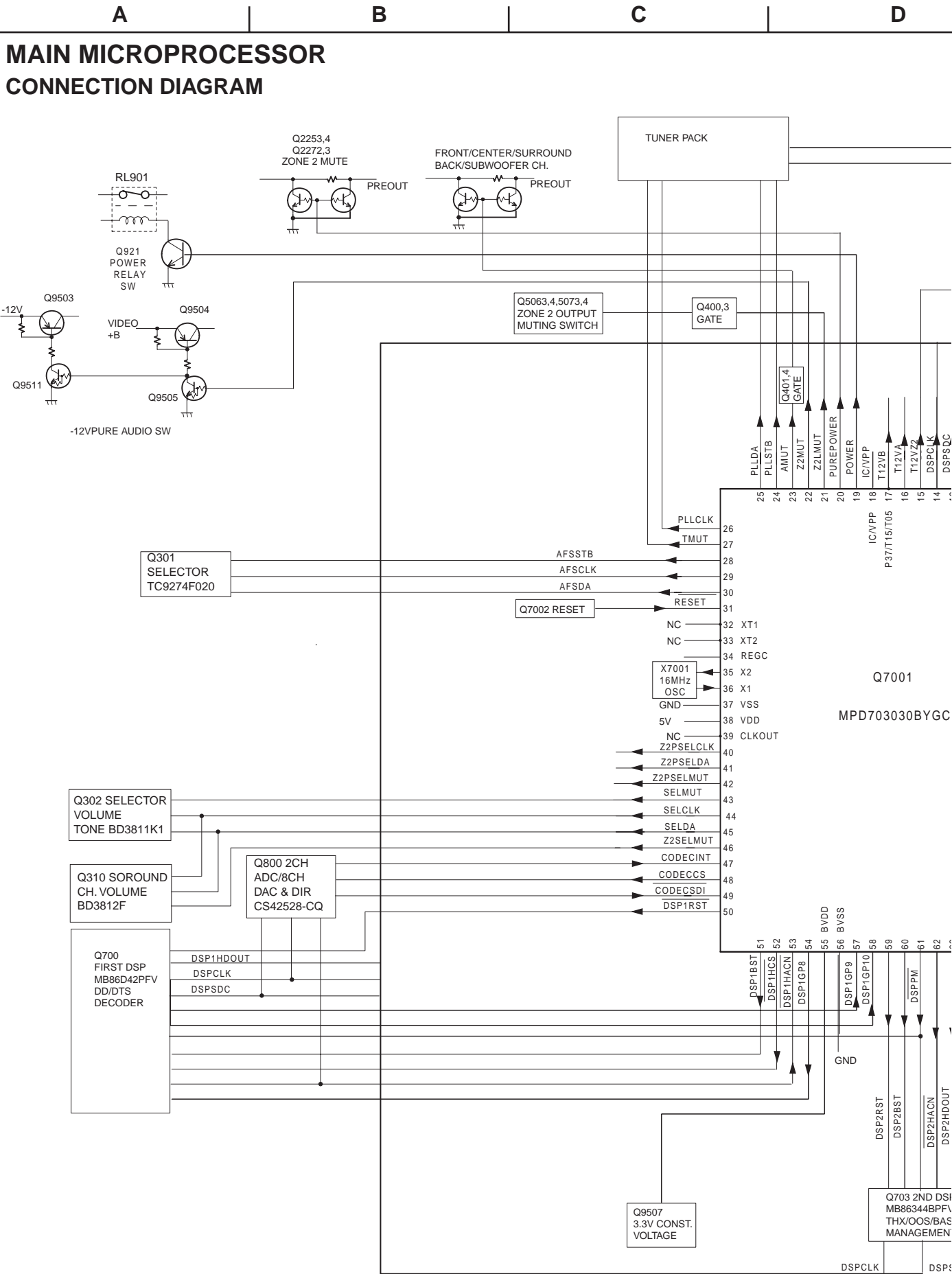

TERMINAL DESCRIPTION

SUB MICROPROCESSOR

Pin No.	Symbol	I/O	Description	Pin No.	Symbol	I/O	Description
1	VDD		Power supply terminal. Connect to 5V.	41	P22	O	Segment output terminal of P22.
2	VSS		Ground terminal.	42	P21	O	Segment output terminal of P21.
3	X1		Ceramic oscillator connection terminals for main system.	43	P20	O	Segment output terminal of P20.
4	X2		Connect the 5MHz ceramic oscillator between #3 and #4.	44	P19	O	Segment output terminal of P19.
5	IC/VPP		Internal connection terminal	45	P18	O	Segment output terminal of P18.
6	~RESET	I	System reset signal input terminal.	46	P17	O	Segment output terminal of P17.
7	SUBCL/SCK	I	Clock input terminal to transmit the signal from main microprocessor.	47	P16	O	Segment output terminal of P16.
8	SUBDO/SDI	I	Data input terminal to transmit the signal from main microprocessor.	48	P15	O	Segment output terminal of P15.
9	SUBDI/SDD	O	Data output terminal to transmit the signal to main microprocessor.	49	P14	O	Segment output terminal of P14.
10	SUBLDY	O	Data ready output terminal to transmit to the main microprocessor.	50	P13	O	Segment output terminal of P13.
11	VBJ	I	Pulse input terminal from the rotary encoder of volume.	51	P12	O	Segment output terminal of P12.
12	VAJ	I	Pulse input terminal from the rotary encoder of volume.	52	P11	O	Segment output terminal of P11.
13	SYSIN	I	System code input terminal.	53	P10	O	Segment output terminal of P10.
14	SYSOUT	I	System code output terminal.	54	P9	O	Segment output terminal of P9.
15	HPDET	I	Detection terminal of headphone insertion.	55	P8	O	Segment output terminal of P8.
16	~IRIN	I	Signal input terminal from the remote controller.	56	P7	O	Segment output terminal of P7.
17	STBYLED	O	Standby LED control output terminal.	57	P6	O	Segment output terminal of P6.
18	AVSS		Ground terminal for A/D converter.	58	P5	O	Segment output terminal of P5.
19	K0	I	Operation key connection terminal.	59	VDD2		Power supply terminal. Apply +5V.
20	K1	I	Operation key connection terminal.	60	VLOAD		Negative power supply terminal of FL controller.
21	K2	I	Operation key connection terminal.	61	P4	O	Segment output terminal of P4.
22	K3	I	Operation key connection terminal.	62	P3	O	Segment output terminal of P3.
23	VSS0		Ground terminal	63	P2	O	Segment output terminal of P2.
24	AVDD		Power supply terminal for A/D converter.	64	P1	O	Segment output terminal of P1.
25	VDDD		Power supply terminal. Apply +5V.	65	16G	O	Grid output terminal of 16G.
26	ZONE2LED	O	Not used.	66	15G	O	Grid output terminal of 15G.
27	PURELED	O	Not used.	67	14G	O	Grid output terminal of 14G.
28	P35	O	Segment output terminal of P35.	68	13G	O	Grid output terminal of 13G.
29	P34	O	Segment output terminal of P34.	69	12G	O	Grid output terminal of 12G.
30	P33	O	Segment output terminal of P33.	70	11G	O	Grid output terminal of 11G.
31	P32	O	Segment output terminal of P32.	71	10G	O	Grid output terminal of 10G.
32	P31	O	Segment output terminal of P31.	72	9G	O	Grid output terminal of 9G.
33	P30	O	Segment output terminal of P30.	73	8G	O	Grid output terminal of 8G.
34	P29	O	Segment output terminal of P29.	74	7G	O	Grid output terminal of 7G.
35	P28	O	Segment output terminal of P28.	75	6G	O	Grid output terminal of 6G.
36	P27	O	Segment output terminal of P27.	76	5G	O	Grid output terminal of 5G.
37	P26	O	Segment output terminal of P26.	77	4G	O	Grid output terminal of 4G.
38	P25	O	Segment output terminal of P25.	78	3G	O	Grid output terminal of 3G.
39	P24	O	Segment output terminal of P24.	79	2G	O	Grid output terminal of 2G.
40	P23	O	Segment output terminal of P23.	80	1G	O	Grid output terminal of 1G.

MAIN MICROPROCESSOR

TERMINAL DESCRIPTION

No.	Symbol	I/O	Description
51	DSP1BST	O	Boot strap output pin for first DSP IC.
52	~DSP1HCS	O	Serial communication clock output pin for Q302 and Q310.
53	~DSP1HACN	I	Acknowledge input pin for first DSP IC.
54	DSP1GP8	O	PCM information output pin for first DSP IC.
55	BVdd		Power supply pin (3.3V)
56	BVss		Ground pin
57	DSP1GP9	I	Information input pin to read bit stream information of first DSP IC.
58	GSP1GP10	I	Interrupter request input pin for first DSP IC
59	~DSP2RST	O	Reset signal output pin for second DSP IC Q703.
60	DSP2BST	O	Boot strap output pin for second DSP IC.
61	~CODECRST/~DSPPM	O	Reset output pin for DIR IC and initializing of PLL of DSP IC
62	~DSP2HACN	I	Acknowledge input pin for second DSP IC.
63	DSP2HDOUT	I	Serial communication data input pin for second DSP IC
64	~DSP2HCS	O	Serial communication clock output pin for second DSP IC
65	~ADPD	O	Power down output pin for AD converter Q113,4.
66	ADCDIV	O	Dividing control output pin for AD converter
67	VppEN	O	Self-write power supply control pin
68	SPZ2	O	Speaker relay control output pin for zone 2
69	SPCS	O	Speaker relay control output pin for center and surround channels
70	SPF	O	Speaker relay control output pin for front channels
71	Avdd		Power supply pin (5V)
72	Avss		Ground pin
73	Avref		Reference voltage pin for A/D converter
74	VOLH	I	Output voltage detection input pin of power amplifier
75	~SD	I	Broadcast detection input pin
76	~STEREO	I	Stereo broadcast detection input pin
77	INIT1	I	Initializing pin
78	INIT2	I	Initializing pin
79	INIT3	I	Initializing pin
80	INIT4	I	Initializing pin
81	PROTECT	I	Abnormal current and voltage detection input pin
82	THRM	I	Thermal detection input pin
83	SDET	I	S video detection input pin
84	RDSDA	I	Data input pin from RDS decoder
85	RDSID	I	Signal input pin from RDS decoder
86	SYNC	I	External synchronizing judgment input pin from OSD IC
87	~VSYNC	I	Vertical synchronizing signal input pin
88	~POFF	I	Power failure detection input pin
89	~RDSCLK	I	Clock input pin from RDS decoder
90	~IRIN	I	IR signal input pin
91	~IRZ2	I	IR signal input pin for zone 2
92	SEC1H	O	Power supply control output pin for power amplifier
93	SUBRDY	I	Ready input pin for sub-microprocessor
94	SUBSDI	I	Serial communication data input pin for sub-microprocessor
95	SUBSDO	O	Serial communication data output pin for sub-microprocessor
96	SUBCLK	O	Serial communication clock output pin for sub-microprocessor
97	232RXD	I	Not used.
98	232TXD	O	Not used.
99	~SUBRST	O	Reset output pin for sub-microprocessor
100	YCSEPDA	O	Not used.

MAIN MICROPROCESSOR

TERMINAL DESCRIPTION

No.	Symbol	I/O	Description
1	HPRL	O	Headphone relay control output pin
2	YCSEPCLK	O	Not used.
3	OSDCS	O	Serial communication chip select output pin for OSD IC Q204.
4	OSDDA	O	Serial communication data output pin for OSD IC.
5	OSDCLK	O	Serial communication clock output pin for OSD IC.
6	Evdd		Power supply pin (5V).
7	Evss		Ground pin
8	VFSDA	O	Serial communication data output pin for video select switch IC Q205.
9	VFSClk	O	Serial communication clock output pin for video select switch IC.
10	VFSSTB	O	Serial communication strobe output pin for video select switch IC.
11	Z2PMUT	O	Muting control output pin for zone 2 pre-output.
12	DSP1HDOUT	I	Serial communication data input pin from first DSP IC Q700.
13	DSPSDO	O	Serial communication data output pin for DSP and DIR ICs.
14	DSPCLK	O	Serial communication clock output pin for DSP and DIR ICs.
15	T12VZ2	O	12V trigger output pin for zone 2.
16	T12VA	O	12V trigger output pin A
17	T12VB	O	12V trigger output pin B
18	IC/Vpp		Test pin
19	POWER	O	Power supply control output pin
20	PUREPOW	O	Power supply control output pin for pure audio
21	Z2LMUT	O	Line output muting control output pin for zone 2
22	Z2MUT	O	Muting control output pin for zone 2
23	AMUT	O	Audio muting control output pin
24	PLLSTB	O	Serial communication strobe output pin for PLL IC in tuner pack.
25	PLLDATA	O	Serial communication data output pin for PLL IC.
26	PLLCLK	O	Serial communication clock output pin for PLL IC.
27	TMUT	O	Muting control output pin for tuner pack.
28	AFSSTB	O	Serial communication strobe output pin for select switch IC Q301.
29	AFSSCK	O	Serial communication clock output pin for select switch IC Q301.
30	AFSDA	O	Serial communication data output pin for select switch IC Q301.
31	~RESET	I	System reset input
32	XT1		Not used.
33	XT2		Not used.
34	REGC		Regulator adjustment capacitor connection pin
35	X2		Main clock connection pin (16MHz)
36	X1		Main clock connection pin (16MHz)
37	Vss		Ground pin
38	Vdd		Power supply pin (5V).
39	CLKOUT		Not used.
40	Z2PSELCLK	O	Clock output pin for zone 2. Not used.
41	Z2PSELDA	O	Data output pin for zone 2. Not used.
42	Z2PSELMUT	O	Select muting output pin for zone 2. Not used.
43	SELMUT	O	Muting control output pin for audio processor IC Q302.
44	SELCLK	O	Serial communication clock output pin for Q302 and Q310.
45	SELDA	O	Serial communication data output pin for Q302 and Q310.
46	Z2SELMUT	O	Muting control output pin for volume control IC Q310.
47	CODECINT	I	Error detection input pin for DIR IC Q800.
48	~CODECCS	O	Serial communication chip select output pin for DIR IC.
49	CODECSDI	I	Serial communication data input pin for DIR IC.
50	~DSP1RST	O	Reset signal output pin for first DSP IC Q700.

ADJUSTMENT AND CONFIRMATION PROCEDURES 2

3. Confirmation of Current detection circuit

Set the unit to "Test-1-00".

Connect the differentiating circuit and apply the 200Hz square signal to DVD INPUT terminal of each channel.

Adjust the attenuator or Volume so that the output level becomes 35V p-p.

Confirm that the speaker relay does not turn OFF when a 3.0 ohm load is connected.

Confirm that the speaker relay turns off when a 1.5 ohm load is connected.

Caution: Don't continue more than 3 seconds.

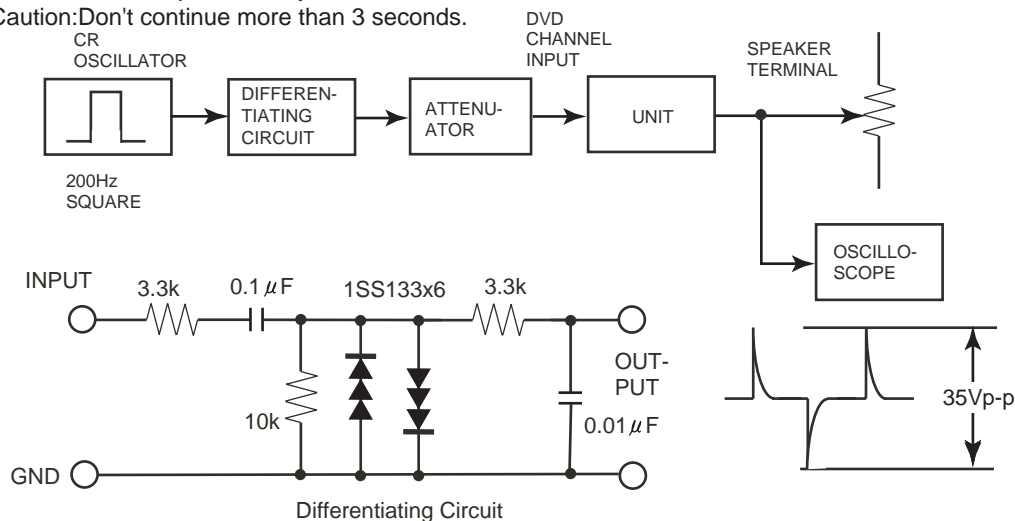

Set the unit to "Test-1-02".

Connect the differentiating circuit and apply the 200Hz square signal to the center channel of DVD terminal.

Adjust the attenuator or Volume so that the output level of surround back becomes 35V p-p.

Confirm that the speaker relay does not turn OFF when a 3.0 ohm load is connected.

Confirm that the speaker relay turns off when a 1.5 ohm load is connected.

Caution: Don't continue more than 3 seconds.

Test Mode

1. Turn POWER button on.
2. Press and hold down CD button, then press STANDBY/ON button.
3. After "Test-1" on the FL tube is displayed, press CD button to set the unit to the Test mode of FL tube.

Note: VIDEO 1: Test-1 VIDEO 2: Test-2 REC OUT: UP
VIDEO 3: Test-3 VIDEO 4: Test-4 ZONE 2: DOWN

Test mode of FL tube

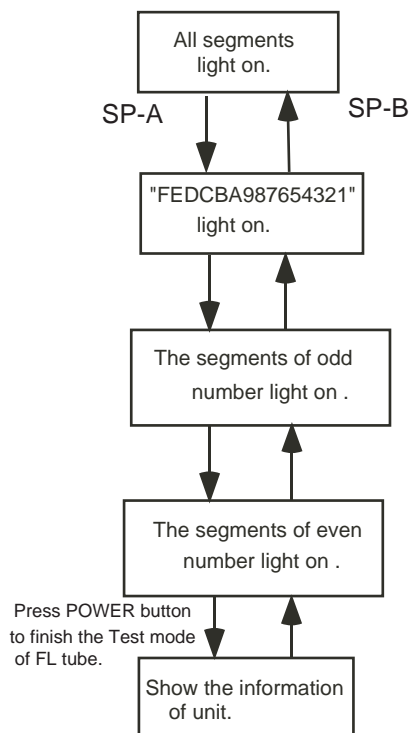

Confirmation of voltage sensor

1. Set the unit to Test-4-35 or Test-4-36.
2. Confirm that the FM STEREO is displayed.
Confirm that the speaker relays of RL6901 and RL6902 turn off.
3. When connect the resistor 2.7 kohm/1 W between the terminals COM and TH1 of P6301, confirm that "FM STEREO" light on.
Note: No input signal.
4. When connect the resistor 2.2 kohm/1 W between the terminals of P6302, confirm that "MEMORY" on FL tube lights on and the protection circuit operates.
Note: No input signal.

ADJUSTMENT AND CONFIRMATION PROCEDURES 1

Idling current adjustment

Before Idling adjustment, turn the trimming resistors R6040 to R6045 to counter clockwise.

Connect the DC voltmeter to sockets P6080 to P6085.

After turn POWER to ON, adjust the trimming resistors R6040, R6041 and R6042 so that the reading of voltmeter becomes 2.5 mV. (Front and center channels)

Adjust the trimming resistors R6043, R6044 and R6045 so that the reading of voltmeter becomes 1.5 mV. (Surround and surround back channels)

After adjustment, attach the top cover.

Confirm the voltage of points above after about five minutes.

Front and center channels

When less than 10.0 mV, readjust the resistors above so that the voltage becomes 10.0 mV.

When 10.0 mV to 12.0 mV, you are not necessary to adjust.

When more than 12.0 mV, readjust the resistors above so that the voltage becomes 12.0 mV.

Surround and surround back channels

When less than 7.0 mV, readjust the resistors above so that the voltage becomes 7.0 mV.

When 7.0 mV to 9.0 mV, you are not necessary to adjust.

When more than 9.0 mV, readjust the resistors above so that the voltage becomes 9.0 mV.

Note: No load and No signal

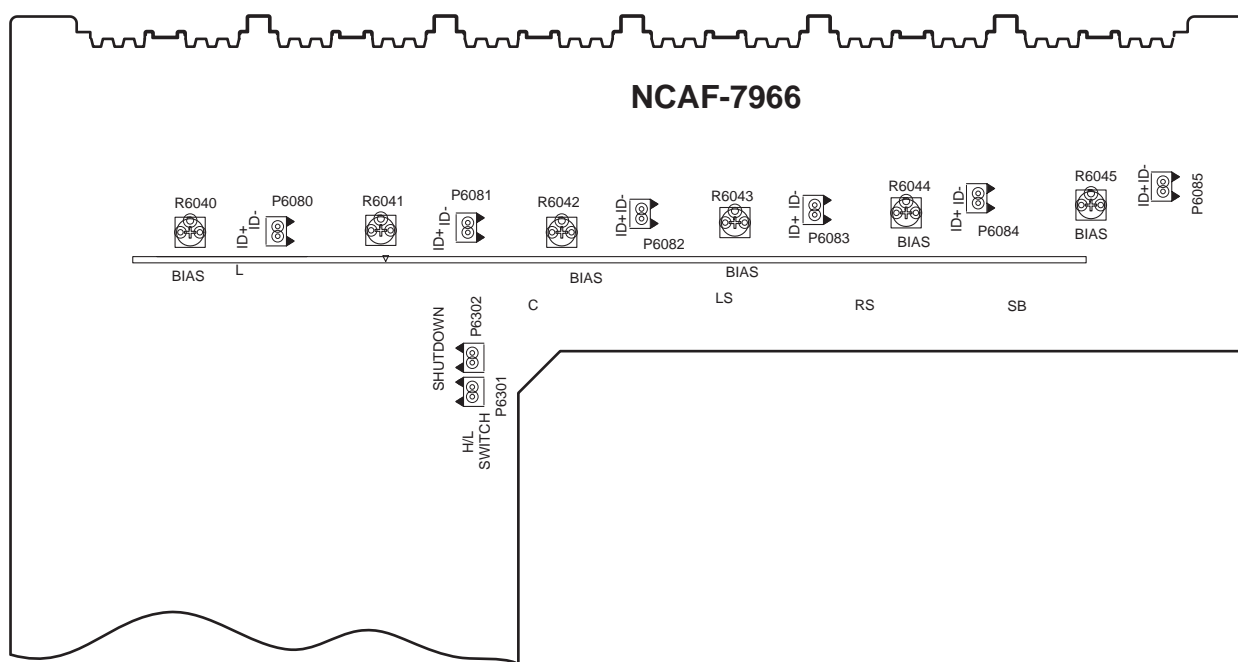

Confirmation of protection circuit

1. Confirmation of operation of speaker relay

Confirm that the speaker relays turn ON approximate. 5 seconds after the power switch is turned ON.

Confirm that the speaker relays turn OFF immediately after the power switch is turned OFF.

2. Confirmation of DC detection circuit

Press and hold down CD button, then press STANDBY/ON button to set the unit to "Test-1" mode.

After "Test-1" on the FL tube light on, press VIDEO 1 button to set the unit to "Test-1-00".

Apply DC 1.5 to 3V to DVD INPUT terminal with no load.

Confirm that the speaker relay turns OFF.

Apply DC -1.5 to -3V to DVD INPUT terminal with no load.

Confirm that the speaker relay turns OFF.

After "Test-1" on the FL tube light on, press REC OUT button two times to set the unit to "Test-1-02".

Apply DC 1.5 to 3V to DVD INPUT terminal with no load. Confirm that the speaker relay turns OFF.

Apply DC -1.5 to -3V to DVD INPUT terminal with no load. Confirm that the speaker relay turns OFF.

Caution: Don't apply DC voltage more than 1 sec..

PACKING PROCEDURES

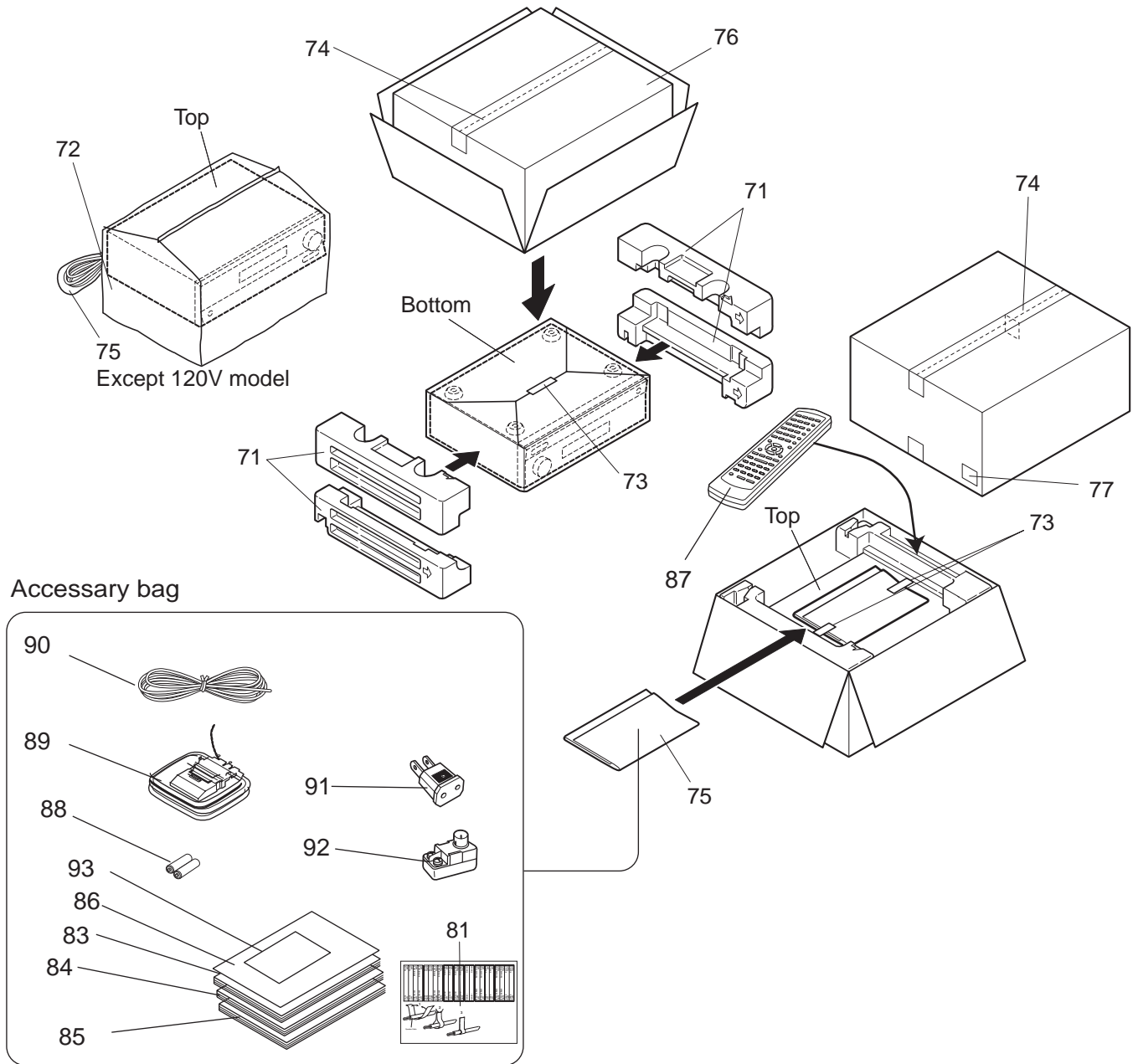

Put the label 81 between page 2 and page 3 of instruction manual E.

EXPLODED VIEW-PARTS LIST			
REF.NO.	PART NO.	DESCRIPTION	
			:Black model only
1	27111271B	Front bracket 	<S>:Silver model only
	27111272B	Front bracket <S>	<G>:Golden model only
	27111273B	Front bracket <G>	<D>:120V model only
2	27212487	Front panel <D/A/C>	<P>:European model only
	27212488	Front panel <T>	<T>:Worldwide model only
	27212489	Front panel <P>	<A>:Australian model only
	27212490	Front panel <S> <P>	<R>:Chinese model only
	27212492	Front panel <G>	<K>:Korean model only
	27212504	Front panel <S> <A/C>	<Q>:Hongkong model only
3	28198778	Facet	<O>:Except 120V model
4	838130088	3TTB+8B,Self-tapping screw	
5	28135244	Badge 	
	28135245	Badge <B/S>	
6	838430088	3TTB+8B(BC),Self-tapping screw	
7	28325907	Knob, volume <D>	
7	28326010	Knob, volume <P/T/A>	
7	28326012	Knob, volume <G>	
7	28326011	Knob, volume <S>	
8	27123094A	Rear panel <D>	
	27123095A	Rear panel <P>	
	27123096A	Rear panel <T/Q>	
	27123097A	Rear panel <R>	
	27123098A	Rear panel <K>	
	27123099A	Rear panel <A>	
10	82143010	3P+10FN(BC),Pan head screw	
11	27191130	Holder, outlet <R>	
12	28325497A	Knob, power 	
	28325499A	Knob, power <G>	
	28325547A	Knob, power <S>	
16	28191957	Clear plate 	
	28191958	Clear plate <G/S>	
21	27100418B	Chassis	
22	27190693A	KGLS-6RT,Holder	
23	27190266	KGLS-12RT,Holder	
24	27190657	KGLS-18RT,Holder	
27	27300750	! Bushing, cord	
31	27160530-1	Heat sink	
32	801606	3SMH10W.SW+15B(CU),Special	
33	830440089	4TTC+8C(BC),Self-tapping screw	
35	27141881	Retainer RT <D>	
36	838430068	3TTB+6B(BC), Self-tapping screw	
38	29363408-1	Label, transformer	
41	28184835	Top cover 	
	28184863	Top cover <G>	
	28184862	Top cover <S>	
42	838430088	3TTB+8B(BC),Self-tapping screw	
	838930088	3TTB+8B(UN),Self-tapping screw	
46	27175319B	Leg	
47	28141494	Cushion	
51	260208	Wire tie	
52	223024	Isolated sheet	
53	29363194	Label <D>	
F6901,F6902	252196 or	!	12A-UL/T-314 or
	252301	!	12A-TUL-250V, Fuse <D>
	252100 or	!	10A-EAK or
	252307	!	10A-TL250V, Fuse <O>
F901	252199	!	10A-UL, Fuse <D/T/Q/R>
F902	252078,	!	5A-SE-EAK,
	252244 or	!	5A-SE-TL250V or
	252278	!	5A-SE-TL250V, Fuse <O>
F903	252164 or	!	5A-UL/T-237 or
	252258	!	5A-T/UL-ST2,Fuse <D>
	252075,	!	2.5A-SE-EAK,
	252241 or	!	2.5A-SE-TL250V or
	252275	!	2.5A-SE-TL250V <O>
REF.NO.	PART NO.	DESCRIPTION	
F9501	252160 or	!	2.5A-UL/T-237 or
	252254	!	2.5A-T/UL-ST2,Fuse <D>
	252075,	!	2.5A-SE-EAK,

	252241 or	!	2.5A-SE-TL250V or	
	252275	!	2.5A-SE-TL250V, Fuse <O>	
P101	2047152522		NCFC7-152522, Flexible cable	
P6931	2045133012		NCFC5-133012, Flexible cable	
P7501	2045081512		NCFC5-081512, Flexible cable	
P7502	2047111512		NCFC7-111512, Flexible cable	
P901	253197HIT or	!	AS-SAA or	
	253198HIT	!	AS-BS, Power supply cord <Q>	
	253233KAW or	!	AS-CEE-2 or	
	253306VOL	!	AS-CEE-2, Power supply cord	
	253307VOL	!	AS-SAA, Power supply cord <A>	
	253332HIT or	!	AS-UC-2 or	
	253333VOL	!	AS-UC-2, Power supply cord <D>	
	253355VOL	!	AS-CCC, Power supply cord <R>	
P902A	25052665	!	NSCT-2P2561, AC outlet <K>	
Q6050~Q6052	2202843 or	*	2SC5242-O or	
	2202842	*	2SC5242-R, Transistor	
Q6053~Q6055	2203663,	*	MN130S-O,	
	2203664,	*	MN130S-Y,	
	2203666,	*	MN130S-P,	
	2202843 or	*	2SC5242-O or	
	2202842	*	2SC5242-R, Transistor	
Q6060~Q6062	2202833 or	*	2SA1962-O or	
	2202832	*	2SA1962-R	
Q6063~Q6065	2203673,	*	MP130S-O,	
	2203674,	*	MP130S-Y,	
	2203676,	*	MP130S-P,	
	2202833 or	*	2SA1962-O or	
	2202832	*	2SA1962-R	
T901	2301692	!	NPT-1469D, Power transformer	
	2301693	!	NPT-1469P, Power transformer	
	2301694	!	NPT-1469DG, Power transformer	
U1	1A972552-1L		NADG-7952-1L, DSP circuit PC	
	1A972552-1M		NADG-7952-1M, DSP circuit PC	
	1A972552-1N		NADG-7952-1N, DSP circuit PC	
	1A972552-1P		NADG-7952-1P, DSP circuit PC	
U2	1A972553-1L		NAVD-7953-1L, Video circuit PC	
	1A972553-1M		NAVD-7953-1M, Video circuit PC	
	1A972553-1N		NAVD-7953-1N, Video circuit PC	
	1A972553-1P		NAVD-7953-1P, Video circuit PC	
U3	1A972554-1L		NAVD-7954-1L, Component video	
	1A972554-1M		NAVD-7954-1M, Component video	
	1A972554-1N		NAVD-7954-1N, Component video	
	1A972554-1P		NAVD-7954-1P, Component video	
U6	1A972560-1L		NADIS-7960-1L, Display circuit PC	
U7	1A972561-1L		NAETC-7961-1L, Headphone	
U8	1A972562-1L		NAETC-7962-1L, Volume PC	
U9	1A972564-1L		NADG-7964-1L, Front opto. Input	
U10	1A972565-1L		NAETC-7965-1L, PC board for	
U11	1A972566-1L		NAAF-7966-1L, Power amplifier	
	1A972566-1M		NAAF-7966-1M, Power amplifier	
U12	1A972567-1L		NAETC-7967-1L, Thermal detector	
	1A972567-1M		NAETC-7967-1M, Thermal	
U13	1A972568-1L		NAAF-7968-1L, Speaker terminal	
	1A972568-1M		NAAF-7968-1M, Speaker terminal	
U14	1A972569-1L		NAETC-7969-1L, PC board for	
	1A972569-1M		NAETC-7969-1M, PC board for	
U15	1A972570-1L		NAETC-7970-1L, Secondary	
	1A972570-1M		NAETC-7970-1M, Secondary	
U16	1A972571-1L		NAETC-7971-1L, PC board for	
	1A972571-1M		NAETC-7971-1M, PC board for	
U17	1A972572-1L		NAETC-7972-1L, PC board for	
	1A972572-1M		NAETC-7972-1M, PC board for	
REF.NO.	PART NO.		DESCRIPTION	
U18	1A972573-1L		NAETC-7973-1L, Thermal detector	
	1A972573-1M		NAETC-7973-1M, Thermal	
U21	1A972574-1L		NAPS-7974-1L, Primary circuit PC	
	1A972574-1M		NAPS-7974-1M, Primary circuit PC	
	1A972574-1N		NAPS-7974-1N, Primary circuit PC	
	1A972574-1P		NAPS-7974-1P, Primary circuit PC	
	1A972574-1Q		NAPS-7974-1Q, Primary circuit PC	
	1A972574-1R		NAPS-7974-1R, Primary circuit PC	

U22	1A972575-1L	NAPS-7975-1L, Constant voltage
	1A972575-1M	NAPS-7975-1M, Constant voltage
	1A972575-1N	NAPS-7975-1N, Constant voltage
	1A972575-1P	NAPS-7975-1P, Constant voltage
	1A972575-1Q	NAPS-7975-1Q, Constant voltage
	1A972575-1R	NAPS-7975-1R, Constant voltage
U23	1A972577-1L	NAETC-7977-1L,Primary terminal
	1A972577-1M	NAETC-7977-1M,Primary terminal
	1A972577-1N	NAETC-7977-1N,Primary terminal
	1A972577-1P	NAETC-7977-1P,Primary terminal
	1A972577-1Q	NAETC-7977-1Q,Primary terminal
	1A972577-1R	NAETC-7977-1R,Primary terminal
U24	1A972581-1L	NAETC-7981-1L, PC board for
	1A972581-1M	NAETC-7981-1M, PC board for
	1A972581-1N	NAETC-7981-1N, PC board for
	1A972581-1P	NAETC-7981-1P, PC board for
	1A972581-1Q	NAETC-7981-1Q, PC board for
	1A972581-1R	NAETC-7981-1R, PC board for
U25	1A972582-1L	NAETC-7982-1L,Main connector
	1A972582-1M	NAETC-7982-1M,Main connector
	1A972582-1N	NAETC-7982-1N,Main connector
	1A972582-1P	NAETC-7982-1P,Main connector
	1A972582-1Q	NAETC-7982-1Q,Main connector
	1A972582-1R	NAETC-7982-1R,Main connector
U26	1A972583-1L	NAAF-7983-1L, Pre-output
	1A972583-1M	NAAF-7983-1M, Pre-output
	1A972583-1N	NAAF-7983-1N, Pre-output
	1A972583-1P	NAAF-7983-1P, Pre-output
	1A972583-1Q	NAAF-7983-1Q, Pre-output
	1A972583-1R	NAAF-7983-1R, Pre-output
U27	1A972584-1L	NAAF-7984-1L,Driver circuit PC
	1A972584-1M	NAAF-7984-1M,Driver circuit PC
	1A972584-1N	NAAF-7984-1N,Driver circuit PC
	1A972584-1P	NAAF-7984-1P,Driver circuit PC
	1A972584-1Q	NAAF-7984-1Q,Driver circuit PC
	1A972584-1R	NAAF-7984-1R,Driver circuit PC
U29	1A972586-1L	NAVD-7986-1L,Front video
	1A972586-1M	NAVD-7986-1M,Front video
	1A972586-1N	NAVD-7986-1N,Front video
	1A972586-1P	NAVD-7986-1P,Front video
	1A972586-1Q	NAVD-7986-1Q,Front video
	1A972586-1R	NAVD-7986-1R,Front video
U30	1A972587-1M	NASW-7987-1M,Power switch PC
	1A972587-1P	NASW-7987-1P,Power switch PC
	1A972587-1Q	NASW-7987-1Q,Power switch PC
	1A972587-1R	NASW-7987-1R,Power switch PC
U36	240138A,	ENG06501QR,
	240134A or	TFCE1U114B or
	240146	FAE385-A02F, Tuner unit <D>
	240139A,	ENG07501QR,
	240135 or	TFCE1E512A or
	240147	FAE485-E02F, Tuner unit <O>
	NOTE: THE COMPONENTS IDENTIFIED BY MARK !	
	ARE CRITICAL FOR RISK OF FIRE AND	
	ELECTRIC SHOCK. REPLACE ONLY WITH	
	PART NUMBER SPECIFIED.	
	CAUTION: Replacement for transistor of mark *, if necessary	
	must be made from the same beta group (hFE) as	
	the original type.	
PACKING-PARTS LIST		
REF.NO.	PART NO.	DESCRIPTION
71	29092052	Pad
72	29100153	1020x720,Polybag
73	29110149	Sello tape
74	29110148	PP tape
75	29100097-1A	350*250,Polybag
76	29054031	Carton box <D>
	29054032	Carton box <A/T/C>
	29054033	Carton box <P>
	29054034	Carton box <S> <A/C>
	29054035	Carton box <S> <P>
	29054036	Carton box <G>

77	29363381	Label EAN <P>	
	29363382	Label EAN <S> <P>	
	29363383	Label EAN <A/T>	
	29363384	Label EAN <S> <A>	
	29363385	Label EAN <G>	
	29363386	Label UPC <D>	
	29363497	Label UPC <S> <C>	
81	29363059A	Label, cable	
83	29343493A	Instruction manual, English	
84	29343495A	Instruction manual,	
	29343497A	Instruction manual Ct/Cs <T/R/Q>	
85	29343496A	Instruction manual U4 <P>	
86	29343494	Instruction manual, digest <D>	
87	24140515	RC-515M,Remote controller	
88	3010054	R6/AA(UM-3), Two batteries	
89	232140	NMA-3057,AM loop antenna	
90	292191	FM antenna	
91	25056005	CV-K-1, Conversion plug <T>	
92	25065462	YAE21-0237, Antenna adapter	
93	29365090A	Warranty card <D>	
		:Black model only	
		<S>:Silver model only	
		<G>:Golden model only	
		<D>:120V model only	
		<P>:European model only	
		<T>:Worldwide model only	
		<A>:Australian model only	
		<R>:Chinese model only	
		<K>:Korean model only	
		<Q>:Hongkong model only	
		<O>:Except 120V model	

PRINTED CIRCUIT BOARD- PARTSLIST

DSP CIRCUIT PC BOARD (NADG-7952-
1L/1M/1N/1P)

NOTE: THE COMPONENTS IDENTIFIED BY MARK
!

CIRCUIT NO.	PART NO.	DESCRIPTION	ARE CRITICAL FOR RISK OF FIRE AND ELECTRIC SHOCK. REPLACE ONLY WITH PART NUMBER SPECIFIED.
Q180	22241845R2	LC72723M <P>	
Q301	22241787R3	TC9274F-020	
Q302	22241761R3	BD3811K1	CAUTION: Replacement for transistor of mark *, if necessary must be made from the same beta group (hFE) as the original type.
Q303~Q306	22241383R2 or 22240581R2	NJM4565M-D or NJM4565M <O>	
Q307,Q308	22241383R2 or 22240581R2	NJM4565M-D or NJM4565M	:Black model only
Q310	22241785R2	BD3812F	<S>:Silver model only
Q311	222780073R2	78L07(SMT)	<G>:Golden model only
Q312	222790073R2	79L07(SMT)	<D>:120V model only
Q700	22241947R3	MB86D42PFV	<P>:European model only
Q7001	22241977R3, 22241948R3 or 22241949R3	MPD703030BGC-029-8EU, MPD70F3030BYGC-8EU or MPD703030BGC-026-8EU	<T>:Worldwide model only <A>:Australian model only <R>:Chinese model only
Q7005	22274000GR2TO	TC74VHCT00AFT	<K>:Korean model only
Q7006	22274004HR2TO	TC74VHCU04FT	<Q>:Hongkong model only
Q701	22274074ER2TO or 22274074IR2TI	TC74VHC74FT or SN74AHC74PWR	<O>:Except 120V model
Q703	22241847R3	MB86344BPFV	
Q704	22240935R2	TC7WU04FU	
Q705,Q706	22241887R2 or 22241612R2	CY7C1019CV33-15VCT or CY7C1019BV33-15VCT	
Q707	22240935R2	TC7WU04FU	
Q751	22274074ER2TO or 22274074IR2TI	TC74VHC74FT or SN74AHC74PWR	
Q800	22241944R3	CS42518-CQ	
Q801~Q804	22241383R2 or 22240581R2	NJM4565M-D or NJM4565M	
Q9501	222780125	78M12HF	
Q9502	222790125	79M12HF	
Q9506	222780054NEC	MPC7805HF	
Q9508	22278028DR2JR	NJM2391DL1-285	
Q9509	22278033BR2JR	NJU7200U33	
Q9510	22278033DR2NE or 22278033DR2JR	MPC2933T or NJM2391DL1-33	
Q9512	222790055	79M05FA	
Q9513	222780053R2JR	NJM78L05UA	
Transistors			
Q101	2216175R2 or 2213145R2	KTC3875-GR or 2SC2712-GR <P>	
Q400,Q401	2214530R2 or 2216220R2	RN2402 or KRA102S	
Q403,Q404	2214490R2 or 2216210R2 2216210R2	RN1404 or KRC104S KRC104S	

Q7002	2214490R2 or 2216210R2	RN1404 or KRC104S
Q9507	2202314 or 2202315	2SA1726-Y or 2SA1726-P

Diodes

D300,D301	223234R2 or 223269R2	1SS352 or 1SS355
D7001~D7003	223234R2 or 223269R2	1SS352 or 1SS355
D7004	224660624R2, 224550620R2 or 224490620R2	HZU6.2B, UDZS6.2B or UDZ6.2B
D7005	223234R2 or 223269R2	1SS352 or 1SS355
D800~D807	223234R2 or 223269R2	1SS352 or 1SS355

CIRCUIT NO.	PART NO.	DESCRIPTION
--------------------	-----------------	--------------------

Oscillators

X180	3010332R2	HC-49/U03C4.332MHz <P>
X700	3010368R2	XTL-13.5M,Crystal
X7001	3010329R2	CSTCV16.00MXJ0C,Ceramic
X701	3010324R2	CSTCV12.2MTJ0C4,Ceramic

Coils and Filters

L708,L751	231237M022R2 or 233533M022R2	NCH-1471 or NCH-1587-022M
L180	231237K220R2 or 233533K220R2	NCH-1477 or NCH-1587-220K <P>
L7001,L701	231237K220R2 or	NCH-1477 or
L704	233533K220R2	NCH-1587-220K
L705~L707	230958R1	BK1608LM182-T
L753	231237K470R2 or 233533K470R2	NCH-1479 or NCH-1587-470K
L800,L801	231237M022R2 or	NCH-1471 or
L803	233533M022R2	NCH-1587-022M
R7095,R7096	230958R1	BK1608LM182-T

Capacitors

C101,C102	394680337 or 394780337	CE04W50V-3.3M(VR) or CE04W50V3.3M(SC),Elect.
C116	393344707	CE04W16V-47M(VX),Elect.
C180,C186	394641007 or 394741007	CE04W16V-10M(VR) or CE04W16V10M(SC),Elect. <P>
C308,C309	373022214R2	ECHU50V-221J,Plastic
C338,C339	373022724R2	ECHU50V-272J,Plastic
C340	373021224R2	ECHU50V-122J,Plastic
C341	373022724R2	ECHU50V-272J,Plastic
C342,C343	373021224R2	ECHU50V-122J,Plastic
C350~C353	394642217 or 394742217	CE04W16V-220M(VR) or CE04W16V220M(SC),Elevt.
C358~C363	393341007	CE04W16V-10M(VX),Elect.
C366,C367	373023324R2	ECHU50V-332J,Plastic
C368,C369	373045634R2	ECHU16V-563J,Plastic

C373~C376	393341007	CE04W16V-10M(VX),Elect.
C377,C379	393382207	CE04W50V-22M(VX),Elect.
C378	393341007	CE04W16V-10M(VX),Elect.
C380~C383	393341007	CE04W16V-10M(VX),Elect.
C384	393382207	CE04W50V-22M(VX),Elect.
C400	393341007	CE04W16V-10M(VX),Elect.
C405,C406	393341007	CE04W16V-10M(VX),Elect.
C410,C411	394641007 or 394741007	CE04W16V-10M(VR) or CE04W16V10M(SC),Elect.
C7002,C7004	394680107 or 394780107	CE04W50V-1M(VR) or CE04W50V1.0M(SC),Elect.
C7009 ,C719	394621017 or	CE04W6.3V-100M(VR) or
C720,C721	394721017	CE04W6.3V100M(SC),Elect.
C7010	394624707 or 394624707	CE04W6.3V-47M(VR) or CE04W6.3V-47M(VR),Elect.
C764~C766	394621017 or	CE04W6.3V-100M(VR) or
C807,C816	394721017	CE04W6.3V100M(SC),Elect.
C802,C803	373022224R2	ECHU50V-222J,Plastic
C804	394680107 or 394780107	CE04W50V-1M(VR) or CE04W50V1.0M(SC),Elect.
C809,C813	394623317 or 394723317	CE04W6.3V-330M(VR) or CE04W6.3V330M(SC),Elect.
C819~C822	373024724R2	ECHU50V-472J,Plastic
C823	373043334R2	ECHU16V-333J,Plastic
C824~C826	373024724R2	ECHU50V-472J,Plastic <D>
C835,C836	373041534R2	ECHU16V-153J,Plastic
C843,C844	394642217 or	CE04W16V-220M(VR) or
C9501	394742217	CE04W16V220M(SC),Elect.
C9503	375521044	MMT50V-104J,Plastic
C9508	394664707 or 394764707	CE04W35V-47M(VR) or CE04W35V47M(SC),Elect.
CIRCUIT NO.	PART NO.	DESCRIPTION
	Capacitors	
C9509,C9510	394542217	CE04W16V-220M(VZ),Elect.
C9511	394644707 or 394744707	CE04W16V-47M(VR) or CE04W16V47M(SC),Elect.
C9514,C9515	394621017 or 394721017	CE04W6.3V-100M(VR) or CE04W6.3V100M(SC),Elect.
C9520,C9522	394522217	CE04W6.3V-220M(VZ)
C9527	394641007 or 394741007	CE04W16V-10M(VR) or CE04W16V10M(SC),Elect.
	Resistors	
R782	43474056004R1 or	RM0KJ560X04 or
R787~R791	43474456004R1	RM4KJ560X4,Array
R9501	442621204	RS1WBJ-12,Metal oxide
R9502	441622204	RS1WBJ-22,Metal oxide
R9505	441623304	RS1WBJ-33,Metal oxide
R9507	441720394	RS2WBJ-3.9,Metal oxide
R9510	441720154	RS2WBJ-1.5,Metal oxide
	Terminals	
P300	25045303 or	NPJ-4PDBL162 or

	25045575	NPJ-4PDRW389
P301,P302	25045300 or	NPJ-6PDBL159 or
	25045571	NPJ-6PDRW386
P303	25045697	NPJ-6PWRLGGP493
	Sockets	
JL9501B	25050269	NSCT-5P97
P101A	25052211 or	NSCT-15P2108 or
	25051822	NSCT-15P1609
P6931B	25052579R2	NSCT-13P2476
	Plugs	
P304	25055133	NPLG-3P117
P7503B	25055624	NPLG-3P586
P7701	25055704	NPLG-8P660
	Heat sink	
Q9501B	27160500	RAD-165
	Isolated sheet	
Q9507B	223026	ISO SHEET
	Isolated washer	
Q9507C	223032	TO-66(1)
	Pan head screws	
D9005B,Q9501A	82143010	3P+10FN(BC)
Q9506A,Q9507A	82143010	3P+10FN(BC)

**VIDEO CIRCUIT PC BOARD (NADG-7953-11 /1M/1N/1P)
CIRCUIT NO.**

CIRCUIT NO.	PART NO.	DESCRIPTION
	ICs	
Q201~Q203	22241946R2	NJM2595M
Q204	22241779	LC74763-9836
Q205	22241221R2	TC9164AF
Q206	22241849R2	MM1512
Q211	222740046R2	74HCU04F
	Photo couplers	
Q207	24120080	PC817X
U201,U202	24120101	TORX179L
U203	24120102	TOTX179L
	Transistors	
Q208~Q210	2215510R2	RN1443
Q212~Q217	2215510R2	RN1443
Q218~Q220	2216185R2 or	KTA1504-GR or
	2214375R2	2SA1162-GR
Q221	2213145R2	2SC2712-GR
Q222,Q223	2216031R2	RN1444-A
Q224	2214550R2 or	RN2404 or
	2216220R2	KRA102S

CIRCUIT NO.	PART NO.	DESCRIPTION
	Diodes	
D201~D203	223234R2 or	1SS352 or
	223269R2	1SS355
	Oscillators	

X201	3010363	HC-49/U0314.318M,Crystal
X202	3010364	HC-49/U0317.734M,Crystal <O>
Coils and Filters		
L201~L203	231237K022R2 or	NCH-1471 or
L205,L208	233533K022R2	NCH-1587-022K
L204,L207	231292J056R2	NCH-1572
L206	231292J056R2	NCH-1572 <O>
L210	231237K022R2 or 233533K022R2	NCH-1471 or NCH-1587-022K
Capacitors		
C203,C232	394644707 or 394744707	CE04W16V-47M(VR) or CE04W16V47M(SC),Elect.
C219~C226	394641007 or 394741007	CE04W16V-10M(VR) or CE04W16V10M(SC),Elect.
C237~C239	394621017 or	CE04W6.3V-100M(VR) or
C249,C250	394721017	CE04W6.3V100M(SC),Elect.
C245,C248	394624717 or 394724717	CE04W6.3V-470M(VR) or CE04W6.3V470M(SC),Elect.
C251	394621017 or	CE04W6.3V-100M(VR) or
C256,C257	394721017	CE04W6.3V100M(SC),Elect.
C255	394642207 or 394742207	CE04W16V-22M(VR) or CE04W16V22M(SC),Elect.
C259	394680107 or 394780107	CE04W50V-1M(VR) or CE04W50V1.0M(SC),Elect.
C269	394680107 or 394780107	CE04W50V-1M(VR) or CE04W50V1.0M(SC),Elect.
C270	394683397	CE04W50V-0.33M(VR),Elect.
C273	375522234	MMT50V-223J,Plastic
C274	394680107 394780107	CE04W50V-1M(VR) or CE04W50V1.0M(SC),Elect.
C275	374726824	ECQ-B50V-682J,Plastic
C276	394644707 or 394744707	CE04W16V-47M(VR) or CE04W16V47M(SC)
C280,C282	394621017 or	CE04W6.3V-100M(VR) or
C288	394721017	CE04W6.3V100M(SC),Elect.
C281	394684797 or 394784797	CE04W50V-0.47M(VR) or CE04W50V0.47M(SC),Elect.
C283	375524744	MMT50V-474J,Plastic
C291,C292	394641007 or 394741007	CE04W16V-10M(VR) or CE04W16V10M(SC),Elect.
C293~C296	394624717 or 394724717	CE04W6.3V-470M(VR) or CE04W6.3V470M(SC),Elect.
Terminals		
P201	25045473	NPJ-1PDBL291
P202	25045727	NPJ-15PDBY515
P204	25045729	NPJ-10PDBY517
P205	25045729	NPJ-10PDBY517
P206	25045647	HSJ1002-01-1020
Sockets		
P207B	25051235	NSCT-10P1025
P208B	25051527	NSCT-16P1314

P209A	Plug 25055236	NPLG-5P220
-------	-------------------------	------------

**COMPONENT VIDEO PC BOARD
(NADG-7954-11 /1M/1N/1P)
CIRCUIT NO.**

CIRCUIT NO.	PART NO.	DESCRIPTION
ICs		
Q2255	22241383R2 or 22240581R2	NJM4565M-D or NJM4565M
Transistors		
Q2201	2214460R2 or 2216330R2	RN1401 or KRC101S
Q2257	2216220R2 or	KRA102S or
Q2257 or	2214530R2	RN2402
Q2271,Q2272	2215410R2	RN1441
Diodes		
D2201	223234R2 or 223269R2	1SS352 or 1SS355
Capacitors		
C2251,C2252	393380227	CE04W50V-2.2M(VX),Elect.
C2263,C2264	393341007	CE04W16V-10M(VX),Elect.
C2268,C2269	394641007 or	CE04W16V-10M(VR) or
C2268 or	394741007	CE04W16V10M(SC),Elect.
Relays		
RL2201,RL2202	25065645	NPL-2P1A-DC4.5-169
Terminals		
P2203	25045731	NPJ-9PDGLR519
P2209	25045333	NPJ-2PDBL185
P2211	25045696	LGY2502-0200C
Sockets		
P2201B	25051230	NSCT-5P1020
P2210B	25051232	NSCT-7P1022

**DISPLAY CIRCUIT PC BOARD (NADIS-
7960-1L)
CIRCUIT NO.**

CIRCUIT NO.	PART NO.	DESCRIPTION
FL tube		
Q7501	212229	HNA-16MM39T
ICs		
Q7502	22241971R3	MPD780232GC-085-8BT
Remote sensor		
U7501	241348	RPM7138-H9
Transistors		
Q7503	2216175R2 or 2213145R2	KTC3875-GR or 2SC2712-GR
Q7504	2216230R2 or	KRA103S or

	2214540R2	RN2403
Q7505	2216190R2 or 2214470R2	KRC102S or RN1402
Q7581	2216190R2 or 2214470R2	KRC102S or RN1402
Q7583	2216190R2 or 2214470R2	KRC102S or RN1402
Q7701	2216190R2 or 2214470R2	KRC102S or RN1402
	Diodes	
D7501	224490820R2, 224550820R2 or 224660824R2	UDZ8.2B, UDZS8.2B or HZU8.2B
D7502	224490510R2, 224550510R2 or 224660514R2	UDZ5.1B, UDZS5.1B or HZU5.1B
D7503	223234R2 or 223269R2	1SS352 or 1SS355
D7505	224490270R2, 224660274R2 or 224550270R2	UDZ2.7B, HZU2.7B or UDZS 2.7B
D7506~D7508 D7701,D7702	223234R2 or 223269R2	1SS352 or 1SS355
D7581	225290	SEL4110R
D7583	225291D	SEL4910D-D
CIRCUIT NO.	PART NO.	DESCRIPTION
	Oscillator	
X7501	3010242	CST5.00MGW,Ceramic
	Coils	
L7504	231237M022R2	NCH-1471
L7505	231237M022R2	NCH-1471
	Capacitors	
C7502	394684707 or 394784707	CE04W50V-47M(VR) or CE04W50V47M(SC),Elect.
C7514,C7705	394621017 or 394721017	CE04W6.3V-100M(VR) or CE04W6.3V100M(SC),Elect.
C7521,C7540	394622217 or 394722217	CE04W6.3V-220M(VR) or CE04W6.3V220M(SC),Elect.
C7523,C7550	375524744	MMT50V-474J,Plastic
C7524	3000120 or 3000121	FMC0H104Z or SCDA5R51U4A,Super tor back- up
	Resistors	
R7591,R7593	49163104415	RM1/10IJ-100K*15,Array
R7592	49163104412	RM1/10IJ-100K*12,Array
	Relay	
RL7701	25065610 or 25065645	NRL-2P1A-DC4.5-156 or NPL-2P1A-DC4.5-169
	Switches	
S7611~S7618	25035699 or	NPS-111-S662 or
S7621~S7624	25035714	NPS-111-S677
S7619	25035699 or	NPS-111-S662 or

S7619	25035714	NPS-111-S677
S7625	25035699 or	NPS-111-S662 or
S7625	25035714	NPS-111-S677
S7626~S7628	25035699 or	NPS-111-S662 or
S7631~S7638	25035714	NPS-111-S677
S7641~S7643	25035699 or	NPS-111-S662 or
	25035714	NPS-111-S677
S7645~S7647	25035699 or	NPS-111-S662 or
	25035714	NPS-111-S677

Sockets

JL7501A	25051087	NSCT-3P874
JL7502A	25051089	NSCT-5P876
P7501A	25052345	NSCT-8P2242
P7502A	25052244	NSCT-11P2141

Plugs

P7504	25056056	NPLG-8P1006
-------	----------	-------------

Holders

Q7501A	27190989A	(FL)
--------	-----------	------

**HEADPHONE TERMINAL PC BOARD
(NAETC-7961-1L)**

CIRCUIT NO.	PART NO.	DESCRIPTION
	Coils	
L7701	231237M022R2	NCH-1471
L7703,L7704	231237M022R2	NCH-1471
	Capacitors	
C7703	374722215	ECQ-B50V-221K,Plastic
	Terminal	
P7705	25045724	YKB21-5005
	Socket	
JL7502B	25051089	NSCT-5P876

VOLUME PC BOARD (NAETC-7962-1L)

CIRCUIT NO.	PART NO.	DESCRIPTION
	Rotary encoder	
S7501	25065627	EC12E2425
	Sockets	
JL7501B	25051087	NSCT-3P874

**FRONT OPTICAL INPUT PC BOARD
(NADG-7964-1L)**

CIRCUIT NO.	PART NO.	DESCRIPTION
	Photo coupler	
U2601	24120108	GP1FA513RZ
	Coil	
L2601	231237M022R2	NCH-1471
	Capacitor	
C2601	394621017 or 394721017	CE04W6.3V-100M(VR) or CE04W6.3V100M(SC),Elect.
	Resistor	
R2601	435032214R1	RN72K1J-221JE

	Socket	
JL7503A	25051087	NSCT-3P874

POWER AMPLIFIER PC BOARD (NAAF-7966-11 /1M)

CIRCUIT NO.	PART NO.	DESCRIPTION
	Transistors	
Q6010~Q6015	2213284 or	2SC1740S-R or
Q6020~Q6025	2213285	2SC1740S-S
Q6030~Q6032	2203010	2SC5171
Q6033~Q6035	2203434 or	KTD2061-Y or
	2203010	2SC5171
Q6040~Q6042	2203000	2SA1930
Q6043~Q6045	2203424 or	KTB1369-Y or
	2203000	2SA1930
Q6070~Q6075	2215896,	KTC3200-BL,
	2215895,	KTC3200-GR,
	2210755,	2SC1775A-E,
	2210756,	2SC1775A-F,
	2211733 or	2SC1845-E or
	2211732	2SC1845-F
Q6303,Q6304	2215995,	KTA1267-GR,
	2213354 or	2SA933S-R or
	2213355	2SA933S-S
Q6601~Q6603	2215864,	KTC3199-GR,
Q6901	2213284,	2SC1740S-R,
	2213285 or	2SC1740S-S or
	2212115	2SC2458-GR
Q6701,Q6702	2215896,	KTC3200-BL,
	2215895,	KTC3200-GR,
	2210755,	2SC1775A-E,
	2210756,	2SC1775A-F,
	2211733 or	2SC1845-E or
	2211732	2SC1845-F
Q6703	2215885,	KTA1268-GR,
	2215886,	KTA1268-BL,
	2211793 or	2SA992-E or
	2211792	2SA992-F
	Diodes	
D6000~D6005	223163,	1SS133,
D6010~D6015	223205 or	1SS270A or
D6306,D6307	223222	WG713A
D6701,D6702	223163,	1SS133,
D6906	223205 or	1SS270A or
	223222	WG713A
D6703,D6704	224470512	MTZJ5.1B
D6707	224470512	MTZJ5.1B
D6904,D6905	22380337	D10XB60H
	Capacitors	
C604~C6045	394684707	CE04W50V-47M(VR),Elect.
C6050~C6055	374721034	ECQ-B50V-103J,Plastic
C6230~C6235	374724734	ECQ-V50V-473J,Plastic

C6701,C6706	394621017 or 394721017	CE04W6.3V-100M(VR) or CE04W6.3V100M(SC),Elect.
C6704	394680107 or 394780107	CE04W50V-1M(VR) or CE04W50V1.0M(SC),Elect.
CIRCUIT NO.	PART NO.	DESCRIPTION
	Capacitors	
C6708	374722224	ECQ-B50V-222J,Plastic
C6901,C6902	3504313	CE69W63V-12000M,Elect.
C6904,C6905	374733344	ECQ-V100-334J,Plastic
C6906,C6907	374721044	ECQ-V50V-104J,Plastic
	Resistors	
R6040~R6045	5210258	N06HR1KBC,Trimming
R6070~R6075	415471214	R25J-120,NF carbon
R6080~R6085	415470224	R25J-2.2,NF carbon
R6090~R6095	415470224	R25J-2.2,NF carbon
R6100~R6105	4000201, 4000132 or 4500245	RF-5EGKR22, RGC55 0.22 or BPR55FK0.22,Metal plate
R6230~R6235	453630824	RNU1WCJ-8.2,Metal
R6750,R6751	443523914	RS1/2WBJ-390,Metal oxide
	Relays	
RL6901	25065584, 25065516 or 25065588	NRL-1P10A-DC12-140, NRL-1P10A-DC12-097 or NRL-1P10A-DC12-143
RL6902	25065584 or 25065516	NRL-1P10A-DC12-140 or NRL-1P10A-DC12-097
	Fuse holders	
F6901A,F6901B	25052133 250113	NSCT-1P2031 <O> SN5051 <D>
F6902A,F6902B	25052133 250113	NSCT-1P2031 <O> SN5051 <D>
	Sockets	
JL6402A	25051088	NSCT-4P875
JL6803A,JL6804A	25051110	NSCT-6P897
JL6805A	25051108	NSCT-4P895
JL6951A,JL6952A	25051109	NSCT-5P896
JL6953A	25051092	NSCT-8P879
P6931A	25052313	NSCT-13P2210
	Plugs	
P6000A~P6004A	25056010	NPLG-5P0960
P6005A	25056017	NPLG-12P0967
P6080~P6085	25055038	NPLG-2P29
P6301,P6302	25055038	NPLG-2P29
P931A	25055701	NPLG-5P657
	Label	
F6901C	29362801	T10AL250V <A>
	Heat sink	
D6904A	27160499	RAD-164
	Bar	
P6011A	27141860	(BUS-D)
	Pan head screws	

Q9512A	82143010	3P+10FN(BC)
D6904B	82143010	3P+10FN(BC)

**THERMAL DETECTOR PC BOARD
(NAFTC-7967-11 /1M)
CIRCUIT NO.**

CIRCUIT NO.	PART NO.	DESCRIPTION
	Thermistors	
R6380	4000153	PTH9M04BF222TS2F333
R6381	4000150	PTH9M04BC222TS2F333 <O>
R6381	4000218	PTH9M04BE471Q2N34BU (9U) <D>
	Socket	
JL6402B	25051088	NSCT-4P875

**SPEAKER TERMINAL PC BOARD
(NAFTC-7968-1L/1M)
CIRCUIT NO.**

CIRCUIT NO.	PART NO.	DESCRIPTION
	Diodes	
D6600,D6601	223163,	1SS133,
D6604	223205 or 223222	1SS270A or WG713A
	Coils	
L6800~L6805	231176S	S-1.3C
	Capacitors	
C6840~C6847	374721034	ECQ-B50V-103J,Plastic
C6850~C6857	374721024	ECQ-B50V-102J,Plastic
	Resistors	
RL6600,RL6601	25065563,	NRL-2P5A-DC24-129,
RL6603,RL6604	25065586, 25065517 or 25065636	NRL-2P5A-DC24-142, NRL-2P5A-DC24-098 or NRL-2P5A-DC24-164
	Terminals	
P6803	25060333	NTM-8PDMN264 <D>
P6803	25060329	NTM-8PDMN260 <O>
	Sockets	
JL6803B,JL6804B	25050283	NSCT-6P111
JL6805B	25050281	NSCT-4P109

**SECONDARY TERMINAL PC BOARD
(NAFTC-7970-11 /1M)
CIRCUIT NO.**

CIRCUIT NO.	PART NO.	DESCRIPTION
	Capacitors	
C9591	374721044	ECQ-V50V-104J,Plastic
	Resistors	
R9591,R9592	453530104	RNU1/2WCJ-1,Metal
R9594	453530104	RNU1/2WCJ-2.7 <D>
R9594	453530104	RNU1/2WCJ-4.7 <O>
	Fuse holders	

F9501A,F9501B	25052133	NSCT-1P2031
	Sockets	
JL6951B,JL6952B	25051109	NSCT-5P896
JL9502A	25051111	NSCT-7P898
	Label	
F9501C	29361747	T2.5AL250V <O>

PRIMARY CIRCUIT PC BOARD (NAPS-7974-11 /1M/1N/1P/1Q/1R)

CIRCUIT NO.	PART NO.	DESCRIPTION
	Transistors	
Q921	2215864, 2213284, 2213285 or 2212115	KTC3199-GR, 2SC1740S-R, 2SC1740S-S or 2SC2458-GR
	Diodes	
D921~D924	22380260 or 22380035	RL1N4003 or GP104003E
D925	223163 or 223205	1SS133 or 1SS270A,Diode
	Power transformer	
T902	2301381	NPT-1358D <D>
T902	2301382	NPT-1358P <P/A>
T902	2301383	NPT-1358DG <T/R/Q/K>
	Capacitors	
C901	3500196S	RE275V-103M,IS
C922	394662217	CE04W35V-220M(VR),Elect.
C923	374721024	ECQ-B50V-102J,Plastic
	Resistors	
R924	443526804	RS1/2WBJ-68,Metal
	Relays	
RL901	25065584 or 25065516	NRL-1P10A-DC12-140 or NRL-1P10A-DC12-097
	Switch	
S902	25065437	NSS-22157P <T/Q/R>
CIRCUIT NO.	PART NO.	DESCRIPTION
	Fuse holders	
F901A,F901B	25052133	NSCT-1P2031 <D/T/Q/R>
F902A,F902B	25052133	NSCT-1P2031 <O>
F903A,F903B	25052133	NSCT-1P2031
	Terminal	
P902	25051126 25051125 25052115 25052664 25051126	NSCT-4P913 <D> NSCT-4P912 <P/T/Q> NSCT-2P2013 <A> NSCT-2P2560 <R> NSCT-4P913 <J>
	Sockets	
P931A	25051230	NSCT-5P1020
	Plugs	
P901A	25055675 or 25056028	NPLG-2P631 or NPLG-2P0978
	Labels	

F901E 29362325 12A/250V <J>

CONSTANT VOLTAGE CIRCUIT PC BOARD (NAPS-7975-CIRCUIT NO.

CIRCUIT NO.	PART NO.	DESCRIPTION
	IC	
Q9001	222780565JRC	NJM78M56FA
	Transistor	
Q9002	2215975 or 2211455	KTA1266-GR or 2SA1015-GR
	Diodes	
D9001~D9004	22380260 or	RL1N4003 or
D9009~D9011	22380035	GP104003E
D9005	22380271, 22380285 or 22380022	D3SBA20, RS403M or RBV402
D9012	224472704	MTZJ27D
D9013	22380260 or 22380035	RL1N4003 or GP104003E
	Capacitors	
C9001,C9002	375523344	MMT50V-334J,Plastic
C9003	394661027S	CE04W35V-1000M(VR),Elect.
C9004	394664717	CE04W35V-470M(VR),Elect.
C9005	375523344	MMT50V-334J,Plastic
C9009	394662217	CE04W35V-220M(VR),Elect.
C9010	394644727S	CE04W16V-4700M(VR),Elect.
C9011	394651027S	CE04W25V-1000M(VR),Elect.
C9013	394641007	CE04W16V-10M(VR),Elect.
C9014	394674717S	CE04W63V-470M(VR),Elect.
C9017	374721024	ECQ-B50V-102J,Plastic
	Resistors	
R9001	443523304	RS1/2WBJ-33,Metal oxide
R9002	443522204	RS1/2WBJ-22,Metal oxide
R9006	453530474	RNU1/2WCJ-4.7,Metal
	Sockets	
JL9501A	25051109	NSCT-5P896
JL9502B	25050271	NSCT-7P99
P7502B	25052207	NSCT-11P2104
	Plug	
JL6953B	25055629	NPLG-8P591
	Heat sink	
D9005A	27160211	RAD-68
	Pan head screw	
D6905B	82143010	3P+10FN(BC)

MAIN CONNECTOR PC BOARD (NAE1C 7982-11 (1M/1N/1P/1Q/1R) CIRCUIT NO.

CIRCUIT NO.	PART NO.	DESCRIPTION
-------------	----------	-------------

	Transistors	
Q2904,Q2905	2215960 or 2213290	KRC102M or DTC114ES
Q2907	2215960 or 2213290	KRC102M or DTC114ES
Q2909	2212855 or 2212853	2SB1068-U or 2SB1068-K
	Capacitors	
C2903	394621017	CE04W6.3V-100M(VR),Elect.
C2904	374722234	ECQ-B50V-223J,Plastic
	Thermistor	
R2905	4000195	RXE030
	Sockets	
P105B,P107B	25051241	NSCT-20P1031
	Plugs	
P207A	25055706	NPLG-10P662
P208A	25055805	NPLG-16P761
P2201A	25055701	NPLG-5P657
P2210A	25055703	NPLG-7P659

DRIVER CIRCUIT PC BOARD (NAAF-7984-11 /1M/1N/1P/1Q/1R)

CIRCUIT NO.	PART NO.	DESCRIPTION
	Transistors	
Q5000~Q5002	2211733 or 2211732	2SC1845-E or 2SC1845-F
Q5003~Q5005	2215896, 2210755, 2210756 or 2211733	KTC3200-BL, 2SC1775A-E, 2SC1775A-F or 2SC1845-E
Q5010~Q5012	2211733 or 2211732	2SC1845-E or 2SC1845-F
Q5013~Q5015	2215896, 2210755, 2210756 or 2211733	KTC3200-BL, 2SC1775A-E, 2SC1775A-F or 2SC1845-E
Q5020~Q5022	2211793 or 2211792	2SA992-E or 2SA992-F
Q5030~Q5032	2202094 or 2202093	2SA1360-Y or 2SA1360-O
Q5033~Q5035	2215844, 2215843, 2211354 or 2211353	KTA1024-Y, KTA1024-O, 2SA949-Y or 2SA949-O
Q5040~Q5042	2202104 or 2202103	2SC3423-Y or 2SC3423-O
Q5043~Q5045	2215854, 2215853, 2211634 or 2211633	KTC3206-Y, KTC3206-O, 2SC2229-Y or 2SC2229-O
Q5050~Q5052	2212115, 2213284 or	2SC2458-GR, 2SC1740S-R or

Q5053~Q5055	2213285 2215864, 2213284, 2213285 or 2212115	2SC1740S-S KTC3199-GR, 2SC1740S-R, 2SC1740S-S or 2SC2458-GR
Q5060~Q5065 Q5070~Q5075 Q5067,Q5077	2213631 or 2213632 2213631 or 2213632	RN1241-A or RN1241-B RN1241-A or RN1241-B
Q5801	2215864, 2213284, 2213285 or 2212115	KTC3199-GR, 2SC1740S-R, 2SC1740S-S or 2SC2458-GR
CIRCUIT NO.	PART NO.	DESCRIPTION
	Diodes	
D5000~D5005 D5801	224470562 223163 or 223205	MTZJ5.6B 1SS133 or 1SS270A
D5802	224470512	MTZJ5.1B
	Capacitors	
C5000~C5005 C5010~C5015 C5020~C5025 C5030~C5035 C5040~C5045 C5050~C5055 C5100~C5105 C5110~C5115 C5120~C5125 C5127	374721015 393381007 394681007 374721015 393342217 394684707 394671007 394671007 393381007 393381007	ECQ-B50V-101K,Plastic CE04W50V-10M(VX),Elect. CE04W50V-10M(VR),Elect. ECQ-B50V-101K,Plastic <O> CE04W16V-220M(VX),Elect. CE04W50V-47M(VR),Elect. CE04W63V-10M(VR),Elect. CE04W63V-10M(VR),Elect. CE04W50V-10M(VX),Elect. CE04W50V-10M(VX),Elect.
	Resistors	
D5803 R5120~R5122 R5160~R5165 R5170~R5175 R5180~R5185 R5190~R5195	417343304 415474714 415471214 415471214 415471004 415471004	R16J-33,Carbon R25J-470,NF carbon R25J-120,NF carbon R25J-120,NF carbon R25J-10,NF carbon R25J-10,NF carbon
	Relay	
RL5801	25065645	NPL-2P1A-DC4.5-169
	Sockets	
P6000B~P6004B P6005B	25052288 25052295	NSCT-5P2185 NSCT-12P2192
	Plugs	
JL5802B P308A	25055626 25055156	NPLG-5P588 NPLG-12P140
	Bar	
P6011B	27141859	(BUS-U)

**PRE-OUTPUT TERMINAL PC BOARD
(NAAF-7985-11 (1M/1N/1P/1Q/1R))**

CIRCUIT NO.	PART NO.	DESCRIPTION
	Capacitors	

C6883,C6884	374721024	ECQ-B50V-102J,Plastic
	Terminal	
P6813	25045720	NPJ-1PDP510
	Socket	
JL5802C	25051089	NSCT-5P876

FRONT VIDEO PC BOARD (NAVD-7986-1L/1M/1N/1P/1Q/1R)

CIRCUIT NO.	PART NO.	DESCRIPTION
	Capacitors	
C2501,C2502	374724714	ECQ-B50V-471J,Plastic
C2503,C2504	374721024	ECQ-B50V-102J,Plastic
	Terminal	
P2503	25045680	NPJ-7PDB477
	Sockets	
P209B	2009990792UL	NSAS-10P1159
P2501B	2009990513UL	NSAS-6P0675

**POWER SWITCH PC BOARD (NASW-7987-1M/1P/1Q/1R)
Except 120V/Australian models**

CIRCUIT NO.	PART NO.	DESCRIPTION
	Capacitors	
C902	3300030	DE1307E472M-KH
	Switches	
S906	25035702	NPS-121-L665P

ONKYO CORPORATION

Sales & Product Planning Div. : 2-1, Nisshin-cho, Neyagawa-shi, OSAKA 572-8540, JAPAN
Tel: 072-831-8111 Fax: 072-833-5222

ONKYO U.S.A. CORPORATION

18 Park Way, Upper Saddle River, N.J. 07458, U.S.A.
Tel: 201-785-2600 Fax: 201-785-2650 E-mail: onkyo@onkyousa.com

ONKYO EUROPE ELECTRONICS GmbH

Liegnitzerstrasse 6, 82194 Grobenzell, GERMANY
Tel: +49-8142-4401-0 Fax: +49-8142-4401-555 E-mail: info@onkyo.de

ONKYO CHINA LIMITED

Units 2102-2107, Metroplaza Tower I, 223 Hing Fong Road, Kwai Chung,
N.T., HONG KONG Tel: 852-2429-3118 Fax: 852-2428-9039

