

**BLOCK DIAGRAM-1
AUDIO SECTION**

1

2

3

4

5

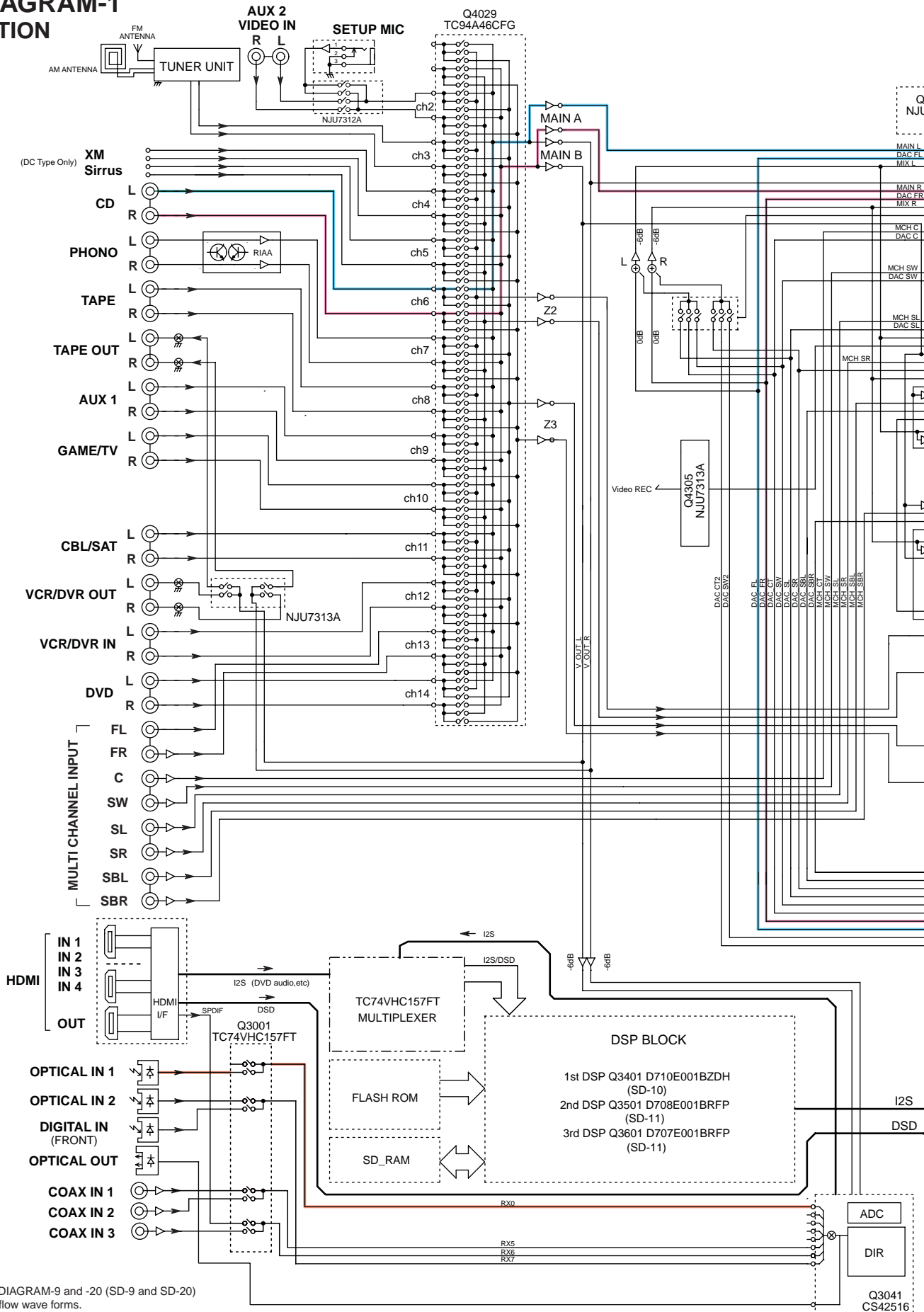

<Note>
Refer to SCHEMATIC DIAGRAM-9 and -20 (SD-9 and SD-20)
for digital audio signal flow wave forms.

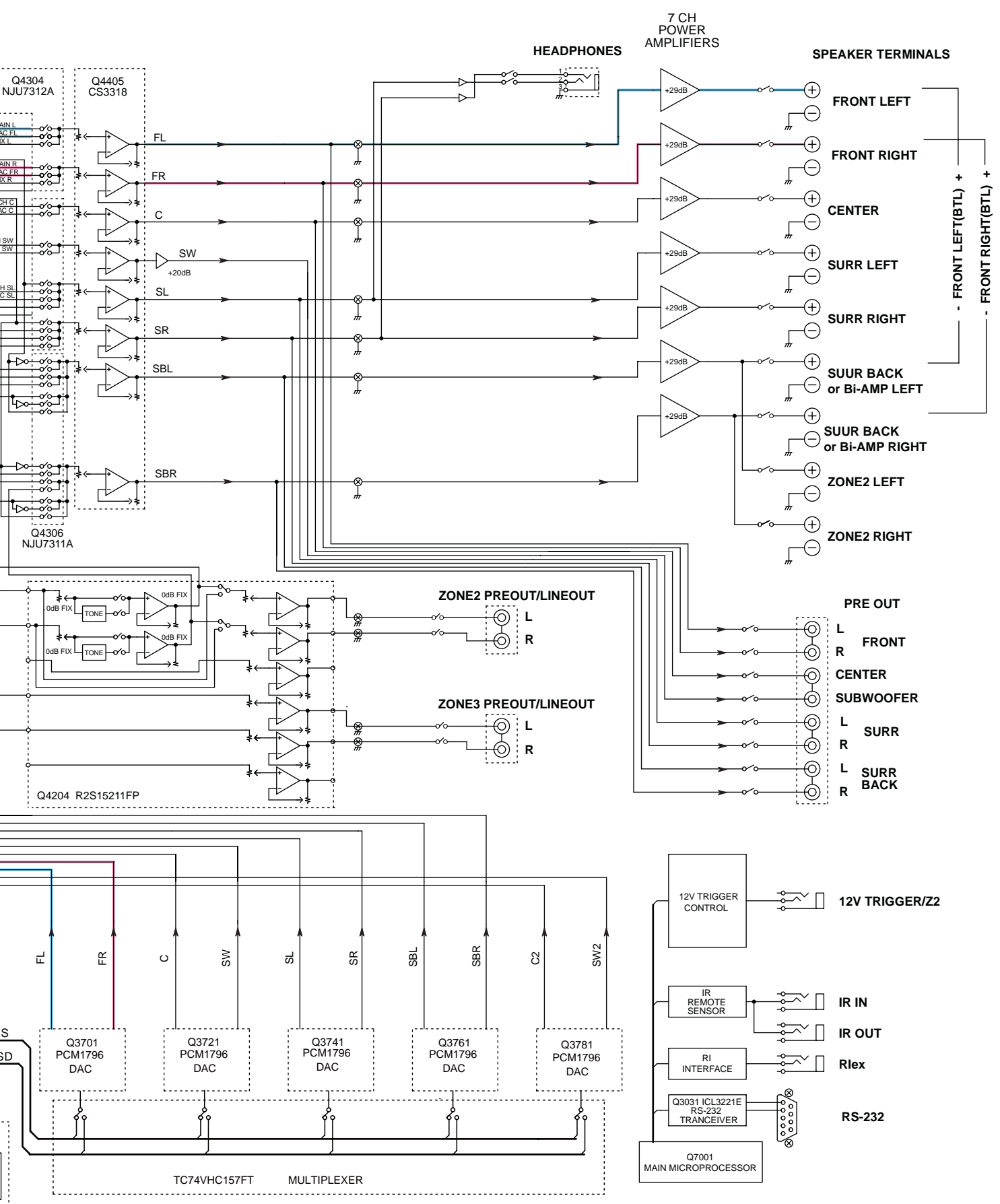

BLOCK DIAGRAM-2
VIDEO SECTION

1

2

3

4

5

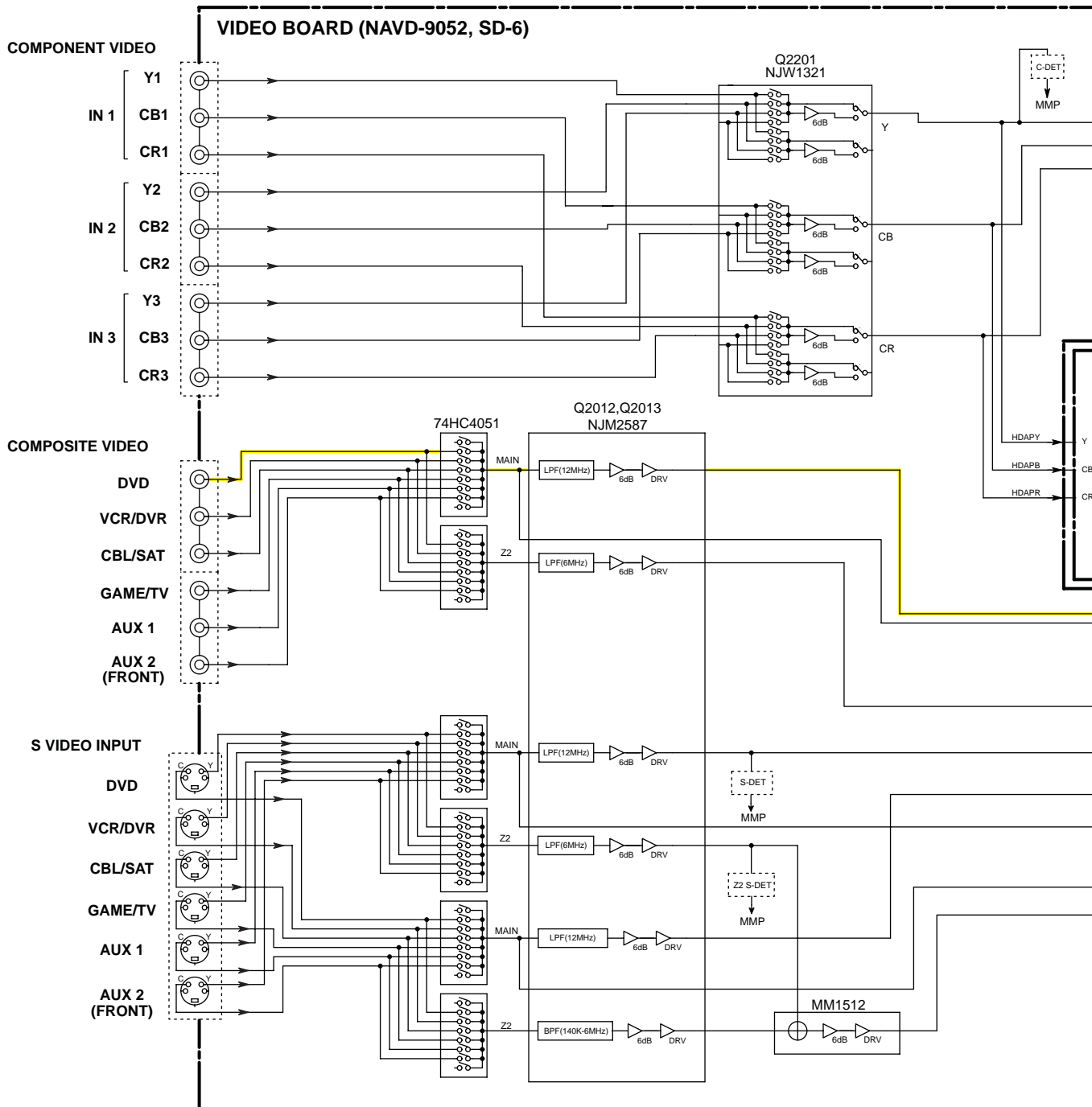

NOTE
MMP is short for MAIN MICROPROCESSOR.

E F G H

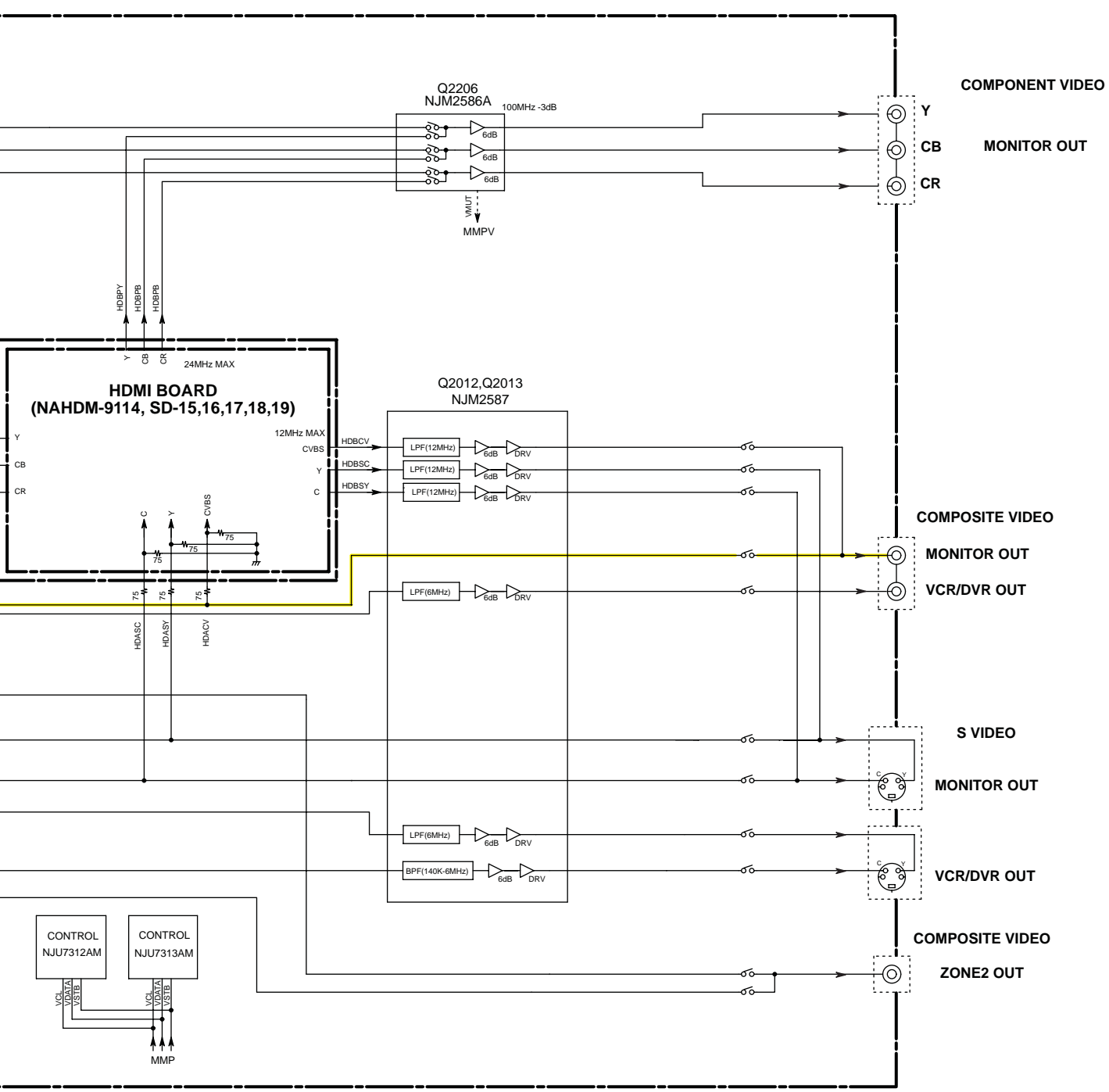

A

B

C

D

BLOCK DIAGRAM-3 HDMI SECTION

1

2

3

4

5

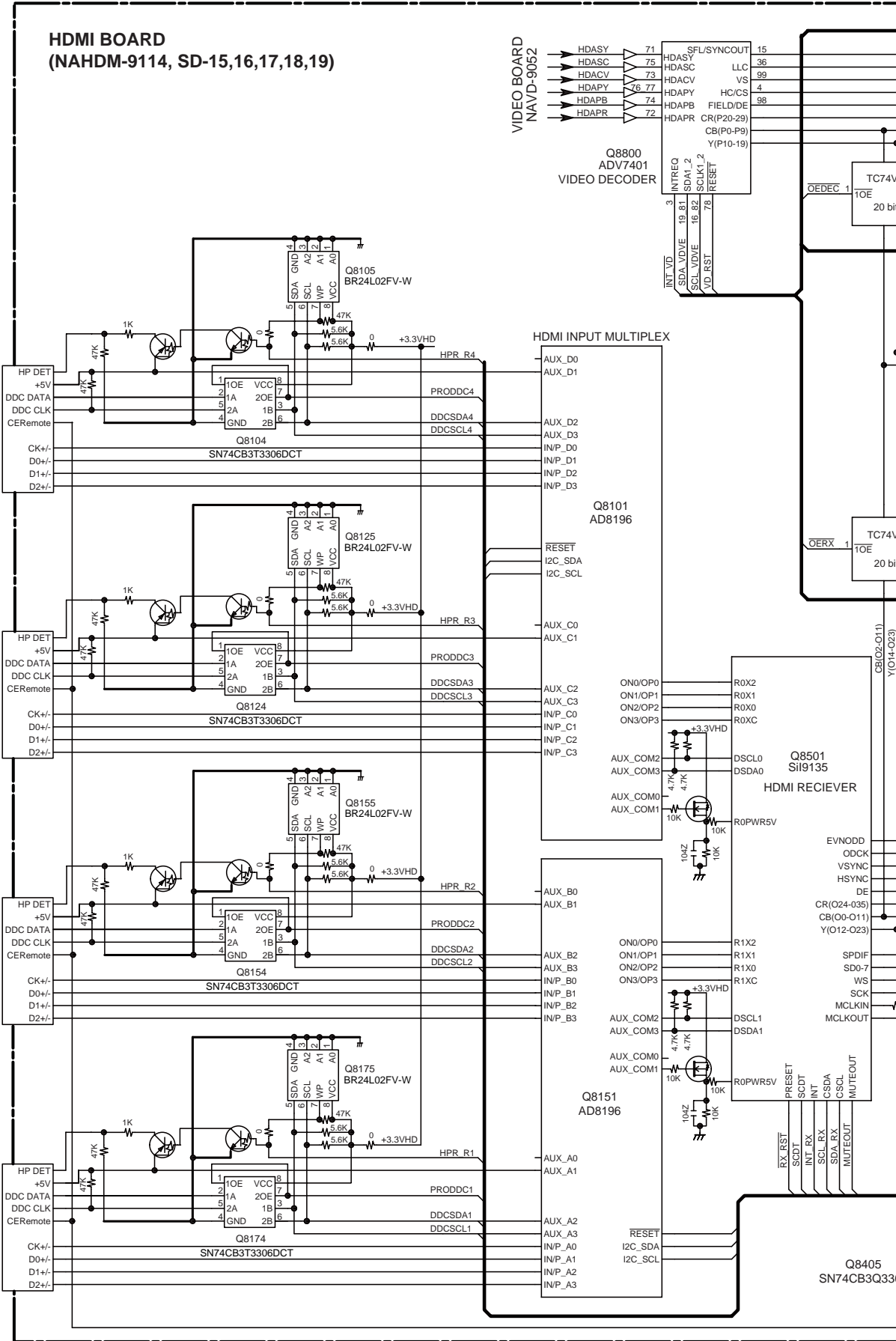

E

F

G

H

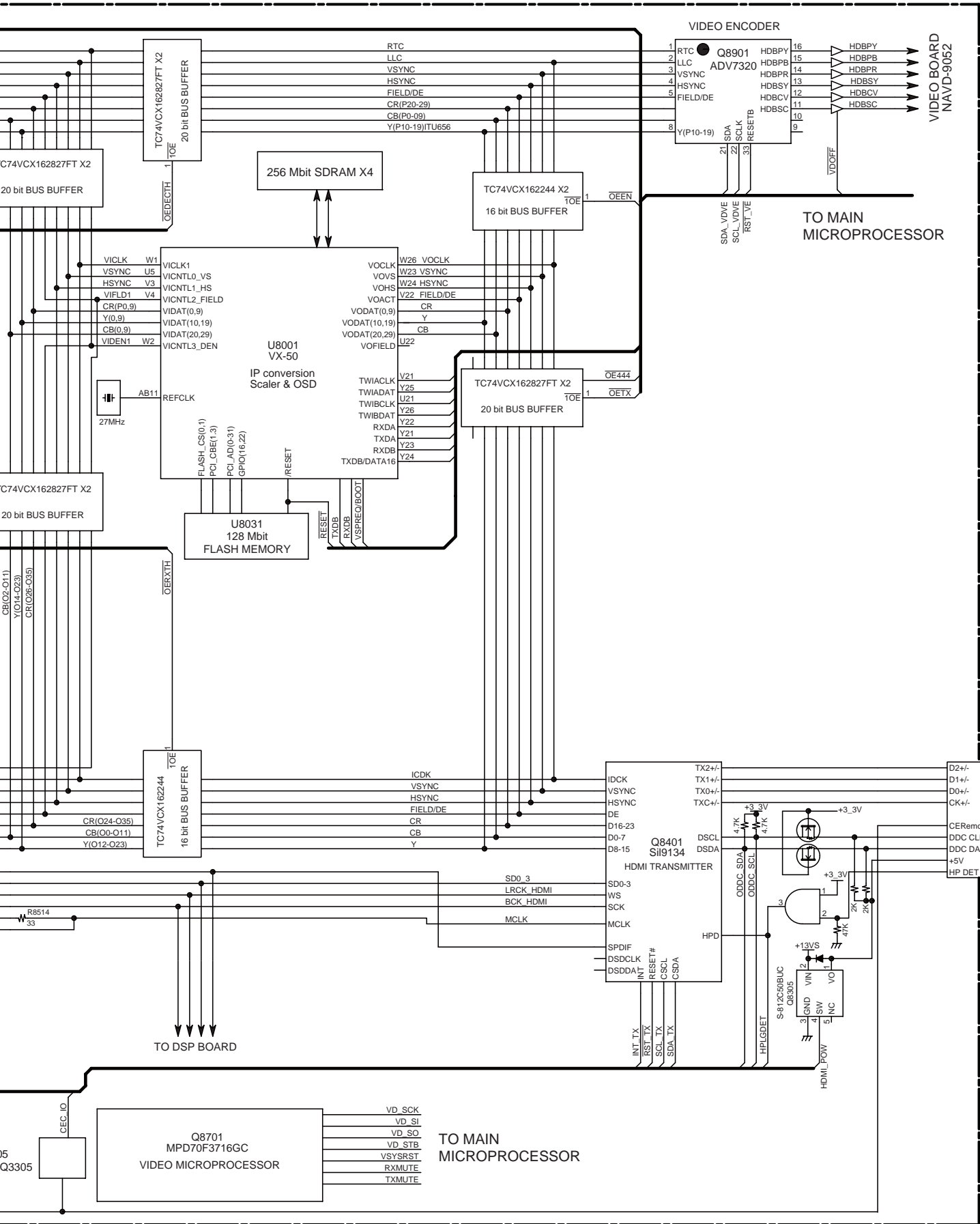

SCHEMATIC DIAGRAM-1 (SD-1) AUDIO SECTION

1
2
3
4
5

A

B

C

D

MULTI CH INPUT

NAASP-9050(1/2) **U06** AMPLIFIER PC BOARD

NAASP-9051 **U07** PHONO P

CD
L
R

TAPE OUT
L
R

TAPE
L
R

AUX1
L
R

GAME/TV
L
R

CBL/SAT
L
R

VCR/DVR OUT
L
R

VCR/DVR IN
L
R

DVD
L
R

FRONT
L
R

CENTER
SUB WOOFER

SURROUND
L
R

SURROUND
BACK
L
R

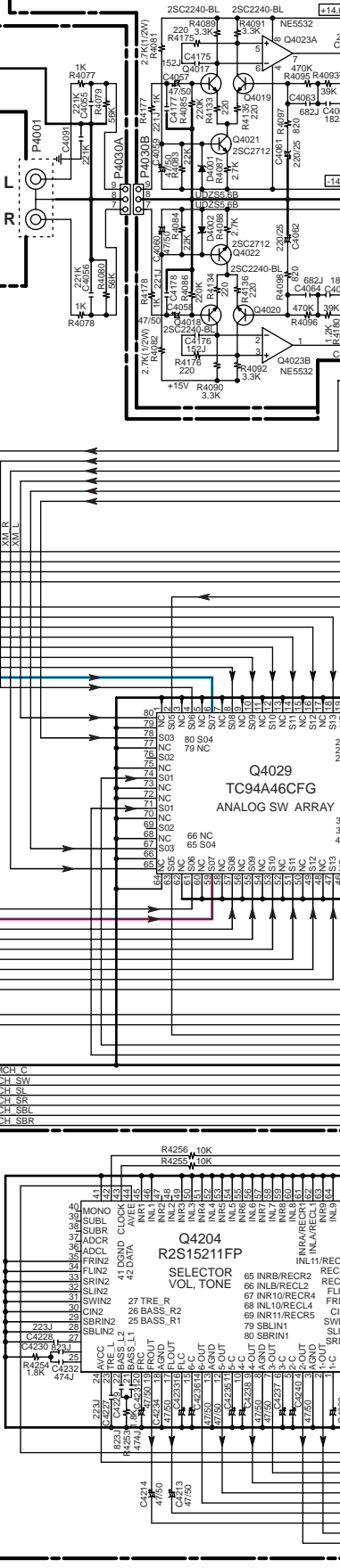
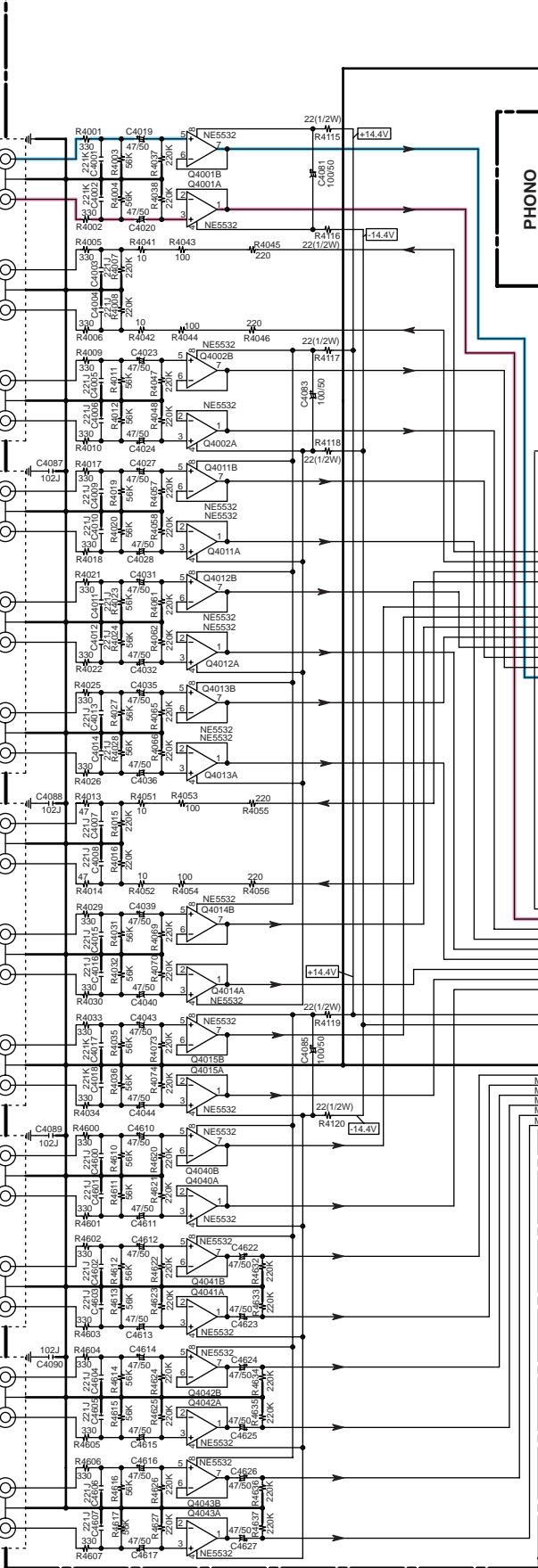

E

F

G

H

<Notes>
SD-x:XY is short for Schematic Diagram-x and each socket's location, X=A to H, Y=1 to 5.

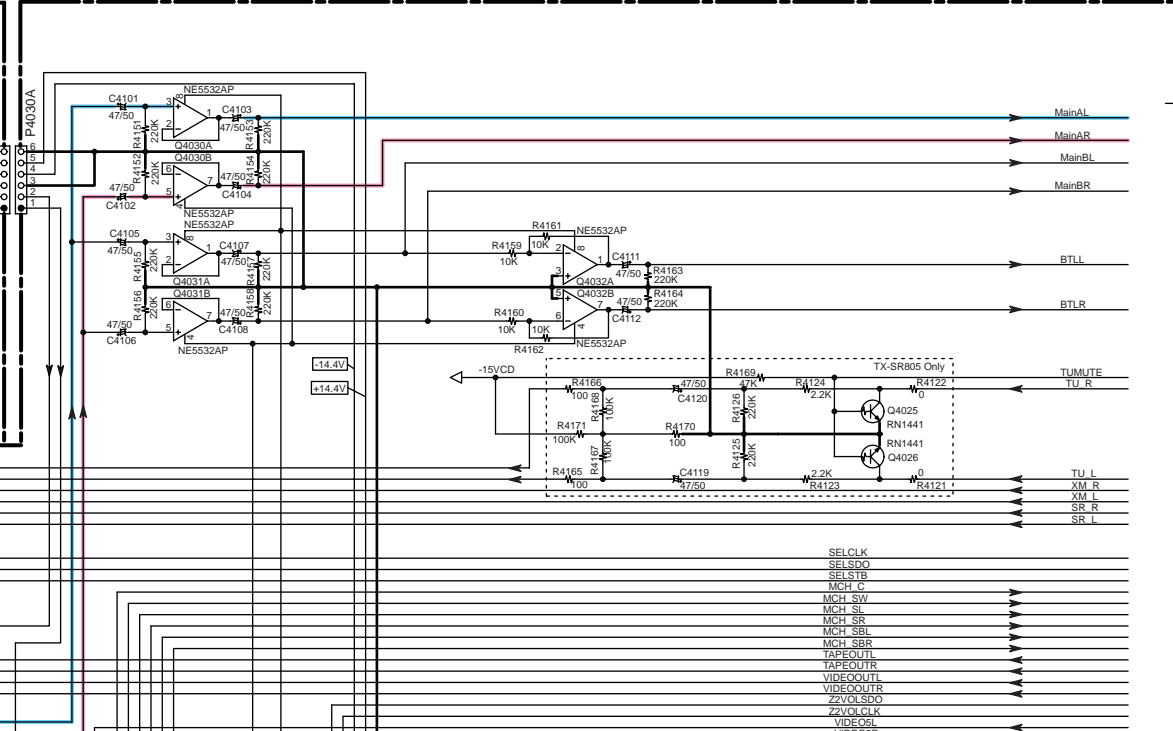
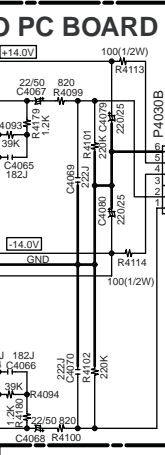

NAASP-9080 U32 AMPLIFIER PC BOARD

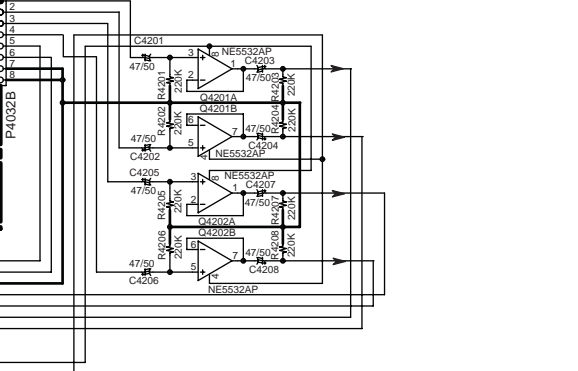

TO NAASP-9050(2/2)
SD-2

TO NAASP-9050(2/2)
SD-2

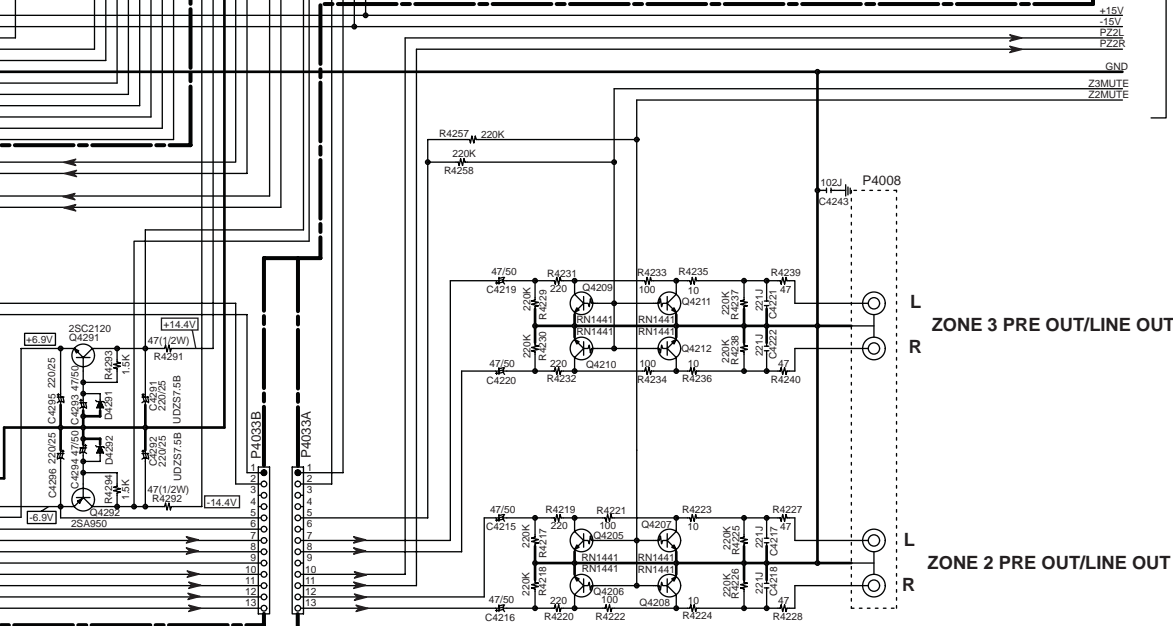
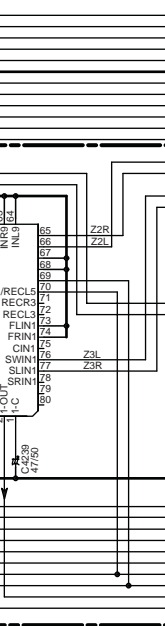

L
R
ZONE 3 PRE OUT/LINE OUT

L
R
ZONE 2 PRE OUT/LINE OUT

A

B

C

D

SCHEMATIC DIAGRAM-2 (SD-2) AUDIO SECTION

NAASP-9050(2/2) U06 AMPLIFIER PC BOARD

1

2

3

4

5

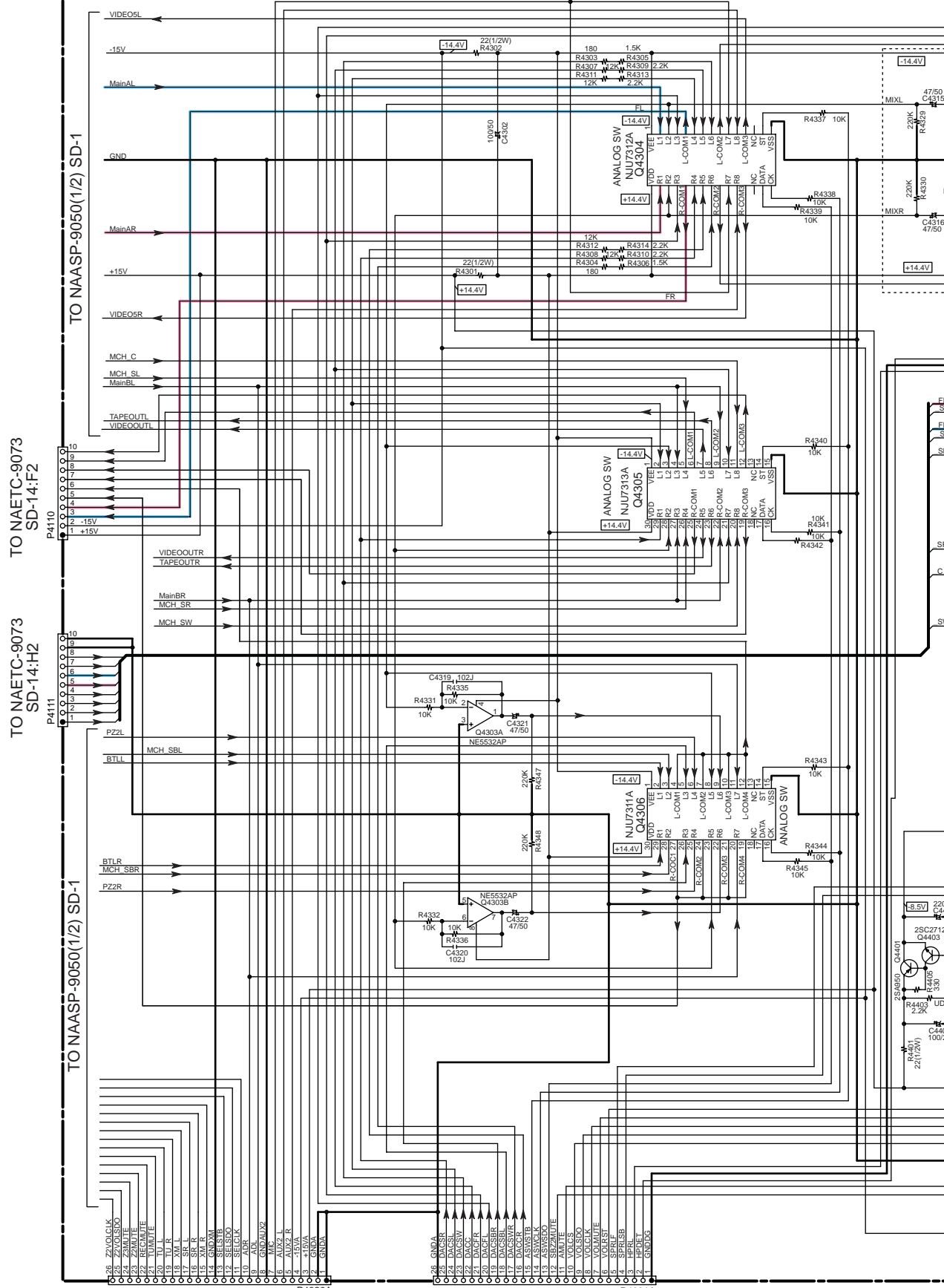

TO NAETC-9073
SD-14:F2

TO NAETC-9073
SD-14:H2

TO NAASP-9050(1/2) SD-1

TO NADG-9075
SD-8:F4

TO NADG-907
SD-8:G4

P4020A

P4021A

E

F

G

H

<Note>
SD-x:XY is short for Schematic Diagram-x and
each socket's location, X=A to H, Y=1 to 5.

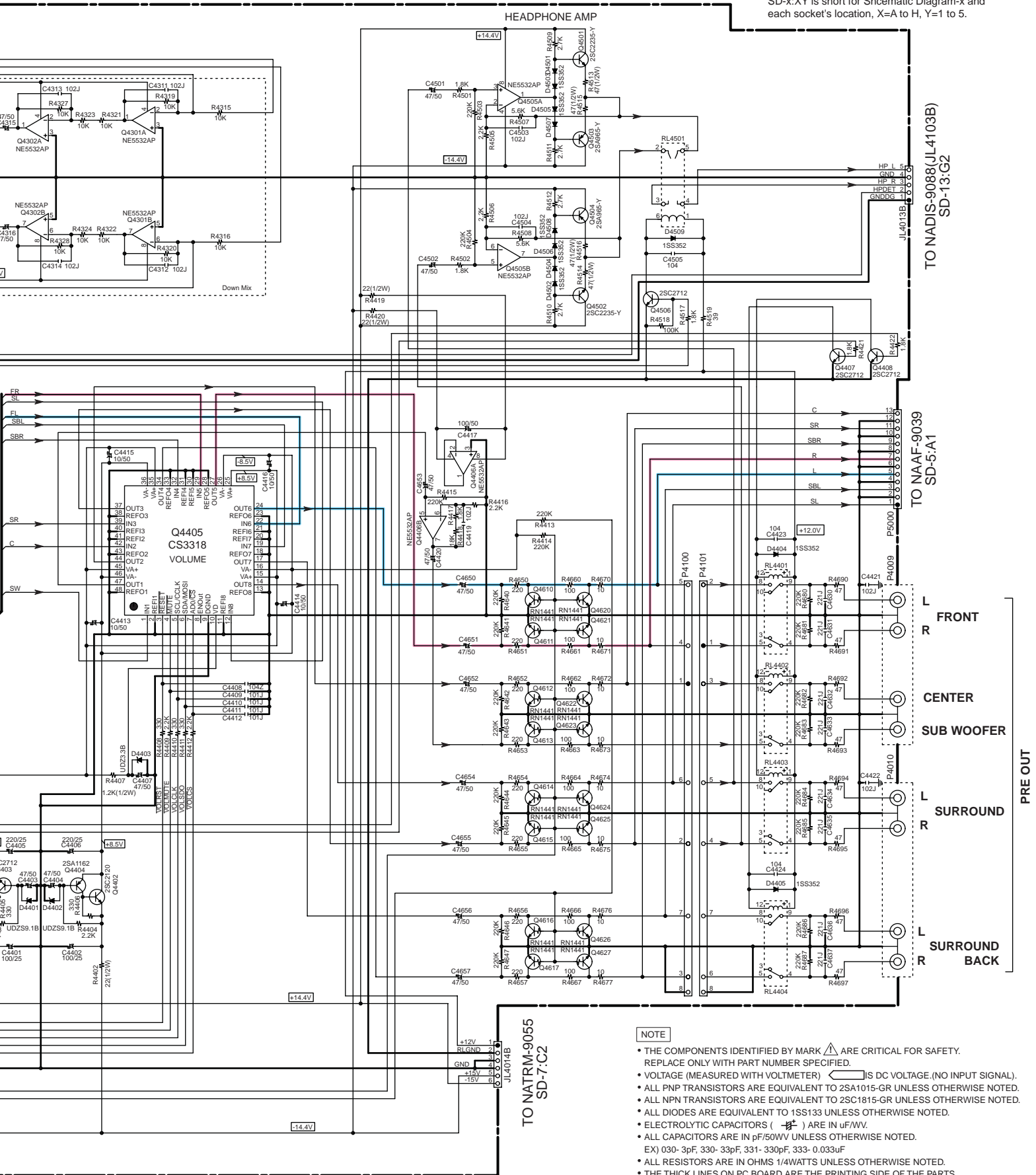

- NOTE**
- THE COMPONENTS IDENTIFIED BY MARK ARE CRITICAL FOR SAFETY. REPLACE ONLY WITH PART NUMBER SPECIFIED.
 - VOLTAGE (MEASURED WITH VOLTMETER) IS DC VOLTAGE.(NO INPUT SIGNAL).
 - ALL PNP TRANSISTORS ARE EQUIVALENT TO 2SA1015-GR UNLESS OTHERWISE NOTED.
 - ALL NPN TRANSISTORS ARE EQUIVALENT TO 2SC1815-GR UNLESS OTHERWISE NOTED.
 - ALL DIODES ARE EQUIVALENT TO 1SS133 UNLESS OTHERWISE NOTED.
 - ELECTROLYTIC CAPACITORS () ARE IN uF/WV.
 - ALL CAPACITORS ARE IN pF/50WV UNLESS OTHERWISE NOTED.
 - EX) 030- 3pF, 330- 33pF, 331- 330pF, 333- 0.033uF
 - ALL RESISTORS ARE IN OHMS 1/4WATTS UNLESS OTHERWISE NOTED.
 - THE THICK LINES ON PC BOARD ARE THE PRINTING SIDE OF THE PARTS.
 - EX) PRINTING SIDE
 - CIRCUIT IS SUBJECT TO CHANGE FOR IMPROVEMENT.

TO NADIS-9088(JL4103B)
SD-1:3:G2

TO NAAF-9039
SD-5:A1

FRONT
L
R

CENTER
SUB WOOFER

SURROUND
L
R

SURROUND BACK
L
R

TO NATRM-9055
SD-7:C2

A

B

C

D

SCHEMATIC DIAGRAM-3 (SD-3) POWER AMPLIFIER SECTION-1

1

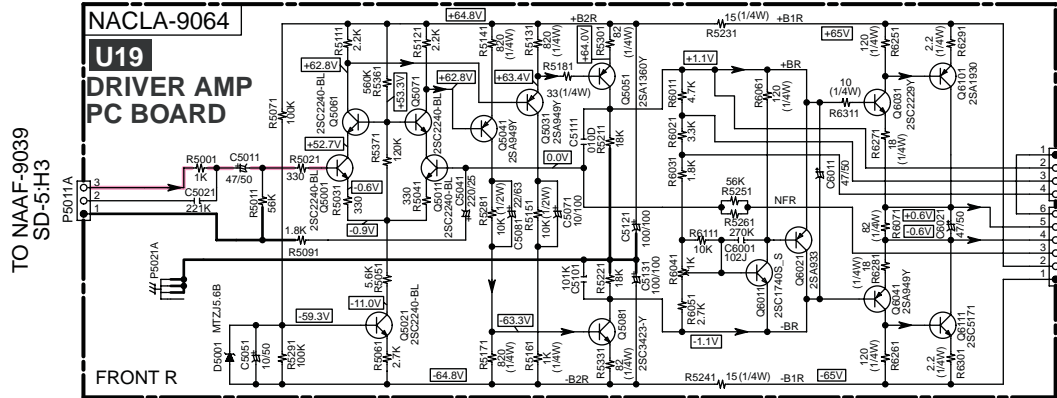

2

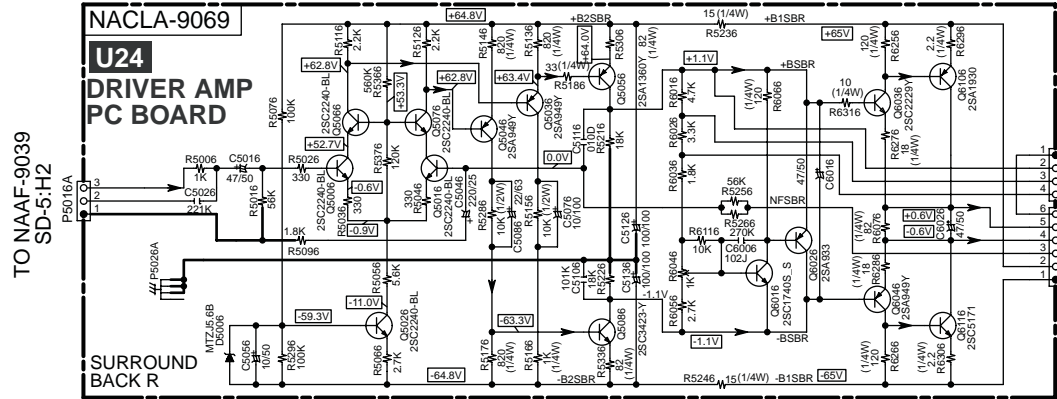

3

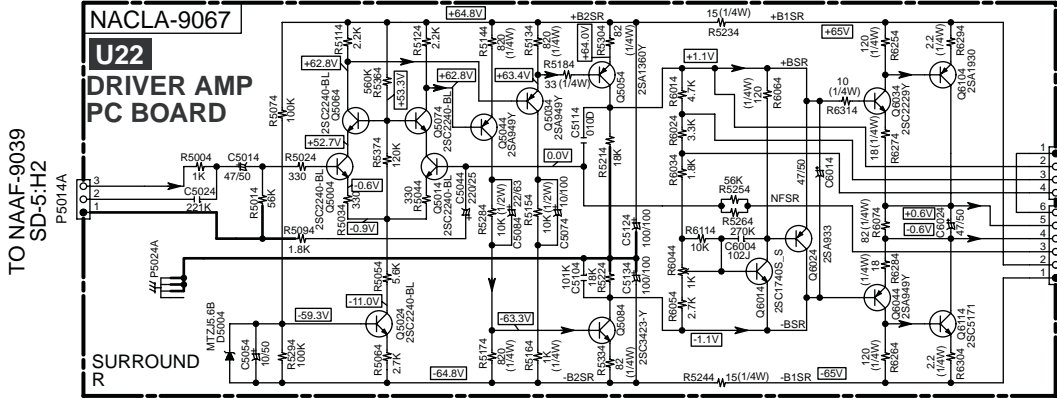

4

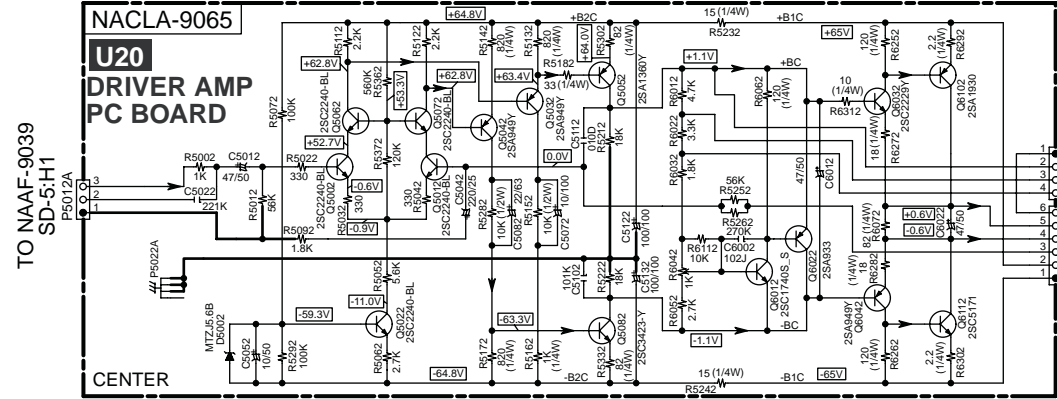

5

TO NAAF-9039 SD-5:H3 P6031A, P6031B

TO NAAF-9039 SD-5:H2 P6036A, P6036B

TO NAAF-9039 SD-5:H2 P6044A, P6044B

TO NAAF-9039 SD-5:H1 P6032B, P6032C

NACLA-9064,65,67,69 are fully compatible with each other.

A

B

C

D

SCHEMATIC DIAGRAM-4 (SD-4)
POWER AMPLIFIER SECTION-2

TO NAAF-9039
SD-5:F3

NAAMP-9062

U17 POWER AMP
PC BOARD

1

FRONT R

TO NACLA-9064
SD-3:D2

TO NATRM-9055
SD-7:D5

2

SURROUND BACK
R

TO NACLA-9069
SD-3:D3

TO NATRM-9055
SD-7:D5

3

SURROUND R

TO NACLA-9067
SD-3:D4

TO NATRM-9055
SD-7:D5

4

CENTER

TO NACLA-9065
SD-3:D5

TO NATRM-9055
SD-7:D5

5

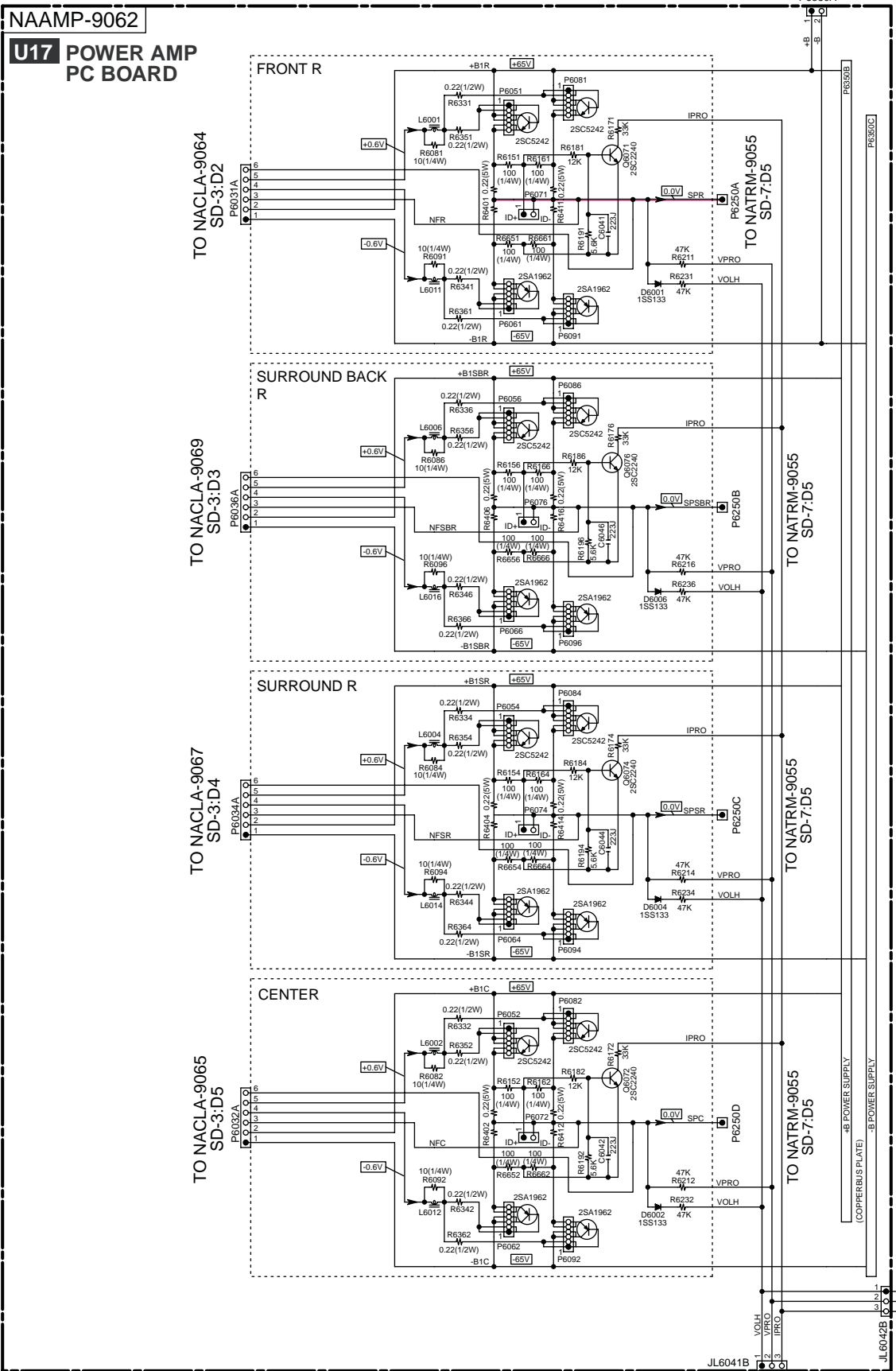

TO NAAF-9039
SD-5:E3

JL6042B
1 2 3
VOLH
VPRO
IPRO

TO NAAF-9039
SD-5:F3

NAAMP-9061

**U16 POWER AMP
PC BOARD**

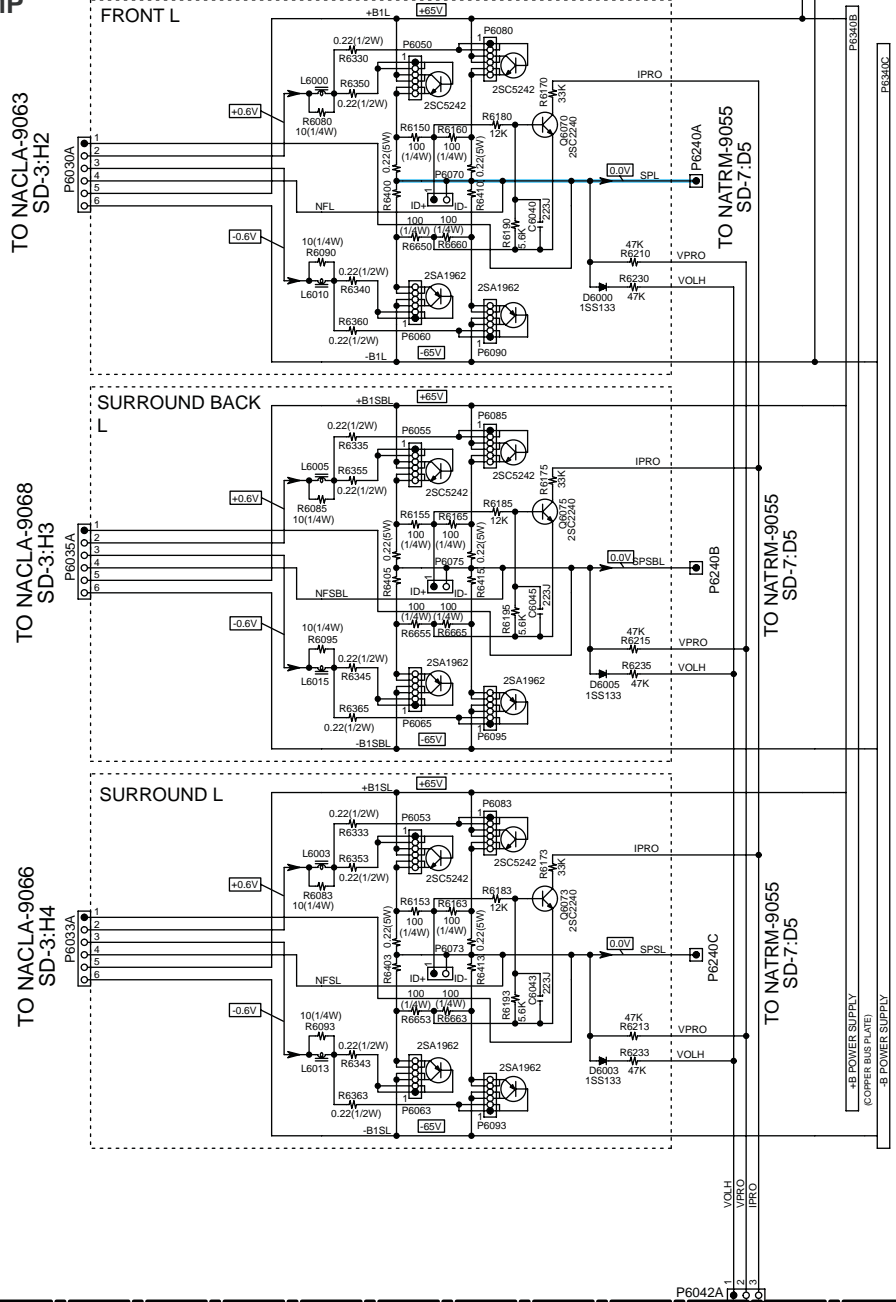

NOTE

- THE COMPONENTS IDENTIFIED BY MARK ARE CRITICAL FOR SAFETY. REPLACE ONLY WITH PART NUMBER SPECIFIED.
- VOLTAGE (MEASURED WITH VOLTMETER) IS DC VOLTAGE.(NO INPUT SIGNAL).
- ALL PNP TRANSISTORS ARE EQUIVALENT TO 2SA1015-GR UNLESS OTHERWISE NOTED.
- ALL NPN TRANSISTORS ARE EQUIVALENT TO 2SC1815-GR UNLESS OTHERWISE NOTED.
- ALL DIODES ARE EQUIVALENT TO 1SS133 UNLESS OTHERWISE NOTED.
- ELECTROLYTIC CAPACITORS () ARE IN uF/WV.
- ALL CAPACITORS ARE IN pF/50WV UNLESS OTHERWISE NOTED.
EX) 030- 3pF, 330- 33pF, 331- 330pF, 333- 0.033uF
- ALL RESISTORS ARE IN OHMS 1/4WATTS UNLESS OTHERWISE NOTED.
- THE THICK LINES ON PC BOARD ARE THE PRINTING SIDE OF THE PARTS.
EX) PRINTING SIDE
- CIRCUIT IS SUBJECT TO CHANGE FOR IMPROVEMENT.

<Note>
SD-x:XY is short for Schematic Diagram-x and each socket's location, X=A to H, Y=1 to 5.

SCHEMATIC DIAGRAM-5 (SD-5)
POWER SUPPLY SECTION

1

2

3

4

5

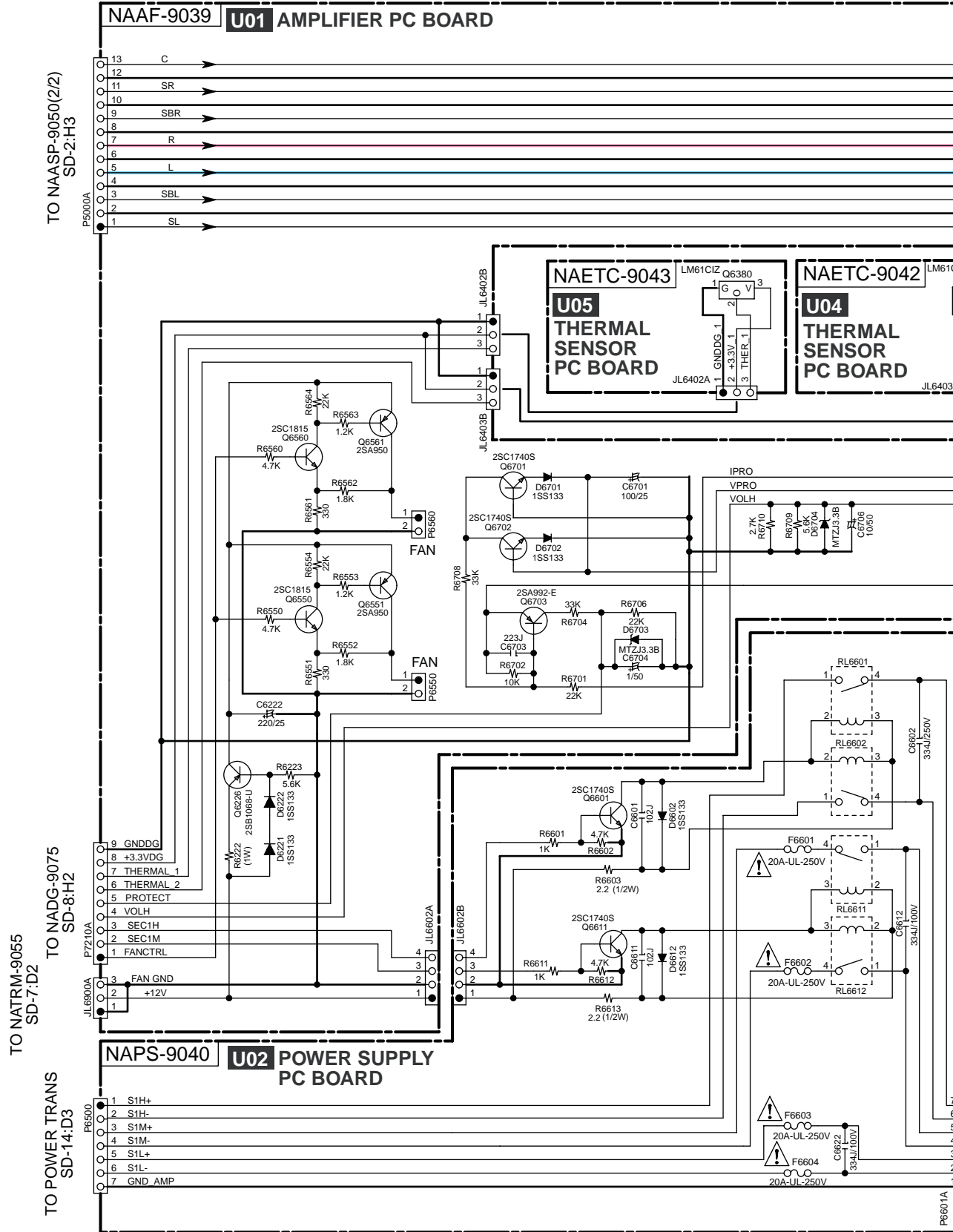

E F G H

<Note>
SD-x:XY is short for Shcematic Diagram-x and each socket's location, X=A to H, Y=1 to 5.

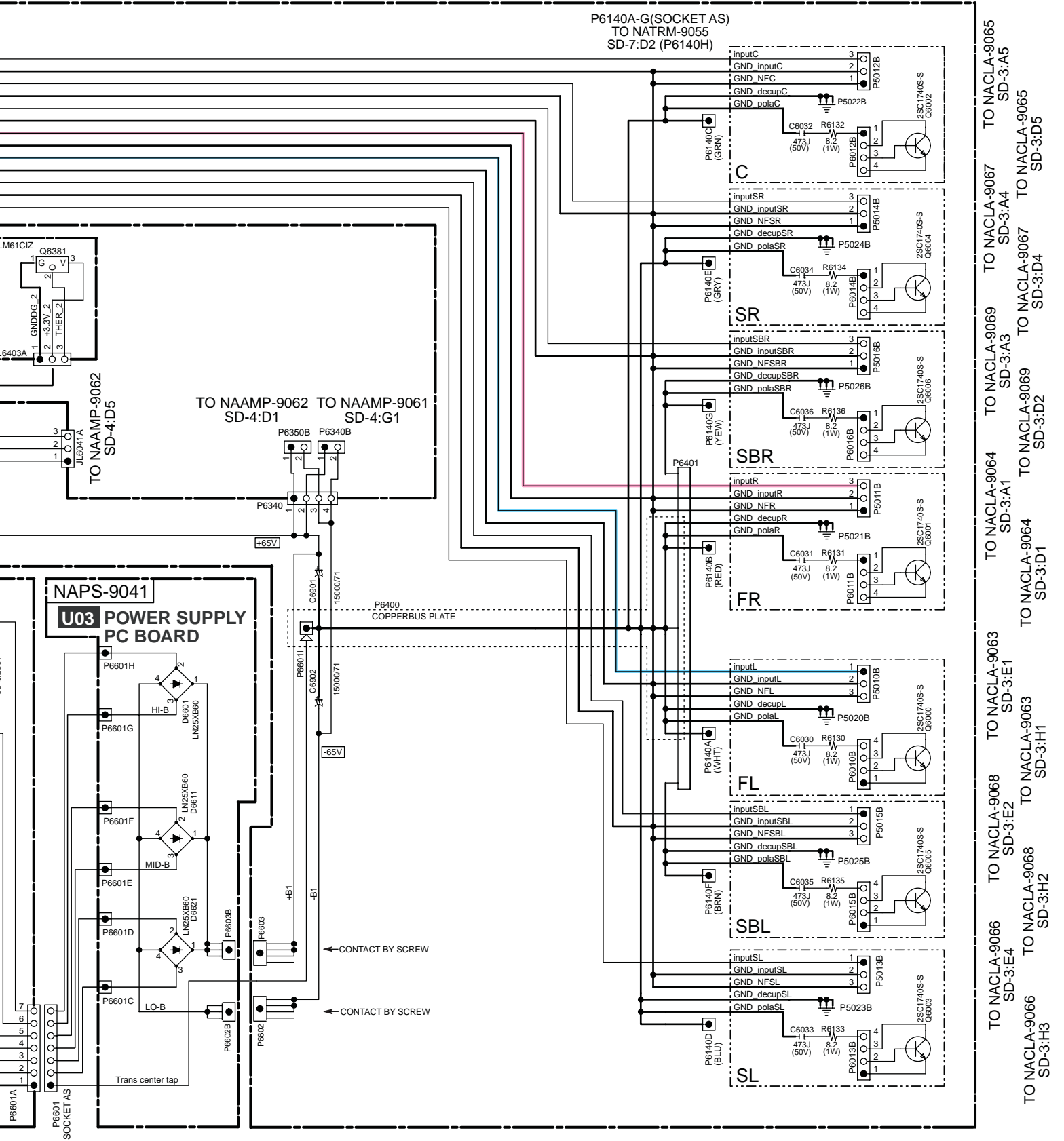

SCHEMATIC DIAGRAM-6 (SD-6) VIDEO SECTION

1

2

3

4

5

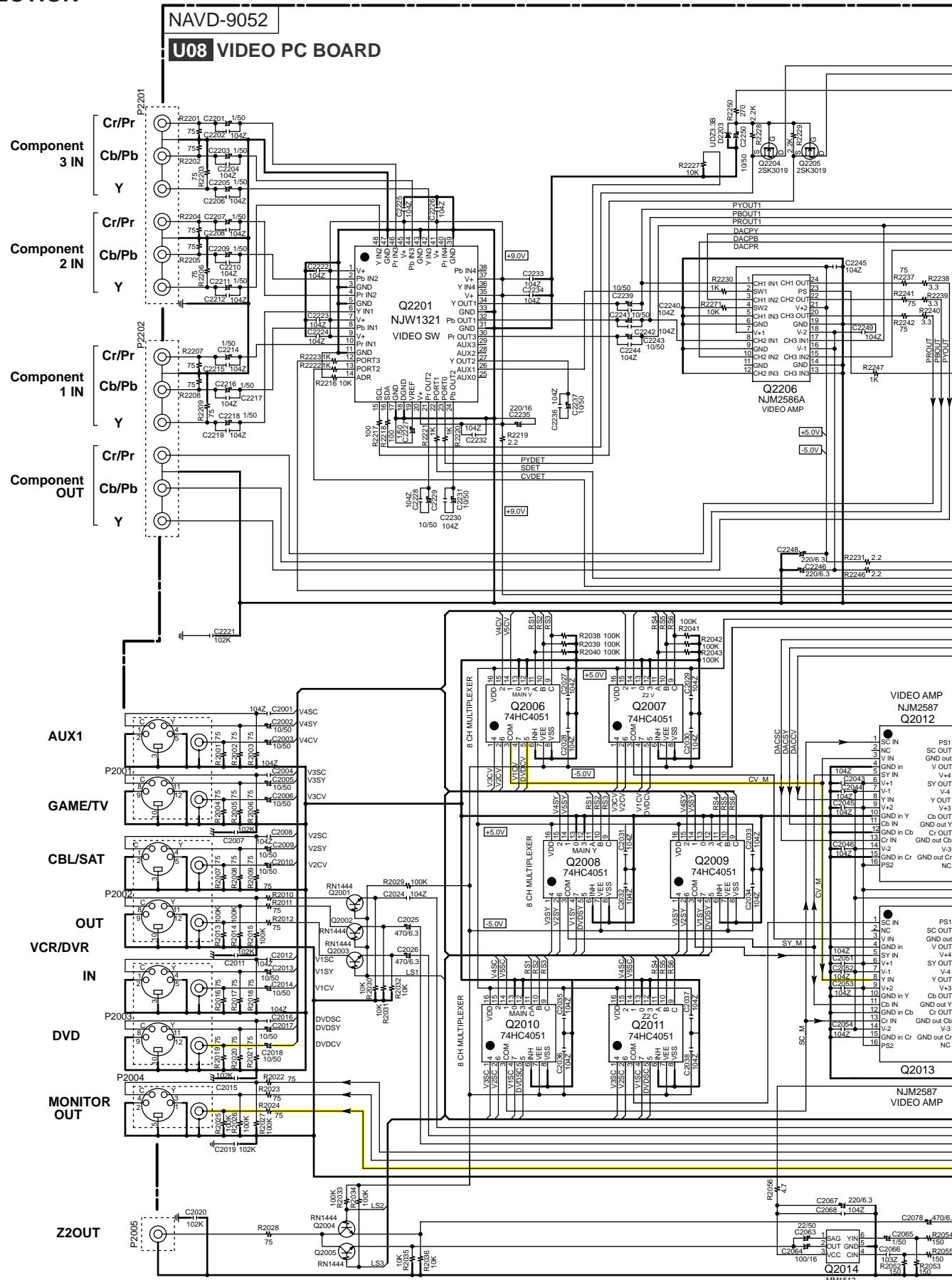

TO NADG-9075
SD-8:G3

<Note>
SD-x:XY is short for Shcematic Diagram-x and
each socket's location, X=A to H, Y=1 to 5.

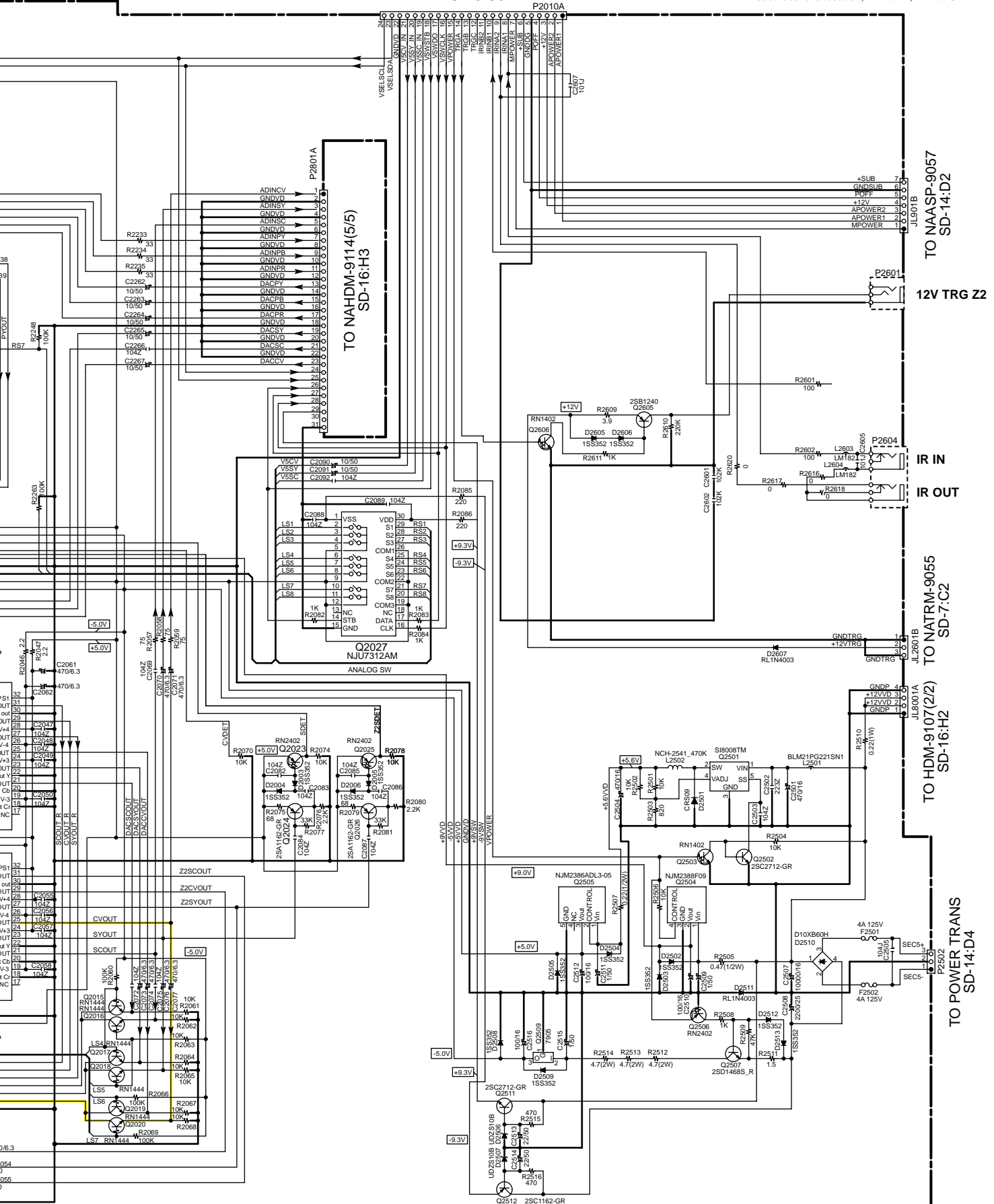

TO NAASP-9057
SD-14:D2

12V TRG Z2

IR IN
IR OUT

TO NATRM-9055
SD-7:C2

TO HDM-9107(2/2)
SD-16:H2

TO POWER TRANS
SD-14:D4

SCHEMATIC DIAGRAM-7 (SD-7)
SP TERMINAL SECTION

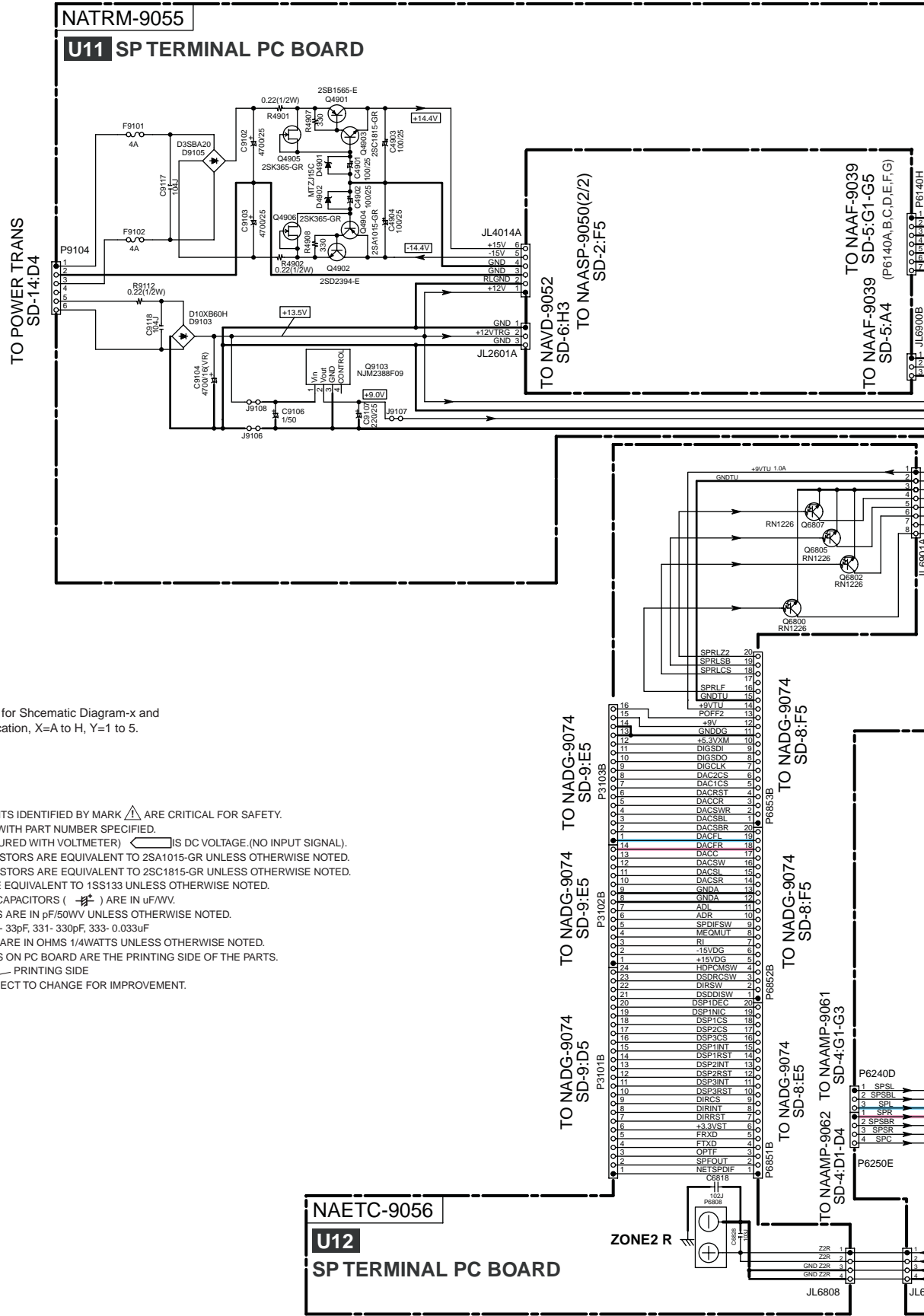

<Note>
 SD-x:XY is short for Schematic Diagram-x and each socket's location, X=A to H, Y=1 to 5.

NOTE

- THE COMPONENTS IDENTIFIED BY MARK \triangle ARE CRITICAL FOR SAFETY. REPLACE ONLY WITH PART NUMBER SPECIFIED.
- VOLTAGE (MEASURED WITH VOLTMETER) \triangle IS DC VOLTAGE. (NO INPUT SIGNAL).
- ALL PNP TRANSISTORS ARE EQUIVALENT TO 2SA1015-GR UNLESS OTHERWISE NOTED.
- ALL NPN TRANSISTORS ARE EQUIVALENT TO 2SC1815-GR UNLESS OTHERWISE NOTED.
- ALL DIODES ARE EQUIVALENT TO 1SS133 UNLESS OTHERWISE NOTED.
- ELECTROLYTIC CAPACITORS (---) ARE IN $\mu\text{F}/\text{V}$.
- ALL CAPACITORS ARE IN pF/50V UNLESS OTHERWISE NOTED.
 EX) 030- 3pF, 330- 33pF, 331- 330pF, 333- 0.033 μF
- ALL RESISTORS ARE IN OHMS 1/4WATTS UNLESS OTHERWISE NOTED.
 EX) \square PRINTING SIDE
- THE THICK LINES ON PC BOARD ARE THE PRINTING SIDE OF THE PARTS.
- CIRCUIT IS SUBJECT TO CHANGE FOR IMPROVEMENT.

1

2

3

4

5

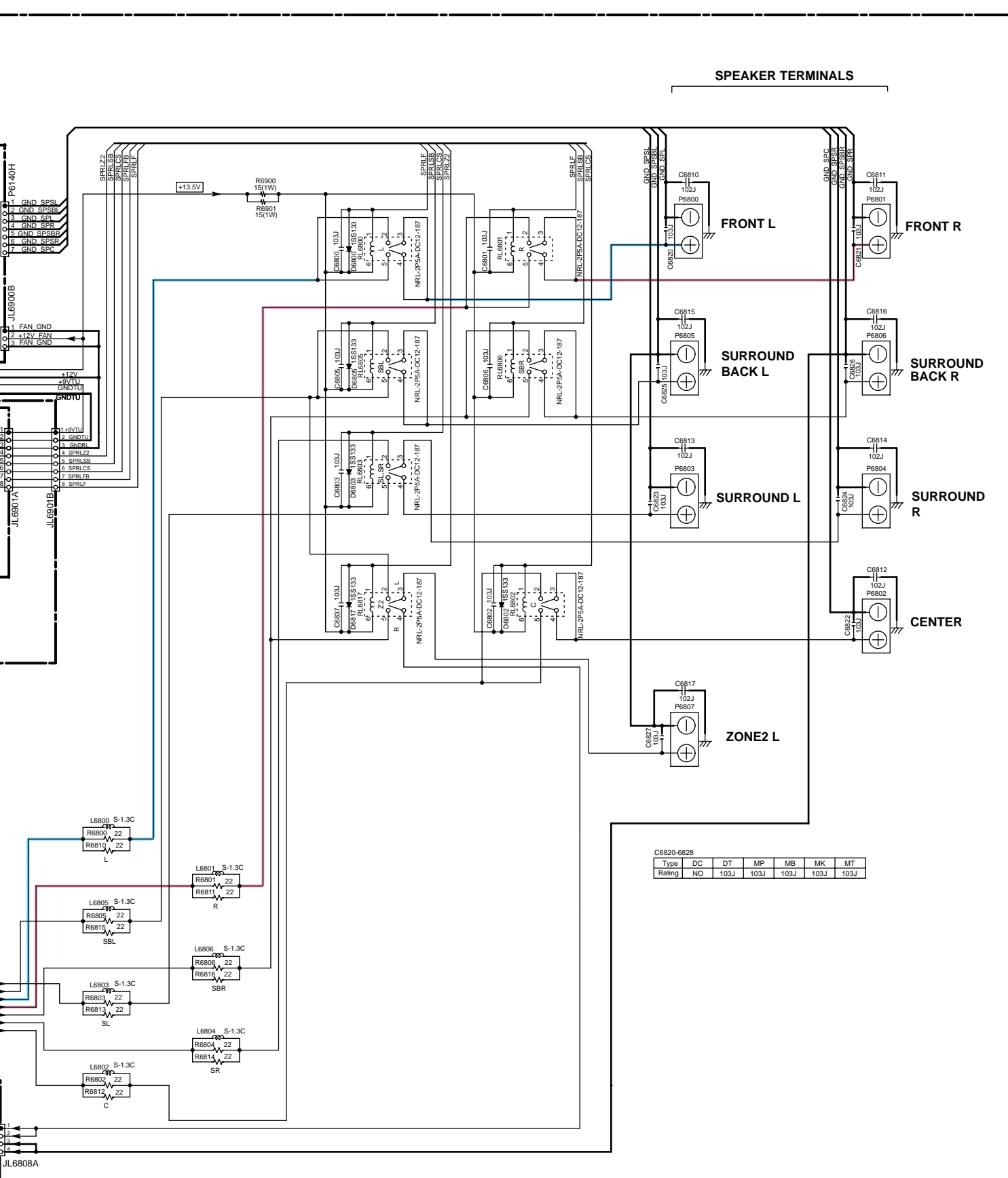

C6820-6828

Type	DC	DT	MP	MB	MK	MT
Rating	NO	103J	103J	103J	103J	103J

JL6808A

A

B

C

D

SCHEMATIC DIAGRAM-8 (SD-8)
MICROPROCESSOR SECTION

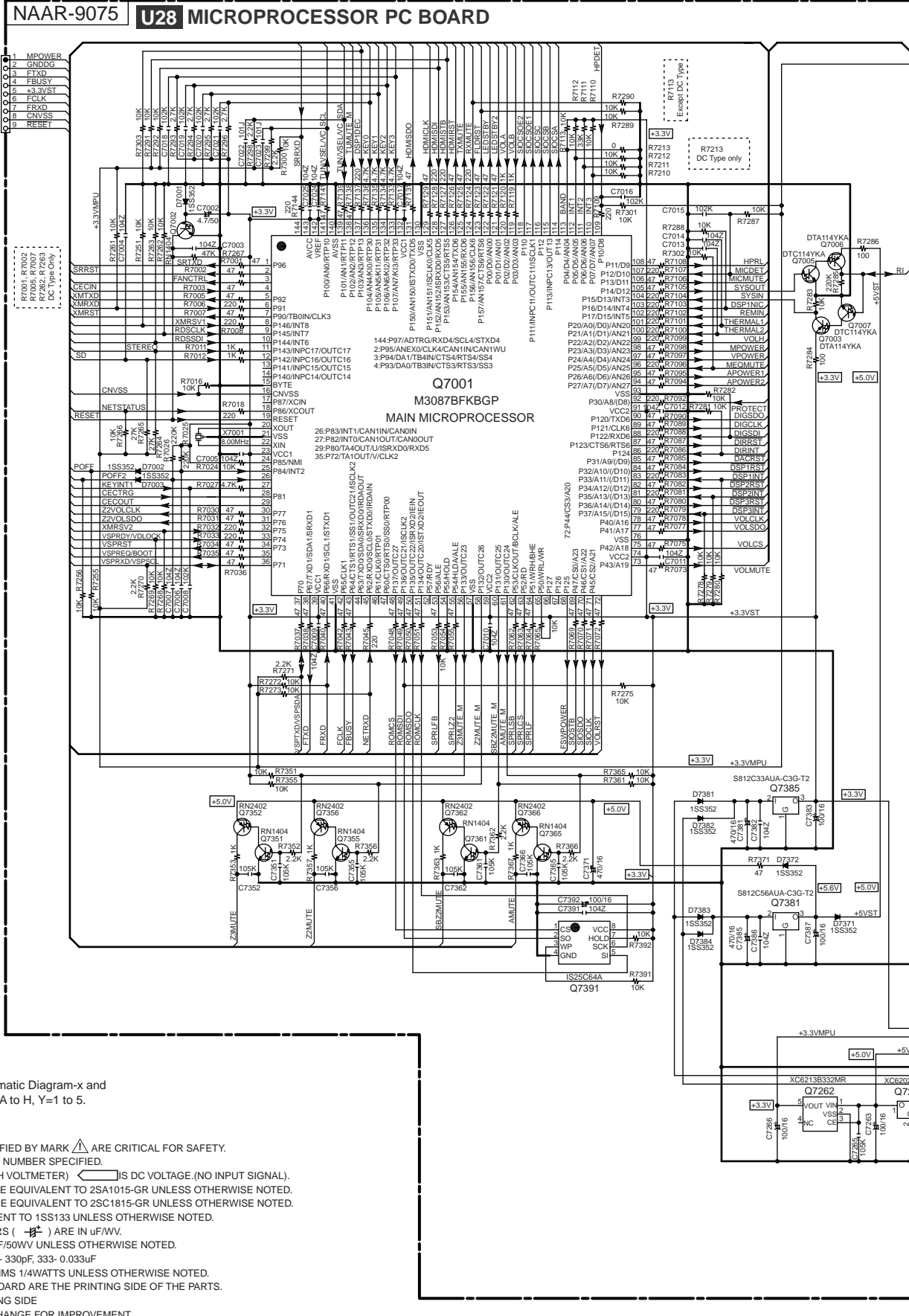

<Note>
SD-x:XY is short for Schematic Diagram-x and each socket's location, X=A to H, Y=1 to 5.

NOTE

- THE COMPONENTS IDENTIFIED BY MARK ARE CRITICAL FOR SAFETY. REPLACE ONLY WITH PART NUMBER SPECIFIED.
- VOLTAGE (MEASURED WITH VOLTMETER) IS DC VOLTAGE.(NO INPUT SIGNAL).
- ALL PNP TRANSISTORS ARE EQUIVALENT TO 2SA1015-GR UNLESS OTHERWISE NOTED.
- ALL NPN TRANSISTORS ARE EQUIVALENT TO 2SC1815-GR UNLESS OTHERWISE NOTED.
- ALL DIODES ARE EQUIVALENT TO 1SS133 UNLESS OTHERWISE NOTED.
- ELECTROLYTIC CAPACITORS () ARE IN uF/MV.
- ALL CAPACITORS ARE IN pF/50VV UNLESS OTHERWISE NOTED.
EX) 030- 3pF, 330- 33pF, 331- 330pF, 333- 0.033uF
- ALL RESISTORS ARE IN OHMS 1/4WATTS UNLESS OTHERWISE NOTED.
- THE THICK LINES ON PC BOARD ARE THE PRINTING SIDE OF THE PARTS.
- EX) PRINTING SIDE
- CIRCUIT IS SUBJECT TO CHANGE FOR IMPROVEMENT.

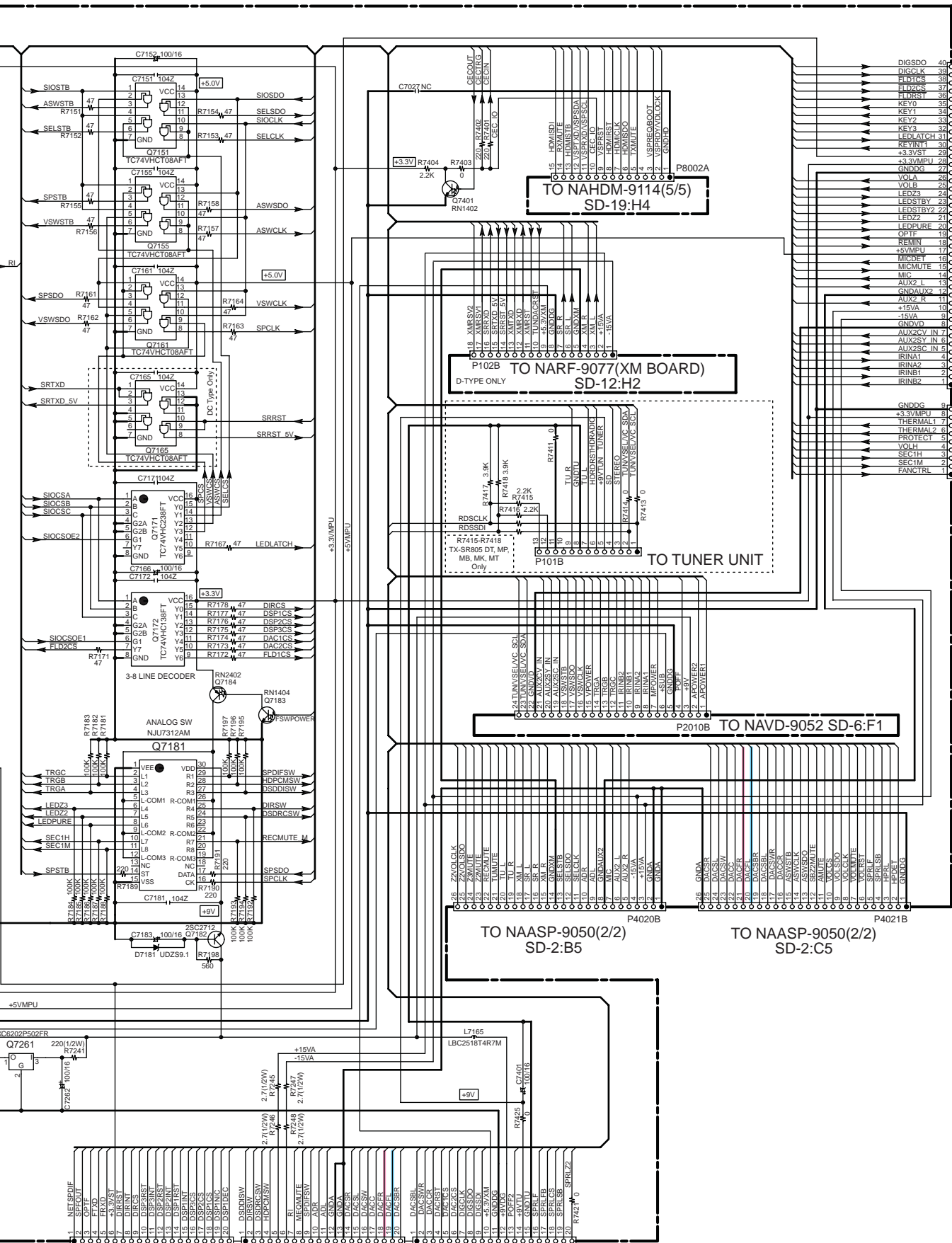

TO NAHDM-9114(5/5)
SD-19:H4

TO NARF-9077(XM BOARD)
SD-12:H2
D-TYPE ONLY

TO TUNER UNIT

TO NAVD-9052 SD-6:F1

TO NAASP-9050(2/2)
SD-2:B5

TO NAASP-9050(2/2)
SD-2:C5

TO NAASP-9056
SD-7:D5

TO NAASP-9056
SD-7:D4

TO NAASP-9056
SD-7:D3

P7501A

TO NADIS-9085
SD-13:B2

TO NAAF-9039
SD-5:A4

P7210B

P4020B

P4021B

P6851A

P6852A

P6853A

- 1. NEF SPDIF
- 2. SPDIF OUT
- 3. SPDIF
- 4. FTD
- 5. FTD
- 6. DIRINT
- 7. DIRINT
- 8. DIRINT
- 9. DIRINT
- 10. DSPFINST
- 11. DSPFINST
- 12. DSPFINST
- 13. DSPFINST
- 14. DSPFINST
- 15. DSPFINST
- 16. DSPFINST
- 17. DSPFINST
- 18. DSPFINST
- 19. DSPFINST
- 20. DSPFINST
- 21. DSPFINST
- 22. DSPFINST
- 23. DSPFINST
- 24. DSPFINST
- 25. DSPFINST
- 26. DSPFINST
- 27. DSPFINST
- 28. DSPFINST
- 29. DSPFINST
- 30. DSPFINST
- 31. DSPFINST
- 32. DSPFINST
- 33. DSPFINST
- 34. DSPFINST
- 35. DSPFINST
- 36. DSPFINST
- 37. DSPFINST
- 38. DSPFINST
- 39. DSPFINST
- 40. DSPFINST
- 41. DSPFINST
- 42. DSPFINST
- 43. DSPFINST
- 44. DSPFINST
- 45. DSPFINST
- 46. DSPFINST
- 47. DSPFINST
- 48. DSPFINST
- 49. DSPFINST
- 50. DSPFINST
- 51. DSPFINST
- 52. DSPFINST
- 53. DSPFINST
- 54. DSPFINST
- 55. DSPFINST
- 56. DSPFINST
- 57. DSPFINST
- 58. DSPFINST
- 59. DSPFINST
- 60. DSPFINST
- 61. DSPFINST
- 62. DSPFINST
- 63. DSPFINST
- 64. DSPFINST
- 65. DSPFINST
- 66. DSPFINST
- 67. DSPFINST
- 68. DSPFINST
- 69. DSPFINST
- 70. DSPFINST
- 71. DSPFINST
- 72. DSPFINST
- 73. DSPFINST
- 74. DSPFINST
- 75. DSPFINST
- 76. DSPFINST
- 77. DSPFINST
- 78. DSPFINST
- 79. DSPFINST
- 80. DSPFINST
- 81. DSPFINST
- 82. DSPFINST
- 83. DSPFINST
- 84. DSPFINST
- 85. DSPFINST
- 86. DSPFINST
- 87. DSPFINST
- 88. DSPFINST
- 89. DSPFINST
- 90. DSPFINST
- 91. DSPFINST
- 92. DSPFINST
- 93. DSPFINST
- 94. DSPFINST
- 95. DSPFINST
- 96. DSPFINST
- 97. DSPFINST
- 98. DSPFINST
- 99. DSPFINST
- 100. DSPFINST

SCHEMATIC DIAGRAM-9 (SD-9)
DAC SECTION

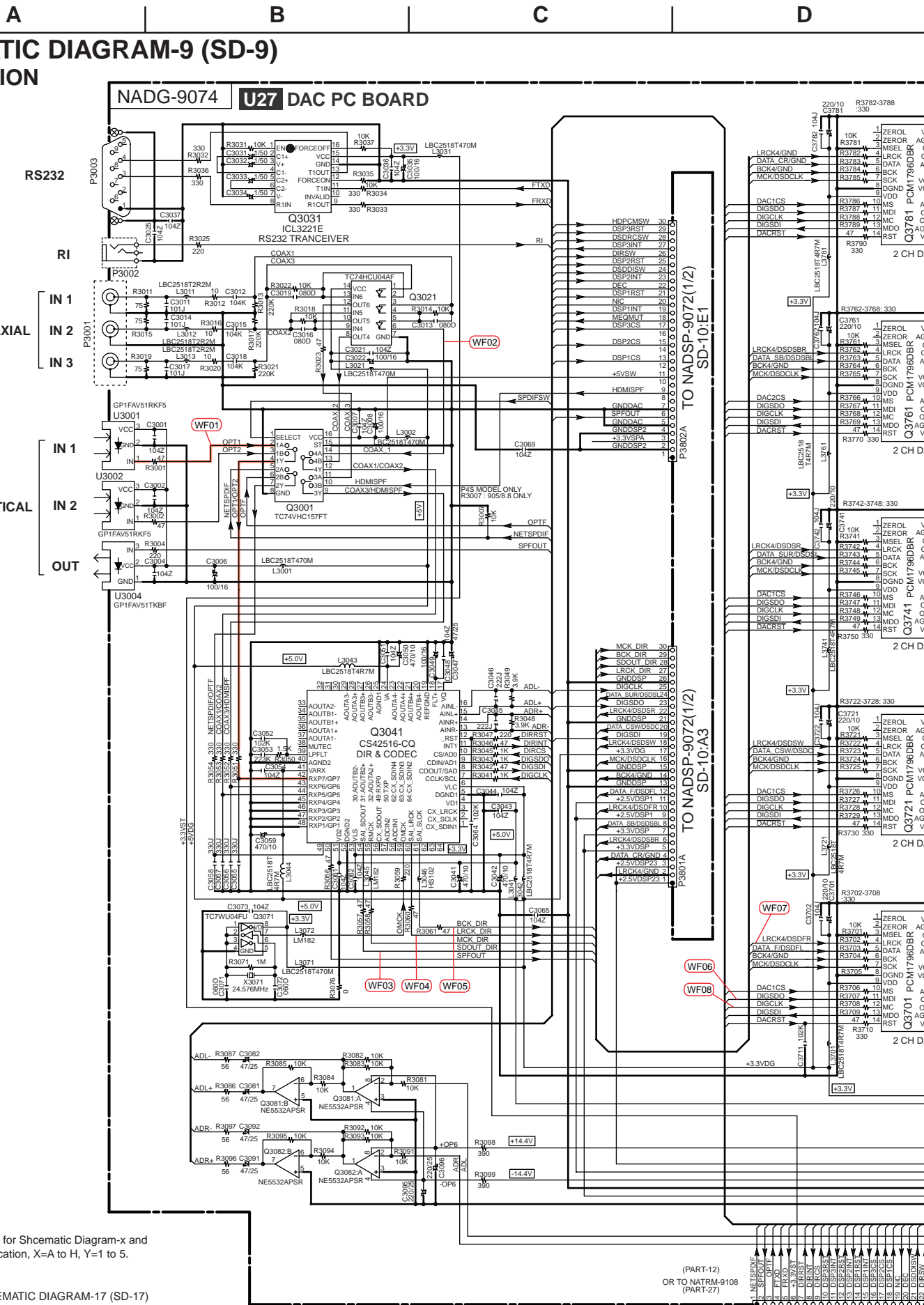

<Note>
SD-x:XY is short for Schematic Diagram-x and each socket's location, X=A to H, Y=1 to 5.

<Note>
1. Refer to SCHEMATIC DIAGRAM-17 (SD-17) for digital audio signal flow wave forms.
2. (WF01) is short for (WaveForm01).

(PART-12)
OR TO NATRM-9108
(PART-27)

TO NAASP-9056
SD-7:C5

E F G H

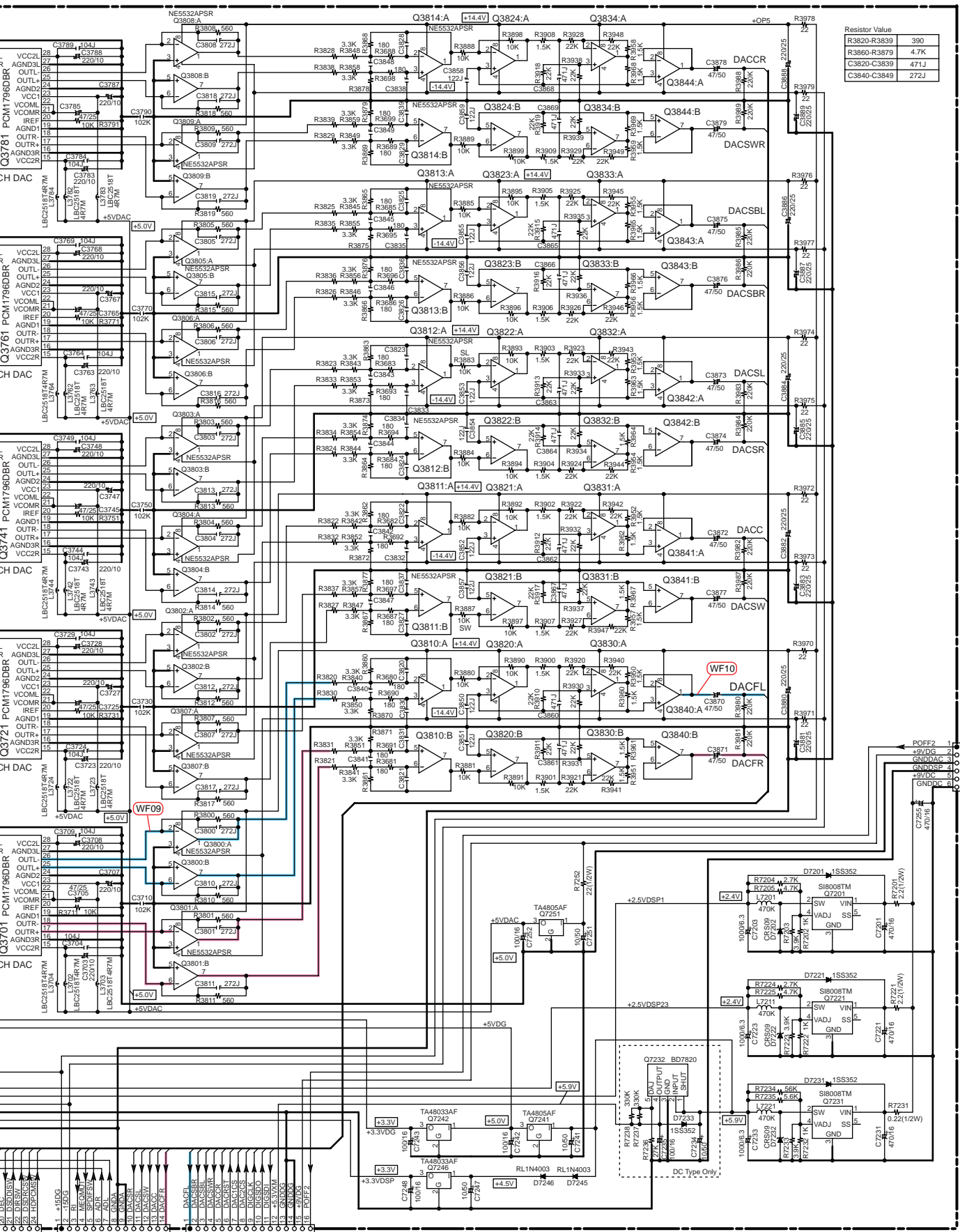

Resistor Value

R3820-R3839	390
R3860-R3879	4.7K
C3820-C3839	471J
C3840-C3849	272J

TO NADIS-9089
SD-14:G4

A B C D

SCHEMATIC DIAGRAM-10 (SD-10)
DSP SECTION

TO NAHDM-9114(5/5)
SD-19:H4

TO M...

1

2

3

4

5

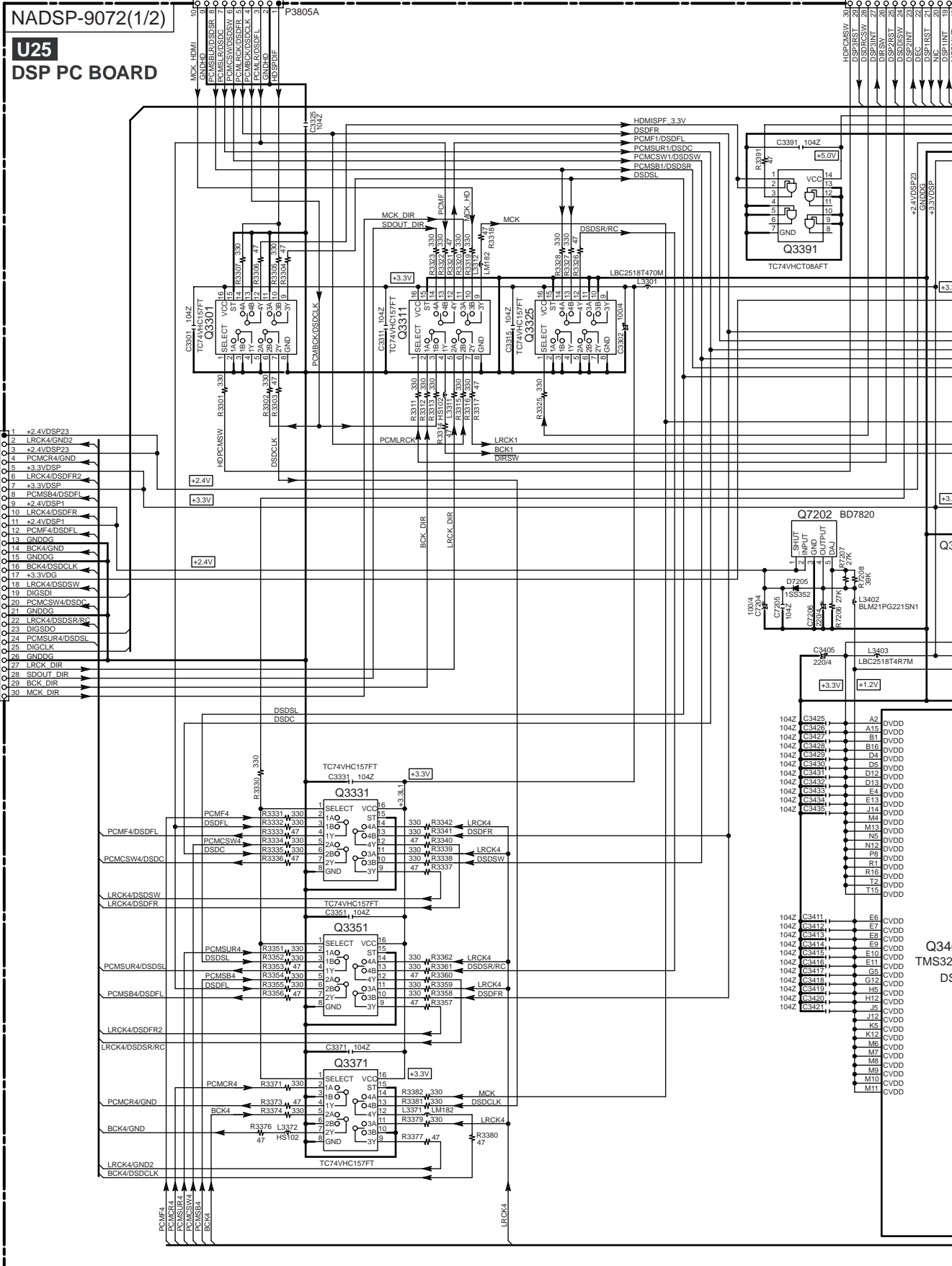

TO NADG-9074
SD-9:C3

Q3400
TMS320
DS1

E F G H

TO NADG-9074 SD-9:C2

<Notes>
SD-x:Y is short for Schematic Diagram-x and each socket's location, X=A to H, Y=1 to 5.

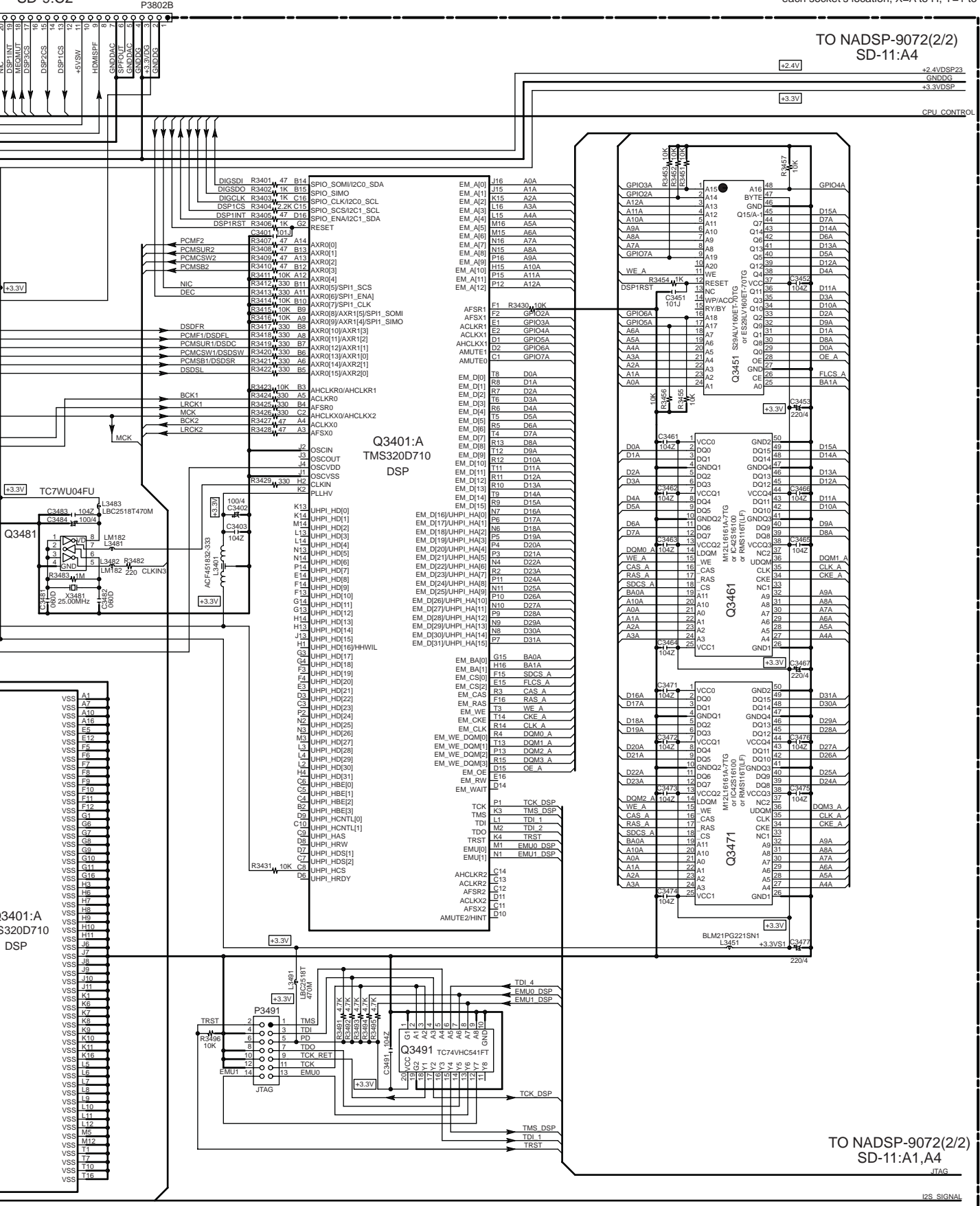

TO NADSP-9072(2/2) SD-11:A4

TO NADSP-9072(2/2) SD-11:A1,A4

I2S SIGNAL

**SCHEMATIC DIAGRAM-11 (SD-11)
DSP SECTION**

NADSP-9072(2/2)

U25 DSP PC BOARD

TO NADSP-9072(1/2)
SD-10:H1
CPU CONTROL

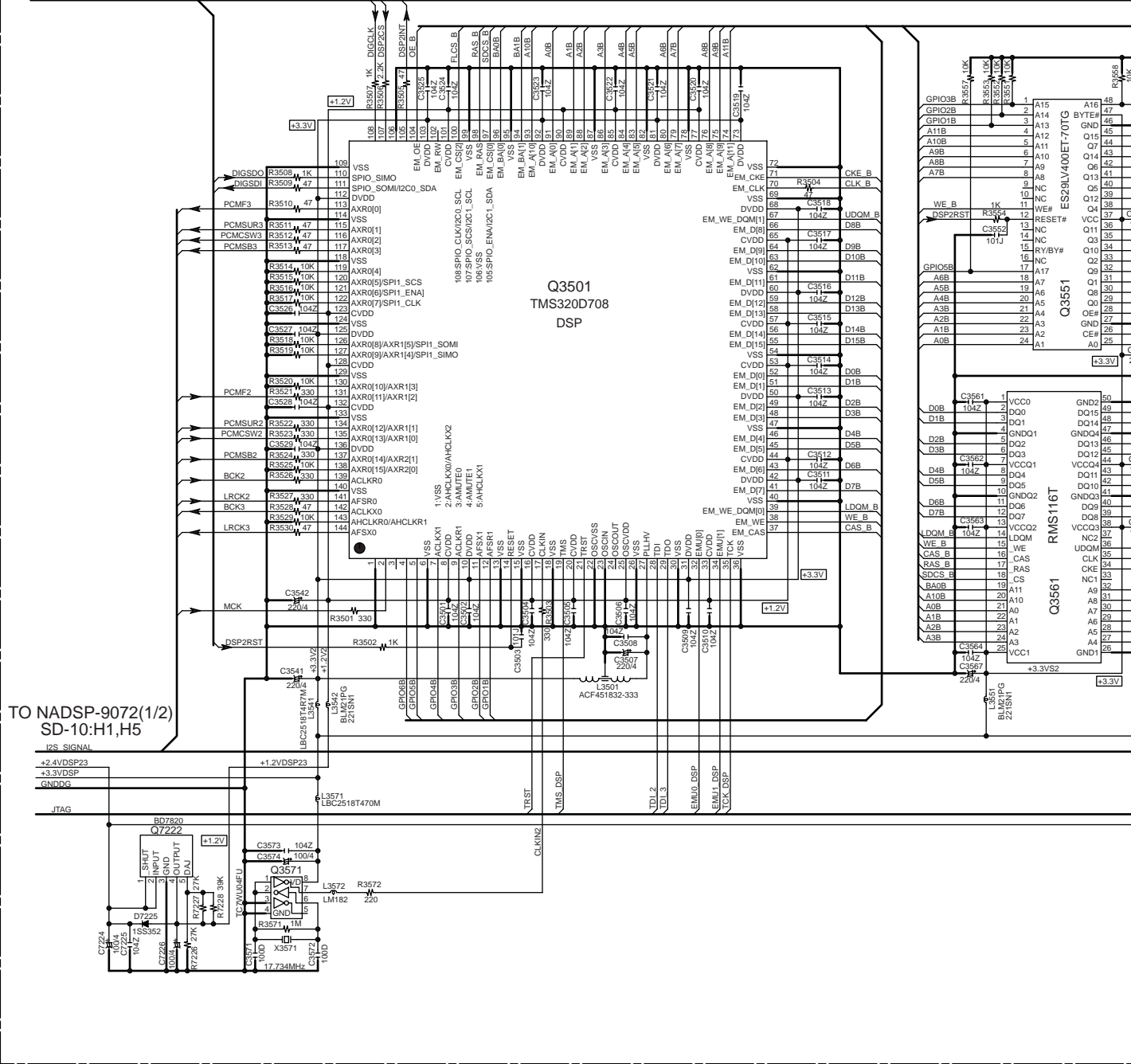

TO NADSP-9072(1/2)
SD-10:H1,H5

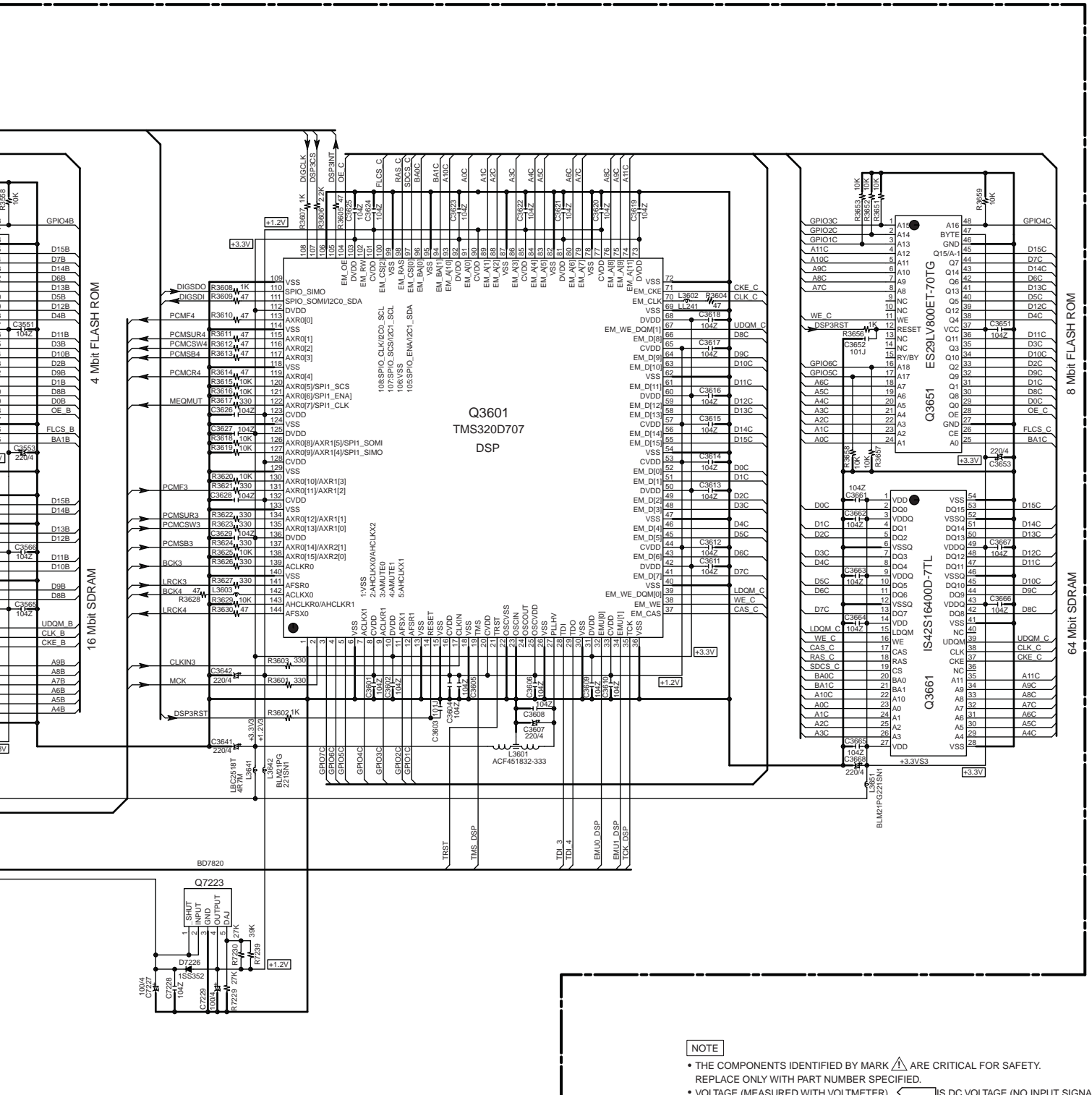

NOTE

- THE COMPONENTS IDENTIFIED BY MARK Δ ARE CRITICAL FOR SAFETY. REPLACE ONLY WITH PART NUMBER SPECIFIED.
- VOLTAGE (MEASURED WITH VOLTMETER) $\langle \rangle$ IS DC VOLTAGE.(NO INPUT SIGNAL).
- ALL PNP TRANSISTORS ARE EQUIVALENT TO 2SA1015-GR UNLESS OTHERWISE NOTED.
- ALL NPN TRANSISTORS ARE EQUIVALENT TO 2SC1815-GR UNLESS OTHERWISE NOTED.
- ALL DIODES ARE EQUIVALENT TO 1SS133 UNLESS OTHERWISE NOTED.
- ELECTROLYTIC CAPACITORS (---) ARE IN $\mu\text{F}/\text{VW}$.
- ALL CAPACITORS ARE IN pF/50WV UNLESS OTHERWISE NOTED.
EX) 030-3pF, 330-33pF, 331-330pF, 333-0.033uF
- ALL RESISTORS ARE IN OHMS 1/4WATTS UNLESS OTHERWISE NOTED.
- THE THICK LINES ON PCB BOARD ARE THE PRINTING SIDE OF THE PARTS.
EX) --- PRINTING SIDE
- CIRCUIT IS SUBJECT TO CHANGE FOR IMPROVEMENT.

<Note>
SD-x:XY is short for Schematic Diagram-x and each socket's location, X=A to H, Y=1 to 5.

A

B

C

D

SCHEMATIC DIAGRAM-12 (SD-12)
XM/SIRIUS SECTION

1

2

3

4

5

NARF-9077

U30 XM PC BOARD

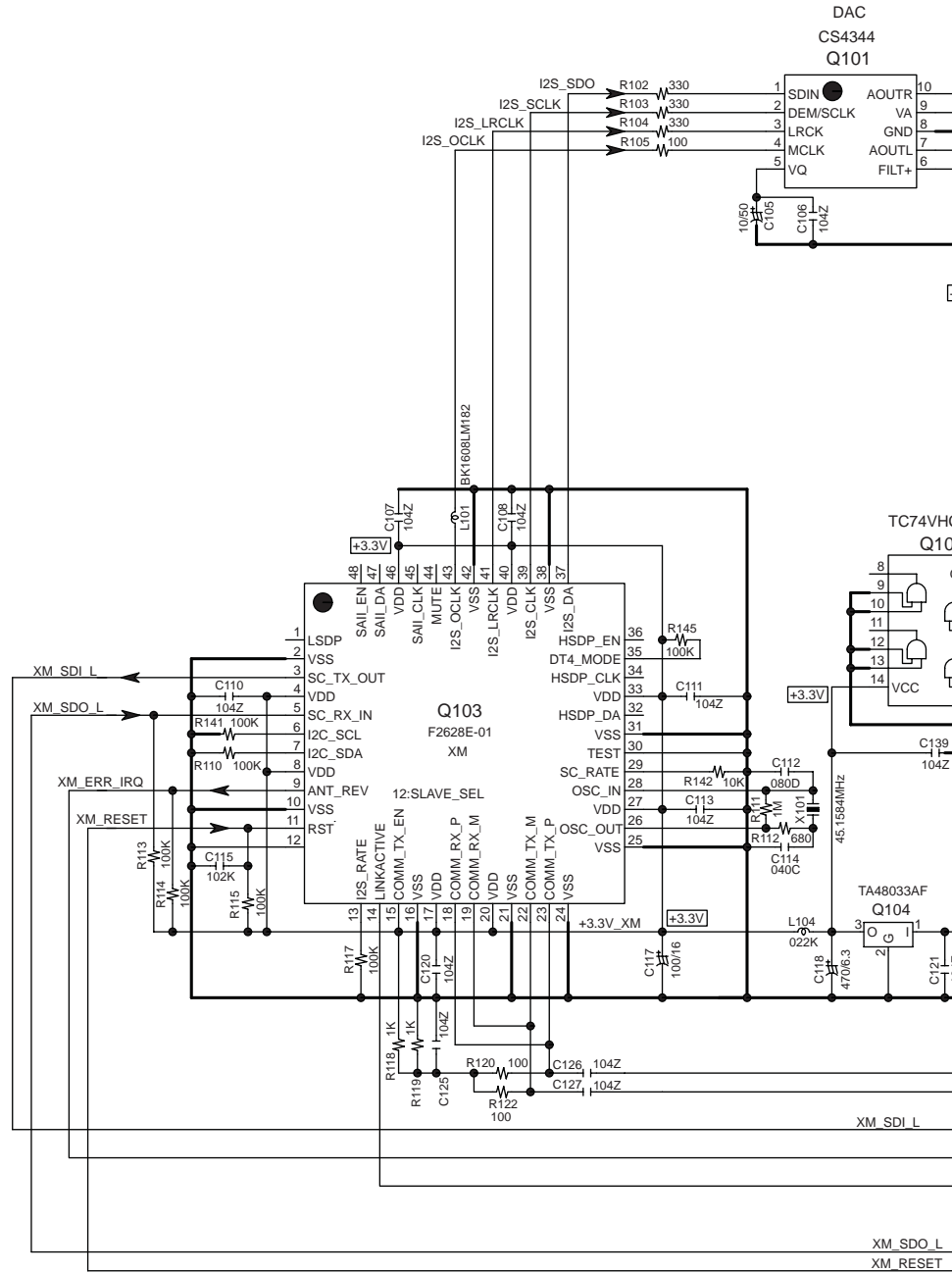

<Note>
SD-x:XY is short for Schematic Diagram-x and
each socket's location, X=A to H, Y=1 to 5.

E

F

G

H

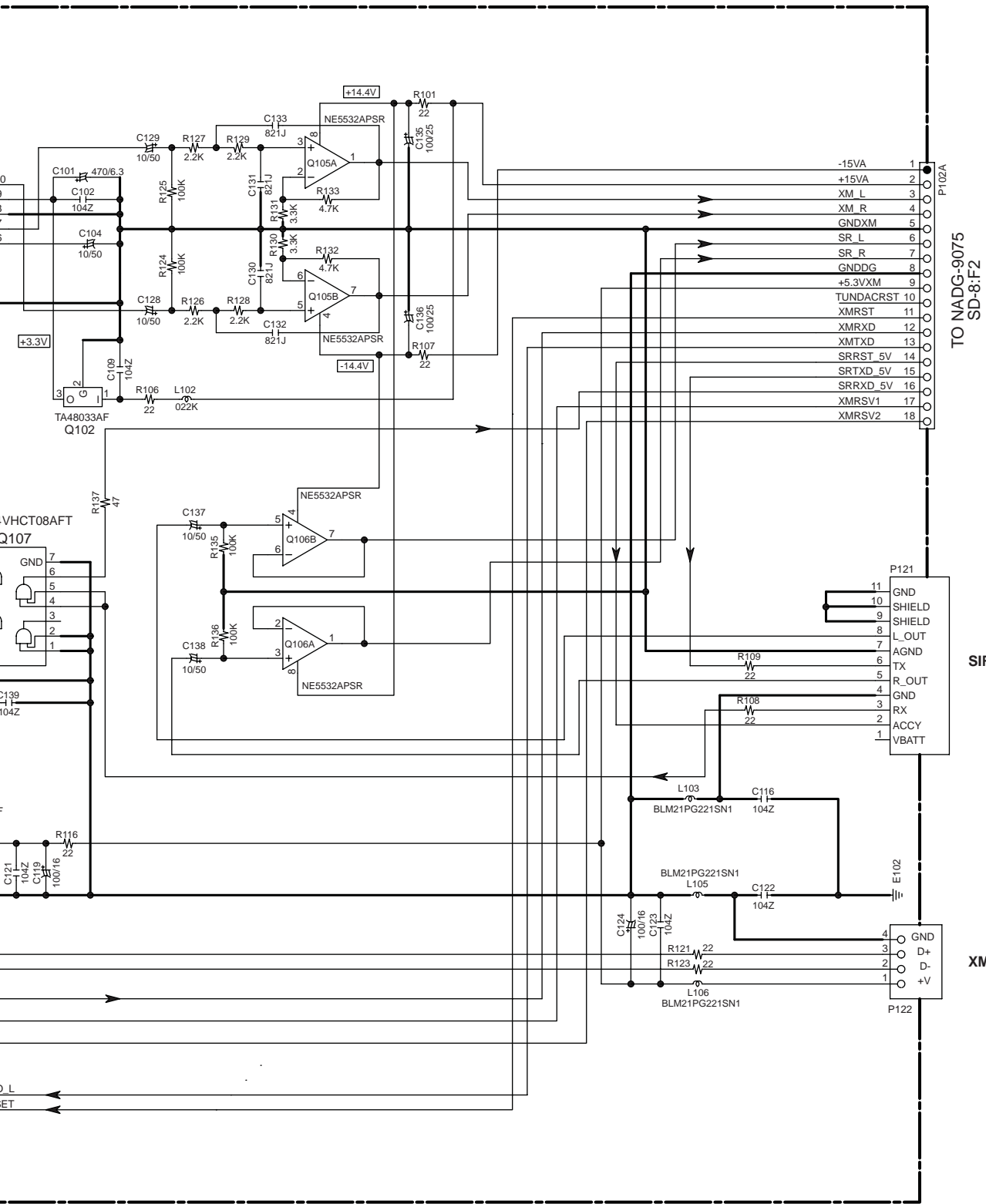

SCHEMATIC DIAGRAM-13 (SD-13) DISPLAY SECTION

NADIS-9085 U33 DISPLAY PC BOARD

TO NADIS-9089
SD-14;G5

TO NADG-9075
SD-8;H2

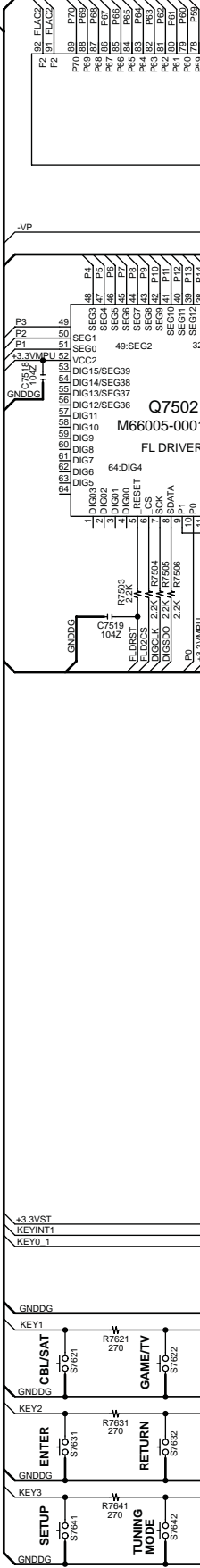

<Note>
SD-x:XY is short for Shematic Diagram-x and each socket's location, X=A to H, Y=1 to 5.

NOTE

- THE COMPONENTS IDENTIFIED BY MARK \triangle ARE CRITICAL FOR SAFETY. REPLACE ONLY WITH PART NUMBER SPECIFIED.
- VOLTAGE (MEASURED WITH VOLTMETER) \square IS DC VOLTAGE. (NO INPUT SIGNAL).
- ALL PNP TRANSISTORS ARE EQUIVALENT TO 2SA1015-GR UNLESS OTHERWISE NOTED.
- ALL NPN TRANSISTORS ARE EQUIVALENT TO 2SC1815-GR UNLESS OTHERWISE NOTED.
- ALL DIODES ARE EQUIVALENT TO 1SS133 UNLESS OTHERWISE NOTED.
- ELECTROLYTIC CAPACITORS (---) ARE IN μ F/VV.
- ALL CAPACITORS ARE IN pF/50V UNLESS OTHERWISE NOTED.
- EX) 030- 3pF, 330- 33pF, 331- 330pF, 333- 0.033 μ F
- ALL RESISTORS ARE IN OHMS 1/4WATTS UNLESS OTHERWISE NOTED.
- THE THICK LINES ON PC BOARD ARE THE PRINTING SIDE OF THE PARTS.
- EX) \square PRINTING SIDE
- CIRCUIT IS SUBJECT TO CHANGE FOR IMPROVEMENT.

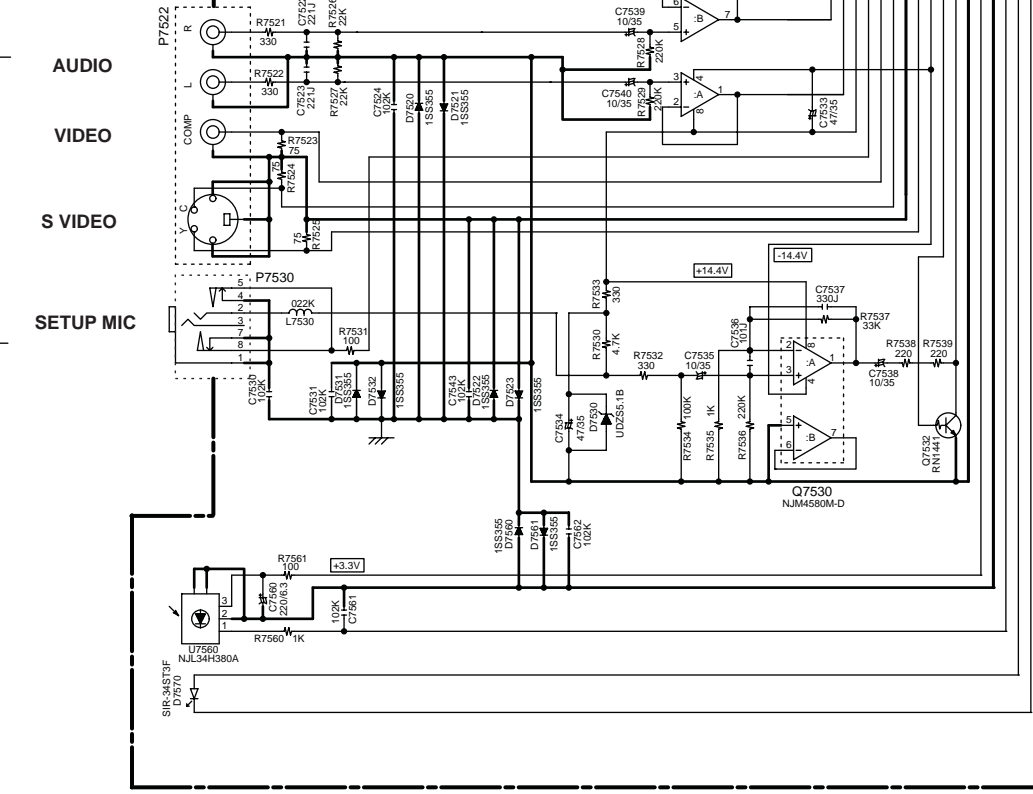
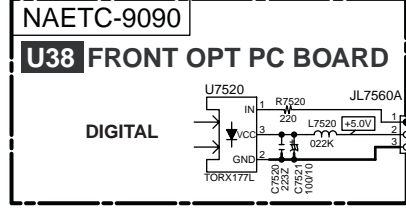

1

2

3

4

5

E

F

G

H

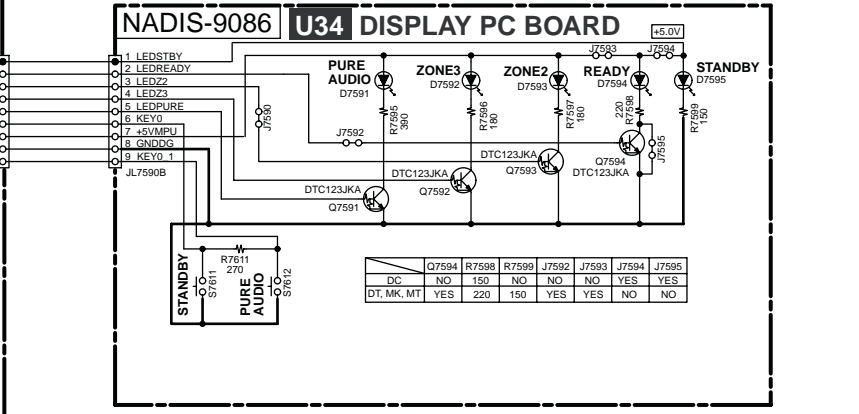
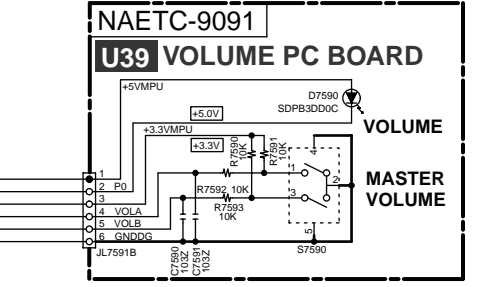
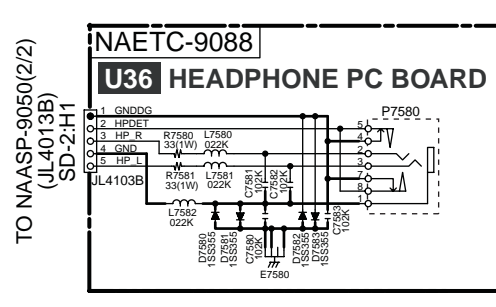
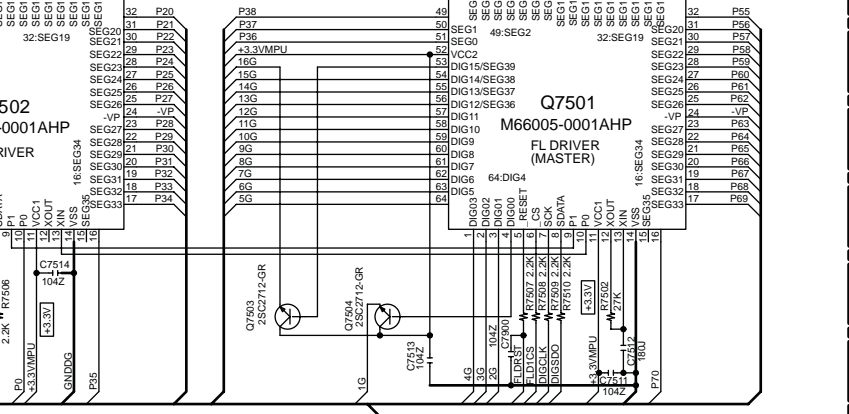
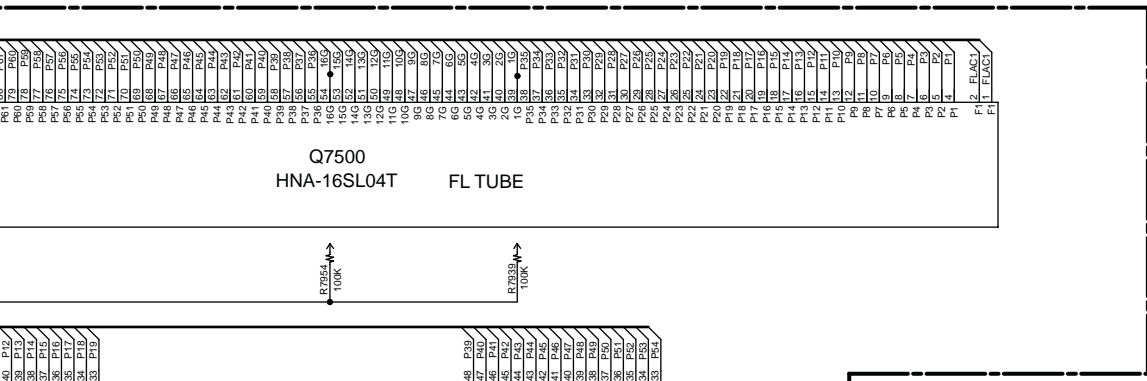

SELECTOR KEYS

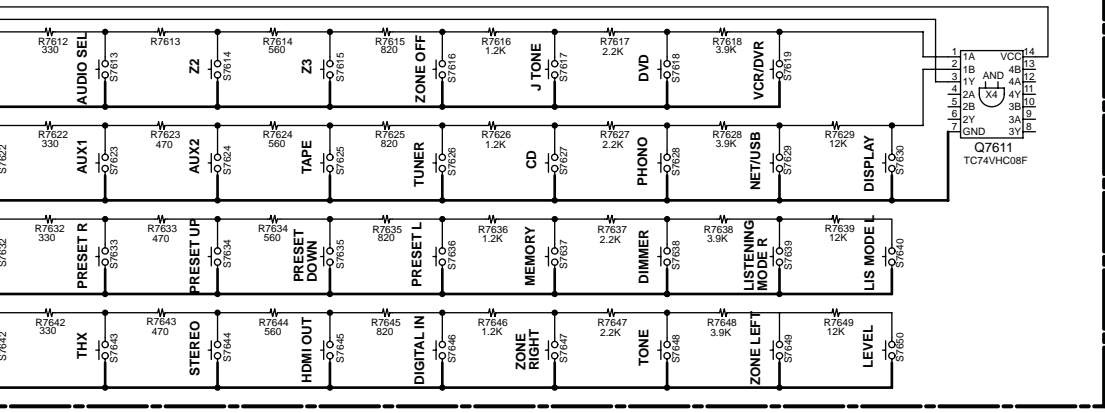

SCHEMATIC DIAGRAM-14 (SD-14)
POWER SUPPLY SECTION

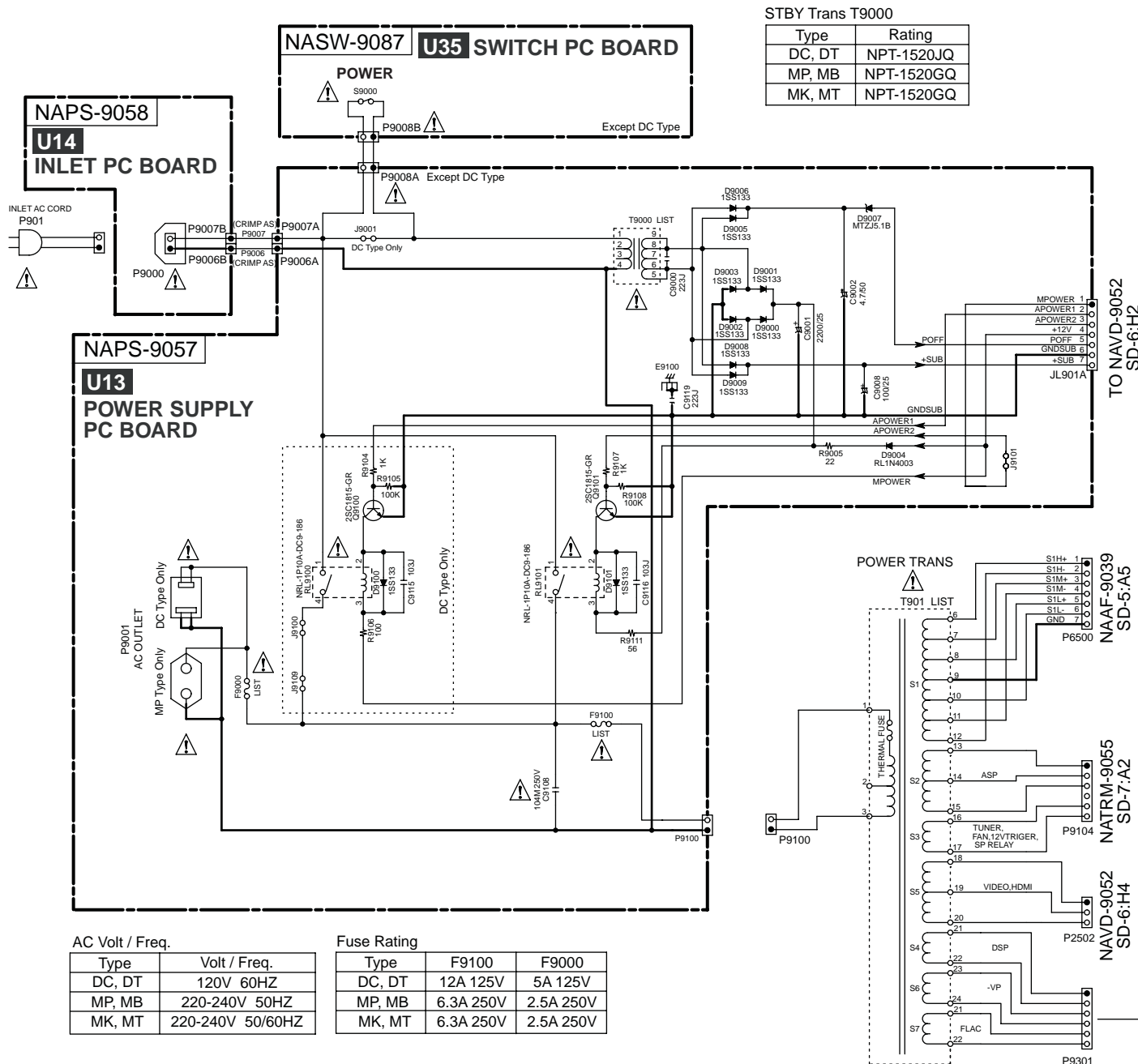

STBY Trans T9000

Type	Rating
DC, DT	NPT-1520JQ
MP, MB	NPT-1520GQ
MK, MT	NPT-1520GQ

AC Volt / Freq.		Fuse Rating		
Type	Volt / Freq.	Type	F9100	F9000
DC, DT	120V 60HZ	DC, DT	12A 125V	5A 125V
MP, MB	220-240V 50HZ	MP, MB	6.3A 250V	2.5A 250V
MK, MT	220-240V 50/60HZ	MK, MT	6.3A 250V	2.5A 250V

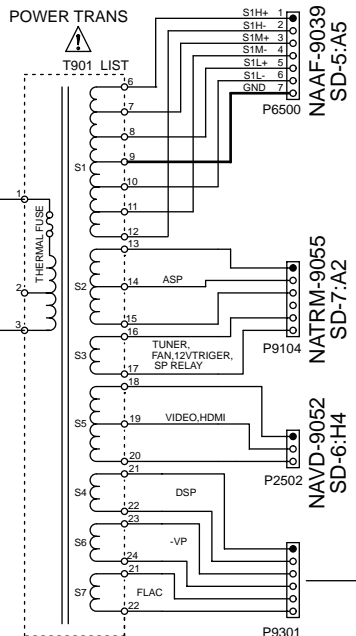

Power Trans T901

Type	Rating
DC, DT	NPT-1553D
MP, MB	NPT-1553M
MK, MT	NPT-1553M

<Note>
SD-x:XY is short for Schematic Diagram-x and each socket's location, X=A to H, Y=1 to 5.

- NOTE
- THE COMPONENTS IDENTIFIED BY MARK ⚠ ARE CRITICAL FOR SAFETY. REPLACE ONLY WITH PART NUMBER SPECIFIED.
 - VOLTAGE (MEASURED WITH VOLTMETER) ◀ IS DC VOLTAGE. (NO INPUT SIGNAL).
 - ALL PNP TRANSISTORS ARE EQUIVALENT TO 2SA1015-GR UNLESS OTHERWISE NOTED.
 - ALL NPN TRANSISTORS ARE EQUIVALENT TO 2SC1815-GR UNLESS OTHERWISE NOTED.
 - ALL DIODES ARE EQUIVALENT TO 1SS133 UNLESS OTHERWISE NOTED.
 - ELECTROLYTIC CAPACITORS (⚡) ARE IN uF/WV.
 - ALL CAPACITORS ARE IN pF/50V UNLESS OTHERWISE NOTED.
EX) 030- 3pF, 330- 33pF, 331- 330pF, 333- 0.033uF
 - ALL RESISTORS ARE IN OHMS 1/4WATTS UNLESS OTHERWISE NOTED.
 - THE THICK LINES ON PC BOARD ARE THE PRINTING SIDE OF THE PARTS.
EX) PRINTING SIDE
 - CIRCUIT IS SUBJECT TO CHANGE FOR IMPROVEMENT.

1

2

3

4

5

TO NAVD-9052 SD-6:H2

NAAF-9039 SD-5:A5

NATRM-9055 SD-7:A2

NAVD-9052 SD-6:H4



CAUTION

FOR CONTINUED PROTECTION AGAINST FIRE HAZARD, REPLACE ONLY WITH FUSE OF SAME TYPE AND RATING INDICATED.



ATTENTION

AFIN D'ASSURER UNE PROTECTION PERMANENTE CONTRE LES RISQUES D'INCENDIE, REMPLACER UNIQUEMENT PAR UN FUSIBLE DE MEME TYPE ET CALIBRATION COMME INDIQUE.



THIS SYMBOL LOCATED NEAR THE FUSE INDICATES THAT THE FUSE USED IS SLOW OPERATING TYPE FOR CONTINUED PROTECTION AGAINST FIRE FUSE HAZARD, REPLACE WITH SAME TYPE FUSE. FOR FUSE RATING REFER TO THE MAKING ADJACENT TO THE SYMBOL.



CE SYMBOLE INDIQUE QUE LE FUSIBLE UTILISE EST A LENT, E POUR UNE PROTECTION PERMANENTE, N'UTILISER QUE DES FUSIBLES DE MEME TYPE. CE DERNIER EST INDIQUE LA QU LE PRESENT SYMBOLE EST APPOSE.

TO NAASP-9050(2/2)
SD-2:A3

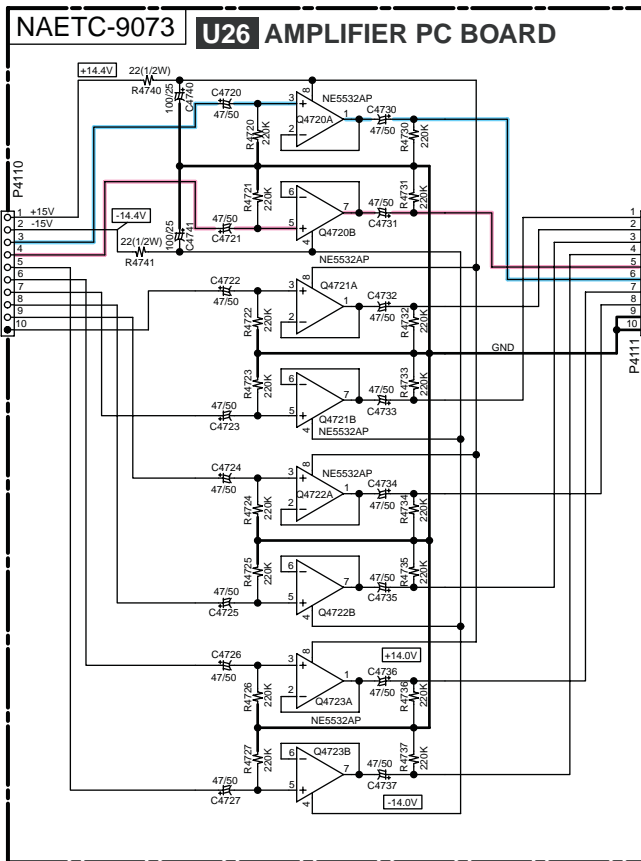

TO NAASP-9050(2/2)
SD-2:A3

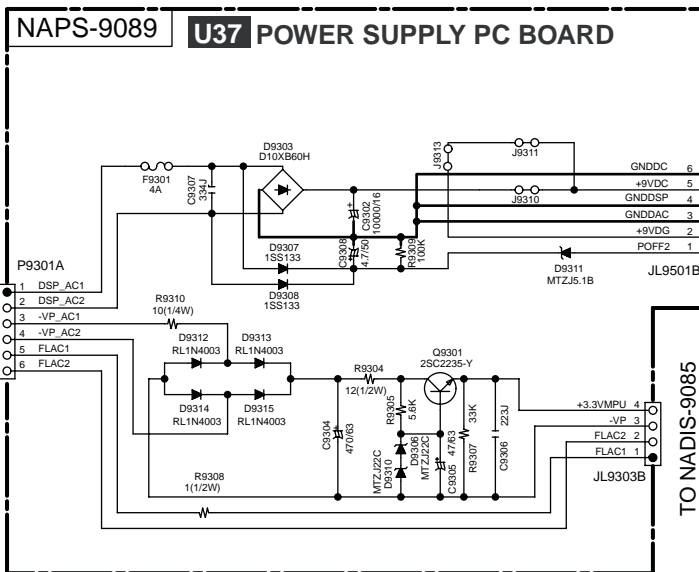

TO NADIS-9085
SD-13:B1

TO NADG-9074
SD-9:H4

SCHEMATIC DIAGRAM-15 (SD-15)

HDMI SECTION-1

NAHDM-9114(1/5) U42 HDMI PC BOARD

VX-50 VIDEO SIGNAL I/O PART

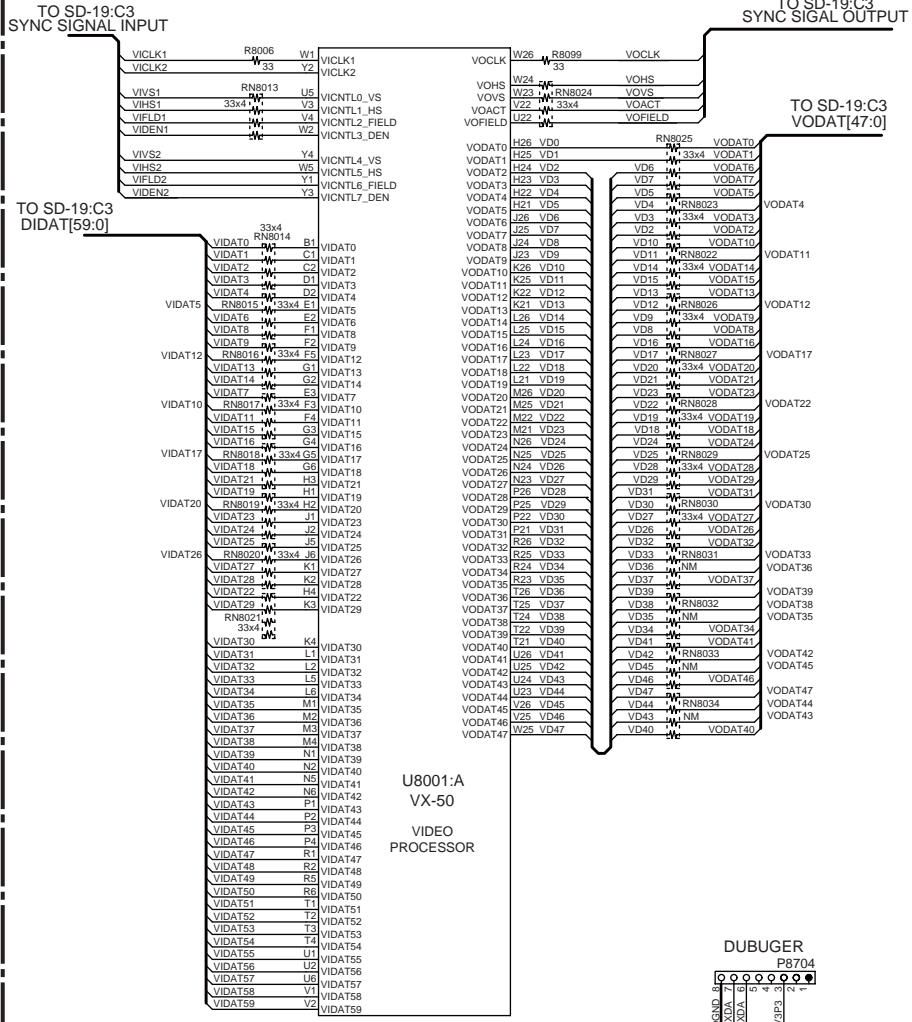

VX-50 FLAS...

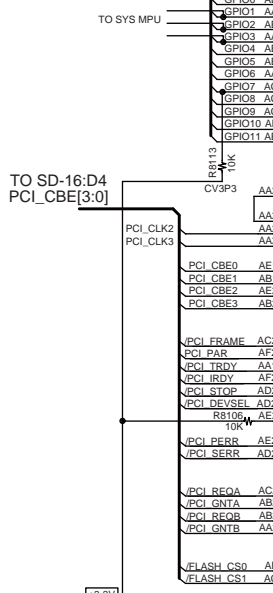

VX-50 JTAG PART

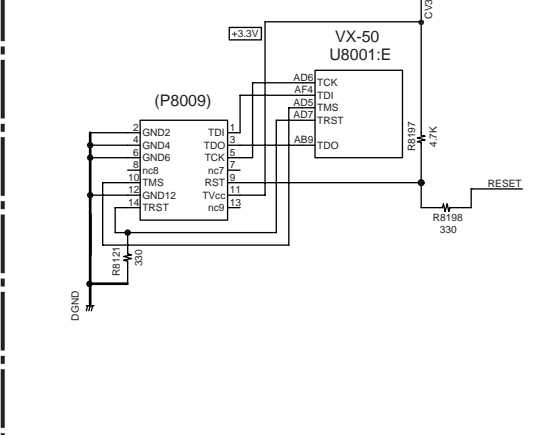

DUBUGER P8704



VX-50 MPU I/O PART

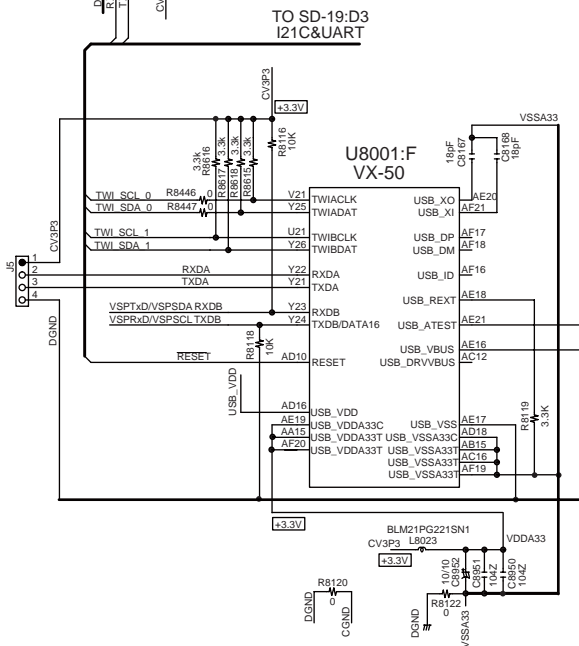

1

2

3

4

5

E

F

G

H

CASH MEMORY I/O PART

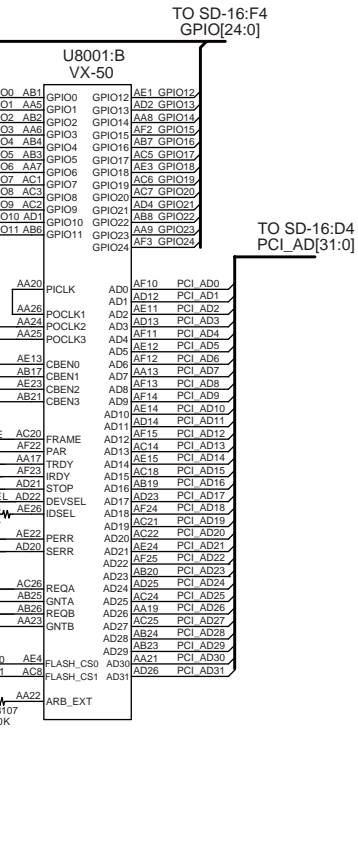

VX-50 POWER SUPPLY & GROUND PART

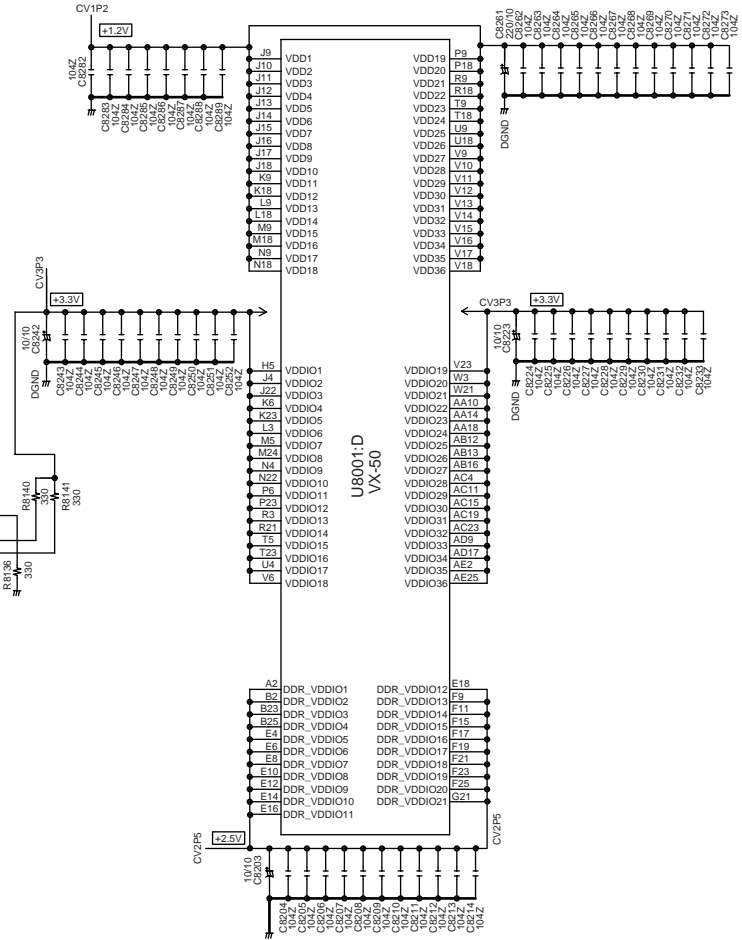

VX-50 OSC&PLL PART

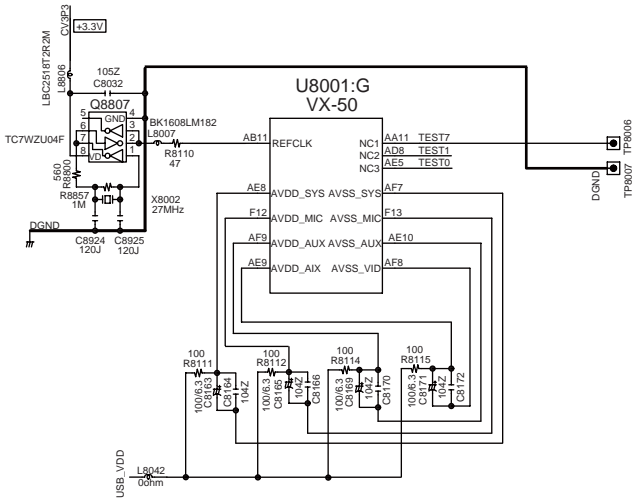

<Note>
SD-x:XY is short for Schematic Diagram-x and each socket's location, X=A to H, Y=1 to 5.

- NOTE
- THE COMPONENTS IDENTIFIED BY MARK ARE CRITICAL FOR SAFETY. REPLACE ONLY WITH PART NUMBER SPECIFIED.
 - VOLTAGE (MEASURED WITH VOLTMETER) IS DC VOLTAGE (NO INPUT SIGNAL).
 - ALL PNP TRANSISTORS ARE EQUIVALENT TO 2SA1015-GR UNLESS OTHERWISE NOTED.
 - ALL NPN TRANSISTORS ARE EQUIVALENT TO 2SC1815-GR UNLESS OTHERWISE NOTED.
 - ALL DIODES ARE EQUIVALENT TO 1SS133 UNLESS OTHERWISE NOTED.
 - ELECTROLYTIC CAPACITORS () ARE IN uF/WV.
 - ALL CAPACITORS ARE IN pF/50VWV UNLESS OTHERWISE NOTED.
EX) 030-3pF, 330-33pF, 331-330pF, 333-0.033uF
 - ALL RESISTORS ARE IN OHMS 1/4WATTS UNLESS OTHERWISE NOTED.
 - THE THICK LINES ON PC BOARD ARE THE PRINTING SIDE OF THE PARTS.
EX) PRINTING SIDE
 - CIRCUIT IS SUBJECT TO CHANGE FOR IMPROVEMENT.

A

B

C

D

SCHEMATIC DIAGRAM-16 (SD-16)
HDMI SECTION-2

NAHDM-9114(2/5) U42 HDMI PC BOARD

1

2

3

4

5

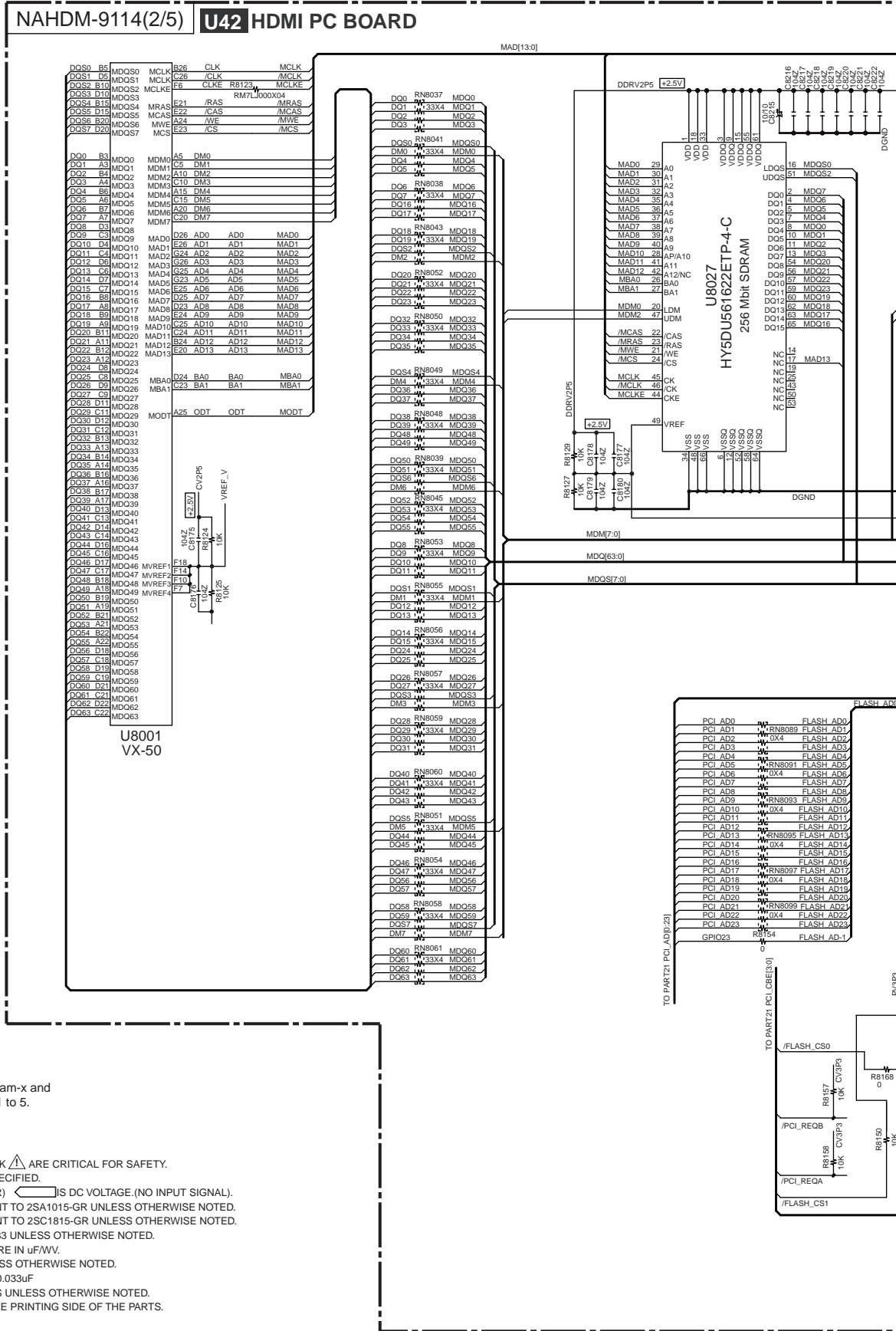

<Note>
SD-x:XY is short for Schematic Diagram-x and
each socket's location, X=A to H, Y=1 to 5.

NOTE

- THE COMPONENTS IDENTIFIED BY MARK \triangle ARE CRITICAL FOR SAFETY. REPLACE ONLY WITH PART NUMBER SPECIFIED.
- VOLTAGE (MEASURED WITH VOLTMETER) \square IS DC VOLTAGE.(NO INPUT SIGNAL).
- ALL PNP TRANSISTORS ARE EQUIVALENT TO 2SA1015-GR UNLESS OTHERWISE NOTED.
- ALL NPN TRANSISTORS ARE EQUIVALENT TO 2SC1815-GR UNLESS OTHERWISE NOTED.
- ALL DIODES ARE EQUIVALENT TO 1SS133 UNLESS OTHERWISE NOTED.
- ELECTROLYTIC CAPACITORS (---) ARE IN μ F/VV.
- ALL CAPACITORS ARE IN pF/50WV UNLESS OTHERWISE NOTED.
EX) 030- 3pF, 330- 33pF, 331- 330pF, 333- 0.033 μ F
- ALL RESISTORS ARE IN OHMS 1/4WATTS UNLESS OTHERWISE NOTED.
- THE THICK LINES ON PC BOARD ARE THE PRINTING SIDE OF THE PARTS.
EX) \square PRINTING SIDE
- CIRCUIT IS SUBJECT TO CHANGE FOR IMPROVEMENT.

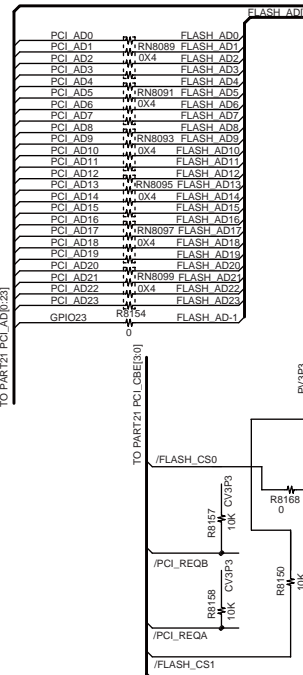

E

F

G

H

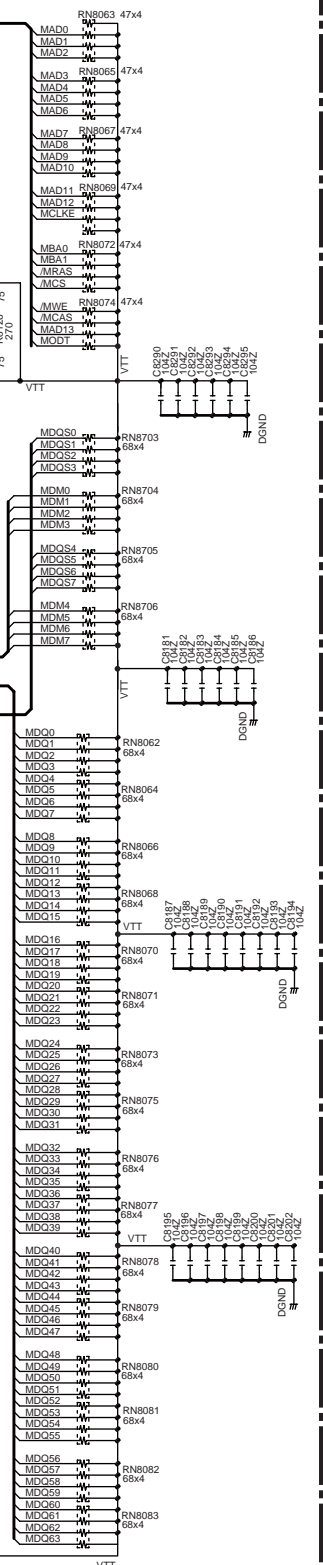
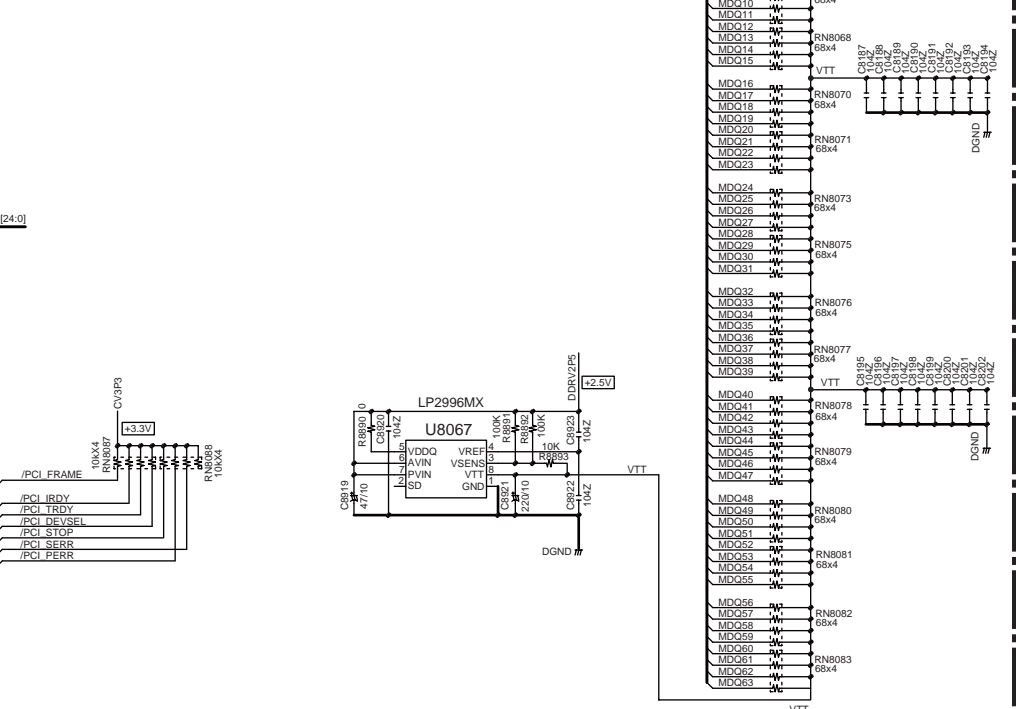
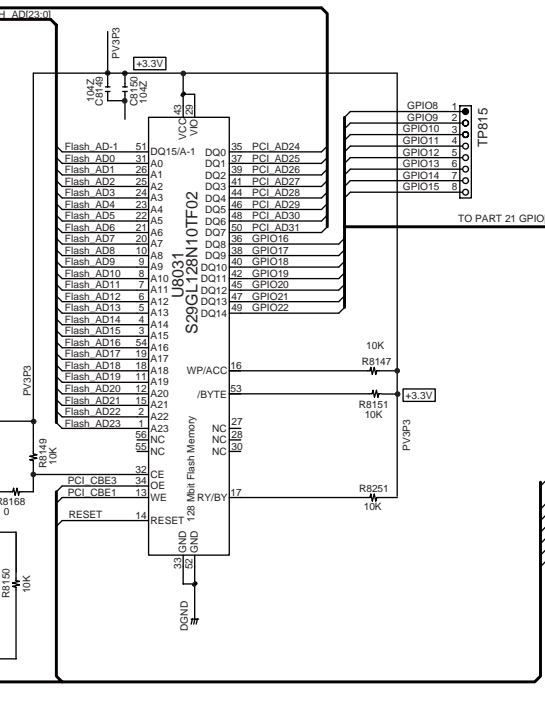
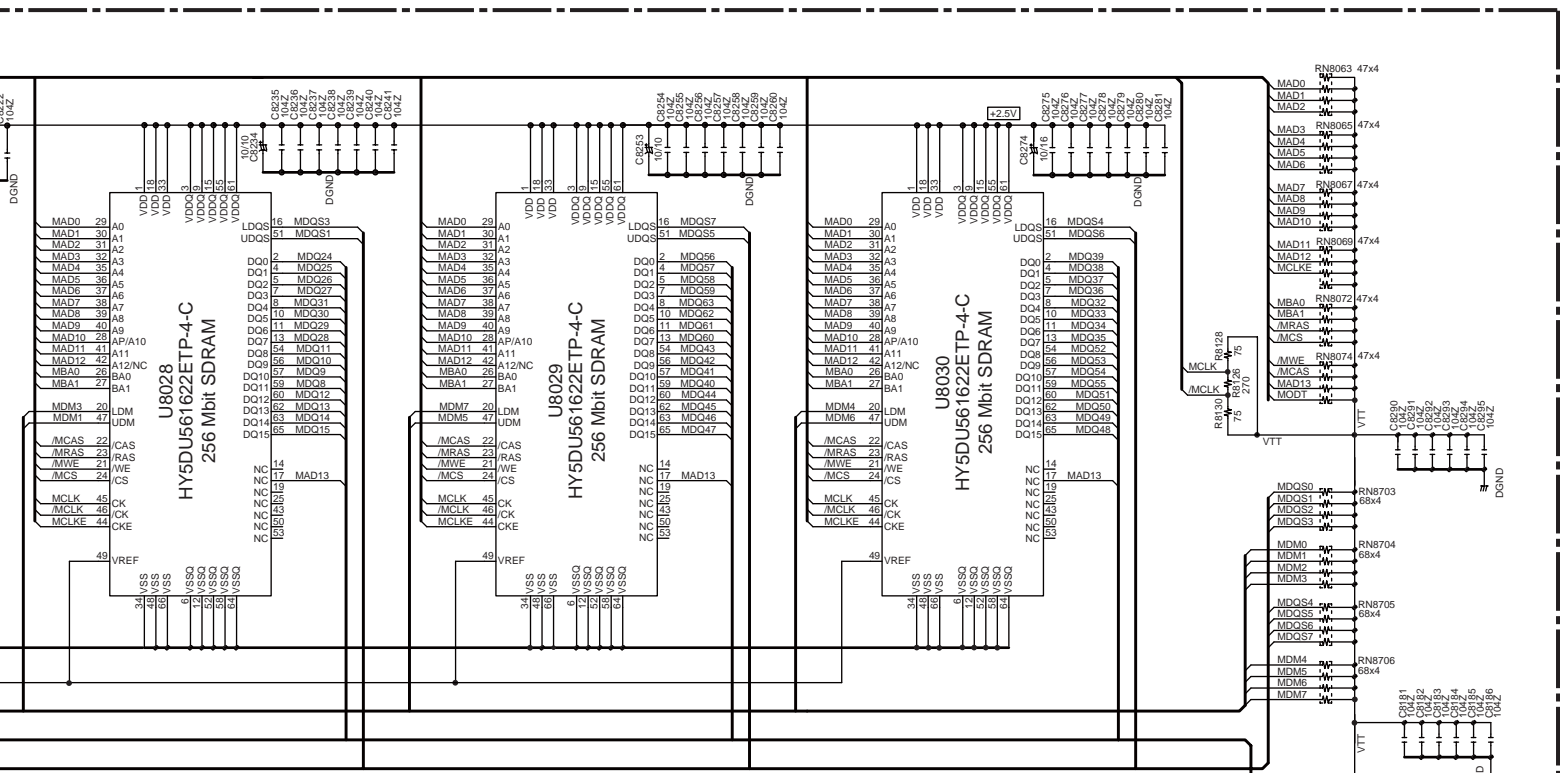

A

B

C

D

SCHEMATIC DIAGRAM-17 (SD-17) HDMI SECTION-3

1

2

3

4

5

NAHDM-9114(3/5) U42 HDMI PC BOARD

HDMI IN4

HDMI IN3

HDMI IN2

HDMI IN1

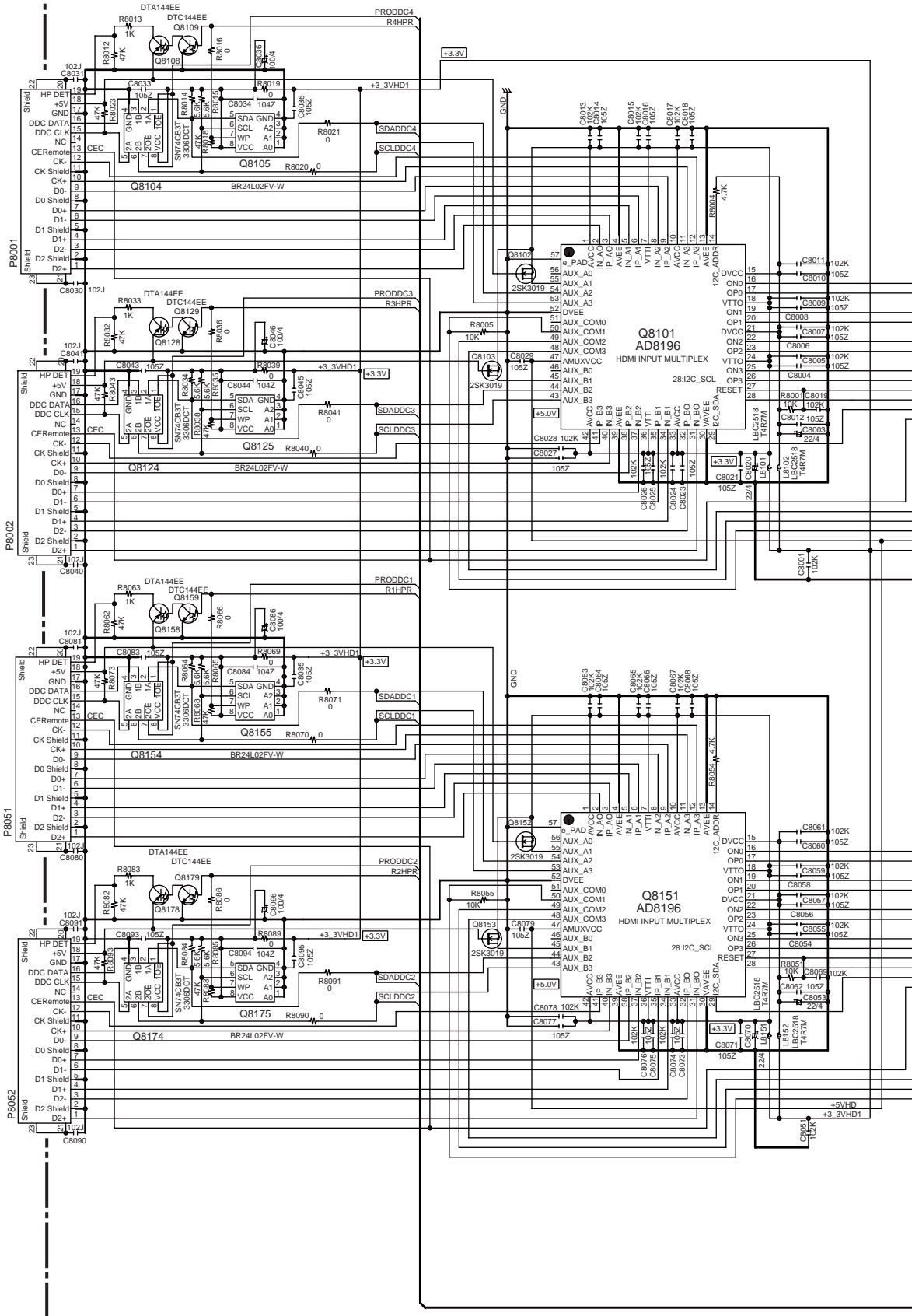

E

F

G

H

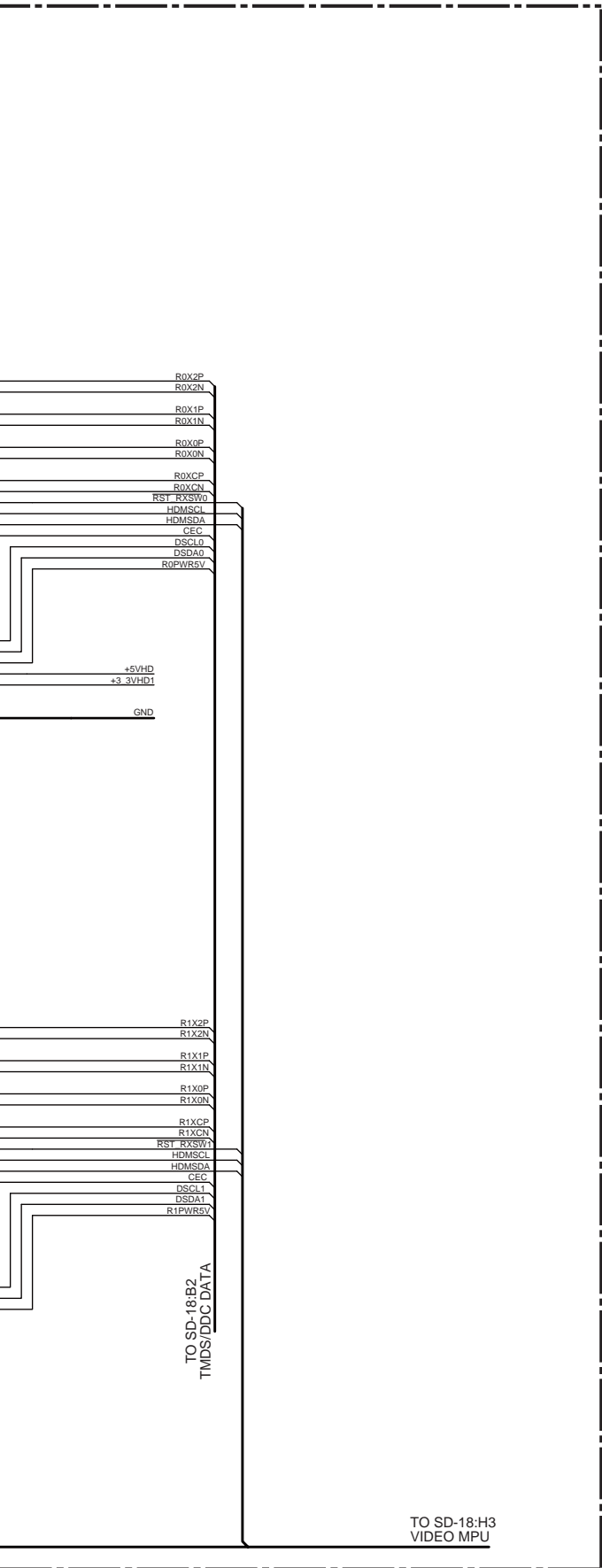

<Note>
SD-x:XY is short for Shcematic Diagram-x and each socket's location, X=A to H, Y=1 to 5.

NOTE

- THE COMPONENTS IDENTIFIED BY MARK \triangle ARE CRITICAL FOR SAFETY. REPLACE ONLY WITH PART NUMBER SPECIFIED.
- VOLTAGE (MEASURED WITH VOLTMETER) $\langle \text{---} \rangle$ IS DC VOLTAGE.(NO INPUT SIGNAL).
- ALL PNP TRANSISTORS ARE EQUIVALENT TO 2SA1015-GR UNLESS OTHERWISE NOTED.
- ALL NPN TRANSISTORS ARE EQUIVALENT TO 2SC1815-GR UNLESS OTHERWISE NOTED.
- ALL DIODES ARE EQUIVALENT TO 1SS133 UNLESS OTHERWISE NOTED.
- ELECTROLYTIC CAPACITORS ($\text{---} \text{---} \text{---}$) ARE IN uF/WV.
- ALL CAPACITORS ARE IN pF/50WV UNLESS OTHERWISE NOTED.
EX) 030- 3pF, 330- 33pF, 331- 330pF, 333- 0.033uF
- ALL RESISTORS ARE IN OHMS 1/4WATTS UNLESS OTHERWISE NOTED.
- THE THICK LINES ON PC BOARD ARE THE PRINTING SIDE OF THE PARTS.
EX) $\text{---} \text{---} \text{---}$ PRINTING SIDE
- CIRCUIT IS SUBJECT TO CHANGE FOR IMPROVEMENT.

A

B

C

D

SCHEMATIC DIAGRAM-18 (SD-18) HDMI SECTION-4

NAHDM-9114(4/5)

U42 HDMI PC BOARD

1

2

3

4

5

TO SD-17:E5
TMDS/DDC DATA

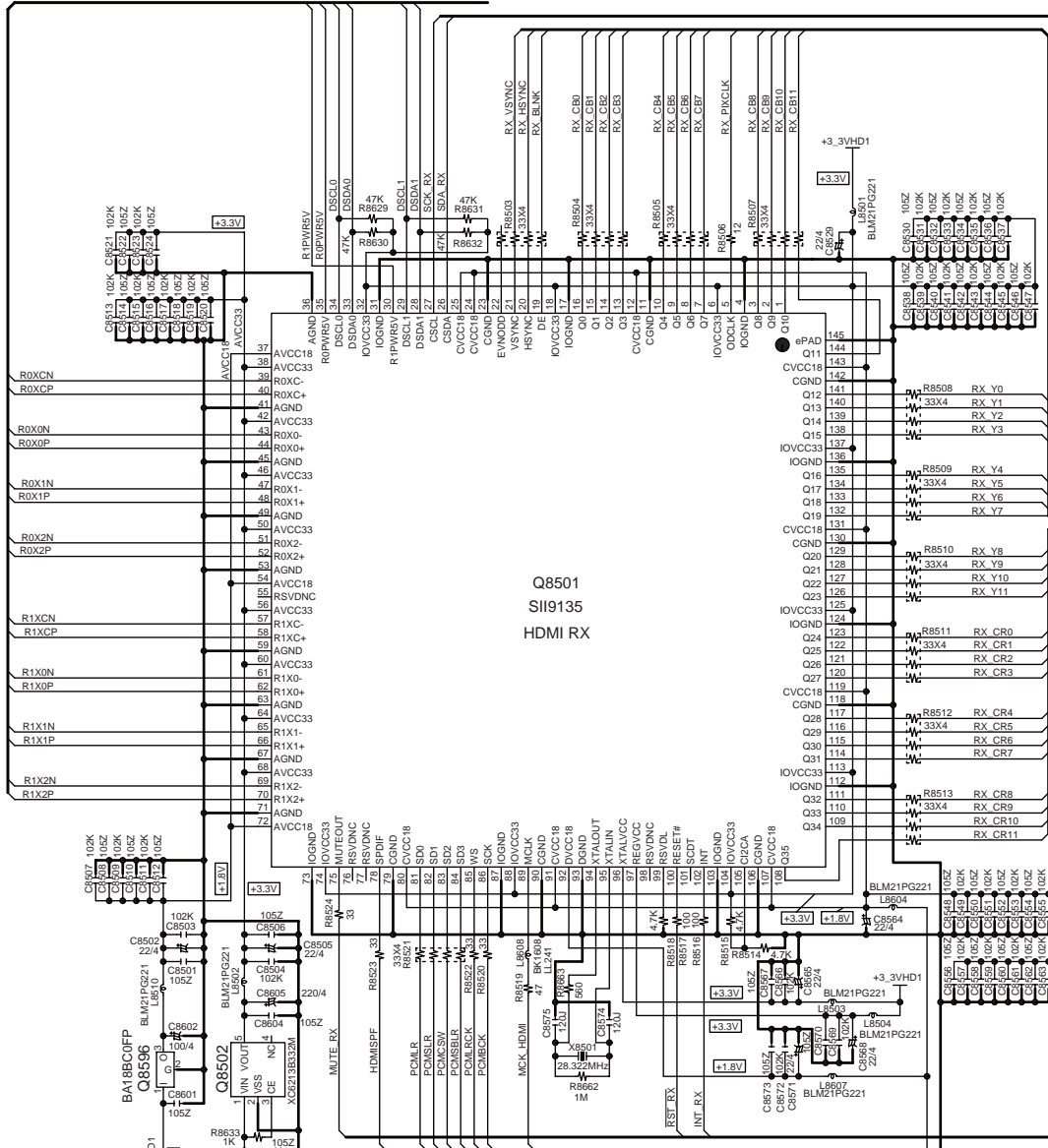

Q8501
SiI9135
HDMI RX

TO SD-19
DIGITAL VIDEO
RX[Y, CB, CR

TO PART25 DIGITAL AUDIO DATA

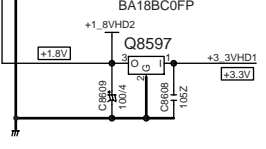

<Note>
SD-x:XY is short for Schematic Diagram-x and each socket's location, X=A to H, Y=1 to 5.

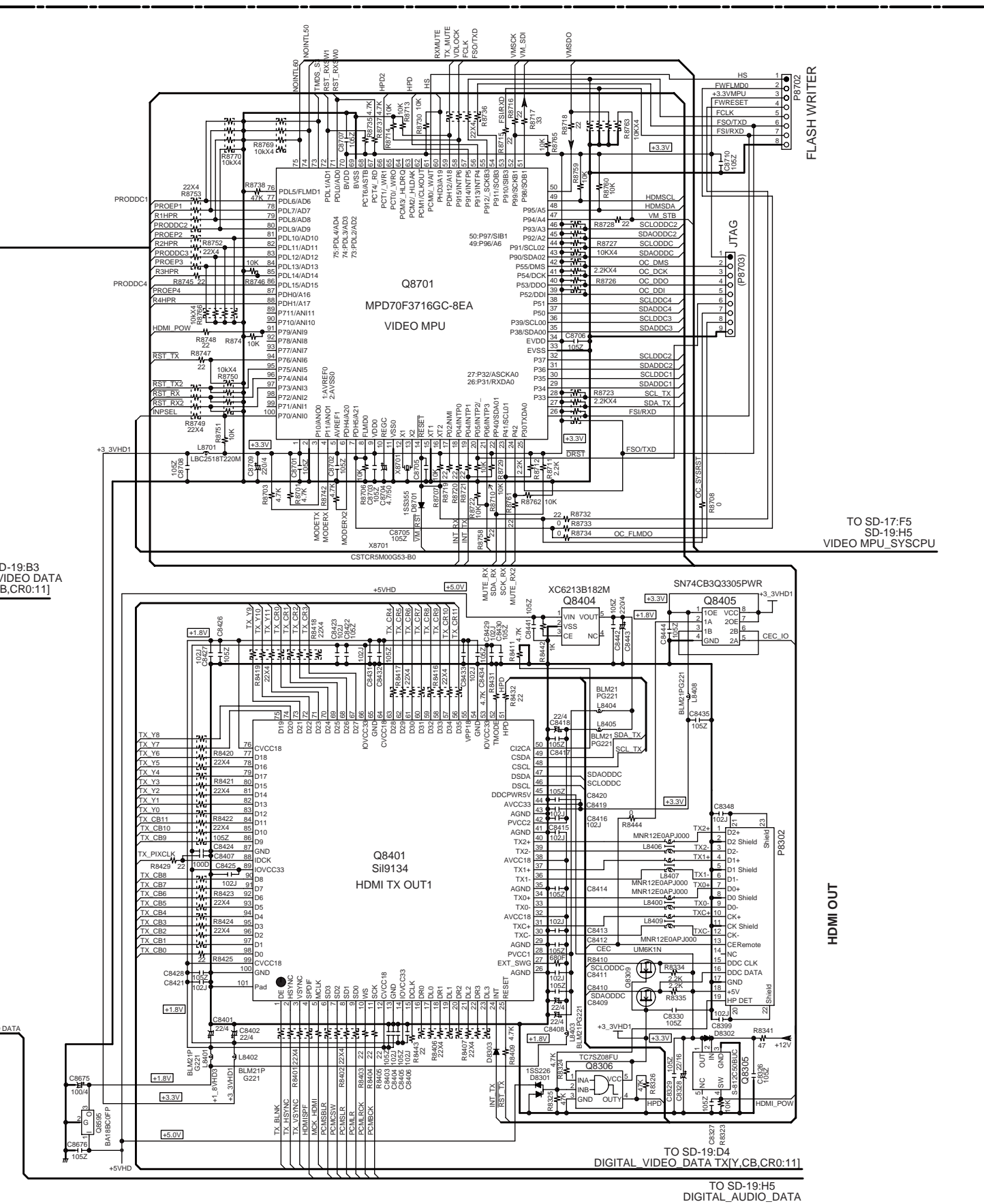

FLASH WRITER

JTAG

TO SD-17:F5
SD-19:H5
VIDEO MPU_SYSCPU

HDMI OUT

TO SD-19:D4
DIGITAL_VIDEO_DATA TXIY.CB.CR0:11

TO SD-19:H5
DIGITAL_AUDIO_DATA

D-19:B3
VIDEO DATA
B.CR0:11

DATA

SCHEMATIC DIAGRAM-19 (SD-19) HDMI SECTION-5

A

B

C

D

NAHDM-9114(5/5)
U42 HDMI PC BOARD

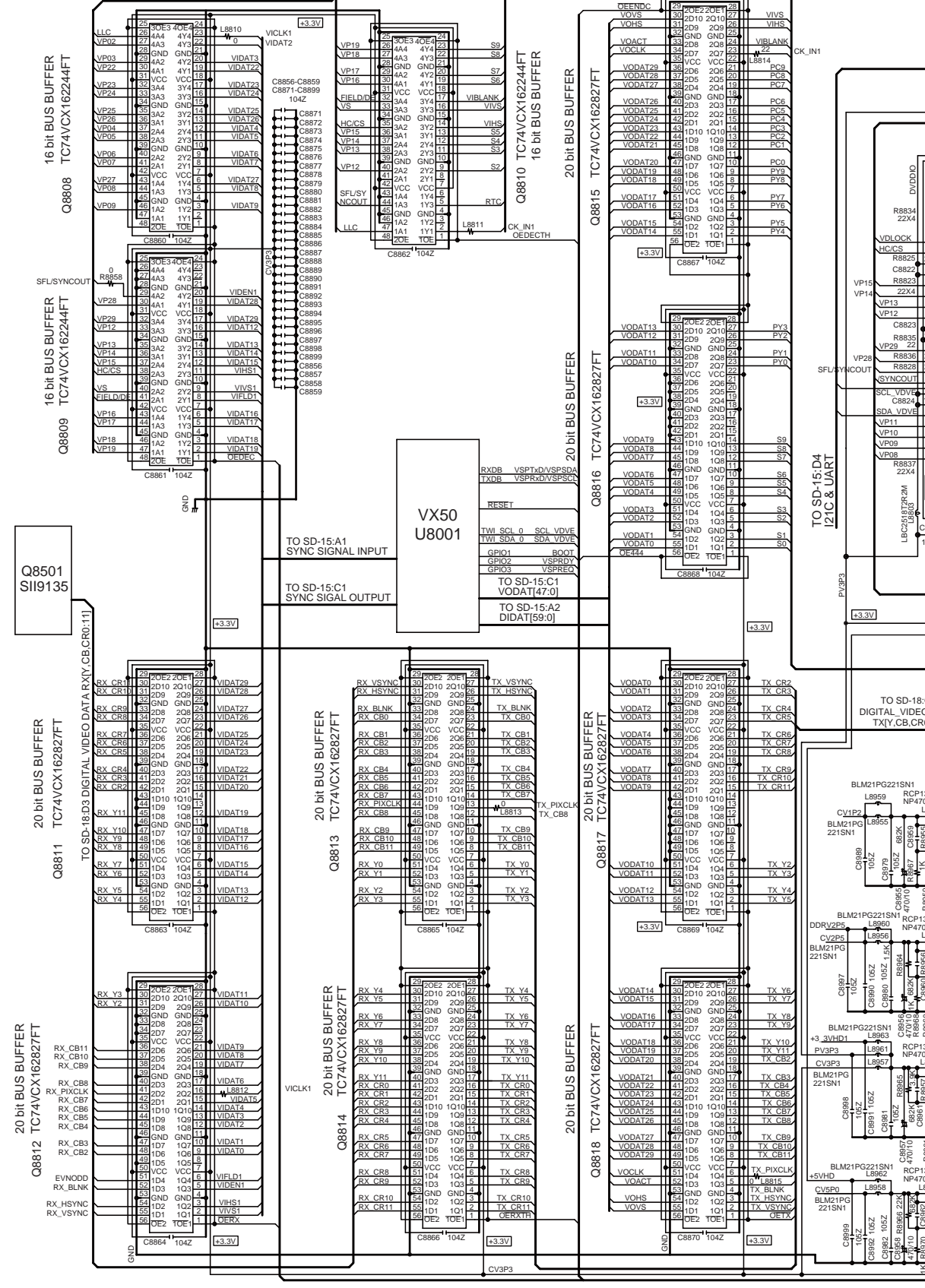

1

2

3

4

5

<Note>
SD-x:XY is short for Schematic Diagram-x and each socket's location, X=A to H, Y=1 to 5.

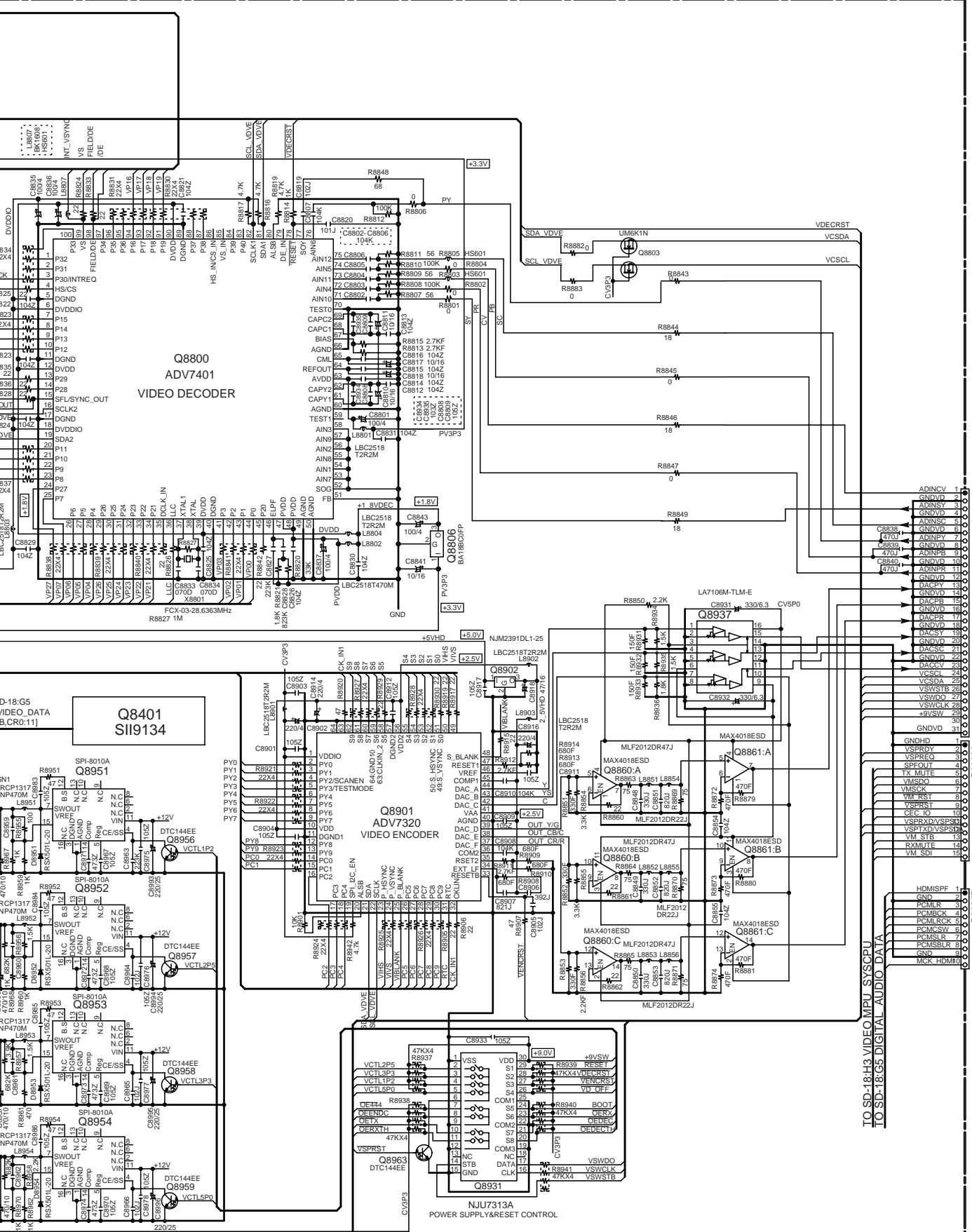

TO NAVD-9052
SD-6:F2

TO NAAR-9075
SD-8:G1

TO NADSP-9072
SD-10:B1

TO SD-18:H3 VIDEO MPU SYSCPU
TO SD-18:G5 DIGITAL AUDIO DATA

P2801B

P8002A

P3803B

POWER SUPPLY & RESET CONTROL