

ONKYO® SERVICE MANUAL

Audio Video Control Receiver MODEL TX-SV343



Black model

BMDN/BMDC	120V AC, 60Hz
BMP/BMPT	230V AC, 50Hz
BMGK/BMWT	120V/220V-230V 50Hz/60Hz
BMPA	220V AC, 60Hz

SAFETY-RELATED COMPONENT WARNING!!

COMPONENTS IDENTIFIED BY MARK Δ ON THE SCHEMATIC DIAGRAM AND IN THE PARTS LIST ARE CRITICAL FOR RISK OF FIRE AND ELECTRIC SHOCK. REPLACE THESE COMPONENTS WITH ONKYO PARTS WHOSE PARTS NUMBERS APPEAR AS SHOWN IN THIS MANUAL.

MAKE LEAKAGE-CURRENT OR RESISTANCE MEASUREMENTS TO DETERMINE THAT EXPOSED PARTS ARE ACCEPTABLY INSULATED FROM THE SUPPLY CIRCUIT BEFORE RETURNING THE APPLIANCE TO THE CUSTOMER.

CONTENTS

SPECIFICATIONS 2
 SERVICE PROCEDURES 3
 EXPLODED VIEW 4
 PARTS LIST 5
 BLOCK DIAGRAMS 6
 MICROPROCESSOR CONNECTION DIAGRAM 8
 MICROPROCESSOR TERMINAL DESCRIPTION..... 9
 IC BLOCK DIAGRAMS AND DESCRIPTION 10
 PACKING VIEW /PARTS LIST..... 15
 ADJUSTMENT PROCEDURES16
 PRINTED CIRCUIT BOARD VIEWFROM BOTTOM SIDE 19
 PRINTED CIRCUIT BOARD-PARTS LIST 25
 SCHEMATIC DIAGRAMS 29



SPECIFICATIONS

TX-SV343

AMPLIFIER SECTION

Power Output

USA & Canadian models: Stereo Mode
60 watts per channel, min. RMS into 8 ohms, both channels driven from 20 Hz to 20 kHz with no more than 0.08% THD.

Surround Mode
 Front L/R Channels
 2 × 50 W (1 kHz, 0.08%, 8 ohms)
 Center Channel
 50 W (1 kHz, 0.15%, 8 ohms)
 Rear Channels (Rear channel only driven)
 15 W + 15 W (1 kHz, 0.3%, 8 ohms)

European models: Stereo mode
 2 × 60 watts at 6 ohms (DIN)

Surround mode
 Front L/R and Center Channels
 3 × 50 watts at 6 ohms (DIN)
 Rear Channels (Rear channel only driven)
 15 watts + 15 watts at 6 ohms (DIN)

Asian models: Stereo mode
 2 × 80 watts at 6 ohms, 1 kHz (EIAJ)

Surround mode
 Front L/R and Center Channels
 3 × 65 watts at 6 ohms, 1 kHz (EIAJ)
 Rear Channels (Rear Channel only driven)
 20 watts + 20 watts at 6 ohms, 1 kHz (EIAJ)

Total Harmonic Distortion: 0.08% at rated power (Front)

IM Distortion: 0.08% at rated power (Front)

Damping Factor: 60 at 8 ohms (Front)

Input Sensitivity and Impedance

Phono: 2.5 mV, 50 kohms

Line (CD, Tape, TV/AUX Video-1, 2):
 200 mV, 50 kohms

Video (Video-1,2): 1 Vp-p, 75 ohms

Output Level and Impedance: Rec Out (Tape): 200 mV, 2.2 kohms

Out (Video-2): 200 mV, 2.2 kohms

Pre Out (Subwoofer): 1 V, 2.2 kohms

Video (Video-2, Monitor):
 1 Vp-p, 75 ohms

Phono Overload: 120 mV RMS. at 1 kHz, 0.5% T.H.D.

Frequency Response: 20 Hz to 30 kHz, ±1 dB

RIAA Deviation: 20 Hz to 20 kHz, ±0.8 dB

Tone Control

Bass: ±10 dB at 100 Hz

Treble: ±10 dB at 10 kHz

Signal-to-Noise Ratio

Phono: 80 dB (IHF A, 5 mV input)

CD/Tape: 100 dB (IHF A)

Muting: -50 dB

VIDEO SECTION

Signal sensitivity and impedance: 1 Vp-p, 75 ohms (VDP/VCR input, output)

TUNER SECTION

FM

Tuning Range:

U.S.A. & Canadian models: 87.5 — 108.0 MHz (100 kHz steps)
 Other areas: 87.50 — 108.00 MHz (50 kHz steps)

Usable Sensitivity

Mono: 11.2 dBf, 1.0 μV (75 ohms IHF)
 Stereo: 17.2 dBf, 2.0 μV (75 ohms IHF)

50dB Quieting Sensitivity

Mono: 18.2 dBf, 2.2 μV (75 ohms)
 Stereo: 38.2 dBf, 22 μV (75 ohms)

Capture Ratio:

1.5 dB

Image Rejection Ratio

U.S.A. & Canadian models: 40 dB
 Other area models: 85 dB

IF Rejection Ratio:

90 dB

Signal-to-Noise Ratio

Mono: 73 dB (IHF)
 Stereo: 67 dB (IHF)

Alternate Channel Attenuation

Mono: 55 dB (IHF)

Selectivity: 50 dB (DIN, ±300 kHz, 40 kHz Devi.)

AM Suppression Ratio:

50 dB

Total Harmonic Distortion

Mono: 0.15%
 Stereo: 0.25%

Frequency Response:

30 Hz — 15 kHz, ±1.5 dB

Stereo Separation:

45 dB at 1 kHz
 30 dB at 100 Hz — 10 kHz

AM

Tuning Range

U.S.A. & Canadian models: 530—1,710 kHz (10 kHz steps)

European models: 522—1,611 kHz (9 kHz steps)

Worldwide models: 531—1,602 kHz (9 kHz steps),
 530—1,710 kHz (10 kHz steps)

Usable Sensitivity:

30 μV

Image Rejection Ratio:

40 dB

IF Rejection Ratio:

40 dB

Signal-to-Noise Ratio:

40 dB

Total Harmonic Distortion:

0.7%

GENERAL

Power Supply

U.S.A. & Canadian models: AC 120 V, 60 Hz

European & Australian models: AC 230 V, 50 Hz

Worldwide models: AC 230-220 V and 120 V switchable, 50/60 Hz

Power Consumption

U.S.A. & Canadian models: 2.7 A

Other area models: 220 W

Dimensions (W × H × D):

435 × 150 × 322 mm
 17-1/8" × 5-7/8" × 12-11/16"

Weight:

8.2 kg, 18.1 lbs.

REMOTE CONTROL RC-328S

Transmitter: Infrared

Signal range: Approx. 5 meters, 16 ft.

Power supply: Two "AA" batteries (1.5 V × 2)

Specifications and features are subject to change without notice.

SERVICE PROCEDURES

1. Replacing the fuses

 This symbol located near the fuse indicates that the fuse used is fast operating type. For continued protection against fire hazard, replace with same type fuse. For fuse rating refer to the marking adjacent to the symbol.

 Ce symbole indique que le fusible utilise est a rapide. Pour une protection permanente, n'utiliser que des fusibles de meme type. Ce dernier est indique la qu le present symbol est appose.

Circuit No.	Part No.	Description
F901	252164Y	5A-UL/T-237,Primary <D/W>
F902	252075	2.5A-SE-EAK,Primary <W,K,A>
F902,F903	252075Y	2.5A-SE-EAK, Primary <P,T>
NOTE:		<D>: 120Vmodel only <P>: 230V model only <W>: Worldwide model only <K>: Korean model only <A>: Australian model only <T>: Taiwanese model only

2. To Initialize the unit

This device employs a microprocessor to perform various functions and operations. If interference generated by an external power supply, radio wave, or other electrical source results in accident which causes the specified operations and functions to operate abnormally.

To perform a result, please follow the procedure below.

1. Press and hold down the VIDEO-1 button, then press the SPEAKER-A button.
2. After "clear" is displayed, the preset memory and each mode stored in then memory, such as surround, are initialized and will return to the factory settings.

3. Safety-check out

(Only U.S.A. model)

After correcting the original service problem, perform the following safety check before releasing the set to the customer. Connect the insulating-resistance tester between the plug of power supply cord and the screw on the back panel.

Specifications: 3.3 Mohm \pm 10% at 500V.

4. Change of voltage

Worldwide models are equipment with a voltage selector to conform with local power supplies. This switch is located on the back panel.

Be sure to set this switch to match the voltage of the power supply in your area before turning the power switch on.

This switch is set to 220V at the factory. Voltage is changed by

sliding the groove in the switch with the screwdriver to the right or left. Confirm that the switch has been moved all the way to the right or left before turning the power switch on.

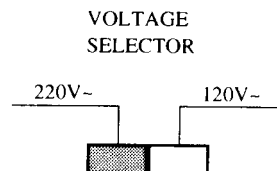

5. Memory preservation

This unit does not require memory preservation batteries.

A built-in memory power back-up system preserves contents of the memory during power failures and even when the unit is unplugged.

The unit must be plugged in and the power switch turned on and off once in order to charge the back-up system. Note that since this is not a permanent memory, the power switch must be turned on and off a few times each month the keep the back-up system operative.

The period of the time during which memory contents are preserved after power has last been turned off varies depending on climate and placement of the unit. On the average, memory contents are protected over a period of 3 to 4 weeks (a minimum of 2 weeks) after the last time power has been turned off. This period is shorted when the unit is exposed to very high humidity or used in an area with an extremely humid climate.

6. Setting the tuning step frequency

Worldwide models are equipped with a step band selector switch. This switch is located on the back panel. This switch is set to 9 kHz at the factory, but may have to be reset to 10 kHz depending on the area where the unit is used.

	AM band step
Europe:	9 kHz
U.S.A.:	10 kHz

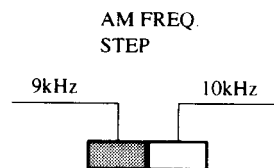

7. Changing the band step

With the exception of the worldwide models, a tuning step selector switch is not provided. When you change the band step, change the parts as shown below.

	To 10 kHz	To 9 kHz
R727	Remove	10 ohm
R724	10 k ohm	Remove

EXPLODED VIEW

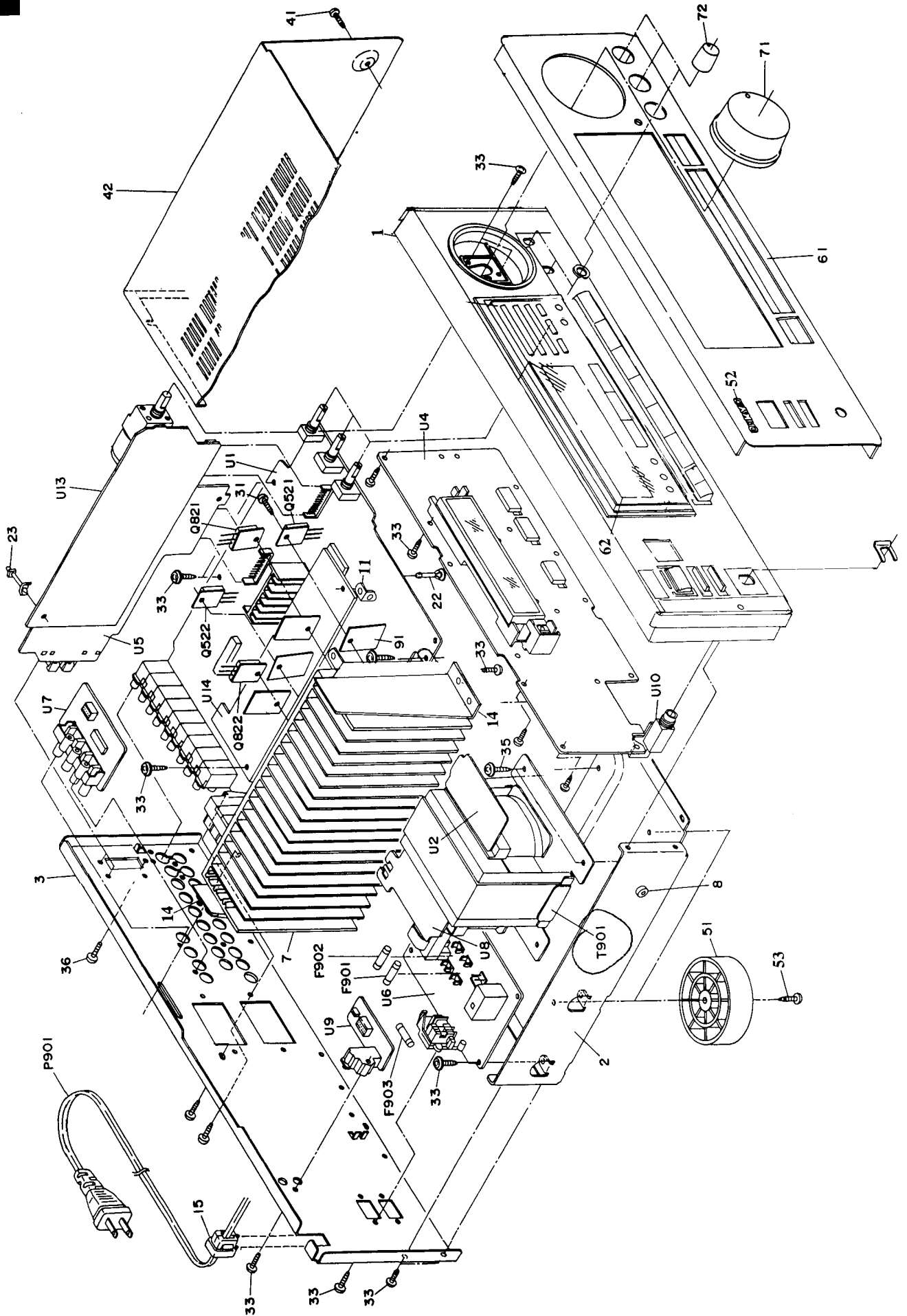

PARTS LIST

REF.NO.	PART NO.	DESCRIPTION	REF.NO.	PART NO.	DESCRIPTION	REF.NO.	PART NO.	DESCRIPTION
1	2710956AY	Front Bracket	P901	253192HITY or	AS-US-C-6#18(SFT-2), AC Cord <D>		1A722574-1EY	NAETC-5874-1E, Video circuit pc board ass'y <K>
2	271100321AY	Chassis		253193HITY or	AS-CEE, AC Cord <P,T>	U8	1A722574-1FY	NAETC-5874-1F, Video circuit pc board ass'y <A>
3	271122276Y	Rear Panel <D>		253195SMARY or	KS-AS, AC Cord <K>		1A722577-1AY	NAETC-5877-1A, Primary pc board ass'y <D>
	271122277Y	Rear Panel <P>		253213WSE or	AS-SAA, AC Cord <A>		1A722577-1BY	NAETC-5877-1B, Primary pc board ass'y <P>
	271122278Y	Rear Panel <T>		253211WSE	AS-CEE-2, AC Cord <W>		1A722577-1CY	NAETC-5877-1C, Primary pc board ass'y <W>
	271122279Y	Rear Panel <W>		253219THITY	NSCT-2P1357, AC Outlet <A>	U9	1A722577-1DY	NAETC-5877-1D, Primary pc board ass'y <T>
	271122280AY	Rear Panel <K>		253233KAW	NSCT-2P1056, AC Outlet <K>		1A722577-1EY	NAETC-5877-1E, Primary pc board ass'y <K>
	271122355Y	Rear Panel <A>	P904,P905	25051570Y	25CS198-O, Transistor		1A722577-1FY	NAETC-5877-1F, Primary pc board ass'y <A>
7	271600377Y	Radiator		25051266	2SA1941-O, Transistor		1A722575-1AY	NAETC-5875-1A, RI Terminal pc board ass'y <D>
11	27141530AY	Retainer		Q521,Q522	25CS198-O, Transistor		1A722575-1BY	NAETC-5875-1B, RI Terminal pc board ass'y <D>
14	27141672Y	Retainer (H)		Q523,Q524	25CS198-O, Transistor		1A722575-1CY	NAETC-5875-1C, RI Terminal pc board ass'y <D>
15	27300750	Cord Bushing, #2271		Q821	25CS197-O, Transistor		1A722575-1DY	NAETC-5875-1D, RI Terminal pc board ass'y <D>
21	27190991	Holder, HGPS-16F		Q822	25A1941-O, Transistor		1A722575-1FY	NAETC-5875-1F, RI Terminal pc board ass'y <K>
22	27190266Y	Holder, KGLS-12RF		Q823	25A1940-O, Transistor	U10	1A722578-1AY	NAETC-5878-1A, Headphone Terminal pc board ass'y <D>
23	27190896Y	Holder, KGLS-10S		Q824	NPT-1284D, Power Transformer <D>		1A722578-1BY	NAETC-5878-1B, Headphone Terminal pc board ass'y <P>
31	801433	3MS8W.SW+14B(BC), Self-tapping screw		T901	NPT-1284G, Power Transformer <P,A,T>		1A722578-1CY	NAETC-5878-1C, Headphone Terminal pc board ass'y <W>
33	838130088	3TTB+8B, Self-tapping screw			NAAR-5864-1A, Main circuit pc board ass'y <D>		1A722578-1DY	NAETC-5878-1D, Headphone Terminal pc board ass'y <T>
35	830440089	4TTC+8C(BC), Self-tapping screw	U1	2301222	NAAR-5864-1B, Main circuit pc board ass'y <D>		1A722578-1EY	NAETC-5878-1E, Headphone Terminal pc board ass'y <K>
36	838230088	3TTB+8B(N), Self-tapping screw		1A722564-1AY	NAETC-5866-1A, Power Supply pc board ass'y <D>		1A722578-1FY	NAETC-5878-1F, Headphone Terminal pc board ass'y <A>
41	838430088	3TTB+8B(BC), Self-tapping screw	U2	1A722566-1BY	NAETC-5866-1B, Power Supply pc board ass'y <P>		1A722568-1AY	NAAF-5868-1A, Surround circuit pc board ass'y <D>
42	28184663Y	Top Cover		1A722571-1AY	NADJS-5871-1A, Display circuit pc board ass'y <D>		1A722568-1BY	NAAF-5868-1B, Surround circuit pc board ass'y <P>
51	27175319Y	Leg	U4	1A722571-1BY	NADJS-5871-1B, Display circuit pc board ass'y <T>		1A722569-1AY	NAAF-5869-1A, Center and Rear Amplifier circuit pc board ass'y <D>
51a	28141332Y	Cushion, t=1.5		1A722571-1CY	NADJS-5871-1C, Display circuit pc board ass'y <W>	U13	1A722569-1BY	NAAF-5869-1B, Center and Rear Amplifier circuit pc board ass'y <P>
52	28135244	Badge		1A722571-1DY	NADJS-5871-1D, Display circuit pc board ass'y <T>			
53	831430088	3TTW+8B(BC), Self-tapping screw	U5	1A722572-1AY	NARF-5872-1A, Tuner circuit pc board ass'y <D>			
62	28191755A	Clear Plate		1A722572-1BY	NARF-5872-1B, Tuner circuit pc board ass'y <P>			
69	27211870Y	Front Panel <D>		1A722572-1CY	NARF-5872-1C, Tuner circuit pc board ass'y <W>			
	27211871Y	Front Panel <P>		1A722572-1DY	NARF-5872-1D, Tuner circuit pc board ass'y <T>			
	27211872AY	Front Panel <T,W,K,A>		1A722572-1EY	NARF-5872-1E, Tuner circuit pc board ass'y <K>			
71	28325456Y	Knob (VOL)		1A722573-1AY	NAPS-5873-1A, Power Supply circuit pc board ass'y <D>	U6	1A722569-1BY	NAAF-5869-1B, Center and Rear Amplifier circuit pc board ass'y <P>
72	28325454Y	Knob (TONE)		1A722573-1BY	NAPS-5873-1B, Power Supply circuit pc board ass'y <P>			
73	28325451Y	Knob (POW)		1A722573-1CY	NAPS-5873-1C, Power Supply circuit pc board ass'y <W>			
74	27267955Y	Guide (POW)		1A722573-1DY	NAPS-5873-1D, Power Supply circuit pc board ass'y <T>			
91	223024	* Isolation Sheet, AC238		1A722573-1EY	NAPS-5873-1E, Power Supply circuit pc board ass'y <K>			
D911	22380038 or 22380274	RBV602 or RS603M Diode	U6	1A722573-1FY	NAPS-5873-1F, Power Supply circuit pc board ass'y <A>			
P711	2047315012Y	NCF7-315012, Flexible Flat cable		1A722573-1AY	NAETC-5874-1A, Video circuit pc board ass'y <D>			
F901	252164Y	5A-UL, T-237, Fuse <D,W>	U7	1A722573-1BY	NAETC-5874-1B, Video circuit pc board ass'y <P>			
F902	252075Y	2.5A-SE-EAK, Fuse <K,A>		1A722573-1CY	NAETC-5874-1C, Video circuit pc board ass'y <W>			
	252075Y	2.5A-SE-EAK, Fuse <W>		1A722573-1DY	NAETC-5874-1D, Video circuit pc board ass'y <T>			
F902,F903	252075Y	2.5A-SE-EAK, Fuse <P,T>		1A722574-1AY	NAETC-5874-1A, Video circuit pc board ass'y <D>			
	252075Y	2.5A-SE-EAK, Fuse <P,T>		1A722574-1BY	NAETC-5874-1B, Video circuit pc board ass'y <P>			
				1A722574-1CY	NAETC-5874-1C, Video circuit pc board ass'y <W>			
				1A722574-1DY	NAETC-5874-1D, Video circuit pc board ass'y <T>			

NOTE: THE COMPONENTS IDENTIFIED BY MARK ARE CRITICAL FOR RISK OF FIRE AND ELECTRIC SHOCK. REPLACE ONLY WITH PART NUMBER SPECIFIED.

NOTE: <D>: 120V model only
 <P>: 230V model only
 <W>: Worldwide model only
 <T>: Taiwanese model only
 <K>: Korean model only
 <A>: Australian model only

BLOCK DIAGRAM

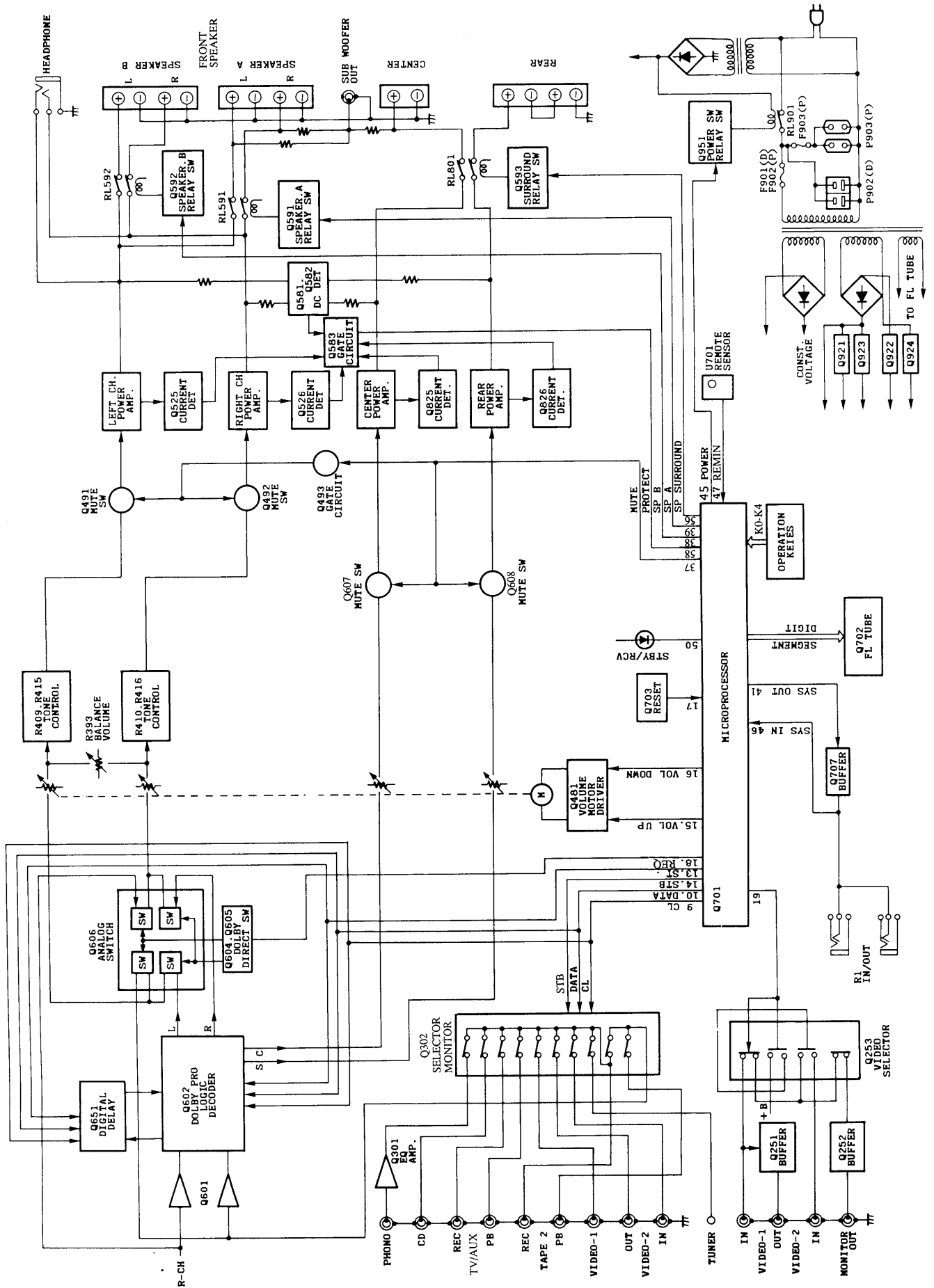

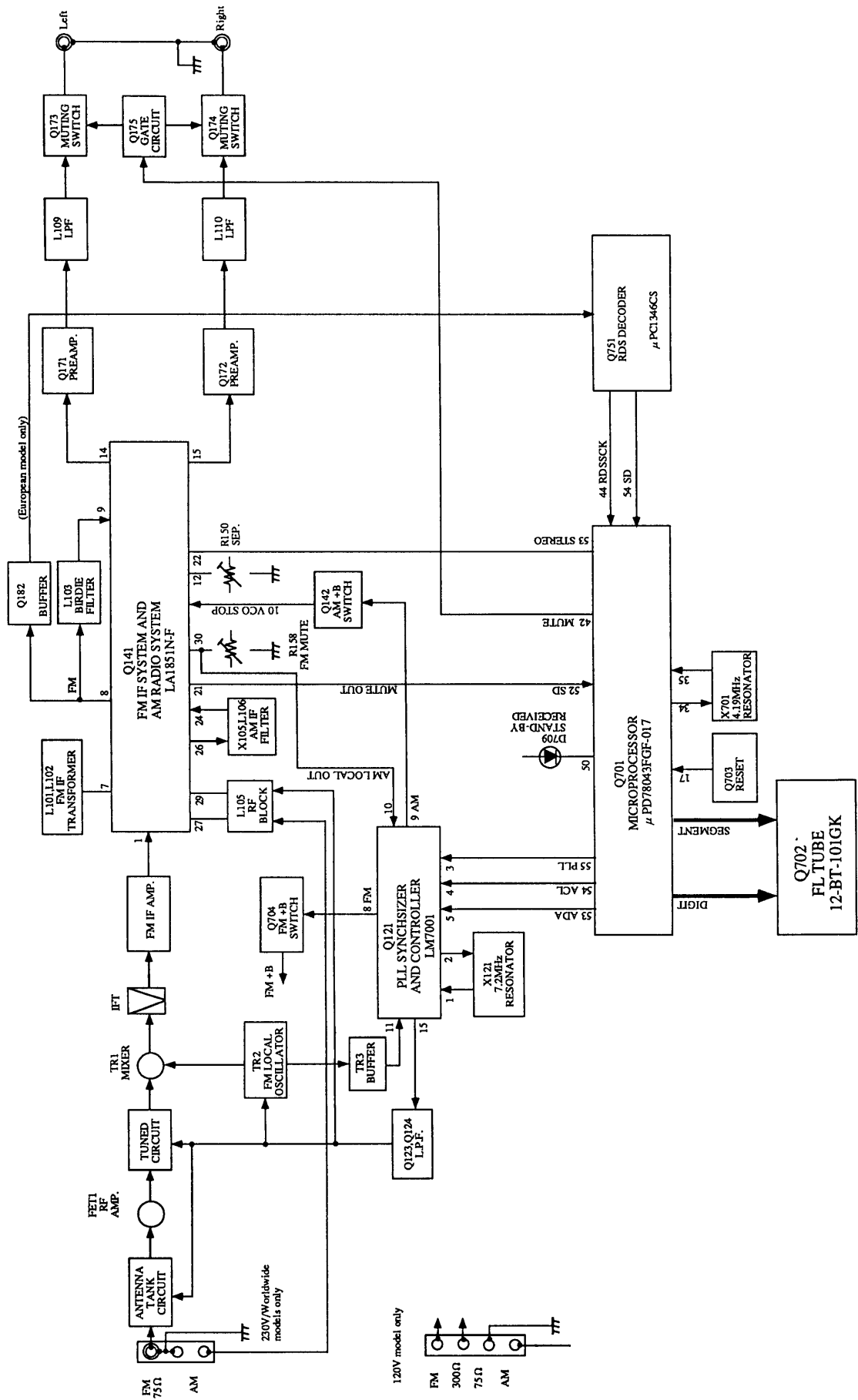

MICROPROCESSOR CONNECTION DIAGRAM

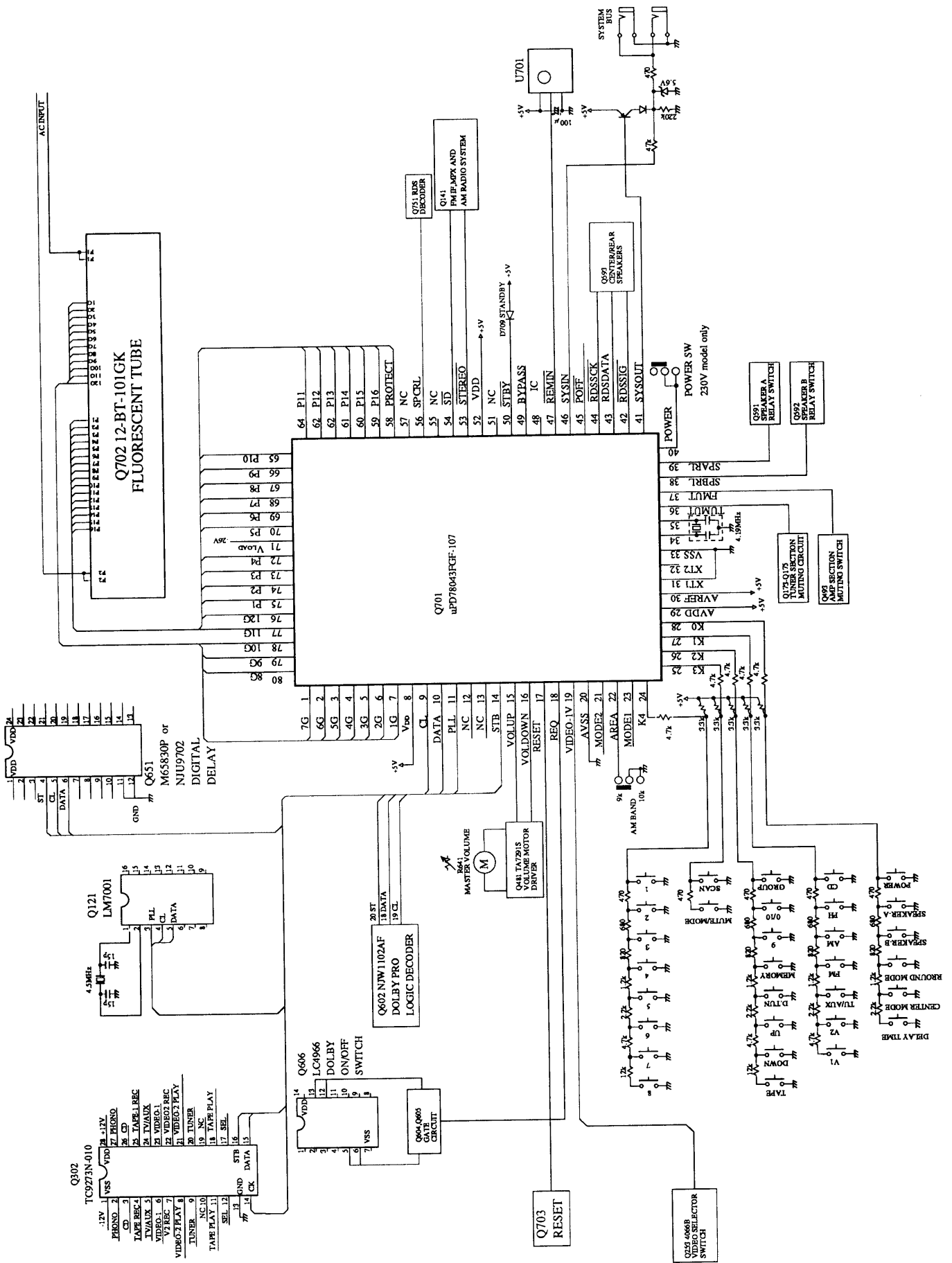

TERMINAL DESCRIPTION

Q701 μ PD78043FGF-017

Pin No.	Function	I/O	Description
1~7	7G~1G	O	Grid control output pin. On at the high level.
8	VDD		Power supply pin (+5V)
9	CL	O	Clock output pin. Connect to the terminals CK of function switch Q302, Dolby Pro Logic Decoder Q602, digital delay Q651 and PLL IC Q121.
10	DATA	O	Data output pin. Connect to the terminals DATA of function switch Q302, Dolby Pro Logic Decoder Q602, digital delay Q651 and PLL IC Q121.
11	PLL	O	Chip enable output pin for PLL IC Q121.
12	NC		
13	NC		
14	STB	O	Chip enable output pin. Connect to the terminal STB of function switch Q302.
15	VOLUP	O	Volume control output pin.
16	VOLDOWN	O	Volume control output pin. (Refer table 1.)
17	RESET	I	System reset input pin
18	REQ	O	Connect to the terminal REQ of Dolby pro logic.
19	VIDEO-1V	O	Video switch control output pin. On at the high level.
20	AVSS		Ground pin of A/D converter
21	MODE2	I	A or B setting input pin.
22	AREA	I	Initializing input of band region
23	MODE1	I	Initializing input of operation mode
24	K4	I	Operation key connection pin
25	K3	I	Operation key connection pin
26	K2	I	Operation key connection pin
27	K1	I	Operation key connection pin
28	K0	I	Operation key connection pin
29	AVDD		Analogue power supply of A/D converter
30	AVREF		Reference voltage input pin of A/D converter
31	XT1		Crystal connection pin for sub system clock resonator
32	XT2		Not used.
33	VSS		Ground pin
34	X1		Resonator connection terminal for main system clock
35	X2		Connect the ceramic resonator 4.19MHz.
36	TUMUT	O	Muting output pin for tuner section.
37	FRONTMUT	O	Muting output pin for front amp.
38	SPBRL	O	Relay control pin for speaker B
39	CENT SP	O	Relay control pin for center speaker.
40	POWER	O	Power source control output pin
41	SYSOUT	O	System code output pin
42	RDSSIG	I	Detector input pin of RDS broadcast. L:RDS broadcast
43	RDSDATA	I	Data input pin from RDS decoder uPD1346CS
44	RDSSCK	I	Clock input pin from RDS decoder IC uPC1346CS
45	POFF	I	Power stoppage detector input pin
46	SYSIN	I	System code input pin
47	REMIN	I	Remote control signal input pin
48	IC		Internal connection pin. Connect to the ground terminal.
49	BYPASS	I	Bypass select output pin
50	STBY/RECV	O	Standby and received indicator output pin
51			
52	VDD		Power supply pin (+5V)
53	STEREO	I	Detector input pin of FM stereo broadcast
54	SD	I	Detector input pin of broadcast more than muting level
55	NC		
56	SPCRL	O	Relay control pin for center and rear speakers.
57	NC		
58	PROTECT		Detector input pin of protection circuit.
59~70	P16 - P5	O	Segment output pins. On at the high level.
71	VLOAD	I	Pull-down resistor connection pin of controller and driver of FL.
72~75	P4 - P1	O	Segment output pins. On at the high level.
76~80	12G~8G	O	Grid control output pins. On at the high level.

Operation	#15	#16
VOLUME UP	H	L
VOLUME DOWN	L	H
STOP	H	H

Table 1

PACKING VIEW

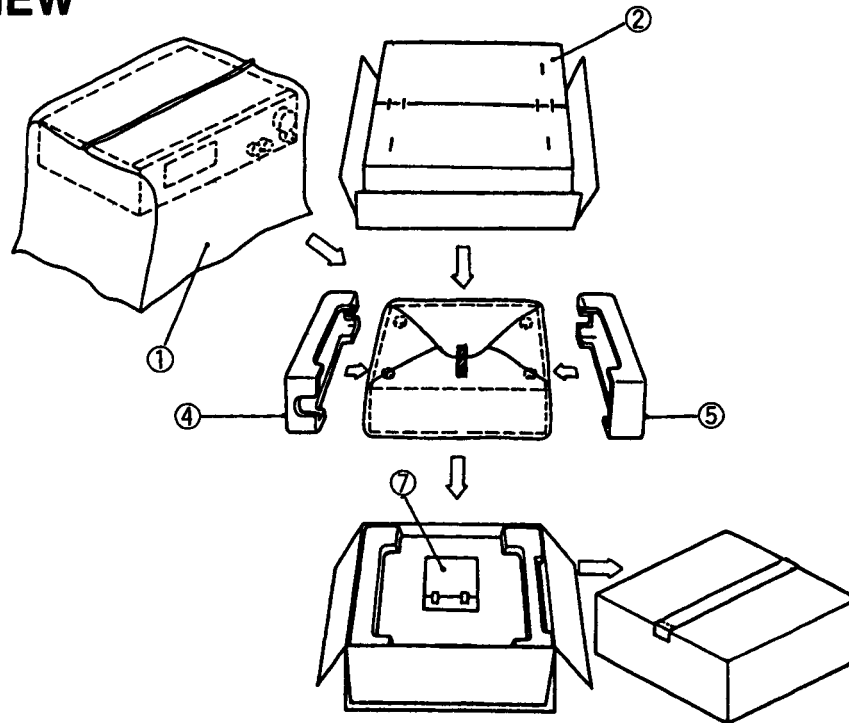

PACKING LIST

REF.NO.	PART NO.	DESCRIPTION
1	29100034-1AY	Styren Bag 850x650
2	29053093Y	Carton Box <D>
	29053094Y	Carton Box <W,T,K,A>
	29053095Y	Carton Box <P>
4,5	29091763Y	Pad (AS), L and R
	Accessory bag ass'y	
	232140	NMA-3057, AM Loot Antenna
	292111	FM Antenna <D>
	292112	FM Antenna <P>
	24140328Y	RC-328S, Remote Control transmitter
	3010194	UM-3, Batteries
	25055018	CV-1K-1, Conversion Plug <W>
	25065462	YAE21-0237, FM antenna Adapter <W,P,K,A>
	29361786Y	Label (MALAYSIA) <P,K>
	29362091Y	Label (EAN) AS <P,T,K>
	29362003-1	Label <D>
	29360708Y	Label (UL) <D>
	29362003-1Y	Label (UPC) AS <D>
	29342360Y	Instruction Manual, E
	29342361Y	Instruction Manual, U3FSI <P>
	29342362Y	Instruction Manual, U3GSwD <P>
	29342364Y	Instruction Manual, T <W,T>
	29355133AY	Instruction Sheet (DBP) <P>
	29355221	Instruction Sheet <K>
	29365019BY	Warranty Card <D>
	29358002KY	Service Station List <D>

ADJUSTMENT PROCEDURES

Preparation

1. Input

FM mono: 1 kHz, 75 kHz devi., 60 dB/ μ V
 FM stereo: 1 kHz, 75 kHz devi., 60 dB/ μ V
 Pilot signal :19 kHz,7.5 kHz devi.
 AM : 400Hz ,30% mod.

2. Outputs

Connect the non-inductive type resistors of 8 ohms to the speaker terminals A unless otherwise noted.

3. Standard Knob Positions

Master Volume Control	Maximum
Bass Control	Center
Treble Control	Center
Balance Control	Center
Input Selector.....	CD
Tape (Monitor).....	Off
Muting	Off
Speaker	A on, B off
Dolby Surround	Off
Center Mode.....	Wide Band
Delay Time.....	20 ms
Center Level	0 dB
Rear Level	0 dB

IDLING CURRENT ADJUSTMENT

1. Connect the DC voltmeter to the terminals P521, P522 and P821(VCT and IID) on the main circuit pc board.
2. Adjust the trim resistors R533, R534 and R837 so that the indicator of voltmeter becomes 2.0mV.
3. After 4 - 6 minutes of heat runing, readjust R533 , R534 and R837 to get 5.5 - 6.0mV.

NOTE: Set Volume knob to the minimum position.

- Set the unit to the test mode.
1. Press and hold down the CD button, then press the Power button.
 2. "TEST." is displayed on the display.
 3. While "TEST." is displayed, press the FM key.

FM ADJUSTMENT

Item	Step	Connection of instrument	FM SG output	Stereo modulation output	Tuning frequency	Output indicator	Adjustment point	Adjust for	Remarks
FM IFRF	1		99.0MHz		99.0MHz	DC voltmeter	L101	0±20mV	FM MUTE/MODE switch/ON/STEREO Repeat the steps 1 and 5 until no further adjustment is necessary.
	2	Fig.1	1kHz, 75kHz dev., 65dB(60dB)			AC voltmeter	IFT on the front end	Maximum	
	3					Distortion analyzer	L102	Minimum	
Stereo Distortion	1	Fig.2	99.0MHz Ext. mod. 65dB(60dB)	Channel L or R 1kHz	99.0MHz	Distortion analyzer	IFT on the front end	Minimum	Don't turn more than ±180°
	2	Fig.2	99.0MHz Ext. mod. 65dB(60dB)	Channel L 1kHz Channel R 1kHz	99.0MHz	Channel R AC voltmeter Channel L AC voltmeter	R150	Minimum	Maximum and same separation
Mixing Level	1	Fig.2	99.0MHz 2L2dB(L60B) 27W Mode(S> 23.2dB(18dB) <D mode>		99.0MHz	Oscilloscope or TUNED indicator	R158	Signal output or light on	
	2	Fig.3	99.0MHz Ext. mod. 40dB	RDS data or 57kHz 3% dev.	99.0MHz	Oscilloscope	R786	Maximum	European model only

AM ADJUSTMENT

1280 model

Step	AM SG output	Tuning Frequency	Output Indicator	Adjustment point	Adjust for
1		530kHz	Digital DC voltmeter	OSC coil on RF block L105	1.3±0.1V
2	600kHz 40Hz 30% mod. 60dB/m	600kHz	AC voltmeter	RF coil on RF block L105	Maximum
3	990kHz 400Hz 30% mod. 60dB/m	990kHz	AC voltmeter	L106	Maximum

Reference Specification
 FM tuned voltage: 87.9MHz ~ 107.9MHz
 Less than 10V
 AM tuned voltage: 530kHz ~ 1710kHz
 1.3±0.2V ~ Less than 9.0V

238U and worldwide models

Step	AM SG output	Tuning Frequency	Output Indicator	Adjustment point	Adjust for
1		522kHz 531kHz	Digital DC voltmeter	OSC coil on RF block L151	1.3±0.1V
2	603kHz 40Hz 30% mod. 60dB/m	603kHz	AC voltmeter	RF coil on RF block L105	Maximum
3	999kHz 400Hz 30% mod. 60dB/m	999kHz	AC voltmeter	L106	Maximum

Reference Specification
 FM tuned voltage: 87.5MHz ~ 108.0MHz
 Less than 10V
 AM tuned voltage: 522kHz ~ 1611kHz
 1.3±0.2V ~ Less than 9.0V
 (230V model)
 AM tuned voltage: 531kHz ~ 1602kHz
 Less than 9.0V
 (Worldwide model)

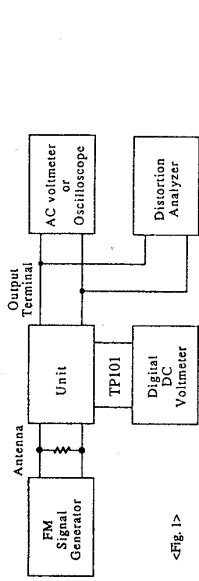
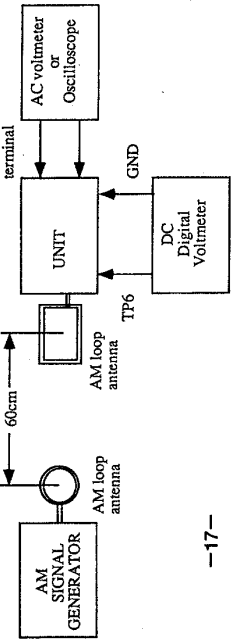

<Fig. 1>

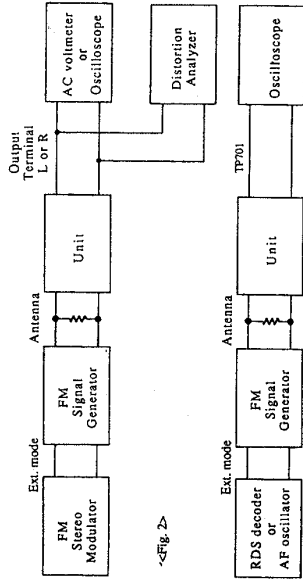

<Fig. 2>

<Fig. 3>

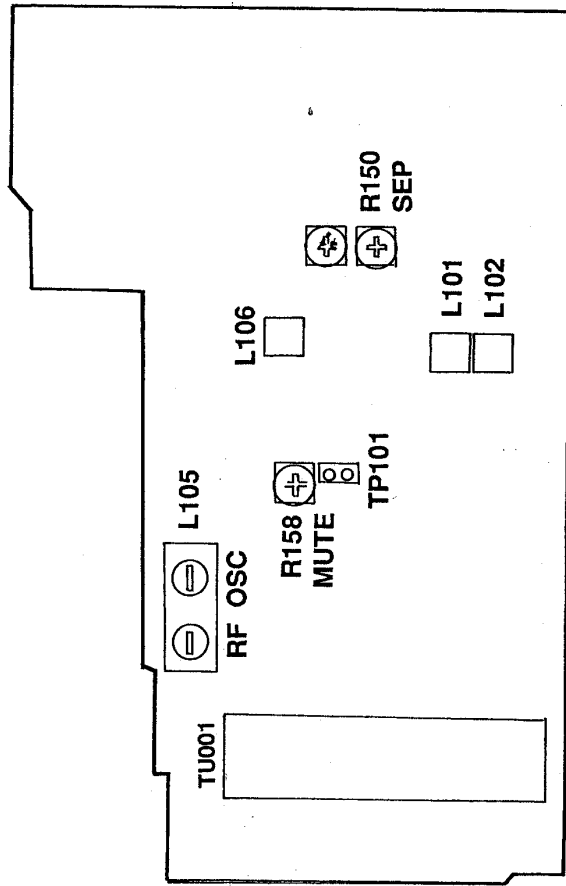

PRINTED CIRCUIT BOARD-PARTS LIST

U1 MAIN CIRCUIT PC BOARD (NAAR-5864-1A/1B)

CIRCUIT NO.	PART NO.	DESCRIPTION
	ICs	
Q301	222502	NJM4558D-X
Q302	22240881	TC9273N-010
Q401,Q402	22240250	NJM2068L-D
Q481	22240239	TA7291S
Q921	222780125NEC	MPC78M12AHF
Q922	222790125	79M12HF
Q923	222780565JRC	NJM78M56FA
	Transistors	
Q491,Q492	2213631	RN1241-A
Q493	2213510 or 2214350	DTA114ES or RN2202
Q501-Q504	2211733 or 2211732	* 2SC1845-E or * 2SC1845-F
Q505,Q506	2211353	2SA949-O
Q507,Q508	2211733 or 2211732	2SC1845-E or 2SC1845-F
Q509,Q510	2213284	2SC1740S-R
Q511,Q512	2211353	2SA949-O
Q513,Q514	2211633	2SC2229-O
Q515,Q516	2213284	2SC1740S-R
Q517,Q518	2203010	* 2SC5171
Q519,Q520	2203000	* 2SA1930
Q525,Q526	2211733 or 2211732	2SC1845-E or 2SC1845-F
Q527,Q528	2211353	2SA949-O
Q529,Q530	2211633	2SC2229-O
Q581,Q582	2211733 or 2211732	2SC1845-E or 2SC1845-F
Q583	2211792	2SA992-F
Q591-Q593	2213640	DTC123JS
Q924	2211455	2SA1015-GR
	Diodes	
D501,D502	22380260 or 22380032	RL1N4003 or 1SR139-100, GP104003E
D591,D592	223163	1SS133
D915-D921	22380260 or 22380032	△ RL1N4003 or △ 1SR139-100, GP104003E
D922	224472704	MTZJ27D, Zener
D923,D924	223163	1SS133
	Coils	
L501,L502	231176S	S-1.3C
	Capacitors	
C303,C304	354741009	10 μ F, 16V, Elect.
C307,C308	354721019	100 μ F, 6.3V, Elect.
C309,C310	374726224	6200pF \pm 5%, 50V, Plastic
C311,C312	374721824	1800pF \pm 5%, 50V, Plastic
C313-C316	354741009	10 μ F, 16V, Elect.
C391,C392	374721015	100pF \pm 10%, 50V, Plastic
C401,C402,C407	354741009	10 μ F, 16V, Elect.
C411,C412	354741009	10 μ F, 16V, Elect.
C421,C422	374721534	0.015 μ F \pm 5%, 50V, Plastic
C408	354741009	10 μ F, 16V, Elect.
C433,C434	374721534	0.015 μ F \pm 5%, 50V, Plastic
C435,C436	374721015	100pF \pm 10%, 50V, Plastic
C441	354721019	100 μ F, 6.3V, Elect.
C442	354780479	4.7 μ F, 50V, Elect.
C501,C502	354781009	10 μ F, 50V, Elect.
C503,C504	374721015	100pF \pm 10%, 50V, Plastic
C507,C508	354724719	470 μ F, 6.3V, Elect.

CIRCUIT NO.	PART NO.	DESCRIPTION
C513,C514	354722219	220 μ F, 6.3V, Elect.
C515,C516	354784719	470 μ F, 50V, Elect.
C521,C522	354784709	47 μ F, 50V, Elect.
C529,C530	374721044	0.1 μ F \pm 5%, 50V, Plastic
C581	354721019	100 μ F, 6.3V, Elect.
C911	374731034	0.01 μ F \pm 5%, 100V, Plastic
C915,C916	3504207	6800 μ F, 50V, Elect.
C918	354761029	1000 μ F, 35V, Elect.
C919	354763319	330 μ F, 35V, Elect.
C922-C925	354781009	10 μ F, 50V, Elect.
C926	354761019	100 μ F, 35V, Elect.
C928	354781019	100 μ F, 50V, Elect.
C932	354781009	10 μ F, 50V, Elect.
C983	374721034	0.01 μ F \pm 5%, 50V, Plastic
	Resistors	
R393	5104288	N11RCL, 250KWT20Z, Variable
R409,R415	5104356	N14RLC, 100KWT20Z, Variable
R511,R512	443525604	△ 56ohm \pm 5%, 1/2W, Metal oxide
R529-R532	443526804	△ 68ohm \pm 5%, 1/2W, Metal oxide
R533,R534	5210259	N06HR, 2KBC, Trim
R539,R540	443526804	△ 68ohm \pm 5%, 1/2W, Metal oxide
R541,R542	443525604	△ 56ohm \pm 5%, 1/2W, Metal oxide
R545,R546	4000132	RGCS5, 0.22OHMK, Metal Plate
R551,R552	453630824	8.2ohm \pm 5%, 1W, Metal
R563,R564	453530224	2.2ohm \pm 5%, 1/2W, Metal
R565,R566	443623914	390ohm \pm 5%, 1W, Metal oxide
R581,R582	443523314	△ 330ohm \pm 5%, 1/2W, Metal oxide
R583-R586	453530224	△ 2.2ohm \pm 5%, 1/2W, Metal
R933	443524704	47ohm \pm 5%, 1/2W, Metal oxide
	Relays	
RL591,RL592	25065517 or 25065485	NRL-2P5A-DC24-098 or NRL-2P2A-DC24-086
	Plugs	
P211a	25055709	NPLG-13P665
P611a	25055678	NPLG-8P634
P612a	25055704	NPLG-8P660
P613a	25055708	NPLG-12P664
	Pin Jack	
P301	25045460 or 25045303	NPJ-4PDBL281 or NPJ-4PDBL162
P302,P303	25045458 or 25045300	NPJ-6PDBL279 or NPJ-6PDBL159
P371	25045459 or 25045302	NPJ-1PDBL280 or NPJ-1PDBL161
	Terminals	
P501	25060224 or 25060158	NTM-8PDML146 or NTM-8PDML084
P521,P522	25060062	2P-5
	Radiator	
	27160209	RAD-67

U2 POWER SUPPLY PC BOARD (NAETC-5866-1A/1B)

CIRCUIT NO.	PART NO.	DESCRIPTION
	Resistors	
R921,R922	453530104	△ 1ohm \pm 5%, 1/2W, Metal

U4 DISPLAY CIRCUIT PC BOARD (NADIS-5871-1A/1F)

CIRCUIT NO.	PART NO.	DESCRIPTION
	IC	
Q701	22241055 or	MPD78043FGF-017 or

CIRCUIT NO.	PART NO.	DESCRIPTION	U5 TUNER CIRCUIT PC BOARD (NARF-5872-1A/1F)		
			CIRCUIT NO.	PART NO.	DESCRIPTION
Q751	22241056 22240679 Transistors	MPD78P044GF-343 MPC1346CS <P>			
Q703	221282	DTC144ES	Q121	22240090	LM7001
Q705,Q706	2213284	2SC1740S-R	Q141	22240983	LA1851N-F
Q707	2213510 FL Tube	DTA114ES	Q253	222840661	4066B
Q702	212156 Diodes	12-BT-101GK	Q101	2210746	2SC945A-P <P>
D701,D702	223163 or 223205	1SS133 or 1SS270A	Q102	2211723	2SC1923-O
D703	224470913	MTZJ9.1C, Zener	Q122	2213510	DTA114ES
D704,D705	223163 or 223205	1SS133 or 1SS270A	Q123	2212445	2SK365-GR
D706,D707	224470562	MTZJ5.6B, Zener	Q124	2213284	2SC1740S-R
D708	223163 or 223205	1SS133 or 1SS270A	Q142	2213510	DTA114ES
D709	225290	SEL4110R, LED	Q143	221282	DTC144ES
D710-D712	223163 or 223205	1SS133 or 1SS270A	Q144	2213640	DTC123JS
D751	223163 or 223205 Coils	1SS133 or <P> 1SS270A	Q171,Q172	2213284	2SC1740S-R
L701-L703	233454K220 Resonators	NCH-1452, 220K	Q173,Q174	2212794	2SD1468-R
X701	3010163	CST-4.19MGW, Ceramic	Q175	2213510	DTA114ES
X751	3010203 Capacitors	AF6146CG <P>	Q182	2213284	2SC1740S-R <P,W,K>
C701	3000076 or 3000078	0.01F,5.5V,Super	D165	224470512	MTZJ5.1B, Zener
C702	375524744	0.47 μ F \pm 5%, 50V, Plastic	L101,L102		Coils and Transformers
C703	354721019	100 μ F,6.3V,Elect.	L103	233457	NFIF-4081
C704-C707	353780109	1 μ F(S),50V,Elect.	L104	233471	NMC-6084 <P>
C709,C711	354721019	100 μ F,6.3V,Elect.	L105	233454K220	NCH-1452, 220K
C751	354721019	100 μ F,6.3V,Elect. <P>	L106	232174	NMRF-5077, RF Block
C754	374724724	4700pF \pm 5%,50V,Plastic <P>	L107	232139	NMIF-4062, IF Trans
C755,C756	374723324	3300pF \pm 5%,50V,Plastic <P>	L108	233484	NMC-4085 <P>
C757	354780229	2.2 μ F,50V,Elect. <P>	L109,L110	233484	NMC-4085 <P>
C758	374724734	0.047 μ F \pm 5%,50V,Plastic <P>		231092	NCH-2140
C759	374722234	0.022 μ F \pm 5%,50V,Plastic <P>			Ceramic Filters
C760	374724724	4700pF \pm 5%,50V,Plastic <P>	X101	3010071	SFE10.7MA5, (RED)
R708	49163103412 Resistors	RM1/10IJ, 10K*12, Net	X102	3010130	SFE10.7MZ2A <P>
R786	5210265 Switches	N06HR, 50KBC, Trim <P>	X103	3010071	SFE10.7MA5, (RED)
S701-S713	25035652	NPS-111-S604	X104	3010268	CSB456F23
S715-S724	25035652	NPS-111-S604	X105	3010123	SFZ-45OJL
S731-S738	25035652	NPS-111-S604	X121	3010141 or 3010158	XTL-7.2M, Crystal
S739	25035653 Socket	NPS-122-L605, P SW <P>	C001	354741019	100 μ F,16V, Elect.
P711b	25051875 or 25051335 Plug	NSCT-31P1662 or NSCT-31P1124, NSCT-31P727	C127	354721019	100 μ F,6.3V, Elect.
TP701	25055038 Remote Sensor	NPLG-2P29 <P>	C130	354780229	2.2 μ F, 50V,Elect.
U701	24130011 Holder	PIC-12043TE2	C131	374722234	0.022 μ F, \pm 10%, 50V,Plastic
	27190989	FL Display	C132	354783399	0.33 μ F,50V, Elect.
			C133,C142	354741019	100 μ F,16V, ELECT C
			C145	354741009	10 μ F,16V, Elect.
			C146	374723324	3300pF, \pm 5%,50V,Plastic
			C147	374721034	0.01 μ F \pm 5%, 50V,Plastic <P>
			C147	374721534	0.015 μ F \pm 5%,50V,Plastic <D,T>
			C149	354780479	4.7 μ F,50V, Elect.
			C151,C152	354780109	1 μ F,50V, Elect.
			C153	354783399	0.33 μ F,50V, Elect.
			C154	354741009	10 μ F, 16V,Elect.
			C155	374721034	0.01 μ F \pm 5%,50V,Plastic <D>
			C155	374724724	4700pF \pm 5%,50V,Plastic <P,K,A>
			C155	374725624	5600pF \pm 5%,50V,Plastic <W,T>
			C156	374721034	0.01 μ F \pm 5%,50V,Plastic <D>
			C156	374724724	4700pF \pm 5%,50V,Plastic <P,K,A>
			C156	374725624	5600pF \pm 5%,50V,Plastic <W,T>
			C159	354780229	2.2 μ F,50V, Elect.
			C160	354784799	0.47 μ F,50V, Elect.

CIRCUIT NO.	PART NO.	DESCRIPTION
C162,C166	353741009	10 μ F,16V, Elect.
C171,C172	354741009	10 μ F,16V, Elect.
C173,C174	374721024	1000pF \pm 5%,50V,Plastic
C177	354780229	2.2 μ F,50V, Elect.
C178	354741009	10 μ F,16V, Elect.
	Resistors	
R150	5210261	N06HR, 5KBC, Trim
R158	5210264	N06HR, 30KBC, Trim
	Socket	
P211b	25051238	NSCT-13P1028
	Plug	
TP101	25055038	NPLG-2P29
	Terminal	
P101	25060239 or 25060195	NTM-4PDML161 or <D> NTM-4PDML117
P101	25060222 or 25060117	NTM-2PDML144 or <P> NTM-2PDML051
	Front End	
TU001	240098	ENV172D1G1 <D>
	240102	FE417-G02 <P/W>
	Shield Plate	
	27150394	

U6 POWER SUPPLY CIRCUIT PC BOARD (NAPS-5873-1A/1F)

CIRCUIT NO.	PART NO.	DESCRIPTION
	Transistor	
Q951	2213284	2SC1740S-R
	Diodes	
D951-D954	22380032	Δ 1SR139-100
D955	223163 or 223205	1SS133 or 1SS270A
	Transformers	
T902	2300670A	Δ NPT-1111D <D>
	2300671A	Δ NPT-1111P <P,T,A>
	2300672A	Δ NPT-1111DG <W,K>
	Capacitors	
C901	3500191	Δ DE7150F103M, IS C
C952	354742219	220 μ F,16V,Elect.
	Resistors	
R901	431533355	Δ 3.3M ohm, \pm 10%,1/2W, Solid
R951	453530824	8.2 ohm, \pm 5%,1/2W, Metal
	Switch	
S901	25065437	Δ NSS-22157P, Slide <W>
	Plug	
P901a	25055675	NPLG-2P631
	Rela	
RL901	25065515 or 25065508	Δ NRL-1P5A-DC12-096 or <D> NRL-1P10A-DC12-093
	Fuse Holder	
F901a,F902a	25050065	YSH403T <W>
F903a	25050065	YSH403T <P,T>
	AC Outlet	
P902	25051126	NSCT-4P913 <D>
P903	25051125	NSCT-4P912 <P,W,T>

U7 VIDEO CIRCUIT PC BOARD (NAETC-5874-1A/1F)

CIRCUIT NO.	PART NO.	DESCRIPTION
	Transistors	
Q251	2213284	2SC1740S-R
Q252	2213284	2SC1740S-R

CIRCUIT NO.	PART NO.	DESCRIPTION
	Diodes	
D251	223163 or 223205	1SS133 or 1SS270A
	Capacitors	
C251,C252	354721019	100 μ F,6.3V, Elect.
C255,C256	354724719	470 μ F,6.3V,Elect.
C257	354721019	100 μ F,6.3V,Elect.
C259	354741019	100 μ F,16V,Elect.
	Jack	
P251	25045462 or 25045339	NPJ-4PDYE283 or NPJ-4PDYE190

U9 RI TERMINAL PC BOARD (NAETC-5875-1A/1F)

CIRCUIT NO.	PART NO.	DESCRIPTION
	Switch	
S961	25065286	NSS-22112, Slide <W>
	Jacks	
P961	25045481	NPJ-2PDBL299 <W>
P962	25065425	M3 Terminal

U10 HEADPHONE TERMINAL PC BOARD (NAETC-5878-1A/1F)

CIRCUIT NO.	PART NO.	DESCRIPTION
	Jacks	
P503	25045255	YKB21-5009

U13 SURROUND CIRCUIT PC BOARD (NAAF-5868-1A/1B)

CIRCUIT NO.	PART NO.	DESCRIPTION
	ICs	
Q601	22240247 or 22240293	BA15218N or NJM4558L-D
Q602	22241053	NJW1102AF
Q604	2212600	DTA124ES
Q605	2213160	DTC124ES
Q606	22240025	LC4966
Q611	22240247 or 22240293	BA15218N or NJM4558L-D
Q651	22240995 or 22240686	NJU9702 or M65830P
	Transistor	
Q607,Q608	2213631	RN1241-A
	Diodes	
D601,D651	224470562	MTZJ5.6B, Zener
D652,D653	223163	1SS133
	Ceramic Lock	
X651	3010217	CST2.04MG040
	Capacitors	
C601,C602	354780229	2.2 μ F,50V,Elect.
C605,C606	354781009	10 μ F,50V,Elect.
C607	354744709	47 μ F,16V,Elect.
C608	354741019	100 μ F,16V,Elect.
C609	354762209	22 μ F,35V,Elect.
C610	392842207	22 μ F,16V,Elect.
C611-C614	374721044	0.01 μ F \pm 5%,50V,Plastic
C615,C616	374726814	680pF \pm 5%,50V,Plastic
C617,C618	374722234	0.022 μ F \pm 5%,50V,Plastic
C619-C622	354781099	0.1 μ F,50V,Elect.
C621,C622	354781099	0.1 μ F,50V,Elect.
C623,C624	374724734	0.047 μ F \pm 5%,50V,Plastic
C625-C628	354782299	0.22 μ F,50V,Elect.

CIRCUIT NO.	PART NO.	DESCRIPTION	CIRCUIT NO.	PART NO.	DESCRIPTION
C629,C630	354780479	4.7 μ F,50V,Elect.	C808	354744709	47 μ F,16V,Elect.
C631	354786899	0.68 μ F,50V,Elect.	C827,C828	374724734	0.047 μ F \pm 5%,50V,Plastic
C632	374724734	0.047 μ F \pm 5%,50V,Plastic	C831	354781009	10 μ F,50V,Elect.
C633	374725624	5600pF \pm 5%,50V,Plastic	C867,C868	354780109	1 μ F,50V,Elect.
C634	374725614	560pF \pm 5%,50V,Plastic	C869,C870	354721019	100 μ F,6.3V,Elect.
C635	374721024	1000pF \pm 5%,50V,Plastic	C881,C882	354780109	1 μ F,50V,Elect.
C636	354780479	4.7 μ F,50V,Elect.	C883,C884	354781019	100 μ F,50V,Elect.
C637	354722219	220 μ F,6.3V,Elect.			Resistors
C638	354781099	0.1 μ F,50V,Elect.	R825,826	443526804	68ohm \pm 5%,1/2W, Metal Oxid
C639-C643	354781009	10 μ F,50V,Elect.	R833-R836	443526804	68ohm \pm 5%,1/2W, Metal Oxid
C644	354781099	0.1 μ F,50V,Elect.	R837	5215043	N08HR, 2KBC, Trim
C645	374724724	4700pF \pm 5%,50V,Plastic	R843,R844	443521014	100ohm \pm 5%,1/2W, Metal Oxid
C651	374722224	2200pF \pm 5%,50V,Plastic	R845,R846	4000132	RGC55, 0.22 OHMK, Metal Plate
C652,C653	374725614	560pF \pm 5%,50V,Plastic	R849,R850	443521004	10ohm \pm 5%,1/2W, Metal Oxid
C654,C655	374721044	0.1 μ F \pm 5%,50V,Plastic	R851,R852	453630824	8.2ohm \pm 5%,1W, Metal
C656	374725624	5600pF \pm 5%,50V,Plastic	R859,R863	453530224	2.2ohm \pm 5%,1/2W, Metal
C657	354744709	47 μ F,16V,Elect.	R867-R870	453530224	2.2ohm \pm 5%,1/2W, Metal
C658,C659	354781099	0.1 μ F,50V,Elect.	R873,R874	443525604	56ohm \pm 5%,1/2W, Metal Oxid
C660	354781009	10 μ F,50V,Elect.			Relay
C661,C662	354721019	100 μ F,6.3V,Elect.	RL801	25065517 or 25065485	NRL-2P5A-DC24-098 or NRL-2P2A-DC24-086
C681-C684	354781009	10 μ F,50V,Elect.			Terminal
	Resistor		P801	25060220 or 25060191	NTM-6PDML142 or NTM-6PDML113
R641	5104347	N16RQL, 100KBT25F, Variable	P821	25060062	2P-5
	Socket				
P611b	25051127	NSCT-8P914			
P612b	25051233	NSCT-8P1023			
P613b	25051237	NSCT-12P1027			
	Plug				
P622a	25055405	NPLG-3P387			

U14 CENTER AND REAR AMPLIFIER CIRCUIT PC BOARD (NAAF-5869-1A/1B)

CIRCUIT NO.	PART NO.	DESCRIPTION
	Transistors	
Q803,Q804	2211633 or 2211634	2SC2229-O or 2SC2229-Y
Q805,Q806	2211353 or 2211354	2SA949-O or 2SA949-Y
Q807-Q810	2213284	2SC1740S-R
Q811,Q812	2211353 or 2211354	2SA949-O or 2SA949-Y
Q813,Q814	2211633 or 2211634	2SC2229-O or 2SC2229-Y
Q815,Q816	2213284	2SC1740S-R
Q817,Q818	2203010	2SC5171
Q819,Q820	2203000	2SA1930
Q825,Q826	2211733 or 2211732	2SC1845-E or 2SC1845-F
Q831,Q832	2211353 or 2211354	2SA949-O or 2SA949-Y
Q833,Q834	2211733 or 2211732	2SC1845-E or 2SC1845-F
Q835,Q836	2211733 or 2211732	2SC1845-E or 2SC1845-F
	Diode	
D811	223163	1SS133
	Coils	
L801,L802	231176	S-1.3C
	Capacitors	
C801,C802	354781009	10 μ F,50V,Elect.
C807	354742219	220 μ F,16V,Elect.

NOTE: <D>: 120V model only
 <P>: 230V model only
 <W>: Worldwide model only
 <T> : Taiwanese model only
 <K>: Korean model only
 <A>: Australian model only

SCHEMATIC DIAGRAM PART-1

A B C D E F G

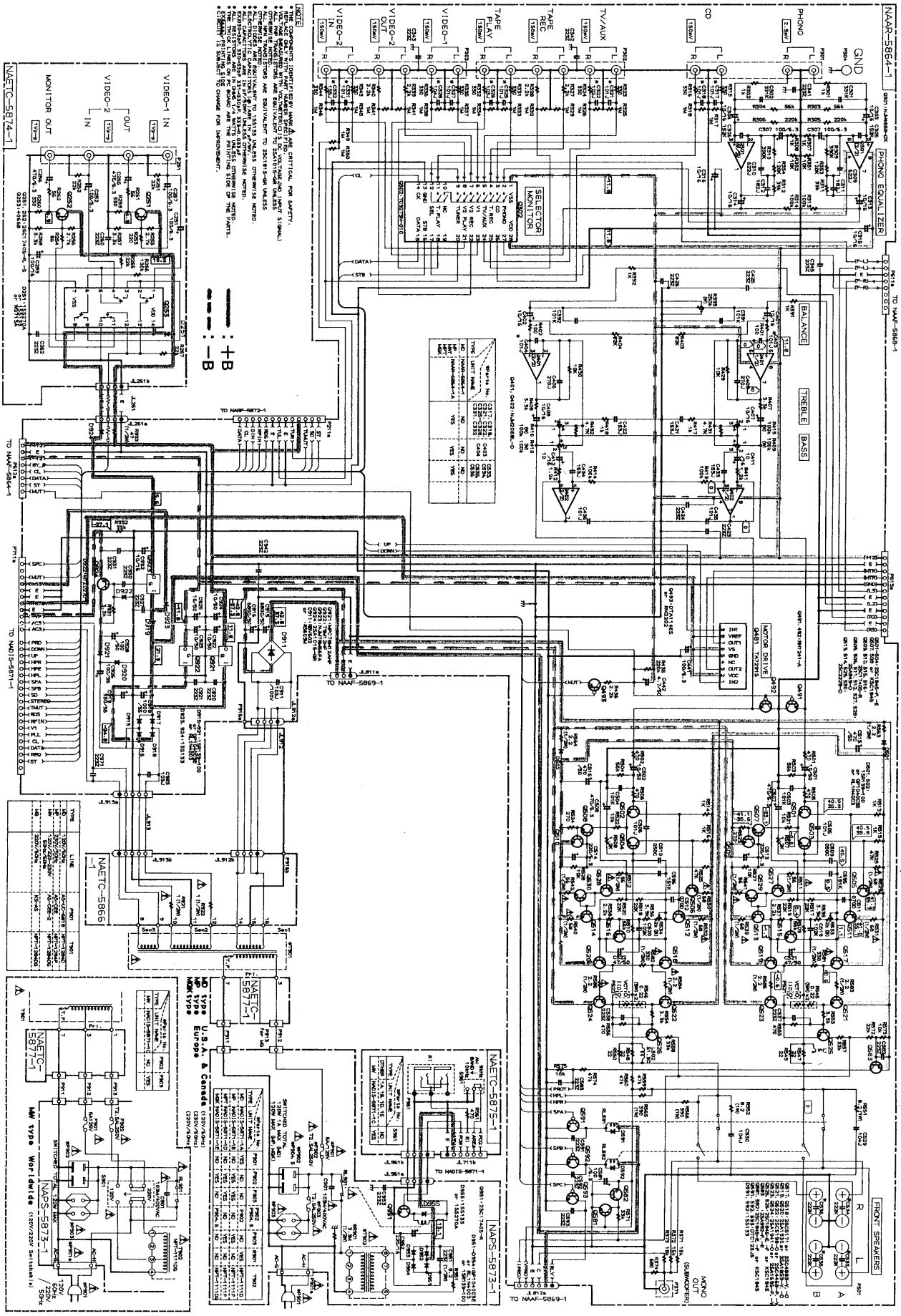

SCHEMATIC DIAGRAM PART-2

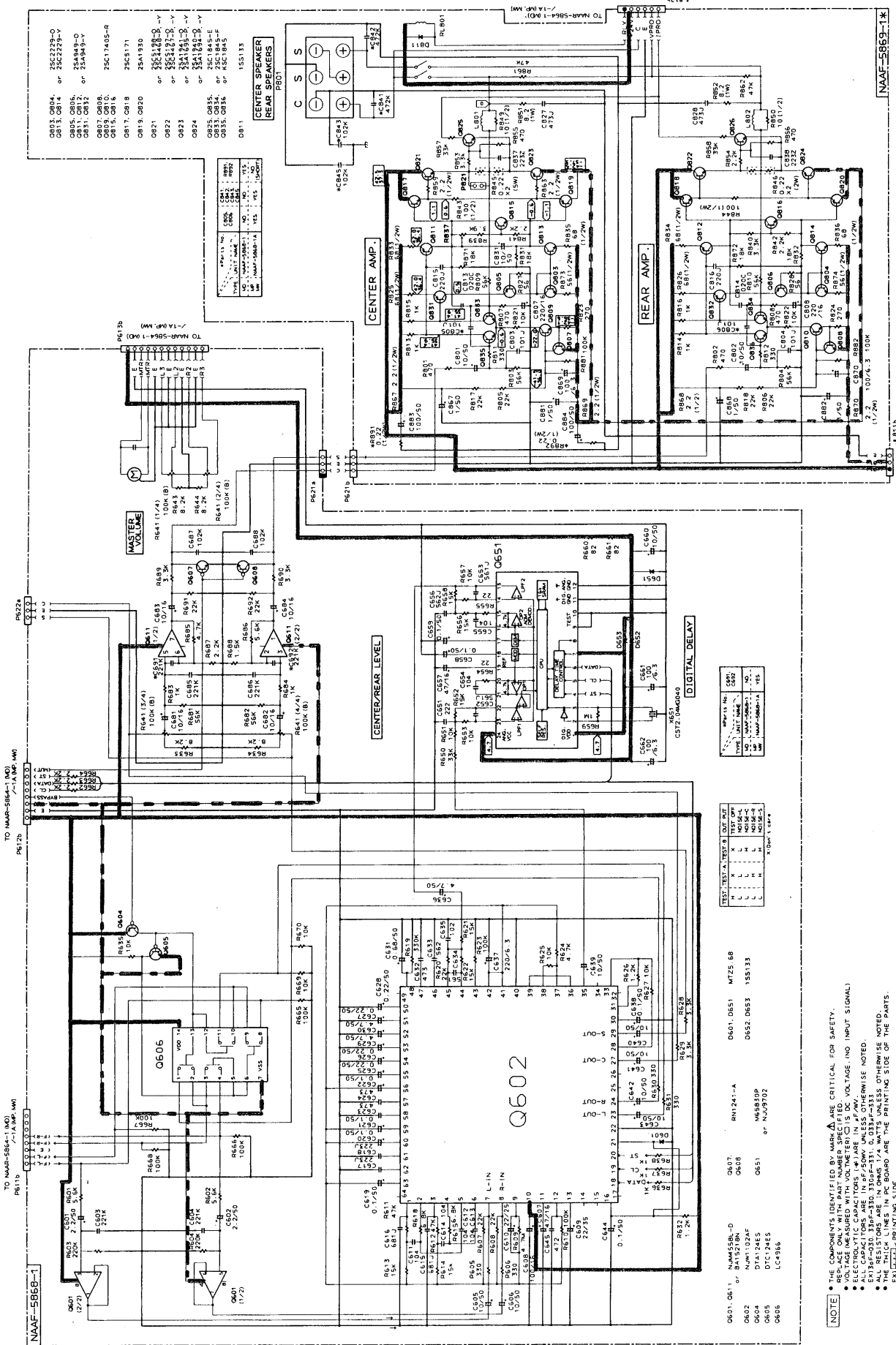

NOTE

- THE COMPONENTS IDENTIFIED BY MARK Δ ARE CRITICAL FOR SAFETY. REPLACE WITH PART NUMBER SPECIFIED.
- ALL CAPACITORS ARE IN P.F./50V UNLESS OTHERWISE NOTED.
- ALL RESISTORS ARE IN Ω/K/Ω/M/Ω UNLESS OTHERWISE NOTED.
- THE THICK LINES IN PCB BOARD ARE THE PRINTING SIDE OF THE PARTS.
- CIRCUIT IS SUBJECT TO CHANGE FOR IMPROVEMENT.

A B C D E F G

SCHEMATIC DIAGRAM PART-3

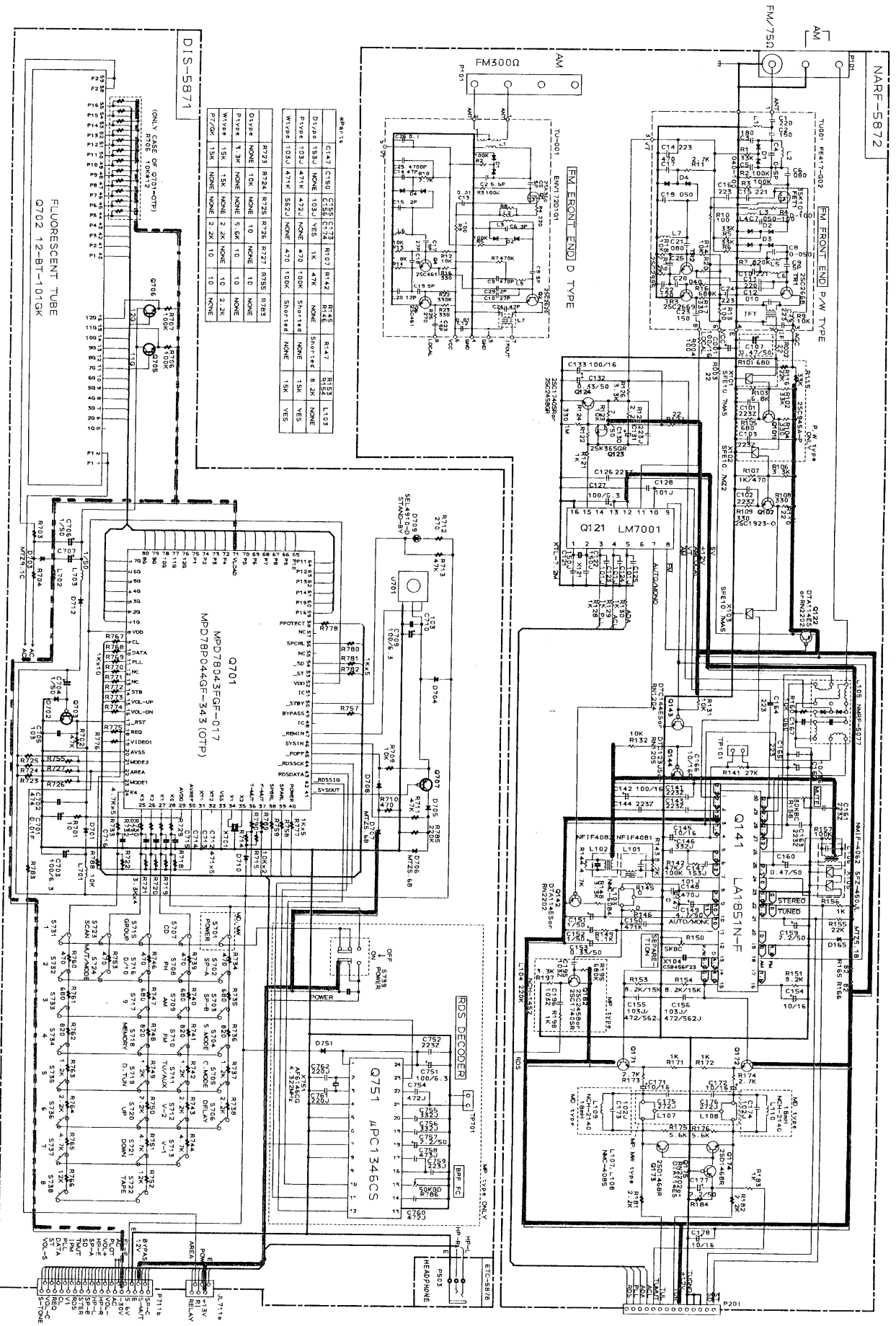

MPD715

C147	C150	C155	C172	R107	R142	R145	R147	R152	L103
153J	NONE	100J	YES	1K	47K	NONE	SHORTE	8.2K	NONE
PLAYE	103J	471K	472J	NONE	470	100K	SHORTE	NONE	15K
WYPR	103J	471K	522J	NONE	470	100K	SHORTE	NONE	15K

R723	R724	R725	R726	R727	R728	R729	R730
NONE	10K	NONE	10	NONE	10	NONE	10
PLAYE	3.3K	NONE	5.6K	10	10	NONE	10
WYPR	15K	15K	NONE	2.2K	NONE	10	2.2K

ONKYO CORPORATION

International Sales Div. : 31 Sankyo-bld. 3-8-5, Asakusabashi, Taito-ku, TOKYO 111, JAPAN
TEL : 03-5820-5865 FAX : 03-5820-5869

ONKYO U.S.A. CORPORATION
200 Williams Drive, Ramsey, N.J. 07446, U.S.A.
TEL : 201-825-7950 FAX : 201-825-8150

ONKYO EUROPE ELECTRONICS GmbH
Industriestrasse 18-20, 82110 Germering, GERMANY
TEL : 089 84 93 20 FAX : 089 84 93 226

ONKYO FRANCE
Immeuble Le Diamant, Domaine Technologique de Saclay, 4 Rue Rene Razel, 91892 SACLAY, FRANCE
TEL : (1) 69 33 14 00 FAX : (1) 69 41 35 84