

# ONKYO SERVICE MANUAL

## QUARTZ SYNTHESIZED TUNER AMPLIFIER MODEL TX-SV303PRO



Black model

BHMD, BHMDN, BHUD, BHUDN	120V AC, 60Hz
--------------------------	---------------

**SAFETY-RELATED COMPONENT WARNING!!**  
 COMPONENTS IDENTIFIED BY MARK **Δ** ON THE SCHEMATIC DIAGRAM AND IN THE PARTS LIST ARE CRITICAL FOR RISK OF FIRE AND ELECTRIC SHOCK. REPLACE THESE COMPONENTS WITH ONKYO PARTS WHOSE PART NUMBERS APPEAR AS SHOWN IN THIS MANUAL.  
 MAKE LEAKAGE-CURRENT OR RESISTANCE MEASUREMENTS TO DETERMINE THAT EXPOSED PARTS ARE ACCEPTABLY INSULATED FROM THE SUPPLY CIRCUIT BEFORE RETURNING THE APPLIANCE TO THE CUSTOMER.

### TABLE OF CONTENTS

- Specifications..... 2
- Service procedures..... 3
- Exploded view..... 4
- Parts list..... 5
- Block diagram..... 6
  - Tuner section..... 6
  - Amplifier section..... 7
- Microprocessor descriptions..... 8
- IC block diagrams and descriptions..... 11
- Adjustment procedures..... 22
- Printed circuit board view from bottom side..... 25
- Schematic diagram..... 31
  - Connection diagram of microprocessor..... 31
  - Tuner and video sections..... 33
  - Audio section..... 35
  - Surround section..... 37
- Printed circuit board-parts list..... 39
- Packing view..... 44



# SPECIFICATIONS

## AMPLIFIER SECTION

Power Output:	Stereo mode 80 watts per channel min. RMS. at 8 ohms, both channels driven, from 20Hz to 20,000Hz, with no more than 0.08% total harmonic distortion. Surround/Multi mode 75 watts per channel min. RMS. at 8 ohms both channels driven, from 20Hz to 20,000Hz, with no more than 0.08% total harmonic distortion. (FRONT) 12 watts per channel min. RMS. at 8 ohms 1,000Hz with no more than 0.8% total harmonic distortion. (REAR or REMOTE)
Total Harmonic Distortion:	0.08% at rated power (FRONT)
IM Distortion:	0.08% at rated power (FRONT)
Damping Factor:	60 at 8 ohms (FRONT)
Sensitivity and Impedance:	Phono: 2.5mV/50 kohms CD/Tape Play: 150mV/50 kohms Tape Rec: 150mV/2.2 kohms Pre out (CENTER): 1V, 2.2 kohms
Phono Overload:	120mV RMS. at 1,000 Hz, 0.08 % THD.
Frequency Response:	20 to 30,000 Hz, +/-1 dB
RIAA Deviation:	20 to 20,000 Hz, +/-0.8 dB
Tone Control:	BASS: +/-10 dB at 100 Hz TREBLE: +/-10 dB at 10,000 Hz
Signal to Noise Ratio:	PHONO: 80 dB (IHF A, 5mV input) CD/TAPE: 100 dB (IHF A)
Muting:	- ∞ dB

---

## VIDEO SECTION

Signal sensitivity and impedance  
VDP/VCR normal input, output: 1 Vp-p, 75 ohms

## TUNER SECTION

<b>FM:</b>		<b>AM:</b>	
Tuning Range:	87.5 – 108.0MHz (100kHz steps)	Tuning Range:	530 – 1710kHz (10kHz steps)
Usable Sensitivity:	Mono: 11.2dBf, 2.0μV Stereo: 17.2dBf, 4.0μV	Usable Sensitivity:	30μV
50dB Quieting Sensitivity:	Mono: 17.2dBf, 4.0μV Stereo: 37.2dBf, 40μV	Image Rejection Ratio:	40dB
Capture Ratio:	1.5dB	IF Rejection Ratio:	40dB
Image Rejection Ratio:	40dB	Signal-to-Noise Ratio:	40dB
rF Rejection Ratio:	90dB	Total Harmonic Distortion:	0.7%
Signal-to-Noise Ratio:	Mono: 73dB Stereo: 67dB		
Alternate Channel Attenuation:	55dB		
AM Suppression Ratio:	50dB		
Total Harmonic Distortion:	Mono: 0.15% Stereo: 0.25%		
Frequency Response:	30 – 15,000Hz ±1.5dB		
Stereo Separation:	45dB at 1kHz/30dB at 100 – 10,000Hz		
Muting Level:	17.2dBf, 4μV		

## GENERAL

Power Supply:	AC120V, 60Hz
Dimensions (W x H x D):	455 x 140 x 331.5 mm 17-15/16" x 5-7/8" x 13-1/16"
Weight:	9.9kg (21.8lbs)

Specifications and features are subject to change without notice.

# SERVICE PROCEDURES

## 1. Replacing the fuses

For continued protection against fire hazard, replace only with same type and same rating fuse.

Circuit no.	Part no.	Description
F901	252051	△ 6A ST-6,Primary fuse
F904, F905	252051	6A ST-6,Secondary fuse

## 2. Change of FM/AM band step.

(FM)

BAND STEP	R723	J751
100kHz→50kHz	Addition	Open
50kHz→100kHz	Eliminated	Short

(AM)

BAND STEP	R721	J749
10kHz→ 9kHz	Eliminated	Short
9kHz→10kHz	Addition	Open

In R721 and R723 Carbon resistor 100kΩ (Part No.417341044) are used.

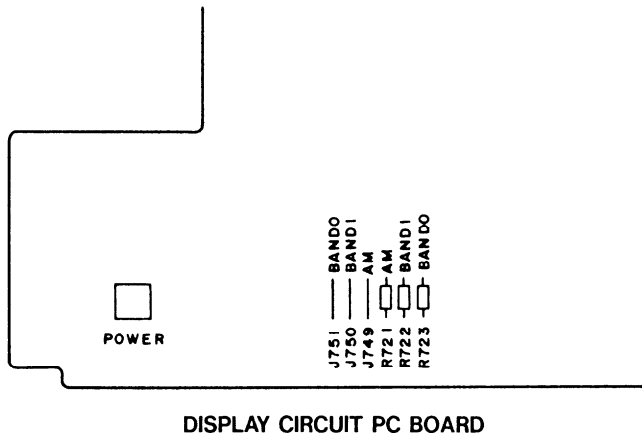
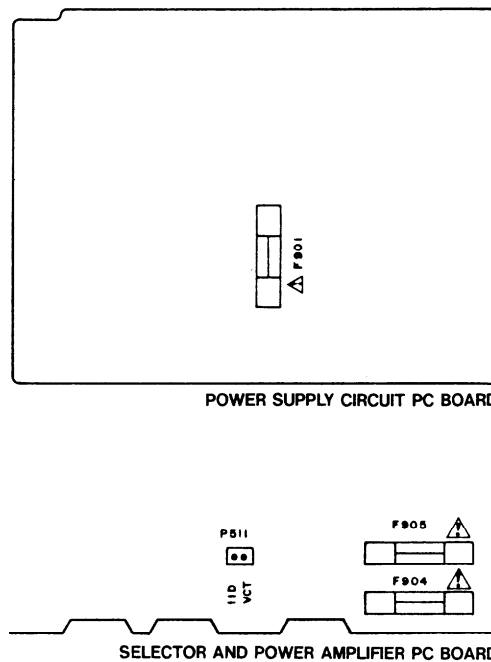

## 3. Memory preservation

This unit does not require memory preservation batteries. A built-in memory power back-up system preserves contents of the memory during power failures and even when the unit is unplugged. The unit must be plugged in and the power switch turned on and off once in order to charge the back-up system. Note that since this is not a permanent memory the power switch must be turned on and off a few times each month to keep the back-up system operative. The period of time during which memory contents are preserved after power has last been turned off varies depending on climate and placement of the unit. On the average, memory contents are protected over a period of 3 to 4 weeks (a minimum of 2 weeks) after the last time power has been turned off. This period is shorter when the unit is exposed to very high humidity or used in an area with an extremely humid climate.

## 4. Safety-check out

(Only U.S.A. model)

After correcting the original service problem perform the following safety check before releasing the set to the customer.

Connect the insulating-resistance tester between the plug of power supply cord and terminal GND on the back panel. Specifications: 3.3 Mohm ±10% at 500V.

EXPLODED VIEW

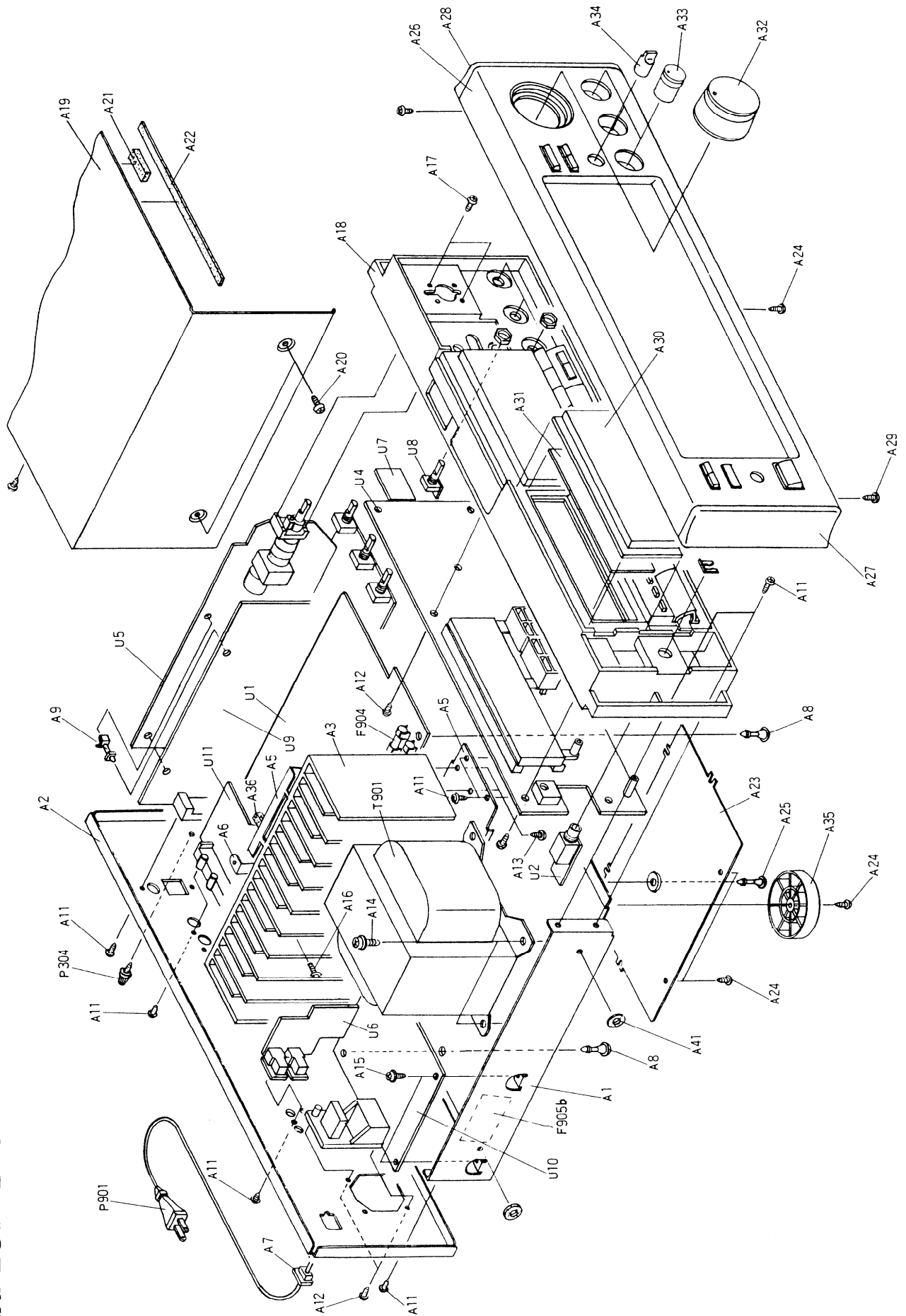

## PARTS LIST

REF. NO.	PART NO.	DESCRIPTION	REF. NO.	PART NO.	DESCRIPTION
A1	27100239AY	Chassis	F901	252051	6A ST-6,Primary fuse
A2	27121616Y	Rear panel	F904	252051	6A ST-6,Secondary fuse
A3	27160287	Radiator	F905	252051	6A ST-6,Secondary fuse
A4	27141474AY	Bracket SH	F905b	29360626-1	Rating label, fuse
A5	27130653Y	Bracket H	JL701	2041322010	NCFC1-322010,Flat cable
A6	27141498Y	Bracket S	P304	25060044	Terminal GND
A7	27300750	Bushing	P901	253163Y or 253174Y	AS-UC-6 #18, Power supply cord
A8	27190657	KGLS-18RT,Holder	Q505,Q506	2201653, 2201654, 2201655, 2202272 or 2202273	2SC3856-O, 2SC3856-Y, 2SC3856-P, 2SC3907-R or 2SC3907-O,Power amplifier transistors
A9	27190062	KGLS-12S,Holder	Q507,Q508	2201663, 2201664, 2201665, 2202262 or 2202263	2SA1492-O, 2SA1492-Y, 2SA1492-P, 2SA1516-R or 2SA1516-O,Power amplifier transistors
A10	801433	3SMS10W.SW+14B(BC),Sems self-tapping screw	T901	2300666	NPT-1110D,Power transformer
A11	834430088	3TTS+8B(BC),Self-tapping screw	U1	1A377587-5	NAAF-4187-5,Selector and power amplifier pc board ass'y
A12	833430080	3TTP+8B(BC),Self-tapping screw	U2	1A377588-5	NAETC-4188-5,Headphone terminal pc board ass'y
A13	834430108	3TTS+10B(BC),Self-tapping screw	U4	1A377589-5	NADIS-4189-5,Display circuit pc board ass'y
A14	830440089	4TTC+8C(BC),Self-tapping screw	U5	1A377590-5	NAAF-4190-5,Volume circuit pc board ass'y
A15	831130088	3TTW+8B,Self-tapping screw	U6	1A377591-5	NADG-4191-5,RI/MR terminal pc board ass'y
A16	82143015	3P+15FN(BC),Pan head screw	U7	1A377592-5	NASW-4192-5,Operation switch pc board ass'y
A17	82143006	3P+6FN(BC),Pan head screw	U8	1A377593-5	NAETC-4193-5,Input balance volume pc board ass'y
A18	27110718Y	Front bracket ass'y	U9	1A377594-5	NARF-4194-5,Tuner circuit pc board ass'y
A19	28184476AY	Top cover	U10	1A377595-5	NAPS-4195-5,Power supply circuit pc board ass'y
A20	834430088	3TTS+8B(BC),Self-tapping screw	U11	1A377596-5	NAAF-4196-5,Video and sub amplifier pc board ass'y
A21	28141132	6×60×40,Cushion			
A22	28141132	0.5×390×14,Cushion			
A23	27170280AY	Bottom panel			
A24	834430088	3TTS+8B(BC),Self-tapping screw			
A25	27190657	KGLS-18RT,Holder			
A26	1A377701K	Front panel ass'y			
A27	28125234BY	End cap L			
A28	28125235BY	End cap R			
A29	833430080	3TTP+8B(BC),Self-tapping screw			
A30	28191596A	Clear plate			
A31	28133262Y	Back plate			
A32	28324372	Knob VOLUME			
A33	28324376A	Knob TONE			
A34	28324378	Knob IB			
A35	27175251 or 27175251-1	Leg			

NOTE:  
THE COMPONENTS IDENTIFIED BY MARK **▲** ARE  
CRITICAL FOR RISK OF FIRE AND ELECTRIC SHOCK.  
REPLACE ONLY WITH PART NUMBER SPECIFIED.

# BLOCK DIAGRAM TUNER SECTION

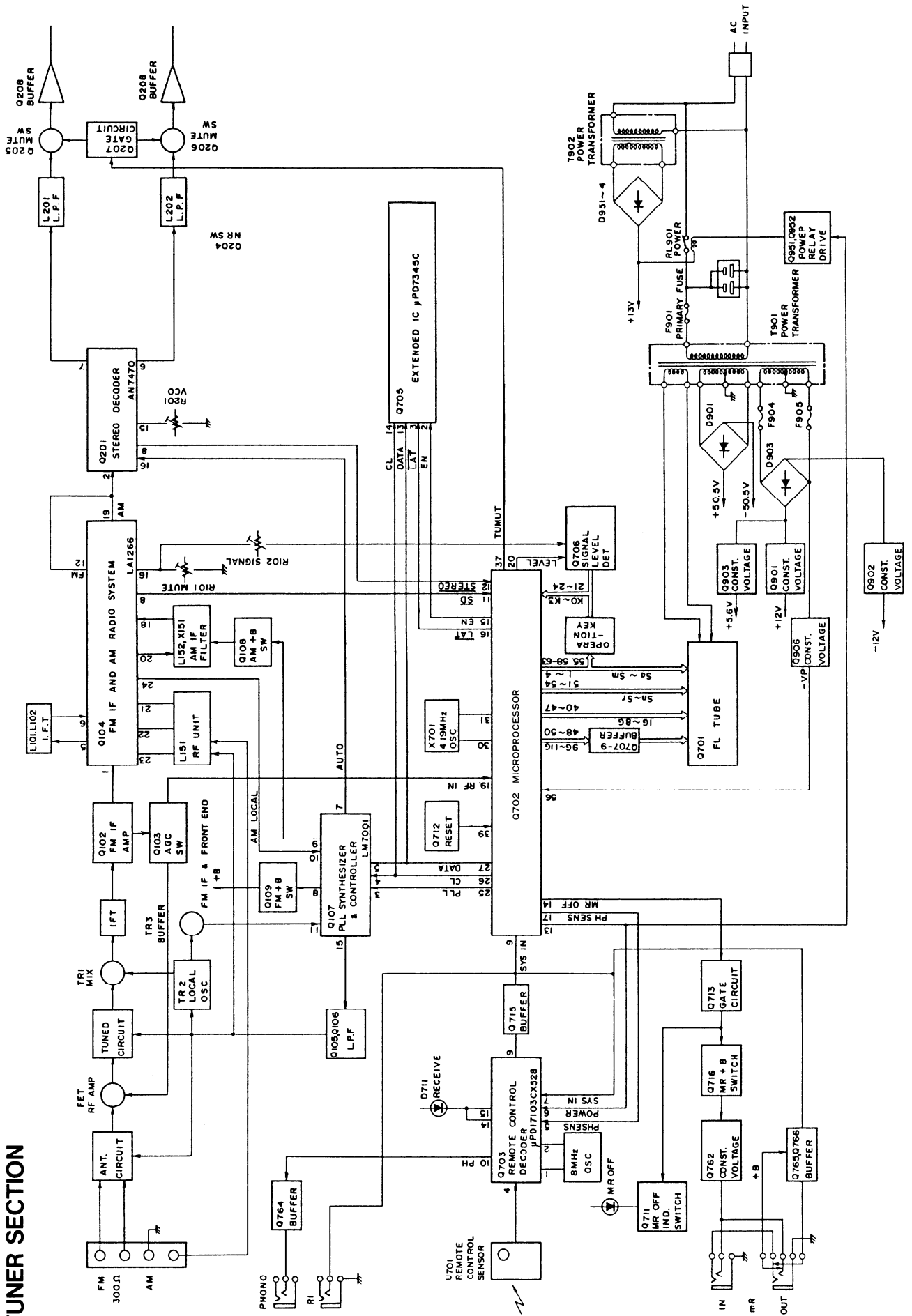

# BLOCK DIAGRAM AMPLIFIER SECTION

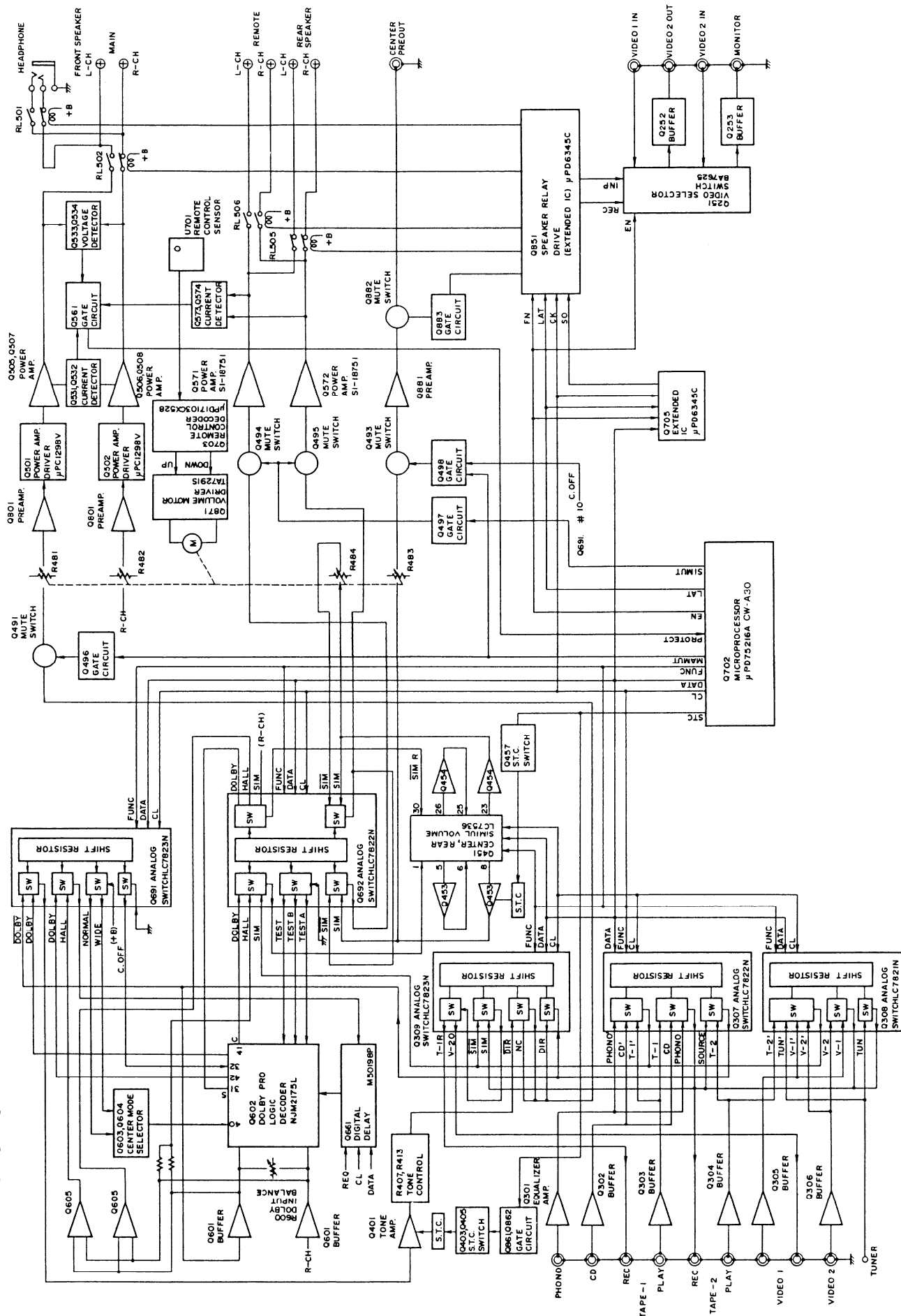





**Terminal Description**

Pin No.	Symbol	Description												
1	Sd	Segment and key scan output terminals. "H" when active.												
2	Sc													
3	Sb													
4	Sa													
5	POFF	This is the input terminal for detection of the stoppage of electric current. "L" when the stoppage of electric current.												
6	BAND0	Initializing input terminal for region setting of FM band.												
7	BAND1													
8	AM 10K	Initializing input terminal for region setting of AM band.												
9	SYS IN	System code input terminal."H" when active.												
10	PROTECT	Protection circuit operation detection input terminal. "H" when active.												
11	SD	Broadcast detection input terminal."L" when active. Control the stop of auto tuning and output TU MUT(#37).												
12	STEREO	Stereo broadcast detection input terminal. "L" when stereo broadcast.												
13	POWER	Power control output terminal."H" when the power turns on.												
14	MR	MR control output terminal. "H" when MR turns on.												
15	EN	Connect the terminal EN of the extended IC $\mu$ PD6345C.(Q705,Q851)												
16	LAT	Connect the terminal LAT of the extended IC $\mu$ PD6345C.												
17	PHONO	Phono control output terminal.												
18	S.TONE	SELECTIVE TONE control output terminal. "H" when this switch turns on.												
19	RF IN	RF mode input terminal. <table border="1" style="margin-left: 20px;"> <tr> <td>RF IN</td> <td>RF MODE</td> </tr> <tr> <td>L</td> <td>LOCAL</td> </tr> <tr> <td>H</td> <td>DX</td> </tr> </table> Control the terminals LOCAL and DX of the extended IC.	RF IN	RF MODE	L	LOCAL	H	DX						
RF IN	RF MODE													
L	LOCAL													
H	DX													
20	LEVEL	Signal level input control output terminal.The signal level is inputed to terminals K0-K3 when this terminal is the high level.												
21	K0	Key scan input terminals when pin 20 is low."H" when active. Signal level input terminal when pin 20 is high. <table border="1" style="margin-left: 20px;"> <thead> <tr> <th>Key input of L</th> <th>Signal level</th> </tr> </thead> <tbody> <tr> <td>none</td> <td>LEVEL0</td> </tr> <tr> <td>K0</td> <td>LEVEL1</td> </tr> <tr> <td>K0,K1</td> <td>LEVEL2</td> </tr> <tr> <td>K0,K1,K2</td> <td>LEVEL3</td> </tr> <tr> <td>K0,K1,K2,K3</td> <td>LEVEL4</td> </tr> </tbody> </table>	Key input of L	Signal level	none	LEVEL0	K0	LEVEL1	K0,K1	LEVEL2	K0,K1,K2	LEVEL3	K0,K1,K2,K3	LEVEL4
Key input of L	Signal level													
none	LEVEL0													
K0	LEVEL1													
K0,K1	LEVEL2													
K0,K1,K2	LEVEL3													
K0,K1,K2,K3	LEVEL4													
22	K1													
23	K2													
24	K3													
25	PLL	Connect to the terminal CE of PLL IC (LM7001 Q107).												
26	CL	Connect to the terminal CL of PLL IC,terminal CL of analogue switches(Q307,308, Q309,Q601,Q692),terminal SECK of digital delay (Q661) and terminal CLK of electro volume. (Q451)												
27	DATA	Connect to the terminal DATA of PLL IC,terminal DI of analogue switches,terminal SEDATA of digital delay,terminal SIN of extended IC and terminal CLK of electro volume. (Q451)												

**FM band setting**

BAND1	BAND0	REGION	FREQUENCY RANGE	CH. SPACE
0	0	U.S.A.	87.5-108.0MHz	50kHz
0	1	Europe	87.50-108.00MHz	50kHz
1	0	Saudi Arabia	87.50-108.00MHz	50kHz
1	1	Japan	76.0-90.0MHz	100kHz

**AM band setting**

AM10K	REGION	FREQUENCY RANGE	CH. SPACE
1	U.S.A.	530-1710kHz	10kHz
0	Saudi Arabia	531-1602kHz	9kHz
0	Europe	522-1611kHz	9kHz

Pin No.	Symbol	Description
28	CE	Connect to the terminal CE of analogue switches and terminal CE of electro volume.
29	LED	LED indicator control output terminal.
30	X1	Ceramic oscillator connection terminal for main system clock.
31	X2	Connect to the 4.19MHz ceramic oscillator.
32	VSS	Ground terminal.
33	XT1	Ceramic oscillator connection terminal for sub system clock.
34	XT2	Not used.
35	INP MUT	Audio muting output terminal when input selector change over.
36	SIM MUT	SIM muting output terminal when input selector change over.
37	TU MUT	Tuner muting output terminal."H" when active.
38	REQ/MODE	Connect to the terminal REQ of digital delay.
39	RESET	Reset input terminal."L"when active.
40	D1	Digit output terminals."H" when active.
41	D2	
42	D3	
43	D4	
44	D5	
45	D6	
46	D7	
47	D8	
48	D9	
49	D10	
50	D11	
51	So	Segment output terminals."H" when active.
52	Sr	
53	Sp	
54	Sn	
55	Sm	
56	VLOAD	Pull-down resistor connection terminal of FIP controller/driver.
57	VPRE	Power supply terminal of output buffer of FIP controller/driver.
58	Sk	Segment and key scan output terminals. "H" when active.
59	Sj	
60	Sh	
61	Sg	
62	Sf	
63	Se	
64	VDD	

## Key Matrix

No.	No.	24	23	22	21
		K3	K2	K1	K0
4	Sa	SLEEP	SPEAKER REMOTE	SPEAKER MAIN	POWER
3	Sb	DELAY TIME	SURROUND MODE	CENTER MODE	MR
2	Sc	TAPE-2	TAPE-1	VIDEO-2	VIDEO-1
1	Sd	CD	PHONO	AM	FM
63	Se		S.DIRECT	SIM	REC OUT
62	Sf	4	3	2	1
61	Sg	8	7	6	5
60	Sh	CLASS SCAN	D.TUNING	0	9
59	Sj	UP	DOWN	MEMORY	MUTE/MODE
58	Sk	CLASS-D	CLASS-C	CLASS-B	CLASS-A
55	Sm	CENTER OFF	SELECTIVE TONE	CLASS-F	CLASS-E

# IC BLOCK DIAGRAMS AND DESCRIPTIONS

## Q104

### LA1266 (FM IF and AM Radio System)

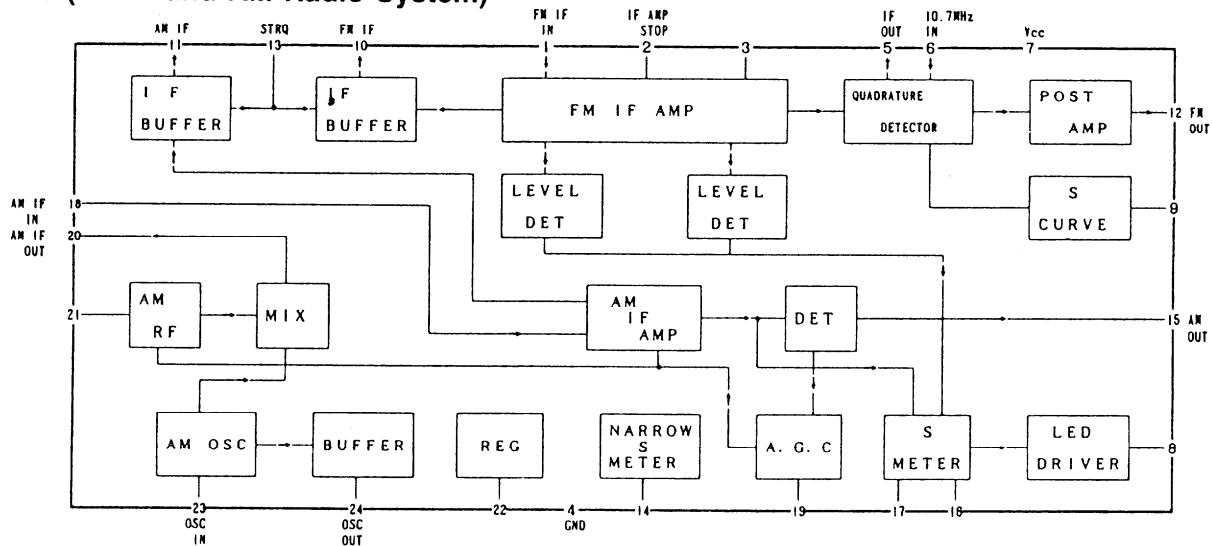

## Q201

### AN7470 (FM Stereo Decoder)

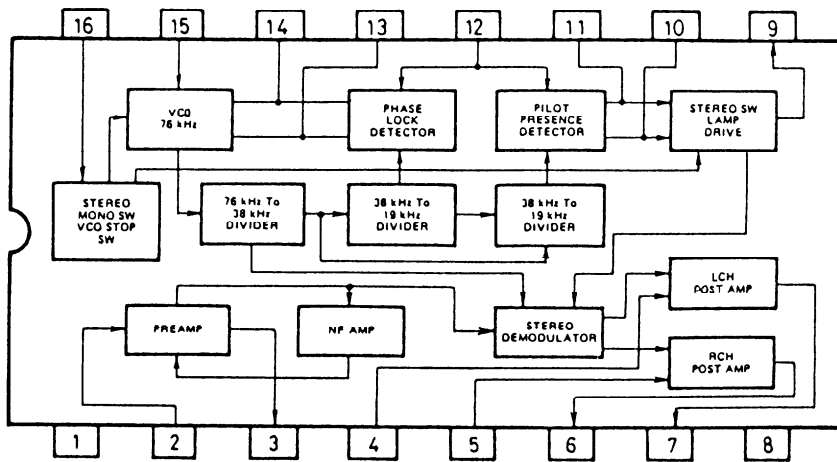

## Q251

### BA7625 (Video Selector Switch)

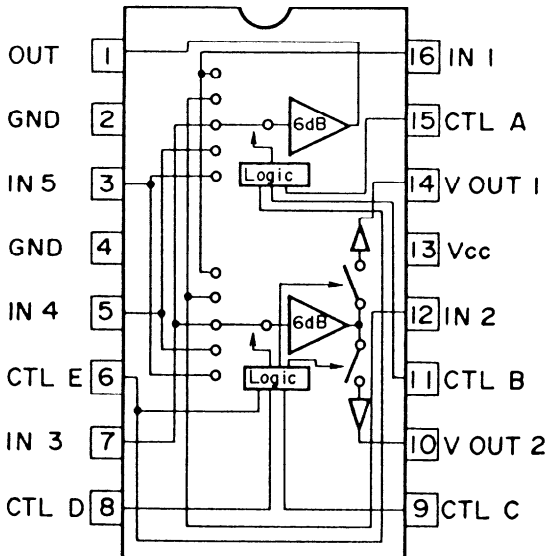

#15	#11	#6	#1
A	B	E	MONITOR OUT
L	L	X	IN1
H	L	X	IN2
L	H	X	IN3
H	H	L	IN4
H	H	H	IN5

X: Don't care

#9	#8	#6	#14
C	D	E	VOUT 1
L	L	X	
H	L	X	
L	H	X	
H	H	L	
H	H	H	

#15	#11	#6	#10
A	B	E	VOUT 2
L	L	X	IN1
H	L	X	
L	H	X	IN3
H	H	L	IN4
H	H	H	IN5

## Q107 LM7001 (PLL Synthesizer and Controller)

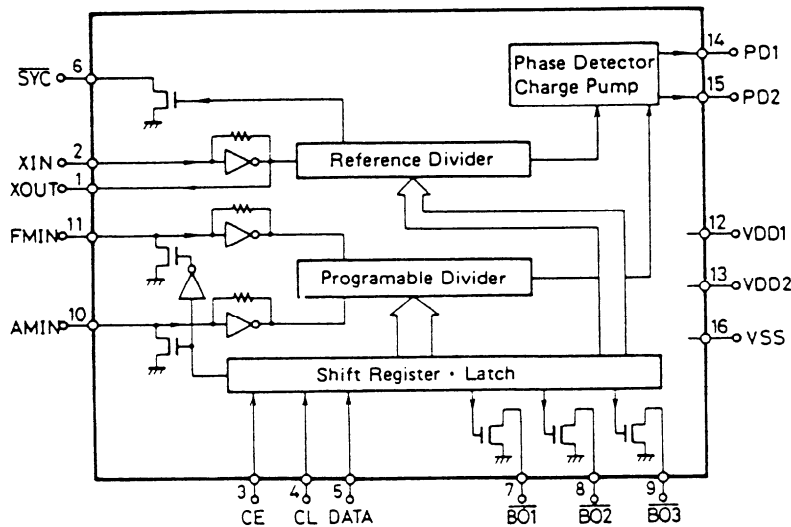

Pin No.	Terminal	Description
1	XOUT	Connect to the 7.2 MHz crystal oscillator.
2	XIN	
3	CE	Chip enable terminal. Connect to the PLL terminal of microprocessor.
4	CL	Serial clock input terminal. Connect to the CLOCK terminal of microprocessor.
5	DATA	Serial data input terminal. Connect to the DATA terminal of microprocessor.
6	$\overline{\text{SYN}}$	Not used.
7	$\overline{\text{AUTO/MONO}}$	AUTO/MONO selection output terminal. "L" when AUTO.
8	$\overline{\text{FM}}$	FM band control output terminal. "L" when FM.
9	$\overline{\text{AM}}$	AM band control output terminal. "L" when AM.
10	AMIN	AM local oscillator input terminal.
11	FMIN	FM local oscillator terminal.
12	VDD 1	Power supply terminal for back-up.
13	VDD 2	Power supply terminal.
14	PD1	Charge pump output of the phase detector which constitutes the PLL. High level is output when the divided local oscillator frequency is high than the reference frequency. In the opposite case, low level is output. Floating occurs when the frequencies matched. The output is applied to the variable capacitor diode in the local oscillator through the low pass filters.
15	PD2	
16	Vss	Ground terminal.

## Q307, Q692 LC7822N (Analogue switch)

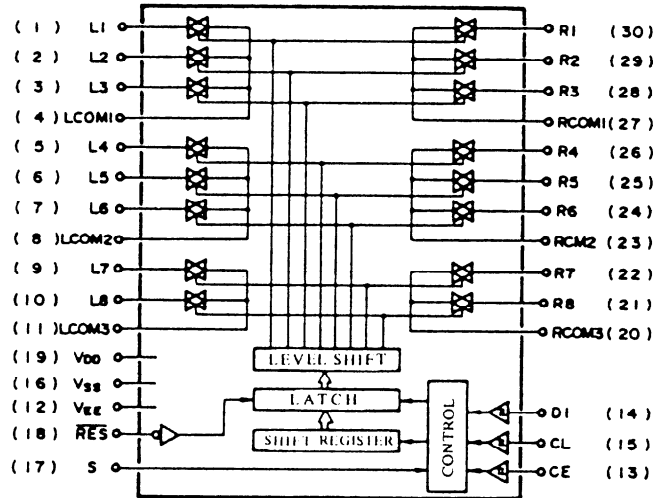

### Q307

Pin No.	Terminal	Description	Pin No.	Terminal	Description	
1	PHONO'	Input/output terminals of audio signal of left channel.	16	Vss	Ground terminal.	
2	CD'		17	S	Selector terminal	
3	TAPE-1		18	RES	Reset terminal. When power is turned on, the condition of the analog switch is not determined, but when this terminal is "L", all analog switches are off.	
4	L COM 1		19	VDD	Power supply terminal. (+15V)	
5	TAPE-1		20	R COM 3	Input/output terminals of audio signal of right channel.	
6	CD		21	TAPE-2		
7	PHONO		22	SOURCE		
8	L COM 2		23	R COM 2		
9	SOURCE		24	PHONO		
10	TAPE-2		25	CD		
11	L COM 3		26	TAPE-1		
12	Vss	Negative power supply terminal. (-15V)	27	R COM 1		Control to the inside analogue switch at the serial data.
13	CE	Chip enable terminal. Connect the terminal SEL of microprocessor.	28	TAPE-1'		
14	DI	Serial data input terminal. Connect the terminal DATA of microprocessor.	29	CD'		
15	CL	Serial clock input terminal. Connect the terminal CLOCK of microprocessor.	30	PHONO'		

### Q692

Pin No.	Terminal	Description	Pin No.	Terminal	Description		
1	DOLBY	Input/output terminals of audio signal of right channel when surround mode.	16	Vss	Ground terminal.		
2	HALL		17	S	Selector terminal		
3	SIM		Control the inside analogue switch at the serial data.	18	RES	Reset terminal. When power is turned on, the condition of the analog switch is not determined, but when this terminal is "L", all analog switches are off.	
4	L COM 1			19	VDD	Power supply terminal. (+15V)	
5	TEST			Not used.	20	R COM 3	Input/output terminals of audio signal of right channel when mode SIM.
6	TEST B				21	SIM	
7	TEST A			22	SIM		
8	L COM 2			23	R COM 2	Dolby pro logic control signal.	
9	SIM		Input/output terminals of audio signal of center channel when mode SIM.	24	TEST A	Control the inside analogue switch at the serial data.	
10	SIM			25	TEST B		
11	L COM 3			26	TEST		
12	Vss	Negative power supply terminal. (-15V)	27	R COM 1	Input/output terminals of audio signal of left channel when surround mode.		
13	CE	Chip enable terminal. Connect the terminal SEL of microprocessor.	28	SIM			
14	DI	Serial data input terminal. Connect the terminal DATA of microprocessor.	29	HALL		Control to the inside analogue switch at the serial data.	
15	CL	Serial clock input terminal. Connect the terminal CLOCK of microprocessor.	30	DOLBY			

**Q308**  
**LC7821N (Analogue switch)**

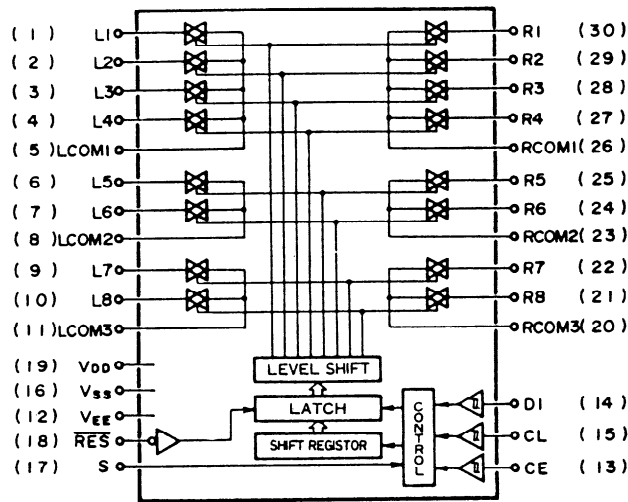

**Q308**

Pin No.	Terminal	Description	Pin No.	Terminal	Description
1	TAPE-2'	Input/output terminals of audio signal of right channel. Control to the inside analogue switch at the serial data.	16	Vss	Ground terminal.
2	TUNER'		17	S	Selector terminal
3	VIDEO-1'		18	RES	Reset terminal. When power is turned on, the condition of the analog switch is not determined, but when this terminal is "L", all analog switches are off.
4	VIDEO-2'				
5	L COM 1		19	VDD	Power supply terminal. (+15V)
6	VIDEO-2		Input/output terminals of audio signal of left channel. Control to the inside analogue switch at the serial data.	20	L COM 3
7	VIDEO-1			21	OFF
8	L COM 2			22	TUNER
9	TUNER			23	L COM 2
10	OFF			24	VIDEO-1
11	L COM 3			25	VIDEO-2
12	Vss	26		L COM 1	
13	CE	27		VIDEO-2'	
14	DI	28		VIDEO-1'	
15	CL	29		TUNER'	
		30	TAPE-2'		

Serial Data Composition

	A0	A1	A2	A3	SW1	SW2	SW3	SW4	SW5	SW6	SW7	SW8	
	Address				Switch change over								
Q306	0	1	0	1	TAPE-2'	TUNER'	VIDEO-1'	VIDEO-2'	VIDEO-2	VIDEO-1	TUNER		
Q307	0	0	1	1	PHONO'	CD'	TAPE-1'	TAPE-1	CD	PHONO	SOURCE	TAPE-2	
Q309	0	1	1	1	TAPE-1	VIDEO-2	SIM	SIM	DIRECT		DIRECT		
Q691	1	1	1	1	DOLBY	DOLBY	DOLBY	HALL	NORMAL	WIDE	CENTER OFF		TX-906
Q692	1	0	1	1	DOLBY	HALL	SIM	TEST	TESTA	TESTB	SIM	SIM	TX-906

**Q309, Q691**  
**LC7823N (Analogue switch)**

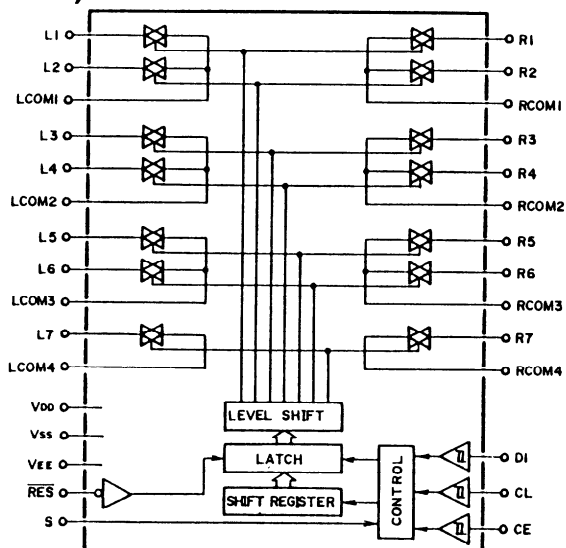

**Q309**

Pin No.	Terminal	Description	Pin No.	Terminal	Description
1	TAPE-1 REC	Recording output terminals.Control the analogue switch at the serial data.	16	Vss	Ground terminal.
2	VIDEO-2 OUT		17	S	Selector terminal
3	L COM 1		18	RES	Reset terminal.When power is turned on,the condition of the analog switch is not detrmind,but when this terminal iS "L",all analog switches are off.
4	SIM	Input/output terminals of audio signal of left channel when surround mode. Control the inside analogue switch at the serial data.	19	VDD	Power supply terminal.(+15V)
5	SIM		20	R COM 4	Input/output terminals of audio signal of right channel when surround mode. Control to the inside analogue switch at the serial data.
6	L COM 2		21	RIRECT	
7	DIRECT		22	R COM 3	
8	NC		23	NC	
9	L COM 3		24	DIRECT	
10	DIRECT		25	R COM 2	
11	L COM 4	26	SIM		
12	Vss	Negative power supply terminal. (-15V)	27	SIM	
13	CE	Chip enable terminal.Connect the terminal SEL of microprocessor.	28	R COM 1	Recording output terminals.Control the analogue switch at the serial data.
14	DI	Serial data input terminal.Connect the terminal DATA of microprocessor.	29	VIDEO-2 OUT	
15	CL	Serial clock input terminal.Connect the terminal CLOCK of microprocessor.	30	TAPE-1 REC	

**Q691**

Pin No.	Terminal	Description	Pin No.	Terminal	Description
1	DOLBY	Input/output terminals of audio signal of left channel when surround mode. Control the inside analogue switch at the serial data.	16	Vss	Ground terminal.
2	DOLBY		17	S	Selector terminal
3	L COM 1		18	RES	Reset terminal.When power is turned on,the condition of the analog switch is not detrmind,but when this terminal iS "L",all analog switches are off.
4	DOLBY		19	VDD	Power supply terminal.(+15V)
5	HALL		20	R COM 4	Input/output terminals of audio signal of right channel when surround mode. Control to the inside analogue switch at the serial data.
6	L COM 2		21	C. OFF	
7	NORMAL		22	R COM 3	
8	WIDE		23	WIDE	
9	L COM 3		24	NORMAL	
10	C. OFF		25	R COM 2	
11	L COM 4		26	HALL	
12	Vss	Negative power supply terminal. (-15V)	27	DOLBY	
13	CE	Chip enable terminal.Connect the terminal SEL of microprocessor.	28	R COM 1	
14	DI	Serial data input terminal.Connect the terminal DATA of microprocessor.	29	DOLBY	
15	CL	Serial clock input terminal.Connect the terminal CLOCK of microprocessor.	30	DOLBY	

# Q451 LC7536 (Electro Volume)

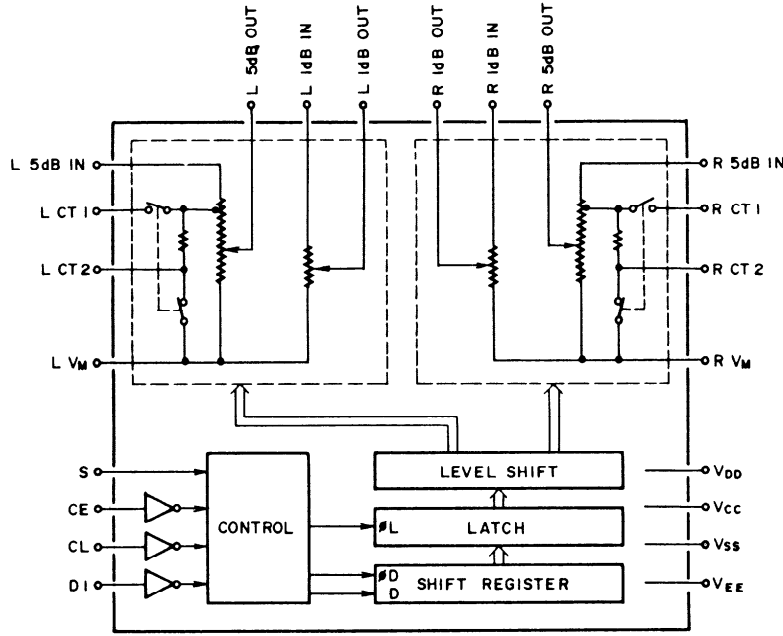

No.	TERMINAL	DESCRIPTION	No.	TERMINAL	DESCRIPTION
1	L 5dB IN	5dB step attenuator input terminal	17	CL	Serial data input terminal
3	L CT1	Terminal for loudness	18	DI	Serial data input terminal
4	L CT2	Terminal for loudness	19	CE	Serial data input terminal
5	L 5dB OUT	5dB step attenuator output terminal	21	VCC	Power supply terminal
6	L 1dB IN	1dB step attenuator input terminal	22	R VM	Common terminal of volume
8	L 1dB OUT	1dB step attenuator output terminal	23	R 1dB OUT	1dB step attenuator output terminal
9	L VM	Common terminal of volume	25	R 1dB IN	1dB step attenuator input terminal
10	VEE	Power supply terminal	26	R 5dB OUT	5dB step attenuator output terminal
12	S	Select terminal of address code during data format	27	R CT2	Terminal for loudness
13	VDD	Power supply terminal	28	R CT1	Terminal for loudness
14	VSS	Power supply terminal	30	R 5dB IN	5dB step attenuator input terminal

# Q501, Q502 μPC1298V (Power Amplifier Driver)

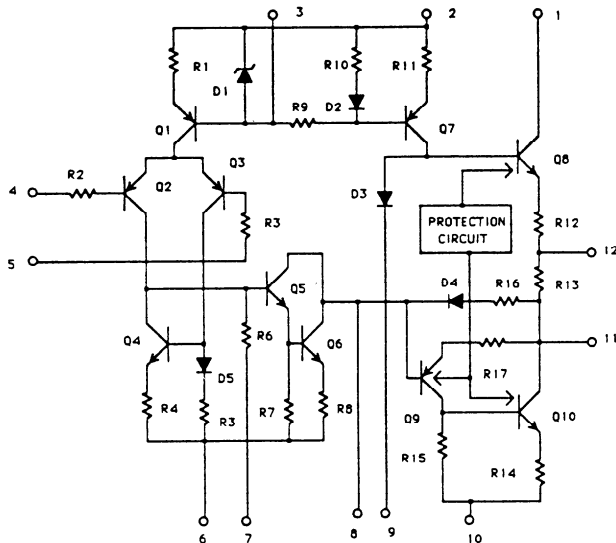



**Q602**  
**NJM2175L (Dolby Pro Logic Decoder)**

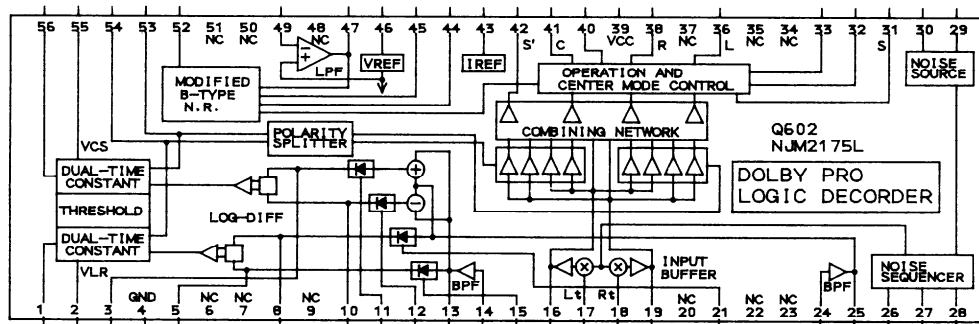

**Q661**  
**M50198P (Digital Delay)**

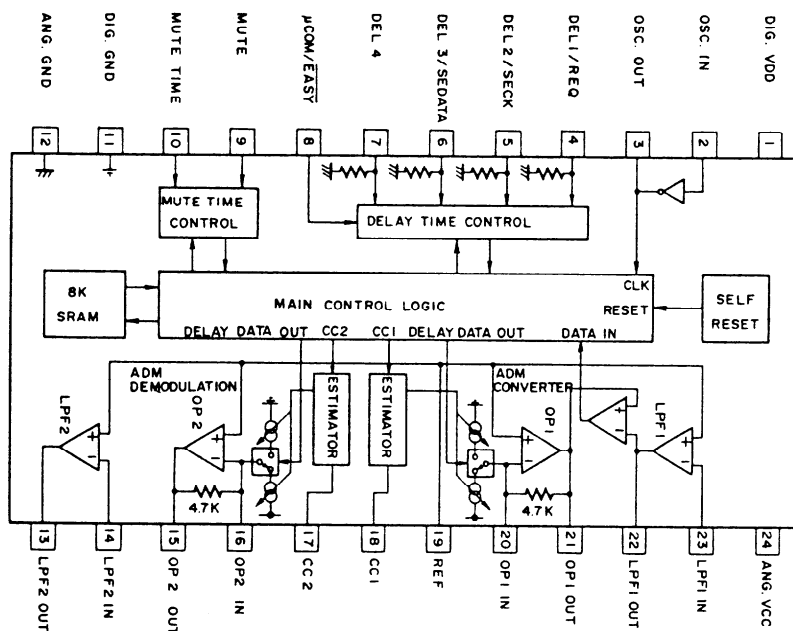

Pin no.	Symbol	Function
1	DIG GND	Power supply terminal of digital section
2	OSC. IN	Connect the 3.27MHz ceramic oscillator or external clock.
3	OSC. OUT	
4	DEL1/REQ	Terminal DEL1 when the easy mode. Terminal REQ when the microprocessor.
5	DEL2/SECK	Terminal DEL2 when the easy mode. Terminal SECK when the microprocessor.
6	DEL3/SEDATA	Terminal DEL3 when the easy mode. Terminal SEDATA when the microprocessor.
7	DEL4	80usec. mode control terminal.
8	COM/EASY	Microprocessor or easy mode changeover terminal
9	MUTE	Manual muting control terminal.
10	MUTE TIME	Auto muting time changeover terminal.
11	DIG. GND	Digital ground
12	ANG. GND	Analog ground
13	LPF2 OUT	Connect the secondary low pass filter between pins 13 & 14.
14	LPF2 IN	
15	OP2 OUT	Operation amplifier output terminal
16	OP2 IN	Operation amplifier input terminal
17	CC2	Current control
18	CC1	Current control
19	REF	Reference voltage.(2.5V)
20	OP1 IN	Operation amplifier input terminal
21	OP1 OUT	Operation amplifier outout terminal
22	LPF1 OUT	Connect the low pass filter between pins 22 and 23.
23	LPF1 IN	
24	ANG. VCC	Power supply terminal of analog section.

**Q701**  
**11-BT-107GK (Fluorescent Indicator Tube)**

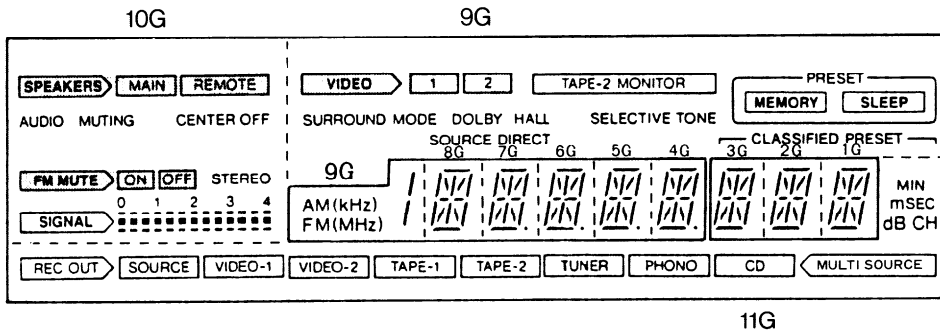

PIN NO.	51	50	49	48	47	46	45	44	43	42	41	40	39	38	37	36	35	34	33	32	31	30	29	28	27	26
CONNECTION	F2	F2	NP	NP	P1	P2	P3	P4	P5	P6	P7	P8	P9	P10	P11	P12	P13	P14	P15	NC	NP	NP	NP	NP	NP	NP
PIN NO.	25	24	23	22	21	20	19	18	17	16	15	14	13	12	11	10	9	8	7	6	5	4	3	2	1	
CONNECTION	NP	NP	NP	NP	NP	NC	NC	NC	NC	NC	11G	10G	9G	8G	7G	6G	5G	4G	3G	2G	1G	NP	NP	F1	F1	

	11G	10G	9G	8G	7G	6G	5G	4G	3G	2G	1G
P1	dB	AUDIO MUTING	TAPE-2 MONITOR	d	d	d	d	d	d	d	d
P2	CH	REMOTE	2	c	c	c	c	c	c	c	c
P3	mSEC	MAIN	1	b	b	b	b	b	b	b	b
P4	MIN	SPEAKERS	VIDEO	a	a	a	a	a	a	a	a
P5	MULTI SOURCE	CENTER OFF	SURROUND MODE	e	e	e	e	e	e	e	e
P6	Frame of CD	FM MUTE	DOLBY	f	f	f	f	f	f	f	f
P7	Frame of PHONO	ON	HALL	g	g	g	g	g	g	g	g
P8	Frame of TUNER	OFF	SELECTIVE TONE	h	h	h	h	h	h	h	h
P9	Frame of TAPE2	STEREO	SOURCE DIRECT	j	j	j	j	j	j	j	j
P10	Frame of TAPE1	S2	MEMORY	k	k	k	k	k	k	k	k
P11	Frame of VIDEO2	B1	SLEEP	m	m	m	m	m	m	m	m
P12	Frame of VIDEO1	B2	S1	n	n	n	n	n	n	n	n
P13	Frame of SOURCE	B3	AM(kHz)	p	p	p	p	p	p	p	p
P14	REC OUT	B4	FM(MHz)	r	r	r	r	r	r	r	r
P15	S3			-	o	o	o	o	-	-	-

## Q703 μPD17103CX-531 (Remote Control Decoder)

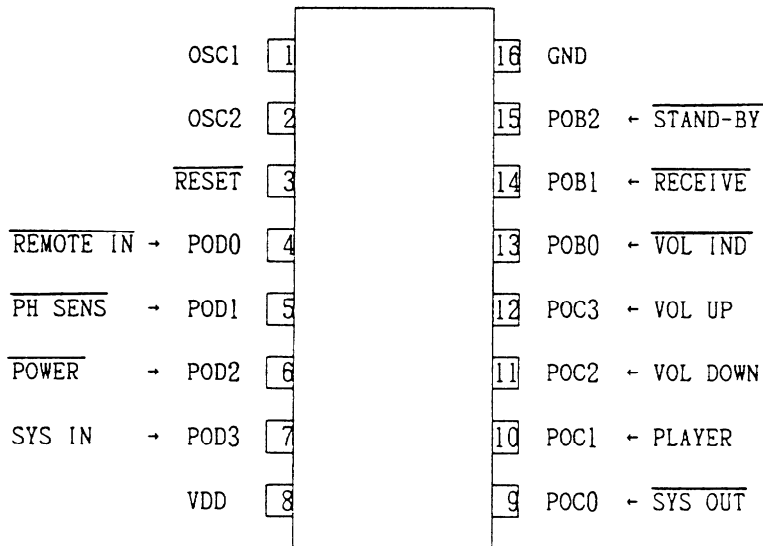
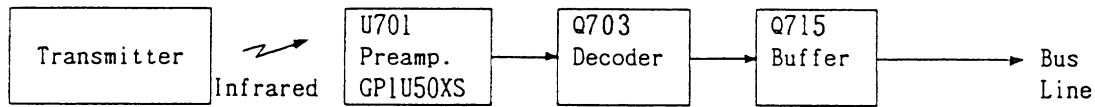

Pin No.	Symbol	Terminal	Description
1	OSC1	OSC	Connect to the 8.00MHz ceramic oscillator.
2	OSC2		
3	RES	$\overline{\text{RESET}}$	System reset terminal. Active low.
4	POD0	$\overline{\text{REMOTE IN}}$	Signal input terminal from preamp. for remote control. Active low.
5	POD1	PHONO SENS	Phono detection input terminal. Active low.
6	POD2	POWER	Stand-by detection input terminal. During low input, only the POWER code is decoded.
7	POD3	SYS IN	System code input terminal.
8	V <sub>DD</sub>	+B	Power supply terminal.
9	POC0	$\overline{\text{SYS OUT}}$	Output at this terminal are the custom code (16bits) remote control code input to REMOTE IN, data code (8bits), and the serial code (12bits) that has been converted corresponding to the decoded data code (8bits)
10	POC1	PLAYER	When the player PLAY/REEJECT is input, a high pulse of 200ms is output.
11	POC2	VOL DOWN	When the volume DOWN code is input, a high pulse of 120ms is output.
12	POC3	VOL UP	When the volume UP code is input, a high pulse of 120ms is output.
13	POB0	$\overline{\text{VOL IND}}$	During the output of VOLUME UP/DOWN, a pulse ( $\overline{\text{T}}\text{T}\overline{\text{T}}\text{T}$ )= 250ms) is output. (Not used.)
14	POB1	$\overline{\text{RECEIVE}}$	This is the display output for remote control reception. Output is low when decoded code is being recieved.
15	POB2	$\overline{\text{STAND-BY}}$	STAND-BY indication terminal.
16	V <sub>SS</sub>	GND	Ground terminal.

**Q705, Q851**  
**μPD6345C (Extended IC)**

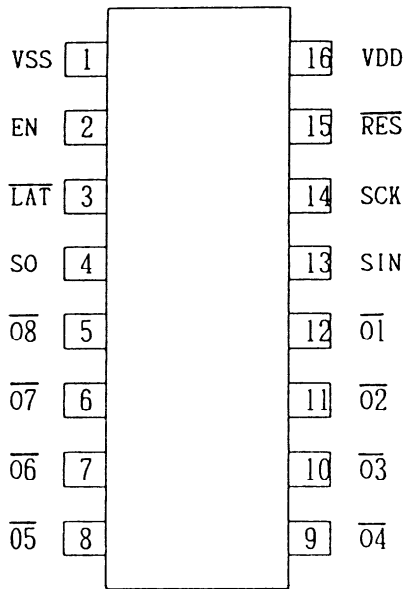

		Q705	Q851
Pin No.	Symbol	Description	Description
1	VSS	Ground terminal.	
2	EN	Chip enable input terminal. Connect to the terminal EN of the microprocessor. Active H.	
3	LAT	Latch input terminal. Connect to the terminal LAT of the microprocessor.	
4	SO	Serial data output terminal.	
5	O8	NR OFF indicator output terminal. Active low.	Headphone relay control output terminal. Active low.
6	O7	NR ON indicator output terminal. Active low.	Rear speaker relay control output terminal. Active low.
7	O6	HB OFF indicator output terminal. Active low.	Remote speaker relay control output terminal. Active low.
8	O5	HB ON indicator output terminal. Active low.	Main speaker relay control output terminal. Active low.
9	O4	LOCAL indicator output terminal. Active low.	Center preout muting control output terminal. Active low.
10	O3	DX indicator output terminal. Active low.	Not used.
11	O2	AUTO indicator output terminal. Active low.	Video selector switch control output terminal.
12	O1	MONO indicator output terminal. Active low.	Video selector switch control output terminal.
13	SIN	Serial data input terminal. Connect to the terminal DATA of the microprocessor.	
14	SCK	Serial clock input terminal. Connect to the terminal CLOCK of the microprocessor.	
15	RESET	Reset input terminal. Active L.	
16	VDD	Power supply terminal.	

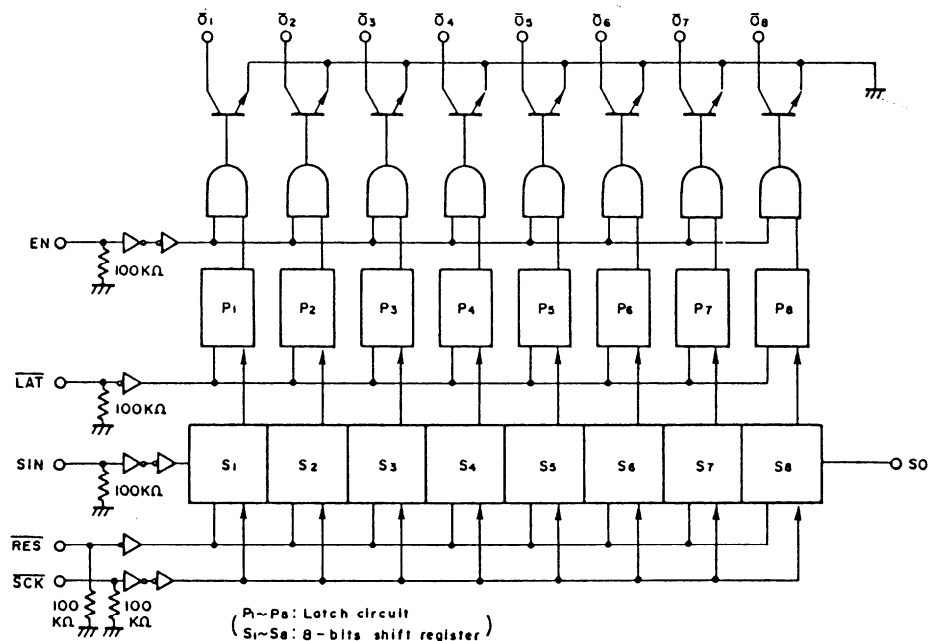

**Q706**  
**BA6125 (Signal meter driver)**

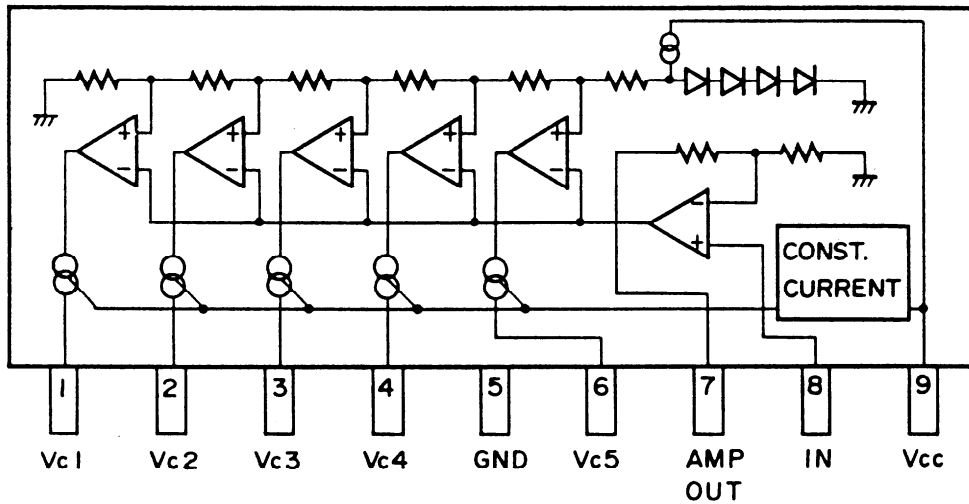

**Q871**  
**TA7291S (Volume driver)**

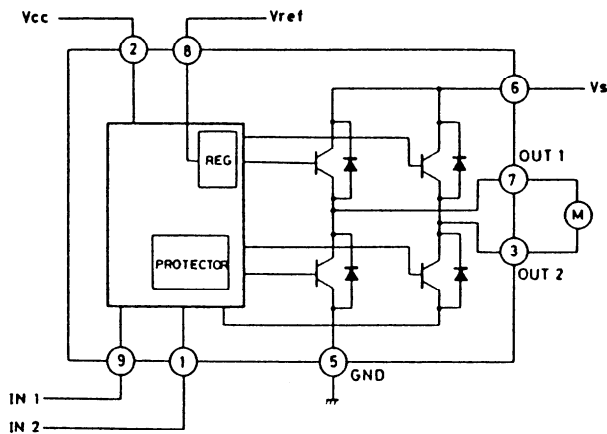

INPUT		OUTPUT		MODE
IN 1	IN 2	OUT 1	OUT 2	
0	0	∞	∞	STOP
1	0	H	L	CW/CCW
0	1	L	H	CCW/CW
1	1	L	L	BRAKE

CCW: Counter clockwise direction  
CW: Clockwise direction

**Q571, Q572**  
**SI-18751 (Power amplifier)**

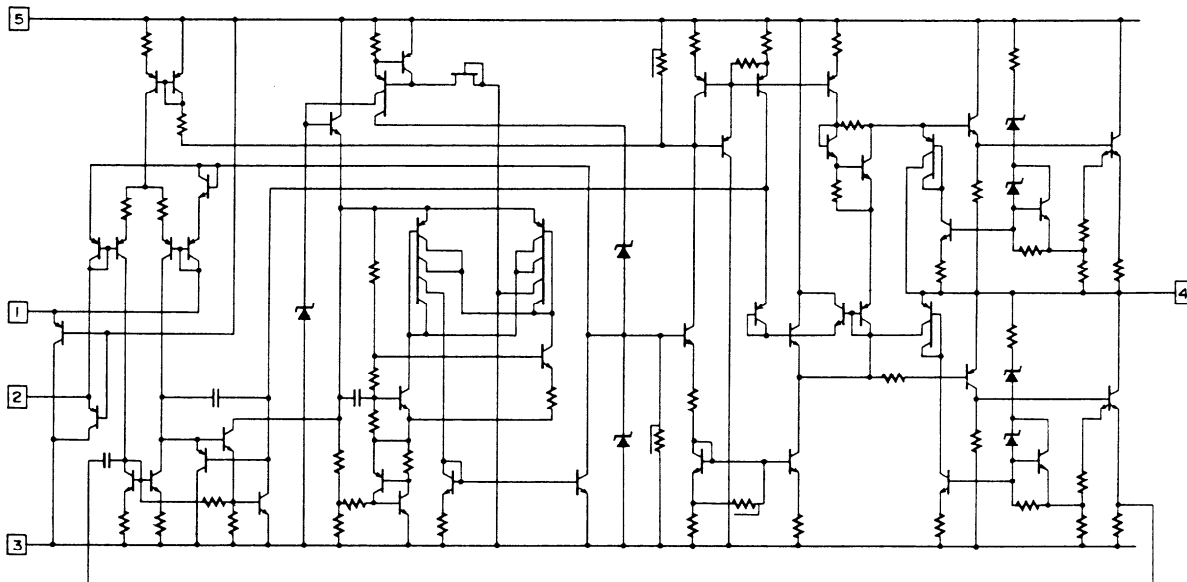

## ADJUSTMENT PROCEDURES

### • Preparation

#### 1. Input

FM mono: 1kHz, 75kHz devi., 60dB/μV  
 FM stereo: 1kHz, 75kHz devi., 60dB/μV  
 Pilot signal 19kHz 7.5kHz devi.  
 AM: 400Hz 30% mod.

#### 2. Outputs

Connect the non-inductive type resistors of 8ohms to the main speaker, remote speaker, and rear speaker terminals unless otherwise noted.

#### 3. Standard Knob Position

TAPE MONITOR 2 .....	OFF	SURROUND MODE .....	OFF
VOLUME .....	Maximum	CENTER MODE .....	WIDE
BASS/TREBLE/BALANCE/INPUT		DELAY TIME .....	20ms
BALANCE .....	Center	MULTI/REAR LEVEL .....	Center
MUTING .....	OFF		
REC SELECTOR .....	SOURCE		
INPUT SELECTOR .....	CD		
SPEAKERS .....	ON		
S.T.C. ....	OFF		

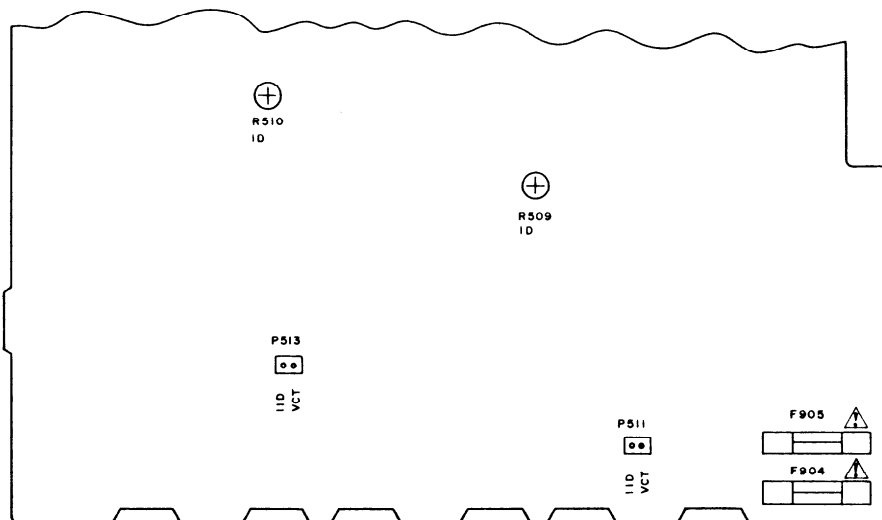

SELECTOR AND POWER AMPLIFIER PC BOARD

### Amplifier section

#### Idling Current Adjustment

Connect the DC voltmeter to the terminals IID and VCT on the pre., and main amplifier pc board. Adjust the semi-fixed resistors R509, and R510 so that indication of voltmeter is  $5 \pm 0.5\text{mV}$ .

NOTE: Adjust after switching on for 5 minutes.

**FM section**

Item	Step	Connection of instrument	FM SG output	Stereo modulator output	Tuning frequency	Output indicator	Adjustment point	Remarks
FM IF/RF	1					DC voltmeter	L101	
	2	Fig. 1	99.1MHz 1kHz, 75kHz devi. 65dB (60dB)		99.1MHz	AC voltmeter	IFT on the front end	FM MUTE/MODE switch: ON/STEREO Repeat the steps 1 and 3 until no further adjustment is necessary.
	3					Distortion analyzer	L102	
VCO		Fig. 2	99.1MHz, Ext 1kHz, 75kHz devi. 65dB (60dB)		99.1MHz	Frequency counter	R201	
Stereo Distortion	1	Fig. 3	99.1MHz, Ext mod., 65dB (60dB)	Channel L or R 1kHz	99.1MHz	Distortion analyzer	IFT on the front end	Don't turn more than ±18°
	2	Fig. 3	99.1MHz Ext modulation 65dB (60dB)	Channel L 1kHz Channel R 1kHz	99.1MHz	Channel R AC voltmeter Channel L AC voltmeter	R202	Maximum and same separation.
Muting Level		Fig. 3	99.1MHz 17.2dB (12dB)		99.1MHz	AUTO indicator	R101	
Signal Level		Fig. 3	99.1MHz 35dB (30dB)		99.1MHz	4th Signal indicator	R102	

**AM section**

Step	AM SG output	Tuning frequency	Output indicator	Adjustment point	Adjust for
1		530kHz	Digital DC voltmeter	OSC coil on RF block L151	1.2 ± 0.1V
2	600kHz 400Hz, 30% mod. 60dB/m	600kHz	AC voltmeter	RF coil on RF block L151	Maximum
3	990kHz 400Hz, 30% mod. 60dB/m	990kHz	AC voltmeter	L152	Maximum

Reference Specifications  
 FM tuned voltage: 87.5MHz - 108.00MHz  
 1.6 ± 0.4V - 8.0 ± 0.4V  
 AM tuned voltage: 530kHz 1.2 ± 0.3V  
 1710kHz 7.0 ± 0.5V  
 Auto stop level: AM: Less than 65dB/m  
 FM: Less than 16dB/μ

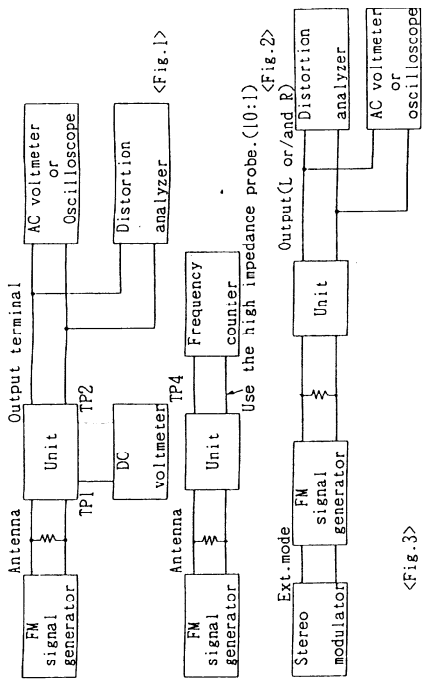

<Fig. 3>

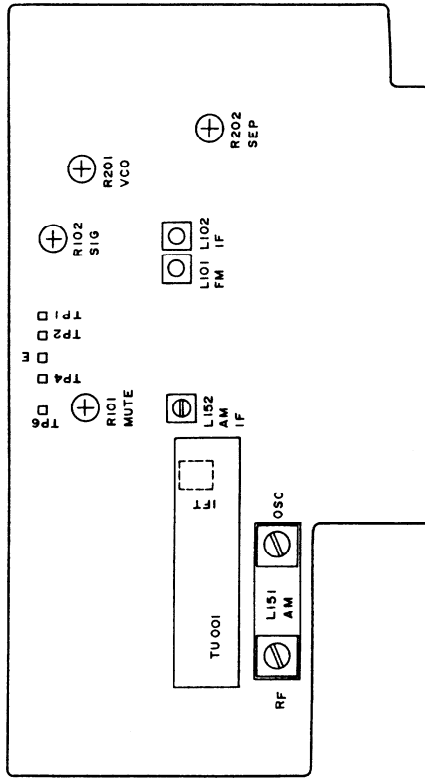

Tuner circuit pc board

Confirmation of tuned voltage

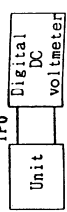

Confirmation of tuned voltage

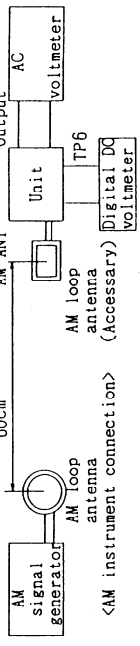

SCHEMATIC DIAGRAM  
CONNECTION DIAGRAM OF MICROPROCESSOR

A B C D E F G

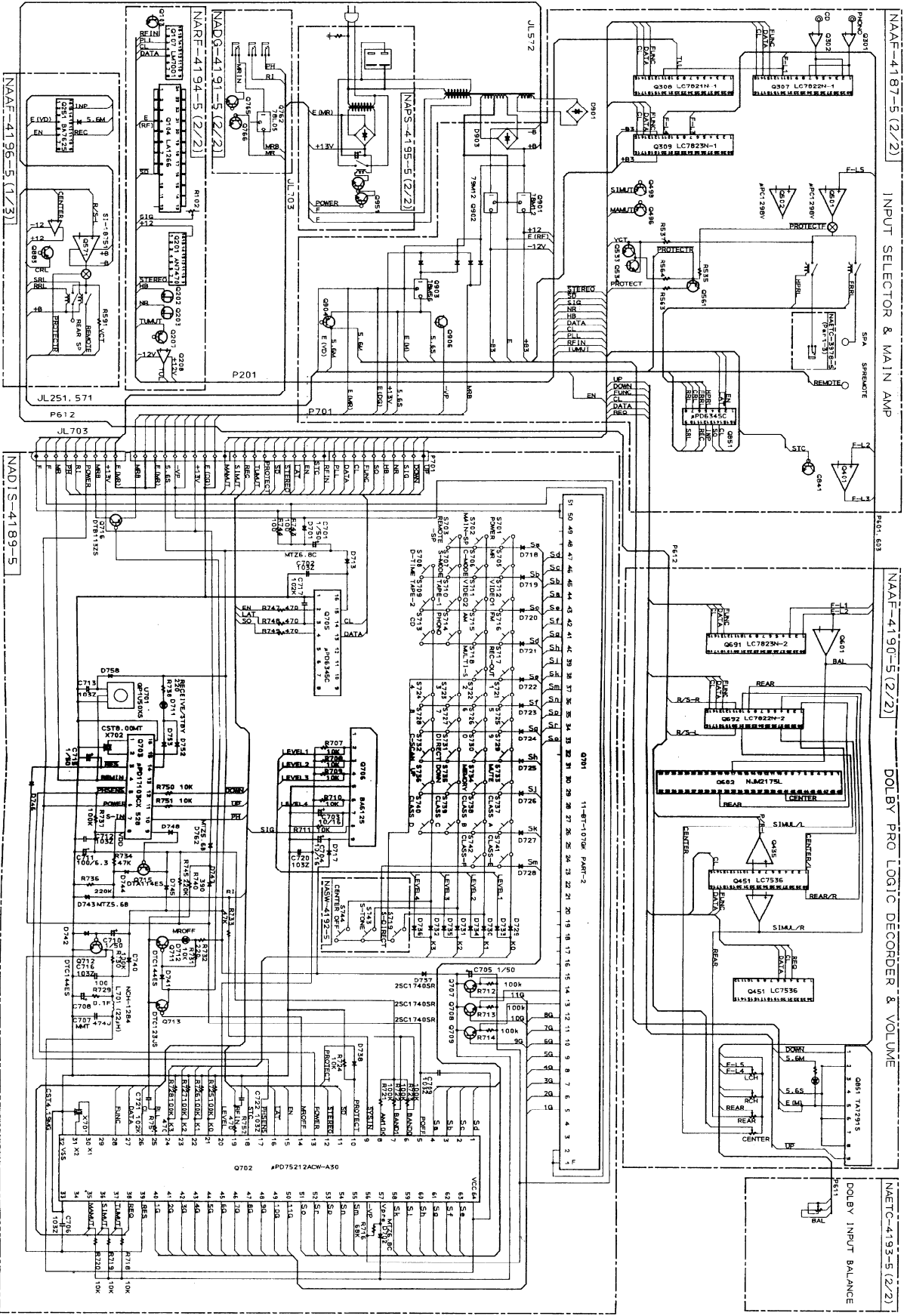



**SCHEMATIC DIAGRAM  
TUNER AND VIDEO SECTION**

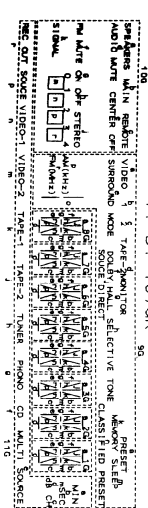
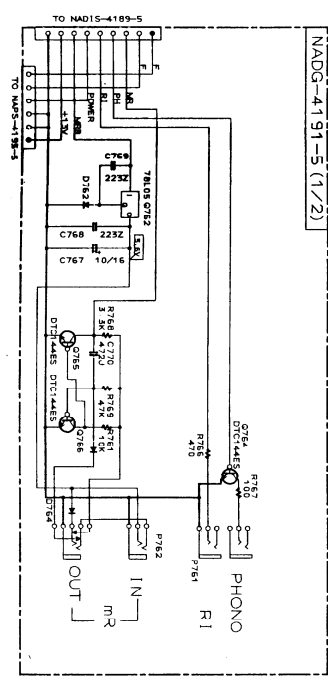
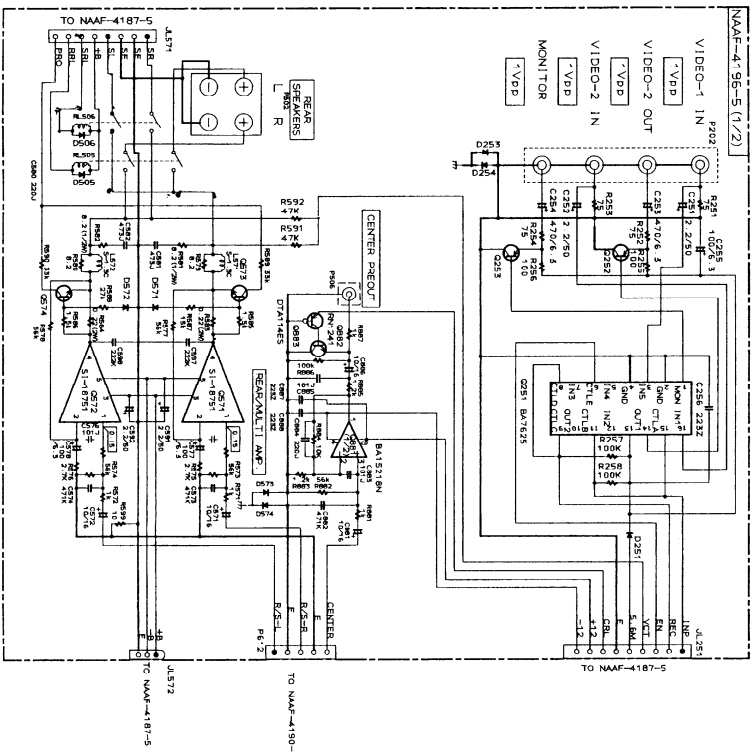
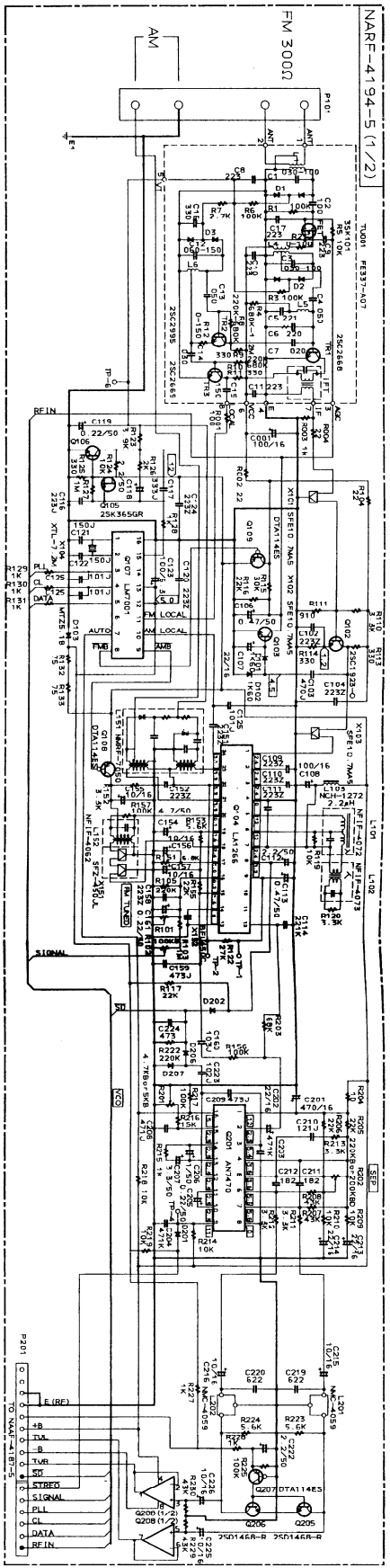



**SCHEMATIC DIAGRAM**  
**SURROUND SECTION**

1 2 3 4 5 6 7

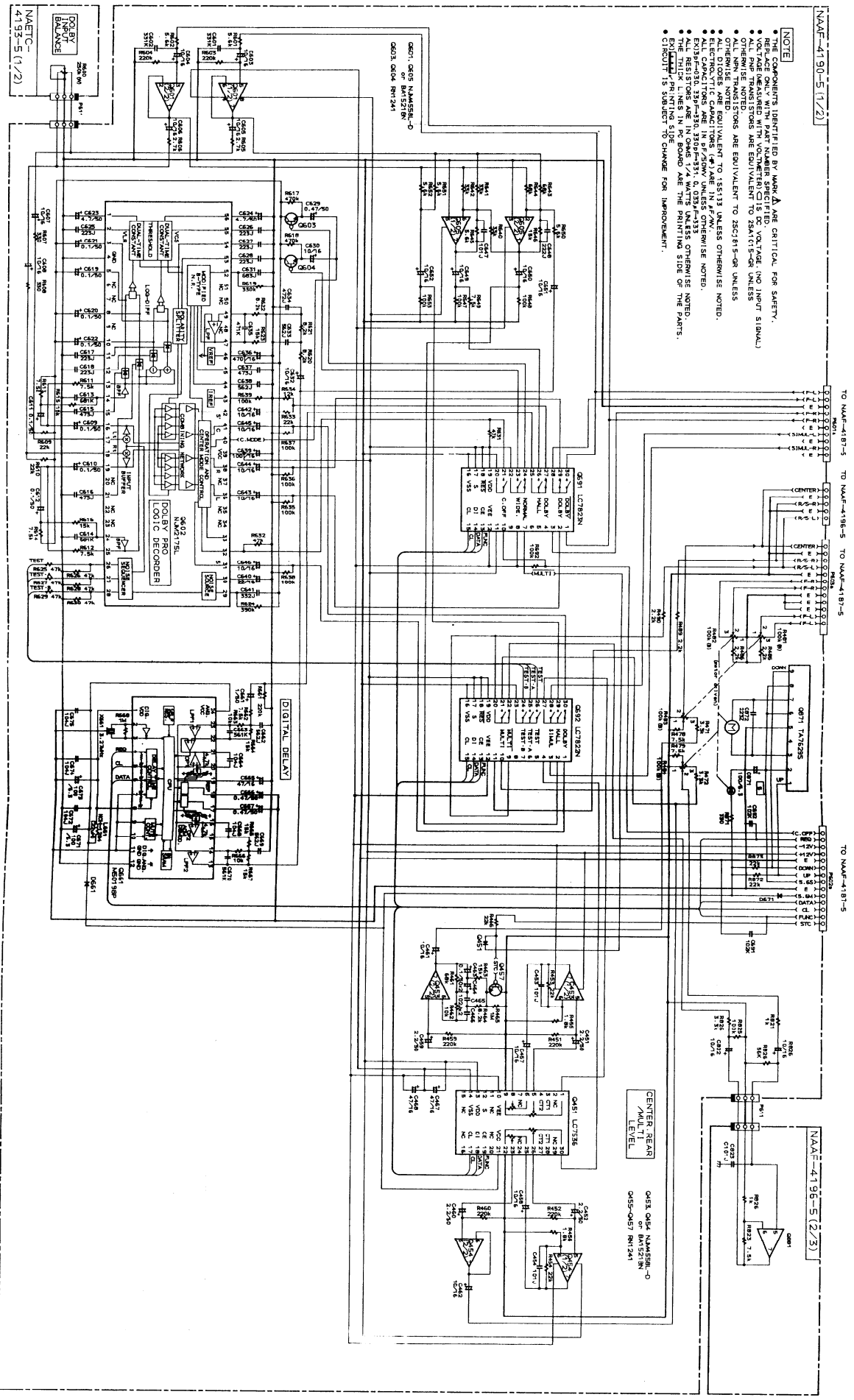

**NOTE**

- THE COMPONENTS IDENTIFIED BY MARK  $\Delta$  ARE CRITICAL FOR SAFETY. REPLACE ONLY WITH PART NUMBER SPECIFIED. NO TOLER. (NO LIMIT SIGNAL).
- ALL PNP TRANSISTORS ARE EQUIVALENT TO 2SA1415-OR UNLESS OTHERWISE NOTED.
- ALL DIODES ARE EQUIVALENT TO 1SS113 UNLESS OTHERWISE NOTED.
- ALL CAPACITORS ARE IN  $\mu$ F/50V UNLESS OTHERWISE NOTED.
- EXCEPT Q851, Q852, Q853, Q854, Q855, Q856, Q857, Q858, Q859, Q860, Q861, Q862, Q863, Q864, Q865, Q866, Q867, Q868, Q869, Q870, Q871, Q872, Q873, Q874, Q875, Q876, Q877, Q878, Q879, Q880, Q881, Q882, Q883, Q884, Q885, Q886, Q887, Q888, Q889, Q890, THE THICK LINES IN THIS BOARD ARE THE PRINTING SIDE OF THE PARTS. EXCEPT PRINTING SIDE FOR IMPROVEMENT.

NAAF-4190-5 (1/2)

NAAF-4196-5 (2/3)



## PRINTED CIRCUIT BOARD PARTS LIST

## CAUTION:

Replacement for transistor of mark ☆, if necessary must be made from the same beta group (HFE) as the original type.

SELECTOR AND POWER AMPLIFIER PC BOARD (NAAF-4187-5)			CIRCUIT NO.	PART NO.	DESCRIPTION
CIRCUIT NO.	PART NO.	DESCRIPTION			
	ICs		D911,D912	223163 or	1SS133 or
Q301	22240191	NJM4565D-D	D991-D994	223205	1SS270A
Q302-Q306	22240247	BA15218N		Coils	
Q307	22240270	LC7822N	L501,L502	231176	S-1.3C
Q308	22240280	LC7821N		Capacitors	
Q309	22240339	LC7823N	C303,C304	354780229	2.2 $\mu$ F,50V,Elect.
Q401,Q402	22240247 or	BA15218N or	C307,C308	354721019	100 $\mu$ F,6.3V,Elect.
	22240293	NJM4558L-D	C309,C310	374726224	6200pF $\pm$ 5%,50V,Plastic
Q501,Q502	22240311	$\mu$ PC1298V	C311,C312	374721824	1800pF $\pm$ 5%,50V,Plastic
Q801	22240247	BA15218N	C313,C314	354761009	10 $\mu$ F,35V,Elect.
Q851	22240211	$\mu$ PD6345C	C315,C316	354744709	47 $\mu$ F,16V,Elect.
Q901	222780122NEC	78M12	C401,C402	354761009	10 $\mu$ F,35V,Elect.
Q902	222790125	79M12	C403,C404	354744709	47 $\mu$ F,16V,Elect.
Q903	222780565JRC	78M56	C405,C406	374721534	0.015 $\mu$ F $\pm$ 5%,50V,Plastic
	Transistors		C409,C410	374721534	0.015 $\mu$ F $\pm$ 5%,50V,Plastic
Q403-Q406	2211945	2SK246-GR	C413-C416	374721044	0.1 $\mu$ F $\pm$ 5%,50V,Plastic
Q491-Q495	2213631 or	RN1241-A or	C417-C420	374721024	1000pF $\pm$ 5%,50V,Plastic
	2213632	RN1241-B	C441,C442	354761009	10 $\mu$ F,35V,Elect.
Q496-Q498	2213510	DTA114ES	C491-C493	354761009	10 $\mu$ F,35V,Elect.
Q503,Q504	2213284	2SC1740S-R	C501,C502	354761009	10 $\mu$ F,35V,Elect.
Q505,Q506	2201653,	☆ 2SC3856-O,	C507,C508	354742219	220 $\mu$ F,16V,Elect.
	2201654,	☆ 2SC3856-Y,	C513,C514	374726834	0.068 $\mu$ F $\pm$ 5%,50V,Plastic
	2201655,	☆ 2SC3856-P,	C515,C516	374724734	0.047 $\mu$ F $\pm$ 5%,50V,Plastic
	2202272 or	☆ 2SC3907-R or	C517-C520	354700109	1 $\mu$ F,160V,Elect.
	2202273	☆ 2SC3907-O	C533,C851	354721019	100 $\mu$ F,6.3V,Elect.
Q507,Q508	2201663,	☆ 2SA1492-O,	C801,C802	354761009	10 $\mu$ F,35V,Elect.
	2201664,	☆ 2SA1492-Y,	C905,C906	3504245	8200 $\mu$ F,50V,Elect.
	2201665,	☆ 2SA1492-O,	C909,C910	3504213	4700 $\mu$ F,35V,Elect.
	2202262 or	☆ 2SA1516-R or	C913,C914	354761009	10 $\mu$ F,35V,Elect.
	2202263	☆ 2SA1516-O	C915	354751029	1000 $\mu$ F,25V,Elect.
Q531-Q534	2211732 or	2SC1845-F or	C917	354761009	10 $\mu$ F,35V,Elect.
	2211733	2SC1845-E	C918	354761019	100 $\mu$ F,35V,Elect.
Q561	2211792 or	2SA992-F or	C919	354781019	100 $\mu$ F,50V,Elect.
	2211793	2SA992-E	C921	354754719	470 $\mu$ F,25V,Elect.
Q861,Q905	221282	DTC144ES		Resistors	
Q862	2213510	DTA114ES	R393	5104225	N11RGLC250KWT22Z,Variable,Balance
Q904	2213830	DTB113ZS	R407,R408	5104230	N14RLC100KWT22Z,Variable,Bass
Q906	2213354	2SA933S-R	R413,R414	5104230	N14RLC100KWT22Z,Variable,Treble
	Diodes		R509,R510	5210261	N06HR 5KBC,Semi-fixed
D401-D404	223163 or	1SS133 or	R515,R516	442520824	8.2 $\Omega$ $\pm$ 5%,1/2W,Metal oxide film
D491-D494	223205	1SS270A	R517,R518	441620824	8.2 $\Omega$ $\pm$ 5%,1W,Metal oxide film
D501,D502	223163 or	1SS133 or	R519,R520	4500031	0.22 $\Omega$ ,5W,Metal plate
D851,D905	223205	1SS270A	R521,R522	442520824	8.2 $\Omega$ $\pm$ 5%,1/2W,Metal oxide film
D561	224450512	MTZ5.1B	R523,R524	441620824	8.2 $\Omega$ $\pm$ 5%,1W,Metal oxide film
D901	22380038	RBV602	R525-R528	442524794	0.47 $\Omega$ $\pm$ 5%,1/2W,Metal oxide film
D903	22380048	RBA402	R529,R530	441623914	390 $\Omega$ $\pm$ 5%,1W,Metal oxide film
D904,D906	22380032,	1SR139-100,	R531,R532	442522224	2.2k $\Omega$ $\pm$ 5%,1/2W,Metal oxide film
D908,D909	22380035 or	GP104003E or	R902	441524794	0.47 $\Omega$ $\pm$ 5%,1/2W,Metal oxide film
	22380046	AM01Z	R903	442523304	33 $\Omega$ $\pm$ 5%,1/2W,Metal oxide film
D907	224451302	MTZ13B	R906	441721804	18 $\Omega$ $\pm$ 5%,2W,Metal oxide film
D910	224452704	MTD27D	R907	441721514	150 $\Omega$ $\pm$ 5%,2W,Metal oxide film

NOTE: THE COMPONENTS IDENTIFIED BY MARK  ARE CRITICAL FOR RISK OF FIRE AND ELECTRIC SHOCK. REPLACE ONLY WITH PART NUMBER SPECIFIED.

CIRCUIT NO.	PART NO.	DESCRIPTION	CIRCUIT NO.	PART NO.	DESCRIPTION
	Resistors			Diodes	
R908	442524704	47 $\Omega$ $\pm$ 5%,1/2W,Metal oxide film	D740-D742	223163 or	1SS133 or
R911	442523314	330 $\Omega$ $\pm$ 5%,1/2W,Metal oxide film	D744-D748	223205	1SS270A
R912	442522204	22 $\Omega$ $\pm$ 5%,1/2W,Metal oxide film	D743,D762	224450562	MTZ5.6B
R913	442524794	0.47 $\Omega$ $\pm$ 5%,1/2W,Metal oxide film	D752-D754	223163 or	1SS133 or
	Relaies		D758	223205	1SS270A
RL501	25065396	NRL-2P1.25A-DC24-067		L.E.Ds	
RL502	25065339	NRL-2P5A-DC24-046	D711,D712	225142	SEL2913K
	Terminals			Coil	
P301-P303	25045300	NPJ-6PDBL159	L701	233411K220	NCH-1387
P501	25060159	NTM-8PDMN085		Ceramic oscillators	
	Plugs		X701	3010163	CST4.19MGW
P201	25055502	NPLG-16P477	X702	3010154 or	CST8.00MT or
P491	25055583	NPLG-7P554		3010190	CST8.00MTW
P511,P512	25055493	NPLG-2P468		Capacitors	
P601	25055499	NPLG-10P474	C701	353780109	1 $\mu$ F,50V,Elect.
P602	25055501	NPLG-14P476	C703,C704	353741009	10 $\mu$ F,16V,Elect.
P603	25055500	NPLG-12P475	C705	353780109	1 $\mu$ F,50V,Elect.
	Socket		C707	375524744	0.47 $\mu$ F $\pm$ 5%,50V,Plastic
JL701a	25050727	NSCT-30P531	C708	3000057	0.1F,5.5V,Super
	Fuses		C710	353780109	1 $\mu$ F,50V,Elect.
F904,F905	252051	 6A ST-6	C711	353721019	100 $\mu$ F,6.3V,Elect.
	Fuseholders		C715	353780109	1 $\mu$ F,50V,Elect.
F904a,F905a	250113	 SN5051		Switches	
	Clamp		S701-S703	25035548	NPS-111-S510
P991	260224	CP-1S	S705-S718	25035548	NPS-111-S510
			S721-S742	25035548	NPS-111-S510
				Socket	
HEADPHONE TERMINAL PC BOARD (NAETC-4188-5)					
CIRCUIT NO.	PART NO.	DESCRIPTION	JL701b	25050728	NSCT-30P532
P504	25045255	YKB21-5009,Terminal,headphone		Plug	
			P702b	25055512	NPLG-5P487
				Holders	
			Q702a	27190842	LED 9
			D711a	27190843	LED 1
				VOLUME CIRCUIT PC BOARD(NAAF-4190-5)	
			CIRCUIT NO.	PART NO.	DESCRIPTION
				ICs	
Q702	22240624	$\mu$ PD75212ACW-A30	Q451	22240468	LC7536
Q703	22240466	$\mu$ PD17103CX-531	Q453,Q454	22240247 or	BA15218N or
Q705	22240211	$\mu$ PD6345C	Q601,Q605	22240293	NJM4558L-D
Q706	22240341	BA6125	Q602	22240458	NJM2175L
	FL tube		Q661	22240370	M50198P
Q701	212115	11-BT-107GK	Q691	22240339	LC7823N
	Transistors		Q692	22240270	LC7822N
Q707-Q709	2213284	2SC1740S-R	Q871	22240239	TA7291S
Q711,Q712	221282	DTC144ES		Transistors	
Q713	2213640	DTC123JS	Q457,Q603	2213631 or	RN1241-A or
Q715	2213510	DTA114ES	Q604	2213632	RN1241-B
Q716	2213830	DTB113ZS		Diodes	
	Opto. receiving module		D451,D661	223163 or	1SS133 or
U701	24130007	GP1U571X	D662,D871	223205	1SS270A
	Diodes				
D701,D702	224450623	MTZ6.2C			
D713,D714	223163 or	1SS133 or			
D717-D738	223205	1SS270A			

**NOTE: THE COMPONENTS IDENTIFIED BY MARK  ARE CRITICAL FOR RISK OF FIRE AND ELECTRIC SHOCK. REPLACE ONLY WITH PART NUMBER SPECIFIED.**

CIRCUIT NO.	PART NO.	DESCRIPTION
	Ceramic oscillator	
X661	3010169	CST3.27MGW002
	Coil	
L661	233411K220	NCH-1387
	Capacitors	
C451,C452	354780229	2.2 $\mu$ F,50V,Elect.
C457,C458	354761009	10 $\mu$ F,35V,Elect.
C459,C460	354780229	2.2 $\mu$ F,50V,Elect.
C461,C462	354761009	10 $\mu$ F,35V,Elect.
C463,C464	354781099	0.1 $\mu$ F,50V,Elect.
C465,C466	374721024	1000pF $\pm$ 5%,50V,Plastic
C467,C468	354744709	47 $\mu$ F,16V,Elect.
C603-C608	354761009	10 $\mu$ F,35V,Elect.
C609-C612	354781099	0.1 $\mu$ F,50V,Elect.
C615,C616	374724734	0.047 $\mu$ F $\pm$ 5%,50V,Plastic
C617,C618	374722234	0.022 $\mu$ F $\pm$ 5%,50V,Plastic
C619-C622	354781099	0.1 $\mu$ F,50V,Elect.
C623,C624	354780479	4.7 $\mu$ F,50V,Elect.
C625-C629	353782299	0.22 $\mu$ F,50V,Elect.
C630,C632	354761009	10 $\mu$ F,35V,Elect.
C631	354786899	0.68 $\mu$ F,50V,Elect.
C635,C648	374722224	2200pF $\pm$ 5%,50V,Plastic
C636	354724719	470 $\mu$ F,6.3V,Elect.
C637	374724734	0.047 $\mu$ F $\pm$ 5%,50V,Plastic
C638	374725624	5600pF $\pm$ 5%,50V,Plastic
C639	354742219	220 $\mu$ F,16V,Elect.
C640	354761009	10 $\mu$ F,35V,Elect.
C641	374723324	3300pF $\pm$ 5%,50V,Plastic
C642-C646	354761009	10 $\mu$ F,35V,Elect.
C649-C652	354761009	10 $\mu$ F,35V,Elect.
C661	354780109	1 $\mu$ F,50V,Elect.
C662,C669	374725624	5600pF $\pm$ 5%,50V,Plastic
C664,C668	374721044	0.1 $\mu$ F $\pm$ 5%,50V,Plastic
C665	354744709	47 $\mu$ F,16V,Elect.
C666,C667	354784799	0.47 $\mu$ F,50V,Elect.
C671,C673	354721019	100 $\mu$ F,6.3V,Elect.
C672,C674	374721044	0.1 $\mu$ F $\pm$ 5%,50V,Plastic
C675	375524744	0.47 $\mu$ F $\pm$ 5%,50V,Plastic
C821,C822	354761009	10 $\mu$ F,35V,Elect.
C871	354721019	100 $\mu$ F,6.3V,Elect.
	Resistor	
R481-R484	5144014A	N16RQL100KBT25F,Variable
	Sockets	
P611	2000556	NSAS-6P512
P612	2009990024	NSAS-10P0048
P601a	25050446	NSCT-10P270
P602a	25050448	NSCT-14P272
P603a	25050447	NSCT-12P271

**RI/MR TERMINAL PC BOARD (NADG-4191-5)**

CIRCUIT NO.	PART NO.	DESCRIPTION
	IC	
Q762	222780053	78L05
	Transistors	
Q764-Q766	221282	DTC144ES
	Diodes	
D761,D762	223163 or	1SS133 or
D764,D765	223205	1SS270A
	Capacitors	
C767	354761009	10 $\mu$ F,35V,Elect.
C770	374724724	4700pF $\pm$ 5%,50V,Plastic
	Terminals	
P761	25045172	HSJ-1003-01-020
P762	25045293	HSJ-1003-01-012
	Socket	
P951a	25050444	NSCT-6P268

**OPERATION SWITCH PC BOARD (NASW-4192-5)**

CIRCUIT NO.	PART NO.	DESCRIPTION
S719,S743	25035548	NPS-111-S510,Switches
S744	25035548	NPS-111-S510,Switch
P702	25050456	NSCT-5P280,Socket







**INPUT BALANCE VOLUME PC BOARD (NAETC-4193-5)**

CIRCUIT NO.	PART NO.	DESCRIPTION
R600	5104258	N11RGLC250KWT15Z,Variable resistor

**TUNER CIRCUIT PC BOARD (NARF-4194-5)**

CIRCUIT NO.	PART NO.	DESCRIPTION
	Front end	
TU001	240088	FE337-A07
	ICs	
Q104	22240039	LA1266
Q107	22240090	LM7001
Q201	22240242	AN7470
Q208	22240247 or	BA15218N or
	22240293	NJM4558L-D
	Transistors	
Q102	2211723	2SC1923-O
Q103,Q106	2213284	2SC1740S-R
Q105	2212445	2SK365-GR
Q108,Q109	2213510	DTA114ES
Q205,Q206	2212794	2SD1468-R
Q207	2213510	DTA114ES
	Diodes	
D101,D102	223132	1K60
D103	224450512	MTZ5.1B
D201,D202	223163 or	1SS133 or
D206,D207	223205	1SS270A
	Crystal oscillator	
X104	3010158 or	XTL-7.2M
	3010141	

NOTE: THE COMPONENTS IDENTIFIED BY MARK  ARE CRITICAL FOR RISK OF FIRE AND ELECTRIC SHOCK. REPLACE ONLY WITH PART NUMBER SPECIFIED.

CIRCUIT NO. PART NO. DESCRIPTION			POWER SUPPLY CIRCUIT PC BOARD (NAPS-4195-5)		
		Coils and transformers			
L101	233401	NFIF-4072			
L102	233402	NFIF-4073			
L103	233411M022	NCH-1375			
L151	232148	NMRF-7050			
L152	232139	NMIF-4062			
L201,L202	233355A	NMC-4059			
		Ceramic filters			
X101,X103	3010071	SFE10.7MA5(RE D)			
X151	3010123	SFZ-450JL			
X152	3010076	BFU-450C			
		Capacitors			
C001,C108	354741019	100 $\mu$ F,16V,Elect.			
C106	354784799	0.47 $\mu$ F,50V,Elect.			
C107	354742209	22 $\mu$ F,16V,Elect.			
C112	354780229	2.2 $\mu$ F,50V,Elect.			
C113	354784799	0.47 $\mu$ F,50V,Elect.			
C116	374722234	0.022 $\mu$ F $\pm$ 5%,50V,Plastic			
C117	374723334	0.033 $\mu$ F $\pm$ 5%,50V,Plastic			
C118	354780229	2.2 $\mu$ F,50V,Elect.			
C119	353782299	0.22 $\mu$ F,50V,Elect.			
C123	354721019	100 $\mu$ F,6.3V,Elect.			
C124	354741019	100 $\mu$ F,16V,Elect.			
C154	354780479	4.7 $\mu$ F,50V,Elect.			
C155-C157	354761009	10 $\mu$ F,35V,Elect.			
C159	374724734	0.047 $\mu$ F $\pm$ 5%,50V,Plastic			
C160	374721034	0.01 $\mu$ F $\pm$ 5%,50V,Plastic			
C161	353782299	0.22 $\mu$ F,50V,Elect.			
C201	354744719	470 $\mu$ F,16V,Elect.			
C202	354742209	22 $\mu$ F,16V,Elect.			
C205	353782299	0.22 $\mu$ F,50V,Elect.			
C206	354780109	1 $\mu$ F,50V,Elect.			
C207	354780339	3.3 $\mu$ F,50V,Elect.			
C208	370134714	470pF $\pm$ 5%,100V,Plastic			
C209	374724734	0.047 $\mu$ F $\pm$ 5%,50V,Plastic			
C211,C212	374721824	1800pF $\pm$ 5%,50V,Plastic			
C213,C214	354742209	22 $\mu$ F,16V,Elect.			
C215,C216	354761009	10 $\mu$ F,35V,Elect.			
C219,C220	374726224	6200pF $\pm$ 5%,50V,Plastic			
C222	354780229	2.2 $\mu$ F,50V,Elect.			
C223	374721024	1000pF $\pm$ 5%,50V,Plastic			
C224	374724734	0.047 $\mu$ F $\pm$ 5%,50V,Plastic			
C225,C226	354761009	10 $\mu$ F,35V,Elect.			
		Resistors			
R101	5210266	N06HR 100KBC,Semi-fixed			
R102,R202	5210267	N06HR 200KBC,Semi-fixed			
R201	5210261	N06HR 5KBC,Semi-fixed			
		Terminal			
P101	25060160	NTM-4PDMN086			
		Socket			
P201	25050449	NSCT-16P273			
		Transistors			
Q951	221282	DTC144ES			
Q952	2213650	DTD113ZS			
		Diodes			
D951-D954	22380032,	1SR139-100,			
	22380035 or	GP104003E or			
	22380046	AM01Z			
D955	223163 or	1SS133 or			
D995,D996	223205	1SS270A			
		Power transformer			
T902	2300670-	 NPT-1111D			
		Capacitors			
C901	3500065A	 DE7150FZ103PAC400V/125V,IS			
C952	354761019	100 $\mu$ F,35V,Elect.			
		Resistors			
R901	431523355	 3.3M $\Omega$ $\pm$ 20%,1/2W,Solid			
R951	442520824	8.2 $\Omega$ $\pm$ 5%,1/2W,Metal oxide film			
		AC outlet			
P902	25050409	 NSCT-4P234			
		Relay			
RL901	25065248	 NRL-1P15A-DC12-29			
		Fuse			
F901	252051	 6A ST-6 <D/W>			
		Fuseholders			
F901a	250113	 SN5051			
		Plug			
P951	25055497	NPLG-6P472			

## VIDEO AND SUB AMPLIFIER PC BOARD (NAAF-4196-5)

CIRCUIT NO.	PART NO.	DESCRIPTION
	ICs	
Q251	22240373	BA7625
Q571,Q572	22240467	SI-18751
Q881	22240247	BA15218N
	Transistors	
Q252,Q253	2213354	2SA933S-R
Q573,Q574	2211732 or 2211733	2SC1845-F or 2SC1845-E
Q883	2213510	DTA114ES
Q884	2213631 or 2213632	RN1241-A or RN1241-B
	Diodes	
D251	223163 or	1SS133 or
D253,D254	223205	1SS270A
D505,D506	223163 or	1SS133 or
D571-D574	223205	1SS270A
	Coils	
L571,L572	231176	S-1.3C
	Capacitors	
C251,C252	354780229	2.2 $\mu$ F,50V,Elect.
C253,C254	354724719	470 $\mu$ F,6.3V,Elect.
C255	354721019	100 $\mu$ F,6.3V,Elect.
C571,C572	354761009	10 $\mu$ F,35V,Elect.
C577,C578	354741019	100 $\mu$ F,16V,Elect.
C581,C582	374724734	0.047 $\mu$ F $\pm$ 5%,50V,Plastic
C591,C592	354780229	2.2 $\mu$ F,50V,Elect.
C881,C886	354761009	10 $\mu$ F,35V,Elect.
	Resistors	
R581,R582	442520824	8.2 $\Omega$ $\pm$ 5%,1/2W,Metal oxide film
R583,R584	4000059	0.22 $\Omega$ ,2W,Metal plate
	Relaies	
RL505,RL506	25065339	NRL-2P5A-DC24-046
	Terminal	
P251	25045339	NPJ-4PDYE190
P502	25060161	NTM-4PDML087
P506	25045302	NPJ-1PDBL161
	Plug	
P612a	25055135	NPLG-5P119
	Sockets	
JL251	25050273	NSCT-9P101
JL571	25050272	NSCT-8P100
JL572,JL605	25050267	NSCT-3P95



# PACKING VIEW

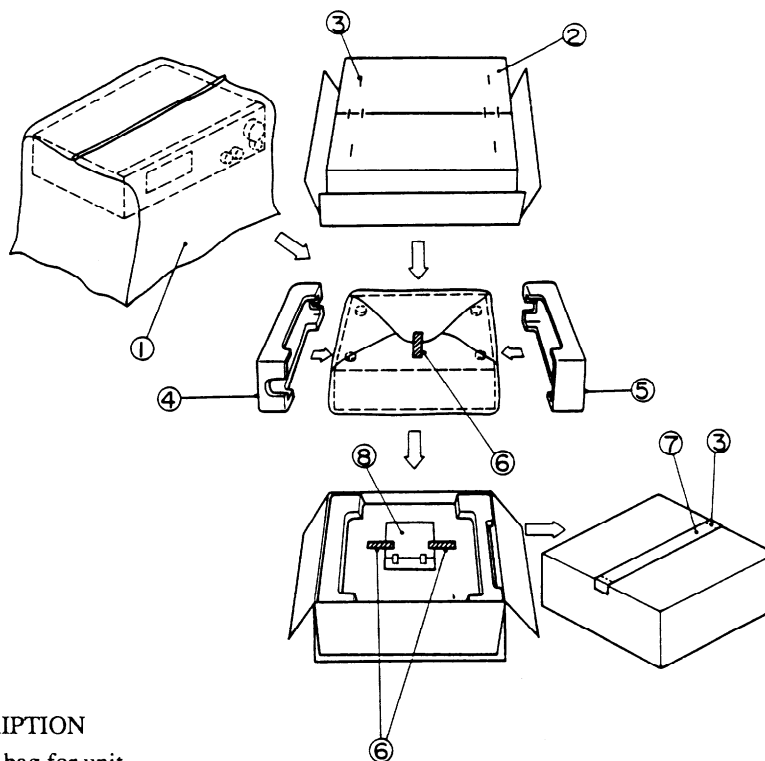

REF.NO.	PART NO.	DESCRIPTION
1	29100034A	Styrene bag for unit
2	29052441Y	Master carton box
3	282301	Sealing hook
4	29091449B	Pad R
5	29091448B	Pad L
6	261504	Adhesive tape
7	29110071	Damplon tape
8	Accessory bag ass'y	
	29341755AY	Instruction manual
	29341756Y	Instruction manual <C>
	292111	FM antenna
	232140	NMA-3057,AM loop antenna
	2010200	Connection cord
	3010054	UM-3,Two batteries
	24140237Y	RC-237S,Remote control transmitter
	29365019A	Warranty card <N>
	29358002J	Service station list <N>
	29100097	Styrene bag for accessory

NOTE: <N>:U.S.A. model  
<C>:Canadian model

## ONKYO CORPORATION

International Division: Onarimon Yusen Bldg., 23-5, Nishi-Shimbashi 3-chome, Minato-ku,  
TOKYO 105, JAPAN Tel: 03-432-6987 Fax: 03-436-6979

**ONKYO U.S.A CORPORATION**  
200 Williams Drive, Ramsey, N.J. 07446, U.S.A.  
Tel: 201-825-7950 Fax: 201-825-8150