

ONKYO SERVICE MANUAL

QUARTZ SYNTHESIZED TUNER AMPLIFIER MODEL TX-SV515PRO II

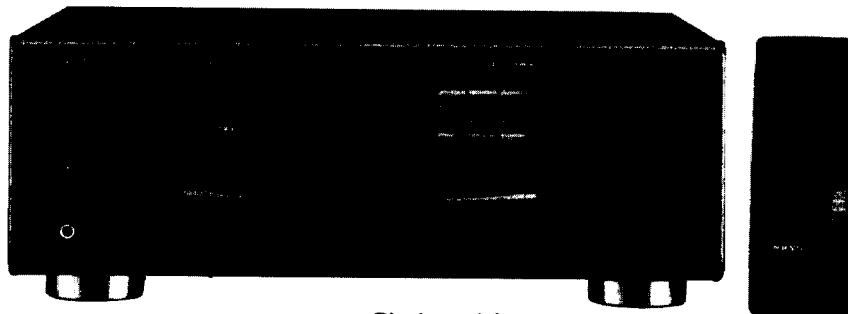

Black model

BMD, BMDN, BMDC	120V AC, 60Hz
BMP	230V AC, 50Hz
BMW	120/220V AC, 50/60Hz
BMQA	240V AC, 50Hz

SAFETY-RELATED COMPONENT WARNING!!
COMPONENTS IDENTIFIED BY MARK Δ ON THE SCHEMATIC DIAGRAM AND IN THE PARTS LIST ARE CRITICAL FOR RISK OF FIRE AND ELECTRIC SHOCK. REPLACE THESE COMPONENTS WITH ONKYO PARTS WHOSE PART NUMBERS APPEAR AS SHOWN IN THIS MANUAL.
MAKE LEAKAGE-CURRENT OR RESISTANCE MEASUREMENTS TO DETERMINE THAT EXPOSED PARTS ARE ACCEPTABLY INSULATED FROM THE SUPPLY CIRCUIT BEFORE RETURNING THE APPLIANCE TO THE CUSTOMER.

TABLE OF CONTENTS

- Specifications.....2
- Service procedures.....3
- Exploded view.....4
- Parts list.....5
- Microprocessor descriptions.....6
- IC block diagrams and descriptions.....9
- Block diagram.....19
 - Amplifier section.....19
 - Tuner section.....20
- Adjustment procedures.....22
- Printed circuit board views from bottom side.....25
- Schematic diagram.....31
 - Connection diagram of microprocessor.....31
 - Tuner section.....33
 - Power supply and video section.....35
 - Audio section.....37
 - Surround section.....39
- Printed circuit board-parts list.....41
- Packing view.....46



SPECIFICATIONS

AMPLIFIER SECTION

Power Output:	Stereo mode Front L/R channels 80 watts per channel min. RMS. at 8 ohms, both channels driven, from 20 Hz to 20,000 Hz, with no more than 0.08% total harmonic distortion. Continuous Power output: 2 x 115 watts 4 ohms 1 kHz DIN 2 x 90 watts 8 ohms 1 kHz DIN
	Surround mode and Multi source mode Front L/R and center channels 55 watts per channel min. RMS. at 8 ohms 1,000 Hz, with no more than 0.08% total harmonic distortion. Rear or Remote channels 20 watts per channel min. RMS. at 8 ohms 1,000 Hz, with no more than 0.8% total harmonic distortion.
Total Harmonic Distortion:	0.08% at rated power (FRONT)
IM Distortion:	0.08% at rated power (FRONT)
Damping Factor:	60 at 8 ohms (FRONT)
Sensitivity and Impedance:	Phono: 2.5 mV/50 kohms CD/Tape Play: 150 mV/50 kohms Tape Rec: 150 mV/2.2 kohms
Phono Overload:	120 mV RMS. at 1,000 Hz, 0.5% THD.
Frequency Response:	20 to 30,000 Hz, +/-1 dB
RIAA Deviation:	20 to 20,000 Hz, +/-0.8 dB
Tone Control:	BASS: +/-10 dB at 100 Hz TREBLE: +/-10 dB at 10,000 Hz
Signal to Noise Ratio:	PHONO: 80 dB (IHF A, 5 mV input) CD/TAPE: 100 dB (IHF A)
Muting:	- ∞ dB

VIDEO SECTION

Signal sensitivity and impedance
VDP/VCR input, output: 1 Vp-p, 75 ohms

TUNER SECTION

FM: (other models)

Tuning Range:	87.5 — 108.0 MHz (50 kHz steps)
Usable Sensitivity:	Mono: 11.2 dBf, 1.0 μV, 75 ohms 0.9 μV (S/N 26 dB, 40 kHz Devi.) 75 ohms DIN Stereo: 18.0 dBf, 2.2 μV, 75 ohms 23 μV (S/N 46 dB, 40 kHz Devi.) 75 ohms DIN
50dB Quieting Sensitivity:	Mono: 18.0 dBf, 2.2 μV, 75 ohms Stereo: 37.2 dBf, 20 μV, 75 ohms
Capture Ratio:	1.5 dB
Image Rejection Ratio:	85 dB
IF Rejection Ratio:	90 dB
Signal-to-Noise Ratio:	Mono: 73 dB Stereo: 67 dB
Selectivity:	50 dB DIN (±300 kHz, 40 kHz Devi.)
AM Suppression Ratio:	50 dB
Harmonic Distortion:	Mono: 0.15 % Stereo: 0.25 %
Frequency Response:	30 — 15,000 Hz ±1.5 dB
Stereo Separation:	45 dB at 1 kHz

AM:

Tuning Range:	European models 522 — 1611 kHz (9 kHz steps) USA and Canadian models 530 — 1710 kHz (10 kHz steps) Saudi Arabia and worldwide models 531 — 1602 kHz (9 kHz steps)
Usable Sensitivity:	30 μV
Image Rejection Ratio:	40 dB
IF Rejection Ratio:	40 dB
Signal-to-Noise Ratio:	40 dB
Total Harmonic Distortion:	0.7 %

TUNER SECTION

FM: (120V model)

Tuning Range:	87.5 — 108.0 MHz (50 kHz steps)
Usable Sensitivity:	Mono: 11.2 dBf, 2.0 μV Stereo: 17.2 dBf, 4.0 μV Mono: 17.2 dBf, 4.0 μV Stereo: 37.2 dBf, 40 μV
50dB Quieting Sensitivity:	1.5 dB
Capture Ratio:	40 dB
Image Rejection Ratio:	90 dB
IF Rejection Ratio:	Mono: 73 dB Stereo: 67 dB
Signal-to-Noise Ratio:	55 dB
Alternate Channel Attenuation:	50 dB
AM Suppression Ratio:	Mono: 0.15% Stereo: 0.25%
Total Harmonic Distortion:	30 — 15,000 Hz +/-1.5 dB
Frequency Response:	45 dB at 1 kHz/30 dB at 100 — 10,000 Hz
Stereo Separation:	17.2 dBf, 4.0 μV
Muting Level:	

GENERAL

Dimensions (W x H x D):	455 x 170 x 388 mm 17-15/16" x 6-11/16" x 15-5/16"
Weight:	13.5 kg (29.8 lbs)

SERVICE PROCEDURES

1. Replacing the fuses

For continued protection against fire hazard, replace only with same type and same rating fuse.

Circuit no.	Part no.	Description
F901	252166Y	△6.3A-UL/T-237,Primary fuse <D/W>
F902	252076	△3.15A-SE-EAK,Primary fuse <P/W/Q>
F903	252075	△2.5A-SE-EAK,AC outlet fuse <P>
F911,F912	252166Y	△6.3A-UL/T237,Secondary fuse <D>
	252079	△6.3A-SE-EAK,Secondary fuse <P/W/Q>

NOTE: <D> :Only 120V model
<P> :Only 230V model
<W> :Only Worldwide model
<Q> :Only 240V model

2. Change of FM/AM band step.

With the exception of the Worldwide model, a BAND STEP selector switch is not provided.

(AM)

BAND STEP	R724	D711
10kHz→9kHz	Addition	Addition
9kHz→10kHz	Eliminated	Eliminated

In R724 Carbon resistor 1 kΩ

(Part No.417341024) is used.

In D711 Diode 1SS270A

(Part No.223205) is used.

—Worldwide model—

Worldwide models are equipped with a step band selector switch. This switch is located on the back panel. This switch is set to 9kHz (AM) at the factory, but may have to be reset to 10kHz depending on the area where the unit is used.

AM step

Europe: 9kHz

U.S.A: 10kHz

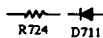
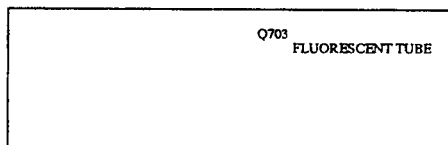

DISPLAY CIRCUIT PC BOARD

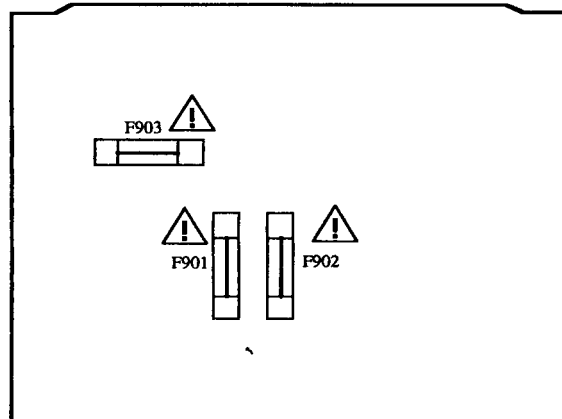

POWER SUPPLY CIRCUIT PC BOARD



MAIN CIRCUIT PC BOARD

3. Memory preservation

This unit does not require memory preservation batteries. A built-in memory power back-up system preserves contents of the memory during power failures and even when the unit is unplugged. The unit must be plugged in and the power switch turned on and off once in order to charge the back-up system. Note that since this is not a permanent memory the power switch must be turned on and off a few times each month to keep the back-up system operative. The period of time during which memory contents are preserved after power has last been turned off varies depending on climate and placement of the unit. On the average, memory contents are protected over a period of 3 to 4 weeks (a minimum of 2 weeks) after the last time power has been turned off. This period is shorter when the unit is exposed to very high humidity or used in an area with an extremely humid climate.

4. Safety-check out

(Only U.S.A. model)

After correcting the original service problem perform the following safety check before releasing the set to the customer.

Connect the insulating-resistance tester between the plug of power supply cord and terminal GND on the back panel. Specifications: 3.3 Mohm ±10% at 500V.

5. Change of voltage

Worldwide models are equipped with a voltage selector to conform with local power supplies. This switch is located on the back panel. Be sure to set this switch to match the voltage of the power supply in your area before turning the power switch on.

This switch is set to 220V at the factory. Voltage is changed by sliding the groove in the switch with the screwdriver to the right or left. Confirm that the switch has been moved all the way to the right or left before turning the power switch on.

EXPLODED VIEW

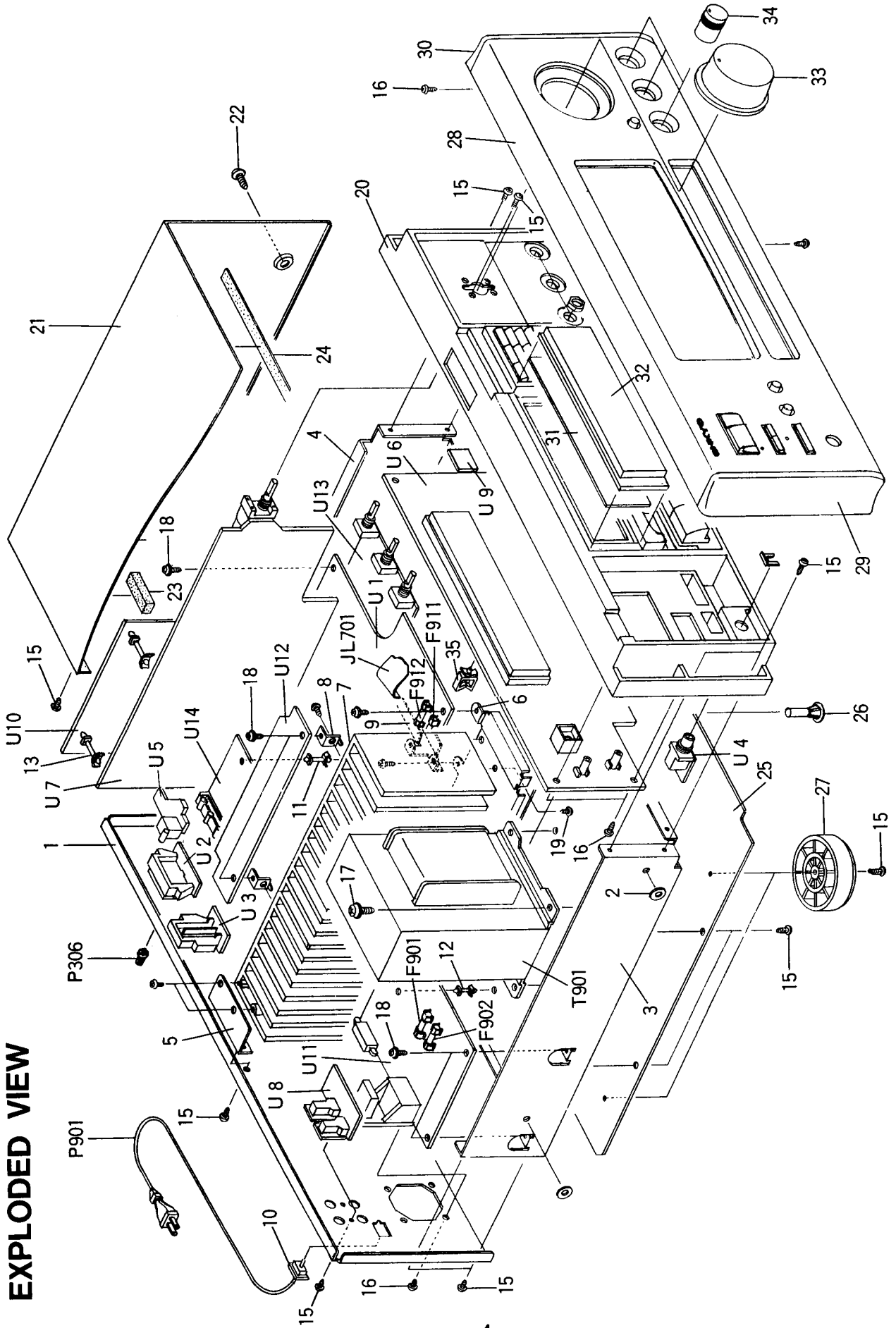

PARTS LIST

REF.NO.	PART NO.	DESCRIPTION	REF.NO.	PART NO.	DESCRIPTION	REF.NO.	PART NO.	DESCRIPTION
1	27121921Y	Rear panel <D>	JL701	2041322010 or	NCFC1-322010 or	U3	1A542594-5Y	NAETC-4694-5,Speaker terminal pc board ass'y <D>
	27121922Y	Rear panel <P>		2047322012	NCFC7-322012,Flexible flat cable			
	27121923Y	Rear panel <W>	P306	25060044	Terminal ground		1A542594-5A Y	NAETC-4694-5A,Speaker terminal pc board ass'y <P/W/Q>
	27121924Y	Rear panel <Q>	P901	253163Y or	AS-UC-6 #18,	U4	1A542595-5Y	NAETC-4695-5,Headphone terminal pc board ass'y
2	27220212	Spacer <P/W/Q>		253174Y	Power supply cord <D/PX>			
3	27130717AY	Bracket,power transformer		253175Y or	AS-CEB-2,	U5	1A542596-5Y	NAETC-4696-5,Output terminal pc board ass'y
4	27115255Y	Side bracket		253164Y	Power supply cord <P/W>			
5	27141607AY	Retainer H	P902,P903	25050904	AS-SAA,Power supply cord <Q>	U6	1A542597-5Y	NADIS-4697-5,Display circuit pc board ass'y <D>
6	27130718AY	Bracket H	Q505,Q506	2201653,	NSCT-2697,AC outlet <Q>			
7	27160323Y	Radiator		2201654,	2SC3886-O,		1A542597-5A Y	NADIS-4697-5A,Display circuit pc board ass'y <D>
8	27141530A	Retainer HS-2		2201655,	2SC3856-Y,			
9	27141532	Retainer PD-1		2201655,	2SC3856-P,		1A542597-5B Y	NADIS-4697-5B,Display circuit pc board ass'y <W>
10	27300750	Cond.bushing		2202272 or	2SC3907-R or	U7	1A542598-5Y	NAAF-4698-5,Surround circuit pc board ass'y <D/W/Q>
11	27190369	KGLS-22S,Holder	Q507,Q508	2201663,	2SC3907-O,Power transistors			
12	27190480	KGLS-8S,Holder		2201664,	2SA1492-O,		1A542598-5A Y	NAAF-4698-5A,Surround circuit pc board ass'y <P>
13	27190062	KGLS-12S,Holder		2201665,	2SA1492-Y,			
14	801433	3SMS8W, SW+14R(BC),Sems screw		2202262 or	2SA1516-R or	U8	1A542599-5Y	NAETC-4699-5,R/M/R terminal pc board ass'y <P>
15	834430088	3TTS+8B(BC),Self-tapping screw		2202263	2SA1516-O,Power transistors			
16	833430080	3TTP+8P(BC),Self-tapping screw	Q543	2202253,	2SC4467-O,		1A542599-5B Y	NAETC-4699-5B,R/M/R terminal pc board ass'y <D/P/Q>
17	830440089	4TTC+8C(BC),Self-tapping screw		2202254,	2SC4467-Y,			
18	831130088	3TTW+8B,Self-tapping screw		2202254,	2SC4467-P,			
19	834430108	3TTS+10R(BC),Self-tapping screw		2202502 or	2SC3181N-R or	U9	1A542500-5Y	NASW-4700-5,STC switch pc board ass'y pc board ass'y <W>
20	27110754FY	Front bracket ass'y	Q544	2202503	2SC3181N-O,Power transistor	U10	1A542501-5Y	NARF-4701-5,Tuner circuit pc board ass'y <D>
21	28184535Y	Top cover		2202243,	2SA1694-O,			
22	838440089	4TTB+8C(BC),Self-tapping screw		2202244,	2SA1694-Y,		1A542501-5A Y	NARF-4701-5A,Tuner circuit pc board ass'y <P/Q>
23	28141132	6.1 X 60 X 10,Cushion		2202246,	2SA1694-P,			
24	28140680	0.5 1 X 390 X 10,Cushion		2202492 or	2SA1264N-R or		1A542501-5B Y	NARF-4701-5B,Tuner circuit pc board ass'y <W>
25	27170300AY	Bottom panel		2202493	2SA1264N-O,Power transistor	U11	1A542502-5Y	NARF-4702-5,Power supply circuit pc board ass'y <D>
26	27190926	KGLS-18RE,Holder	Q575,Q576	2202063,	2SC4511-O,			
27	27175251AY	Leg		2202064 or	2SC4511-Y or		1A542502-5A Y	NARF-4702-5A,Power supply circuit pc board ass'y <D>
28	1A542121Y	Front panel ass'y		2202066	2SC4511-P,Power transistors			
28A	27267822Y	Guide VOL	Q577,Q578	2202053,	2SA1725-O,		1A542502-5B Y	NARF-4702-5B,Power supply circuit pc board ass'y <W>
28B	27267824Y	Guide POW		2202054 or	2SA1725-Y or			
29	28125251AY	End cap L		2202056	2SA1725-P,Power transistors		1A542502-5C Y	NARF-4702-5C,Power supply circuit pc board ass'y <Q>
30	28125252AY *	End cap R	T901	2300891 Y	NPT-1168P,Power transformer <D>			
31	28191661	Clear plate		2300892 Y	NPT-1168P,Power transformer <P>		1A542502-5D Y	NAPS-4702-5D,Power supply circuit pc board ass'y <PX>
32	28133299Y	Back plate		2300893 Y	NPT-1168DQ,Power transformer <W>			
33	28324775A	Knob VOLUME	U1	2300894 Y	NPT-1168Q,Power transformer <Q>	U12	1A542503-5Y	NAAF-4703-5,Rear amplifier pc board ass'y <D>
34	28324376A	Knob TONE		1A542592-5Y	NAAR-4692-5,Main circuit pc board ass'y <D>			
35	880009	Plastic rivet <P>		1A542592-5A Y	NAAR-4692-5A,Main circuit pc board ass'y <P/W/Q>	U13	1A542503-5A Y	NAAF-4703-5A,Rear amplifier pc board ass'y <P/W/Q>
F901	252166Y	6.3A -JL/T-237,Primary fuse <D/W>		1A542593-5Y	NAETC-4693-5,Center speaker terminal pc board ass'y <D>	U14	1A542505-5Y	NAETC-4705-5,Video circuit pc board ass'y
F902	252076	3.15A -SE-EAK,Primary fuse <P/W/Q>	U2					
F903	252075	2.5A -SE-EAK,AC outlet fuse <P>						
F911,F912	252166Y	6.3A -JL/T-237,Secondary fuse <D>						
	252079	6.3A -SE-EAK,Secondary fuse <P/W/Q>						

NOTE: THE COMPONENTS IDENTIFIED BY MARK Δ ARE CRITICAL FOR RISK OF FIRE AND ELECTRICAL SHOCK. REPLACE ONLY WITH PART NUMBER SPECIFIED.

NOTE: <D>-120V model only
<P>-230V model only
<W>-Worldwide model only

MICROPROCESSOR DESCRIPTIONS

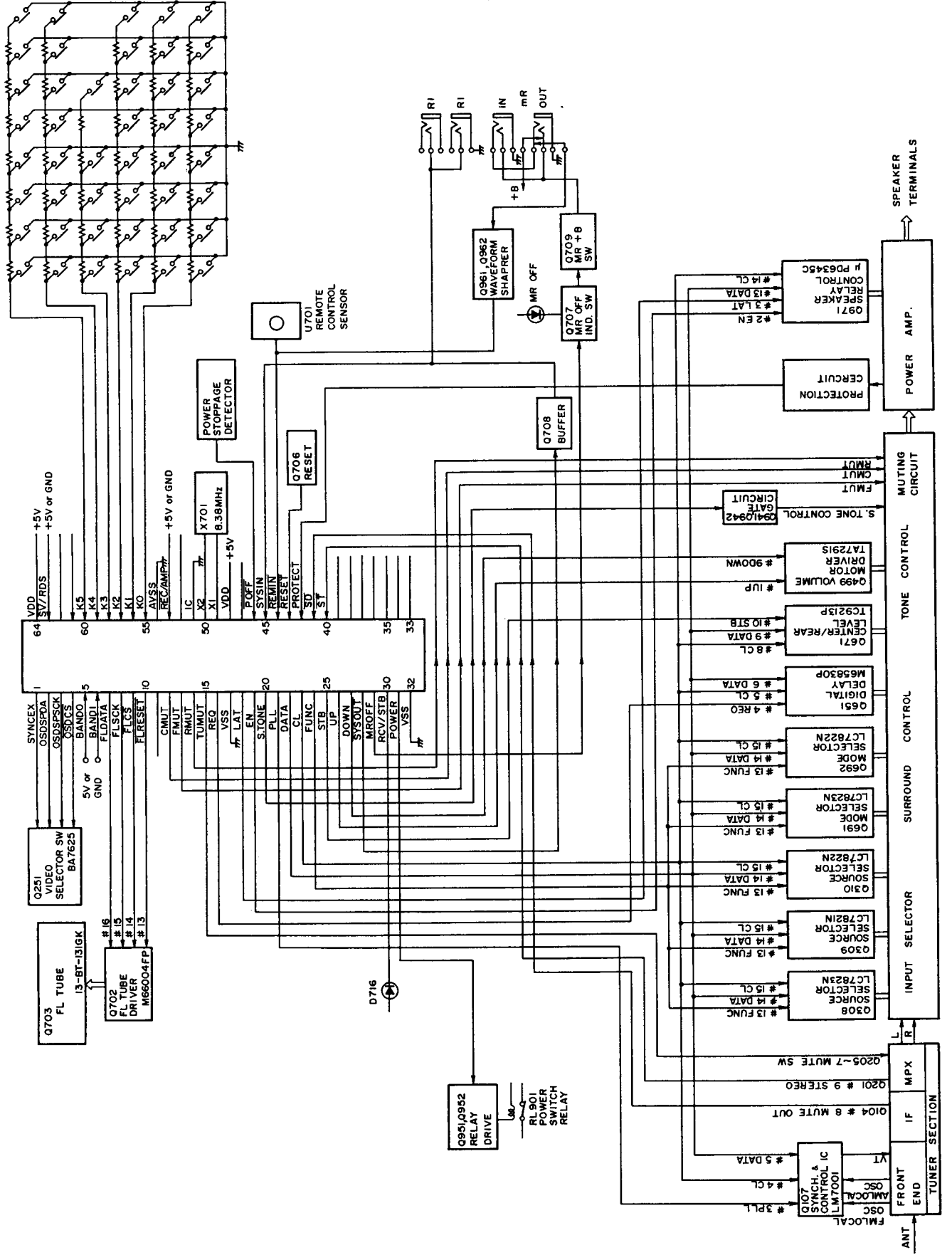

Terminal Description

Pin No.	Function	I/O	Description													
1	SYNCEX	O	Video signal control A output terminal.													
2	OSDSPDA	O	Video signal control D output terminal.													
3	OSDSPSCK	O	Video signal control B output terminal.													
4	OSDCS	O	Video signal control C output terminal.													
5	BAND0	I	Initializing input terminal for FM/AM band region.													
6	BAND1	I														
7	FLSDATA	O	Connect to the terminal SDATA of Fluorescent tube driver M66004FP. (Q702)													
8	FLSCK	O	Connect to the terminal SCK of Fluorescent tube driver M66004FP.													
9	FLCS	O	Connect to the terminal CS of Fluorescent tube driver M66004FP.													
10	FLRST	O	Connect to the terminal RESET of Fluorescent tube driver M66004FP.													
11	PLAYER	O	Player control output terminal. Not used.													
12	CENTMUT	O	Muting output terminal for the center amplifier.													
13	FRONTMUT	O	Muting output terminal for the front amplifier.													
14	REARMUT	O	Muting output terminal for the rear amplifier.													
15	TU MUT	O	Muting output terminal for the tuner.													
16	REQ	O	Connect to the terminal REQ of Digital delay M65830P.(Q651)													
17	VSS	-	Ground terminal													
18	LAT	O	Connect to the terminal LAT of Output extended IC μ PD6345C.(Q971)													
19	EN	O	Connect to the terminal EN of Output extended IC μ PD6345C.													
20	S.TONE	O	Selective tone control output terminal.													
21	PLL	O	Connect to the terminal CE of PLL IC.(Q107)													
22	DATA	O	Connect to the terminal DI of Analog switches LC7821N,LC7822N, and LC7823N, the terminal DATA of PLL IC LM7001, the terminal DATA of Electro volume TC9213P, the terminal DATA of Digital delay M65830P, and the terminal SIN of Output extended IC μ PD6345C.													
23	CL	O	Connect to the terminal CL of Analog switches LC7821N,LC7822N, and LC7823N, the terminal CL of PLL IC LM7001, the terminal CK of Electro volume TC9213P, the terminal SCK of Digital delay M65830P, and the terminal SCK of Output extended IC μ PD6345C.													
24	FUNC	O	Connect to the terminal CE of Analog switches LC7821N,LC7822N, and LC7823N. (Q309,Q310,Q692,Q308 and Q691)													
25	STB	O	Connect to the terminal STB of Electro volume TC9213P. (Q671)													
26	VOLUP	O	Volume UP/DOWN control output. (Q499)													
27	VOLDOWN	O														
				<table border="1"> <thead> <tr> <th>Operation</th> <th>#27</th> <th>#26</th> </tr> </thead> <tbody> <tr> <td>Stop</td> <td>H</td> <td>H</td> </tr> <tr> <td>Volume up</td> <td>L</td> <td>H</td> </tr> <tr> <td>Volume down</td> <td>H</td> <td>L</td> </tr> </tbody> </table>	Operation	#27	#26	Stop	H	H	Volume up	L	H	Volume down	H	L
Operation	#27	#26														
Stop	H	H														
Volume up	L	H														
Volume down	H	L														
28	SYSOUT	O	System code output terminal.													

VIDEO SIGNAL CONTROL OUTPUT

#1	#3	SOURCE
L	L	VIDEO-3
H	L	VIDEO-2
L	H	
H	H	VIDEO-1

#4	#2	SOURCE
L	L	VIDEO-3
H	L	VIDEO-2
L	H	
H	H	VIDEO-1
Same as #1	Same as #3	Other position
Same as #1	Same as #3	Multi mode

Pin No.	Function	I/O	Description
29	MR	O	MULTI ROOM indicator control output.
30	STBY/RCV	O	STAND-BY/RECEIVED indicator control output.
31	POWER	O	Power switch relay control output.
32	VSS		Ground terminal.
33	————	O	Not used.
34	————	O	Not used.
35	————	O	Not used.
36	————	O	Not used.
37	————	O	Not used.
38	————	O	Not used.
39	————	I	Not used.
40	STEREO	I	Stereo detection input terminal.
41	SD	I	Broadcast detection input terminal.
42	PROTECT	I	Protection circuit operation detection input terminal.
43	RESET	I	System reset input terminal.
44	REMIN	I	Remote control signal input terminal.
45	SYSIN	I	System code input terminal.
46	POFF	I	Detection input terminal for the stoppage of electric current.
47	————	I	Not used.
48	VDD		Power supply terminal.(+5V)
49	X2		Ceramic resonator connection terminal for the main system clock .
50	X1		Connect the ceramic resonator 8.38 MHz.
51	IC		Connect to the ground terminal.
52	XT2		Not used.
53	XT1		
54	AVSS		Ground terminal of A/D converter.
55	K0	I	Operation key connection terminals.
56	K1	I	
57	K2	I	
58	K3	I	
59	K4	I	
60	K5	I	
61	————		Not used.
62	MODE	I	Initializing input terminal for Receiver or Amplifier.
63	AVDD		Analogue power supply terminal of A/D converter. (+5V)
64	AVREF		Reference voltage input terminal of A/D converter.

Initializing Input

#7,#6

BAND1	BAND0	Regin	Band	Frequency Range	Channel Space
0	0	U.S.A.	FM	87.50~108.00MHz	50kHz
			AM	530~1710kHz	10kHz
0	1	Europe	FM	87.50~108.00MHz	50kHz
			AM	530~1710kHz	9kHz
1	0	Worldwide	FM	87.50~108.00MHz	50kHz
			AM	530~1710kHz	9kHz
1	1	Japan	FM	87.50~108.00MHz	100kHz
			AM	530~1710kHz	9kHz

#62

MODE	OPERATION
0	Receiver
1	Amplifier

BLOCK DIAGRAM TUNER SECTION (120V model)

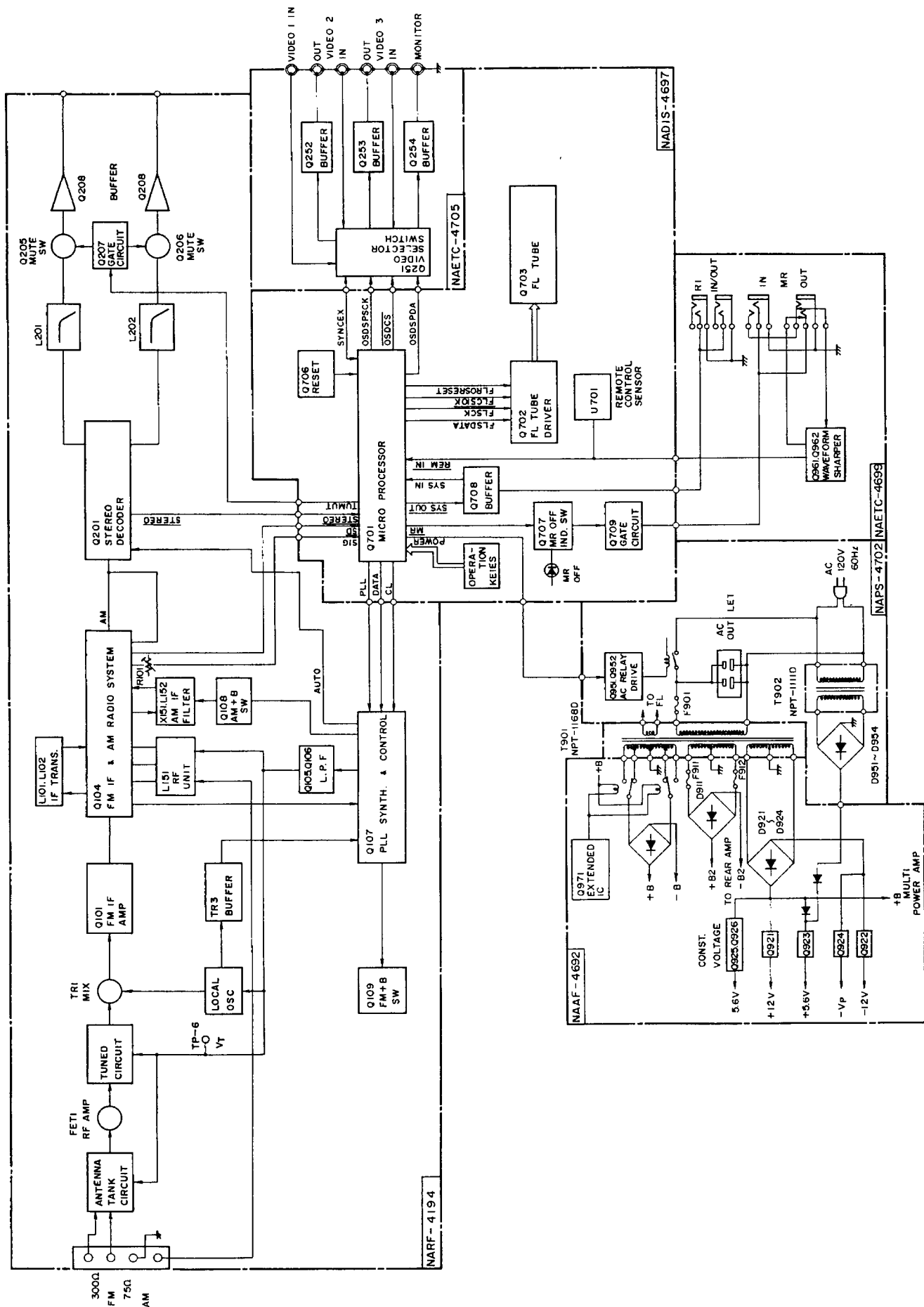

(Other models)

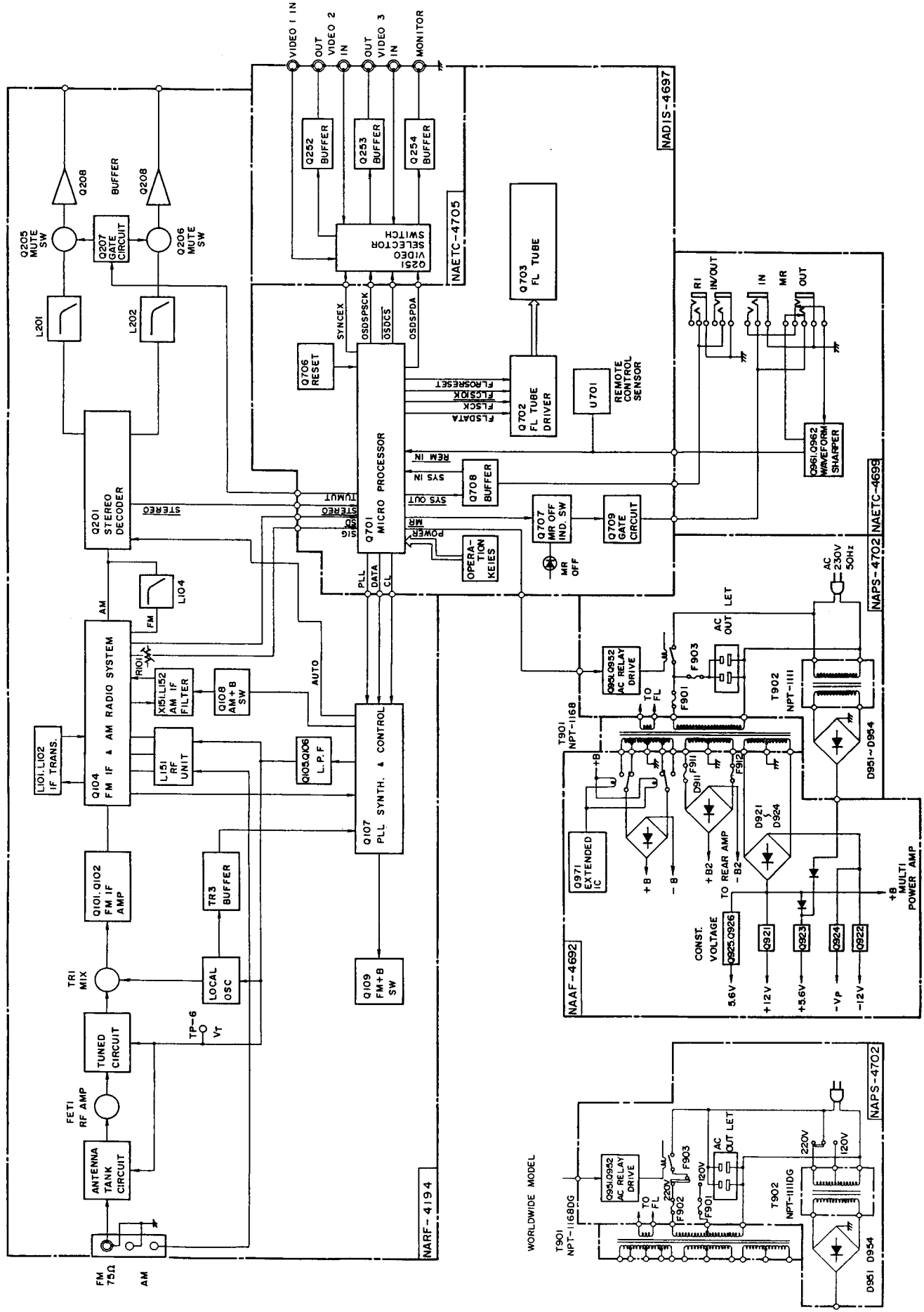

ADJUSTMENT PROCEDURES

• Preparation

1. Input

FM mono : 1 kHz, 75kHz devi., 60dB/μV

FM stereo : 1 kHz, 75kHz devi., 60dB/μV

Pilot signal 19kHz 7.5kHz devi.

AM : 400Hz 30% mod.

2. Outputs

Connect the non-inductive type resistors of 8ohms to the main speaker, remote speaker, and rear speaker terminals unless otherwise noted.

3. Initializing of unit

1. Press and hold down th CD button, then press the POWER button.

2. "Test-" is displayed on the display for approximately 5 seconds.

3. While "Test-" is displayed, unplug the TX-SV515PROII's power cord from its AC outlet, then "Test-" will disappear.

4. Preset memory and parameters stored in memory, such as surround are initialized and will return to the factory settings.

4. Standard Knob Position

TAPE MONITOR 2OFF
 VOLUME.....Maximum
 BASS/TREBLE/BALANCE.....Center
 MUTING.....OFF
 REC SELECTOR.....SOURCE
 INPUT SELECTOR.....CD
 SPEAKERSON
 S.T.C.....OFF

SURROUND MODE.....OFF
 CENTER MODE.....WIDE
 DELAY TIME.....20mS
 MULTI/REAR LEVELCenter
 MR OFF.....ON

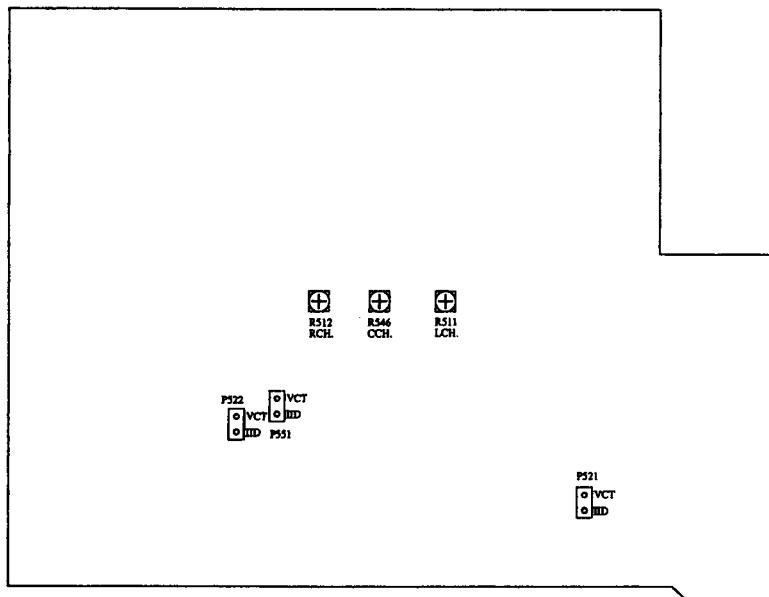

MAIN CIRCUIT PC BOARD

Amplifier section

Idling Current Adjustment

Connect the DC voltmeter to the terminals P521, P522, and P551 (VCT and IID) on the main circuit pc board.

Adjust the trim resistors R511, R512 and R546 so that the indicator of voltmeter becomes $5 \pm 0.5mV$.

NOTE:Adjust after switching on for 5 minutes.

FM section

Item	Step	Connection of instrument	FM SG output	Stereo modulator output	Tuning frequency	Output indicator	Adjustment point	Adjust for	Remarks
FM IF/RF	1	Fig.1	99.1MHz 1kHz 75kHz devi. 65dBf(60dB)	————	99.1MHz	DC voltmeter	L101	0±20mV	FM MUTE/MODE switch:ON/STEREO Repeat the steps 1 and 3 until no further adjustment is necessary.
	AC voltmeter					IFT on the front end	Maximum		
	Distortion analyzer					L102	Minimum		
VCO		Fig.2	99.1MHz 1kHz 75kHz devi. 65dBf(60dB)	————	99.1MHz	Frequency counter	R201	19kHz±10Hz	
Stereo Distortion		Fig.3	99.1MHz Ext. mod.65dBf(60dB)	Channel L or R 1kHz	99.1MHz	Distortion analyzer	IFT on the front end	Minimum	Don't turn more than ±180°
Stereo Separation	1	Fig.3	99.1MHz Ext. mod. 65dBf(60dB)	Channel L 1kHz	99.1MHz	Channel R AC voltmeter	R202	Minimum	Maximum and same separation
	2			Channel R 1kHz		Channel L AC voltmeter		Minimum	
Muting Level		Fig.3	99.1MHz 17.2dBf(12dB) <19.2dBf(14dB)>	————	99.1MHz	Oscilloscope	R101	Signal output	

NOTE:< >:230V and Worldwide models

AM section

120V model

Step	AM SG output	Tuning Frequency	Output Indicator	Adjustment point	Adjust for
1		530kHz	Digital DC voltmeter	OSC coil on RF block L151	1.4±0.2V
2	600kHz 400Hz 30% mod. 60dB/m	600kHz	AC voltmeter	RF coil on RF block L151	Maximum
3	990kHz 400Hz 30% mod. 60dB/m	990kHz	AC voltmeter	L152	Maximum

Reference Specification

FM tuned voltage:87.9MHz-107.9MHz
More than1.3V-Less than 10V
AM tuned voltage:530kHz-1710kHz
1.4±0.2V-Less than 9.0V

230V and Wolrdwide models

Step	AM SG output	Tuning Frequency	Output Indicator	Adjustment point	Adjust for
1		522kHz or 531kHz	Digital DC voltmeter	OSC coil on RF block L151	1.3±0.2V
2	603kHz 400Hz 30% mod. 60dB/m	603kHz	AC voltmeter	RF coil on RF block L151	Maximum
3	999kHz 400Hz 30% mod. 60dB/m	999kHz	AC voltmeter	L152	Maximum

Reference Specification

FM tuned voltage:87.5MHz-108MHz
More than1.3V-Less than 10V
AM tuned voltage:522kHz-1611kHz
1.3±0.2V-Less than 9.0V
(230V model)
AM tuned voltage:531kHz-1602kHz
1.3±0.2V-Less than 9.0V
(Worldwide model)

A B C D E F G

SCHEMATIC DIAGRAM (PART-1) CONNECTION DIAGRAM OF MICROPROCESSOR

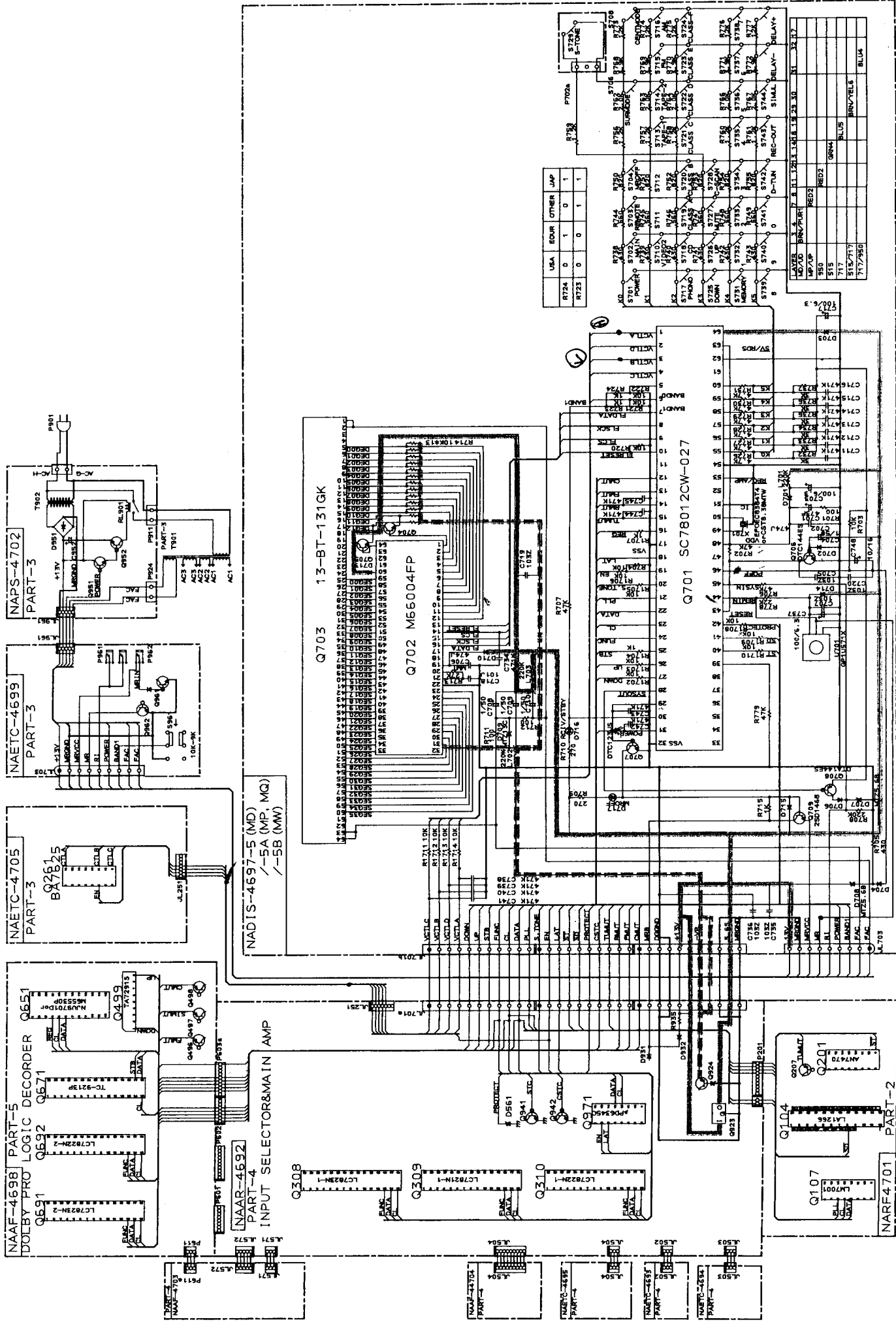

	USA	SOA	OTHER	JAP
R724	0	1	0	1
R723	0	0	0	1

MP/UP	REO2	GRN4	BLU5	BRN/VEL5	BLU6
930					
715					
717					
515/717					
717/950					

A B C D E F G

**SCHEMATIC DIAGRAM (PART-2)
TUNER SECTION**

NARF-4701-5 (MD)
/-5A (MP, MQ)
/-5B (MW)

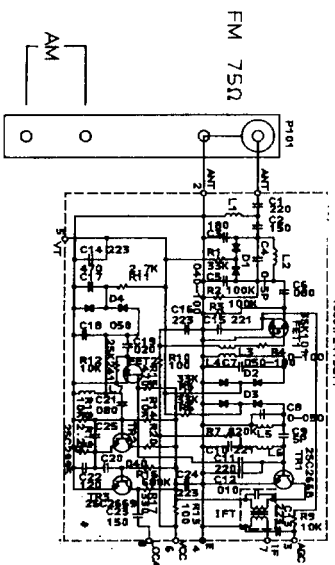
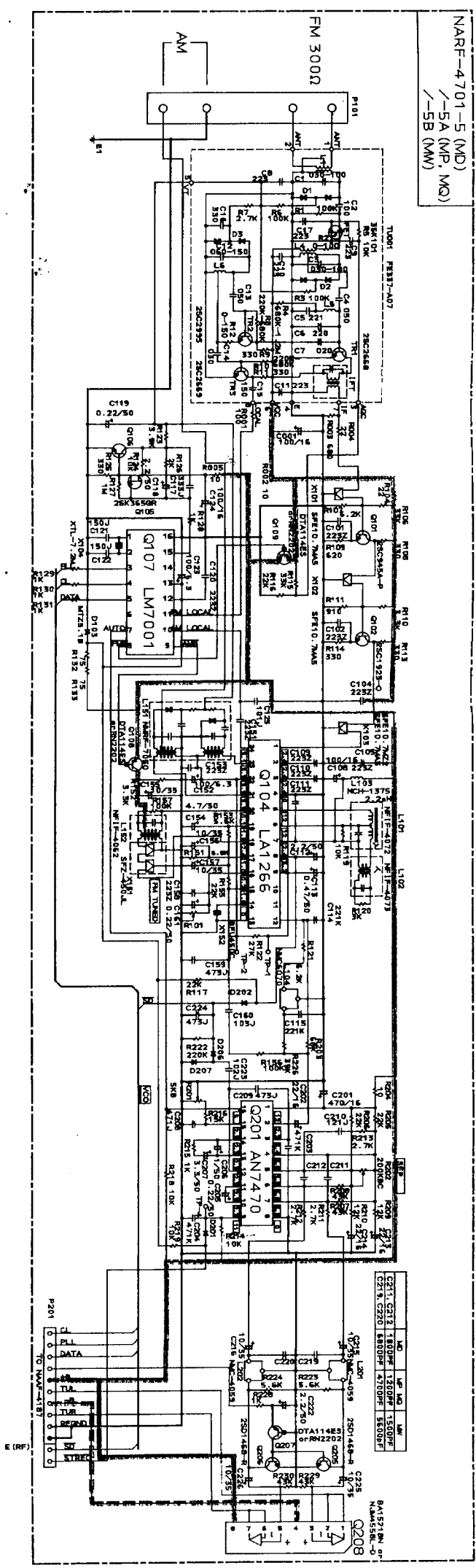

Q101	Q102	Q103	Q104	Q105	Q106	Q107	Q108	Q109	Q110	Q111	Q112	Q113	Q114	Q115	Q116	Q117	Q118	Q119	Q120
MD	MP/MW/MQ	No parts	O	No parts	MD	MP/MW/MQ	No parts	MD	MP/MW/MQ	No parts	MD	MP/MW/MQ	No parts	MD	MP/MW/MQ	No parts	MD	MP/MW/MQ	No parts
Q101	Q102	Q103	Q104	Q105	Q106	Q107	Q108	Q109	Q110	Q111	Q112	Q113	Q114	Q115	Q116	Q117	Q118	Q119	Q120
Q101	Q102	Q103	Q104	Q105	Q106	Q107	Q108	Q109	Q110	Q111	Q112	Q113	Q114	Q115	Q116	Q117	Q118	Q119	Q120
Q101	Q102	Q103	Q104	Q105	Q106	Q107	Q108	Q109	Q110	Q111	Q112	Q113	Q114	Q115	Q116	Q117	Q118	Q119	Q120

5

4

3

2

1

A B C D E F G

**SCHEMATIC DIAGRAM (PART-3)
POWER SUPPLY AND VIDEO SECTION**

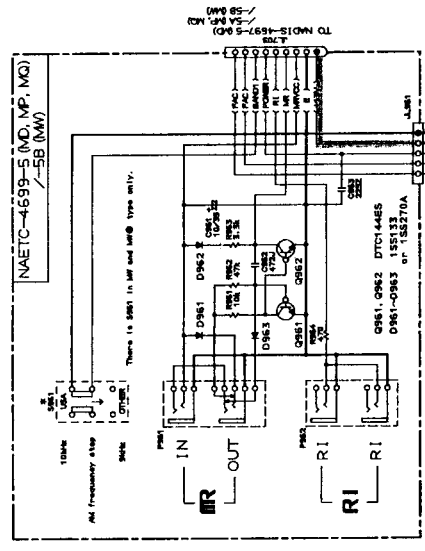
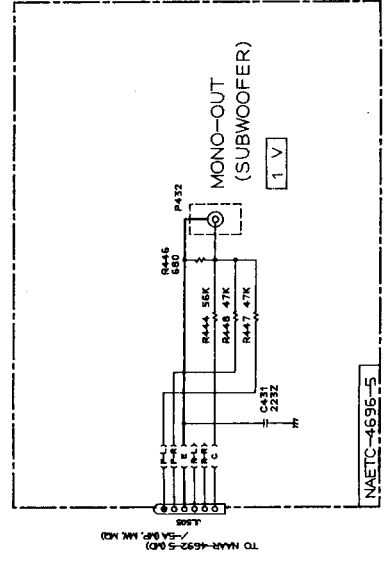

- MD type : 120V/60Hz Area
- MD type : U.S.A.
- MD type : Canada
- MP type : 230V/50Hz Area
- MP type : Europe (except for Germany)
- MP type : Germany (MODEL No. TX-SV9041)
- MW type : 120V or 220V Switchable
- MW type : Worldwide
- MW type : For PX
- MQ type : 240V/50Hz Area
- MQ type : Australia

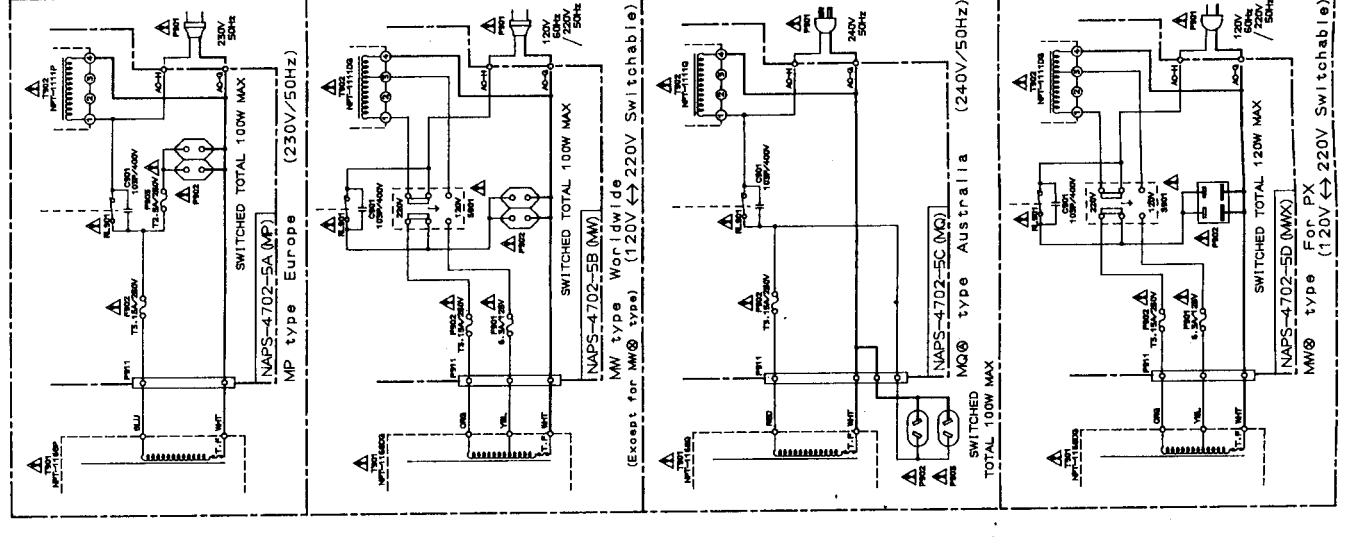
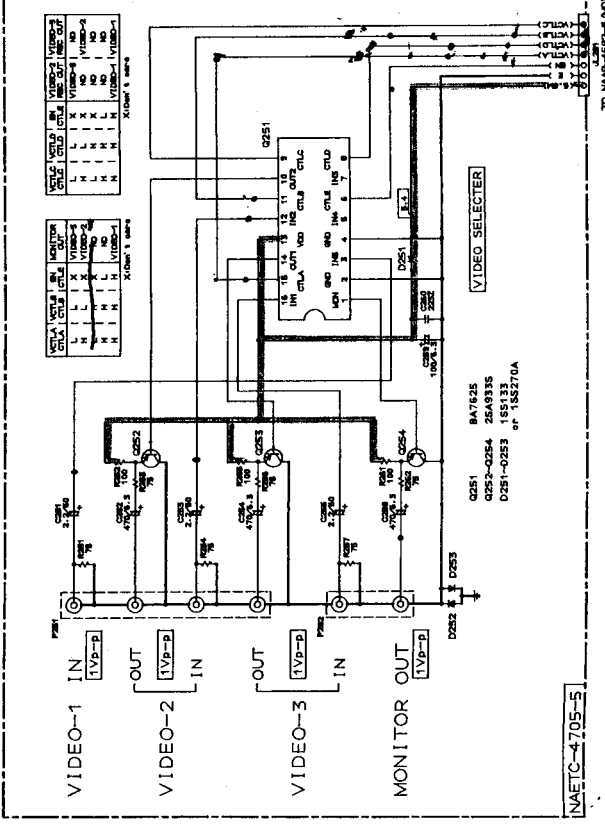

TO NAR-4692-5 (MD, MP, MQ)

TO NAR-4692-5 (MD) U.S.A. & Canada (120V/60Hz)

TO NAR-4692-5 (MW, MQ)

A B C D E F G
SCHEMATIC DIAGRAM (PART-4)
AUDIO SECTION

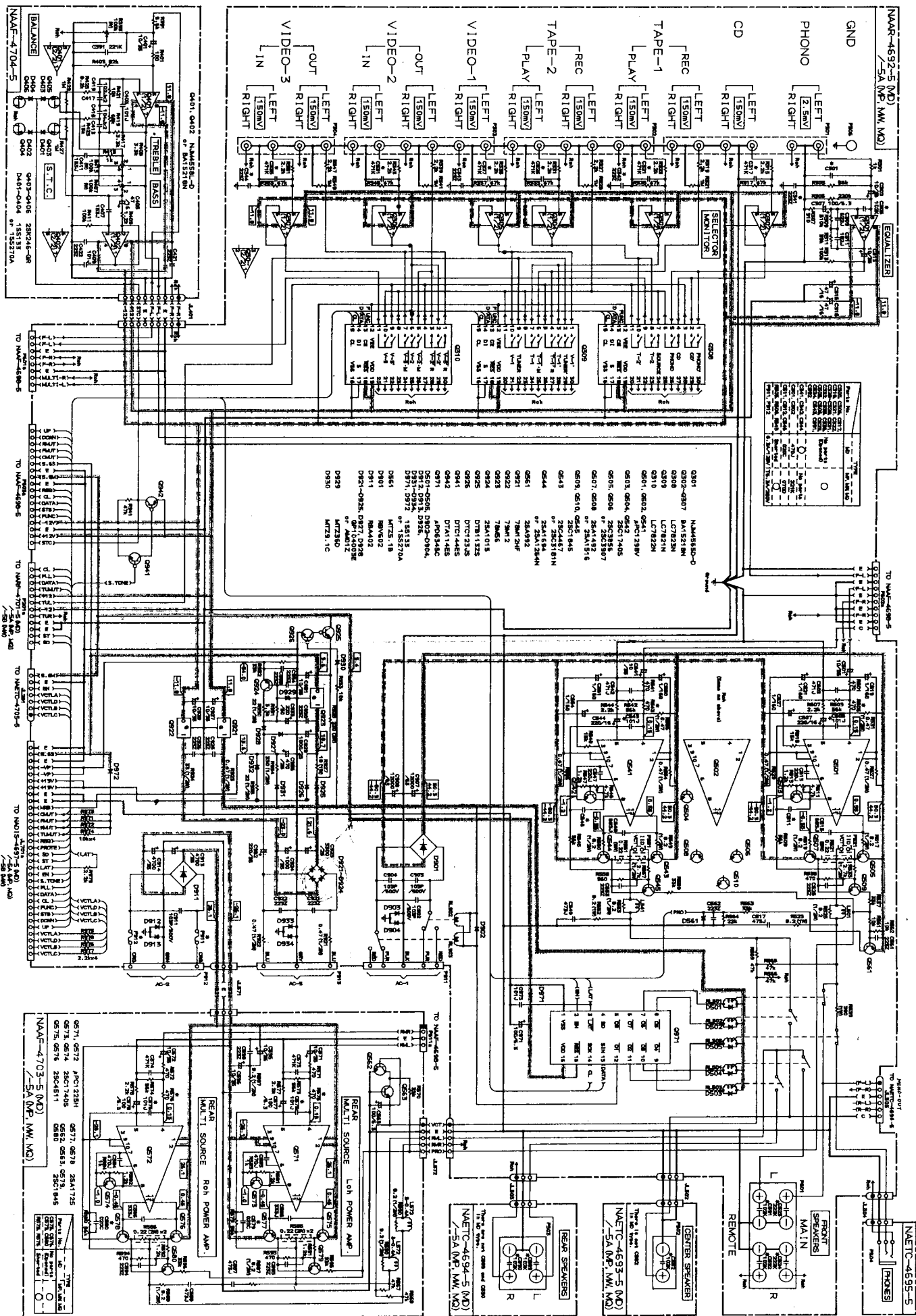

PRINTED CIRCUIT BOARD PARTS LIST

MAIN CIRCUIT PC BOARD (NAAR-4692-5/5A)

CIRCUIT NO.	PART NO.	DESCRIPTION	CIRCUIT NO.	PART NO.	DESCRIPTION
	ICs			Diodes	
Q301	22240191	NJM4565D-D	D912,D913	223205 or	1SS270A or
Q302-Q307	22240247	BA15218N	D926	223163	1SS133
Q308	22240339	LC7823N	D921-D925	22380046 or	AM01Z or
Q309	22240280	LC7821N	D927,D928	22380035	GP104003E
Q310	22240270	LC7822N	D929	224453604	MTZ36D
Q501,Q502	22240311	μ PC1298V	D930	224450913	MTZ9.1C
Q541	22240311	μ PC1298V	D931-D934	223205 or	1SS270A or
Q921	222780125NEC	78M12HF	D971,D972	223163	1SS133
Q922	222790125	79M12		Coils	
Q923	222780565JRC	78M56	L501,L502	231209S	S-0.4A
Q971	22240211	μ PD6345C	L541	231209S	S-0.4A
	Transistors			Capacitors	
Q503,Q504	2213284	2SC1740S-R	C303,C304	354761009	10 μ F,35V,Elect.
Q542	2213284	2SC1740S-R	C307,C308	354721019	100 μ F,6.3V,Elect.
Q505,Q506	2201653,	☆ 2SC3856-O,	C309,C310	374726224	6200pF \pm 5%,50V,Plastic
	2201654,	☆ 2SC3856-Y,	C311,C312	374721824	1800pF \pm 5%,50V,Plastic
	2201655,	☆ 2SC3856-P,	C313,C314	354761009	10 μ F,35V,Elect.
	2202272 or	☆ 2SC3907-R or	C315,C316	354744709	47 μ F,16V,Elect.
	2202273	☆ 2SC3907-O	C501,C502	354761009	10 μ F,35V,Elect.
Q507,Q508	2201663,	☆ 2SA1492-O,	C503,C504	374724714	470pF \pm 5%,50V,Plastic
	2201664,	☆ 2SA1492-Y,	C507,C508	354742219	220 μ F,16V,Elect.
	2201665,	☆ 2SA1492-P,	C515,C516	374726834	0.068 μ F \pm 5%,50V,Plastic
	2202262 or	☆ 2SA1516-R or	C517,C518	374724734	0.047 μ F \pm 5%,50V,Plastic
	2202263	☆ 2SA1516-O	C519-C522	354700109	1 μ F,160V,Elect.
Q509,Q510	2211732 or	2SC1845-F or	C527,C528	354700109	1 μ F,160V,Elect.
	2211733	2SC1845-E	C541	354761009	10 μ F,35V,Elect.
Q543	2202253,	☆ 2SC4467-O,	C542	374724714	470pF \pm 5%,50V,Plastic
	2202254,	☆ 2SC4467-Y,	C544	354742219	220 μ F,16V,Elect.
	2202256,	☆ 2SC4467-P,	C548	374726834	0.068 μ F \pm 5%,50V,Plastic
	2202502 or	☆ 2SC3181N-R or	C549	374724734	0.047 μ F \pm 5%,50V,Plastic
	2202503	☆ 2SC3181N-O	C550,C551	354700109	1 μ F,160V,Elect.
Q544	2202243,	☆ 2SA1694-O,	C554	354700109	1 μ F,160V,Elect.
	2202244,	☆ 2SA1694-Y,	C907,C908	3504258	12000 μ F,63V,Elect.
	2202246,	☆ 2SA1694-P,	C913,C914	3504213S	4700 μ F,35V,Elect.
	2202492 or	☆ 2SA1264N-R or	C923	354753329	3300 μ F,25V,Elect.
	2202493	☆ 2SA1264N-O	C924	354761029	1000 μ F,35V,Elect.
Q561	2211792 or	2SA992-F or	C927,C928	354761009	10 μ F,35V,Elect.
	2211793	2SA992-E	C929	354751029	1000 μ F,25V,Elect.
Q924	2211455	2SA1015-GR	C931	354761009	10 μ F,35V,Elect.
Q925	2213830	DTB113ZS	C932	354762219	220 μ F,35V,Elect.
Q926	2213640	DTC123JS	C933	354782219	220 μ F,50V,Elect.
Q941	221282	DTC144ES	C936	354754719	470 μ F,25V,Elect.
Q942	2213510	DTA114ES	C971	354721019	100 μ F,6.3V,Elect.
	Diodes			Resistors	
D501-D505	223205 or	1SS270A or	R511,R512	5210261	N06HR 5KBC,Trim
D902-D904	223163	1SS133	R517-R520	452530824	8.2 ohm,1/2W,Metal
D561	224450512	MTZ5.1B	R521,R522	4000132	0.22 ohm \times 2,5.5W + 5.5W,Metal plate
D901	22380038	RBV602	R523,R524	451630824	8.2 ohm,1W,Metal
D911	22380048	RBA402	R525,R526	452530824	8.2 ohm,1/2W,Metal
			R527-R532	452534794	0.47 ohm,1/2W,Metal

TX-SV515PRO II

CAUTION: Replacement for transistor of mark ☆, if necessary, must be made from the same beta group (H FE) as the original type.

NOTE: THE COMPONENTS IDENTIFIED BY MARK Δ ARE CRITICAL FOR RISK OF FIRE AND ELECTRIC SHOCK. REPLACE ONLY WITH PART NUMBER SPECIFIED.

CIRCUIT NO.	PART NO.	DESCRIPTION
	Resistors	
R533,R534	442522724	2.7 kohm,1/2W,Metal oxide
R539,R540	441623914	390 ohm,1W,Metal oxide
R546	5210261	N06HR 5KBC,Trim
R549,R550	452530824	8.2 ohm,1/2W,Metal
R551	4000132	0.22 ohm \times 2,5.5W + 5.5W,Metal plate
R552	451630824	8.2 ohm,1W,Metal
R553	452530824	8.2 ohm,1/2W,Metal
R554-R556	452534794	0.47 ohm,1/2W,Metal
R557	442522724	2.7 kohm,1/2W,Metal oxide
R921-R923	452534794	0.47 ohm,1/2W,Metal
R924	442523304	33 ohm,1/2W,Metal oxide <D>
	442530824	8.2 ohm,1/2W,Metal <P/W/Q>
R927	441621804	18 ohm,1W,Metal oxide
R928	441722214	220 ohm,2W,Metal oxide
R930,R935	442522204	22 ohm,1/2W,Metal oxide
R934	442523314	330 ohm,1/2W,Metal oxide
	Relaies	
RL501	25065339	NRL-2P5A-DC24-046
RL502	25065379	NRL-1P5A-DC24-058
RL503,RL504	25065339	NRL-2P5A-DC24-046
RL505	25065470	NRL-2P1.25A-DC24-079
RL902,RL903	25065435	Δ NRL-1P10A-DC24-072
	Fuses	
F911,F912	252166Y	Δ 6.3A-UL/T-237 <D>
	252079	Δ 6.3A-SE-EAK <P/W/Q>
	Fuseholders	
F911A,F912A	25050065	Δ YSH403T
	Fuse labels	
	29360622	T6.3A/250V <P/W/Q>
	Plugs	
P201A	25055500	NPLG-12P475
P601A	25055498	NPLG-8P473
P602A	25055499	NPLG-10P474
P603A	25055503	NPLG-18P478
	Terminals	
P301-P303	25045300	NPJ-6PDBL-159
P304	25045303	NPJ-4PDBL-162
P501	25060125	NTM-8PDMN058
	Wire traps	
JL401	25050531	NSCT-9P354
JL701A	25050612 or 25050705	NSCT-32P423 or NSCT-32P509
CENTER SPEAKER TERMINAL PC BOARD (NAETC-4693-5/5A)		
CIRCUIT NO.	PART NO.	DESCRIPTION
P502	25060114	NTM-2PDML048,Speaker terminal
SPEAKER TERMINAL PC BOARD (NAETC-4694-5/5A)		
CIRCUIT NO.	PART NO.	DESCRIPTION
P503	25060161	NTM-4PDML087,Speaker terminal
HEADPHONE TERMINAL PC BOARD (NAETC-4695-5)		
CIRCUIT NO.	PART NO.	DESCRIPTION
P504	25045255	YKB26-5009,Headphone terminal
OUTPUT TERMINAL PC BOARD (NAETC-4696-5)		
CIRCUIT NO.	PART NO.	DESCRIPTION
P432	25045302	NPJ-1PDBL161,Terminal
DISPLAY CIRCUIT PC BOARD (NADIS-4697-5/5A/5B)		
CIRCUIT NO.	PART NO.	DESCRIPTION
	Remote control sensor	
U701	24130007	GP1U571X
	FL tube	
Q703	212120	13-BT-131GK
	ICs	
Q701	22240684	SC78012CW-027
Q702	22240685R9	M66004FP
	Transistors	
Q704,Q705	2213284	2SC1740S-R
Q706	221282	DTC144ES
Q707	2213640	DTC123JS
Q708	2213510	DTA114ES
Q709	2212794	2SD1468-R
	Diodes	
D701-D704	223205 or	1SS270A or
D706,D710	223163	1SS133
D707,D708	224450562	MTZ5.6B
D709	224451303	MTZ13C
D713-D715	223205 or	1SS270A or
	223163	1SS133
D716,D717	225142	SEL2913K,LED
	Resonator	
X701	3010205	CST8.38MTW, Ceramic
	Coils	
L701-L703	233411K220	NCH-1387 220K
	Capacitors	
C701	3000074	0.047F,5.5V,Super
C702,C706	375524744	0.47 μ F \pm 5%,50V,Plastic
C703	354721019	100 μ F,6.3V,Elect.
C704	354780109	1 μ F,50V,Elect.
C708-C710	354780109	1 μ F,50V,Elect.
C717,C737	354721019	100 μ F,6.3V,Elect.
C748	354741009	10 μ F,16V,Elect.
	Resistor	
R714	49163103413	10 kohm \times 13,1/10W,Array
	Switches	
S701-S704	25035548	NPS-111-S510
S706,S708	25035548	NPS-111-S510
S710-S728	25035548	NPS-111-S510
S731-S746	25035548	NPS-111-S510
	Plug	
P702A	25055510	NPLG-3P485

NOTE: <D>: 120V model only
 <P>: 230V model only
 <W>: Worldwide model only
 <Q>: 240V model only

NOTE: THE COMPONENTS IDENTIFIED BY MARK Δ ARE CRITICAL FOR RISK OF FIRE AND ELECTRIC SHOCK. REPLACE ONLY WITH PART NUMBER SPECIFIED.

CIRCUIT NO.	PART NO.	DESCRIPTION
	Wire trap	
JL701B	25050578 or 25050726	NSCT-32P389 or NSCT-32P530
	Holders	
D712A,D716A	27190843	
Q703A	27190913Y	

SURROUND CIRCUIT PC BOARD (NAAF-4698-5/5A)

CIRCUIT NO.	PART NO.	DESCRIPTION
	ICs	
Q451,Q471	22240247 or	BA15218N or
Q601,Q605	22240293	NJM4558L-D
Q499	22240239	TA7291S
Q602	22240683 or 22240692	NJM2177L or M69032P
Q651	22240686 or 22240687	M65830P or NJU9701D
Q671	22240266	TC9213P
Q673,Q674	22240247 or 22240293	BA15218N or NJM4558L-D
Q691	22240339	LC7823N
Q692	22240270	LC7822N
	Transistors	
Q491-Q495	2213631 or	RN1241-A or
Q603,Q604	2213632	RN1241-B
Q496-Q498	2213510	DTA114ES
Q675	2213631 or 2213632	RN1241-A or RN1241-B
	Diodes	
D651,D652	223205 or 223163	1SS270A or 1SS133
	Resonator	
X651	3010217	CST2.04MG040
	Coil	
L651	233411K220	NCH-1387
	Capacitors	
C451,C452	354780229	2.2 μ F,50V,Elect.
C459-C462	354761009	10 μ F,35V,Elect.
C471,C472	354780229	2.2 μ F,50V,Elect.
C479-C482	354761009	10 μ F,35V,Elect.
C491-C493	354761009	10 μ F,35V,Elect.
C494	354721019	100 μ F,6.3V,Elect.
C601,C602	354761009	10 μ F,35V,Elect.
C605,C606	354761009	10 μ F,35V,Elect.
C607-C610	353781099	0.1 μ F,50V,Elect.
C613,C614	374724734	0.047 μ F \pm 5%,50V,Plastic
C615,C616	374722234	0.022 μ F \pm 5%,50V,Plastic
C617-C620	353781099	0.1 μ F,50V,Elect.
C621,C622	354780479	4.7 μ F,50V,Elect.
C623-C627	354782299	0.22 μ F,50V,Elect.
C628	354761009	10 μ F,35V,Elect.

CIRCUIT NO.	PART NO.	DESCRIPTION
	Capacitors	
C629	354786899	0.68 μ F,50V,Elect.
C630	374724734	0.047 μ F \pm 5%,50V,Plastic
C631	374725624	5600pF \pm 5%,50V,Plastic
C632	354780229	2.2 μ F,50V,Elect.
C634	354722219	220 μ F,6.3V,Elect.
C635	354741019	100 μ F,16V,Elect.
C636-C641	354761009	10 μ F,35V,Elect.
C642	374724724	4700 pF \pm 5%,50V,Plastic
C643	354761009	10 μ F,35V,Elect.
C644	392841007	10 μ F,16V,Elect.
C647-C649	354761009	10 μ F,35V,Elect.
C651	354780229	2.2 μ F,50V,Elect.
C653	374723924	3900 pF \pm 5%,50V,Plastic
C655	374726834	0.068 μ F \pm 5%,50V,Plastic
C656	354744709	47 μ F,16V,Elect.
C657,C658	353781099	0.1 μ F,50V,Elect.
C659	374726834	0.068 μ F \pm 5%,50V,Plastic
C660	374725624	5600pF \pm 5%,50V,Plastic
C661	374724724	4700 pF \pm 5%,50V,Plastic
C663,C665	354721019	100 μ F,6.3V,Elect.
C666	375524744	0.47 μ F \pm 5%,50V,Plastic
C671,C672	354780229	2.2 μ F,50V,Elect.
C675,C676	354761009	10 μ F,35V,Elect.
C677,C678	354780229	2.2 μ F,50V,Elect.
C679,C680	354761009	10 μ F,35V,Elect.
C681,C682	354780109	1 μ F,50V,Elect.
C683,C684	374721034	0.01 μ F \pm 5%,50V,Plastic
C685,C686	354761009	10 μ F,35V,Elect.
	Resistor	
R450	5144017Y	N16RQL50KA25F,Variable,Volume
	Sockets	
P601	25050445	NSCT-8P269
P602	25050446	NSCT-10P270
P603	25050450	NSCT-18P274
P611	2000802UL	NSAS-6P758
	Plug	
P621	25055411	NPLG-9P393

RI/MR TERMINAL PC BOARD (NAETC-4699-5)

CIRCUIT NO.	PART NO.	DESCRIPTION
	Transistors	
Q961,Q962	221282	DTC144ES
	Diodes	
D961-D963	223205 or 223163	1SS270A or 1SS133
	Capacitors	
C961	354761009	10 μ F,35V,Elect.
C962	374724724	4700pF \pm 5%,50V,Plastic
	Slide switch	
S961	25065286	NSS-22112 <W>

NOTE: <D>: 120V model only
 <P>: 230V model only
 <W>: Worldwide model only
 <Q>: 240V model only

NOTE: THE COMPONENTS IDENTIFIED BY MARK Δ ARE CRITICAL FOR RISK OF FIRE AND ELECTRIC SHOCK. REPLACE ONLY WITH PART NUMBER SPECIFIED.

CIRCUIT NO.	PART NO.	DESCRIPTION
	Resonator	
X104	3010141 or 3010158	XTL-7.2M,Crystal
	Capacitors	
C001	354741019	100 μ F,16V,Elect.
C108,C124	354741019	100 μ F,16V,Elect.
C112,C118	354780229	2.2 μ F,50V,Elect.
C113	354784799	0.47 μ F,50V,Elect.
C117	374723334	0.033 μ F \pm 5%,50V,Plastic
C119,C205	354782299	0.22 μ F,50V,Elect.
C123,C152	354721019	100 μ F,6.3V,Elect.
C154	354780479	4.7 μ F,50V,Elect.
C155-C157	354761009	10 μ F,35V,Elect.
C159	374724734	0.047 μ F \pm 5%,50V,Plastic
C160	374721034	0.01 μ F \pm 5%,50V,Plastic
C161	353782299	0.22 μ F,50V,Elect.
C201	354744719	470 μ F,16V,Elect.
C202	354742209	22 μ F,16V,Elect.
C206	353780109	1 μ F,50V,Elect.
C207	354780339	3.3 μ F,50V,Elect.
C208	370134714	470pF \pm 5%,100V,Plastic
C209,C224	374724734	0.047 μ F \pm 5%,50V,Plastic
C211,C212	374721824	1800pF \pm 5%,50V,Plastic <D>
	374721224	1200pF \pm 5%,50V,Plastic <P/Q>
	374721524	1500pF \pm 5%,50V,Plastic <W>
C213,C214	354742209	22 μ F,16V,Elect.
C215,C216	354761009	10 μ F,35V,Elect.
C219,C220	374726824	6800pF \pm 5%,50V,Plastic <D>
	374724724	4700pF \pm 5%,50V,Plastic <P/Q>
	374725624	5600pF \pm 5%,50V,Plastic <W>
C222	354780229	2.2 μ F,50V,Elect.
C223	374721024	1000pF \pm 5%,50V,Plastic
C225,C226	354761009	10 μ F,35V,Elect.
	Trim resistors	
R101	5210266	N06HR100KBC
R201	5210261	N06HR5KBC
R202	5210267	N06HR200KBC
	Terminal	
P101	25060160	NTM-4PDMN086 <D>
	25060117	NTM-2PDMN051 <P/W/Q>
	Socket	
P201	25050447	NSCT-12P271
POWER SUPPLY CIRCUIT PC BOARD (NAPS-4702-5/5A/5B/5C/5D)		
CIRCUIT NO.	PART NO.	DESCRIPTION
	Transistors	
Q951	221282	DTC144ES
Q952	2213650	DTD113ZS
	Diodes	
D951-D954	22380046 or 22380035	AM01Z or GP104003E

CIRCUIT NO.	PART NO.	DESCRIPTION
	Jacks	
P961	25045293	HSJ-1003-01-012
P962	25045172	HSJ-1003-01-020
	Wire trap	
JL961	25050527	NSCT-5P350
STC SWITCH PC BOARD (NASW-4700-5)		
CIRCUIT NO.	PART NO.	DESCRIPTION
S729	25035548	NPS-111-S510,Switch
P702B	25050454	NSCT-3P278,Socket
TUNER CIRCUIT PC BOARD (NARF-4701-5/5A/5B)		
CIRCUIT NO.	PART NO.	DESCRIPTION
	Front end	
TU001	240088	FE337-A07 <D>
	240089	FE415-G11 <P/W/Q>
	ICs	
Q104	22240039	LA1266
Q107	22240090	LM7001
Q201	22240242	AN7470
Q208	22240247 or 22240293	BA15218N or NJM4558L-D
	Transistors	
Q101	2210746	2SC945A-P <P/W/Q>
Q102	2211723	2SC1923-O
Q105	2212445	2SK365-GR
Q106	2213284	2SC1740S-R
Q108,Q109	2213510	DTA114ES
Q205,Q206	2212794	2SD1468-R
Q207	2213510	DTA114ES
	Diodes	
D103	224450512	MTZ5.1B
D201,D202	223205 or	1SS270A or
D206,D207	223163	1SS133
	Transformers	
L101	233401	NFIF-4072
L102	233402	NFIF-4073
L152	232139	NMIF-4062
	Coils	
L103	233411M022	NCH-1375 022M
L104	233383	NMC-6070 <P/W/Q>
L151	232148	NMRF-7050
L201,L202	233355A	NMC-4059
	Ceramic filters	
X101,X103	3010071	SFE10.7MA5 <D>
X101,X102	3010071	SFE10.7MA5 <P/W/Q>
X103	3010130	SFE10.7M22A <P/W/Q>
X151	3010123	SFZ-450JL
X152	3010076	BFU-450C

CAUTION: Replacement for transistor of mark ☆, if necessary, must be made from the same beta group (H FE) as the original type.

NOTE: THE COMPONENTS IDENTIFIED BY MARK Δ ARE CRITICAL FOR RISK OF FIRE AND ELECTRIC SHOCK. REPLACE ONLY WITH PART NUMBER SPECIFIED.

CIRCUIT NO.	PART NO.	DESCRIPTION
	Diodes	
D955-D957	223205 or 223163	1SS270A or 1SS133
	Power transformer	
T902	2300670 2300671 2300672 2300673	Δ NPT-1111D <D> Δ NPT-1111P <P> Δ NPT-1111DG <W> Δ NPT-1111Q <Q>
	Relay	
RL901	25065248	Δ NRL-1P15A-DC12-29
	Capacitors	
C901	3500065A	Δ DE7150FZ103PAC400/125V,IS
C952	354742219	220 μ F, 16V, Elect.
	Resistors	
R901	431523355	Δ 3.3 Mohm, 1/2W, Solid <D>
R951	452530824	Δ 8.2 ohm, 1/2W, Metal
	Fuse	
F901	252166Y	Δ 6.3A-UL/T-237 <D/W>
F902	252076	Δ 3.15A-SE-EAK <P/W/Q>
F903	252075	Δ 2.5A-SE-EAK <P>
	Fuseholders	
F901A	25050065	Δ YSH403T <D/W>
F902A	25050065	Δ YSH403T <P/W/Q>
F903A	25050065	Δ YSH403T <P>
	AC outlet	
P902	25050409 25050640	Δ NSCT-4P234 <D> Δ NSCT-4P451 <P/W>
	Slide switch	
S901	25065437	Δ NSS-22157P <W>

REAR AMPLIFIER PC BOARD (NAAF-4703-5)

CIRCUIT NO.	PART NO.	DESCRIPTION
	ICs	
Q571, Q572	22240108	μ PC1225H
	Transistors	
Q562, Q563	2211732 or	2SC1845-F or
Q579, Q580	2211733	2SC1845-E
Q573, Q574	2213284	2SC1740S-R
Q575, Q576	2202063, 2202064 or 2202066	☆ 2SC4511-O, ☆ 2SC4511-Y or ☆ 2SC4511-P
Q577, Q578	2202053, 2202054 or 2202056	☆ 2SA1725-O, ☆ 2SA1725-Y or ☆ 2SA1725-P
	Coils	
L571, L572	231209S	S-0.4A
	Capacitors	
C563	354721019	100 μ F, 6.3V, Elect.
C571, C572	354761009	10 μ F, 35V, Elect.
C577, C578	354721019	100 μ F, 6.3V, Elect.
C585, C586	374723334	0.033 μ F \pm 5%, 50V, Plastic

CIRCUIT NO.	PART NO.	DESCRIPTION
	Capacitors	
C587, C588	374724734	0.047 μ F \pm 5%, 50V, Plastic
C595, C596	354761009	10 μ F, 35V, Elect.
	Resistors	
R585, R586	4000131	0.22 ohm \times 2, 2W+2W, Metal plate
R587-R590	452530824	8.2 ohm, 1/2W, Metal
R597	452530824	8.2 ohm, 1/2W, Metal
	Plug	
P611A	25055234	NPLG-3P218
	Wire traps	
JL571	25050280	NSCT-3P108
JL572	25050282	NSCT-5P110

TONE CONTROL CIRCUIT PC BOARD (NAAF-4704-5)

CIRCUIT NO.	PART NO.	DESCRIPTION
	ICs	
Q401, Q402	22240247 or 22240293	BA15218N or NJM4558L-D
	Transistors	
Q403-Q406	2211945	2SK246-GR
	Diodes	
D401-D404	223205 or 223163	1SS270A or 1SS133
	Capacitors	
C401, C402	354761009	10 μ F, 35V, Elect.
C405, C406	354744709	47 μ F, 16V, Elect.
C407, C408	374721534	0.015 μ F \pm 5%, 50V, Plastic
C411, C412	374721534	0.015 μ F \pm 5%, 50V, Plastic
C413-C416	374721044	0.1 μ F \pm 5%, 50V, Plastic
C417-C420	374721024	1000pF \pm 5%, 50V, Plastic
	Variable resistors	
R393	5104225	N11RGLC250KWT22Z, Balance
R407, R413	5104230	N14RLC100KWT22Z, Tone

VIDEO CIRCUIT PC BOARD (NAETC-4705-5)

CIRCUIT NO.	PART NO.	DESCRIPTION
	IC	
Q251	22240373	BA7625
	Transistors	
Q252-Q254	2213354	2SA933S-R
	Diodes	
D251	22380046 or 22380035	AM01Z or GP104003E
	Capacitors	
C251, C253, C255	354780229	2.2 μ F, 50V, Elect.
C252, C254	354724719	470 μ F, 6.3V, Elect.
C258	354724719	470 μ F, 6.3V, Elect.
C259	354721019	100 μ F, 6.3V, Elect.
	Terminals	
P251	25045339	NPJ-4PDYE-190
P252	25045395Y	NPJ-2PDYE-221

PACKING VIEW

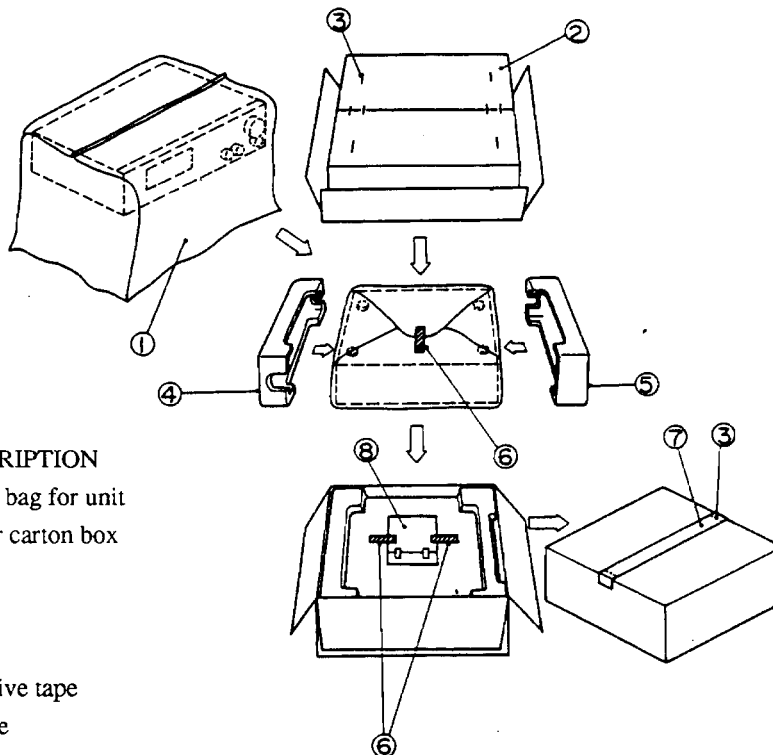

REF.NO.	PART NO.	DESCRIPTION
1	29100034-1	Styren bag for unit
2	29052785Y	Master carton box
3	282301	Staple
4	29091615BY	Pad R
5	29091614BY	Pad L
6	261504	Adhesive tape
7	29110071	PP tape
8	Accessory bag ass'y	
	29341975Y	Instruction manual
	29341978Y	Instruction manual <P/W/C>
	29341980Y	Instruction manual <W>
	2010200	Connection cord RI
	3010054	UM-3,Two batteries
	24140252Y	RC-252S,Remote control transmitter
	232140	NMA-3057,AM loop antenna
	292111Y	FM antenna <D>
	292112Y	FM antenna <P/W/Q>
	25065462Y	YAE21-0237, FM antenna adaptor <W/Q>
	25055018	CV-K-1,Conversion plug <W>
	25055251	CV-CP,Conversion plug <PX>
	29365019A	Warranty card <N>
	29365021	Warranty card <PX>
	29358002K	Service station list <N/PX>
	29100097-1Y	Styren bag for accessory

NOTE: <D>:120V model only
 <P>:230V/240V models only
 <W>:Worldwide model only
 <N>:U.S.A. model only
 <PX>:PX model only
 <C>:Canadian model only

ONKYO CORPORATION

International Division: 2-1, Nisshin-cho, Neyagawa-shi, OSAKA 572, JAPAN
 Tel: 0720-31-8133 Fax: 0720-34-1340

ONKYO U.S.A. CORPORATION

200 Williams Drive, Ramsey, N.J. 07446, U.S.A.
 Tel: 201-825-7950 Fax: 201-825-8150

ONKYO Europe GmbH

Immeuble Le DIAMANT, Domaine Technologique De Saclay, 4 rue Rene Razel,
 91892 SACLAY, FRANCE Tel: (1)69 33 14 15 Fax: (1)69 41 29 66

ONKYO FRANCE S.A.R.L.

Immeuble Le DIAMANT, Domaine Technologique De Saclay 4 rue Rene Razel,
 91892 SACLAY, FRANCE Tel: (1)69 41 35 10 Fax: (1)69 41 35 84