

ONKYO® SERVICE MANUAL

AUDIO VIDEO CONTROL RECEIVER MODEL TX-SV545

Black and Silver models

BMD	120V AC,60Hz
BMP,BMPT,BMPA,SMP	230V AC,50Hz
BMWT	220-230V/120V AC,50/60Hz
BMGK	220V AC,50Hz

SAFETY-RELATED COMPONENT WARNING!!

COMPONENTS IDENTIFIED BY MARK \triangle ON THE SCHEMATIC DIAGRAM AND IN THE PARTS LIST ARE CRITICAL FOR RISK OF FIRE AND ELECTRIC SHOCK. REPLACE THESE COMPONENTS WITH ONKYO PARTS WHOSE PART NUMBERS APPEAR AS SHOWN IN THIS MANUAL.

MAKE LEAKAGE-CURRENT OR RESISTANCE MEASUREMENTS TO DETERMINE THAT EXPOSED PARTS ARE ACCEPTABLY INSULATED FROM THE SUPPLY CIRCUIT BEFORE RETURNING THE APPLIANCE TO THE CUSTOMER.

TABLE OF CONTENTS

Specifications.....	2
Service procedures.....	3
Adjustment procedures.....	4
Tuner section.....	4
Amplifier section.....	38
Microprocessor connection diagram.....	6
Microprocessor terminal descriptions.....	7
IC block diagrams and descriptions.....	8
Printed circuit board parts list.....	15
Volume section.....	25
Tuner section.....	42
Video section.....	50
Block diagrams.....	19
Amp. section.....	19
Tuner section.....	51
Printed circuit board view.....	21
Main circuit section.....	21
Volume section.....	26
Display and switch sections.....	29
Power supply and amp. sections.....	33
Power amplifier section.....	37
Tuner section.....	41
Video section.....	49
Schematic diagrams.....	23
Main circuit section.....	23
Volume section.....	27
Display and switch sections.....	31
Power supply and amp. sections.....	35
Power amplifier section.....	39
Tuner section.....	43
Video section.....	49
Exploded view.....	45
Parts list.....	47
Packing view.....	52



SPECIFICATIONS

AMPLIFIER SECTION

Power Output

U.S. & Canadian models:

Stereo mode

Front L/R channels: **75 watts per channel, min. RMS at 8 ohms, both channels driven from 20 Hz to 20 kHz with no more than 0.08% total harmonic distortion.**

Surround mode

Front L/R and Center channels: **65 watts per channel, min. RMS at 8 ohms, three channels driven from 20 Hz to 20 kHz with no more than 0.08% total harmonic distortion.**

Surround L/R channels: **25 watts per channel, min. RMS at 8 ohms, both channels driven from 20 Hz to 20 kHz with no more than 0.3% total harmonic distortion.**

(Rear only driven)

Remote mode

25 watts per channel, min. RMS at 8 ohms, both channels driven from 20 Hz to 20 kHz with no more than 0.08% total harmonic distortion.

Other area models:

Stereo mode

Front L/R channels: 2 × 100 watts at 6 ohms, 1 kHz (DIN)

Surround mode

Front L/R and Center channels: 3 × 95 watts at 6 ohms, 1 kHz (DIN)

Surround L/R channels: 2 × 35 watts at 6 ohms, 1 kHz (DIN)

(Rear only driven)

Remote mode

2 × 30 watts at 6 ohms, 1 kHz (DIN)

IM Distortion: 0.08% at rated power (Front)

Damping Factor: 60 at 8 ohms (Front)

Input Sensitivity/Impedance

PHONO: 2.5 mV/50 kohms

CD/TAPE 1, 2/VIDEO-1, 2, 3: 200 mV/50 kohms

MULTI CHANNEL INPUT

(FRONT L/R, SUR-

ROUND L/R, CENTER): 200 mV/50 kohms

MULTI CHANNEL INPUT

(SUBWOOFER): 36 mV/50 kohms

Output Level/Impedance

REC OUT: 200 mV/2.2 kohms

PRE OUT: 1 V/470 ohms

Phono Overload: 120 mV RMS at 1 kHz, 0.5% T.H.D.

Frequency Response: 20 Hz to 30 kHz, ±1 dB (Surround OFF)

RIAA Deviation: 20 Hz to 20 kHz, ±0.8 dB

Tone Control

Bass: ±10 dB at 50 Hz

Treble: ±10 dB at 10 kHz

Signal-to-Noise Ratio

(Surround OFF)

Phono: 80 dB (IHF A, 5 mV input)

CD/Tape: 100 dB (IHF A)

Muting: ∞ dB

VIDEO SECTION

Input Sensitivity and Impedance

Video (Composite): 1 Vp-p/75 ohms

Output Level and Impedance

Video (Composite): 1 Vp-p/75 ohms

TUNER SECTION

FM

Tuning Range: 87.5 — 108.0 MHz (50 kHz steps)

Usable Sensitivity

Mono: 11.2 dBf, 1.0 μV (75 ohms)

Stereo: 17.2 dBf, 2.0 μV (75 ohms)

50 dB Quieting Sensitivity

Mono: 17.2 dBf, 2.0 μV (75 ohms)

Stereo: 37.2 dBf, 20 μV (75 ohms)

Capture Ratio: 1.5 dB

Image Rejection Ratio

U.S. & Canadian models: 40 dB

Other area models: 85 dB

IF Rejection Ratio: 90 dB

Signal-to-Noise Ratio

Mono: 76 dB

Stereo: 70 dB

Alternate Channel Attenuation: 55 dB

Selectivity: 50 dB (DIN)

AM Suppression Ratio: 50 dB

Total Harmonic Distortion

Mono: 0.1%

Stereo: 0.2%

Frequency Response: 30 Hz — 15 kHz, ±1.0 dB

Stereo Separation: 45 dB at 1 kHz

30 dB at 70 Hz — 10 kHz

Muting level: 17.2 dBf

AM

Tuning Range

U.S. & Canadian models: 530—1,710 kHz (10 kHz steps)

European & Australian models: 522—1,611 kHz (9 kHz steps)

Worldwide models: 531—1,602 kHz (9 kHz steps), 530—1,710 kHz (10 kHz steps)

Usable Sensitivity: 30 μV

Image Rejection Ratio: 40 dB

IF Rejection Ratio: 40 dB

Signal-to-Noise Ratio: 40 dB

Total Harmonic Distortion: 0.7%

GENERAL

Power Supply

AC 120 V, 60 Hz

AC 220 V, 60 Hz

AC 230 V, 50 Hz

AC 220-230 V and 120 V switchable, 50/60 Hz

Power Consumption

U.S. & Canadian models: 3.5 A

Other area models: 310 W

Dimensions (W × H × D): 435 × 175 × 390 mm

17-1/8" × 6-7/8" × 15-3/8"

Weight:

U.S. & Canadian models: 11.7 kg, 25.8 lbs.

Other area models: 12.5 kg, 27.6 lbs.

REMOTE CONTROL

U.S. & Canadian models: RC-343M

Other area models: RC-344S

Transmitter: Infrared

Signal range: Approx. 5 meters, 16 ft.

Power supply: Two "AA" batteries (1.5 V × 2)

Specifications and features are subject to change without notice.

SERVICE PROCEDURES

1. Replacing the fuses

 This symbol located near the fuse indicates that the fuse used is fast operating type. For continued protection against fire hazard, replace with same type fuse. For fuse rating refer to the marking adjacent to the symbol.

 Ce symbole indique que le fusible utilise est a rapide. Pour une protection permanente, n'utiliser que des fusibles de meme type. Ce dernier est indique la qu le present symbol est appose.

CIRCUIT NO.	PART NO.	DESCRIPTION
F901	252198	8A-UL, Primary fuse <D/W>
F902	252077	4A-SE-EAK, Primary fuse <P/T/W/A/K>
F903	252075	2.5A-SE-EAK, Fuse <P>
	252074	2A-SE-EAK, Fuse <T/A>
F915.F916	252166	6.3A-UL/T-237, Secondary fuse <D>
	252079	6.3A-SE-EAK, Secondary fuse <P/T/W/A/K>

NOTE: <D>: 120V model only
 <P>: European model only
 <T>: Asian model only
 <W>: Worldwide model only
 <A>: Australian model only
 <K>: Korean model only

2. To Initialize the unit

This device employs a microprocessor to perform various functions and operations. If interference generated by an external power supply, radio wave, or other electrical source results in accident which causes the specified operations and functions to operate abnormally.

To perform a result, please follow the procedure below.

1. Press and hold down the CD button, then press the POWER button.
2. After "clear" is displayed, the prest memory and each mode stored in the memory, such as surround, are initialized and will return to the factory settings.

3. Safety-check out

(Only U.S.A. model)

After correcting the original service problem, perform the following safety check before releasing the set to the customer. Connect the insulating-resistance tester between the plug of power supply cord and the screw on the back panel.

Specifications: 3.3 Mohm \pm 10% at 500V.

4. Change of voltage

Worldwide models are equipment with a voltage selector to conform with local power supplies. This switch is located on the back panel.

Be sure to set this switch to match the voltage of the power supply in your area before turning the power switch on.

This switch is set to 220V at the factory. Voltage is changed by sliding the groove in the switch with the screwdriver to the right

or left. Confirm that the switch has been moved all the way to the right or left before turning the power switch on.

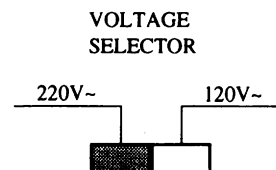

5. Memory preservation

This unit does not require memory preservation batteries.

A built-in memory power back-up system preserves contents of the memory during power failures and even when the unit is unplugged.

The unit must be plugged in and the power switch turned on and off once in order to charge the back-up system. Note that since this is not a permanent memory, the power switch must be turned on and off a few times each month the keep the back-up system operative.

The period of the time during which memory contents are preserved after power has last been turned off varies depending on climate and placement of the unit. On the average, memory contents are protected over a period of 3 to 4 weeks (a minimum of 2 weeks) after the last time power has been turned off. This period is shorted when the unit is exposed to very high humidity or used in an area with an extremely humid climate.

6. Setting the tuning step frequency

Worldwide models are equipped with a step band selector switch. This switch is located on the back panel. This switch is set to 9 kHz at the factory, but may have to be reset to 10 kHz depending on the area where the unit is used.

AM band step
 Europe: 9 kHz
 U.S.A.: 10 kHz

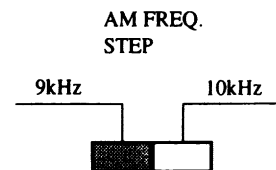

7. Changing the band step

With the exception of the worldwide models, a tuning step selector switch is not provided. When you change the band step, change the parts as shown below.

	To 10 kHz	To 9 kHz
R745	No connection	2.7 kohm
R746	10 kohm	1.5 kohm

ADJUSTMENT PROCEDURES

FM

Item	Step	Connection of instrument	FM SG output	Stereo modulator output	Tuning frequency	Output indicator	Adjustment point	Adjust for	Remarks
FM IF/RF	1	Fig.1	99.0MHz 1kHz 75kHz devi. 65dBf(60dB)	—	99.0MHz	DC voltmeter	L101	0±20mV	FM MUTE/MODE switch:ON/STEREO Repeat the steps 1 and 3 until no further adjustment is necessary.
	AC voltmeter					IFT on the front end	Maximum		
	Distortion analyzer					L102	Minimum		
Stereo Distortion		Fig.2	99.0MHz Ext. mod. 65dBf(60dB)	Channel L or R 1kHz	99.0MHz	Distortion analyzer	IFT on the front end	Minimum	Don't turn more than ±180°
Stereo Separation	1	Fig.2	99.0MHz Ext. mod. 65dBf(60dB)	Channel L 1kHz	99.0MHz	Channel R AC voltmeter	R150	Minimum	Maximum and same separation
	2			Channel R 1kHz		Channel L AC voltmeter		Minimum	
Muting Level		Fig.3	99.0MHz 19.2dBf(14dB)	—	99.0MHz	TUNED indicator	R158	Light on	

AM

120V model

Step	AM SG output	Tuning Frequency	Output Indicator	Adjustment point	Adjust for
1		530kHz	Digital DC voltmeter	OSC coil on RF block L105	1.4±0.2V
2	600kHz 400Hz 30% mod. 60dB/m	600kHz	AC voltmeter	RF coil on RF block L105	Maximum
3	990kHz 400Hz 30% mod. 60dB/m	990kHz	AC voltmeter	L106	Maximum

Reference Specification
 FM tuned voltage: 87.50MHz~108.00MHz
 More than 1.3V~Less than 9V
 AM tuned voltage: 530kHz~1710kHz
 1.4±0.4~Less than 9.0V

230V and Worldwide models

Step	AM SG output	Tuning Frequency	Output Indicator	Adjustment point	Adjust for
1		522kHz or 531kHz	Digital DC voltmeter	OSC coil on RF block L105	1.4±0.2V
2	603kHz 400Hz 30% mod. 60dB/m	603kHz	AC voltmeter	RF coil on RF block L105	Maximum
3	999kHz 400Hz 30% mod. 60dB/m	999kHz	AC voltmeter	L106	Maximum

Reference Specification
 FM tuned voltage: 87.50MHz~108.00MHz
 More than 1.3V~Less than 9V
 AM tuned voltage: 522kHz~1611kHz
 1.4±0.4~Less than 9.0V
 (230V model)

AM tuned voltage: 531kHz~1602kHz
 1.4±0.4~Less than 9.0V
 (Worldwide model)

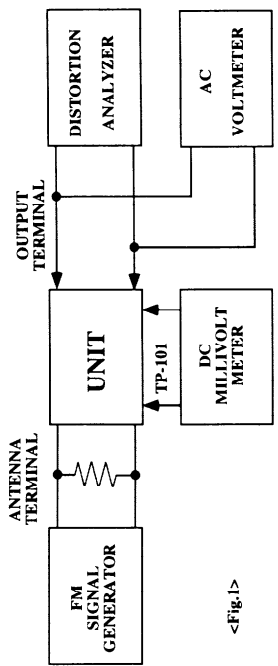

<Fig.1>

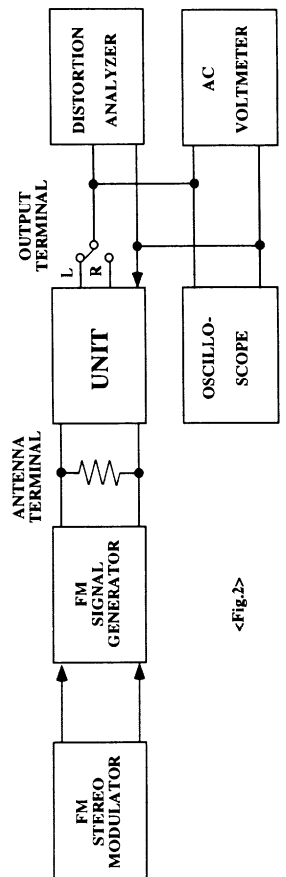

<Fig.2>

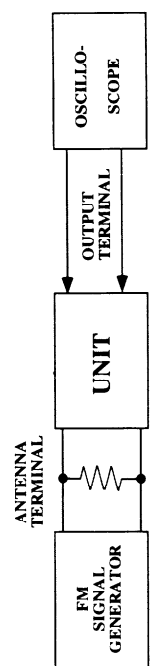

<Fig.3>

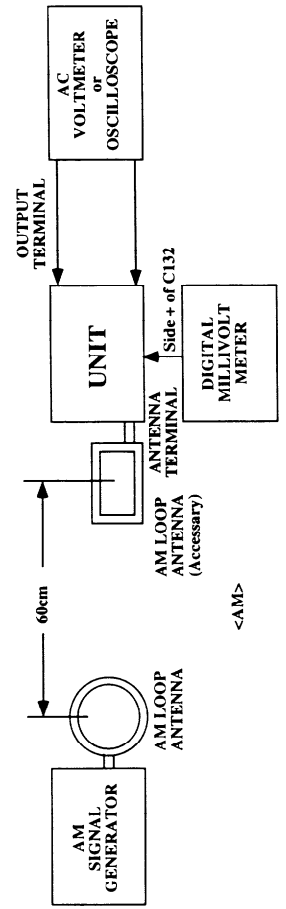

<AM>

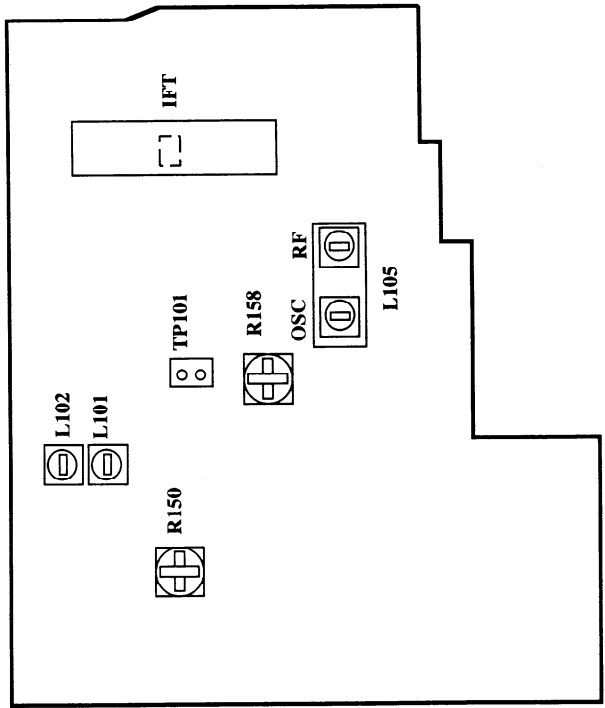

MICROPROCESSOR CONNECTION DIAGRAM

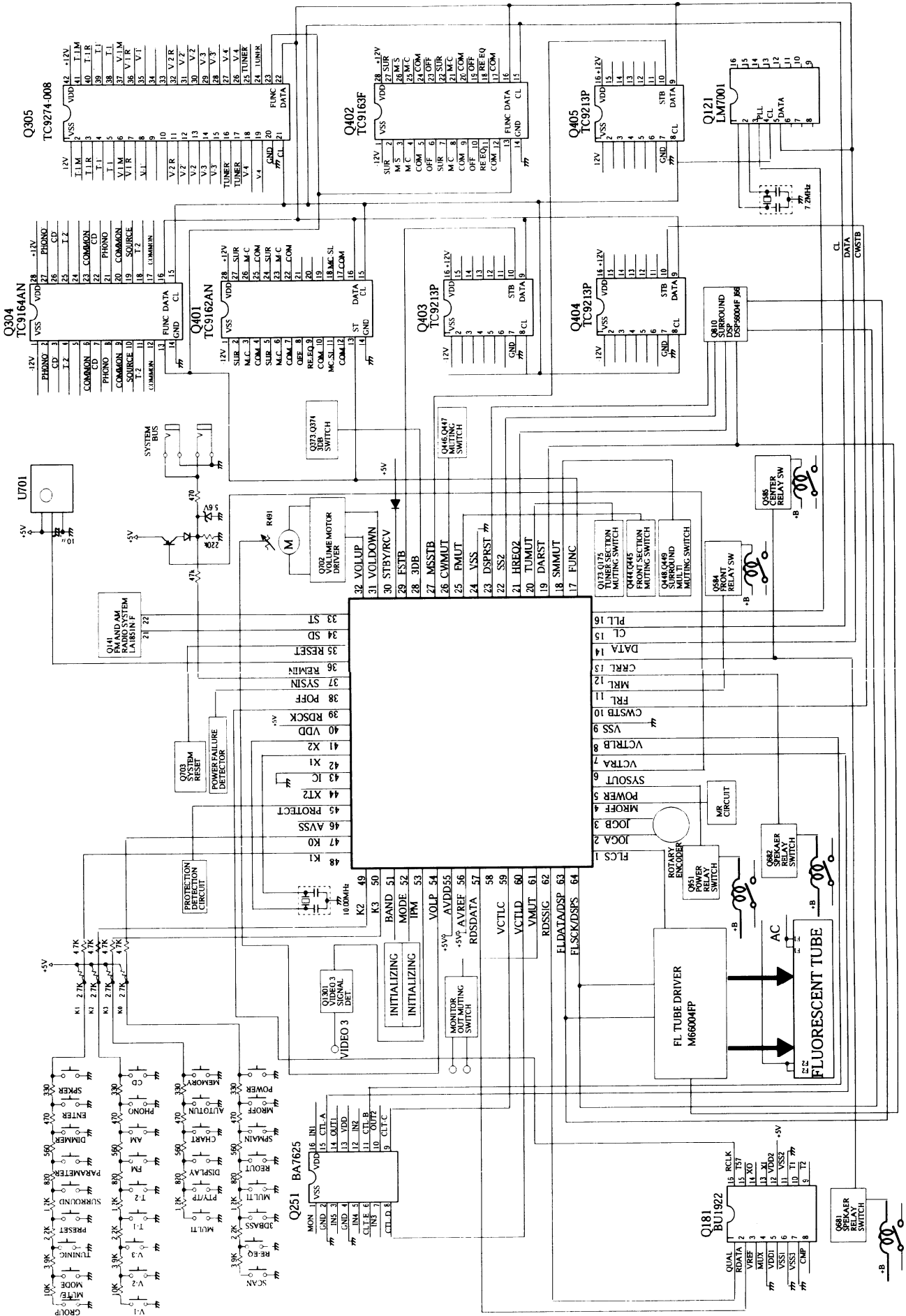

MICROPROCESSOR TERMINAL DESCRIPTIONS

Pin No.	Symbol	Description												
1	FLCS	Connect to the terminal CS of FL tube driver.												
2	JOGA	Input pin of Jog A												
3	JOGB	Input pin of Jog B												
4	MROFF	Multi-Room control output pin												
5	POWER	Power source control output pin												
6	YSOUT	System code output pin												
7	VCTLA	Video output control pin												
8	VCTLB	Video output control pin												
9	VSS	Ground pin												
10	CWSTB	Connect to the terminal STAB of electro volume IC.												
11	FRL	Front speaker relay control output pin												
12	MRL	Multi speaker relay control output pin												
13	GRRL	Center and surround speaker relay control output pin												
14	DATA	Data output pin to Function switch, PLL and electro volume Ics.												
15	CL	Clock output pin to Function switch, PLL and electro volume Ics.												
16	PLL	Chip enable output pin to PLL IC.												
17	FUNC	Strobe output pin to Function switch Ics												
18	MSMUT	Muting output pin for surround multi amplifier.												
19	DARST	Reset output pin for D/A converter												
20	TUMUT	Muting output pin for tuner circuit												
21	HREQ	Request input pin from terminal HREQ of DSP IC.												
22	SS	Output pin to connect the terminal SS of DSP IC.												
23	DSRST	Output pin to connect the terminal RESET of DSP IC.												
24	VSS	Ground pin												
25	FMUT	Muting output pin for amplifier of front channels												
26	CWMUT	Muting output pin for amplifier of center and sub woofer channels												
27	MSSTB	Strobe output pin to Electro volume												
28	3DB	3-D BASS control output pin												
29	FSTB	Strobe output pin to Electro volume												
30	STBY/RECV	STAND-BY and RECEIVED indicator output pin												
31	VOLLDOWN	Volume control output pin												
32	VOLLUP	<table border="1" style="display: inline-table; vertical-align: middle;"> <tr> <td>Operation</td> <td>VOLUP</td> <td>VOLDOWN</td> </tr> <tr> <td>STOP</td> <td>H</td> <td>H</td> </tr> <tr> <td>UP</td> <td>H</td> <td>L</td> </tr> <tr> <td>DOWN</td> <td>L</td> <td>H</td> </tr> </table>	Operation	VOLUP	VOLDOWN	STOP	H	H	UP	H	L	DOWN	L	H
Operation	VOLUP	VOLDOWN												
STOP	H	H												
UP	H	L												
DOWN	L	H												
33	STEREO	Stereo broadcast detection input pin												

Pin No.	Symbol	Description
34	SD	Broadcast detection input pin
35	RESET	System reset input pin
36	REMIN	Input pin from remote control
37	YSIN	System code input pin
38	POFF	Power failure detection input pin
39	RDSSCK	Clock input pin from RDS decoder
40	VDD	Power supply pin (+5V)
41	X2	Ceramic oscillator connection pins of main system clock
42	X1	Connect the 10MHz ceramic oscillator.
43	IC	Internal connection pin
44	XT2	Not used.
45	PROTECT	Protect circuit detection input pin
46	AVSS	Ground pin of A/D converter
47	K0	Operation key connection pins
48	K1	
49	K2	
50	K3	
51	BAND	Initializing input pin for band and RDS function
52	MODE	Initializing input pin for operation mode
53	IPM	Detection input pin of Intelligent Power Management operation
54	VOLP	Position detection input pin of master volume
55	AVDD	Analog power supply pin of A/D converter
56	AVREF	Reference voltage input pin of A/D converter
57	RDSDATA	Data input pin from RDS decoder
58	NC	Not connected
59	VCTLC	Video output control pin
60	VCTLD	Video output control pin
61	VMUT	Muting output pin of video
62	RDSSIG	RDS broadcast detection input pin
63	DSPSO	Input pin from terminal MOSI of DSP IC
	FLDATA	Data output pin from terminal SDATA of FL tube
	DSPSCK	Clock input pin from terminal SCLK of DSP IC
	FLSCK	Clock output pin to connect to terminal SCK of FL tube driver

IC BLOCK DIAGRAMS AND DESCRIPTIONS

TC9162AN (Analog Switch)

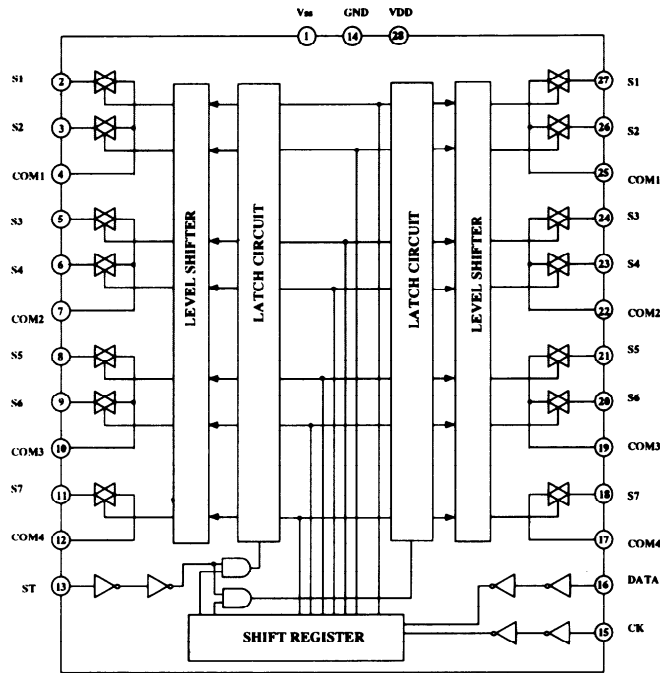

Pin No.	Symbol	Function
1	Vss	Power supply pin (-)
14	GND	Ground pin
28	VDD	Power supply pin (+)
2,3,5,6,8,9,11	S1 ~ S7	Switch input/output pins
27,26,24,23,21,20,18	S1 ~ S7	Switch input/output pins
4,7,10,12	COM1 ~ COM4	Common pins
25,22,19,17	COM1 ~ COM4	Common pins
13	ST	Strobe input pin for data interruption
15	CK	Clock input for data transfer
16	DATA	Serial data input pin for switch setting

TC9274N-008 (Analog Switch)

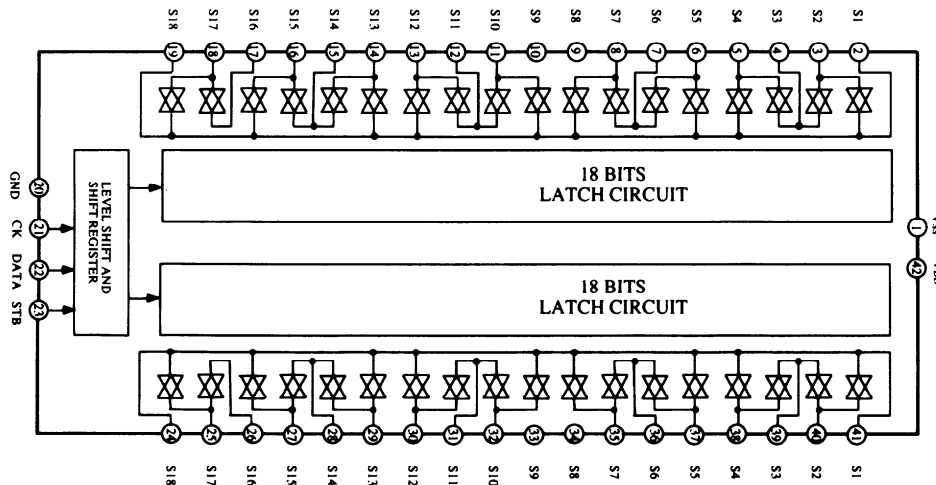

TC9163AN (Analog Switch)

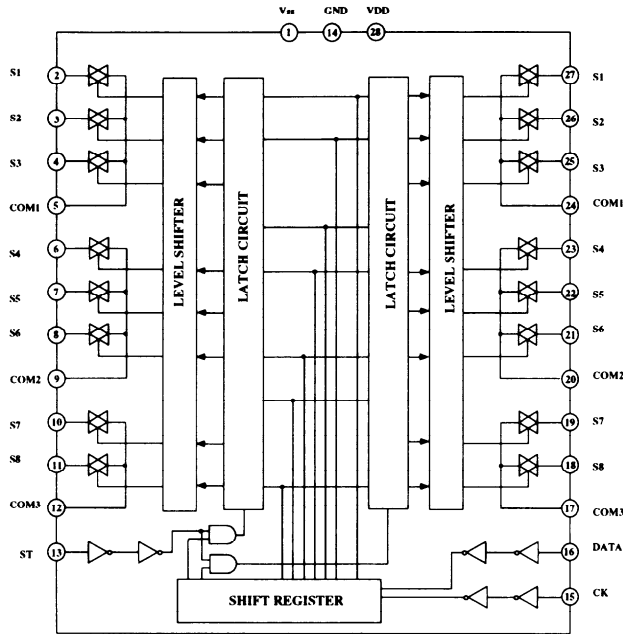

Pin No.	Symbol	Function
1	Vss	Power supply pin (-)
14	GND	Ground pin
28	VDD	Power supply pin (+)
2,3,4,6,7,8,10,11	S1 ~ S8	Switch input/output pins
27,26,25,24,22,21,19,18	S1 ~ S8	Switch input/output pins
5,9,12	COM1 ~ COM3	Common pins
24,20,17	COM1 ~ COM3	Common pins
13	ST	Strobe input pin for data interruption
15	CK	Clock input for data transfer
16	DATA	Serial data input pin for switch setting

TA7291 (Volume Motor Driver)

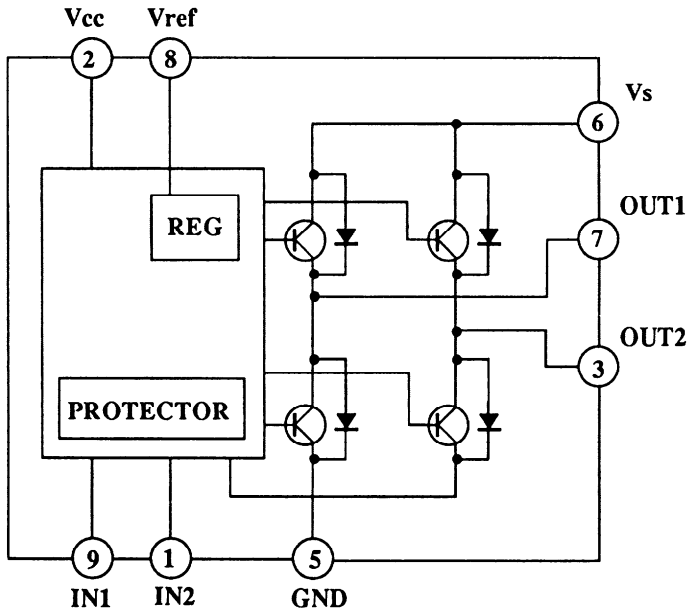

INPUT		OUTPUT		MODE
IN1	IN2	OUT1	OUT2	
0	0	∞	∞	STOP
1	0	H	L	CW/CCW
0	1	L	H	CCW/CW
1	1	L	L	BRAKE

CCW:Counter-clockwise direction
 CW:Clockwise direction

TC9213P (Electro Volume)

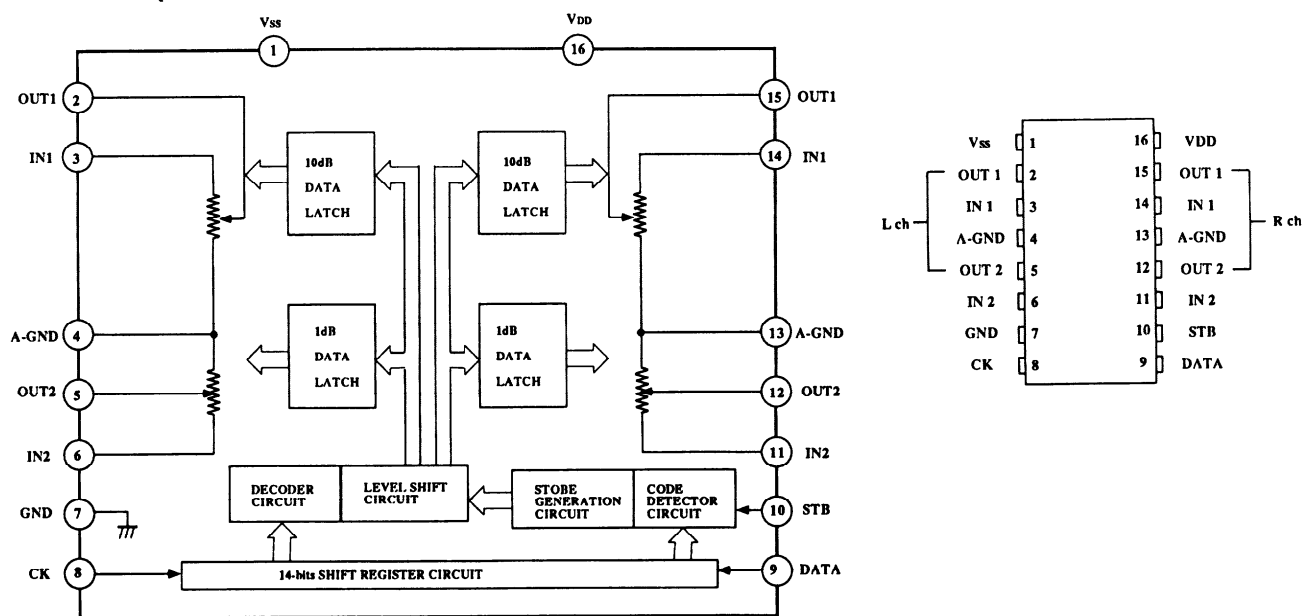

TC9164AN (Analog Switch)

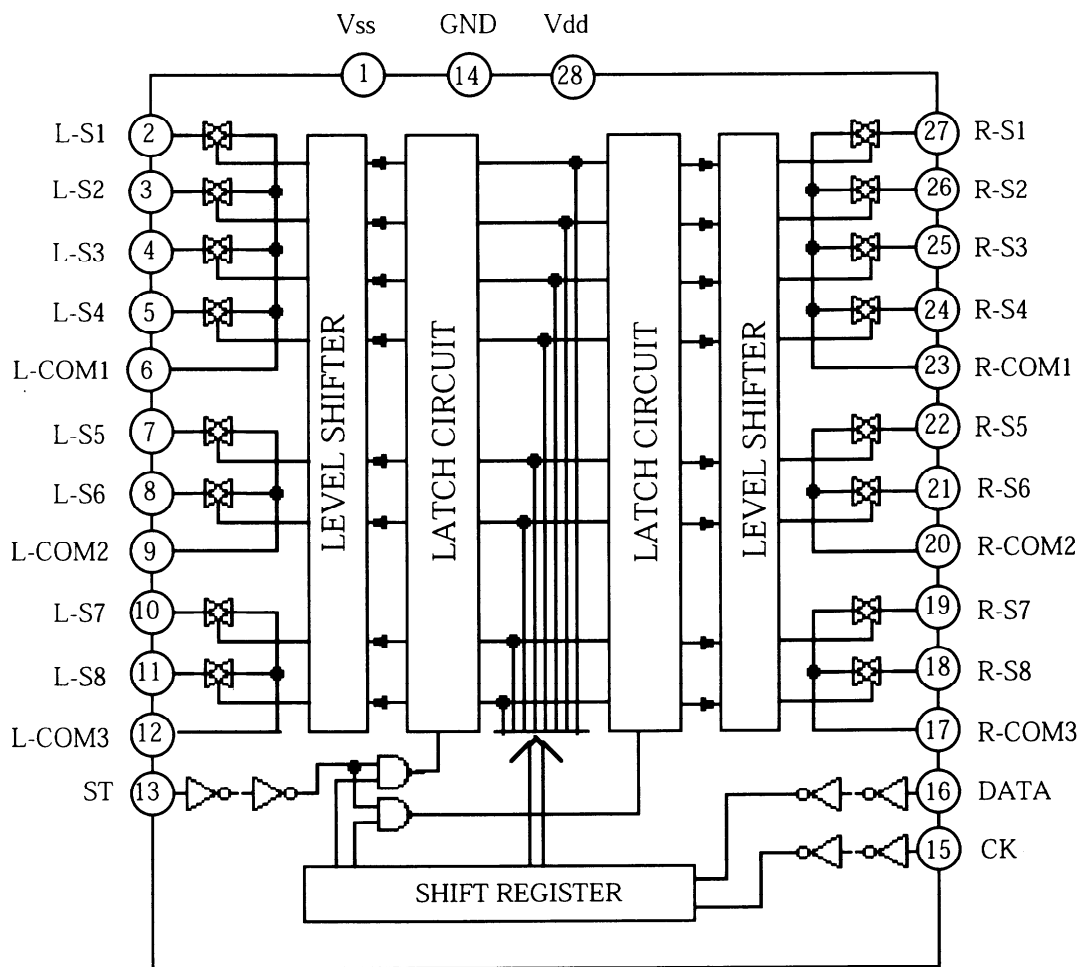

M6604FP (FL Tube Driver)

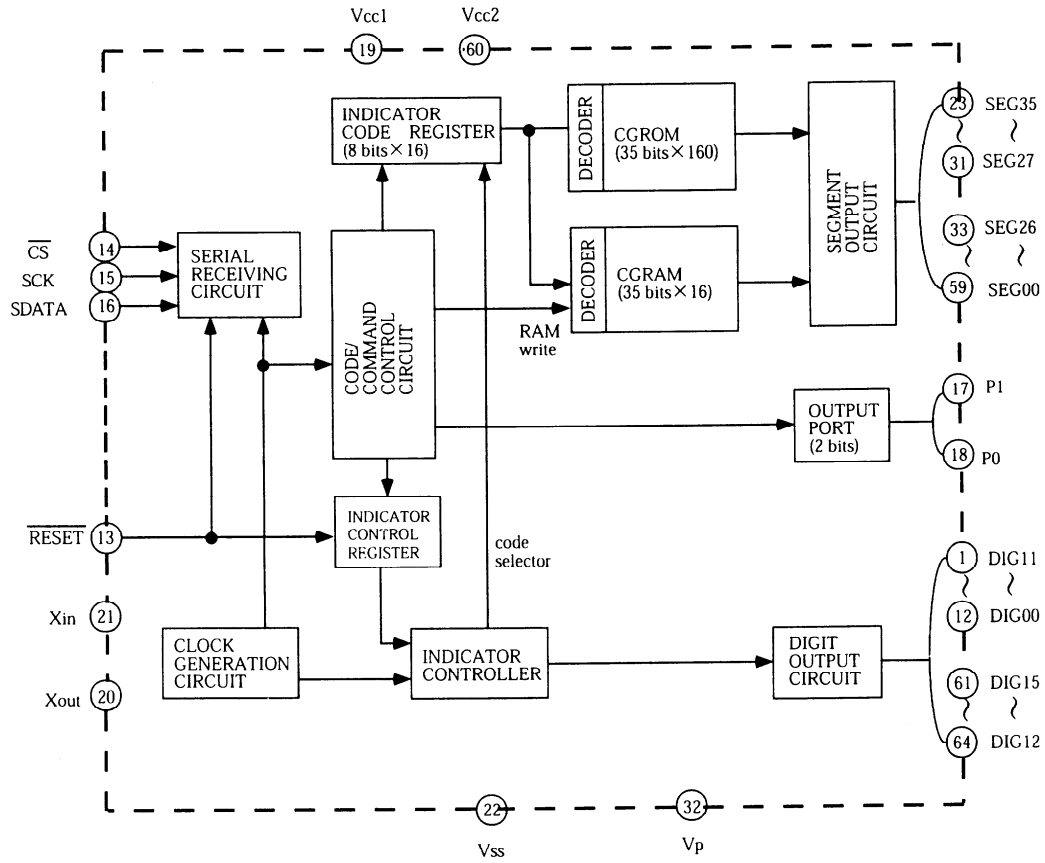

M5M5256FP-L(RAM)

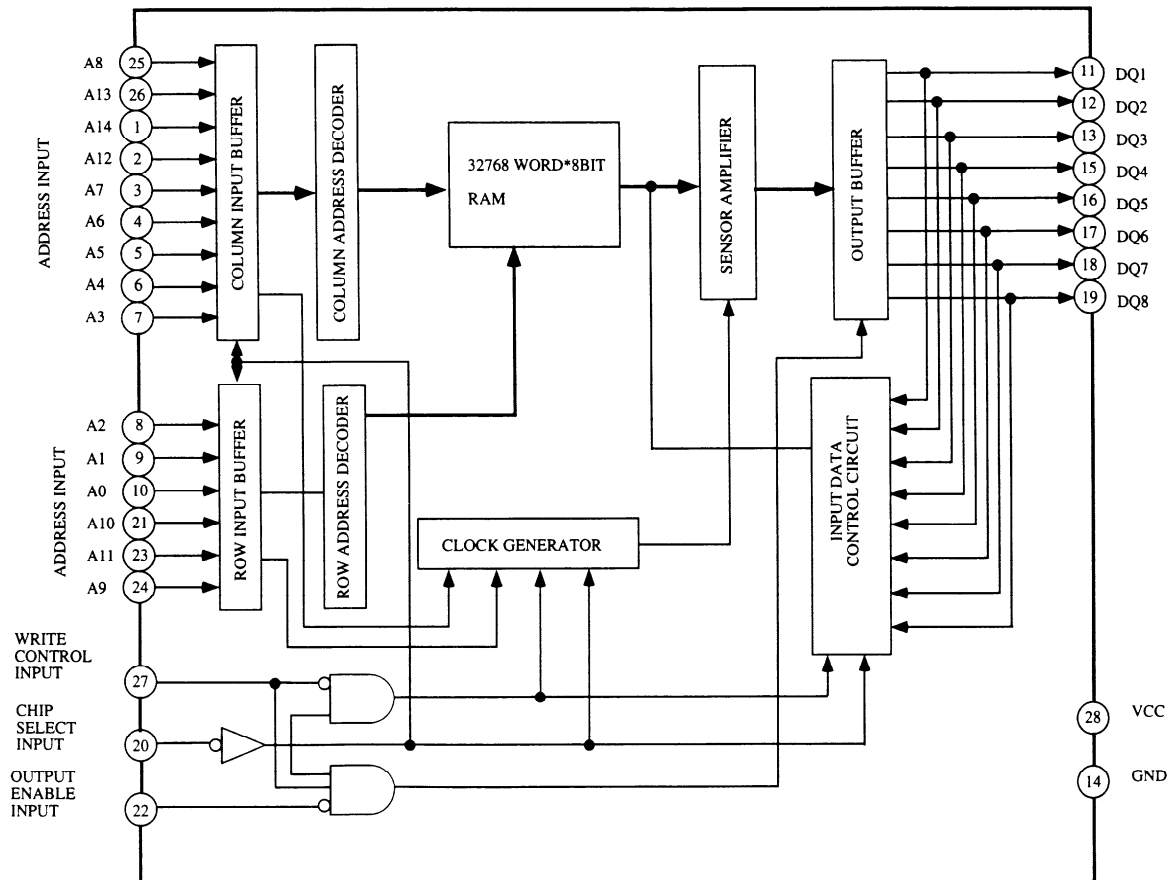

AK4321-VS(D/A Converter)

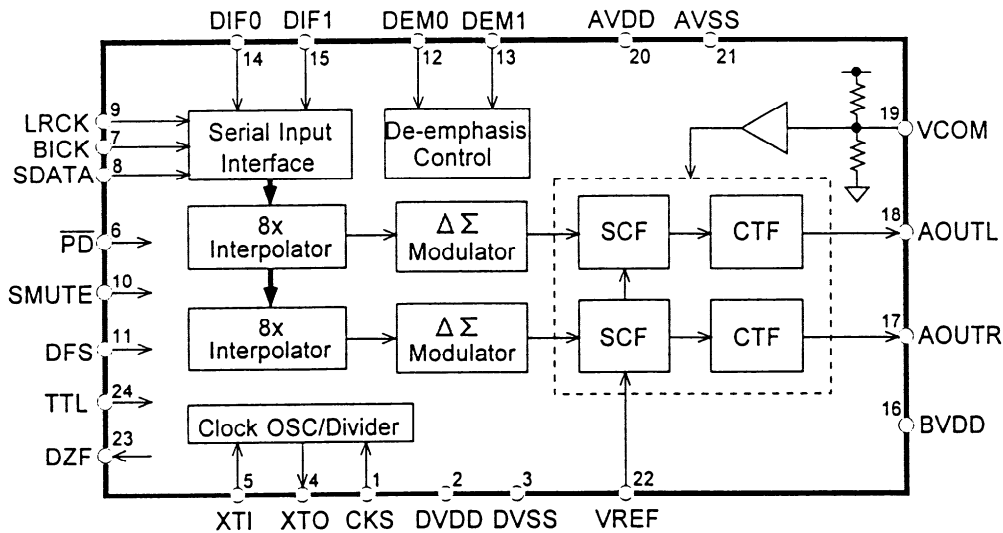

Pin No.	Symbol	I/O	Function
1	CKS	I	Clock Select Pin
2	DVDD	—	Digital Power Supply Pin
3	DVSS	—	Digital Ground Pin
4	XTO		Crystal Oscillator Output Pin
5	XTI	O	Crystal Oscillator Input Pin
6	PD	I	Power-Down Pin
7	BICK	I	Serial Bit Clock Pin
8	SDATA	I	Serial Data Input Pin
9	LRCK	I	L/R Clock Pin
10	SMUTE	I	Soft Muting Pin
11	DFS	I	Double Speed Sampling Mode Pin
12	DEM0	I	De-emphasis Mode Pins
13	DEM1	I	
14	DIF0	I	Input Format Pins
15	DIF1	I	
16	BVDD	I	Power Supply Pin
17	AOUTR	O	R ch. Analog Output Pin
18	AOUTL	O	L ch. Analog Output Pin
19	VCOM	O	Common Voltage Pin
20	AVDD	—	Analog Power Supply Pin
21	AVSS	—	Analog Ground Pin
22	VREF	I	Reference Voltage Input Pin
23	DZF	O	Zero-cross Input Detect Pin
24	TTL	I	I/F Level Select Pin

TC74HC4040(12-Stage Binary Counter)

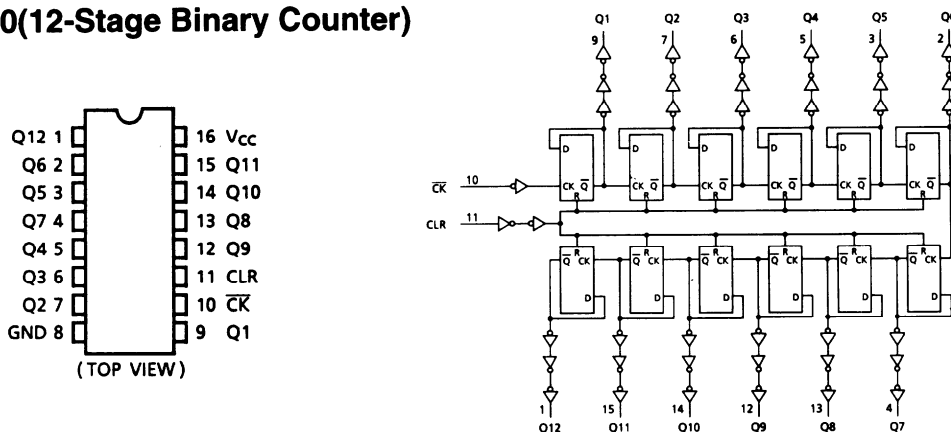

AK4520A-VS(A/D and D/A Converter)

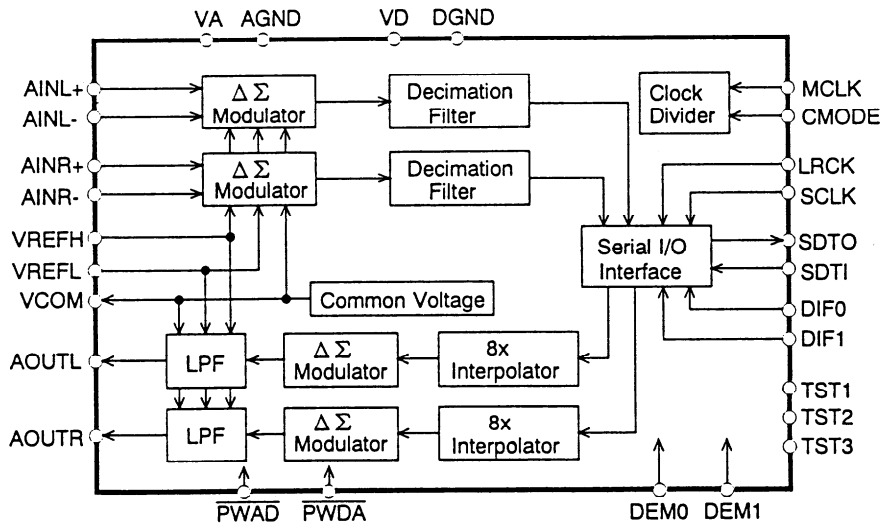

No.	Symbol	I/O	Function
1	VREFH	I	Positive Voltage Reference Input Pin, V A
2	VREFL	I	Negative Voltage Reference Input Pin, A G N D
3	A IN R +	I	Rch Analog Positive Input pin
4	A IN R -	I	Rch Analog Negative Input pin
5	A IN L +	I	Lch Analog Positive Input pin
6	A IN L -	I	Lch Analog Negative Input pin
7	V A	-	Analog Power Supply Pin
8	A G N D	-	Analog Ground Pin
9	D I F 0	I	Audio Data Interface Format Pin
10	D I F 1	I	Audio Data Interface Format Pin
11	L R C K	I	Input/Output Channel Clock Pin
12	S C L K	I	Audio Serial Data Clock Pin
13	S D T I	I	Audio Serial Data Input Pin
14	S D T O	O	Audio Serial Data Output Pin
15	M C L K	I	Master Clock Input Pin
16	D E M 0	I	De-emphasis Frequency Select Pin
17	D E M 1	I	De-emphasis Frequency Select Pin
18	T S T 3	I / O	Test Pins (Pull down pins)
19	T S T 2	I / O	
20	T S T 1	I	
21	V D	-	Digital Power Supply Pin
22	D G N D	-	Digital Ground Pin
23	P W D A	I	D A C Power-Down Mode Pin
24	P W A D	I	A D C Power-Down Mode Pin
25	C M O D E	I	Master Clock Select Pin " H ":384fs, " L ":256fs
26	A O U T L	O	Lch Analog Output Pin
27	A O U T R	O	Rch Analog Output Pin
28	V C O M	O	Common Voltage Output Pin, V A / 2

74HC04(Hex Inverter)

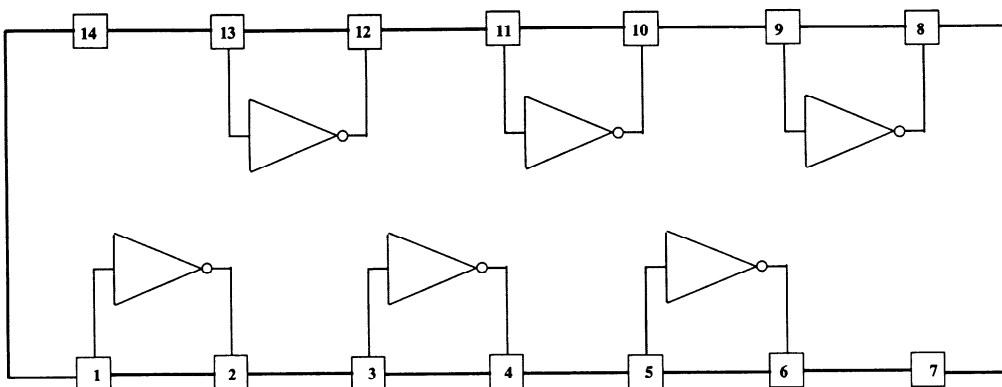

LM7001 (PLL Synthesizer and Controller)

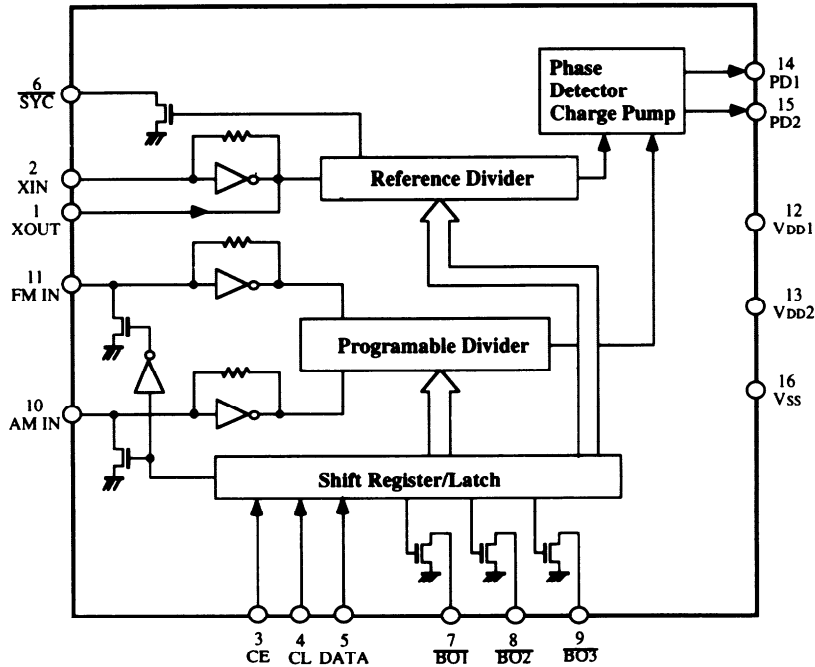

BU1922(RDS Decoder)

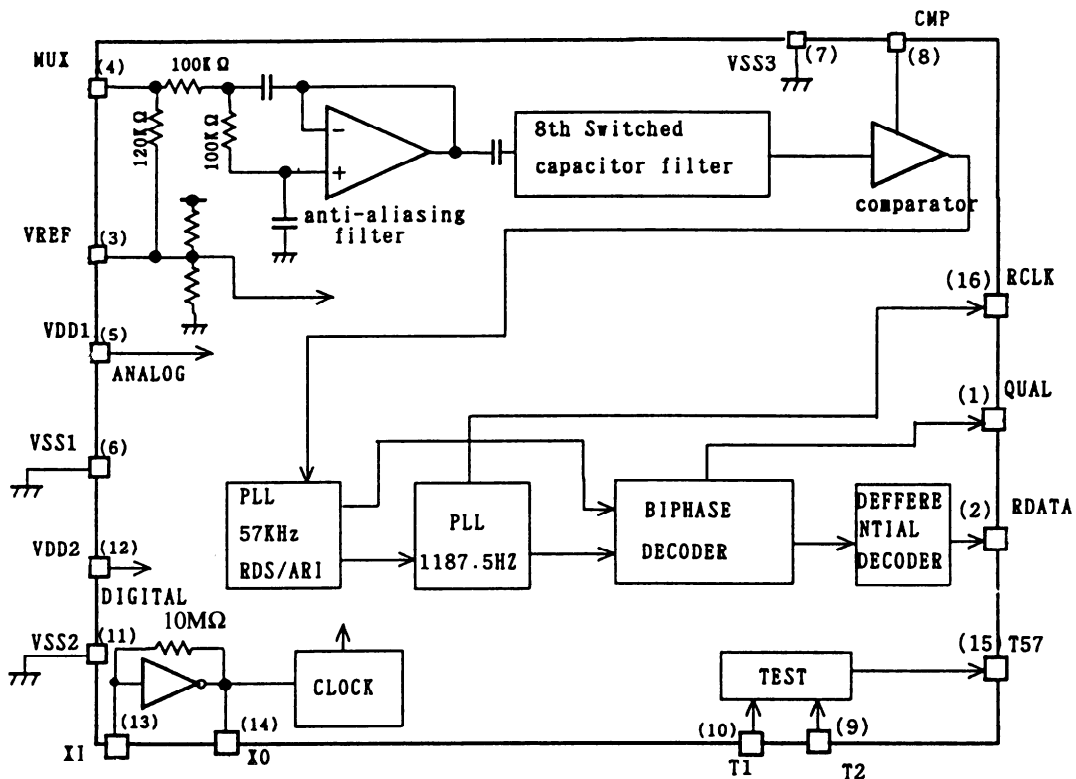

PRINTED CIRCUIT BOARD-PARTS LIST

MAIN CIRCUIT PC BOARD(NAAR-6095-1A/1B/1C/1D)

CIRCUIT NO.	PART NO.	DESCRIPTION	CIRCUIT NO.	PART NO.	DESCRIPTION
					Capacitors
			C305,C306	354721019	100 μ F,6.3V,Elect.
			C307,C308	374726824	6800pF \pm 5%,50V,Plastic
			C309,C310	374721824	1800pF \pm 5%,50V,Plastic
			C311,C312	354741009	10 μ F,16V,Elect.
			C341,C342	354741009	10 μ F,16V,Elect.
			C363,C364	354742209	22 μ F,16V,Elect.
			C373,C374	354741009	10 μ F,16V,Elect.
			C379-C382	374721044	0.1 μ F \pm 5%,50V,Plastic
			C383,C384	374721534	0.015 μ F \pm 5%,50V,Plastic
			C385,C386	354741009	10 μ F,16V,Elect.
			C702	375524744	0.47 μ F \pm 5%,50V,Plastic
			C703	3000076 or 3000078	EECS5R5T104 or DX-5R5L104
			C704,C705	354721019	100 μ F,6.3V,Elect.
			C706	354741009	10 μ F,16V,Elect.
			C707	354780109	1 μ F,50V,Elect.
			C708	354721019	100 μ F,6.3V,Elect.
			C921,C922	3504310 or 3504314	4700 μ F,35V,Elect. or 4700 μ F,35V,Elect.
			C926	354754719	470 μ F,25V,Elect.
			C928	354741009	10 μ F,16V,Elect.
			C931	354782219	220 μ F,50V,Elect.
			C932	354762219	220 μ F,35V,Elect.
			C933	354754729 8	4700 μ F,25V,Elect.
			C934,C949	354751029 8	1000 μ F,25V,Elect.
			C937,C938	354741009	10 μ F,16V,Elect.
			C941,C942	354741009	10 μ F,16V,Elect.
					Resistors
			R923,R929	443522204	22 Ω \pm 5%,1/2W, Metal oxide
			R924	443523314	330 Ω \pm 5%,1/2W, Metal oxide
			R925,R931	443621204	12 Ω \pm 5%,1W, Metal oxide
			R932	443524704	47 Ω \pm 5%,1/2W, Metal oxide
			R933,R936	453630684	6.8 Ω \pm 5%,1W, Metal
			R934	443526804	68 Ω \pm 5%,1/2W, Metal oxide
			R935	453530104	1 Ω \pm 5%,1/2W, Metal
					Sockets
			JL602a	25051090	NSCT-6P877
			JL691a	25051107	NSCT-3P894
			JL701a	25051847, 25050980 or 25051306	NSCT-40P1634, NSCT-40P767 or NSCT-40P1095
			JL922a	25051112	NSCT-8P899
			JL971a,JL972a	25051090	NSCT-6P877
					Terminals
			P301-P303	25045458 or 25045300	NPJ-6PDBL279 or NPJ-6PDBL159
			P304	25045460 or 25045303	NPJ-4PDBL281 or NPJ-4PDBL162
					Plugs
			P102a	25055652	NPLG-14P608 <D/T/W/A/K>
			P245a	25055653	NPLG-16P609 <P>
			JL391b	25055133	NPLG-3P117
			P401a	25055628	NPLG-7P590
			P402a,P401A	25055704 25055808	NPLG-8P660 NPLG-19P764
					ICs
Q1301,Q1371	22240293 or	NJM4558L-D or			
Q303	22240247	BA15218N			
Q301	22240191	NJM4565D-D			
Q304	22240800	TC9164AN			
Q305	22240829	TC9274N-008			
Q371,Q372	22240293 or 22240247	NJM4558L-D or BA15218N			
Q701	22241121	μ PD78016FGC-			
Q702	22240239	TA7291S			
Q922	222780565JRC	78M56(NJM78M56FA)			
Q923	222780125	78M12HF			
Q924	222790125	79M12HF			
Q925	222780075	78M07HF			
Q926	222790075	79M07HF			
					Transistors
Q1372	2211945	2SK246-GR			
Q1391	2213510 or 2214350	DTA114ES or RN2202			
Q1392	2212600	DTA124ES			
Q1393	2213816 or 2212356	2SD1450-T or 2SD1302-T			
Q373,Q374	2211945	2SK246-GR			
Q703	221282 or 2213560	DTC144ES or RN1204			
Q704	2213510 or 2214350	DTA114ES or RN2202			
Q927	2211255	2SC1815-GR			
Q928	2213640 or 2214660	DTC123JS or RN1205			
Q929	2211455	2SA1015-GR			
					Diodes
D1301,D1302	223163 or	1SS133 or			
D1371	223205	1SS270A			
D371,D372	223163 or	1SS133 or			
D701-D704	223205	1SS270A			
D705	224470562	MTZJ5.6B			
D706	224470623	MTZJ6.2C			
D707,D708	223163 or	1SS133 or			
D926-D929	223205	1SS270A			
D921	22380022F, 22380271F or 22380285F	RBV402, D3SBA20 or RS403M			
D922-D925	22380260,	RL1N4003,			
D930-D933	22380032 or 22380035	1SR139-100 or GP104003E			
D934	224473604	MTZJ36D			
					Coil
L701	233454K220	NCH-1452 220K			
					Oscillator
X701	3010239	CST10.0MTW			
					Capacitors
C1301-C1304	354741009	10 μ F,16V,Elect.			
C1306	374721034	0.01 μ F \pm 5%,50V,Plastic			
C1307,C1372	354741009	10 μ F,16V,Elect.			
C1375,C1376	374721044	0.1 μ F \pm 5%,50V,Plastic			
C303,C304	354741009	10 μ F,16V,Elect.			

CAUTION: Replacement of the transistor of mark *, if necessary, must be made from the same beta group (HFE) as the original type.

CIRCUIT NO.	PART NO.	DESCRIPTION
	Heatsinks	
Q925a	27160227	RAD-076
Q922a	27160209	RAD-67
	Screws	
Q922b,Q925b	838430107	3TTP+10S(BC)

**HEADPHONE TERMINAL PC BOARD
(NAETC-6104-1A/1B/1C)**

CIRCUIT NO.	PART NO.	DESCRIPTION
JL571a	25051107	NSCT-3P894,Socket
P571	25045255	YKB26-5009,Headphone terminal

**FRONT/CENTER POWER AMP. PC BOARD
(NAAF-6108-1A/1B/1C/1D/1E/1F)**

CIRCUIT NO.	PART NO.	DESCRIPTION
	Transistors	
Q1501-Q1503	2211733 or	2SC1845-E or
Q1515	2211732	2SC1845-F
Q1504	2213284 or	2SC1740S-R or
	2212115	2SC2458-GR
Q1505,Q1506	2211354 or	2SA949-Y or
Q1508	2211353	2SA949-O
Q1507,Q1509	2211634 or	2SC2229-Y
	2211633	2SC2229-O
Q1511	2203010	2SC5171
Q1512	2203000	2SA1930
Q1513	2201653,	* 2SC3856-O,
Q525,Q526	2201655,	* 2SC3856-P,
	2201654,	* 2SC3856-Y,
	2202842 or	* 2SC5242-R or
	2202843	* 2SC5242-O
Q1514	2201663,	* 2SA1492-O,
Q527,Q528	2201665,	* 2SA1492-P,
	2201664,	* 2SA1492-Y,
	2202832 or	* 2SA1962-R or
	2202833	* 2SA1962-O
Q1516	2212654 or	2SC3421-Y or
Q531,Q532	2212653	2SC3421-O
Q501-Q506	2211733 or	2SC1845-E or
Q529,Q530	2211732	2SC1845-F
Q507,Q508	2213284 or	2SC1740S-R or
	2212115	2SC2458-GR
Q509-Q512	2211354 or	2SA949-Y
Q515,Q516	2211353	2SA949-O
Q513,Q514	2211634 or	2SC2229-Y
Q517,Q518	2211633	2SC2229-O
Q521,Q522	2203010	2SC5171
Q523,Q524	2203000	2SA1930
Q581	2211793 or	2SA992-E
	2211792	2SA992-F
Q582,Q583	2213284 or	2SC1740S-R or
	2212115	2SC2458-GR
Q584,Q585	2213650	DTD113ZS
	Diodes	
D581	224470512	MTZJ5.1B
D582,D583	223163 or	1SS133 or
	223205	1SS270A

CIRCUIT NO.	PART NO.	DESCRIPTION
	Diodes	
D961	22380070,	D5SBA60,
	22380038 or	RBV602 or
	22380274	RS603M, Diode
D962,D963	22380260,	RL1N4003,
	22380032 or	1SR139-100 or
	22380035	GP104003E
	Coils	
L1501	231176S	S-1.3C <P/W/T/A/K>
L501,L502	231176S	S-1.3C <P/W/T/A/K>

CIRCUIT NO.	PART NO.	DESCRIPTION
	Capacitors	
C1501	354742209	22 μ F, 16V, Elect.
C1504	354742219	220 μ F, 16V, Elect.
C1505	354744709	47 μ F, 16V, Elect.
*C1509,C1511	354781009	10 μ F, 50V, Elect.
C1512	374721044	0.1 μ F \pm 5%, 50V, Plastic
C1515,C1516	354772209S	22 μ F, 63V, Elect.
C501,C502	354742209	22 μ F, 16V, Elect.
C507,C508	354742219	220 μ F, 16V, Elect.
C509,C510	354744709	47 μ F, 16V, Elect.
C517,C518	354781009	10 μ F, 50V, Elect.
C521,C522	354781009	10 μ F, 50V, Elect.
C523,C524	374721044	0.1 μ F \pm 5%, 50V, Plastic
C529,C530	354772209S	22 μ F, 63V, Elect.
C541,C542	374721034	0.01 μ F \pm 5%, 50V, Plastic
		<P/T/W/A/K>
C582	354742219	220 μ F, 16V, Elect.
C962,C963	374731044	0.1 μ F \pm 5%, 50V, Plastic
C964,C965	3504309 or	12000 μ F, 63V or
	3504313	12000 μ F, 63V, Elect.
C966,C967	354774719S	470 μ F, 63V, Elect.
	Resistors	
R1512	443526804	Δ 68 Ω \pm 5%, 1/2W, Metal oxide
R1513,R1514	443525604	Δ 56 Ω \pm 5%, 1/2W, Metal oxide
R1515,R1516	443526804	Δ 68 Ω \pm 5%, 1/2W, Metal oxide
R1519	5210288	N06HR2.2KBE, Trimming
R1522	443521514	150 Ω \pm 5%, 1/2W, Metal oxide
R1523,R1524	453530224	2.2 Ω \pm 5%, 1/2W, Metal
R1525	4000132	RGC55 0.22, Thermistor
R1528	453630824	8.2 Ω \pm 5%, 1W, Metal
R523,R524	443526804	Δ 68 Ω \pm 5%, 1/2W, Metal oxide
R525-R528	443525604	Δ 56 Ω \pm 5%, 1/2W, Metal oxide
R529-R532	443526804	Δ 68 Ω \pm 5%, 1/2W, Metal oxide
R537,R538	5210288	N06HR2.2KBE, Trimming
R543,R544	443521514	150 Ω \pm 5%, 1/2W, Metal oxide
R545-R548	453530224	2.2 Ω \pm 5%, 1/2W, Metal
R549,R550	4000132	RGC55 0.22, Thermistor
R555,R556	453630824	8.2 Ω \pm 5%, 1W, Metal
R571,R572	443623914	390 Ω \pm 5%, 1W, Metal oxide
R962,R963	453530224	Δ 2.2 Ω \pm 5%, 1/2W, Metal
	Sockets	
JL501a,JL501b	25051109	NSCT-5P896
JL502a,JL502b	25051088	NSCT-4P875
JL501A,JL921b	25051110	NSCT-6P897
JL551a	25051109	NSCT-5P896
JL571b	25050267	NSCT-3P95

NOTE: THE COMPONENTS IDENTIFIED BY MARK Δ ARE CRITICAL FOR RISK OF FIRE AND ELECTRIC SHOCK. REPLACE ONLY WITH PART NUMBER SPECIFIED.

CIRCUIT NO.	PART NO.	DESCRIPTION
	Plugs	
JL602b	25055627	NPLG-6P589
JL971b	25055627	NPLG-6P589
P1501	25055038	NPLG-2P29
P501,P502	25055038	NPLG-2P29
P551a	25055135	NPLG-5P119
	Relaies	
RL581,RL582	25065517 or 25065510	NRL-2P5A-DC24-098 or NRL-2P5A-DC24-095

SECONDARY CIRCUIT PC BOARD (NAETC-6110-1A/1B/1C/1D/1E/1F)

CIRCUIT NO.	PART NO.	DESCRIPTION
F915,F916	252166	Δ 6.3A-UL/T-237,Fuse <D>
	252079	Δ 6.3A-SE-EAK,Fuse <P/T/W/A/K>
F915a,F916a	25050065	Δ YSH403T,Fuseholder
JL921a	25051110	NSCT-6P897,Socket
JL922b	25050285	NSCT-8P113,Socket
R941,R942	453532294	0.22 Ω \pm 5%,1/2W, Metal resistor

PRIMARY CIRCUIT PC BOARD (NAPS-6113-1A/1B/1C/1D/1E/1F)

CIRCUIT NO.	PART NO.	DESCRIPTION
	Transistor	
Q951	2213284	2SC1740S-R
	Diodes	
D951-D954	22380035	GP104003E
	22380032 or	1SR139-100 or
	22380260,	RL1N4003,
D955	223163 or	1SS133 or
	223205	1SS270A
	Transformer	
T902	2300670A	Δ NPT-1111D <D>
	2300671A	Δ NPT-1111P <P/T/A>
	2300672	Δ NPT-1111DG <W/K>
	Capcitors	
C901	3500191	Δ DE7150F-103M
C952	354742219	220 μ F,16V,Elect.
	Resistors	
R901	431533355	Δ 3.3M Ω ,1/2W,Solid <D>
R951	453530824	8.2 Ω \pm 5%,1/2W, Metal
	Fuseholders	
F901a	25050065	Δ YSH403T <D/W>
F902a	25050065	Δ YSH403T <PT/W/A/K>
F903a	25050065	Δ YSH403T <P>
	Fuses	
F901	252198	Δ 8A-UL <D/W>
F902	252077	Δ 4A-SE-EAK <P/T/W/A/K>
F903	252075	Δ 2.5A-SE-EAK <P>
	252074	Δ 2A-SE-EAK <T/A>
	Sockets	
JL942a	25051087	NSCT-3P874
	Plug	
P901a	25055675	Δ NPLG-2P631
	Switch	
S901	25065437	Δ NSS-22157P <W>

CIRCUIT NO.	PART NO.	DESCRIPTION
	Relay	
RL901	25065515 or	Δ NRL-1P5A-DC12-096 or
	25065508	Δ NRL-1P10A-DC12-093 <P/T/W/A/K>
	25065516 or	Δ NRL-1P10A-DC12-097 or
	25065248	Δ NRL-1P15A-DC12-29 <D>

FRONT/CENTER SPEAKER TERMINAL PC BOARD (NAETC-6115-1A/1B/1C/1D/1E/1F)

CIRCUIT NO.	PART NO.	DESCRIPTION
C1541	374721034	0.01 μ F \pm 5%,50V,Plastic capacitor <P/T/W/A/K>
C541,C542	374721034	0.01 μ F \pm 5%,50V,Plastic capacitor <P/T/W/A/K>
JL503b	25051110	NSCT-6P897,Socket
P541	25060246	NTM-4PDMN166,Terminal
P542	25060114	NTM-2PDMLO48,Terminal <D>
	25060247	NTM-2PDMN167,Terminal <P/T/W/A/K>

AC OUTLET TERMINAL PC BOARD(NAETC-6116-1B/1C/1D)

CIRCUIT NO.	PART NO.	DESCRIPTION
P904	25051125	Δ NSCT-4P912,Terminal <P/T/W>

POWER SWITCH PC BOARD(NASW-6117-1B/1C/1D/1E/1F) 230V and Worldwide models

CIRCUIT NO.	PART NO.	DESCRIPTION
C931	3500191	Δ DE7150F-103M, Capacitor IS
C931a	27301216	Δ Cover,capacitor
S931	25035550	Δ NPS-111-L512P,Push switch

AC OUTLET TERMINAL PC BOARD(NAETC-6118-1A)

CIRCUIT NO.	PART NO.	DESCRIPTION
P902	25051639	Δ NSCT-4P1426,Terminal <D>

MR/RI TERMINAL PC BOARD(NAETC-6096-1A/1B/1C/1D)

CIRCUIT NO.	PART NO.	DESCRIPTION
	Transistors	
Q981,Q982	221282 or 2213560	DTC144ES or RN1204
Q983	24120043	ON3131 <D>
Q984	2213510 or 2214350	DTA114ES or RN2202 <D>
Q985	2213284 or 2212115	2SC1740S-R or 2SC2458-GR <D>
	Diodes	
D981,D982	223163 or 223205	1SS133 or 1SS270A <P/T/W/K/A>
D983	223163 or 223205	1SS133 or 1SS270A
D984	223163 or 223205	1SS133 or 1SS270A <D>
	Capacitors	
C981	374724724	4700pF \pm 5%,50V,Plastic
C982	353741009	10 μ F,16V,Elect.
C983	353741009	10 μ F,16V,Elect. <D>
	Plugs	
JL942b	25055624	NPLG-3P586
JL972b	25055627	NPLG-6P589

CIRCUIT NO.	PART NO.	DESCRIPTION	CIRCUIT NO.	PART NO.	DESCRIPTION
JL242a	25051093	NSCT-9P880	R623,R624	443526804	68Ω ± 5%,1/2W, Metal oxide
	Socket		R625-R628	443525604	56Ω ± 5%,1/2W, Metal oxide
P981	25045293	HSJ1003-01-012 <P/T/W/A/K>	R629-R932	443526804	68Ω ± 5%,1/2W, Metal oxide
	Terminals		R637,R638	5210288	N06HR2.2KBE,Trimming
P982	25045433	HSJ1003-01-013 <D>	R643,C644	443521514	150Ω ± 5%,1/2W, Metal oxide
	25045330 or	NPJ-2PDBL184 or	R645-R648	453530224	2.2Ω ± 5%,1/2W, Metal
	25045481	NPJ-2PDBL299	R649,R650	4000131	RGC22-0.22 OHMK,Metal plate

SURROUND POWER AMPLIFIER PC BOARD (NAAF-6097-1A/1B/1C/1D)

CIRCUIT NO. PART NO. DESCRIPTION

CIRCUIT NO.	PART NO.	DESCRIPTION
	Transistors	
Q601-Q606	2211733 or 2211732	2SC1845-E 2SC1845-F
Q607,Q608	2213284 or 2212115	2SC1740S-R or 2SC2458-GR
Q609-Q612	2211354 or 2211353	2SA949-Y 2SA949-O
Q613,Q614	2211634 or 2211633	2SC2229-Y 2SC2229-O
Q615,Q616	2211354 or 2211353	2SA949-Y 2SA949-O
Q617,Q618	2211634 or 2211633	2SC2229-Y 2SC2229-O
Q619,Q620	2213284 or 2212115	2SC1740S-R or 2SC2458-GR
Q621,Q622	2203010	2SC5171
Q623,Q624	2203000	2SA1930
Q625,Q626	2202922, 2202923, 2202373, 2202375 or 2202374	* 2SC5196-R, * 2SC5196-O, * 2SC4466-O, * 2SC4466-P or * 2SC4466-Y
Q627,Q628	2202912, 2202913, 2202363, 2202365 or 2202364	* 2SA1939-R, * 2SA1939-O, * 2SA1693-O, * 2SA1693-P or * 2SA1693-Y
Q629,Q630	2211733 or 2211732	2SC1845-E or 2SC1845-F
Q681,Q682	2213650	DTD113ZS
	Diodes	
D601,D602	22380260, 22380032 or 22380035	RL1N4003, 1SR139-100 or GP104003E
D681,D682	223163 or	1SS133 or
D681,D682	223205	1SS270A
	Coil	
L601,L602	231176S	S-1.3C <P/T/W/A>
	Capacitors	
C601,C602	354742209	22 μ F,16V,Elect.
C607,C608	354742219	220 μ F,16V,Elect.
C609,C610	354744709	47 μ F,16V,Elect.
C617,C618	354781009	10 μ F,50V,Elect.
C623,C624	374721044	0.1 μ F ± 5%,50V,Plastic
C629,C630	354784719S	470 μ F,50V,Elect.
C631	354781009	10 μ F,50V,Elect.
C632-C634	354781019	100 μ F,50V,Elect.

CIRCUIT NO.	PART NO.	DESCRIPTION
R675,R676	453532294	0.22Ω ± 5%,1/2W, Metal
	Resistors	
RL681,RL682	25065517 or	NRL-2P5A-DC24-098 or
RL681,RL682	25065510	NRL-2P5A-DC24-095
	Sockets	
JL601a	25051110	NSCT-6P897
JL601A	25051091	NSCT-7P878
JL691b	25050267	NSCT-3P95
	Plugs	
P601,P602	25055038	NPLG-2P29
P611a	25055133	NPLG-3P117

CIRCUIT NO. PART NO. DESCRIPTION

CIRCUIT NO.	PART NO.	DESCRIPTION
C641-C644	374721034	0.01 μ F ± 5%,50V, Plastic capacitor<P/T/W/A/K>
JL601b	25051110	NSCT-6P897,Socket
P641	25060224 or 25060158	NTM-8PDM146 or NTM-8PDM1084,Terminal

SPEAKER TERMINAL PC BOARD(NAETC-6098-1A/1B/1C/1D)

CIRCUIT NO.	PART NO.	DESCRIPTION
C1414	374723344	0.33 μ F ± 5%,50V,Plastic capacitor
JL401b	25051087	NSCT-3P874,Socket
JL402a	25051093	NSCT-9P880,Socket
JL603b	25055628	NPLG-7P590,Plug
P1401	25045458 or 25045300	NPJ-6PDBL279 or NPJ-6PDBL159,Terminal
P1402	25045298 or 25045456	NPJ-2PDBL157 or NPJ-2PDBL277,Terminal
P1404	25045459 or 25045302	NPJ-1PDBL260 or NPJ-1PDBL161,Terminal

PREOUT/MAIN IN TERMINAL PC BOARD(NAETC-6102-1A/1B/1C)

CIRCUIT NO.	PART NO.	DESCRIPTION
C395,C396	374721534	0.015 μ F ± 5%,50V,Plastic capacitor
JL391a	25051091	NSCT-7P878,Socket
R395,R396	5104356	N14RLC100KWT20Z,Variable resistor

TONE VOLUME PC BOARD(NAAF-6103-1A/1B/1C)

CIRCUIT NO.	PART NO.	DESCRIPTION
C395,C396	374721534	0.015 μ F ± 5%,50V,Plastic capacitor
JL391a	25051091	NSCT-7P878,Socket
R395,R396	5104356	N14RLC100KWT20Z,Variable resistor

NOTE: D : 120V model only
P : European model only
T : Asian model only
W : Worldwide model only
K : Korean model only
A : Australian model only

A B C D E F G

BLOCK DIAGRAM

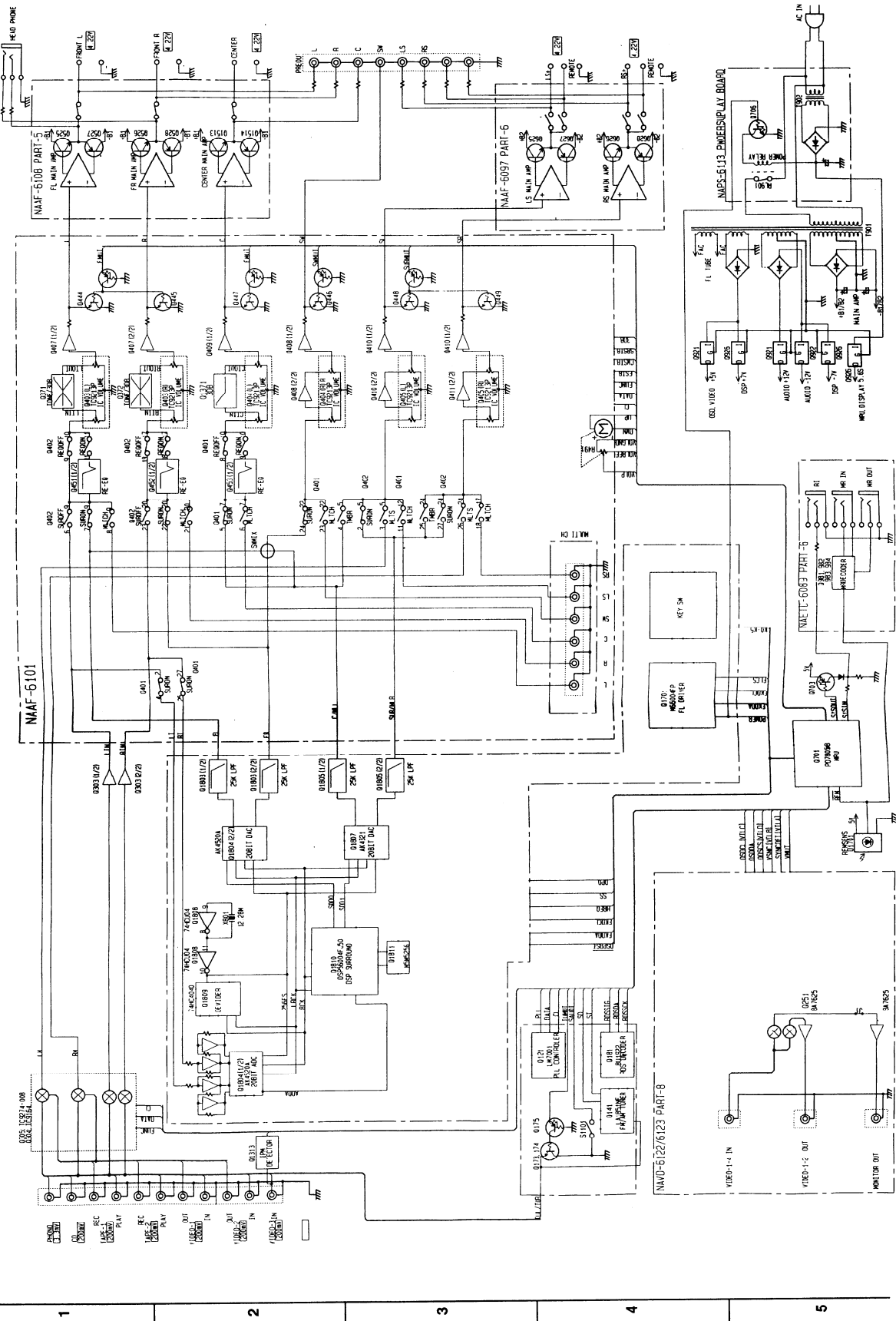

A B C D E F G

SCHEMATIC DIAGRAM

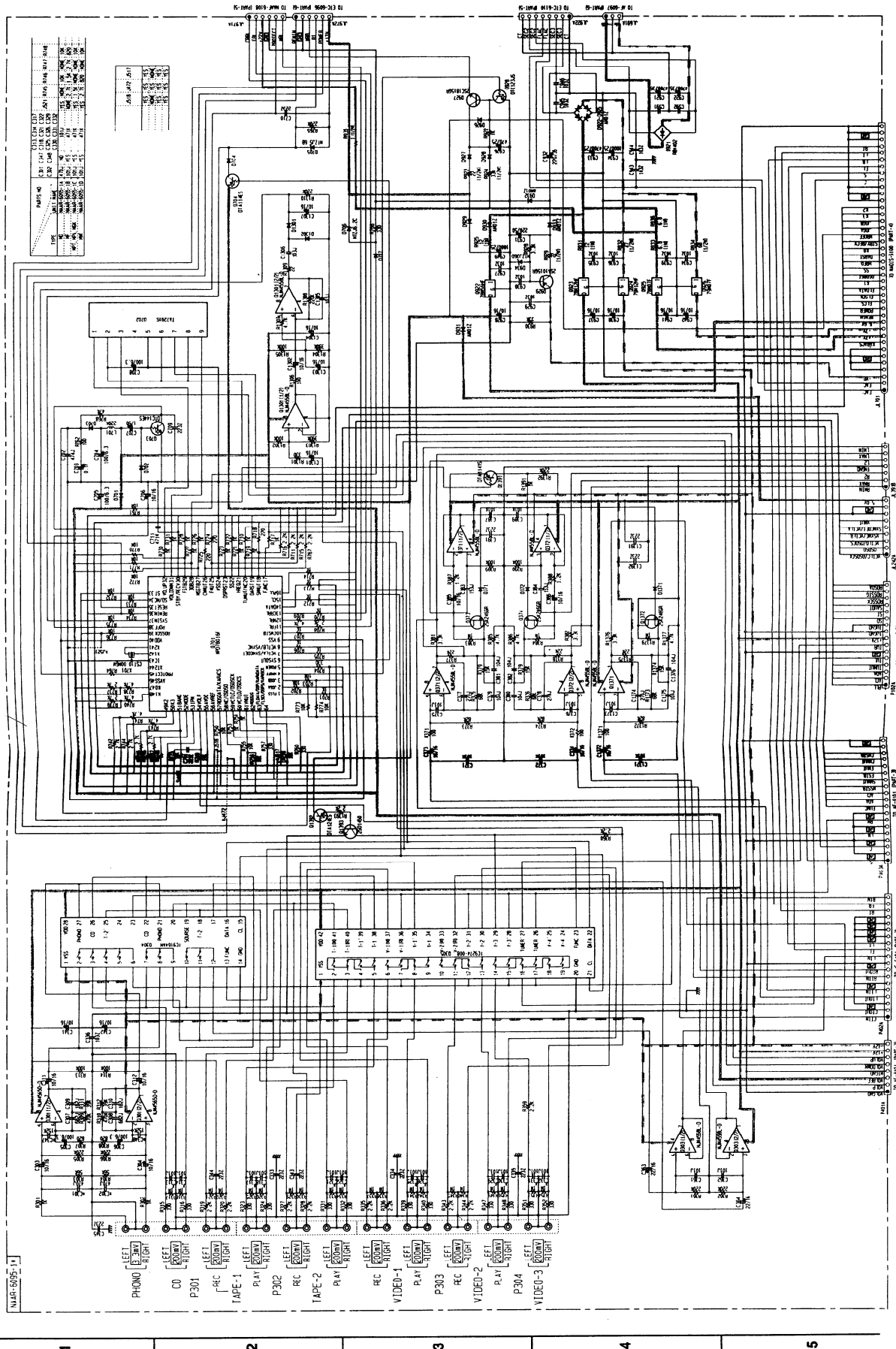

PRINTED CIRCUIT BOARD- PARTS LIST

ELECTRO VOLUME CIRCUIT PC BOARD(NAAF-6101-1A/1B/1C)

CIRCUIT NO.	PART NO.	DESCRIPTION
ICs		
Q401	22240798	TC9162AN
Q402	22240799	TC9161AN
Q403-Q405	22240266	TC9213P
Q406-Q411	22240293 or	NJM4558L-D or
Q451-Q453	22240247	BA15218N
Transistors		
Q441-Q443	2213510 or 2214350	DTA114ES or RN2202
Q444-Q449	2213631 or 2213632	RN1241-A or RN1241-B
Diodes		
D441-D443	223163 or 223205	1SS133 or 1SS270A
Capacitors		
C404-C410	354741009	10 μ F,16V,Elect.
C411-C413	354780229	2.2 μ F,50V,Elect.
C417	374721034	0.01 μ F \pm 5%,50V,Plastic <D>
C420-C422	354741009	10 μ F,16V,Elect.
C423-C428	354780229	2.2 μ F,50V,Elect.
C435-C440	354744709	47 μ F,16V,Elect.
C441-C443	354741009	10 μ F,16V,Elect.
C451-C453	354741009	10 μ F,16V,Elect.
C454-C459	374721224	1200pF \pm 5%,50V,Plastic
C460-C462	354741009	10 μ F,16V,Elect.
C463-C465	374722224	2200pF \pm 5%,50V,Plastic
C471-C473	354741009	10 μ F,16V,Elect.
C481,C482	354741009	10 μ F,16V,Elect.
Resistors		
R491	5146066	N16RGL20KB25F,Variable
Sockets		
JL401a	25051087	NSCT-3P874
JL402b	25051093	NSCT-9P880
P401b	25051233	NSCT-8P1023
P402b	25051530	NSCT-19P1317
P403b	25051530	NSCT-19P1317
P551	2009990466UL	NSAS-10P0620
P611	2009990449UL	NSAS-6P0600

A B C D E F G

SCHEMATIC DIAGRAM

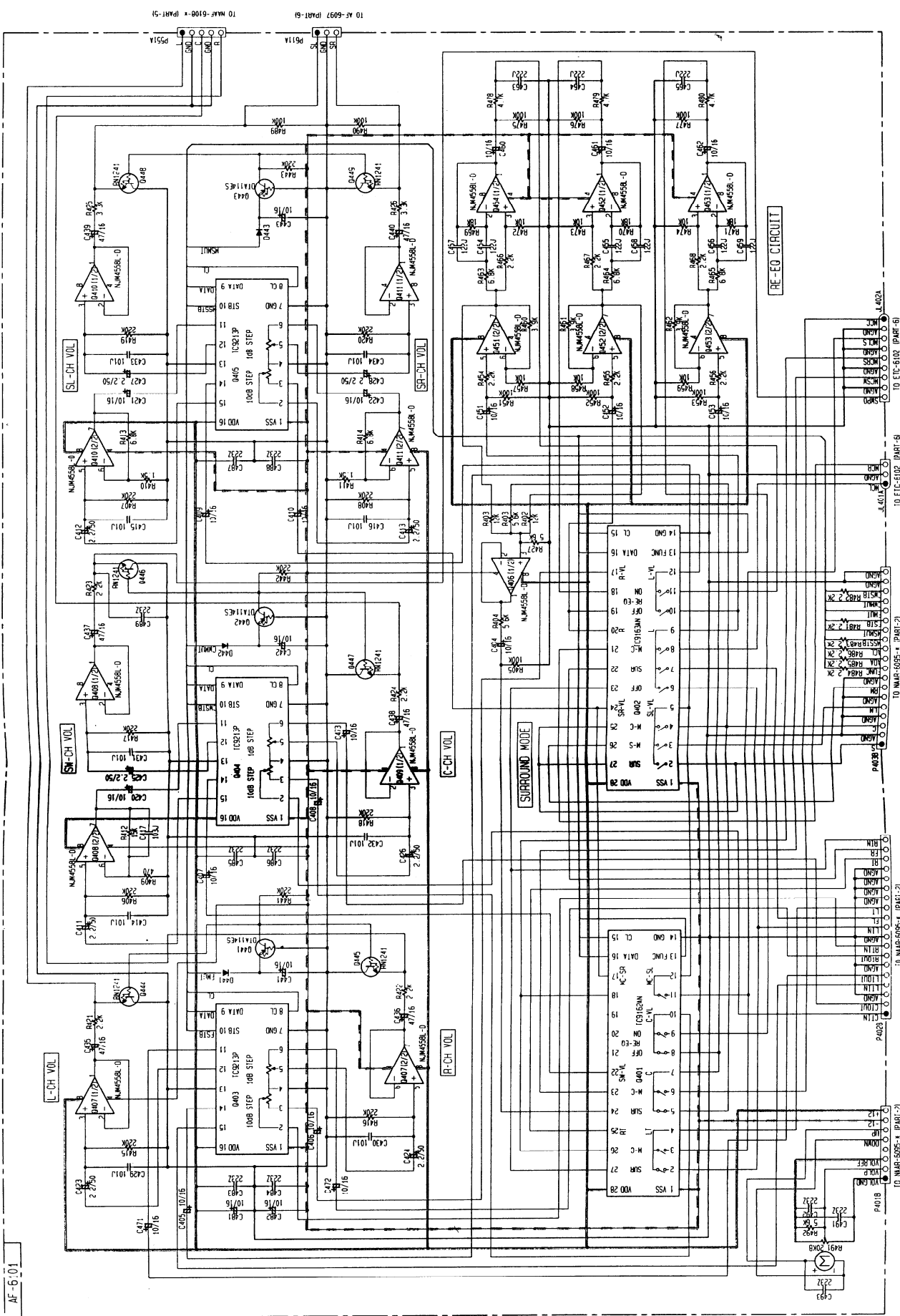

AF-6-01

1

2

3

4

5

PRINTED CIRCUIT BOARD -PARTS LIST

DISPLAY CIRCUIT PC BOARD (NADIS-6100-1A/1B/1C)

CIRCUIT NO.	PART NO.	DESCRIPTION
	FL tube	
Q1704	212163	14-ST-19GK
	Remote sensor	
U1701	241305	GP1U281X
	ICs	
Q1701	22240685R9	M66004FP
Q801-Q803	22240293 or	NJM4558L-D or
Q805	22240247	BA15218N
Q804	22241129R9	AK4520A-VF
Q807	22241130R9	AK4321-VFE1
Q808	222740046R9	74HCU04
Q809	22241126R9TO	TC74HC4040AF
Q810	22240831R3 or 22240940R3	DSP56004FJ50 or DSP56004FJ66
Q811	22241108R9	M5M5256DFP-70L
Q812,Q813	222780053	78L05
	Diodes	
D1701,D1702	223163 or	1SS133 or
D1704	223205	1SS270A
D1705,D1706	225291D	SEL4910D-D
D1703	224471803	MTZJ18C
D801,D802	223163 or 223205	1SS133 or 1SS270A
	Coils	
L801-L808	233454K220	NCH-1452 220K
L810	233454M022	NCH-1452 022M

CIRCUIT NO.	PART NO.	DESCRIPTION
	Oscillator	
X801	3010278	CST12.2MTW040,Ceramic
	Capacitors	
C1705,C1711	375524744	0.47 μ F \pm 5%,50V,Plastic
C1709	353721019	100 μ F,6.3V,Elect.
C1712	353781009	10 μ F,50V,Elect.
C1717	353741009	10 μ F,16V,Elect.
C801-C806	353741009	10 μ F,16V,Elect.
C811,C812	374721524	1500pF \pm 5%,50V,Plastic
C813,C814	353741009	10 μ F,16V,Elect.
C815,C816	374721824	1800pF \pm 5%,50V,Plastic
C817,C818	374721224	1200pF \pm 5%,50V,Plastic
C819,C820	374721524	1500pF \pm 5%,50V,Plastic
C821,C822	374721815	180pF \pm 10%,50V,Plastic
C823,C824	353741009	10 μ F,16V,Elect.
C830	353741009	10 μ F,16V,Elect.
C831,C833	353721019	100 μ F,6.3V,Elect.
C835,C836	353741009	10 μ F,16V,Elect.
C837,C838	374721824	1800pF \pm 5%,50V,Plastic
C839,C840	374721024	1000pF \pm 5%,50V,Plastic
C841,C842	374721524	1500pF \pm 5%,50V,Plastic
C843,C844	374721815	180pF \pm 10%,50V,Plastic
C849,C850	353741009	10 μ F,16V,Elect.
C851,C852	353721019	100 μ F,6.3V,Elect.
C855	353721019	100 μ F,6.3V,Elect.
C858	375524744	0.47 μ F \pm 5%,50V,Plastic
C859	374722234	0.47 μ F \pm 5%,50V,Plastic

DISPLAY CIRCUIT PC BOARD

CIRCUIT NO.	PART NO.	DESCRIPTION
Capacitors		
C861	375524744	0.47 μ F \pm 5%, 50V, Plastic
C864, C867	353721019	100 μ F, 6.3V, Elect.
C868, C869	353741009	10 μ F, 16V, Elect.
Resistors		
R1741	49163103414	RM1/101J-10K*14, Array
Sockets		
JL701b	25051884, 25050946 or 25051344	NSCT-40P1671, NSCT-40P733 or NSCT-40P1133
Switches		
S1701-S1716	25035652	NPS-111-S604
S1717	25035652	NPS-111-S604 <P>
S1718-S1725	25035652	NPS-111-S604
S1727, S1728	25035652	NPS-111-S604
S1730-S1732	25035652	NPS-111-S604
S1734, S1735	25035652	NPS-111-S604
S1737	25065528	EC16B24104
Holders		
U1701a	27191042	Remote sensor
Q1704a	27191001	FL tube

A B C D E F G

SCHEMATIC DIAGRAM

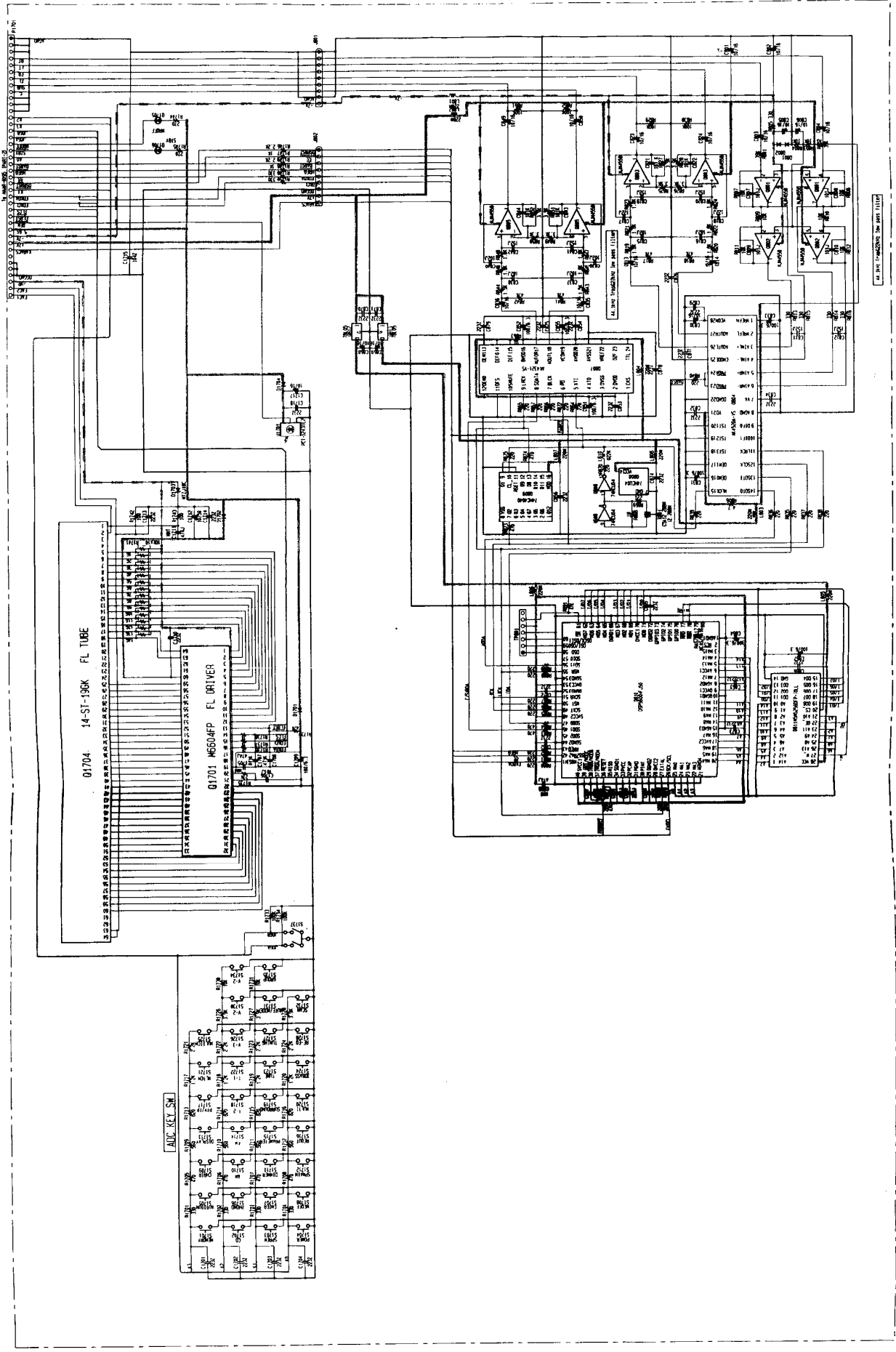

SCHEMATIC DIAGRAM

A B C D E F G

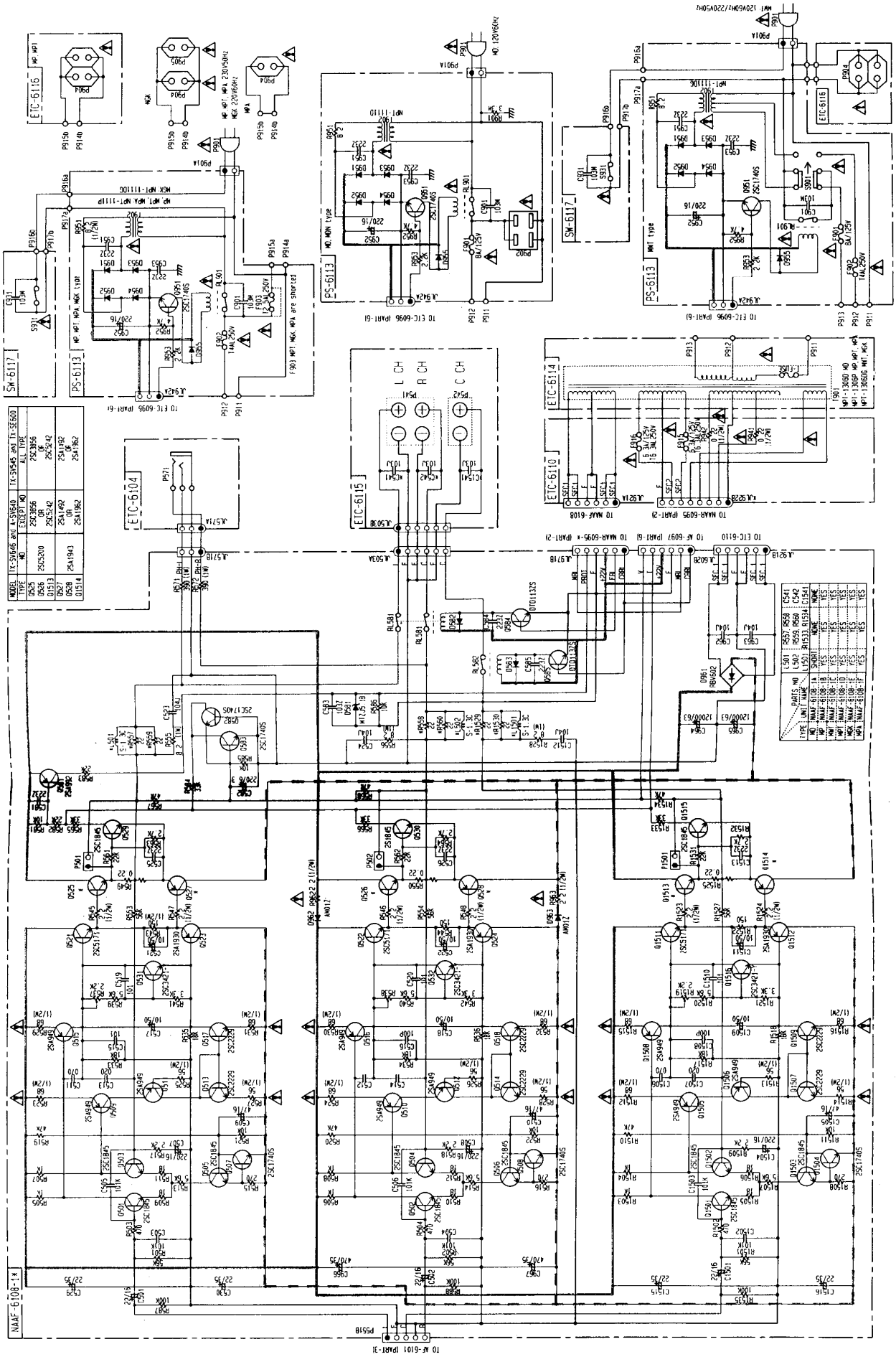

MODE	TX-5106	BU	LS-5640	TS-5104	TS-5105	TS-5106	TS-5107	TS-5108
NO.	250205	250206	250207	250208	250209	250210	250211	250212
TYPE	250205	250206	250207	250208	250209	250210	250211	250212
QTY	1	1	1	1	1	1	1	1

PARTS NO.	QTY	DESCRIPTION	UNIT	REQ.
L501	1	TRANSFORMER		YES
L502	1	TRANSFORMER		YES
L503	1	TRANSFORMER		YES
L504	1	TRANSFORMER		YES
L505	1	TRANSFORMER		YES
L506	1	TRANSFORMER		YES
L507	1	TRANSFORMER		YES
L508	1	TRANSFORMER		YES
L509	1	TRANSFORMER		YES
L510	1	TRANSFORMER		YES
L511	1	TRANSFORMER		YES
L512	1	TRANSFORMER		YES
L513	1	TRANSFORMER		YES
L514	1	TRANSFORMER		YES
L515	1	TRANSFORMER		YES
L516	1	TRANSFORMER		YES
L517	1	TRANSFORMER		YES
L518	1	TRANSFORMER		YES
L519	1	TRANSFORMER		YES
L520	1	TRANSFORMER		YES

ADJUSTMENT PROCEDURES

Idling Current Adjustment

Connect the DC voltmeter to the terminals P501, P502, and P1501 (VCT and IID) on Front/Center power amp. pc board. After turn POWER on, adjust the trim resistors R537, R538, and R1519 so that the indicator of voltmeter becomes 0.5mV.

Connect the DC voltmeter to the terminals P601 and P602 (VCT and IID) on Surround power amp. pc board. After turn POWER on, adjust the trim resistors R637, and R638 so that the indicator of voltmeter becomes 1.5mV.

Allow the unit to warm up for about 5 minutes and check the voltage of these terminals.

When the voltage is less than 4.0mV, adjust trim resistors so that the indicator of voltmeter becomes 4mV.

When the voltage is 4.0mV to 7.5mV, you are not necessary to adjust.

When the voltage is more than 7.5mV, adjust trim resistors so that the indicator of voltmeter becomes 7.5mV.

Note: No load, No signal

PRINTED CIRCUIT BOARD - PARTS LIST

CIRCUIT NO. PART NO. DESCRIPTION			TUNER CIRCUIT PC BOARD(NARF-6109-1A/1B/1C/1D/1E/1F)		
			CIRCUIT NO.	PART NO.	DESCRIPTION
X121	3010141	XTL-7.2M		Front end	
X181	3010203	AF6146CG <P>	TU001	240099	ENV172A0G1 <P/T/W/A/K>
				240107	TFFJ2U552A <D>
				ICs	
C101,C128	354741019	100 μ F,16V,Elect.	Q121	22241076 or	LM7001J or
C130,C159	354780229	2.2 μ F,50V,Elect.		22240090	LM7001
C131	374722234	0.022 μ F \pm 5%,50V,Plastic	Q141	22240983	LA1851N-F
C132,C153	354783399	0.33 μ F,50V,Elect.	Q181	22241124	BU1922 <P>
C133,C142	354741019	100 μ F,16V,Elect.		Transistors	
C145,C149	354780479	4.7 μ F,50V,Elect.	Q101	2210746	2SC945A-P <P/W/T/A/K>
C146	374723324	3300pF \pm 5%,50V,Plastic	Q102	2211723	2SC1923-O
C147	374721034	0.01 μ F \pm 5%,50V,Plastic <P/T/W/A/K>	Q122,Q142	2213510 or	DTA114ES or
C147	374721534	0.015 μ F \pm 5%,50V,Plastic <D>	Q122,Q142	2214350	RN2202
C151,C152	354780109	1 μ F,50V,Elect.	Q123	2212445	2SK365-GR
C154,C162	354741009	10 μ F,16V,Elect.	Q124	2213284 or	2SC1740S-R or
C155,C156	374721034	0.01 μ F \pm 5%,50V,Plastic <D>	Q171,Q172	2212115	2SC2458-GR
C155,C156	374724724	4700pF \pm 5%,50V,Plastic <P/T/A/K>	Q143	221282 or	DTC144ES or
C155,C156	374725624	5600pF \pm 5%,50V,Plastic <W>		2213560	RN1204
C160	354784799	0.47 μ F,50V,Elect.	Q144	2213640 or	DTC123JS or
C166	354741009	10 μ F,16V,Elect.		2214660	RN1205
C168	374724734	0.047 μ F \pm 5%,50V,Plastic	Q173,Q174	2215024	2SD1468S-R
C171,C172	354741009	10 μ F,16V,Elect.	Q175	2213510 or	DTA114ES or
C173,C174	374722724	2700pF \pm 5%,50V,Plastic <P/T/W/A/K>		2214350	RN2202
C175,C176	374721024	1000pF \pm 5%,50V,Plastic <D>	Q182	2213284 or	2SC1740S-R or
C177	354780229	2.2 μ F,50V,Elect.		2212115	2SC2458-GR <P>
C183	354721019	100 μ F,6.3V,Elect. <P>		Diodes	
C184	354780229	2.2 μ F,50V,Elect. <P>	D165	224470512	MTZJ5.1B
C186	374725614	560pF \pm 5%,50V,Plastic <P>		Transformers and coils	
	Resistors		L101	233457	NF1F-4081
R001	431533355	3.3M Ω ,1/2W,Solid <D>	L102	233458	NF1F-4082
R150	5210261	N06HR5KBC,Trimming	L103	233501	NMC-3088 <P/T/W/A/K>
R158	5210263	N06HR20KBC,Trimming	L104	233454M022	NCH-1452 022M
	Terminals		L105	232174	NMRF-5077
P101	25060239 or	NTM-4PDML161 or	L106	232176	NM1F-6094
	25060195	NTM-4PDML117 <D>	L107,L108	233484	NMC-4085 <P/T/W/A/K>
	25060222 or	NTM-2PDML144 or	L109,L110	231092	NCH-2140 <D>
	25060117	NTM-2PDML051 <P/T/W/A/K>	L181	233454K220	NCH-1452 220K <P>
	Sockets			Ceramic filters	
P102b	25050986	NSCT-14P773 <D/T/W/A/K>	X101	3010071	SFE-10.7MA5 RED
P102b	25050987	NSCT-16P774 <P>	X102	3010071	SFE-10.7MA5 RED <P/T/W/A/K>
	Switch		X103	3010071	SFE-10.7MA5 RED <D>
S101	25065286	NSS-22112 <W>	X103	3010130	SFE10.7MZZK <P/T/W/A/K>
	Plug		X104	3010268	CSB456F23
TP101	25055038	NPLG-2P29			

PRINTED CIRCUIT BOARD VIEW FROM BOTTOM SIDE

TUNER CIRCUIT PC BOARD

LA1851N-F (FM IF, MPX and AM Radio System)

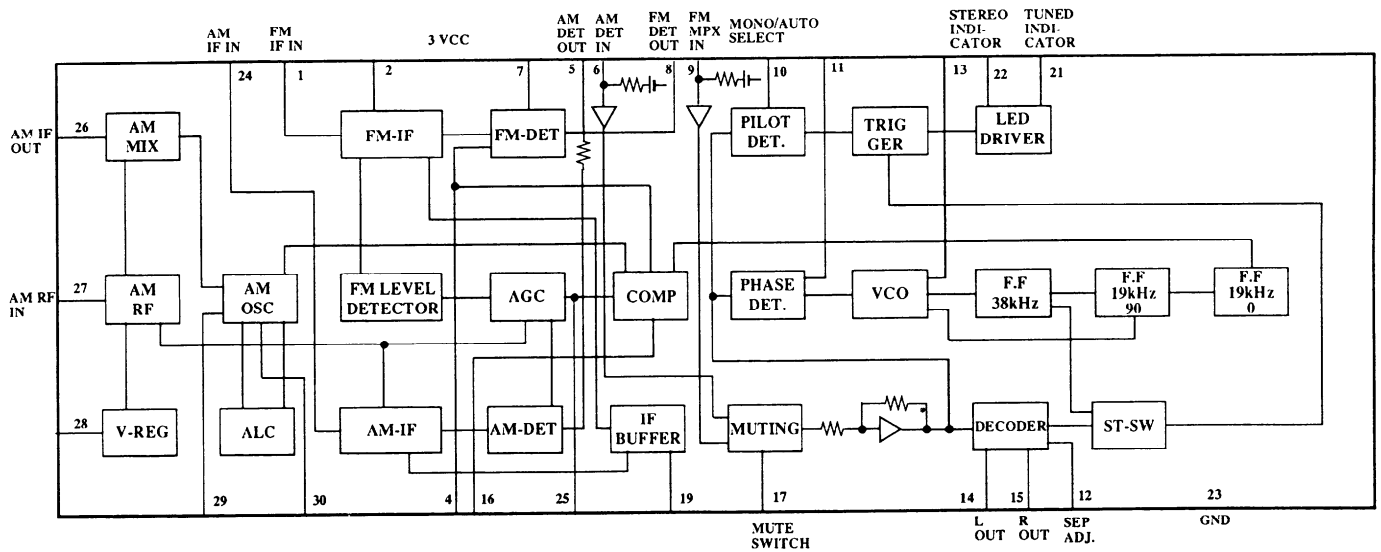

A B C D E F G

SCHEMATIC DIAGRAM

NARF-6109

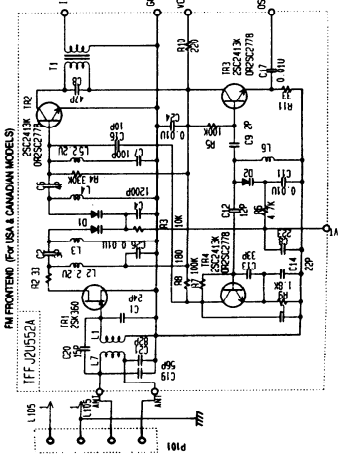
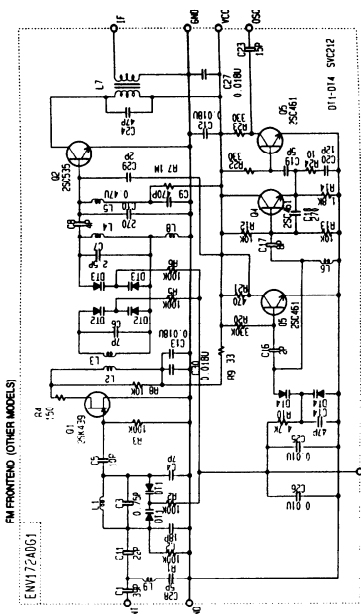
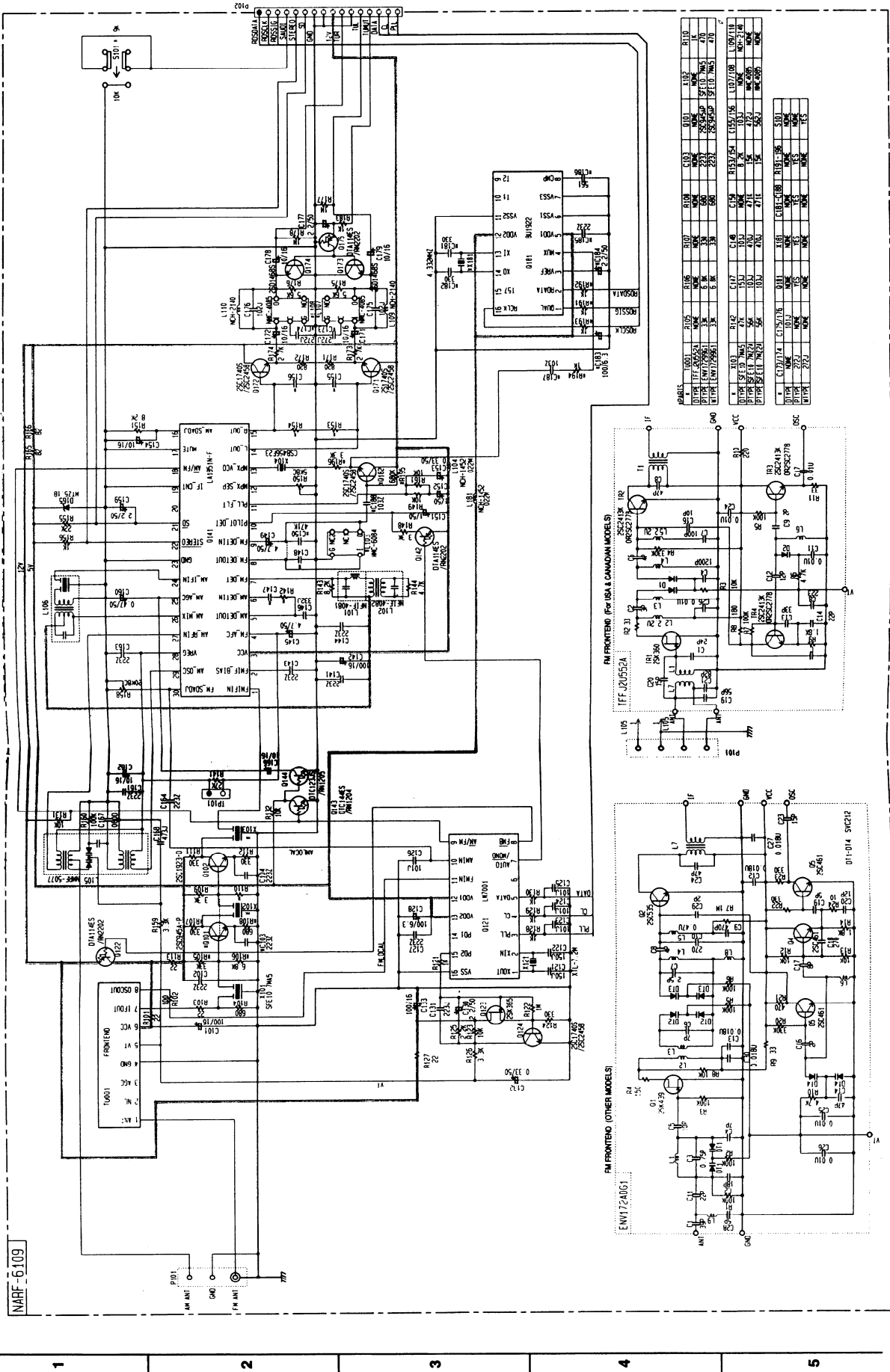

1001	1002	1003	1004	1005	1006	1007	1008	1009	1010	1011	1012
1001	1002	1003	1004	1005	1006	1007	1008	1009	1010	1011	1012
1001	1002	1003	1004	1005	1006	1007	1008	1009	1010	1011	1012
1001	1002	1003	1004	1005	1006	1007	1008	1009	1010	1011	1012
1001	1002	1003	1004	1005	1006	1007	1008	1009	1010	1011	1012

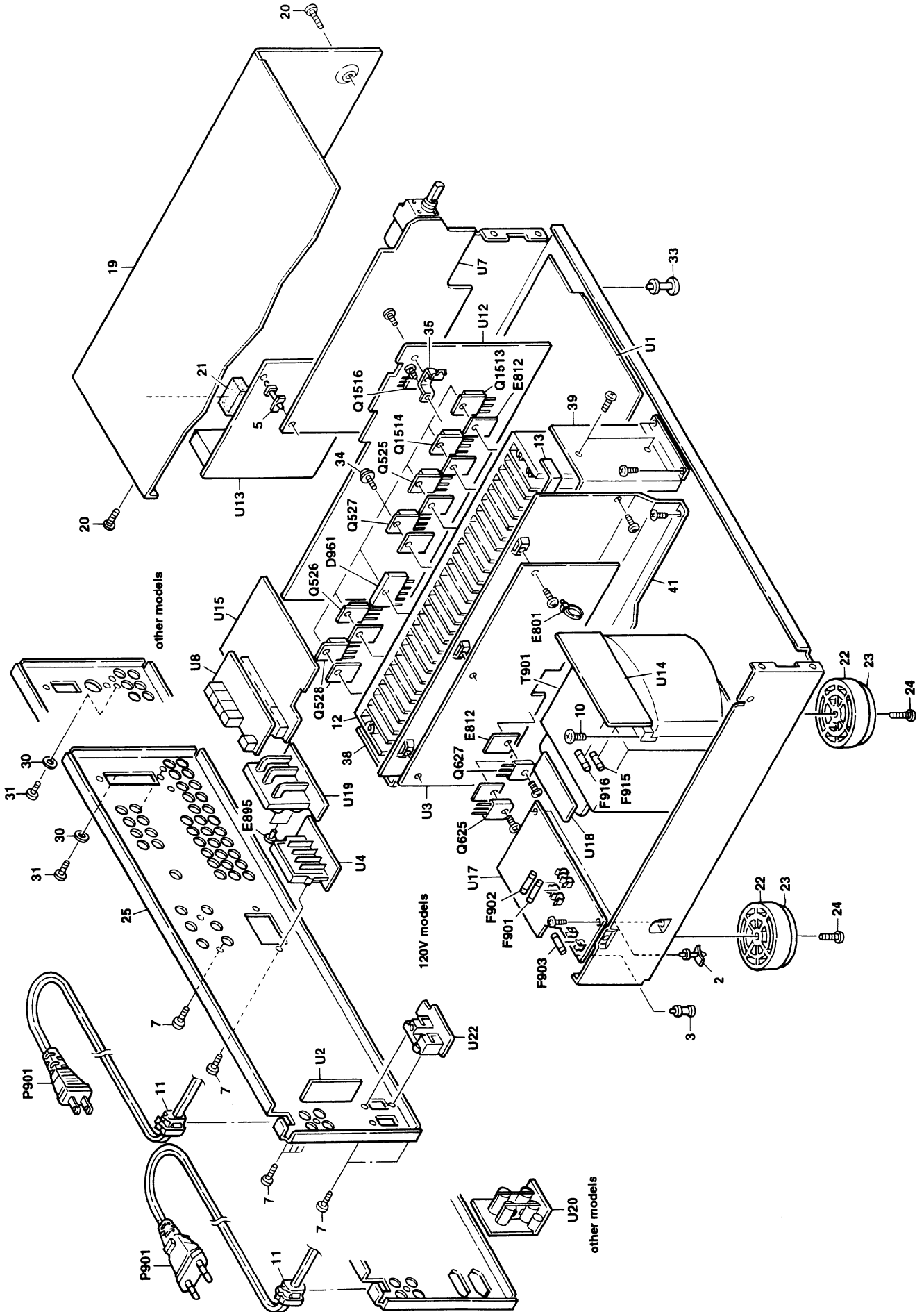

PARTS LIST

REF. NO.	PART NO.	DESCRIPTION	REF. NO.	PART NO.	DESCRIPTION
1	27100328A	Chassis	60	27215278	Decorative frame
2	27190503A	KGLS-10RF, Holder	63	27191014	Holder
3	27190428A	KGLS-12S, Holder	68	28325542	Knob, Mdbde
5	27190062	3TTB+8B, Self-tapping screw	69	28325543	Knob, Mdbde <S>
7	838130088	4TTC+8C(BC), Self-tapping screw	70	28191792A	Clear plate
10	830440089	#2271, Bushing cord	71	28191793A	Clear plate <S>
11	27300750	Heatsink	72	28325497A	Knob, Power <P/T/W/A/K>
12	27160387	Tape	74	28325547	Knob, Power <S>
13	29110083	Knob, Volume 	D961	27273164	Joint <P/T/W/A/K>
16	28325539	Knob, Volume <S>		27141686A	Retainer <P/T/W/A/K>
17	28325540	Knob, Tone 		838430107	3TTP+10S(BC), Self-tapping screw
18	28325405	Knob, Tone <S>		△ D5SBA60,	
18	28325500	Knob, Jog 		△ RBV602 or	
19	28325538	Knob, Jog <S>		△ RS603M, Diode	
19	28184698	Top cover 	E801	22380038 or	Wire tie
20	838430088	Top cover <S>	E812	22380274	AC238, Isolation sheet
20	838430088	3TTB+8B(BC), Self-tapping screw 	E895	260208	NRP-345, Plastic rivet <P/T/A>
21	838230080	3TTB+8B(Ni), Self-tapping screw <S>	F901	22302024	8A-UL, Primary fuse <D/W>
21	28141235	Cushion	F902	252198	4A-SE-EAK, Primary fuse <P/T/W/A/K>
22	27175319A	Leg	F903	252075	2.5A-SE-EAK, Fuse <P>
23	28141332	Cushion	F915, F916	252074	2A-SE-EAK Fuse <T/A>
24	831430088	3TTW+8B(BC), Self-tapping screw		252166	6.3A-UL/T-237, Secondary fuse <D>
25	27122362	Rear panel <D>	JL701	252079	6.3A-SE-EAK, Secondary fuse <P/T/W/A/K>
	27122363	Rear panel <P>	P901	2047402512	NCFC7-402512, Flat cable
	27122364	Rear panel <T>		253192HIT	AS-UC-6#18(SPT-2), Power supply cord <D>
	27122365A	Rear panel <W>		253193HIT	AS-CEE, Power supply cord <P/T>
	27122367	Rear panel <A>		253197HIT	AS-CEE-2, Power supply cord <W>
	27122366	Rear panel <K>		253213WSE	AS-SAA, Power supply cord <A>
26	27190470	KGLS-18S, Holder	P904	25051570	AS-KS, Power supply cord <K>
29	27300243	WS 2W, Clamp	P904, P905	25051266	NSCT-2P1357, AC outlet <A>
30	87643010	W3*10F(BC), Washer	Q1516	2212654 or	NSCT-2P1056, AC outlet <K>
31	838230088	3TTB+8B(Ni), Nickel screw	Q531, Q532	2212653	2SC3421-Y or
33	27190813	KGPS-10RF, Holder	Q625, Q626	2202922,	2SC5196-R, Transistor
34	801433	3SMS8W.SW+14B(BC), Special screw		2202923,	2SC5196-O,
35	27141681	Retainer		2202373,	2SC4466-O,
36	28140680	Cushion		2202375 or	2SC4466-P or
38	27141693	Retainer, Rear		2202374	2SC4466-Y, Transistor
39	27141694	Retainer, Front	Q627, Q628	2202912,	2SA1939-R,
41	27160386	Heatsink		2202913,	2SA1939-O,
52	27211941	Front panel <D>		2202363,	2SA1693-O,
	27211942	Front panel <P>		2202365 or	2SA1693-P or
	27211940	Front panel <T/W/A/K>	Q1513	2202364	2SA1693-Y, Transistor
	27211943	Front panel <S>	Q525, Q526	2201653,	2SC3856-O,
53	28135244	Badge 		2201655,	2SC3856-P,
54	28135245	Badge <S>		2201654,	2SC3856-Y,
59	28198778	Facet		2202842 or	2SC5242-R or
	27111017	Front bracket <D/T/W/A/K>		2202843	2SC5242-O, Transistor
	27111018	Front bracket <P>		2201663,	2SA1492-O,
	27111019	Front bracket <S>			

NOTE: <D>: 120V model only
 <P>: European model only
 <T>: Asian model only
 <W>: Worldwide model only
 <A>: Australian model only
 <K>: Korean model only
 : Black model only
 <S>: Silver model only

SCHEMATIC DIAGRAM

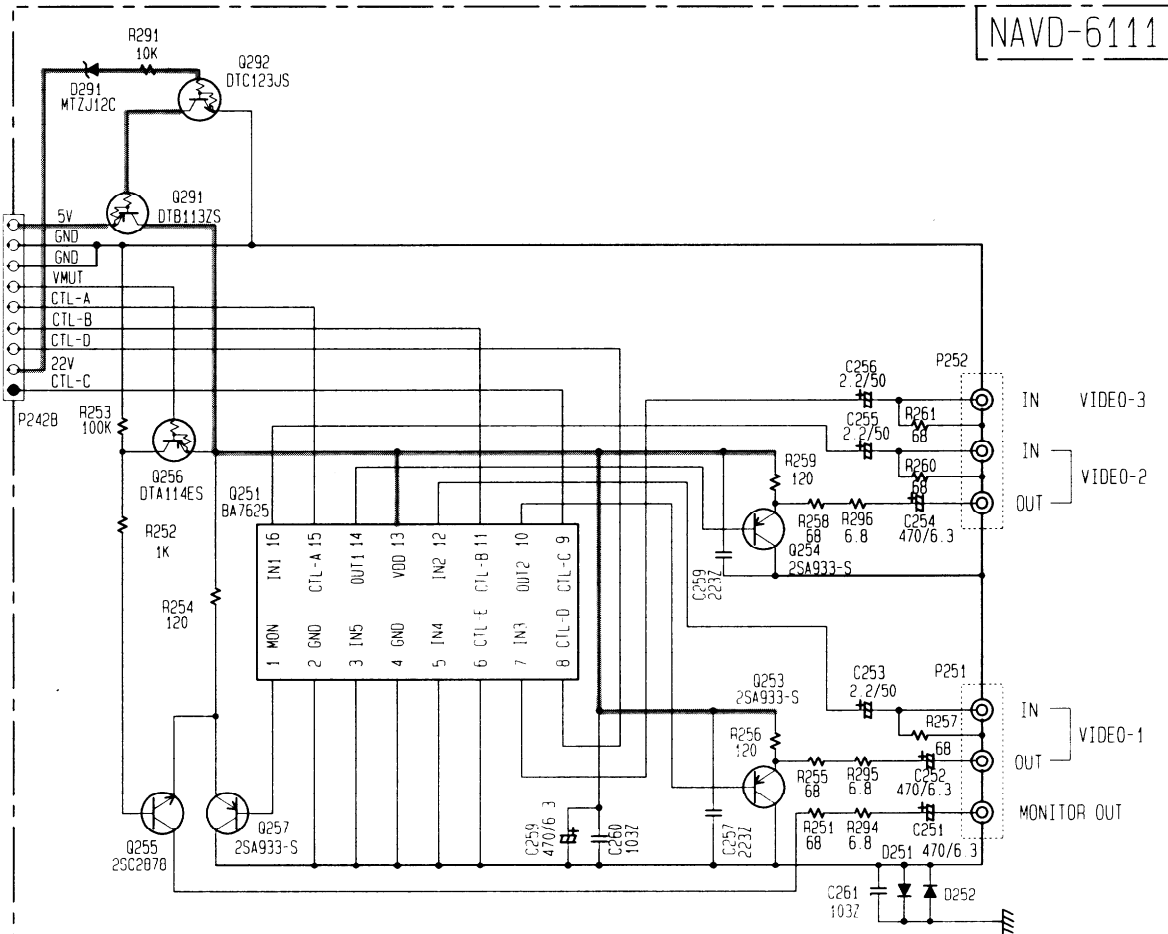

PRINTED CIRCUIT BOARD-PARTS LIST

VIDEO CIRCUIT PC BOARD(NAETC-6112-1A/1B/1C/1D/1E/1F)

CIRCUIT NO.	PART NO.	DESCRIPTION
IC		
Q251	22240373	BA7625
Transistors		
Q252-Q254	2213354 or 2212125	2SA933S-R or 2SA1048-GR
Q255	2212286 or 2212285	2SC2878-B or 2SC2878-A
Q256	2213510 or 2214350	DTA114ES or RN2202
Q291	2213830	DTB113ZS
Q292	2213640	DTC123JS
Diodes		
D251,D252	223205 or 223163	1SS270A or 1SS133
D291	224471203	MTZJ12C
Capacitors		
C251,C252	354724719	470 μ F,6.3V,Elect.
C253,C255	354780229	2.2 μ F,50V,Elect.
C254	354724719	470 μ F,6.3V,Elect.
C256	354780229	2.2 μ F,50V,Elect.
C259	354721029	1000 μ F,6.3V,Elect.
Terminals		
P251,P252	25045457 or 25045299	NPJ-3PDYE278 or NPJ-3PDYE158
Plug		
JL242c	25055630	NPLC-9P592

BA7625(Video Selector Switch)

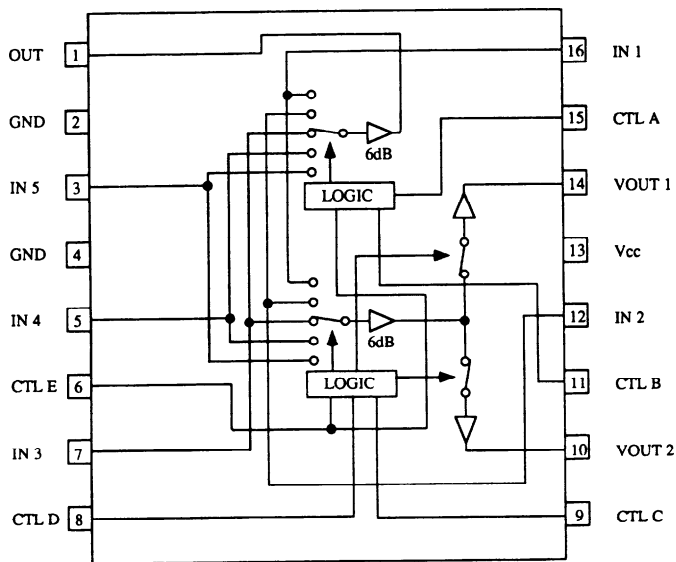

#15	#11	#6	#1
A	B	E	MONITOR OUT
L	L	X	IN1
H	L	X	IN2
L	H	X	IN3
H	H	L	IN4
H	H	H	IN5

#9	#8	#6	#14
C	D	E	VOUT1
L	L	X	
H	L	X	IN2
L	H	X	IN3
H	H	L	IN4
H	H	H	IN5

X:Don't care

#15	#11	#6	#10
A	B	E	VOUT 2
L	L	X	IN1
H	L	X	
L	H	X	IN3
H	H	L	IN4
H	H	H	IN5

BLOCK DIAGRAM TUNER SECTION

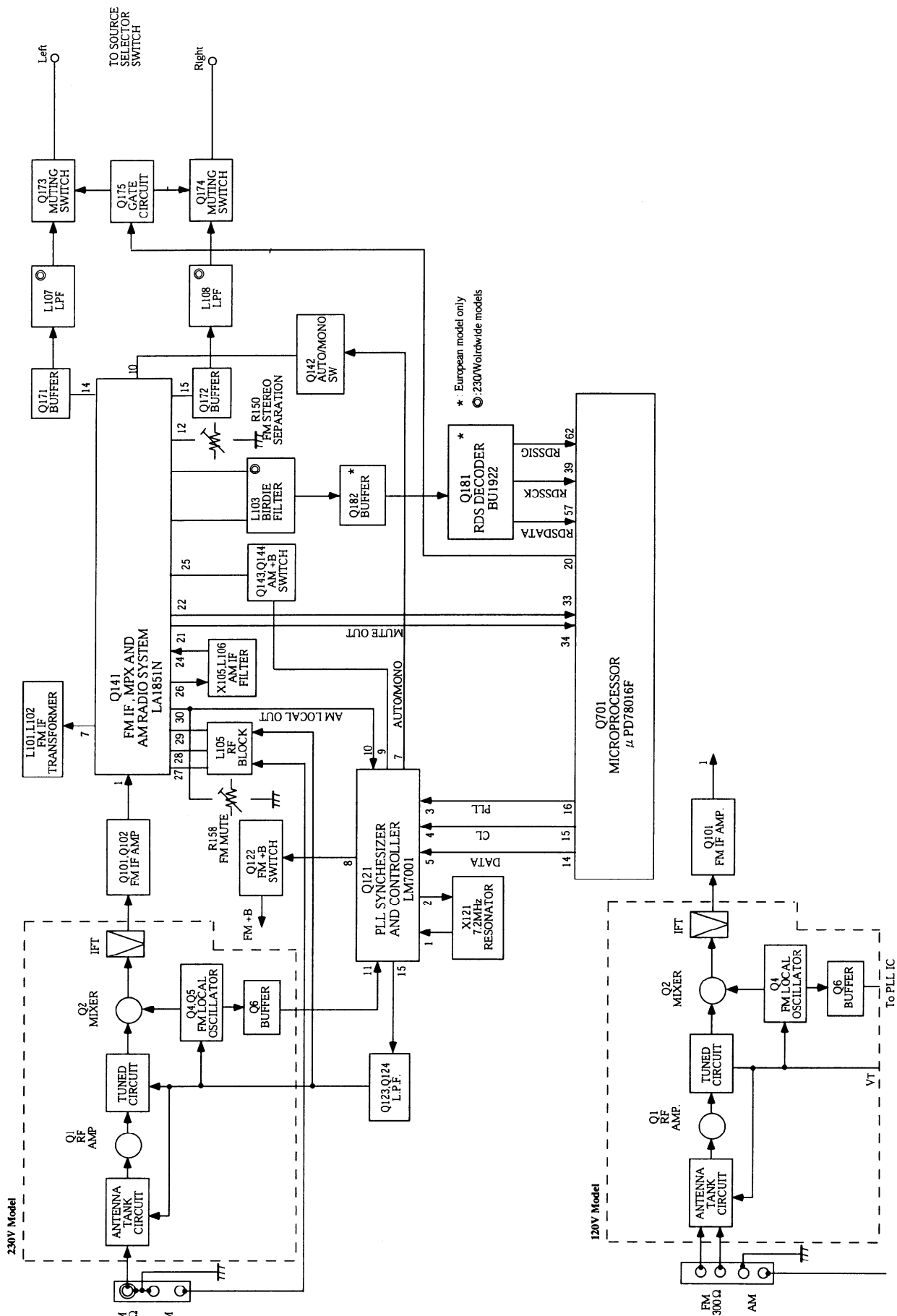

PACKING VIEW

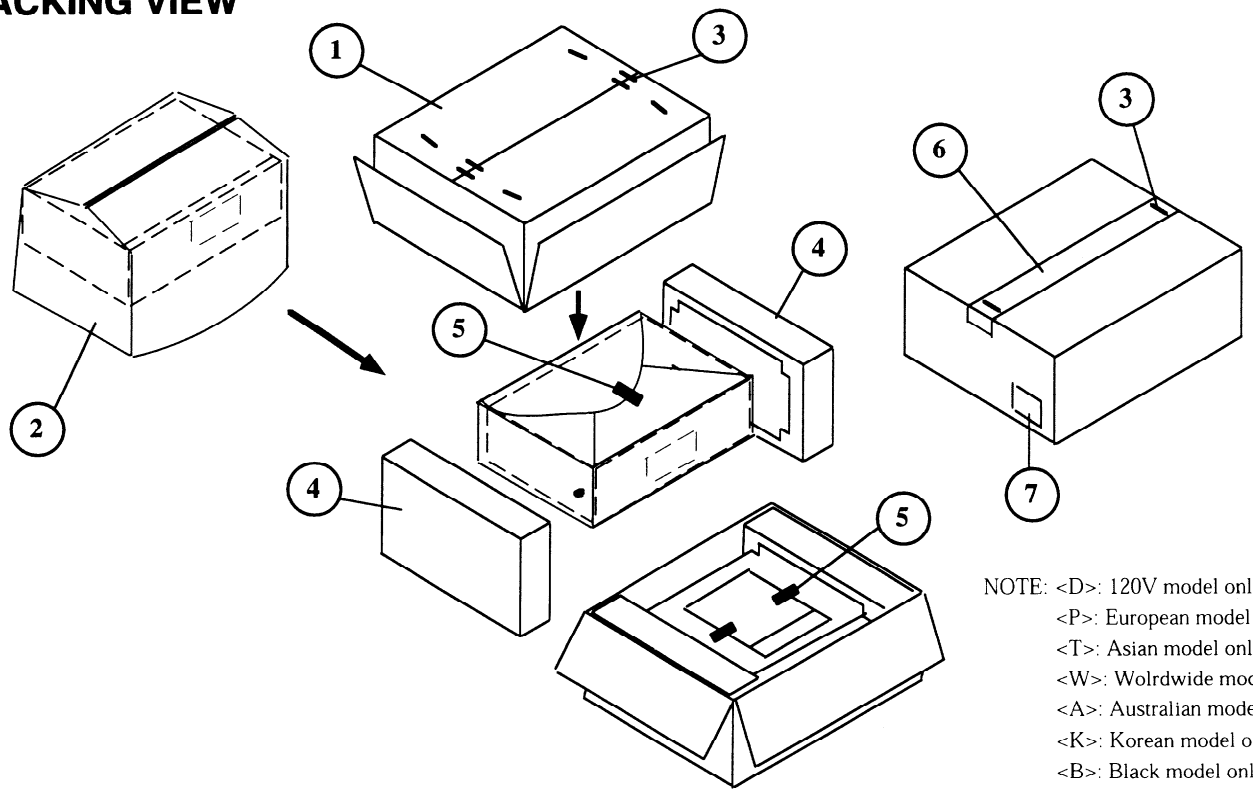

NOTE: <D>: 120V model only
 <P>: European model only
 <T>: Asian model only
 <W>: Worldwide model only
 <A>: Australian model only
 <K>: Korean model only
 : Black model only
 <S>: Silver model only

REF. NO.	PART NO.	DESCRIPTION	REF. NO.	PART NO.	DESCRIPTION
1	29053197	Carton <D>	8	Accessory bag ass'y	
	29053198	Carton <P>		232140	NMA-3057, Antenna coil
	29053199	Carton <T/W/A/K>		24140343	RC-343M, Remote control <D>
	29053200	Carton <S>		24140344	RC-344S, Remote control <P/T/W/A/K>
2	29100034-1A	850*650, Poly bag		25055018	CV-K-1, Conversion plug <W>
3	282301	Staple		25065462	YAE21-0237, FM antenna adaptor
4	29091796A	Pad			<P/T/W/A/K>
5	261504	Adhesive tape		29100097-1A	350*250, Poly bag
6	29110071	PP tape		292111	FM antenna <D>
7	29362208	UPC label <D>		292112	FM antenna <P/T/W/A/K>
	29362209	EAN label <P/T/W/A/K>		29342471A	Instruction manual E
	29362210	EAN label <S>		29342472	Instruction manual FSI <P>
				29342473	Instruction manual GSwD <P>
				29342474A	Instruction manual T <T/W>
				29358002K	Service Station list <D>
				29365019B	Warranty card <D>
				3010194	UM-3, Battery

ONKYO CORPORATION

International Sales Div.: 31 Sankyo-bld. 3-8-5, Asakusabashi, Taito-ku, TOKYO 111, JAPAN
 TEL : 03-5820-5865 FAX : 03-5820-5869

ONKYO U.S.A. CORPORATION
 200 Williams Drive, Ramsey, N.J. 07446, U.S.A.
 TEL : 201-825-7950 FAX : 201-825-8150

ONKYO EUROPE ELECTRONICS GmbH
 Industriestrasse 18-20, 82110 Germering, GERMANY
 TEL : 089 84 93 20 FAX : 089 84 93 226

ONKYO FRANCE
 Immeuble Le Diamant, Domaine Technologique de Saclay, 4 Rue Rene Razel, 91892 SACLAY, FRANCE
 TEL : (1) 69 33 1400 FAX : (1) 69 41 35 84