

ONKYO SERVICE MANUAL

QUARTZ SYNTHESIZED TUNER AMPLIFIER MODEL TX-V940 MODEL TX-V940RDS MODEL TX-SV414PRO

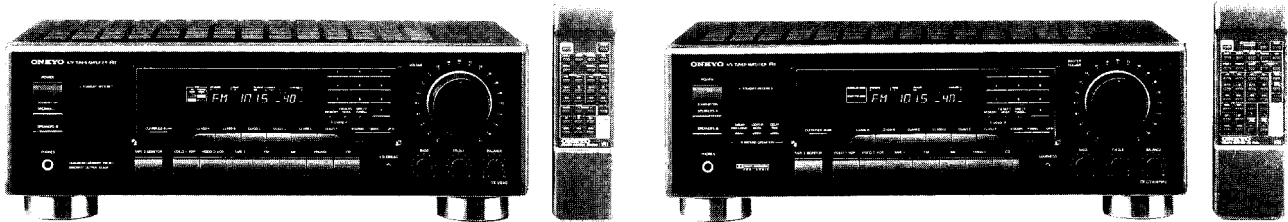

Black model

BMD, BMDN	120V AC, 60Hz
BMP	230V AC, 50Hz
BMW	120V or 220V AC, 50/60Hz

SAFETY-RELATED COMPONENT WARNING!!

COMPONENTS IDENTIFIED BY MARK Δ ON THE SCHEMATIC DIAGRAM AND IN THE PARTS LIST ARE CRITICAL FOR RISK OF FIRE AND ELECTRIC SHOCK. REPLACE THESE COMPONENTS WITH ONKYO PARTS WHOSE PART NUMBERS APPEAR AS SHOWN IN THIS MANUAL.

MAKE LEAKAGE-CURRENT OR RESISTANCE MEASUREMENTS TO DETERMINE THAT EXPOSED PARTS ARE ACCEPTABLY INSULATED FROM THE SUPPLY CIRCUIT BEFORE RETURNING THE APPLIANCE TO THE CUSTOMER.

TABLE OF CONTENTS

Specifications.....	2
Service procedures.....	3
Exploded view TX-SV414PRO.....	4
Parts list TX-SV414PRO.....	5
Exploded view TX-V940/TX-V940RDS.....	6
Parts list TX-V940/TX-V940RDS	7
Block diagram Tuner section.....	8
Block diagram TX-SV414PRO.....	10
Block diagram TX-V940/TX-V940RDS.....	11
Microprocessor connection diagram.....	12
Microprocessor terminal description.....	13
IC block diagrams and descriptions.....	14
Adjustment procedures.....	20
Printed circuit board views from bottom side.....	23
Schematic diagram TX-V940.....	25
Schematic diagram TX-V940RDS.....	29
Schematic diagram TX-SV414PRO.....	33
Printed circuit board views from bottom side.....	37
Schematic diagram TX-SV414PRO.....	41
Printed circuit board-parts list TX-V940/TX-V940RDS.....	43
Printed circuit board-parts list TX-SV414PRO.....	47
Packing view.....	52

ONKYO
AUDIO COMPONENTS

SPECIFICATIONS

AMPLIFIER SECTION

TX-V940/TX-V940RDS

Power Output: USA & Canadian models:
100 watts per channel, min. RMS, at 8 ohms, both channels driven, from 40 Hz to 20 kHz with no more than 0.2% THD.
Other than USA & Canadian models:
Continuous output
2 × 100 watts at 4 ohms 1 kHz (DIN)
2 × 75 watts at 8 ohms 1 kHz (DIN)

Total Harmonic Distortion: 0.08% at power 30 watts
IM Distortion: 0.08% at power 30 watts
Damping Factor: 50 at 8 ohms
Sensitivity and Impedance: Phono: 2.5 mV/50 kohms
CD/Tape Play: 150 mV/50 kohms
Tape Rec: 150 mV/2.2 kohms

Phono Overload: 120 mV RMS, at 1,000 Hz, 0.5% THD.
Frequency Response: 20 to 30,000 Hz, +/-1 dB
RIAA Deviation: 20 to 20,000 Hz, +/-0.8 dB
Tone Control: BASS: +/-10 dB at 100 Hz
TREBLE: +/-10 dB at 10,000 Hz
Signal to Noise Ratio: PHONO: 80 dB (IHF A, 5 mV input)
CD/TAPE: 100 dB (IHF A)

VIDEO SECTION

Signal sensitivity and impedance: VDP/VCR input, output: 1 Vp-p, 75 ohms

TUNER SECTION

FM:

Tuning Range: 87.5 — 108.0 MHz
Usable Sensitivity: Mono: 11.2 dBf, 1.0 μV (75 ohms)
Stereo: 17.2 dBf, 2.0 μV (75 ohms)
50dB Quieting Sensitivity: Mono: 18.2 dBf, 2.2 μV (75 ohms)
Stereo: 38.2 dBf, 22 μV (75 ohms)
Capture Ratio: 1.5 dB
Image Rejection Ratio: USA & Canadian models: 40 dB
Other area models: 85 dB
IF Rejection Ratio: 90 dB
Signal-to-Noise Ratio: Mono: 73 dB
Stereo: 67 dB
Alternate Channel Attenuation: 55 dB
Selectivity: 50 dB (DIN)
AM Suppression Ratio: 50 dB
Total Harmonic Distortion: Mono: 0.15%
Stereo: 0.25%
Frequency Response: 30 — 15,000 Hz +/-1.5 dB
Stereo Separation: 45 dB at 1 kHz/30 dB at 100 — 10,000 Hz

AM:

Tuning Range: USA & Canadian models: 530 — 1710 kHz (10 kHz steps)
European models: 522 — 1611 kHz (9kHz steps)
Worldwide models: 531 — 1602 kHz (9 kHz steps),
530 — 1710 kHz (10 kHz steps)
Usable Sensitivity: 30 μV
Image Rejection Ratio: 40 dB
IF Rejection Ratio: 40 dB
Signal-to-Noise Ratio: 40 dB
Total Harmonic Distortion: 0.7%

GENERAL

Power Supply: USA & Canadian models: AC120 V, 60 Hz
European models: AC 230V, 50 Hz
UK & Australian models: AC 240 V, 50 Hz
Worldwide models: 220 V and 120 V switchable
50/60 Hz
Dimensions (W × H × D): 455 × 150 × 331 mm
17-15/16" × 5-7/8" × 13-1/16"
Weight: 9.5 kg (20.9 lbs)

TX-SV414PRO

Stereo mode

Front L/R channels
60 watts per channel min. RMS, at 8 ohms, both channels driven, from 20 Hz to 20,000 Hz, with no more than 0.08% total harmonic distortion.
Continuous Power output:
2 × 90 watts 4 ohms 1 kHz (DIN)
2 × 70 watts 8 ohms 1 kHz (DIN)

Surround mode

Front L/R and center channels
50 watts per channel min. RMS at 8 ohms, with no more than 0.08% total harmonic distortion at 1,000 Hz
Rear channels
15 watts per channel min. RMS at 8 ohms with no more than 0.3% total harmonic distortion at 1,000 Hz
0.08% at rated power (FRONT)
0.08% at rated power (FRONT)
50 at 8 ohms (FRONT)
Phono: 2.5 mV/50 kohms
CD/Tape Play: 150 mV/50 kohms
Tape Rec: 150 mV/2.2 kohms
Mono out (SUBWOOFER): 1V 2.2 kohms
120 mV RMS, at 1,000 Hz, 0.5% THD.
20 to 30,000 Hz, +/-1 dB
20 to 20,000 Hz, +/-0.8 dB
BASS: +/-10 dB at 100 Hz
TREBLE: +/-10 dB at 10,000 Hz
PHONO: 80 dB (IHF A, 5 mV input)
CD/TAPE: 100 dB (IHF A)

VDP/VCR input, output: 1 Vp-p, 75 ohms

87.5 — 108.0 MHz
Mono: 11.2 dBf, 1.0 μV (75 ohms)
Stereo: 17.2 dBf, 2.0 μV (75 ohms)
Mono: 18.2 dBf, 2.2 μV (75 ohms)
Stereo: 38.2 dBf, 22 μV (75 ohms)
1.5 dB
USA & Canadian models: 40dB
Other area models: 85 dB
90 dB
Mono: 73 dB
Stereo: 67 dB
55 dB
50 dB (DIN)
50 dB
Mono: 0.15%
Stereo: 0.25%
30 — 15,000 Hz +/-1.5 dB
45 dB at 1 kHz/30 dB at 100 — 10,000 Hz

USA & Canadian models: 530 — 1710 kHz (10 kHz steps)
European models: 522 — 1611 kHz (9kHz steps)
Worldwide models: 531 — 1602 kHz (9 kHz steps),
530 — 1710 kHz (10 kHz steps)
30 μV
40 dB
40 dB
40 dB
0.7%

USA & Canadian models: AC120 V, 60 Hz
European models: AC 230V, 50 Hz
UK & Australian models: AC 240 V, 50 Hz
Worldwide models: 220 V and 120 V switchable
50/60 Hz
455 × 150 × 331 mm
17-15/16" × 5-7/8" × 13-1/16"
10.2 kg (22.5 lbs)

Remote control transmitter RC-223S

Transmitter: Infrared
Signal range: Approx. 5 meters (16ft. X 4")
Power supply: Two "AA" batteries(1.5V X 2)

Specifications and features are subject to change without notice.

SERVICE PROCEDURES

1.Replacing the fuses

 This symbol located near the fuse indicates that the fuse used is fast operating type. For continued protection against fire hazard, replace with same type fuse. For fuse rating, refer to the marking adjacent to the symbol.

 Ce symbole indique que le fusible utilise est a rapide. Pour une protection permanente, n'utiliser que des fusibles de meme type. Ce dernier est indique la qu le present symbol est appose.

Circuit No.	Part No.	Descriptions	Models	Remarks
F901	252166Y	6.3A UL/T-237,Primary	MD/MW	
F902	252076	3.15A-SE-EAK,Primary	MP/MW	
F903	252075	2.5A-SE-EAK,AC outlet	MP	
F921,F922	252166Y	6.3A-UL/T-237,Secondary	MD	TX-SV414PRO only
F921,F922	252079	6.3A-SE-EAK,SEcondary	MP/MW	TX-SV414PRO only

2.Safety-check out

(Only U.S.A. model)

After correcting the original service problem,perform the following safety check before releasing the set to the customer.

Connect the insulating-resistance tester between the plug of power suuply cord and nickel screw on the back panel.

Specifications: 3.3Mohm \pm 10% at 500V.

3.Change of voltage

Worldwide models are equipped with a voltage selector to conform with local power supplies. This switch is located on the back panel. Be sure to set this switch to match the voltage of the power supply in your area before turning the power switch on.

This swith is set to 220V at the factory. Voltage is changed by sliding the groove in the switch with the screwdriver to the right or left. Confirm that the switch has been moved all the way to the right or left before turning the power switch on.

4.Step band selector switch

Worldwide models are equipped with a step band selector switch. This switch is located on the back panel. This switch is set to 9kHz (AM) at the factory, but may have to be reset to 10kHz depending on the area where the unit is used.

	AM step
Europe: 50 μ sec	9kHz
U.S.A.: 75 μ sec	10kHz

5.Changing the band step

With the exception of the models below, a BAND STEP selector switch is not provided.

<AM>

MODEL	BAND STEP	R727
MD	10kHz to 9kHz	47 k Ω
MP	9kHz to 10kHz	22 k Ω

6.Memroy preservation

This unit does not require memory preservation batteries. A built-in memory power back-up system preserves contents of the memory during power failures and even when the unit is unplugged. The unit must be plugged in and the power switch turned on and off once in order to charge the back-up system. Note that since this is not a permanent memory,the power switch must be turned on and off a few times each month to keep the back-up system operative. The period of time during which memory contents are preserved after power has last been turned off varies depending on climate and placement of the unit. On the average, memory contents are protected over a period of 3 to 4 weeks (a minimum of 2 weeks) after the last time power has been turned off. This period is shorter when the unit is exposed to very high humidity or used in an area with an extremely humid climate.

EXPLODED VIEW

MODEL TX-SV414PRO

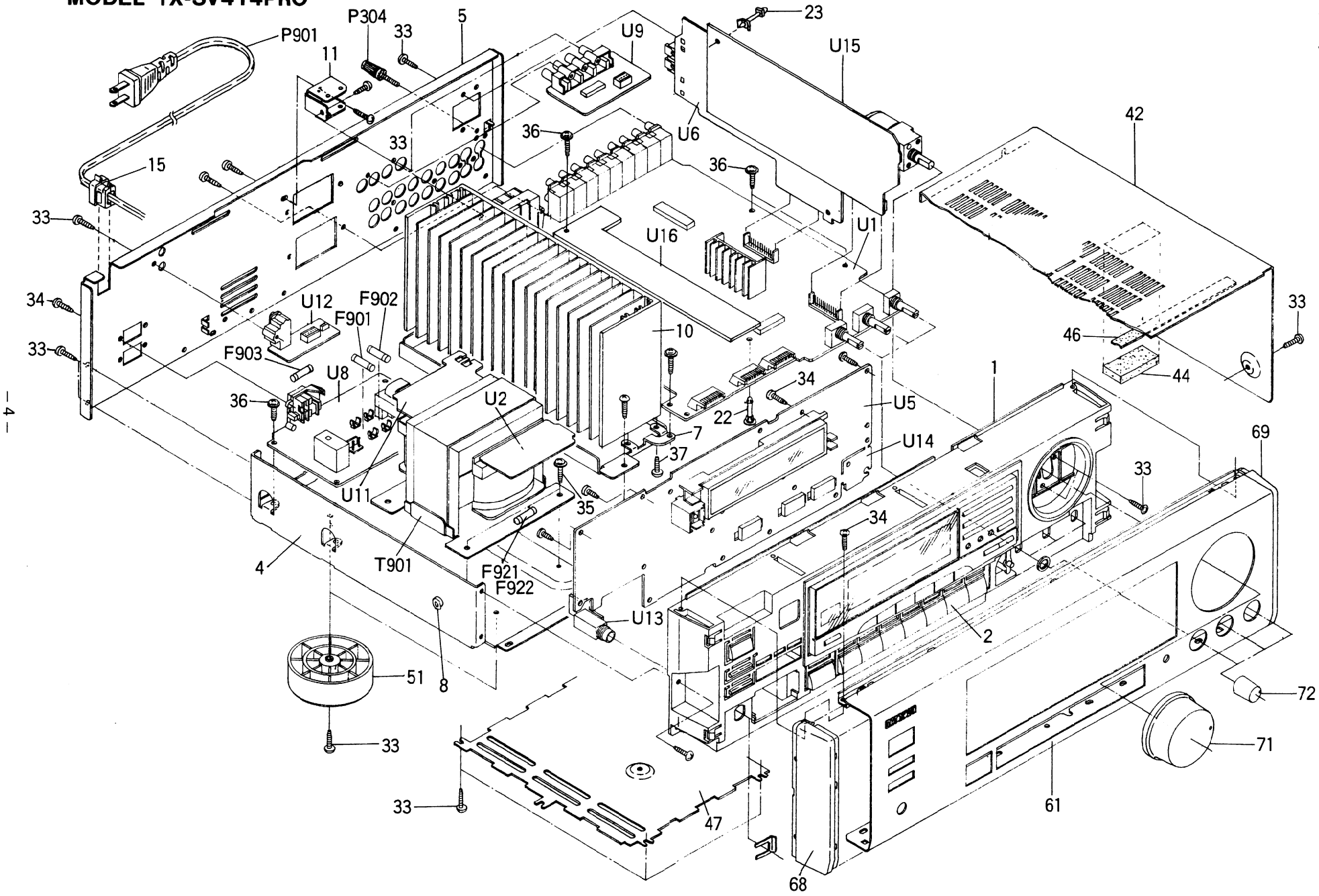

PARTS LIST

REF. NO.	PART NO.	DESCRIPTION	REF. NO.	PART NO.	DESCRIPTION	REF. NO.	PART NO.	DESCRIPTION
1	27110794Y	Front bracket	P304	25060044	Terminal	U6	1A472598-1Y	NARF-4898-1,Tuner circuit pc board ass'y <D>
2	28324929AY	Knob CLA	P901	253192HIT	⚠ AS-UC-6#18,Power supply cord <D/PX>		1A472598-1AY	NARF-4898-1A,Tuner circuit pc board ass'y <P>
3	28175209Y	Isolating plate		253193HIT	⚠ AS-CEE,Power supply cord <P/W>		1A472598-1BY	NARF-4898-1B,Tuner circuit pc board ass'y <W>
4	27100278AY	Chassis	Q521,Q522	2202523,	2SC4468-O,	U8	1A472500-1Y	NAPS-4900-1,Power supply circuit pc board ass'y <D>
5	27121825AY	Rear panel <D>		2202524,	2SC4468-Y,		1A472500-1AY	NAPS-4900-1A,Power supply circuit pc board ass'y <P>
	27121826AY	Rear panel <P>		2202526,	2SC4468-P,		1A472500-1BY	NAPS-4900-1B,Power supply circuit pc board ass'y <W>
	27121828AY	Rear panel <W>		2202292 or	2SC3182N-R or		1A472500-1DY	NAPS-4900-1D,Power supply circuit pc board ass'y <PX>
	27121829AY	Rear panel <PX>		2202293	2SC3182N-O,Transistors	U9	1A472501-1Y	NAETC-4901-1,Video circuit pc board ass'y
	27121842AY	Rear panel <C>	Q523,Q524	2202513,	2SA1695-O,	U11	1A472503-1Y	NAETC-4903-1,Primary circuit pc board ass'y
7	27130727Y	Bracket H		2202514,	2SA1695-Y,	U12	1A472504-1Y	NAETC-4904-1,RI terminal pc board ass'y <D/P>
8	27270212Y	Spacer <P/W>		2202516,	2SA1695-P,		1A472504-1BY	NAETC-4904-1B,RI terminal pc board ass'y <W>
10	27160330AY	Radiator		2202282 or	2SA1265N-R or	U13	1A472505-1Y	NAETC-4905-1,Headphone terminal pc board ass'y
11	27141623Y	Retainer H		2202283,	2SA1265N-O,Transistors	U14	1A472506-1Y	NASW-4906-1,Loudness switch pc board ass'y
13	27141530AY	Retainer HS-2	Q821	2202253,	2SC4467-O,	U15	1A472508-1Y	NAAF-4908-1,Surround circuit pc board ass'y
15	27300750	⚠ Bushing cord		2202254,	2SC4467-Y,	U16	1A472509-1Y	NAAF-4909-1,Center and rear amplifier pc board ass'y <D>
22	27190524	KGLS-14RF,Holder		2202256,	2SC4467-P,		1A472509-1AY	NAAF-4909-1A,Center and rear amplifier pc board ass'y <P/W>
23	27190062	KGLS-12S,Holder		2202502 or	2SC3181N-R or			
32	801433	3SMS8W.SW+14B(BC),Special screw		2202503	2SC3181N-O,Transistors			
33	834430088	3TTS+8B(BC),Self-tapping screw	Q822	2202373,	2SC4466-O,			
34	833430080	3TTP+8P(BC),Self-tapping screw		2202374,	2SC4466-Y,			
35	830440089	4TTC+8B(BC),Self-tapping screw		2202375,	2SC4466-P,			
36	831130088	3TTW+8B,Self-tapping screw		2202352 or	2SC3180N-R or			
37	834430108	3TTS+10B(BC),Self-tapping screw		2202353	2SC3180N-O,Transistors			
39	82143006	3P+6FN(BC),Pan head screw	Q823	2202243,	2SA1694-O,			
42	28184476BY	Top cover		2202244,	2SA1694-Y,			
44	28140265	Cushion		2202246,	2SA1694-P,			
46	28140546	Cushion		2202492 or	2SA1264N-R or			
47	27170302Y	Bottom panel		2202493	2SA1264N-O,Transistors			
51	27175251AY	Leg	Q824	2202363,	2SA1693-O,			
61	1A472121Y	Front panel ass'y		2202364,	2SA1693-Y,			
62	8910301	CS-3, Ring CS		2202365,	2SA1693-P,			
63	28191673Y	Clear plate		2202342 or	2SA1263N-R or			
64	28198782Y	Facet		2202343	2SA1263N-O,Transistors			
67	28135199	Badge	T901	2300983AY	⚠ NPT-1196D,Power transformer <D>			
68	28125255A	End cap L		2300984Y	⚠ NPT-1196P,Power transformer <P>			
69	28125256A	End cap R		2300985Y	⚠ NPT-1196DG,Power transformer <W>			
71	28324933A	Knob VOLUME	U1	1A472592-1Y	NAAR-4892-1,Main circuit pc board ass'y <D>			
72	28324845B	Knob LEVEL		1A472592-1AY	NAAR-4892-1A,Main circuit pc board ass'y <P/W>			
F901	252166Y	⚠ 6.3A-UL/T237,Fuse <D/W>	U2	1A472593-1Y	NAETC-4893-1,Power supply circuit pc board ass'y <D>			
F902	252076	⚠ 3.15A-SE-EAK,Fuse <P/W>		1A472593-1AY	NAETC-4893-1A,Power supply circuit pc board ass'y <P/W>			
F903	252075	⚠ 2.5A-SE-EAK,Fuse <P>	U5	1A472597-1Y	NADIS-4897-1,Display circuit pc board ass'y <D>			
F921,F922	252166Y	⚠ 6.3A-UL/T237,Fuse <D>		1A472597-1AY	NADIS-4897-1A,Display circuit pc board ass'y <P>			
	252079	⚠ 6.3A-SE-EAK,Fuse <P/W>		1A472597-1BY	NADIS-4897-1B,Display circuit pc board ass'y <W>			
				1A472597-1CY	NADIS-4897-1C,Display circuit pc board ass'y <C>			

NOTE: THE COMPONENTS IDENTIFIED BY MARK ⚠ ARE CRITICAL FOR RISK OF FIRE AND ELECTRIC SHOCK. REPLACE ONLY WITH PART NUMBER SPECIFIED.

EXPLODED VIEW

MODEL TX-V940/TX-V940RDS

TX-V940/TX-V940RDS

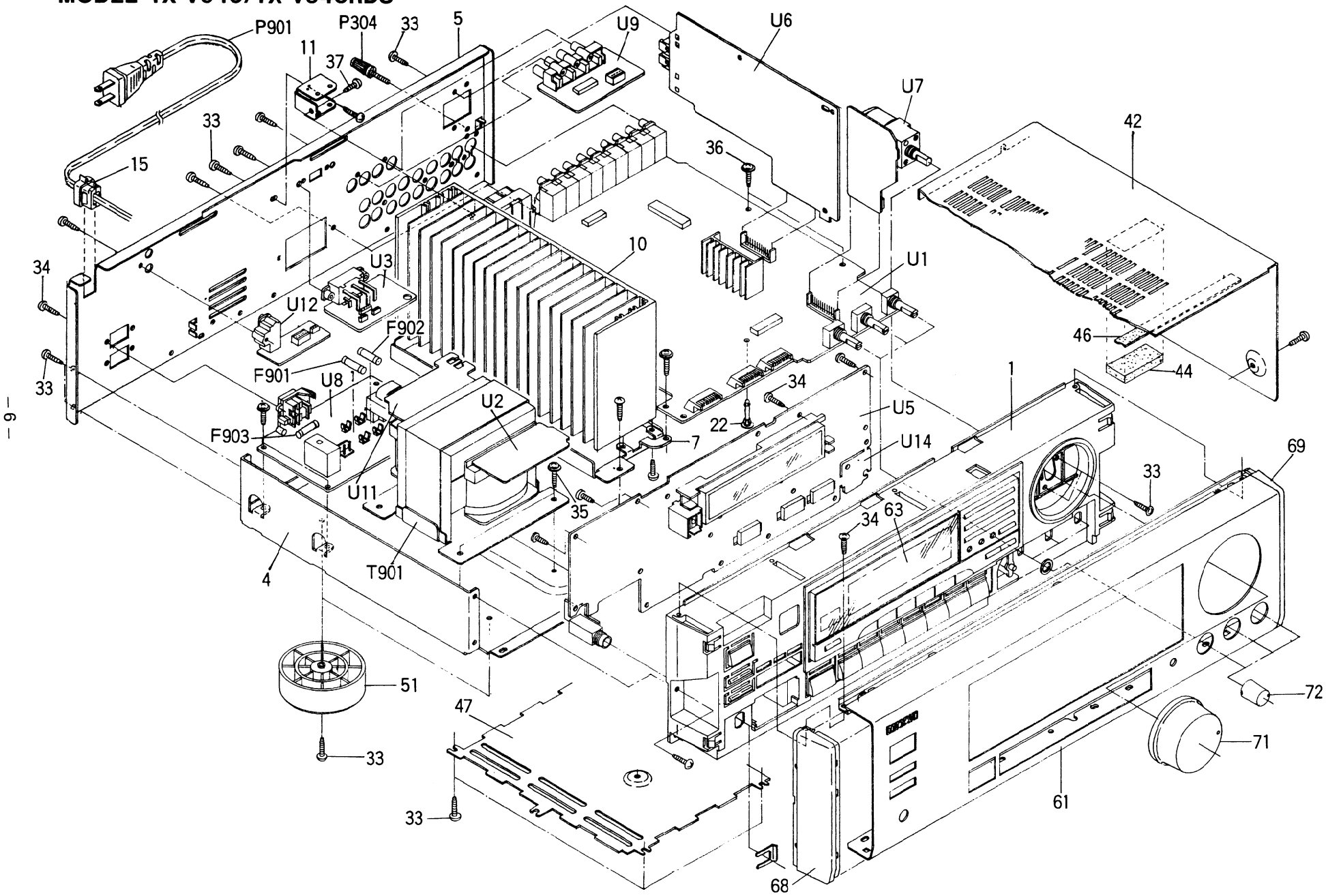

PARTS LIST

REF. NO.	PART NO.	DESCRIPTION	REF. NO.	PART NO.	DESCRIPTION
1	27110792Y	Front bracket <D/W>	P304	25060044	Terminal
	27110795Y	Front bracket <P>	P901	253192HIT	⚠ AS-UC-6#18,Power supply cord <D>
2	28324929Y	Knob CLA		253172 or	⚠ AS-CEE-2,
3	28175209Y	Isolating plate		253092-1A	Power supply cord <P/W>
4	27100278AY	Chassis	Q521,Q522	2201653,	2SC3856-O,
5	27121817Y	Rear panel <D>		2201654 or	2SC3856-Y or
	27121838AY	Rear panel <P>		2201655	2SC3856-P,Transistors
	27121820AY	Rear panel <W>	Q523,Q524	2201663,	2SA1492-O,
7	27130727Y	Bracket H		2201664 or	2SA1492-Y or
8	27270212Y	Spacer <P/W>		2201665	2SA1492-P,Transistors
10	27160330AY	Radiator	T901	2300975AY	⚠ NPT-1197D,Power transformer <D>
11	27141623Y	Retainer H		2300976Y	⚠ NPT-1194P,Power transformer <P>
15	27300750	⚠ Bushing cord		2300977Y	⚠ NPT-1194DG,Power transformer <W>
22	27190524	KGLS-14RF,Holder	U1	1A468592-3Y	NAAR-4892-3,Main circuit pc board ass'y <D>
32	801433	3SMS8W,SW+14B(BC),Special screw		1A468592-3AY	NAAR-4892-3A,Main circuit pc board ass'y <P/W>
33	834430088	3TTS+8B(BC),Self-tapping screw	U2	1A468593-3Y	NAETC-4893-3,Power supply circuit pc board ass'y <D>
34	833430080	3TTP+8P(BC),Self-tapping screw		1A468593-3AY	NAETC-4893-3A,Power supply circuit pc board ass'y <P/W>
35	830440089	4TTC+8B(BC),Self-tapping screw	U3	1A468594-3Y	NASW-4894-3,Switch pc board ass'y <D>
36	831130088	3TTW+8B,Self-tapping screw	U5	1A468597-3Y	NADIS-4897-3,Display circuit pc board ass'y <D>
37	834430108	3TTS+10B(BC),Self-tapping screw		1A476597-3CY	NADIS-4897-3C,Display circuit pc board ass'y <P>
42	28184476BY	Top cover		1A468597-3BY	NADIS-4897-3B,Display circuit pc board ass'y <W>
44	28140265	Cushion	U6	1A468598-3Y	NARF-4898-3,Tuner circuit pc board ass'y <D>
46	28140546	Cushion		1A476598-3CY	NARF-4898-3C,Tuner circuit pc board ass'y <P>
47	27170302Y	Bottom panel		1A468598-3BY	NARF-4898-3B,Tuner circuit pc board ass'y <W>
51	27175251AY	Leg	U7	1A468599-3Y	NAAF-4899-3,Volume circuit pc board ass'y
61	1A468121Y	Front panel ass'y <D/W>	U8	1A468500-3Y	NAPS-4900-3,Power supply circuit pc board ass'y <D>
	1A476121Y	Front panel ass'y <P>		1A468500-3AY	NAPS-4900-3A,Power supply circuit pc board ass'y <P>
62	8910301	CS-3, Ring CS		1A468500-3BY	NAPS-4900-3B,Power supply circuit pc board ass'y <W>
63	28191673Y	Clear plate	U9	1A468501-3Y	NAETC-4901-3,Video circuit pc board ass'y
64	28198782Y	Facet	U11	1A468503-3Y	NAETC-4903-3,Primary circuit pc board ass'y
67	28135199	Badge	U12	1A468504-3Y	NAETC-4904-3,RI terminal pc board ass'y <D>
68	28125255A	End cap L		1A468504-3BY	NAETC-4904-3B,RI terminal pc board ass'y <P/W>
69	28125256A	End cap R	U13	1A468505-3Y	NAETC-4905-3,Headphone terminal pc board ass'y
71	28324932B	Knob VOLUME	U14	1A468506-3Y	NASW-4906-3,Loudness switch pc board ass'y
72	28324845B	Knob LEVEL			
F901	252166Y	⚠ 6.3A-UL/T237,Fuse <D/W>			
F902	252076	⚠ 3.15A-SE-EAK,Fuse <P/W>			
F903	252075	⚠ 2.5A-SE-EAK,Fuse <P>			

NOTE: <D>:120V model only
 <P>:230V model only (TX-V940RDS only)
 <W>:Worldwide model only

NOTE: THE COMPONENTS IDENTIFIED BY MARK ⚠ ARE CRITICAL FOR RISK OF FIRE AND ELECTRIC SHOCK. REPLACE ONLY WITH PART NUMBER SPECIFIED.

BLOCK DIAGRAM

TUNER SECTION

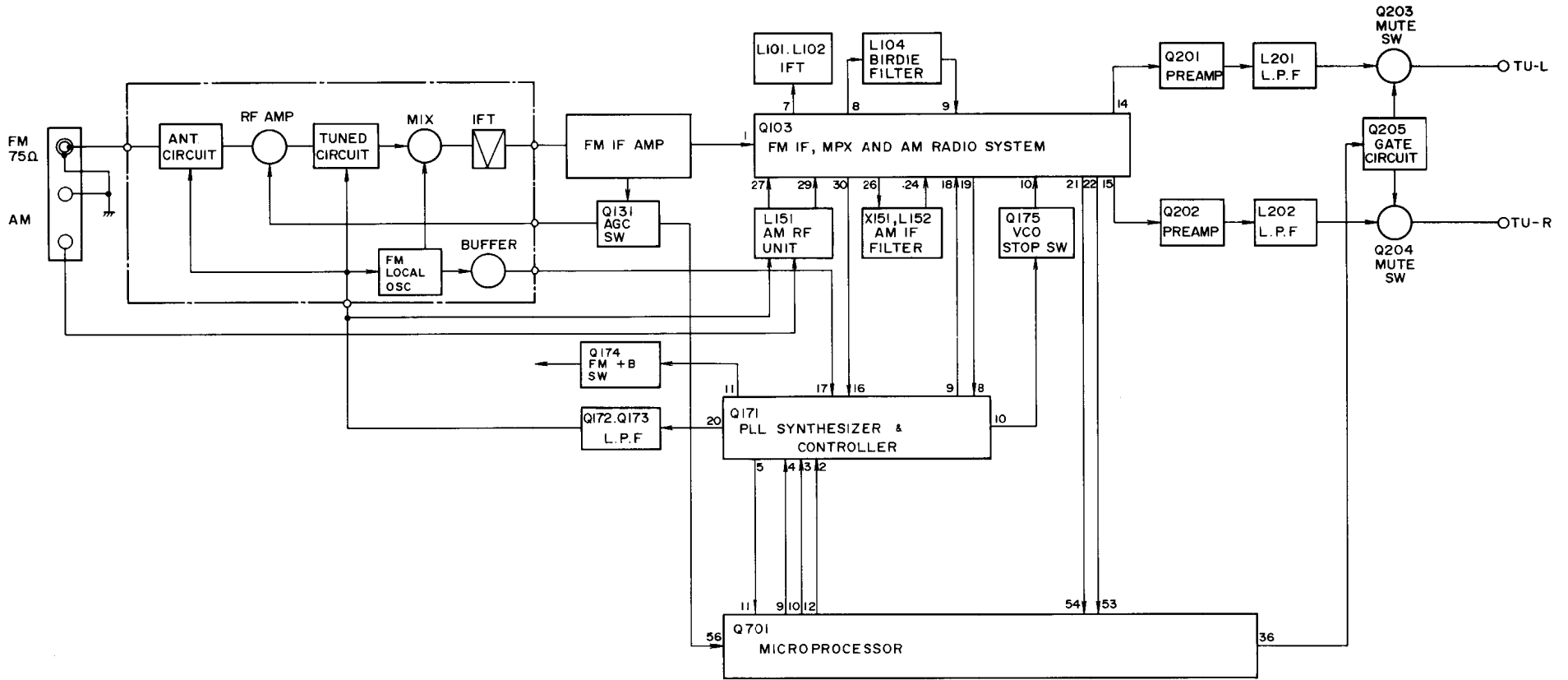

TX-V940RDS

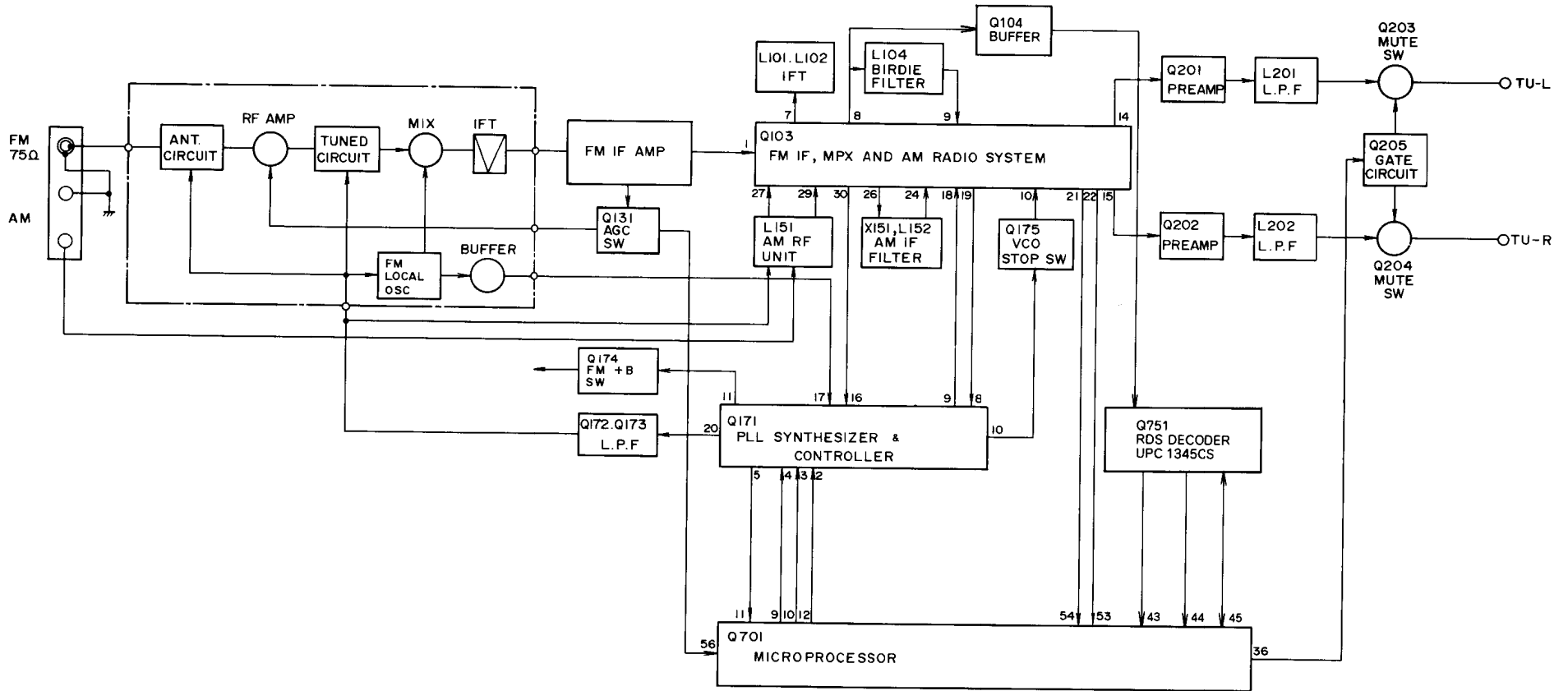

BLOCK DIAGRAM AMPLIFIER SECTION MODEL TX-SV414PRO

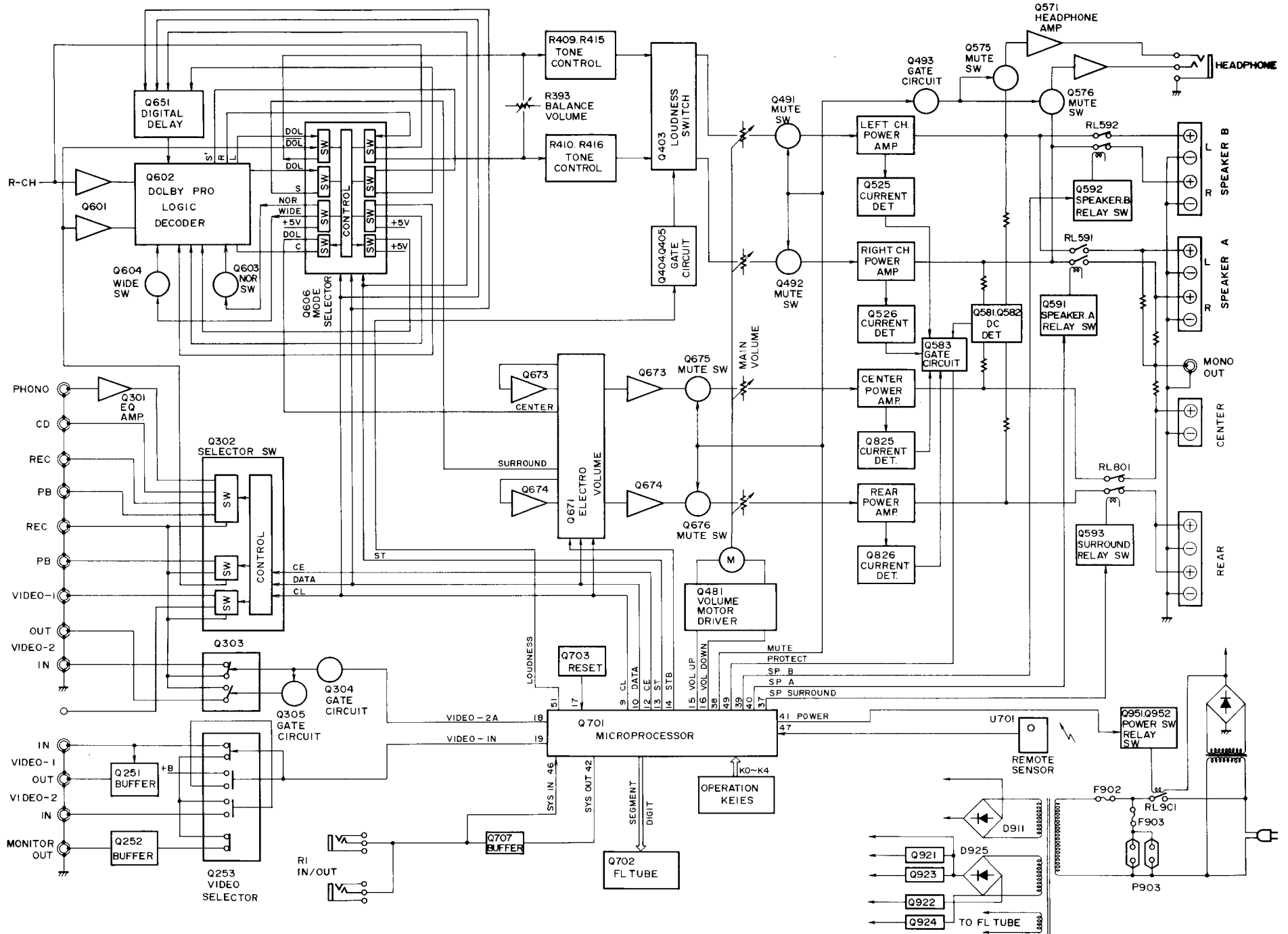

TX-V940/TX-V940RDS

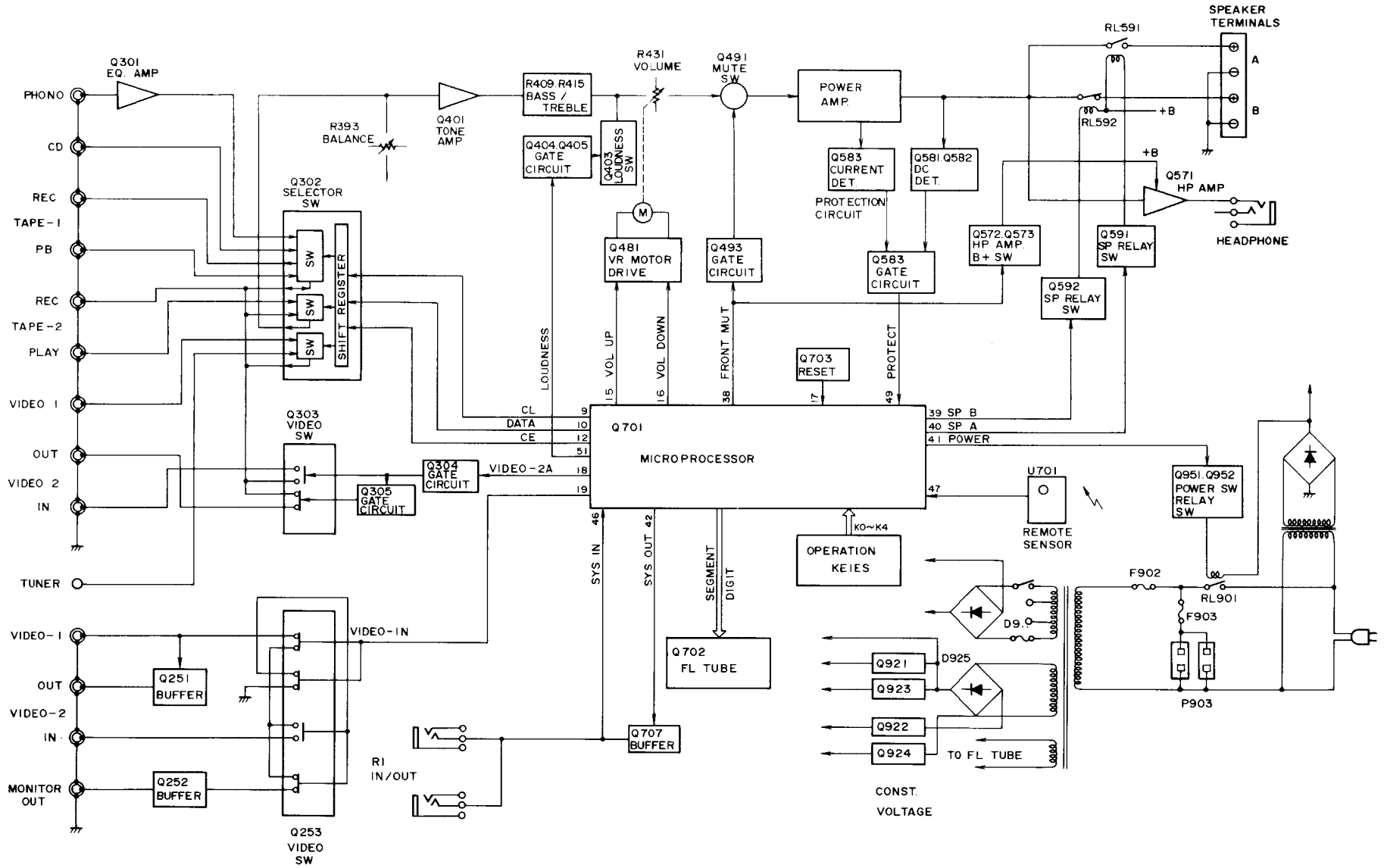

MICROPROCESSOR CONNECTION DIAGRAM

TX-V940/TX-V940RDS
TX-SV414PRO

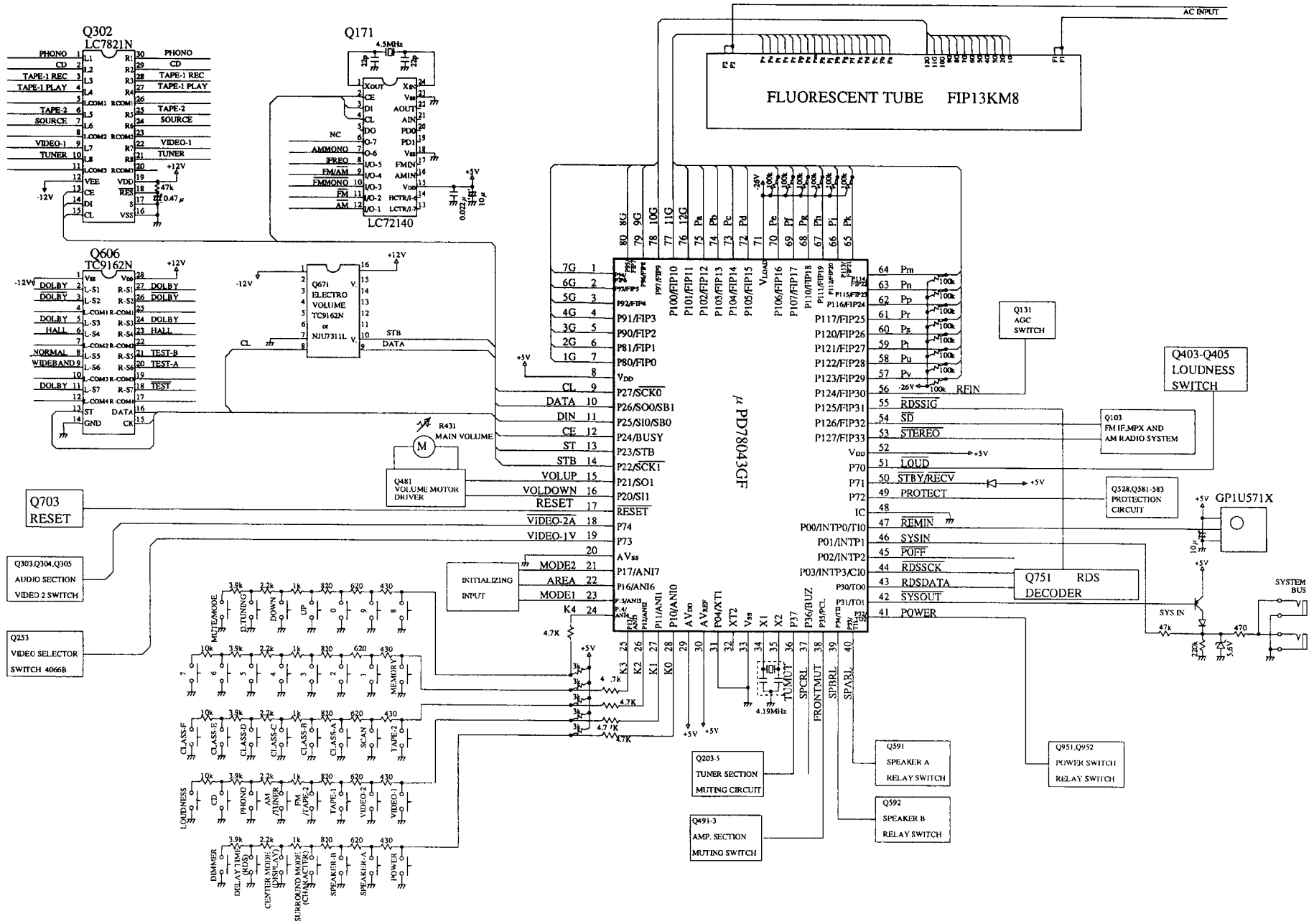

TERMINAL DESCRIPTION

Pin No.	Function	Description
1~7	7G~1G	Grid output terminals Active"H"
8	VDD	Positive power supply terminal (+5V)
9	CL	Output terminal for CL-terminal of LC7821N , CK-terminal of TC9162N , CL-terminal of LC72140 , CK-terminal of TC9213P and SCK-terminal of M65830P
10	DATA	Output terminal for DI-terminal of LC7821N , DATA-terminal of TC9162N , DI-terminal of LC72140 , DATA-terminal of TC9213P and DATA-terminal of M65830P
11	DIN	Input terminal for DO-terminal of LC72140
12	CE	Output terminal for CE-terminal of LC7821N and LC72140
13	STB	Output terminal for ST-terminal of TC9162N , STB-terminal of TC9213P and REQ-terminal of M65830P.
14	RDSSCK	Input terminal for CLK OUT-terminal of RDS decoder μ PC1346CS
15	VOLUP	Volume control output terminal
16	VOLDOWN	Refer to table 1
17	RESET	Input terminal for System Reset
18	VIDEO-2A	Output terminal for changing Audio Signal of VIDEO-2
19	VIDEO-1V	Output terminal for changing Visual Signal of VIDEO-1
20	AVSS	Grand terminal for A/D converter
21	MODE2	Initial setting Input terminal for changing AM stereo function
22	AREA	Initial setting(BAND0,BAND1,AM10K) input terminal for changing frequency range
23	MODE	Initial setting input terminal for surround function
24	K4	Key input terminal.
25	K3	Key input terminal.
26	K2	Key input terminal.
27	K1	Key input terminal.
28	K0	Key input terminal.
29	AVDD	Analog positive power terminal (+5V) for A/D converter
30	AVREF	Reference voltage input terminal for A/D converter
31	XT1	Crystal connection terminal for resonator of sub system clock
32	XT2	Not used.
33	VSS	Ground Terminal
34	X1	Connect the ceramic resonator 4.19MHz.
35	X2	Resonator connection terminal for resonator of main system clock
36	TUMUT	Muting output terminal for tuner
37	SURMUT	Muting output terminal for center and rear amplifiers
38	FRONTMUT	Muting output terminal for front amplifier
39	SPBRL	Control output terminal for speaker relay B

Pin No.	Function	Description
40	SPARL	Control output terminal for speaker relay A
41	POWER	Power source control output terminal
42	SYSOUT	System code output terminal
43	RDSDATA	Input terminal for DATA OUT-terminal of μ PC1346CS
44	RDSSCK	Input terminal for SCK-terminal of μ PC1346CS
45	POFF	Detection input terminal for power failure
46	SYSIN	System code input terminal
47	REMIN	Input terminal for signal of remote control
48	IC	Internal connection terminal
49	PROTECT	Detection input terminal for movement of protection circuit
50	STBY/RECV	STAND-BY and RECEIVED indication output terminal
51	LOUD	Control output terminal for Loudness switch
52	VDD	Positive power supply terminal (+5V)
53	STEREO	Detection input terminal for stereo broadcasting
54	SD	Detection input terminal for radio station
55	RDSSIG	Detection input terminal for RDS broadcasting
56	RFIN	RF MODE input terminal
57~70	Pv~Pe	Segment output terminals Active"H"
71	VLOAD	Pull-down resistor connection terminal for control and driver of FIP
72~75	Pd~Pa	Segment output terminals Active"H"
76~80	12G~8G	Grid output terminals Active"H"

Movement	Outputs	
	VOLUP(#15)	VOLDOWN(#16)
Stop	H	H
UP	H	L
DOWN	L	H
POWER OFF	L	L

Table 1

M65830P (Digitai Delay)

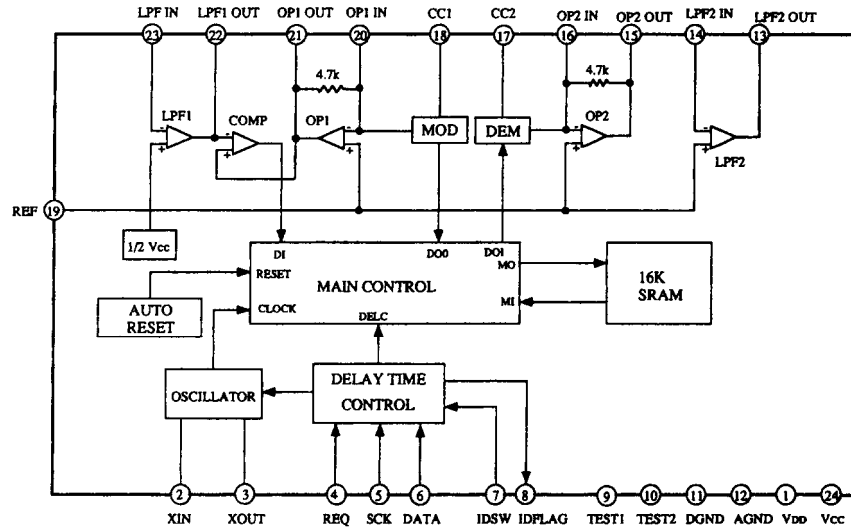

Pin No.	Mark	Function	I/O	Description
1	VDD	Digital power supply	-	
2	XIN	Resonator input	I	Connect the 2MHz ceramic resonator
3	XOUT	Resonator output	O	
4	REQ	Request	I	Data request input
5	SCK	Shift lock	I	Serial data shift clock input
6	DATA	Data	I	Serial data input
7	IDSW	ID switch	I	External input of 4th bit of ID code
8	IDFLAG	ID flag	O	Data input confirmation pulse and serial data output
9	TEST1	Test 1	-	Normal mode when low level
10	TEST2	Test 2	-	Normal mode when low level
11	D GND	Digital ground	-	
12	A GND	Analog ground	-	
13	LPF2 OUT	LPF filter 2 output	O	
14	LPF2 IN	LPF filter 2 input	I	
15	OP2 OUT	Operation amp. 2 output	O	
16	OP2 IN	Operation amp. 2 input	I	
17	CC2	Current control 2	-	Demodulation ADM control
18	CC1	Current control 1	-	Modulation ADM control
19	REF	Reference	-	Analog reference voltage=1/2VCC
20	OP1 IN	Operation amp. 1 input	I	
21	OP1 OUT	Operation amp. 1 output	O	
22	LPF1 OUT	LPF filter 1 output	O	
23	LPF1 IN	LPF filter 1 input	I	
24	VCC	Analog power supply	-	

LC7821N (Analogue switch)

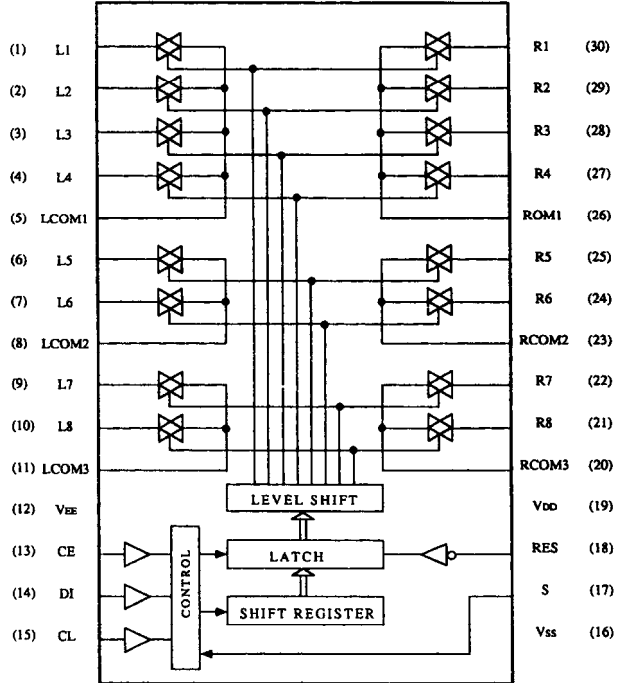

Pin No.	Terminal	Description	Pin No.	Terminal	Description
1	PHONO		16	Vss	Ground terminal.
2	CD		17	S	Selector terminal
3	TAPE 1 REC		18	RES	Reset terminal.
4	TAPE 1 PB	Input/output terminals of audio signal of left channel.	19	VDD	Power supply terminal.(+15V)
5	L COM 1		20	R COM 3	Input/output terminals of audio signal of right channel.
6	MONITOR		21	TUNER	
7	SOURCE		22	VIDEO 1	
8	L COM 2		23	R COM 2	
9	VIDEO 1	24	SOURCE		
10	TUNER	Control to the inside analogue switch at the serial data.	25	MONITOR	
11	L COM 3		26	R COM 1	
12	Vss		Negative power supply terminal. (-15V)	27	TAPE 1 PB
13	CE		Chip enable terminal. Connect the terminal SEL of microprocessor.	28	TAPE 1 REC
14	DI		Serial data input terminal. Connect the terminal DATA of microprocessor.	29	CD
15	CL	Serial clock input terminal. Connect the terminal CL of microprocessor	30	PHONO	

TA7291S (Volume driver)

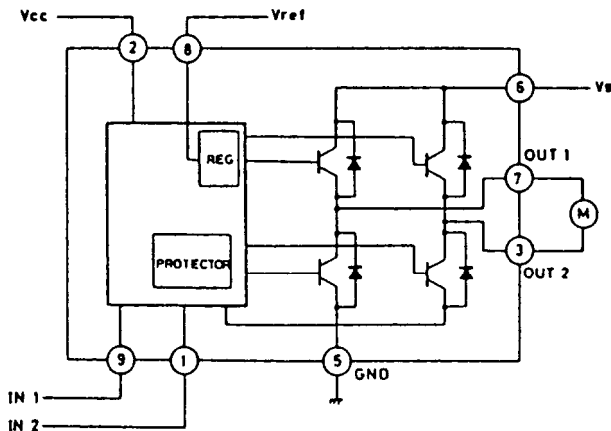

INPUT		OUTPUT		MODE
IN 1	IN 2	OUT 1	OUT 2	
0	0	∞	∞	STOP
1	0	H	L	CW/CCW
0	1	L	H	CCW/CW
1	1	L	L	BRAKE

CCW: Counter clockwise direction
CW: Clockwise direction

LA1851N (AM, FM IF and MPX)

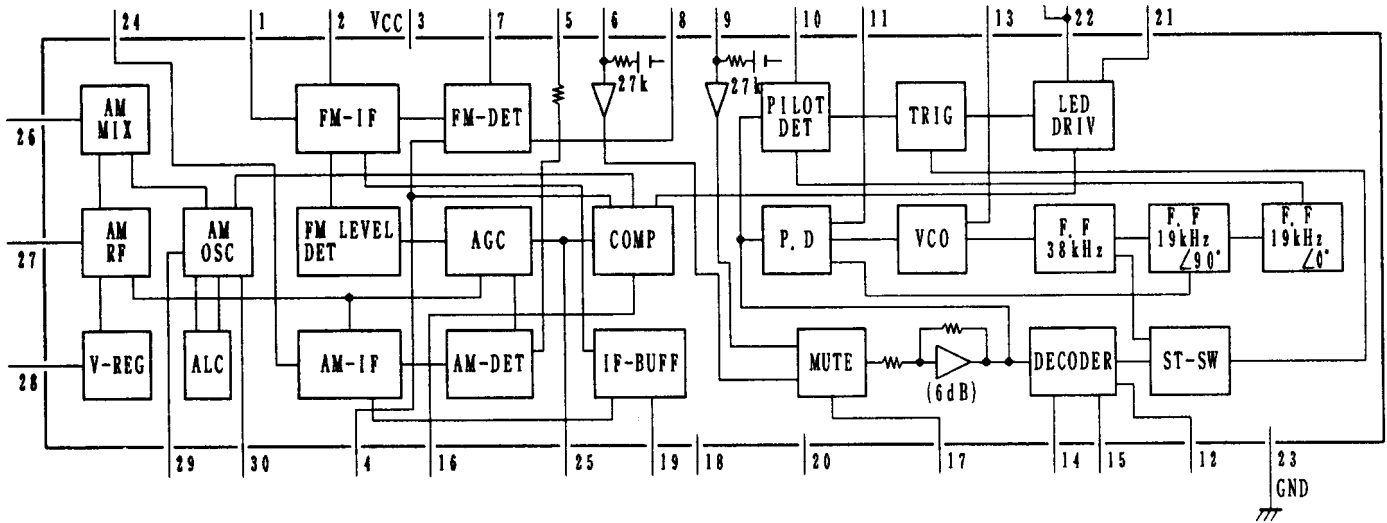

LC72140 (PLL Frequency Synthesized LSI)

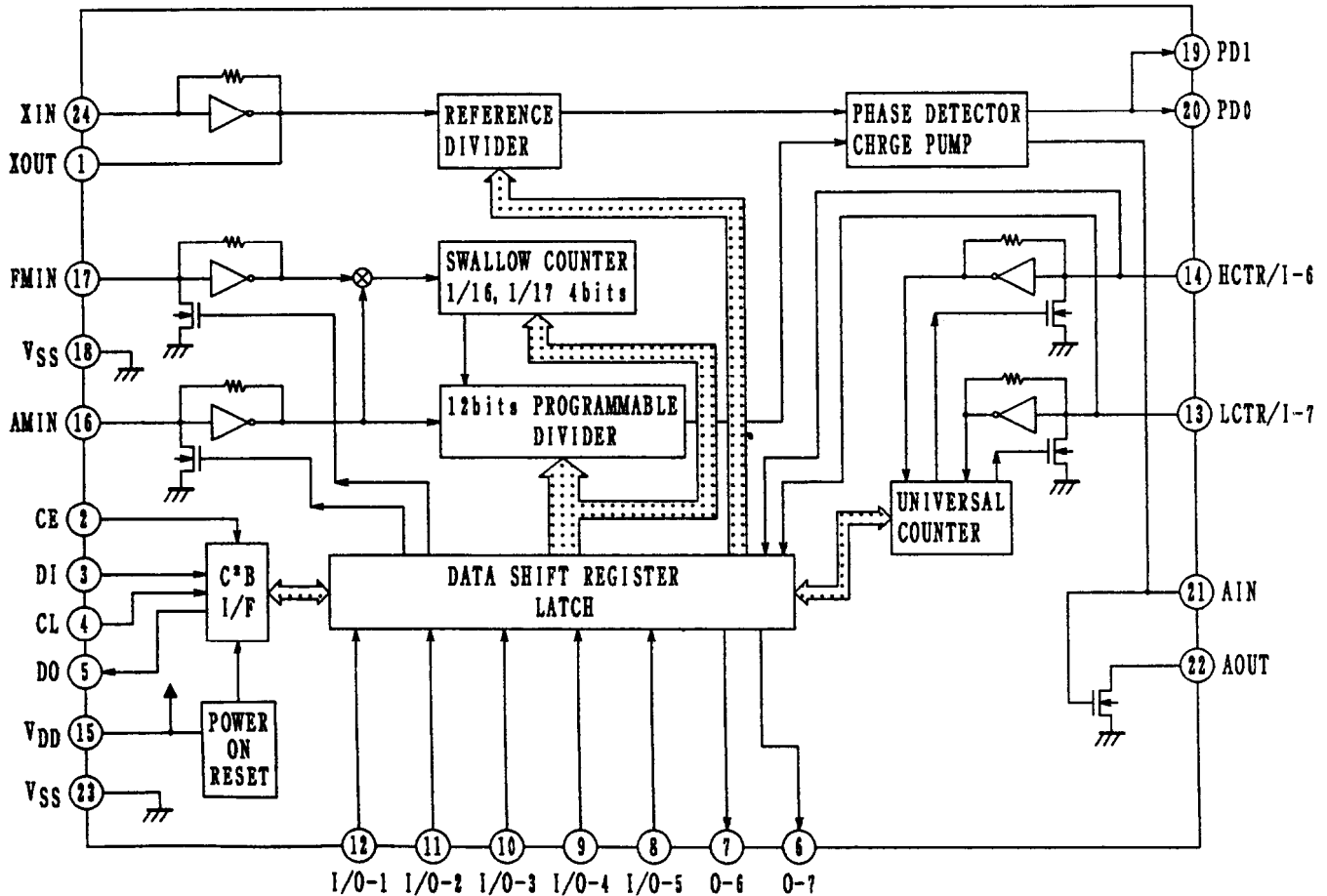

FL TUBE

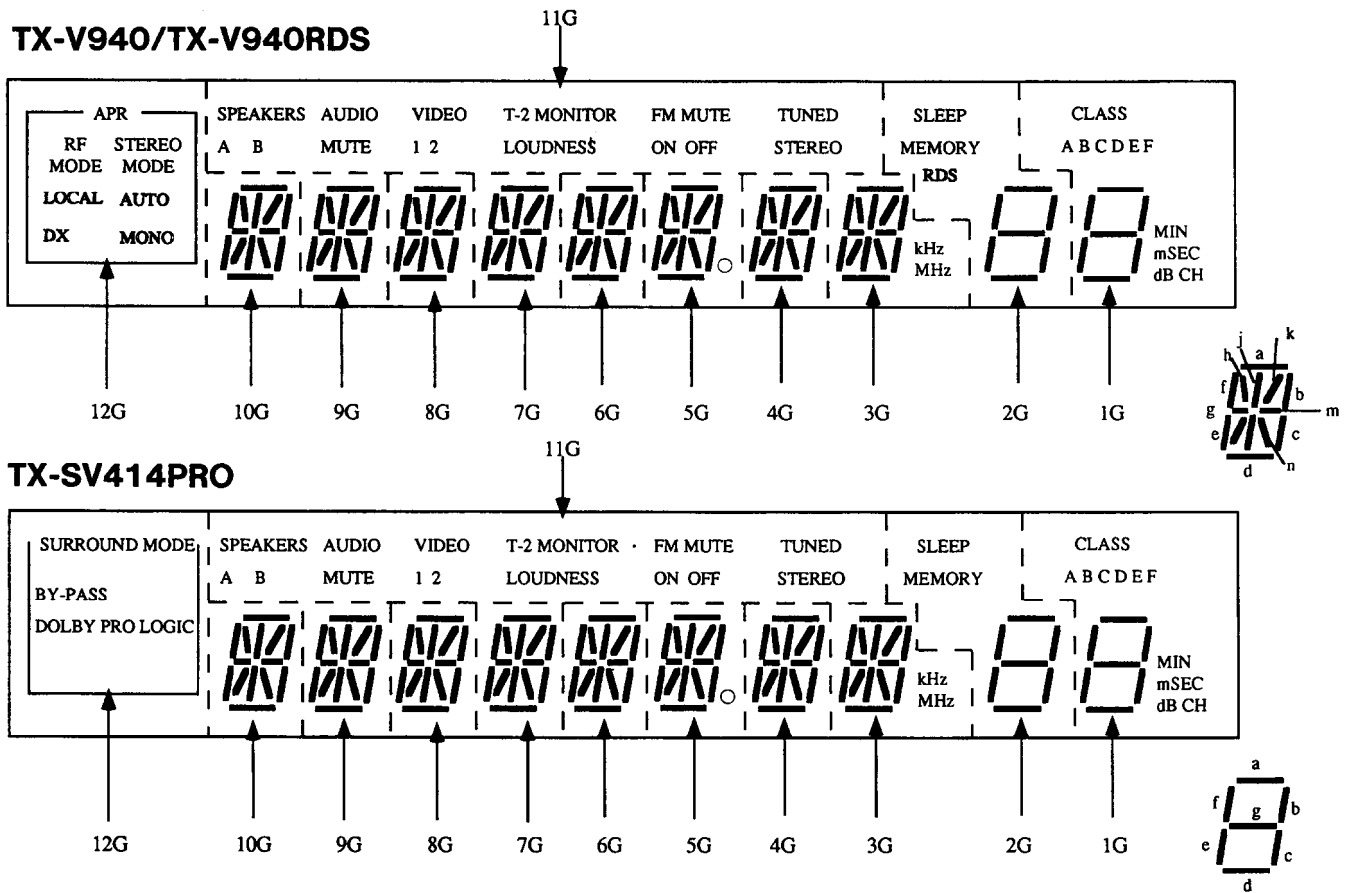

TERMINAL NO.	1	2	3	4	5	6	7	8	9	10	11	12
ELECTRODE	F1	F1	NP	NP	NP	Pv	Pu	Pt	Ps	Pr	Pp	Pn
TERMINAL NO.	13	14	15	16	17	18	19	20	21	22	23	24
ELECTRODE	Pm	Pk	Pj	Ph	Pg	Pf	Pe	Pd	Pc	Pb	Pa	NP
TERMINAL NO.	25	26	27	28	29	30	31	32	33	34	35	36
ELECTRODE	NP	NP	NP	12G	11G	10G	9G	8G	7G	6G	5G	4G
TERMINAL NO.	37	38	39	40	41	42	43	44	45	46		
ELECTRODE	3G	2G	1G	NP	NP	NP	NP	NP	F2	F2		

ADJUSTMENT PROCEDURES

Preparation

1. Input

FM mono: 1kHz, 75kHz devi., 60dB/μV

FM stereo: 1kHz, 75kHz devi., 60dB/μV

Pilot signal 19kHz 7.5kHz devi.

AM: 400Hz 30% mod.

2. Outputs

Connect the non-inductive type resistors of 8 ohms to the speaker terminals A unless otherwise noted.

TX-SV414PRO

3. Standard Knob Positions

Master Volume Control	Maximum
Bass Control	Center
Treble Control	Center
Balance Control	Center
Input selector	CD
Tape 2 Monitor.....	OFF
Muting	OFF
Loudness	OFF
Speakers	ON
Dolby Surround.....	OFF
Center Mode	Wide Band
Delay Time.....	20 ms
Center Level	0 dB
Rear Level	0 dB

Idling Current Adjustment

Connect the DC voltmeter to the terminals P521, P522, and P821 (VCT and IID) on the main circuit pc board.

Adjust the trim resistors R537, R538 and R837 so that the indicator of voltmeter becomes $3 \pm 0.5\text{mV}$.

NOTE: Adjust after switching on for 5 minutes.

Set Volume knob to the minimum position.

TX-V940/TX-V940RDS

3. Standard Knob Positions

Master Volume Control	Maximum
Bass Control	Center
Treble Control	Center
Balance Control	Center
Input selector	CD
Tape 2 Monitor.....	OFF
Muting	OFF
Loudness	OFF
Speakers	A

Idling Current Adjustment

Connect the DC voltmeter to the terminals P521, and P522 (VCT and IID) on the main circuit pc board.

Adjust the trim resistors R537, and R538 so that the indicator of voltmeter becomes $3 \pm 0.5\text{mV}$.

NOTE: Adjust after switching on for 5 minutes.

Set Volume knob to the minimum position.

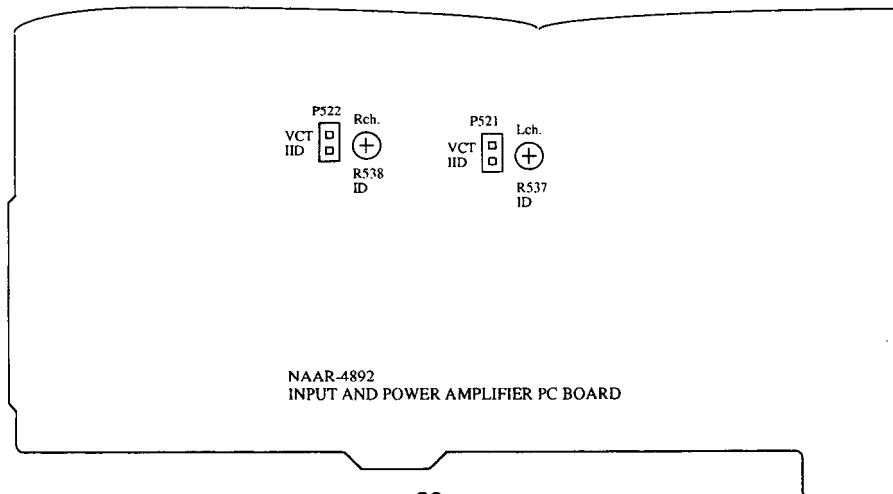

Set the unit to the test mode.

1. Press and hold down the CD button, then press the Power button.
2. "TEST-" is displayed on the display.
3. While "TEST-" is displayed, press the FM key.

FM ADJUSTMENT

Item	Step	Connection of instrument	FM SG output	Stereo modulator output	Tuning frequency	Output indicator	Adjustment point	Adjust for	Remarks
FM IF/RF	1	Fig.1	99.0MHz 1kHz 75kHz devi. 65dBf(60dB)	—	99.0MHz	DC voltmeter	L101	0±20mV	FM MUTE/MODE switch:ON/STEREO Repeat the steps 1 and 3 until no further adjustment is necessary.
	AC voltmeter					IFT on the front end	Maximum		
	Distortion analyzer					L102	Minimum		
Stereo Distortion		Fig.2	99.0MHz Ext. mod.65dBf(60dB)	Channel L or R 1kHz	99.0MHz	Distortion analyzer	IFT on the front end	Minimum	Don't turn more than ±180°
Stereo Separation	1	Fig.2	99.0MHz Ext. mod. 65dBf(60dB)	Channel L 1kHz	99.0MHz	Channel R AC voltmeter	R202	Minimum	Maximum and same separation
	2			Channel R 1kHz		Channel L AC voltmeter		Minimum	
Muting Level		Fig.2	99.0MHz 21.2dBf(16dB) <P/W models> 23.2dBf(18dB) <D model>	—	99.0MHz	Oscilloscope or TUNED indicator	R101	Signal output or light on	
RDS		Fig.3	99.0MHz Ext. mod.40dB	RDS data or 57kHz 3% devi.	99.0MHz	Oscilloscope	R786	Maximum	TX-V940RDS only

AM ADJUSTMENT

120V model

Step	AM SG output	Tuning Frequency	Output Indicator	Adjustment point	Adjust for
1		530kHz	Digital DC voltmeter	OSC coil on RF block L151	1.3±0.1V
2	600kHz 400Hz 30% mod. 60dB/m	600kHz	AC voltmeter	RF coil on RF block L151	Maximum
3	990kHz 400Hz 30% mod. 60dB/m	990kHz	AC voltmeter	L152	Maximum

Reference Specification
 FM tuned voltage:87.9MHz~107.9MHz
 More than 1.3V~Less than 10V
 AM tuned voltage:530kHz~1710kHz
 1.3±0.2V~Less than 9.0V

230V and Worldwilde models

Step	AM SG output	Tuning Frequency	Output Indicator	Adjustment point	Adjust for
1		522kHz or 531kHz	Digital DC voltmeter	OSC coil on RF block L151	1.3±0.1V
2	603kHz 400Hz 30% mod. 60dB/m	603kHz	AC voltmeter	RF coil on RF block L151	Maximum
3	999kHz 400Hz 30% mod. 60dB/m	999kHz	AC voltmeter	L152	Maximum

Reference Specification
 FM tuned voltage:87.5MHz~108.0MHz
 More than 1.3V~Less than 10V
 AM tuned voltage:522kHz~1611kHz
 1.3±0.2V~Less than 9.0V
 (230V model)
 AM tuned voltage:531kHz~1602kHz
 1.3±0.2V~Less than 9.0V
 (Worldwilde model)

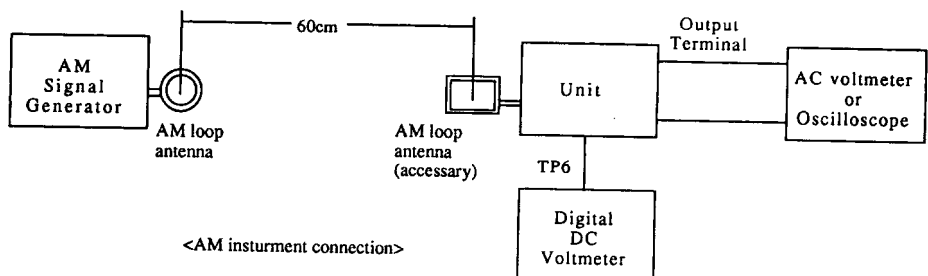

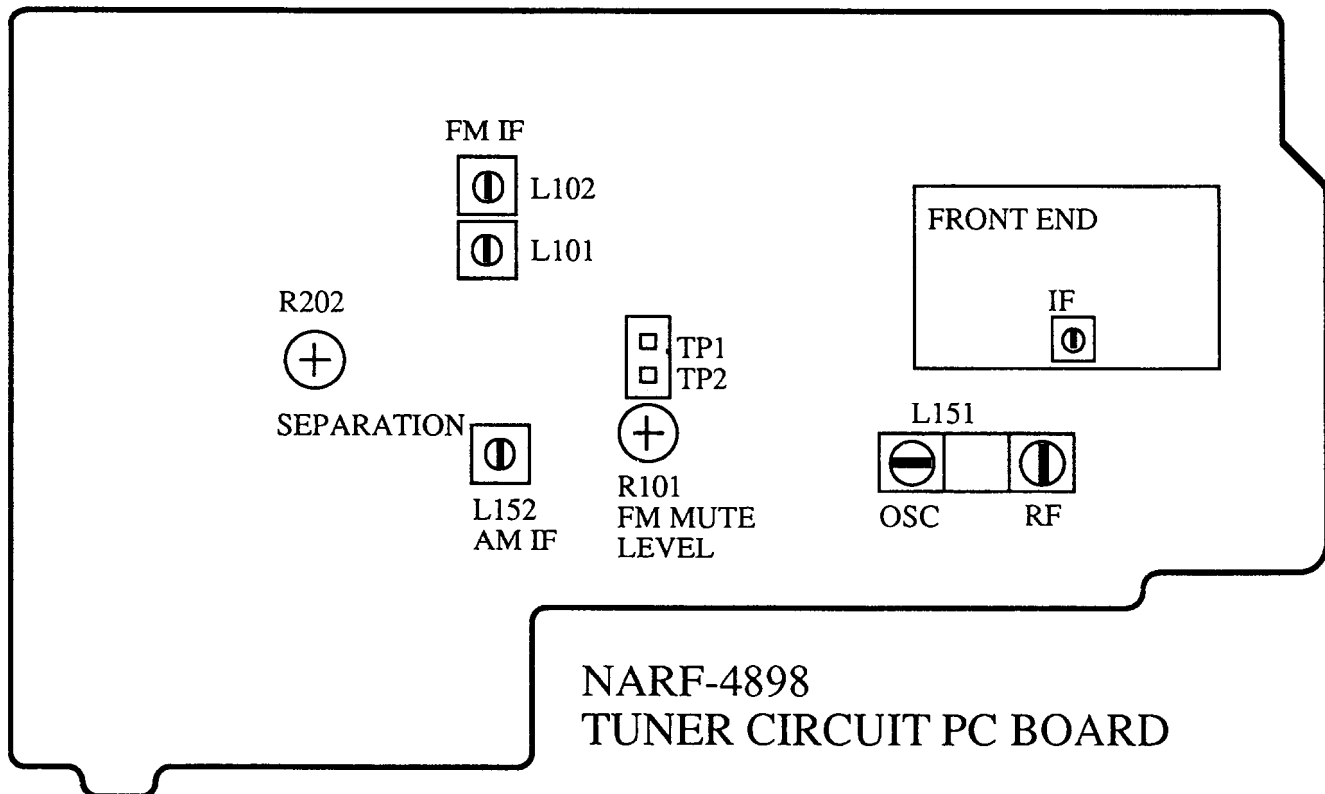
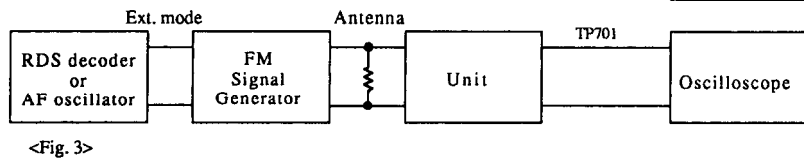
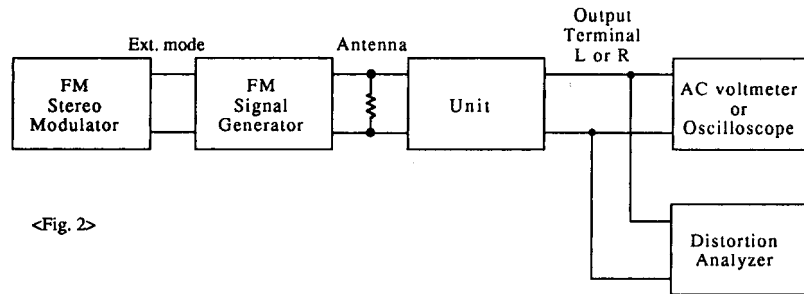
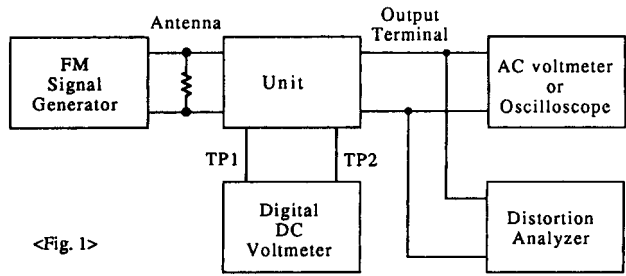

PRINTED CIRCUIT BOARD-PARTS LIST

MODEL TX-V940/TX-V940RDS

MAIN CIRCUIT PC BOARD (NAAR-4892-3/3A)

CIRCUIT NO.	PART NO.	DESCRIPTION	CIRCUIT NO.	PART NO.	DESCRIPTION
	ICs			Diodes	
Q301	222502	NJM4558D-X	D507,D508	223222,	WG713A,
Q302	22240280	LC7821N	D571,D572	223205 or	1SS270A or
Q303,Q403	22240025	LC4966	D591,D592	223163	1SS133
Q401,Q402	22240247	BA15218N	D911	22380038	RBV602
Q481	22240239	TA7291S	D921-D924	22380035 or	GP104003E or
Q571	22240752	NJM4556L	D926-D928	22380046	AM01Z
Q921	222780125NEC	78M12HF	D929	224453304	MTZ33D
Q922	222790125	79M12HF	D930,D931	223222,	WG713A,
Q923	222780565JRC	78M56		223205 or	1SS270A or
	Transistors			223163	1SS133
Q304,Q404	2213510 or	DTA114ES or		Coils	
Q493	2214350	RN2202	L501,L502	231176S	S-1.3C
Q305,Q405	221282 or	DTC144ES or		Capacitors	
Q572	2213560	RN1204	C303,C304	354741009	10 μ F,16V,Elect.
Q491,Q492	2213631 or	RN1241-A or	C307,C308	354721019	100 μ F,6.3V,Elect.
Q575,Q576	2213632	RN1241-B	C309,C310	374726224	6200pF \pm 5%,50V,Plastic
Q501-Q504	2211732 or	2SC1845-F or	C311,C312	374721824	1800pF \pm 5%,50V,Plastic
Q507,Q508	2211733	2SC1845-E	C313-C316	354741009	10 μ F,16V,Elect.
Q511,Q512	2211353 or	2SA949-O or	C391,C392	374721015	100pF \pm 10%,50V,Plastic
	2211354	2SA949-Y	C401,C402	354741009	10 μ F,16V,Elect.
Q513,Q514	2211633 or	2SC2229-O or	C407-C412	354741009	10 μ F,16V,Elect.
	2211634	2SC2229-Y	C413,C414	374721534	0.015 μ F \pm 5%,50V,Plastic
Q515,Q516	2213284 or	2SC1740S-R or	C417,C418	374721534	0.015 μ F \pm 5%,50V,Plastic
	2212115	2SC2458-GR	C421,C422	374724734	0.047 μ F \pm 5%,50V,Plastic
Q517,Q518	2202034 or	2SD1763A-D or	C481,C514	354721019	100 μ F,6.3V,Elect.
	2202035	2SD1763A-E	C491	354741009	10 μ F,16V,Elect.
Q519,Q520	2202024 or	2SB1186A-D or	C501,C502	354741009	10 μ F,16V,Elect.
	2202025	2SB1186A-E	C503,C504	374721015	100pF \pm 10%,50V,Plastic
Q521,Q522	2201653,	* 2SC3856-O,	C507,C508	354742219	220 μ F,16V,Elect.
	2201654 or	* 2SC3856-Y or	C513,C514	354722219	220 μ F,6.3V,Elect.
	2201655	* 2SC3856-P	C521,C522	354772209	22 μ F,63V,Elect.
Q523,Q524	2201663,	* 2SA1492-O,	C527,C528	374724734	0.047 μ F \pm 5%,50V,Plastic
	2201664 or	* 2SA1492-Y or	C567,C568	354700109	1 μ F,160V,Elect.
	2201665	* 2SA1492-P	C570	354791019	100 μ F,100V,Elect. <D>
Q525,Q526	2211633 or	2SC2229-O or		354771019	100 μ F,63V,Elect. <P/W>
	2211634	2SC2229-Y <D>	C571-C573	354741009	10 μ F,16V,Elect.
Q525,Q526	2211732 or	2SC1845-F or	C581	354721019	100 μ F,6.3V,Elect.
	2211733	2SC1845-E <P/W>	C915,C916	3504265	6800 μ F,71V,Elect. <D>
Q573	2211163 or	2SC2120-O or		3504266 or	# 6800 μ F,56V or
	2211164	2SC2120-Y		3504267	# 6800 μ F,56V,Elect. <P/W>
Q581,Q582	2211732 or	2SC1845-F or	C923	354753329	3300 μ F,25V,Elect.
	2211733	2SC1845-E	C924	354764719	470 μ F,35V,Elect.
Q583	2211792 or	2SA992-F or	C927,C928	354741009	10 μ F,16V,Elect.
	2211793	2SA992-E	C931	354741009	10 μ F,16V,Elect.
Q591,Q592	2213640 or	DTC123JS or	C932	354761019	100 μ F,35V,Elect.
	2214660	RN1205	C933	354781019	100 μ F,50V,Elect.
Q924	2211455	2SA1015-GR	C936-C938	354741009	10 μ F,16V,Elect.

CAUTION: Replacement for transistor of mark *, if necessary, must be made from the same beta group (H α) as the original type.

CAUTIONS: Replacement for capacitor of mark # must be made the same sort capacitor.

CIRCUIT NO.	PART NO.	DESCRIPTION	CIRCUIT NO.	PART NO.	DESCRIPTION
	Resistors			Transistors	
R393	5104225	N11RGLC250KWT22Z, Balance	Q703	221282 or	DTC144ES or
R409	5104230	N14RLC100KWT22Z,Bass		2213560	RN1204
R415	5104230	N14RLC100KWT22Z,Treble	Q704-Q706	2213284 or	2SC1740S-R or
R533,R534	443522704	27 ohm,1/2W,Metal oxide		2212115	2SC2458-GR
R535,R536	443521014	100 ohm,1/2W,Metal oxide	Q707	2213510 or	DTA114ES or
R537,R538	5210259	N06HR 2KBC,Trim		2214350	RN2202
R543,R544	443523314	330 ohm,1/2W,Metal oxide		Diodes	
R545,R546	4000132Y	0.22 ohm × 2,5W + 5W,Metal plate	D701,D702	223205 or	1SS270A or
R551,R552	453630824	8.2 ohm,1W,Metal	D704,D705	223163	1SS133
R553,R554	443523924	3.9 kohm,1/2W,Metal oxide	D703	224450913	MTZ9.1C
R567,R568	453530224	2.2 ohm,1/2W,Metal	D706,D707	224450562	MTZ5.6B
R570	443522204	22 ohm,1/2W,Metal oxide	D708	223205 or	1SS270A or
R923	453530224	2.2 ohm,1/2W,Metal	D710-D712	223163	1SS133
R924	453530824	8.2 ohm,1/2W,Metal	D709	225291D	SEL4910D-D,LED
R927,R930	443522204	22 ohm,1/2W,Metal oxide	D751	223205 or	1SS270A or
R933	443524704	47 ohm,1/2W,Metal oxide		223163	1SS133 <P>
	Relaics			Resonator	
RL591,RL592	25065339	NRL-2P5A-DC24-046	X701	3010163	CST4.19MGW,Ceramic
	Plugs		X751	3010203	AF6146CG,X'tal <P>
P211a	25055652	NPLG-14P608		Coils	
P613a	25055651	NPLG-12P607	L701-L703	233454K220	NCH-1452 220K
	Terminals			Capacitors	
P301-P303	25045300	NPJ-6PDBL-159	C701	3000075Y	0.047F,5.5V,Super
P501	25060158	NTM-8PDMN084	C702	375524744	0.47 μ F \pm 5%,50V,Plastic
	Sockets		C703,C709	354721019	100 μ F,6.3V,Elect.
P711a-P713a	25051046	NSCT-10P833	C704	354780109	1 μ F,50V,Elect.
JL261a	25051087	NSCT-3P874	C706,C707	354780109	1 μ F,50V,Elect.
JL912a,JL913a	25051109	NSCT-5P896	C711	354721019	100 μ F,6.3V,Elect.
	POWER SUPPLY CIRCUIT PC BOARD(NAETC-4893-3/3A)		C751	354721019	100 μ F,6.3V,Elect. <P>
CIRCUIT NO.	PART NO.	DESCRIPTION	C753,C754	374724724	4700pF \pm 5%,50V,Plastic <P>
R921,R922	453534794	0.47 ohm,1/2W,Metal resistors	C755,C756	374723324	3300pF \pm 5%,50V,Plastic <P>
	SWITCH PC BOARD (NASW-4894-3)		C757	354780229	2.2 μ F,50V,Elect. <P>
CIRCUIT NO.	PART NO.	DESCRIPTION	C758	374724734	0.047 μ F \pm 5%,50V,Plastic <P>
S911	25065437	NSS-22157P.Slide switch	C759	374722234	0.022 μ F \pm 5%,50V,Plastic <P>
	DISPLAY CIRCUIT PC BOARD (NADIS-4897-3/3A/3C)		C760	374724724	4700pF \pm 5%,50V,Plastic <P>
CIRCUIT NO.	PART NO.	DESCRIPTION	R786	5210265	N06HR50KBC,Trim
	ICs			Switches	
Q701	22240773Y	μ PD78042GF-064 <D/W>	S701-S703	25035652	NPS-111-S604
	22240758Y	μ PD78043GF-071 <P>	S704-S706	25035652	NPS-111-S604 <P>
Q751	22240679	μ PC1346CS <P>	S707-S713	25035652	NPS-111-S604
	FL tube		S715-S737	25035652	NPS-111-S604
Q702	212128Y	FIP13KM8		Plugs	
	Remote control sensor		P711b-P713b	25055659	NPLG-10P615
U701	24130010Y	HC-312		Holder	
				27190937Y	FL tube
				Retainer	
				27141575Y	RI terminal

NOTE: <D>:120 V model only
 <P>:230 V model only
 <W>:Worldwide model only

TUNER CIRCUIT PC BOARD (NARF-4898-3/3B/3C)

CIRCUIT NO.	PART NO.	DESCRIPTION
	Front end	
TU001	240095Y	TFFJ2U316A <D>
	240089	FE415-G11 <P/W>
	ICs	
Q103	22240749Y	LA1851N
Q171	22240750Y	LC72140
	Transistors	
Q101	2210746	2SC945A-P <P/W>
Q102	2211723	2SC1923-O
Q104	2213284 or 2212115	2SC1740S-R or 2SC2458-GR <P>
Q131,Q173	2213284 or	2SC1740S-R or
Q201,Q202	2212115	2SC2458-GR
Q172	2212445	2SK365-GR
Q174,Q175	2213510 or	DTA114ES or
Q205	2214350	RN2202
Q203,Q204	2212794	2SD1468-R
	Diodes	
D131,D132	223191	SD101
D171	224450512	MTZ5.1B
	Resonators	
X171	3010228Y	XTL-4.5M,Crystal
X201	3010227Y	CSB456F15,Ceramic
	Coils and transformers	
L101	233457Y	NFIF-4081
L102	233458Y	NFIF-4082
L103	233454M022	NCH-1452 022M
L104	233383	NMC-6070
L201,L202	233355A	NMC-4059
L151	232163	NMRF-7065
L152	232139	NMIF-4062
	Ceramic filters	
X101	3010071	SFE10.7MA5
X102	3010071	SFE10.7MA5 <P/W>
X103	3010071	SFE10.7MA5 <D>
	3010130	SFE10.7MZ2A <P/W>
X151	3010123	SFZ-450JL
	Capacitors	
C001	354741019	100 μ F,16V,Elect.
C107-C109	354780229	2.2 μ F,50V,Elect.
C110,C171	354741019	100 μ F,16V,Elect.
C132	354742209	22 μ F,16V,Elect.
C133	354784799	0.47 μ F,50V,Elect.
C151	354741009	10 μ F,16V,Elect.
C155,C156	354741009	10 μ F,16V,Elect.
C157	374723324	3300pF \pm 5%,50V,Plastic
C158	374721534	0.015 μ F \pm 5%,50V,Plastic
C159,C180	354721019	100 μ F,6.3V,Elect.
C174	374723334	0.033 μ F \pm 5%,50V,Plastic

CIRCUIT NO.	PART NO.	DESCRIPTION
	Capacitors	
C175	354780229	2.2 μ F,50V,Elect.
C176	374722234	0.022 μ F \pm 5%,50V,Plastic
C177	354782299	0.22 μ F,50V,Elect.
C201,C202	354780109	1 μ F,50V,Elect.
C203	354783399	0.33 μ F,50V,Elect.
C204	354741019	100 μ F,16V,Elect.
C205,C206	374721534	0.015 μ F \pm 5%,50V,Plastic <D>
	374721034	0.01 μ F \pm 5%,50V,Plastic <P>
	374721234	0.012 μ F \pm 5%,50V,Plastic <W>
C207-C210	354741009	10 μ F,16V,Elect. <D>
C213-C216	354741009	10 μ F,16V,Elect. <P/W>
C217	354780229	2.2 μ F,50V,Elect.
	Resistors	
R101	5210263	N06HR 20KBC,Trim
R202	5210259	N06HR2KBC,Trim
	Terminal	
P101	25060160	NTM-4PDML086 <D>
	25060117	NTM-2PDML051 <P/W>
	Socket	
P211b	25050986	NSCT-14P773

VOLUME CIRCUIT PC BOARD (NAAF-4899-3)

CIRCUIT NO.	PART NO.	DESCRIPTION
R431,R432	5104334Y	N16RGL100KBT25F,Variable,Volume
P613b	25050985	NSCT-12P772,Socket

POWER SUPPLY CIRCUIT PC BOARD (NAPS-4900-3/3A/3B)

CIRCUIT NO.	PART NO.	DESCRIPTION
	Transistors	
Q951	221282 or 2213560	DTC144ES or RN1204
Q952	2213650 or 2214680	DTD113ZS or RN1226
	Diodes	
D951-D954	22380035 or 22380046	GP104003E or AM01Z
D955	223222, 223205 or 223163	WG713A, 1SS270A or 1SS133
	Capacitors	
C901	3500065A	Δ DE7150FZ103PAC400V/125V
C952	354742219	220 μ F,16V,Elect.
	Resistors	
R901	431523355	Δ 3.3M Ω ,1/2W,Solid <D>
R951	453530824	8.2 ohm,1/2W,Metal
	Power transformer	
T902	2300670	Δ NPT-1111D <D>
	2300671	Δ NPT-1111P <P>
	2300672	Δ NPT-1111DG <W>

LOUDNESS SWITCH PC BOARD(NASW-4906-3)

CIRCUITNO.	PART NO.	DESCRIPTION	CIRCUIT NO.	PART NO.	DESCRIPTION
	Relay			Socket	
RL901	25065483	△ NRL-1P5A-DC-12-084	S714	25035652	NPS-111-S604
	Fuses				
F901	252166Y	△ 6.3A-UL/T-237 <D/W>			
F902	252076	△ 3.15A-SE-EAK <P/W>			
F903	252075	△ 2.5A-SE-EAK <P>			
	Fuseholders				
F901a	25050065	△ YSH403T <D/W>			
F902a	25050065	△ YSH403T <P/W>			
F903a	25050065	△ YSH403T <P>			
	Plug				
P901a	25055675	NPLG-2P631 <D>			
	Socket				
P902	25051126	△ NSCT-4P913,AC outlet <D>			
	25050410	△ NSCT-2P235,AC outlet <P/W>			
	Switch				
S901	25065437	△ NSS-22157P,Voltage selector <W>			

VIDEO CIRCUIT PC BOARD (NAETC-4901-3)

CIRCUIT NO.	PART NO.	DESCRIPTION
	IC	
Q253	222840661	4066B
	Transistors	
Q251,Q252	2213284 or 2212115	2SC1740S-R or 2SC2458-GR
	Diode	
D251	223222, 223205 or 223163	WG713A, 1SS270A or 1SS133
	Capacitors	
C251,C252	354721019	100 μ F,6.3V,Elect.
C255,C256	354724719	470 μ F,6.3V,Elect.
C257	354721019	100 μ F,6.3V,Elect.
C259	354741019	100 μ F,16V,Elect.
	Terminal	
P251	25045339	NPJ-4PDYE190

RI TERMINAL PC BOARD(NAETC-4904-3/3B)

CIRCUIT NO.	PART NO.	DESCRIPTION
	Terminal	
P961	25045330	NPJ-2PDBL184
	Switch	
S961	25065286	NSS-22112,Band <W>

HEADPHONE TERMINAL PC BOARD(NASW-4905-3)

CIRCUIT NO.	PART NO.	DESCRIPTION
	Terminal	
P503	25045255	YKB21-5009

NOTE: THE COMPONENTS IDENTIFIED BY MARK Δ ARE CRITICAL FOR RISK OF FIRE AND ELECTRIC SHOCK. REPLACE ONLY WITH PART NUMBER SPECIFIED.

SCHEMATIC DIAGRAM

MODEL TX-V94ORDS

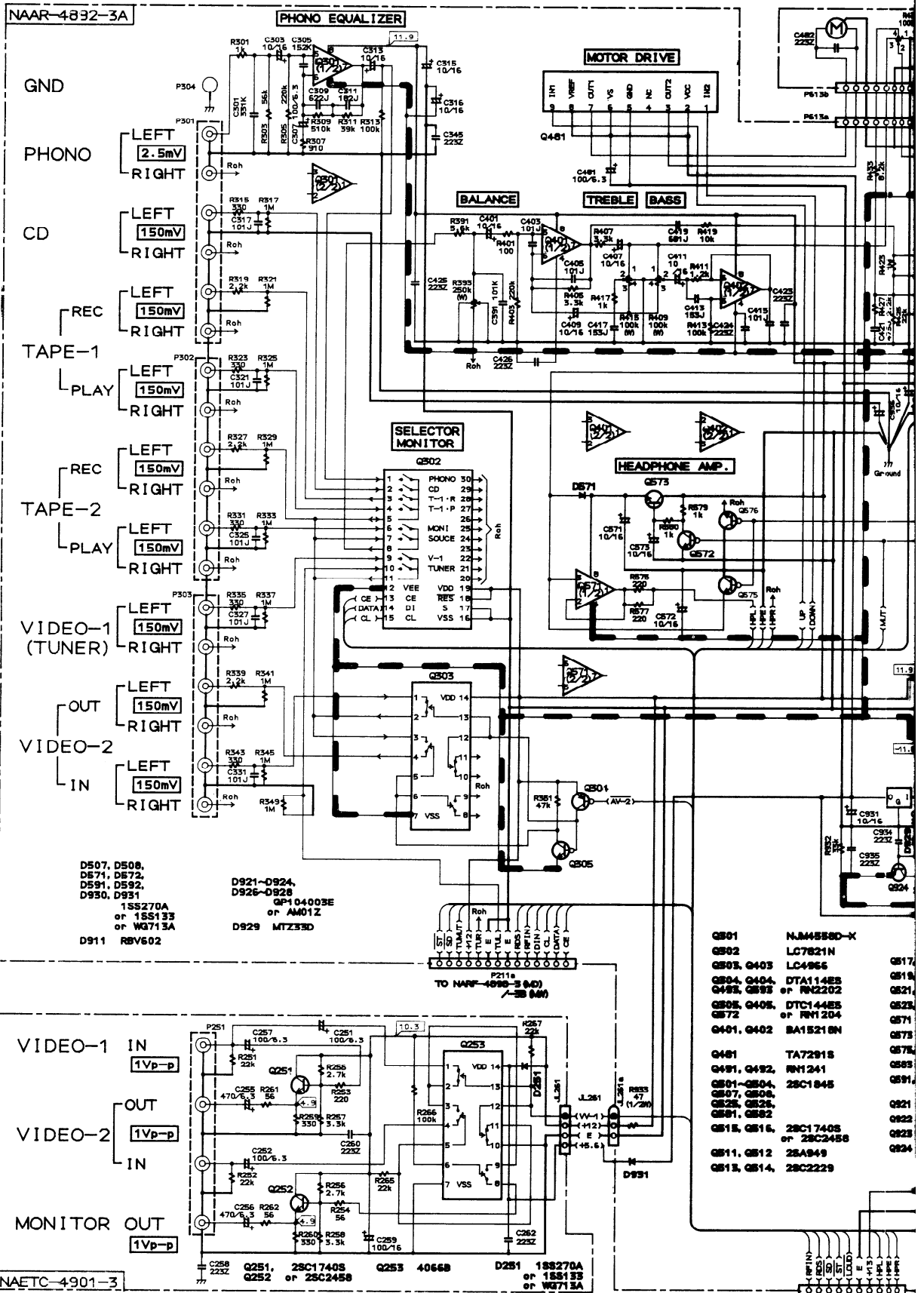

1

2

3

4

5

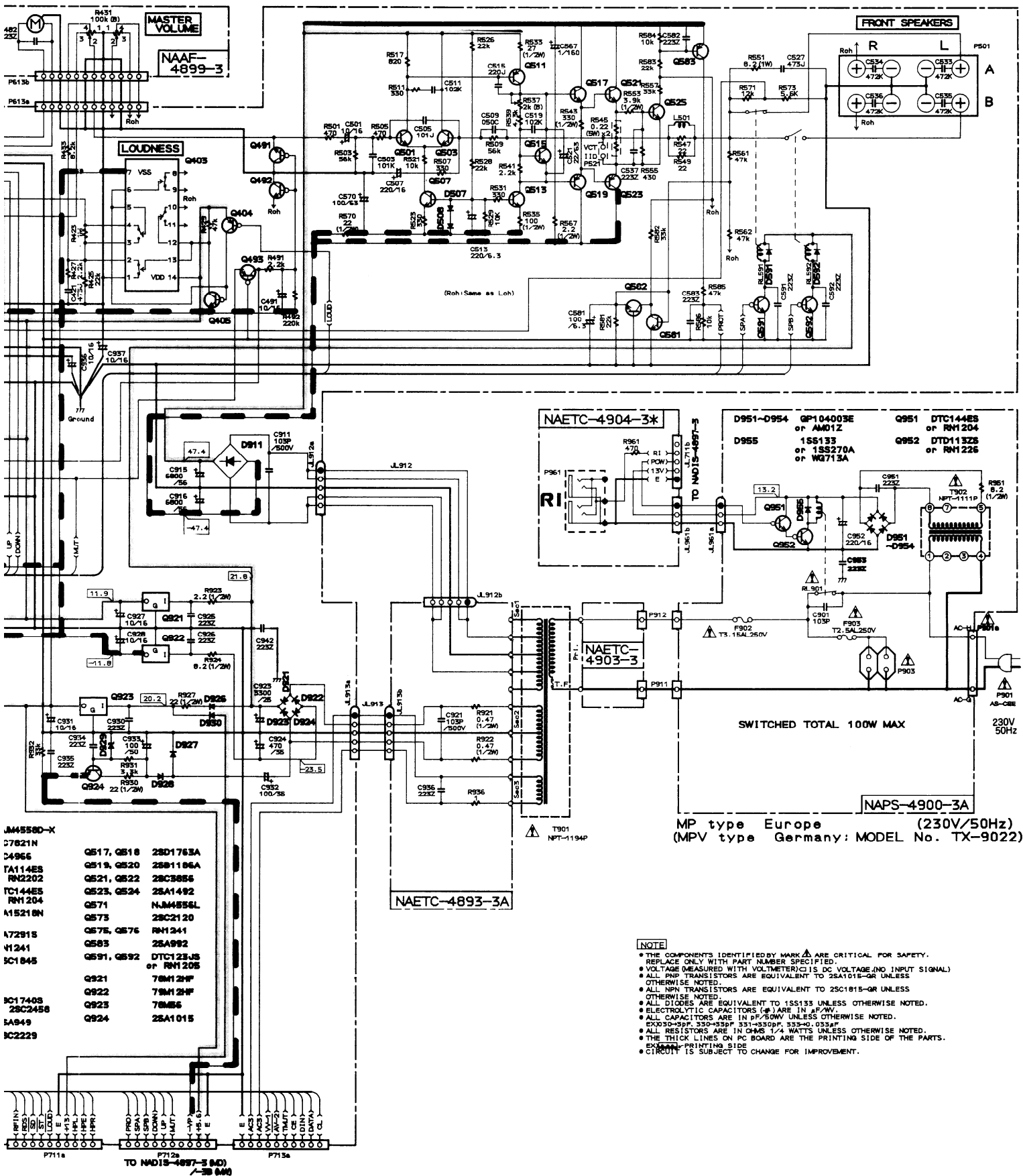

JM4558D-X

Q7621N	Q517, Q518	2SD1763A
Q4966	Q519, Q520	2SB1106A
TA114ES	Q521, Q522	28C3856
RM2202	Q523, Q524	2SA1492
TC144ES	Q571	NJM4556L
RM1204	Q573	28C2120
M15218N	Q575, Q576	RM1241
A72915	Q583	2SA992
V1241	Q591, Q592	DTC123JS or RM1205
SC1845	Q921	78M12HF
	Q922	79M12HF
SC1740S	Q923	78M05
28C2458	Q924	2SA1015
5A949		
SC2229		

NAPS-4900-3A
MP type Europe (230V/50Hz)
MPV type Germany: MODEL No. TX-9022

- NOTE**
- THE COMPONENTS IDENTIFIED BY MARK Δ ARE CRITICAL FOR SAFETY. REPLACE ONLY WITH PART NUMBER SPECIFIED.
 - VOLTAGE (MEASURED WITH VOLTMETER) IS DC VOLTAGE (NO INPUT SIGNAL)
 - ALL PNP TRANSISTORS ARE EQUIVALENT TO 2SA1015-GR UNLESS OTHERWISE NOTED.
 - ALL NPN TRANSISTORS ARE EQUIVALENT TO 2SC1815-GR UNLESS OTHERWISE NOTED.
 - ALL DIODES ARE EQUIVALENT TO 1SS133 UNLESS OTHERWISE NOTED.
 - ELECTROLYTIC CAPACITORS (E) ARE IN μ F/V.
 - ALL CAPACITORS ARE IN pF/50WV UNLESS OTHERWISE NOTED.
 - D \times 50-50pF, 50-50pF, 531-530pF, 535-0, 033pF
 - ALL RESISTORS ARE IN OHMS 1/4 WATTS UNLESS OTHERWISE NOTED.
 - THE THICK LINES ON PC BOARD ARE THE PRINTING SIDE OF THE PARTS.
 - EXPLANATION: PRINTING SIDE
 - CIRCUIT IS SUBJECT TO CHANGE FOR IMPROVEMENT.

A

B

C

D

SCHEMATIC DIAGRAM MODEL TX-V940RDS

1

2

3

4

5

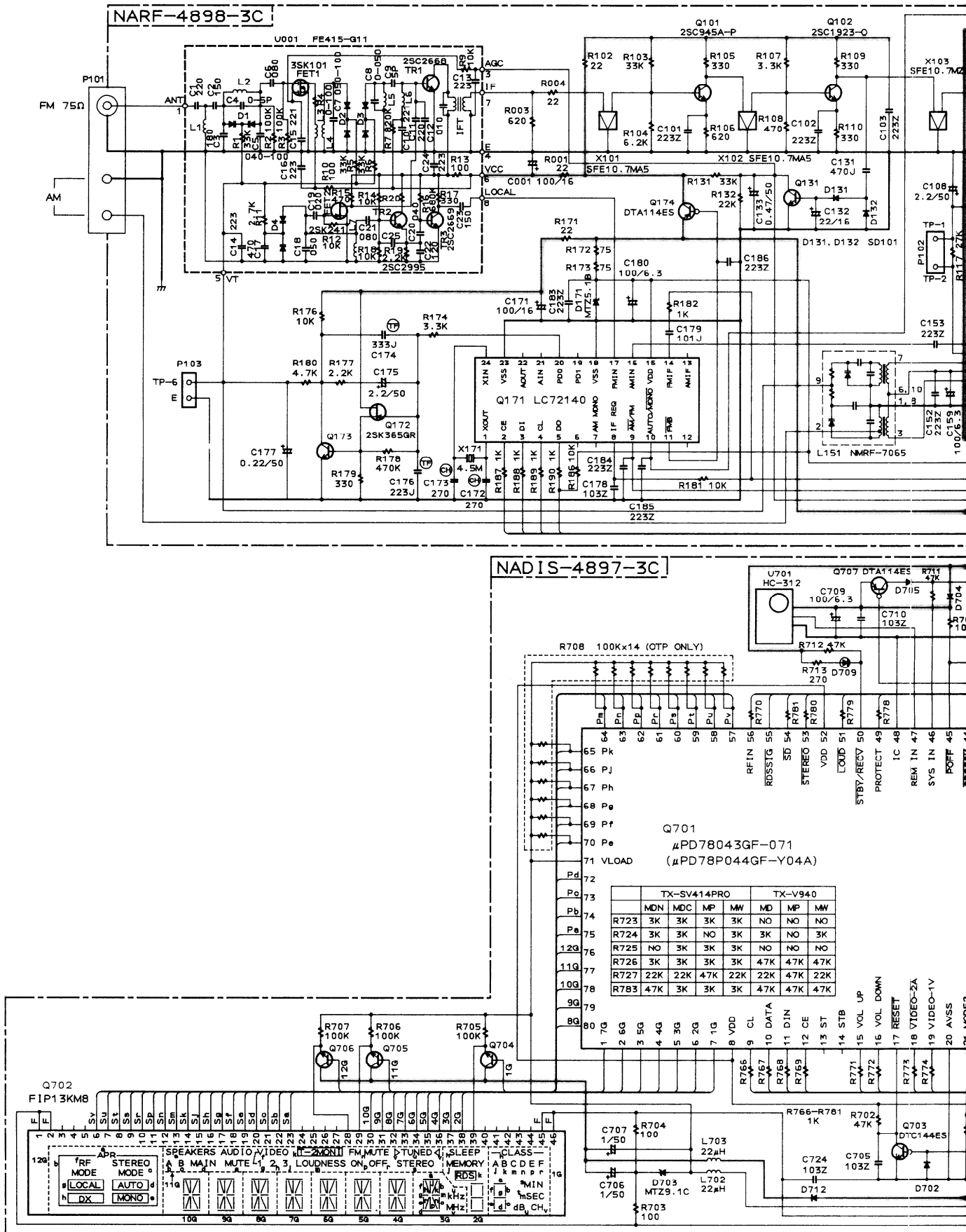

PRINTED CIRCUIT BOARD-PARTS LIST

MODEL TX-SV414PRO

MAIN CIRCUIT PC BOARD (NAAR-4892-1/1A)

CIRCUIT NO.	PART NO.	DESCRIPTION	CIRCUIT NO.	PART NO.	DESCRIPTION
	ICs			Transistors	
Q301	222502	NJM4558D-X	Q581,Q582	2211732 or 2211733	2SC1845-F or 2SC1845-E
Q302	22240280	LC7821N	Q583	2211792 or 2211793	2SA992-F or 2SA992-E
Q303,Q403	22240025	LC4966	Q591-Q593	2213640 or 2214660	DTC123JS or RN1205
Q401,Q402	22240247	BA15218N	Q924	2211455	2SA1015-GR
Q481	22240239	TA7291S		Diodes	
Q571	22240752	NJM4556L	D505,D506	223222,	WG713A,
Q921	22278012SNEC	78M12HF	D571,D572	223205 or	1SS270A or
Q922	22279012S	79M12HF	D591,D592	223163	1SS133
Q923	222780565JRC	78M56	D911	22380038	RBV602
	Transistors		D925	22380048	RBA402
Q304,Q404	2213510 or	DTA114ES or	D926-D928	22380035 or 22380046	GP104003E or AM01Z
Q493	2214350	RN2202	D929	224453304	MTZ33D
Q305,Q405	221282 or	DTC144ES or	D930,D931	223222,	WG713A,
Q572	2213560	RN1204		223205 or	1SS270A or
Q491,Q492	2213631 or	RN1241-A or		223163	1SS133
Q575,Q576	2213632	RN1241-B		Coils	
Q501-Q504	2211732 or	* 2SC1845-F or	L501,L502	231176S	S-1.3C
Q507,Q508	2211733	* 2SC1845-E		Capacitors	
Q505,Q506	2213354 or 2212125	2SA933S-R or 2SA1048-GR	C303,C304	354741009	10 μ F,16V,Elect.
Q509,Q510	2213284 or	2SC1740S-R or	C307,C308	354721019	100 μ F,6.3V,Elect.
Q515,Q516	2212115	2SC2458-GR	C309,C310	374726224	6200pF \pm 5%,50V,Plastic
Q511,Q512	2211353 or 2211354	2SA949-O or 2SA949-Y	C311,C312	374721824	1800pF \pm 5%,50V,Plastic
Q513,Q514	2211633 or 2211634	2SC2229-O or 2SC2229-Y	C313-C316	354741009	10 μ F,16V,Elect.
Q517,Q518	2201944, 2201945 or 2201946	* 2SD1763-D, * 2SD1763-E or * 2SD1763-F	C391,C392	374721015	100pF \pm 10%,50V,Plastic
Q519,Q520	2201934, 2201935 or 2201936	* 2SB1186-D, * 2SB1186-E or * 2SB1186-F	C401,C402	354741009	10 μ F,16V,Elect.
Q521,Q522	2202523, 2202524, 2202526, 2202292 or 2202293	* 2SC4468-O, * 2SC4468-Y, * 2SC4468-P, * 2SC3182N-R or * 2SC3182N-O	C407-C412	354741009	10 μ F,16V,Elect.
Q523,Q524	2202513, 2202514, 2202516, 2202282 or 2202283	* 2SA1695-O, * 2SA1695-Y, * 2SA1695-P, * 2SA1265N-R or * 2SA1265N-O	C413,C414	374721534	0.015 μ F \pm 5%,50V,Plastic
Q525,Q526	2211732 or 2211733	2SC1845-F or 2SC1845-E	C417,C418	374721534	0.015 μ F \pm 5%,50V,Plastic
Q573	2211163 or 2211164	2SC2120-O or 2SC2120-Y	C421,C422	374724734	0.047 μ F \pm 5%,50V,Plastic
Q575,Q576	2213631 or 2213632	RN1241-A or RN1241-B	C481	354721019	100 μ F,6.3V,Elect.
			C491	354741009	10 μ F,16V,Elect.
			C501,C502	354741009	10 μ F,16V,Elect.
			C503,C504	374721015	100pF \pm 10%,50V,Plastic
			C507,C508	354742219	220 μ F,16V,Elect.
			C513,C514	354722219	220 μ F,6.3V,Elect.
			C521,C522	354772209	22 μ F,63V,Elect.
			C527,C528	374724734	0.047 μ F \pm 5%,50V,Plastic
			C567,C568	354700109	1 μ F,160V,Elect.
			C570	354771019	100 μ F,63V,Elect.
			C571-C573	354741009	10 μ F,16V,Elect.
			C581	354721019	100 μ F,6.3V,Elect.
			C915,C916	3504263 or 3504268	* 8200 μ F,56V or * 8200 μ F,56V,Elect.
			C923	3504213	4700 μ F,35V,Elect.
			C924	354763329	3300 μ F,35V,Elect.

CAUTION: Replacement for transistor of mark *, if necessary, must be made from the same beta group (H β) as the original type.

SCHEMATIC DIAGRAM
MODEL TX-SV414PRO

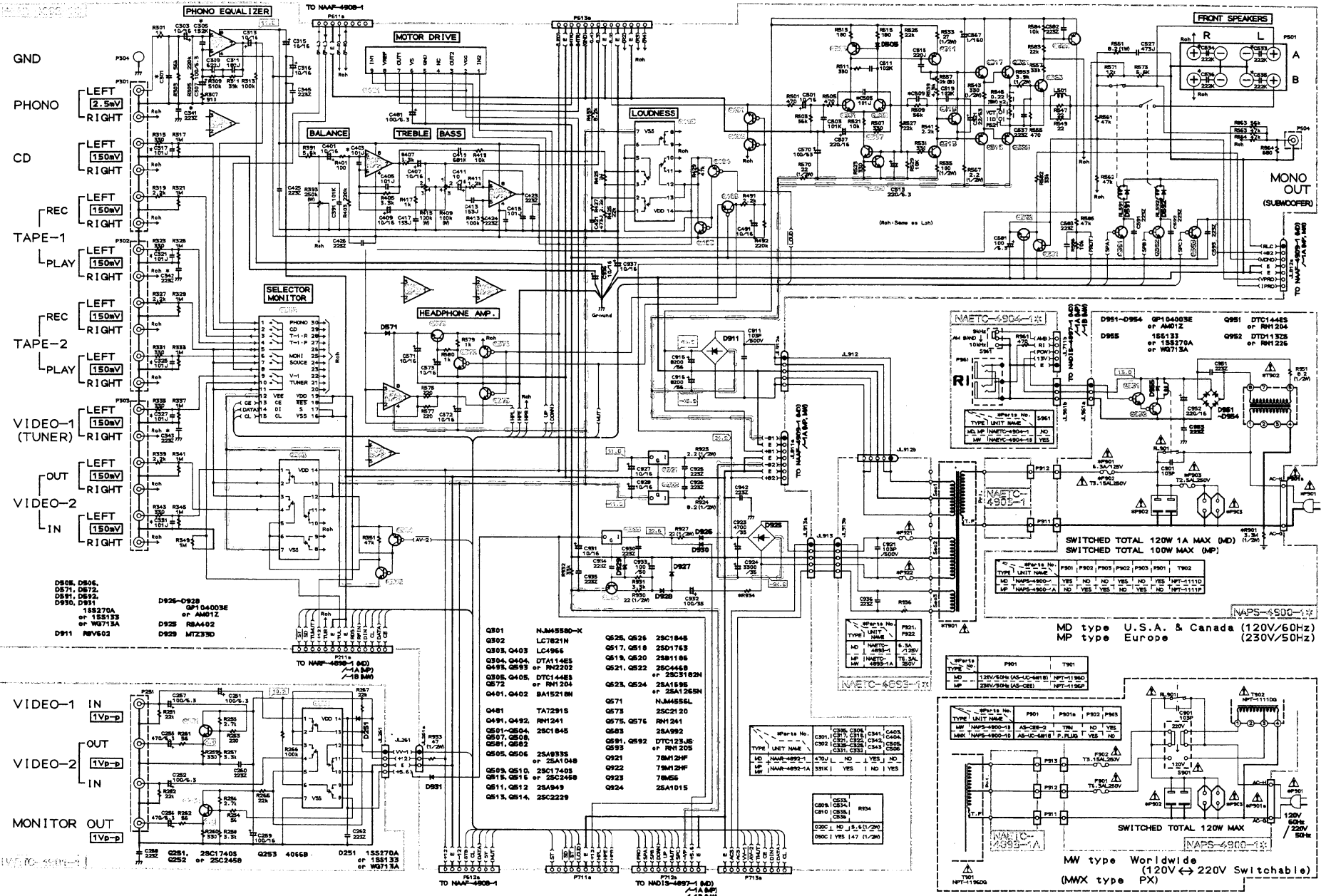

1

2

3

4

5

Q301	N.M45580-X	Q525, Q526	2SC1848
Q302	LC7821H	Q517, Q518	2SC1763
Q303, Q403	LC9466	Q519, Q520	2SA1186
Q304, Q404, Q7A114E5		Q521, Q522	2SC4468
Q405, Q505	PN2202	Q523, Q524	2SC3182N
Q305, Q405, DTC144E5	of RM1204	Q525, Q526	2SA1896
Q401, Q402	8A15218N	Q527	of 2SA1255N
Q481	TA7291S	Q571	N.M4555L
Q491, Q492, RM1241		Q573	2SC2120
Q501-Q504, 2SC1848		Q575, Q576	RM1241
Q507, Q508, Q581, Q582		Q583	2SA992
Q505, Q506, 2SA933S		Q581, Q592	DTC123J5
Q509, Q510, 2SC1740S		Q593	of RM1205
Q515, Q516	of 2SC2458	Q921	78M120F
Q511, Q512	2SA949	Q922	78M120F
Q513, Q514, 2SC2229		Q923	78M55
		Q924	2SA1015

MD type U.S.A. & Canada (120V/60Hz)
MP type Europe (230V/50Hz)

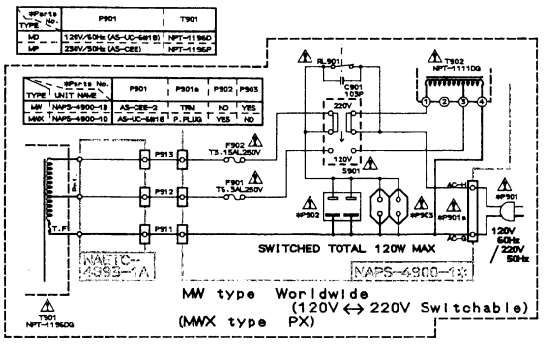

SCHEMATIC DIAGRAM MODEL TX-SV414PRO

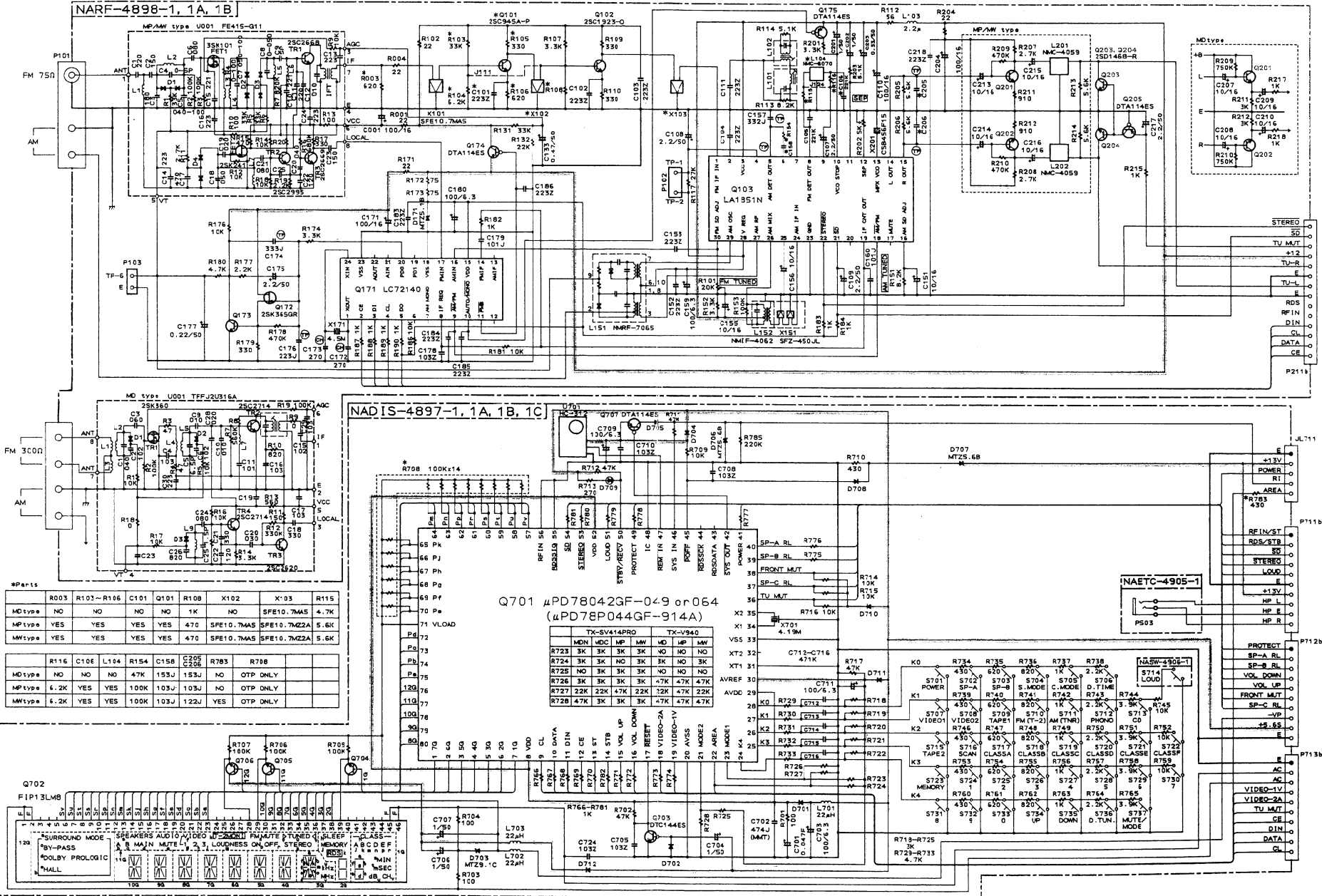

#Parts

	R003	R103-R106	C101	Q101	R108	X102	X'03	R115
MDtype	NO	NO	NO	NO	1K	NO	SFE10.7MAS	4.7K
MPtype	YES	YES	YES	470	SFE10.7MAS	SFE10.7M2ZA	5.6K	
MMtype	YES	YES	YES	470	SFE10.7MAS	SFE10.7M2ZA	5.6K	

	R116	C106	L104	R154	C158	C205	R703	R708
MDtype	NO	NO	NO	47K	153J	NO	OTP ONLY	
MPtype	6.2K	YES	YES	100K	103J	103J	NO	OTP ONLY
MMtype	6.2K	YES	YES	100K	103J	122J	YES	OTP ONLY

Q701 μ PD7804-2GF-049 or 064
(μ PD78P044GF-914A)

	TX-SV414PRO	TX-V940
R723	3K 3K	3K 3K
R724	3K 3K	NO 3K
R725	NO 3K	NO 3K
R726	3K 3K	3K 47K
R727	22K 22K	47K 22K
R728	47K 3K	3K 47K

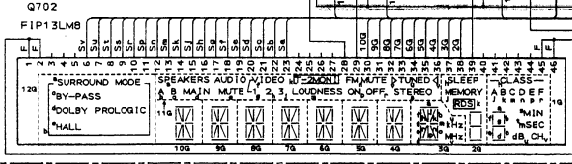

TUNER CIRCUIT PC BOARD (NARF-4898-1/1A/1B)

CIRCUIT NO.	PART NO.	DESCRIPTION
	Front end	
TU001	240095Y	TFFJ2U316A <D>
	240089	FE415-G11 <P/W>
	ICs	
Q103	22240749Y	LA1851N
Q171	22240750Y	LC72140
	Transistors	
Q101	2210746	2SC945A-P <P/W>
Q102	2211723	2SC1923-O
Q172	2212445	2SK365-GR
Q173	2213284 or	2SC1740S-R or
Q201,Q202	2212115	2SC2458-GR
Q174,Q175	2213510 or	DTA114ES or
Q205	2214350	RN2202
Q203,Q204	2212794	2SD1468-R
	Diode	
D171	224450512	MTZ5.1B
	Resonators	
X171	3010228Y	XTL-4.5M,Crystal
X201	3010227Y	CSB456F15,Ceramic
	Coils and transformers	
L101	233457Y	NFIF-4081
L102	233458Y	NFIF-4082
L103	233454M022	NCH-1452 022M
L104	233383	NMC-6070 <P/W>
L201,L202	233355A	NMC-4059 <P/W>
L151	232163	NMRF-7065
L152	232139	NMIF-4062
	Ceramic filters	
X101	3010071	SFE10.7MA5
X102	3010071	SFE10.7MA5 <P/W>
X103	3010071	SFE10.7MA5 <D>
	3010130	SFE10.7MZZA <P/W>
X151	3010123	SFZ-450JL
	Capacitors	
C001	354741019	100 μ F,16V,Elect.
C107-C109	354780229	2.2 μ F,50V,Elect.
C110	354741019	100 μ F,16V,Elect.
C133	354784799	0.47 μ F,50V,Elect.
C151	354741009	10 μ F,16V,Elect.
C155,C156	354741009	10 μ F,16V,Elect.
C157	374723324	3300pF \pm 5%,50V,Plastic
C158	374721534	0.015 μ F \pm 5%,50V,Plastic <D>
	374721034	0.01 μ F \pm 5%,50V,Plastic <P/W>
C159,C180	354721019	100 μ F,6.3V,Elect.
C174	374723334	0.033 μ F \pm 5%,50V,Plastic
C175	354780229	2.2 μ F,50V,Elect.
C176	374722234	0.022 μ F \pm 5%,50V,Plastic
C177	354782299	0.22 μ F,50V,Elect.

CIRCUIT NO.	PART NO.	DESCRIPTION
	Capacitors	
C201,C202	354780109	1 μ F,50V,Elect.
C203	354783399	0.33 μ F,50V,Elect.
C204	354741019	100 μ F,16V,Elect.
C205,C206	374721534	0.015 μ F \pm 5%,50V,Plastic <D>
	374721034	0.01 μ F \pm 5%,50V,Plastic <P>
	374721234	0.012 μ F \pm 5%,50V,Plastic <W>
C207-C210	354741009	10 μ F,16V,Elect. <D>
C213-C216	354741009	10 μ F,16V,Elect. <P/W>
C217	354780229	2.2 μ F,50V,Elect.
	Resistors	
R101	5210263	N06HR 20KBC,Trim
R202	5210259	N06HR2KBC,Trim
	Terminal	
P101	25060160	NTM-4PDML086 <D>
	25060117	NTM-2PDML051 <P/W>
	Socket	
P211b	25050986	NSCT-14P773

POWER SUPPLY CIRCUIT PC BOARD (NAPS-4900-1/1A/1B/1D)

CIRCUIT NO.	PART NO.	DESCRIPTION
	Transistors	
Q951	221282 or	DTC144ES or
	2213560	RN1204
Q952	2213650 or	DTD113ZS or
	2214680	RN1226
	Diodes	
D951-D954	22380035 or	GP104003E or
	22380046	AM01Z
D955	223222,	WG713A,
	223205 or	ISS270A or
	223163	ISS133
	Capacitors	
C901	3500065A	Δ DE7150FZ103PAC400V/125V
C952	354742219	220 μ F,16V,Elect.
	Resistors	
R901	431523355	Δ 3.3M Ω ,1/2W,Solid <D>
R951	453530824	8.2 ohm,1/2W,Metal
	Power transformer	
T902	2300670	Δ NPT-1111D <D>
	2300671	Δ NPT-1111P <P>
	2300672	Δ NPT-1111DG <W>
	Relay	
RL901	25065483	Δ NRL-1P5A-DC-12-084
	Fuses	
F901	252166Y	Δ 6.3A-UL/T-237 <D/W>
F902	252076	Δ 3.15A-SE-EAK <P/W>
F903	252075	Δ 2.5A-SE-EAK <P>

NOTE: THE COMPONENTS IDENTIFIED BY MARK Δ ARE CRITICAL FOR RISK OF FIRE AND ELECTRIC SHOCK. REPLACE ONLY WITH PART NUMBER SPECIFIED.

SCHEMATIC DIAGRAM
MODEL TX-V940RDS

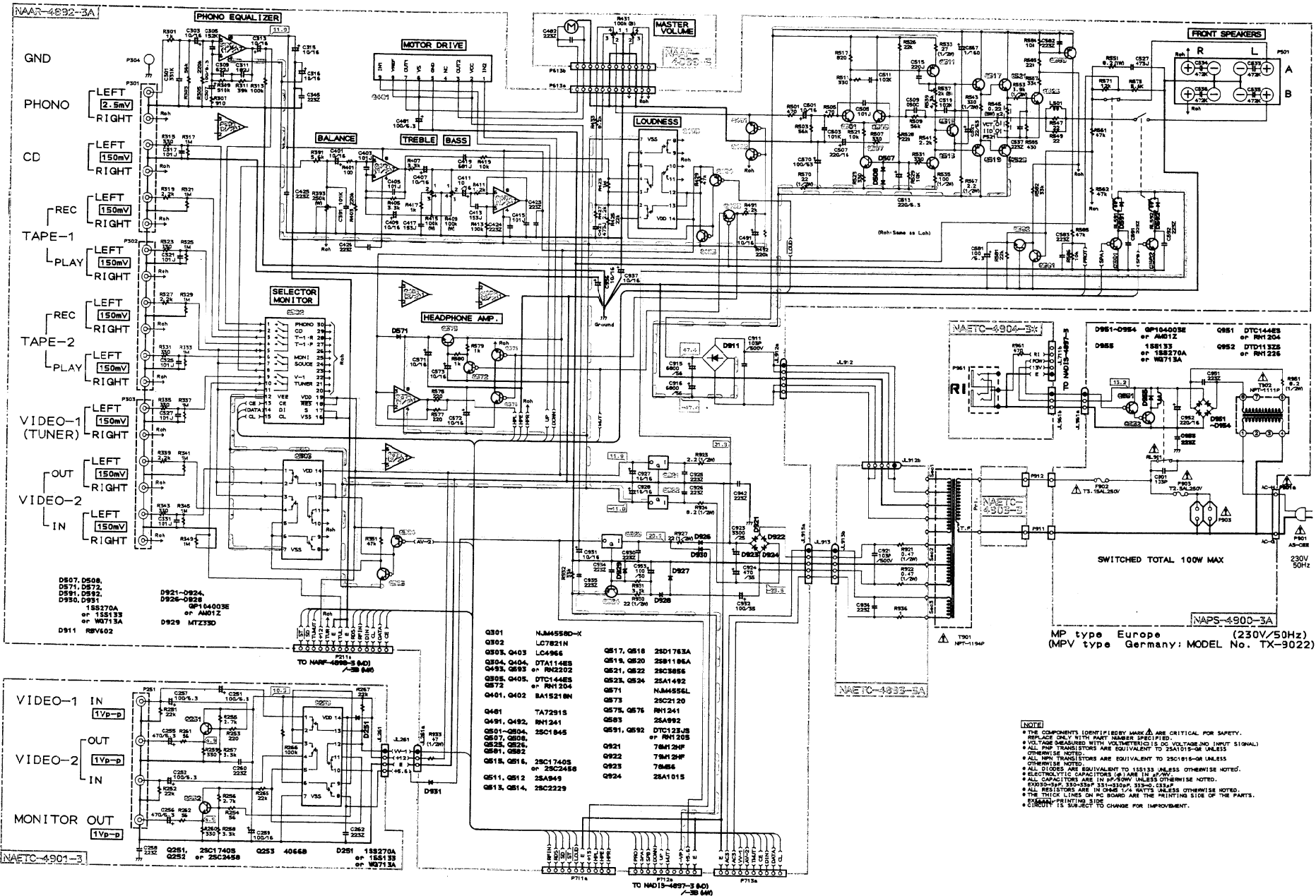

CIRCUIT NO. PART NO. DESCRIPTION			SURROUND CIRCUIT PC BOARD (NAAF-4908-1)		
Fuseholders			CIRCUIT NO. PART NO. DESCRIPTION		
F901a	25050065	△ YSH403T <D/W>	Q601	22240247 or	BA15218N or
F902a	25050065	△ YSH403T <P/W>	Q673,Q674	22240293	NJM4558L-D
F903a	25050065	△ YSH403T <P>	Q602	22240683 or	NJM2177L or
Plug				22240692	M69032P
P901a	25055675	NPLG-2P631 <D>	Q606	22240398 or	TC9162N or
Socket				22240751	NJU7311L
P902	25051126	△ NSCT-4P913,AC outlet <D/PX>	Q651	22240686 or	M65830P or
	25051125	△ NSCT-4P912,AC outlet <P/W>		22240687	NJU9701D
Switch			Q671	22240266	TC9213P
S901	25065437	△ NSS-22157P,Voltage selector <W>	Transistors		
VIDEO CIRCUIT PC BOARD (NAETC-4901-1)			Q603,Q604	2213631 or	RN1241-A or
CIRCUIT NO. PART NO. DESCRIPTION			Q675,Q676	2213632	RN1241-B
IC			Diodes		
Q253	222840661	4066B	D651	224450562	MTZ5.6B
Transistors			D652,D653	223222,	WG713A,
Q251,Q252	2213284 or	2SC1740S-R or		223205 or	1SS270A or
	2212115	2SC2458-GR		223163	1SS133
Diode			Resonator		
D251	223222,	WG713A,	X651	3010217	CST2.04MG040,Ceramic
	223205 or	1SS270A or	Capacitors		
	223163	1SS133	C601,C602	354780229	2.2 μ F,50V,Elect.
Capacitors			C605,C606	354741009	10 μ F,16V,Elect.
C251,C252	354721019	100 μ F,6.3V,Elect.	C607-C610	354781099	0.1 μ F,50V,Elect.
C255,C256	354724719	470 μ F,6.3V,Elect.	C613,C614	374724734	0.047 μ F ± 5%,50V,Plastic
C257	354721019	100 μ F,6.3V,Elect.	C615,C616	374722234	0.022 μ F ± 5%,50V,Plastic
C259	354741019	100 μ F,16V,Elect.	C617-C620	354781099	0.1 μ F,50V,Elect.
Terminal			C621,C622	354780479	4.7 μ F,50V,Elect.
P251	25045339	NPJ-4PDYE190	C623-C627	354782299	0.22 μ F,50V,Elect.
RI TERMINAL PC BOARD(NAETC-4904-1/1B)			C628	354741009	10 μ F,16V,Elect.
CIRCUIT NO. PART NO. DESCRIPTION			C629	354786899	0.68 μ F,50V,Elect.
Terminal			C630	374724734	0.047 μ F ± 5%,50V,Plastic
P961	25045330	NPJ-2PDBL184	C631,C660	374725625	5600pF ± 5%,50V,Plastic
Switch			C632	354780229	2.2 μ F,50V,Elect.
S961	25065286	NSS-22112 <W>	C634	354722219	220 μ F,6.3V,Elect.
HEADPHONE TERMINAL PC BOARD(NASW-4905-1)			C635	354741019	100 μ F,16V,Elect.
CIRCUIT NO. PART NO. DESCRIPTION			C636-C641	354741009	10 μ F,16V,Elect.
Terminal			C642	374724724	4700pF ± 5%,50V,Plastic
P503	25045255	YKB21-5009	C643	354741009	10 μ F,16V,Elect.
LOUDNESS SWITCH PC BOARD(NASW-4906-1)			C644	392841007	10 μ F,16V,Elect.
CIRCUIT NO. PART NO. DESCRIPTION			C651	354782299	0.22 μ F,50V,Elect.
Switch			C653	374723924	3900pF ± 5%,50V,Plastic
S714	25035652	NPS-111-S604	C655	374726834	0.068 μ F ± 5%,50V,Plastic
			C656	354744709	47 μ F,16V,Elect.
			C657,C658	354781099	0.1 μ F,50V,Elect.
			C659	374726834	0.068 μ F ± 5%,50V,Plastic
			C661	374724724	4700pF ± 5%,50V,Plastic
			C663,C665	354721019	100 μ F,6.3V,Elect.
			C666	375524744	0.47 μ F ± 5%,50V,Plastic

CIRCUIT NO.	PART NO.	DESCRIPTION	CIRCUIT NO.	PART NO.	DESCRIPTION
	Capacitors			Transistors	
C671,C672	354780229	2.2 μ F,50V,Elect.	Q823	2202243,	* 2SA1694-O,
C675,C676	354741009	10 μ F,16V,Elect.		2202244,	* 2SA1694-Y,
C677,C678	354780229	2.2 μ F,50V,Elect.		2202246,	* 2SA1694-P,
C679-C682	354741009	10 μ F,16V,Elect.		2202492 or	* 2SA1264N-R or
C684,C685	354741009	10 μ F,16V,Elect.		2202493	* 2SA1264N-O
	Resistor		Q824	2202363,	* 2SA1693-O,
R431	5104332Y	N16RQL100KBT25F,Main volume		2202364,	* 2SA1693-Y,
	Plug			2202365,	* 2SA1693-P,
P622a	25055405	NPLG-3P387		2202342 or	* 2SA1263N-R or
	Sockets			2202343	* 2SA1263N-O
P611b	25051127	NSCT-8P914		Diodes	
P612b	25050983	NSCT-8P770	D805,D806	223222,	WG713A,
P613b	25050986	NSCT-14P773	D811	223205 or	1SS270A or
P621a	2000802ULY	NSAS-6P758		223163	1SS133
				Coils	
CENTER AND REAR AMPLIFIER PC BOARD (NAAF-4909-1/1A)			L801,L802	231176S	S-1.3C
CIRCUIT NO.	PART NO.	DESCRIPTION		Capacitors	
	Transistors		C801,C802	354741009	10 μ F,16V,Elect.
Q801-Q804	2211732 or	* 2SC1845-F or	C807	354742219	220 μ F,16V,Elect.
Q807,Q808	2211733	* 2SC1845-E	C808	354744709	47 μ F,16V,Elect.
Q805,Q806	2213354 or	2SA933S-R or	C821,C822	374724734	0.047 μ F \pm 5%,50V,Plastic
	2212125	2SA1048-GR	C827,C828	374724734	0.047 μ F \pm 5%,50V,Plastic
Q809,Q810	2213284 or	2SC1740S-R or	C865,C867	354700109	1 μ F,160V,Elect.
Q815,Q816	2212115	2SC2458-GR	C866	354784709	47 μ F,50V,Elect.
Q811,Q812	2211353 or	2SA949-O or	C868,C870	374724734	0.047 μ F \pm 5%,50V,Plastic
	2211354	2SA949-Y	C869	354700109	1 μ F,160V,Elect.
Q813	2211633 or	2SC2229-O or		Resistors	
	2211634	2SC2229-Y	R833,R834	443522704	27 ohm,1/2W,Metal oxide
Q814	2211732 or	2SC1845-F or	R835,R836	442521014	100 ohm,1/2W,Metal oxide
Q825,Q826	2211733	2SC1845-E	R837	5215044	N08HR 2KBC,Trim
Q817	2212653 or	2SC3421-O or	R843,R844	443523314	330 ohm,1/2W,Metal oxide
	2212654	2SC3421-Y	R845	4000132Y	0.22 ohm \times 2.5W + 5W,Metal plate
Q818	2211653 or	2SC2235-O or	R846	4000131Y	0.22 ohm \times 2.2W + 2W,Metal plate
	2211654	2SC2235-Y	R851,R852	453530824	8.2 ohm,1/2W,Metal
Q819	2212643 or	2SA1538-O or	R853,R854	443523924	3.9 kohm,1/2W,Metal oxide
	2212644	2SA1538-Y	R865,R866	453530224	2.2 ohm,1/2W,Metal
Q820	2211643 or	2SA965-O or	R867-R870	443522204	22 ohm,1/2W,Metal oxide
	2211644	2SA965-Y		Relay	
Q821	2202253,	* 2SC4467-O,	RL801	25065485	NRL-2P2A-DC24-086
	2202254,	* 2SC4467-Y,		Plugs	
	2202256,	* 2SC4467-P,	P621b	25055234	NPLG-3P218
	2202502 or	* 2SC3181N-R or		Terminal	
	2202503	* 2SC3181N-O	P801	25060191Y	NTM-6PDML113
Q822	2202373,	* 2SC4466-O,			
	2202374,	* 2SC4466-Y,			
	2202375,	* 2SC4466-P,			
	2202352 or	* 2SC3180N-R or			
	2202353	* 2SC3180N-O			

CAUTION: Replacement for transistor of mark * if necessary, must be made from the same beta group (H β) as the original type.

NOTE: THE COMPONENTS IDENTIFIED BY MARK Δ ARE CRITICAL FOR RISK OF FIRE AND ELECTRIC SHOCK. REPLACE ONLY WITH PART NUMBER SPECIFIED.

PACKING VIEW

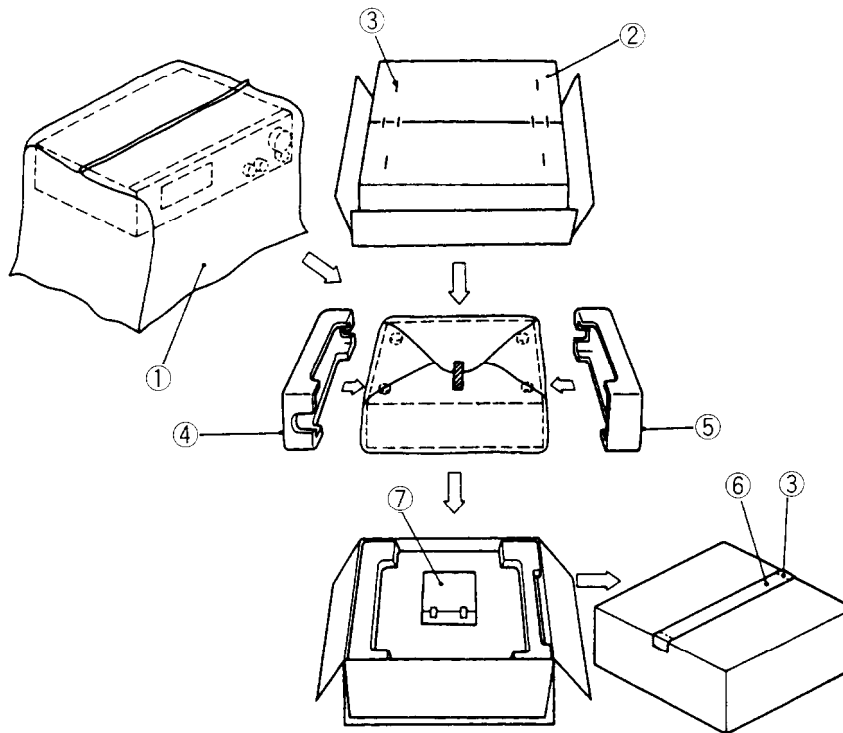

TX-V940/TX-V940RDS PARTS LIST

REF.NO.	PART NO.	DESCRIPTION
1	29100034-1Y	Styrene bag for unit
2	29052692Y	Carton box <D/W>
	29052705Y	Carton box <P>
3	282301	Ten staples
4	29091652BY	Pad R
5	29091651BY	Pad L
6	29110071	PP tape
7	Accessory bag ass'y	
	232140	NMA-3057,AM loop antenna
	2010200	Cord RI
	3010054	UM-3,Two batteries
	25055018	CV-K-1,Conversion plug <W>
	25065462	YAE21-0237, Antenna adaptor <W>
	24140261AY	RC-261S,Remote control transmitter
	29100097-1Y	Styrene bag for accessory
	292111Y	FM antenna <D>
	292112Y	FM antenna <P/W>
	29341901Y	Instruction manual
	29341904Y	Instruction manual <P>
	29341903Y	Instruction manual <C/W>
	29358002K	Service station list <N>
	29361678Y	Label UPC <N>
	29365019A	Warranty card <N>
	29360778	Label FLASH <N/C>

NOTE: <D>:120V model only
 <P>:230V model only <TX-V940RDS only>
 <W>:Worldwide model only
 <N>:USA model only
 <C>:Canadian model only

TX-SV414PRO PARTS LIST

REF.NO.	PART NO.	DESCRIPTION	NOTE: <D>:120V model only
1	29100034-1Y	Styrene bag for unit	<W>:Worldwide model only
2	29052696Y	Carton box	<N>:USA model only
	29052698Y	Carton box <PX>	<C>:Canadian model only
3	282320	Ten staples	
4	29091652BY	Pad R	
5	29091651BY	Pad L	
6	29110071	PP tape	
7	Accessory bag ass'y		
	232140	NMA-3057,AM loop antenna	
	2010200	Cord RI	
	3010054	UM-3,Two batteries	
	25055018	CV-K-1,Conversion plug <W>	
	25055251	CV-CP,Conversion plug <PX>	
	28330072	Two caps <PX>	
	25065462	YAE21-0237, Antenna adaptor <W>	
	24140262AY	RC-262S,Remote control transmitter	
	29100097-1Y	Styrene bag for accessory	
	292111Y	FM antenna <D>	
	292112Y	FM antenna <P/W>	
	29341901Y	Instruction manual	
	29341903Y	Instruction manual <C/W>	
	29341904Y	Instruction manual <P>	
	29380084	Instruction sheet <PX>	
	29358002J	Service station list <N/PX>	
	29361680Y	Label UPC <N/PX>	
	29365019A	Warranty card <N>	
	29365021	Warranty card <PX>	