

Service Manual

Portable CD Player

COMPACT
disc
DIGITAL AUDIO

MASH
multi-stage noise shaping

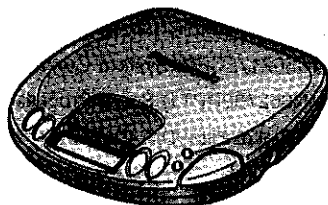

SL-S214

Traverse Deck: RAE0145Z Mechanism series

Colour

(A).....Blue Type [(EG) area only]

(S).....Silver Type

Areas

(E).....Great Britain.

(EG).....Europe and CIS.

Specifications

Audio (Anti-shock memory OFF)

No. of channels: 2 channels (left and right, stereo)
DA converter: 1 bit, MASH
Headphones output level: Max. 9 mW+9 mW/16 Ω (adjustable)
 stereo mini jack diameter 3.5

Pickup

Light source: Semiconductor laser
Wavelength: 780 nm

General

Operational temperature range: 0 – 40 degree
Rechargeable temperature range: 5 – 40 degree
Power supply: DC 4.5 V
Power consumption: Anti-shock memory OFF/ON
AC adaptor; 3.3 W / 3.5 W
Battery (DC 3V); 0.4 W / 0.4 W
When recharging; 4.2 W

Playing time:

(When used in hold mode, with S-XBS canceled at 25 degree temperature, on a flat, stable surface.)

Battery used: Anti-shock memory OFF/ON
Panasonic Alkaline dry cell batteries (LR6, 2pcs.);
 Approx. 20 h / 16 h

Optional Rechargeable batteries (P-3GAVE/2B);
 Approx. 8.5 h / 8 h

The play time may be less depending on the operating conditions.

Recharging time: Approx. 5 h

Dimensions (W x H x D): 128 x 25.8 x 144 mm

Mass: 257 g with batteries
 212 g without batteries

Notes: Specifications are subject to change without notice.
 Mass and dimensions are approximate.

⚠ WARNING

This service information is designed for experienced repair technicians only and is not designed for use by the general public. It does not contain warnings or cautions to advise non-technical individuals of potential dangers in attempting to service a product. Products powered by electricity should be serviced or repaired only by experienced professional technicians. Any attempt to service or repair the product or products dealt with in this service information by anyone else could result in serious injury or death.

Panasonic®

© 2000 Matsushita Electric Industrial Co., Ltd. All rights reserved. Unauthorized copying and distribution is a violation of law.

CONTENTS

	Page		Page
1 Location of Controls	2	7.2. Display of automatic adjustment results (Self-Check Function)	9
2 Accessories	2	8 Display of Self-Diagnostic Function	10
3 Precaution of Laser Diode	3	9 Type Illustration of ICs, Transistors and Diodes	10
4 Handling Precautions for Traverse Deck	3	10 Schematic Diagram Notes	10
4.1. Handling of traverse deck (optical pickup)	3	11 Schematic Diagram	11
4.2. Grounding for electrostatic breakdown prevention	4	12 Printed Circuit Board and Wiring Connection Diagram	16
5 Operation Checks and Component Replacement Procedures	4	13 Block Diagram	18
5.1. Checking for the main P.C.B.	4	14 Terminal Function of ICs	22
5.2. Replacement for the CD cover ass'y	6	14.1. IC11 (RS10003E2):DC-DC Converter	22
5.3. Replacement for the traverse motor	6	14.2. IC101 (AN8839NSBE1):Servo Amp	22
5.4. Replacement for the optical pickup	7	14.3. IC301 (SC502172CPB):System Control/LCD Drive	22
6 Checking the Operation Problems on the Traverse Deck (Optical Pickup)	8	14.4. IC501 (MN862782RPT1):Servo Processor/Digital Signal Processor/Digital Filter/D/A Converter	23
6.1. Check the operations described below on the traverse deck after replacing	8	15 Replacement Parts List	24
7 Automatic Adjustment Results Display Function (Self-Check Function)	9	16 Cabinet Parts Location	26
7.1. How to display automatic adjustment results	9	17 Traverse Unit Parts Location	27
		18 Packaging	28

1 Location of Controls

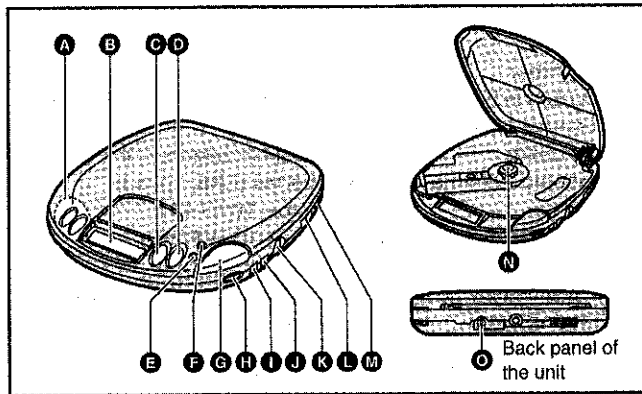

- A** Skip/search buttons (|<<<, >>>| <<<, >>>)
- B** Display
- C** Stop/operation off button (■, OPR OFF)
- D** Play/pause button (▶||)
- E** Repeat button (↺)
- F** Memory/recall button (MEMORY/RECALL)
- G** Open button (OPEN)
- H** Headphone volume control (VOLUME)
- I** Anti-shock button (A.SHOCK)
- J** S-XBS button (S-XBS)
- K** Headphone jack (⌀)
- L** Play mode selector (RESUME, RANDOM, NORMAL)
- M** Hold switch (HOLD)
- N** CD release button (PUSH)
- O** DC IN jack (⌀-⌀ DC IN 4.5 V)

2 Accessories

- AC adaptor for (EG) area only (RFEA419E-M).....1 pc.
- Stereo earphones (RFEV334P-KS).....1 pc.

NOTE:

- The tip of screw must not protrude above the floating rubber.
- To keep insulation, place the insulator sheet (paper etc.) between the P.C.B. and the head of screws.

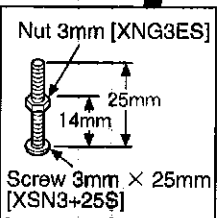
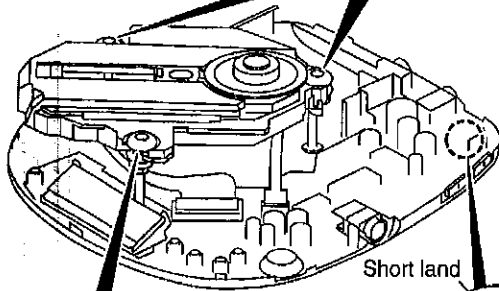
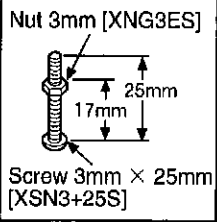

(Step 5)
Short-circuit the land by soldering.



(Step 6)
Sustain the traverse deck ass'y with the floating rubber inserted screws and nuts as shown above.

- Check the main P.C.B. (A side) as shown below.

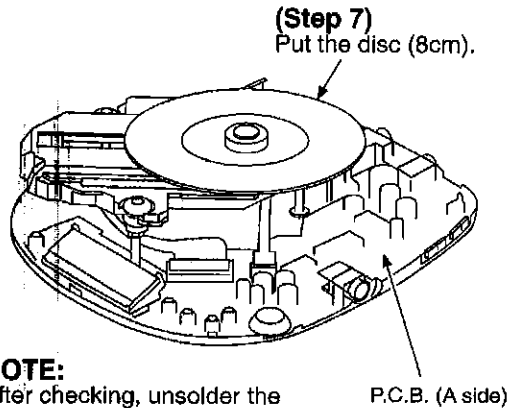

NOTE:

After checking, unsolder the short land to open circuit.

5.1.2. Checking for the main P.C.B. (B side)

- Follow the (Step 1) - (Step 5) of item 5.1.1.

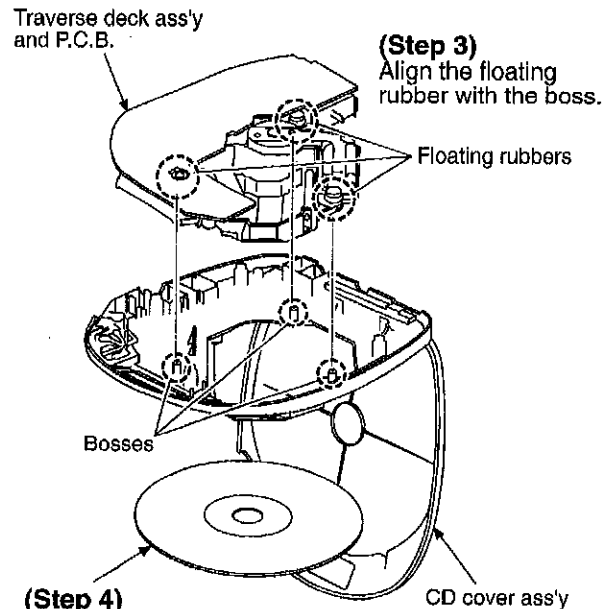
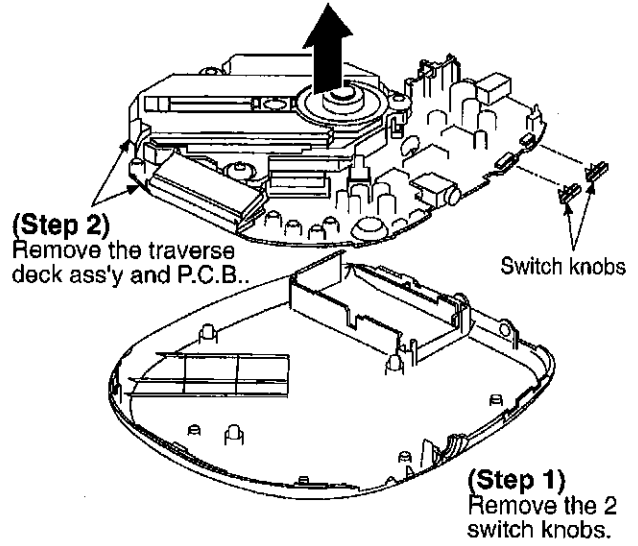

- Check the main P.C.B. (B side) as shown below.

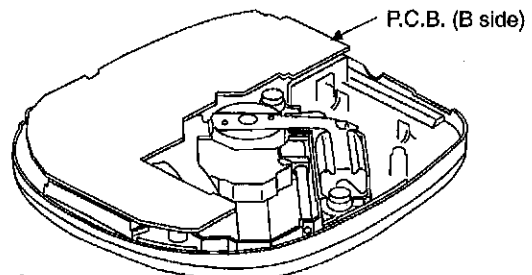

NOTE:

After checking, unsolder the short land to open circuit.

Notice for installation of switch knobs

- Make sure the bosses of switch are fit in the switch knobs.

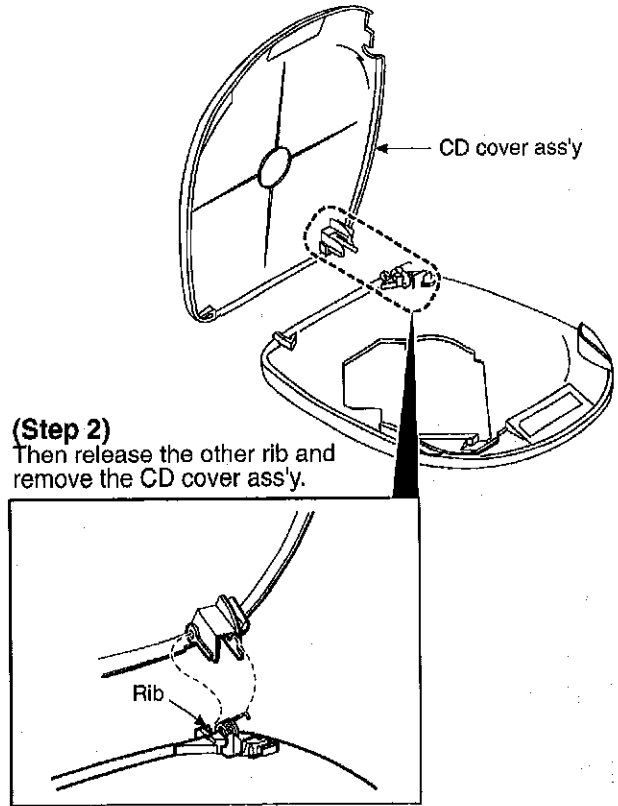
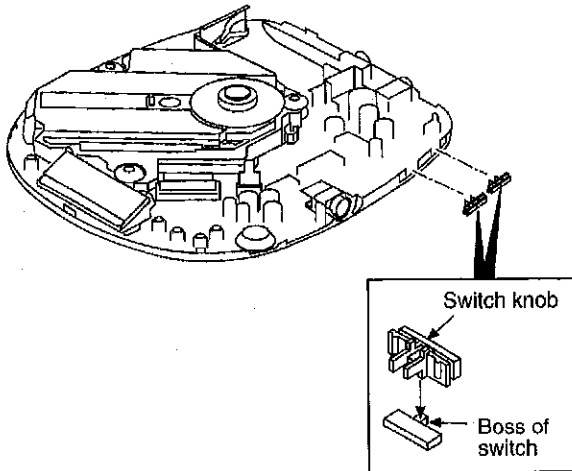

(Step 2)
Then release the other rib and remove the CD cover ass'y.

5.2. Replacement for the CD cover ass'y

- Follow the (Step 1) - (Step 4) of item 5.1.1.

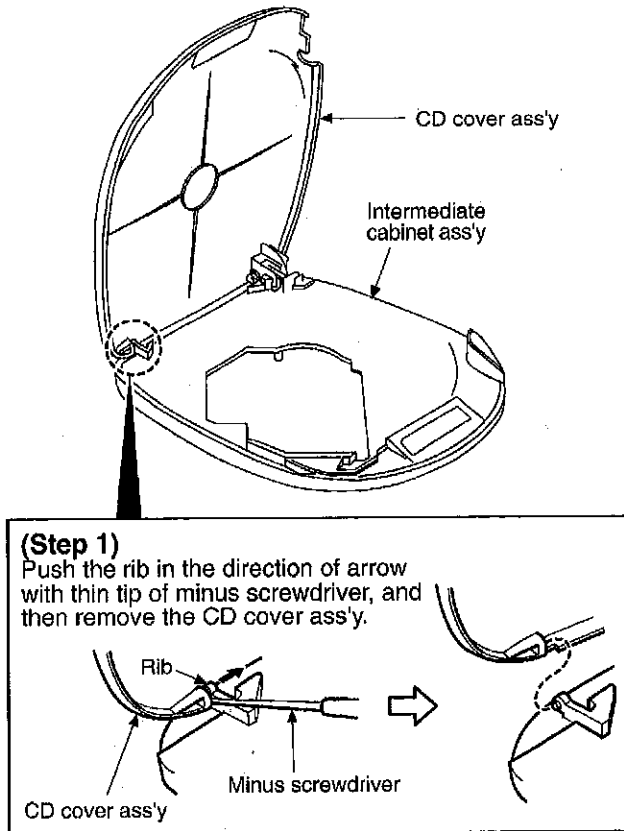

(Step 1)
Push the rib in the direction of arrow with thin tip of minus screwdriver, and then remove the CD cover ass'y.

5.3. Replacement for the traverse motor

- Follow the (Step 1) - (Step 4) of item 5.1.1.

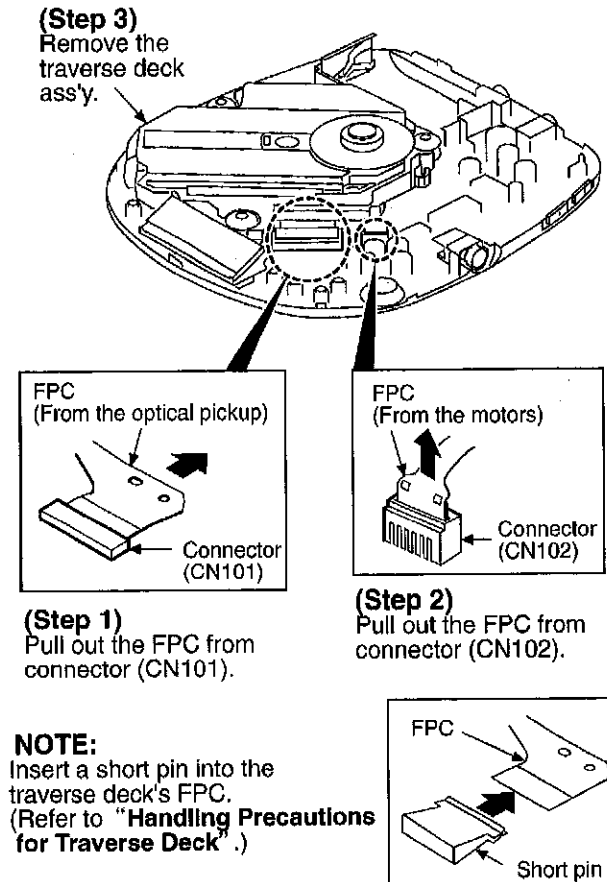

(Step 3)
Remove the traverse deck ass'y.

FPC (From the optical pickup)
Connector (CN101)

FPC (From the motors)
Connector (CN102)

(Step 1)
Pull out the FPC from connector (CN101).

(Step 2)
Pull out the FPC from connector (CN102).

NOTE:
Insert a short pin into the traverse deck's FPC. (Refer to "Handling Precautions for Traverse Deck".)

FPC
Short pin

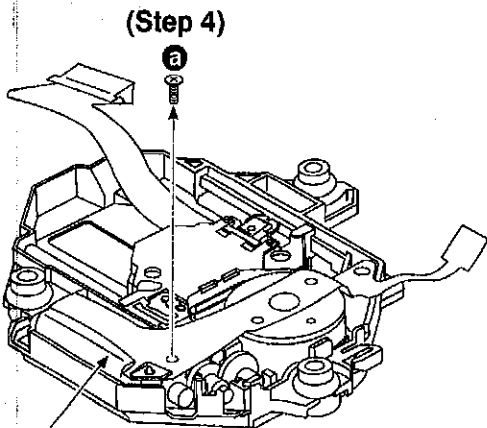

(Step 4)

(Step 5)
Remove the traverse motor.

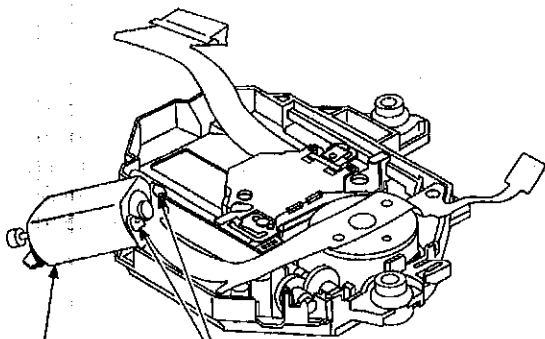

Traverse motor

(Step 6)
Unsolder the motor terminals.
(2 points)

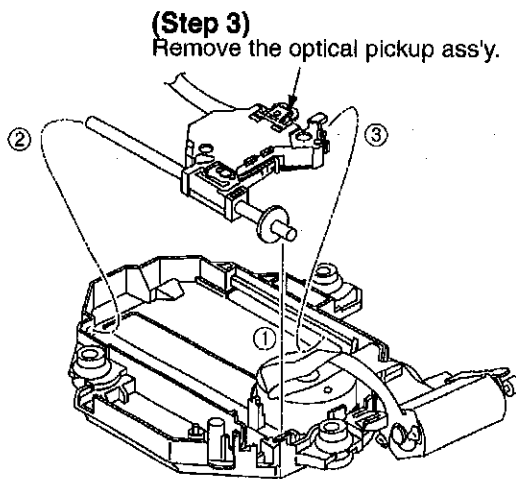

(Step 3)
Remove the optical pickup ass'y.

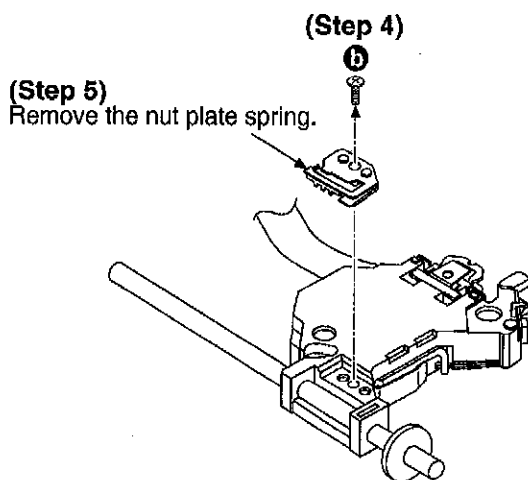

(Step 4)

(Step 5)
Remove the nut plate spring.

5.4. Replacement for the optical pickup

- Follow the (Step 1) - (Step 4) of item 5.1.1.
- Follow the (Step 1) - (Step 5) of item 5.3.

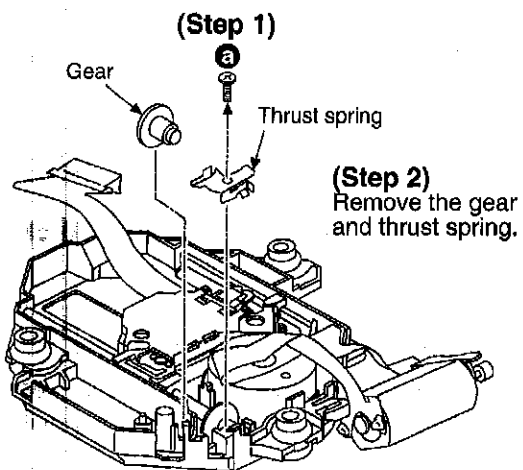

(Step 1)

(Step 2)
Remove the gear
and thrust spring.

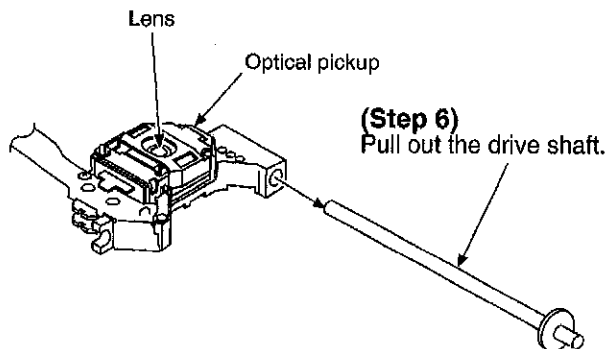

(Step 6)
Pull out the drive shaft.

- NOTE:**
1. Use care to prevent damage the optical pickup, due to the precision construction.
 2. Do not apply the grease on the lens of optical pickup.
 3. Do not touch the lens of the optical pickup.

6 Checking the Operation Problems on the Traverse Deck (Optical Pickup)

Make sure to follow the procedures below to check the operation problems of the traverse deck (optical pickup) before

replacing it.

Replace the traverse deck only after the problem is identified.

(Procedure No.) (Checking Points)

(Cause)

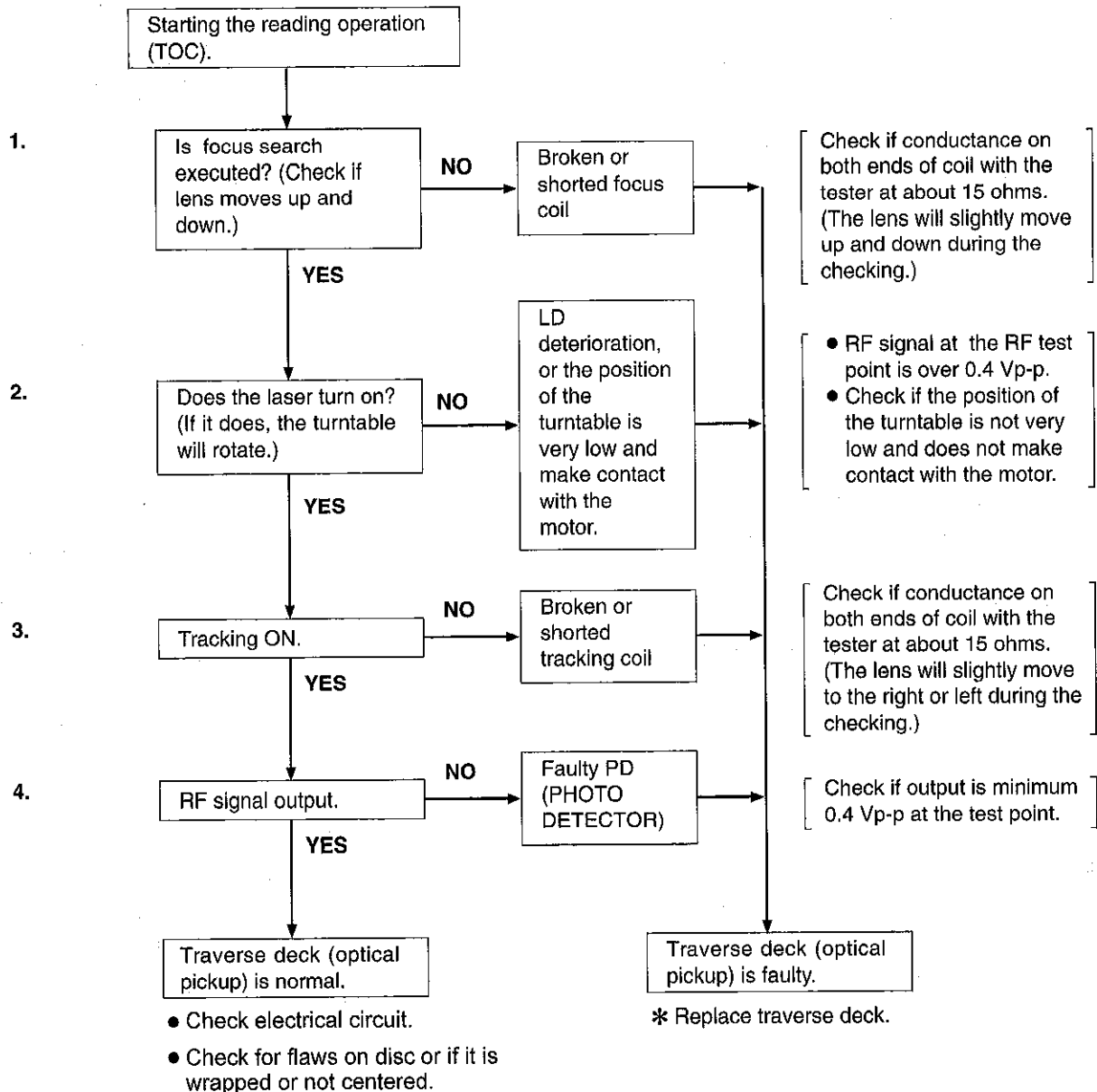

6.1. Check the operations described below on the traverse deck after replacing

6.1.1. Checking Skip Search

1. Play an ordinary musical program disc.
2. Press the skip button to check for normal skip search operation (in both the forward and reverse directions).

6.1.2. Checking Manual Search

1. Play an ordinary musical program disc.
2. Press the manual search button to check for smooth manual search operation at either low or high speed (in both the forward and reverse directions).

6.1.3. Checking Playability

1. Play the 0.7 mm black dot and the 0.7 mm wedge on the playability test disc (SZZP1054C) and verify that no sound skip or noise occurs.
2. Play the middle tracks of the uneven test disc (SZZP1056C) and verify that no sound skip or noise occurs.

7 Automatic Adjustment Results Display Function (Self-Check Function)

On the unit (SL-S214), each automatic adjustment result are displayed on the LCD. This function is convenient to check or identify which automatic adjustment circuit is incorrect.

The followings are the contents of the automatic adjustment result displays (Self-Check Function).

7.1. How to display automatic adjustment results

1. Load the test disc (SZZP1054C).
2. Press the ◀◀ (SKIP/SEARCH) and ▶▶ (SKIP/SEARCH) buttons simultaneously and hold them, and additionally press the ▶ || (PLAY/PAUSE) button.
3. Press the ■ (STOP, OPR OFF) button once.
4. An automatic adjustment result is displayed on the LCD.

7.2. Display of automatic adjustment results (Self-Check Function)

LCD Display

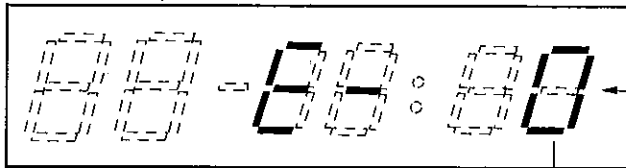

4 bits (TGC, FGC, TBC, FBC) are displayed in hexadecimal system from 0~F.

<Example>

	MSB				LSB				
	TGC	FGC	TBC	FBC	(Each bit ... TGC,FGC,TBC,FBC)				
					0 ... OK	1 ... NG			
1)	0	0	0	0	⇒ E - 0 is displayed.				
	(All adjustments are OK.) Normal								
2)	0	0	0	1	⇒ E - 1 is displayed.				
	(OK)	(OK)	(OK)	(NG)	(Focus balance adjustment is NG (incorrect).)				
3)	0	1	0	0	⇒ E - 4 is displayed.				
	(OK)	(NG)	(OK)	(OK)	(Focus gain adjustment is NG.)				
4)	1	1	1	1	⇒ E - F is displayed.				
	(All adjustments is NG.)								
5)	1	0	0	0	⇒ E - 8 is displayed.				
	(NG)	(OK)	(OK)	(OK)	(Tracking gain adjustment is NG.)				

Note: If any other disc than the test disc (SZZP1054C) is used, an E - 8 may be displayed.

<Example>

Follow the below steps when E-1 is displayed.

(Cause: Focus balance (FBC) is set beyond the limit.)

- Check if
 1. the waveform or voltage of the focus servo circuit is correct, and
 2. the optical pickup returns to the normal state by exchanging the traverse deck.

Follow the below steps when E-4 is displayed.

(Cause: Focus gain (FGC) is set beyond the limit.)

- Check if
 1. the waveform or voltage of the focus servo circuit is correct,
 2. the focus coil of the optical pickup is correct (around 15 ohms), and
 3. the optical pickup returns to the normal state by exchanging the traverse deck.

Follow the below steps when E-F is displayed.

(Cause: All adjustments (TGC,FGC,TBC,FBC) are set beyond the limit.)

- Check if
 1. the optical pickup returns to the normal state by exchanging the traverse deck, and
 2. the waveform or voltage of the servo ICs (IC101,501) are correct.

Note:

It is not always necessary to exchange the traverse deck when an error message is displayed.

Be sure to check if the circuit is defective or not before exchanging the traverse deck.

Note:

If any other disc than the test disc (SZZP1054C) is used, an error message may be displayed.

This is not a malfunction.

8 Display of Self-Diagnostic Function

This unit (SL-S214) has self-diagnostic function. It may display below-mentioned on the LCD of this unit.

- The substance of self-diagnostic display.
LCD display

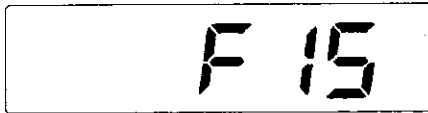

(Press PLAY and STOP button. After 15 seconds, it is displayed for 2 seconds.)

In case of this display, it may be causing for abnormally movements of traverse deck, touching failure of REST detect switch and coming off or cutting off the flexible P.C.B.. It is necessary for confirmation or repair and replacement each parts.

9 Type Illustration of ICs, Transistors and Diodes

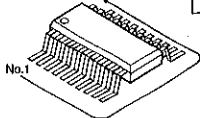
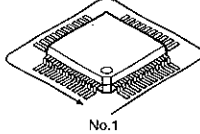
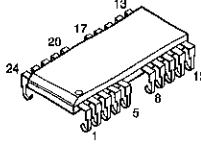
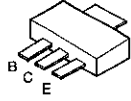
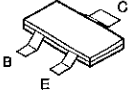
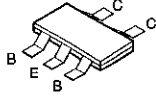
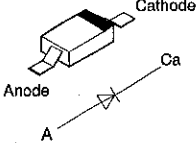
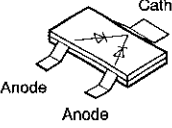
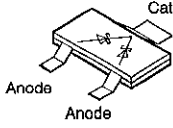
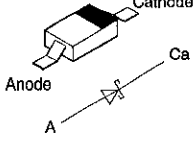
 <table border="1" data-bbox="376 575 617 674"> <tr><td>AN8746SAE1</td><td>32PIN</td></tr> <tr><td>AN8839NSBE1</td><td>28PIN</td></tr> <tr><td>NJU7082BVTE1</td><td>8PIN</td></tr> <tr><td>RS10003E2</td><td>40PIN</td></tr> </table>	AN8746SAE1	32PIN	AN8839NSBE1	28PIN	NJU7082BVTE1	8PIN	RS10003E2	40PIN	<table border="1" data-bbox="827 575 1068 625"> <tr><td>MN662782RPT1</td><td>80PIN</td></tr> <tr><td>SC502172CPB</td><td>52PIN</td></tr> </table> 	MN662782RPT1	80PIN	SC502172CPB	52PIN	<p>LH6V5CK4</p> 	<p>2SB1132T100</p> 
AN8746SAE1	32PIN														
AN8839NSBE1	28PIN														
NJU7082BVTE1	8PIN														
RS10003E2	40PIN														
MN662782RPT1	80PIN														
SC502172CPB	52PIN														
<p>2SB709ATX 2SD1328TX DTA114YUA106</p> 	<p>XN1210TX</p> 	<p>MA111TX</p> 	<p>DAN202UT106</p> 	<p>RB715FT106</p> 	<p>MA1070400L</p> 										

10 Schematic Diagram Notes

This schematic diagram may be modified at any time with the development of new technology.

Notes:

- S201:** Laser ON/OFF switch in OFF position (It turn ON with disc holder closed.)
- S202:** Rest detector switch in OFF position (It turn ON when optical pickup comes to innermost periphery.)
- S301:** Play/pause (▶ ||) switch
- S302:** Stop/operation off (■, OPR OFF) switch
- S303:** F.skip/search (▶▶▶/▶▶▶) switch
- S304:** R.skip/search (◀◀◀/◀◀◀) switch
- S305:** Repeat (↻) switch
- S306:** Memory/recall (MEMORY/RECALL) switch
- S307:** S-XBS (S-XBS) switch
- S308:** Anti-shock (A.SHOCK) switch
- S309:** Play mode selector (MODE) in NORMAL position (RESUME↔RANDOM↔NORMAL)
- S310:** Hold (HOLD) switch in OFF position
- VR701:** Headphone volume control VR (VOLUME)

The voltage values and waveforms are the reference voltage of this measured by the DC electronic voltmeter (high impedance) and oscilloscope on the basis of GND terminal (DC IN jack). Accordingly, there may arise some

errors in the voltage values and waveforms depending upon the internal impedance of the tester or measuring unit.

- The parenthesized is the voltage for test disc (1 kHz, L+R, 0 dB) in play mode, and the other, for no disc in stop mode.
- AC adaptor is used for power supply.
- Important safety notice:

Components identified by Δ mark have special characteristics important for safety.

Furthermore, special parts which have purposes of fire-retardant (resistors), high-quality sound (capacitors), low-noise (resistors), etc. are used.

When replacing any of components, be sure to use only manufacturer's specified parts shown in the parts list.

Caution!

- IC and LSI are sensitive to static electricity. Secondary trouble can be prevented by taking care during repair.
- Cover the parts boxes made of plastics with aluminum foil. Ground the soldering iron.
- Put a conductive mat on the work table.
- Do not touch the legs of IC or LSI with the fingers directly.

Voltage and signal line

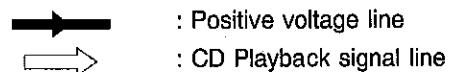

11 Schematic Diagram

→ POSITIVE VOLTAGE LINE ⇨ CD PLAYBACK SIGNAL LINE

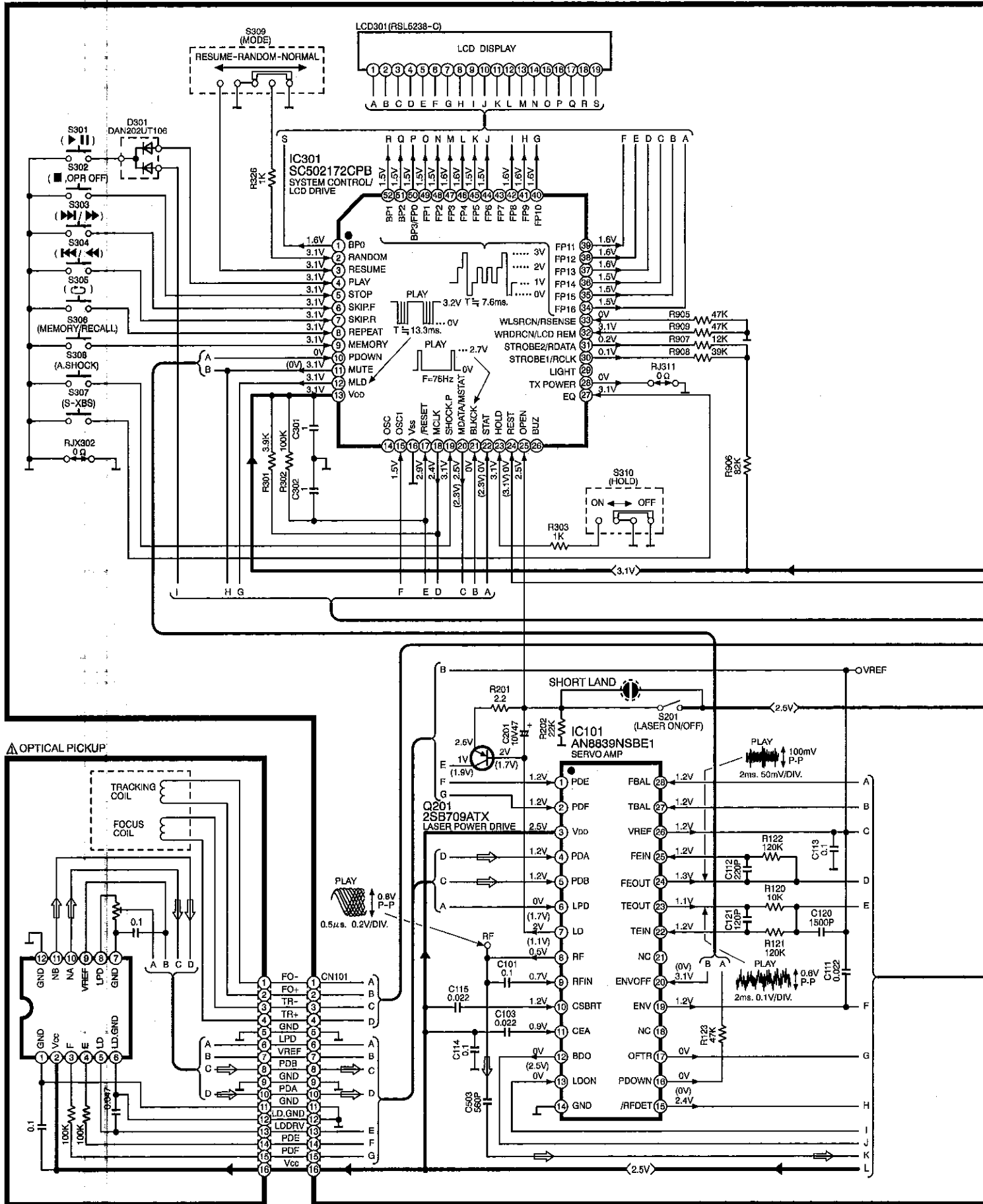

→ : POSITIVE VOLTAGE LINE

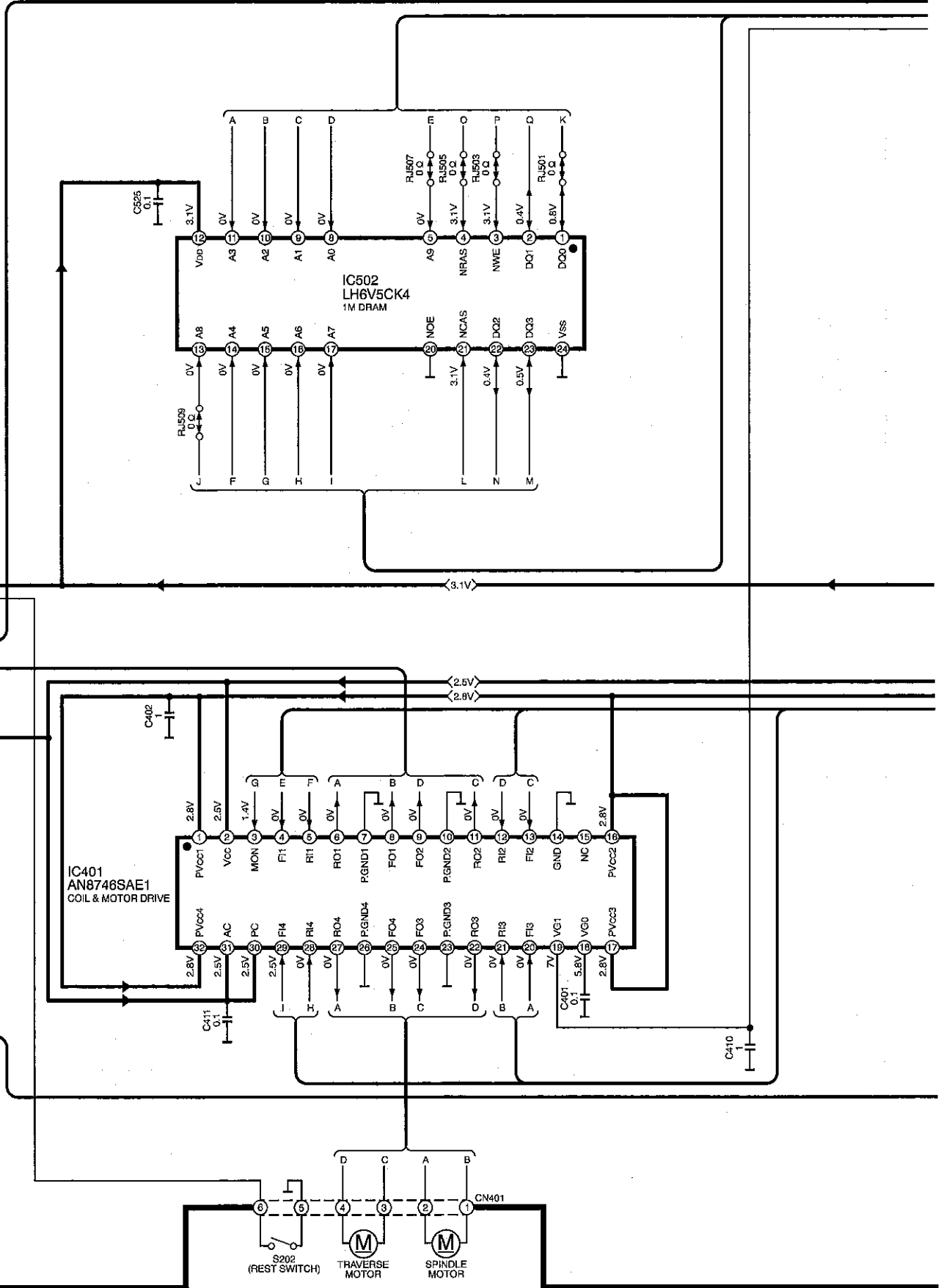

→ POSITIVE VOLTAGE LINE ⇨ CD PLAYBACK SIGNAL LINE

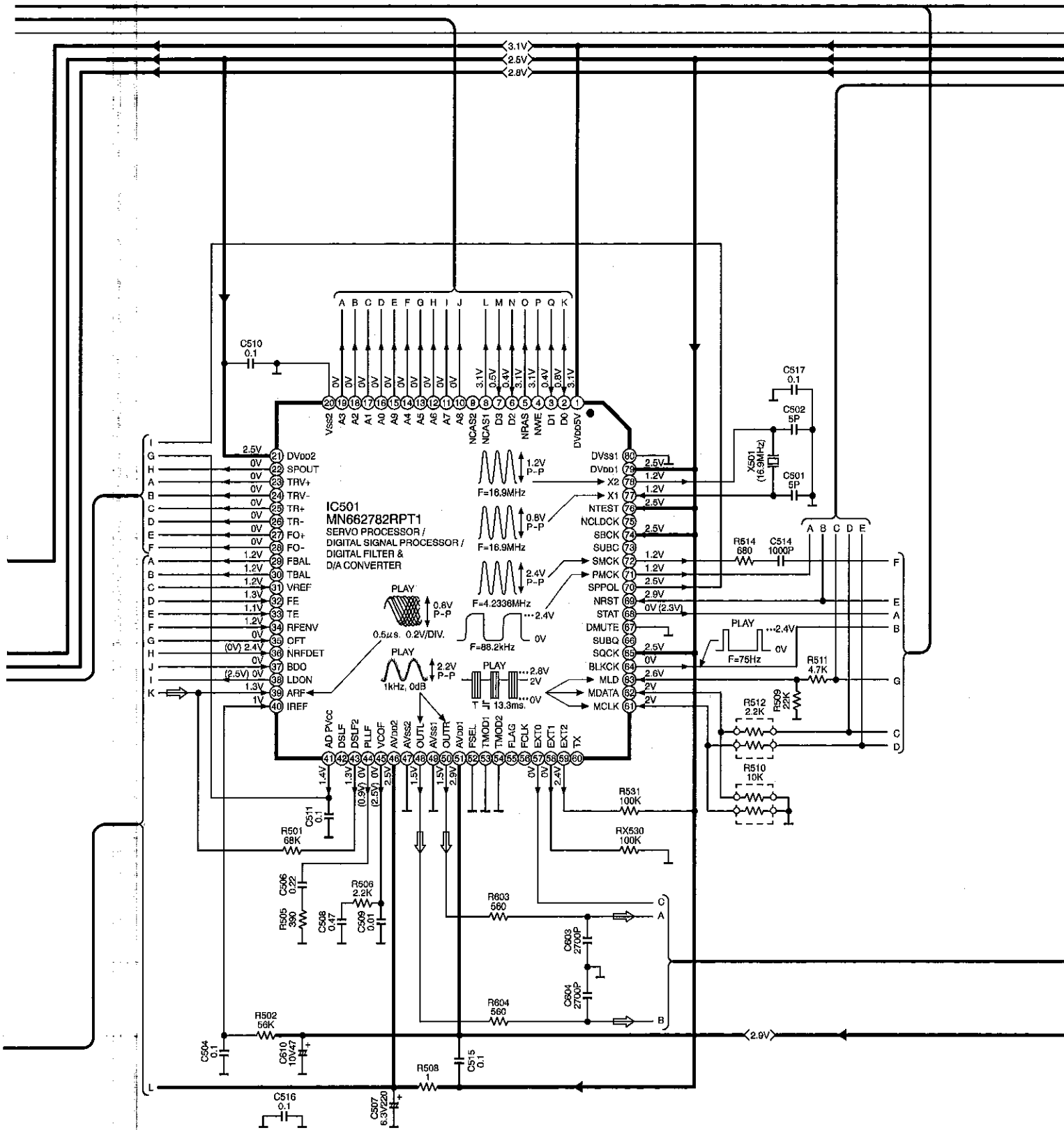

→ POSITIVE VOLTAGE LINE

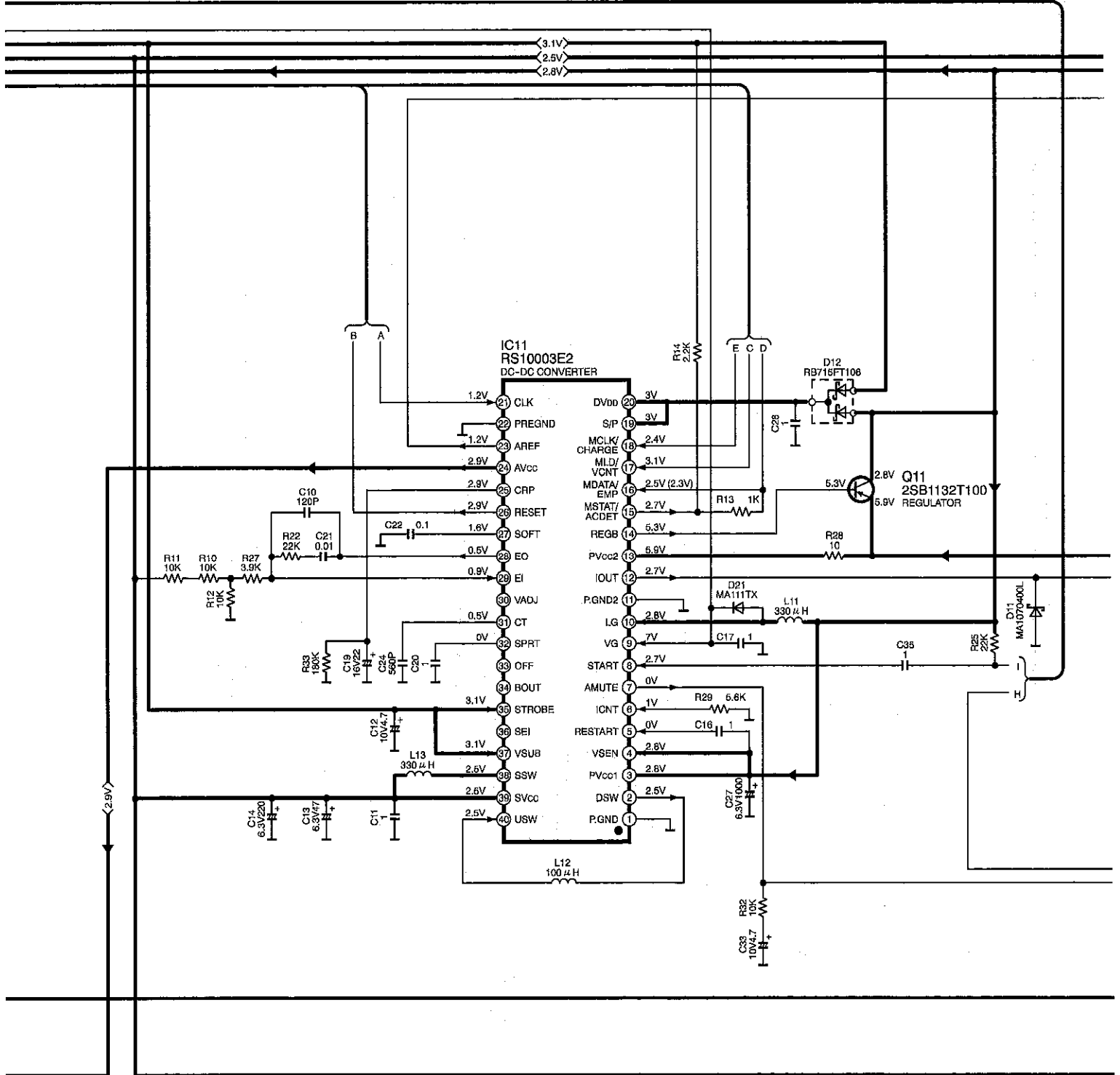



(SIDE : B)

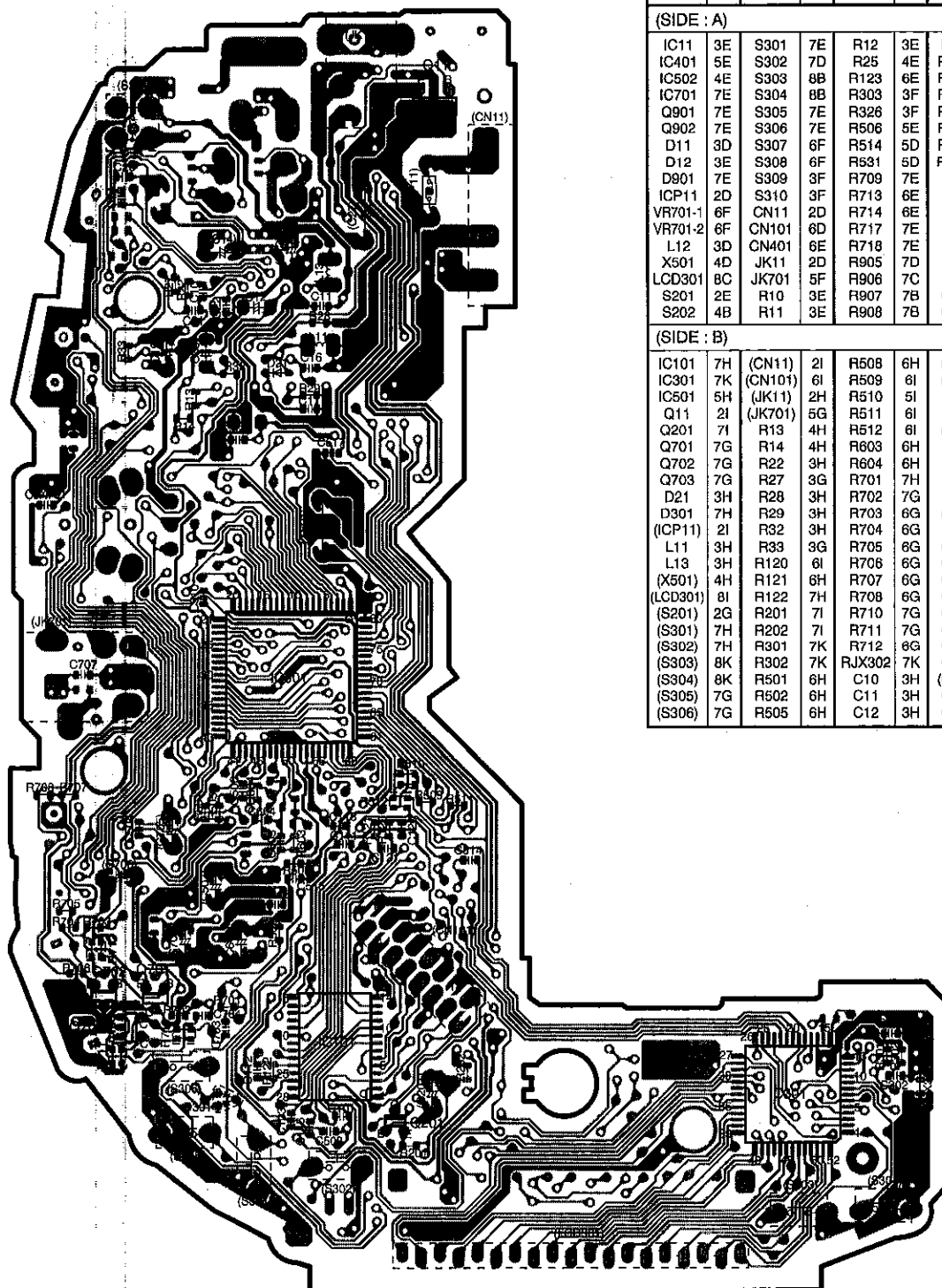

■ ELECTRICAL PARTS LOCATION

Ref. No.	Lo. No.	Ref. No.	Lo. No.	Ref. No.	Lo. No.	Ref. No.	Lo. No.	Ref. No.	Lo. No.
(SIDE : A)									
IC11	3E	S301	7E	R12	3E	R909	7C	C401	5D
IC401	5E	S302	7D	R25	4E	RJ311	6F	C402	5E
IC502	4E	S303	8B	R123	6E	RJ501	4D	C410	5D
IC701	7E	S304	8B	R303	3F	RJ503	4D	C411	5E
Q901	7E	S305	7E	R326	3F	RJ505	4E	C501	5D
Q902	7E	S306	7E	R506	5E	RJ507	4E	C502	5D
D11	3D	S307	6F	R514	5D	RJ509	4E	C507	6E
D12	3E	S308	6F	R531	5D	RX530	6E	C508	5E
D901	7E	S309	3F	R709	7E	C13	3E	C509	5E
ICP11	2D	S310	3F	R713	6E	C14	3E	C511	6E
VR701-1	6F	CN11	2D	R714	6E	C15	2D	C610	6E
VR701-2	6F	CN101	6D	R717	7E	C19	3E	C701	6E
L12	3D	CN401	6E	R718	7E	C27	3D	C702	6E
X501	4D	JK11	2D	R905	7D	C28	4E	C705	6E
LCD301	6C	JK701	5F	R906	7C	C35	4E	C706	6E
S201	2E	R10	3E	R907	7B	C114	7D		
S202	4B	R11	3E	R908	7B	C201	7D		
(SIDE : B)									
IC101	7H	(CN11)	2I	R508	6H	(C13)	3H	C503	7H
IC301	7K	(CN101)	6I	R509	6I	(C14)	3H	C504	6G
IC501	5H	(JK11)	2H	R510	5I	C16	3H	C506	6H
Q11	2I	(JK701)	5G	R511	6I	C17	4H	(C507)	6H
Q201	7I	R13	4H	R512	6I	(C19)	3G	C510	5H
Q701	7G	R14	4H	R603	6H	C20	2G	C514	6I
Q702	7G	R22	3H	R604	6H	C21	3H	C515	6H
Q703	7G	R27	3G	R701	7H	C22	3H	C516	6H
D21	3H	R28	3H	R702	7G	C24	3G	C517	4H
D301	7H	R29	3H	R703	6G	(C27)	3H	C525	4H
(ICP11)	2I	R32	3H	R704	6G	C33	3H	C603	6H
L11	3H	R33	3G	R705	6G	C101	7H	C604	6H
L13	3H	R120	6I	R706	6G	C103	7H	(C610)	6H
(X501)	4H	R121	6H	R707	6G	C111	6H	(C701)	6G
(LCD301)	8I	R122	7H	R708	6G	C112	7H	C703	7H
(S201)	2G	R201	7I	R710	7G	C113	6H	C704	7H
(S301)	7H	R202	7I	R711	7G	C115	7H	(C705)	6G
(S302)	7H	R301	7K	R712	6G	C120	6I	(C706)	6G
(S303)	8K	R302	7K	RJX302	7K	C121	6I	C707	5G
(S304)	8K	R501	6H	C10	3H	(C201)	7I	CJX701	4G
(S305)	7G	R502	6H	C11	3H	C301	7K		
(S306)	7G	R505	6H	C12	3H	C302	7K		

MN662782RPT1

IC501

SERVO PROCESSOR / DIGITAL SIGNAL PROCESSOR
DIGITAL FILTER & D/A CONVERTER

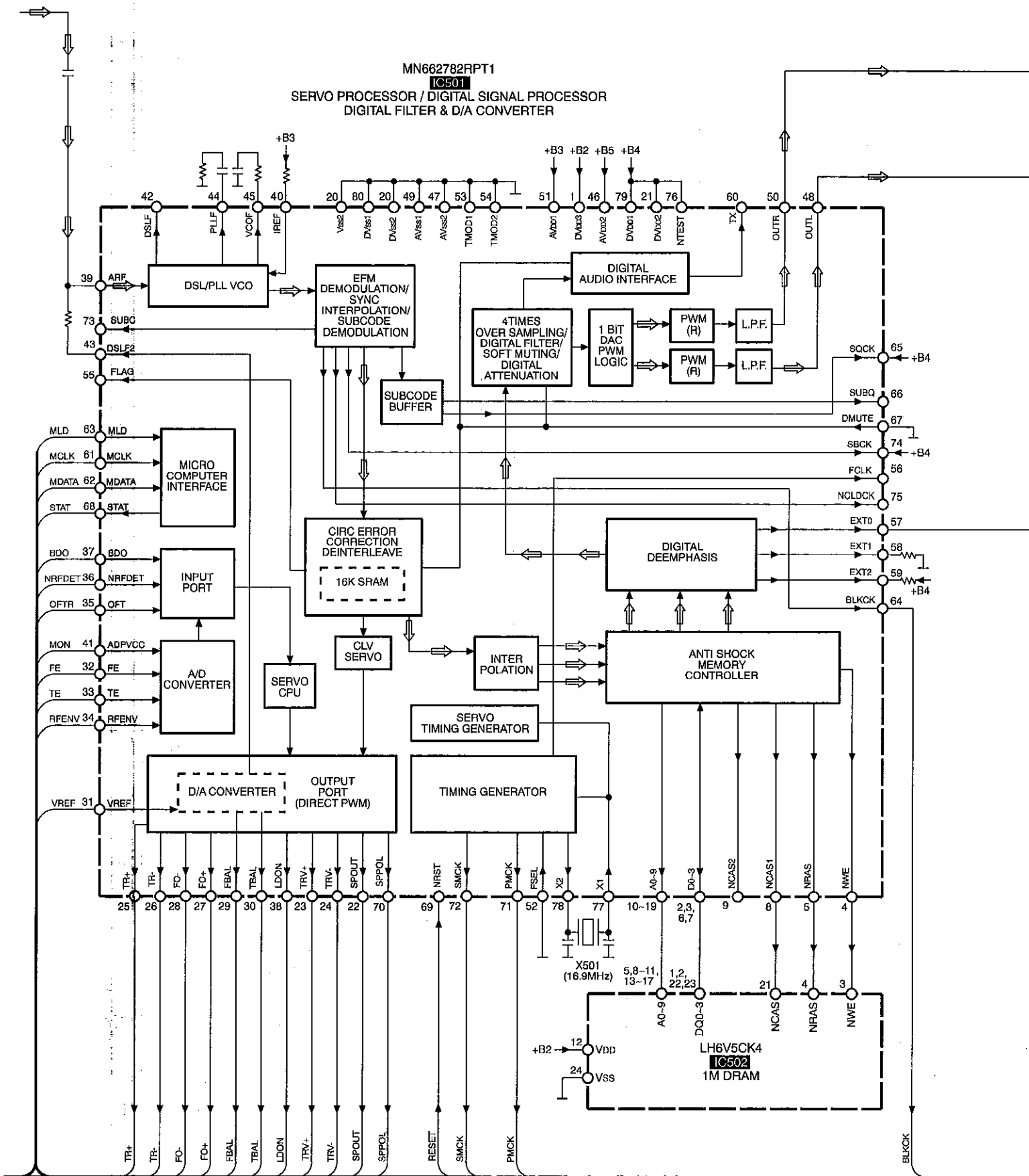

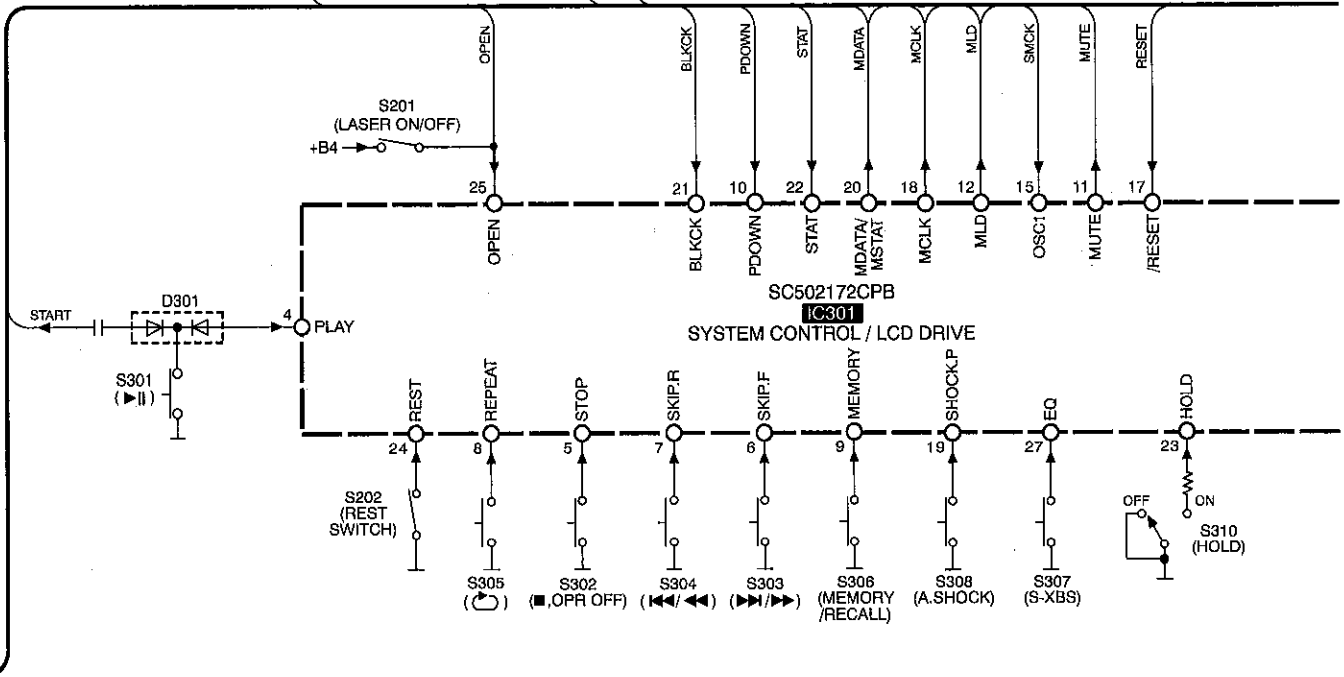
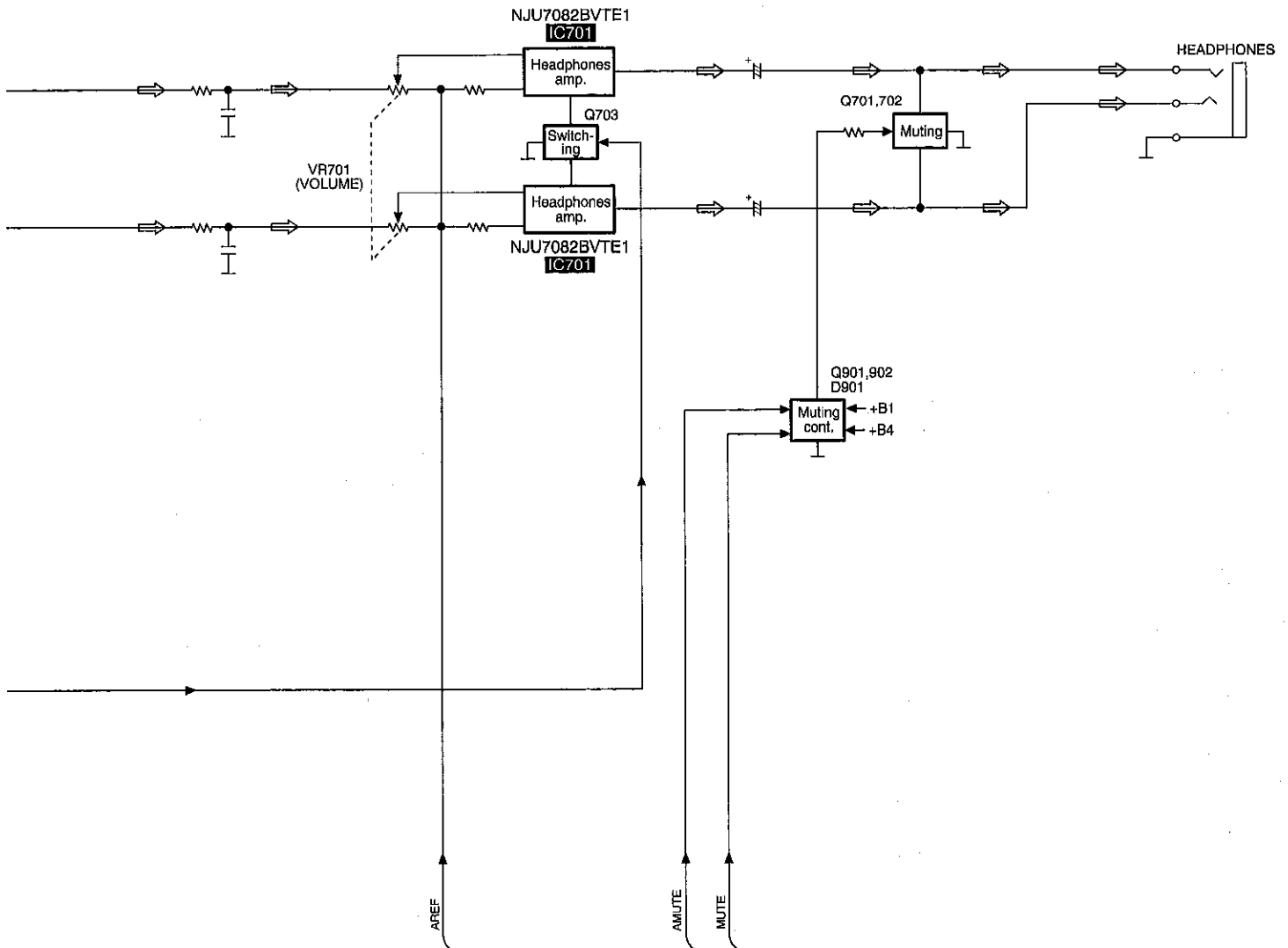

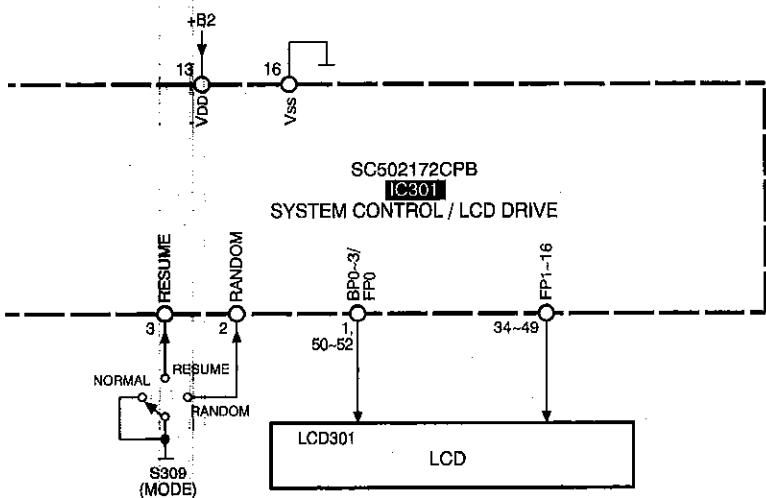
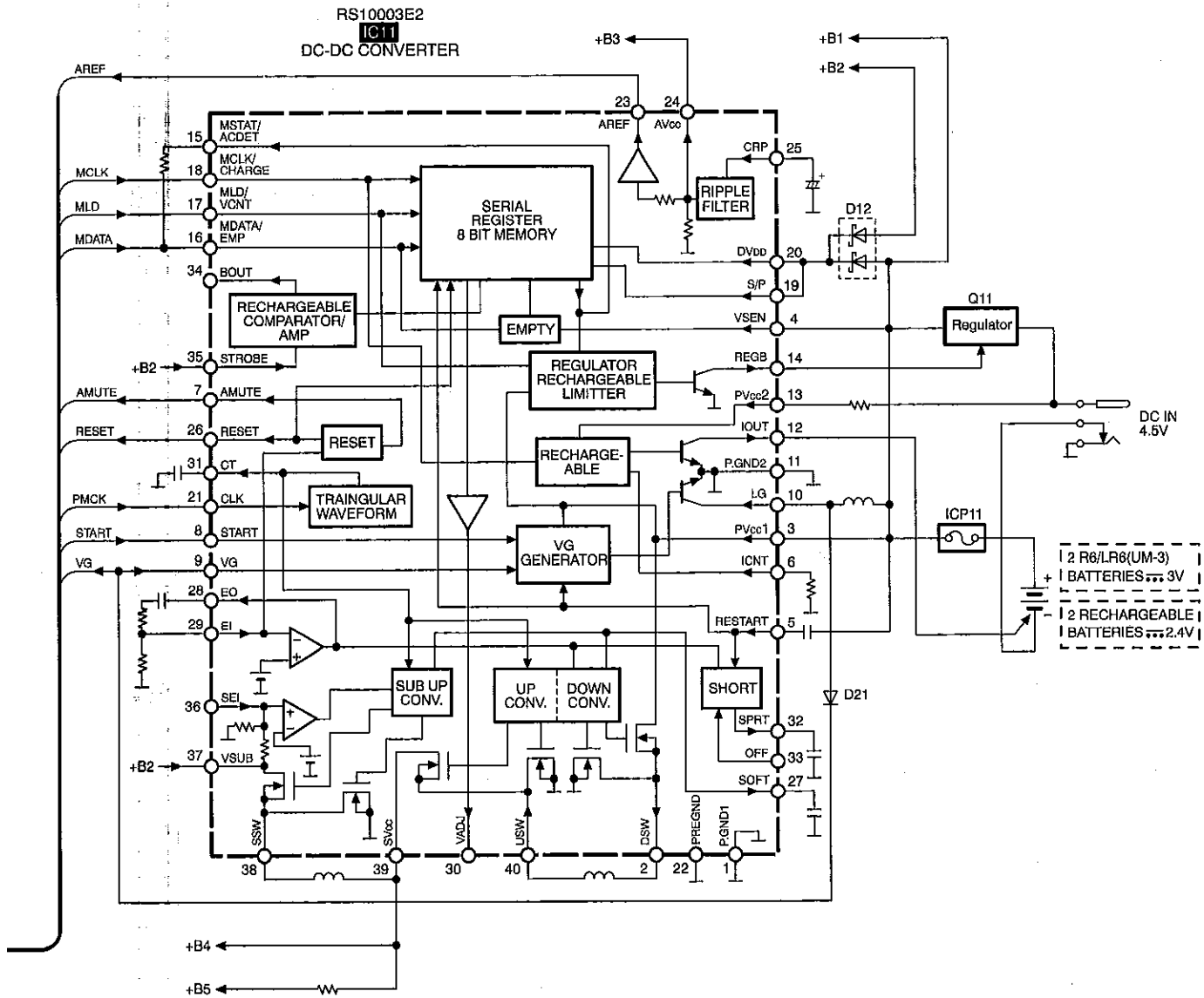

Note:
 • ⇨ : CD PLAYBACK SIGNAL LINE

14 Terminal Function of ICs

14.1. IC11 (RS10003E2): DC-DC Converter

Pin No.	Terminal Name	I/O	Function
1	P.GND1	-	GND
2	DSW	O	DC-DC converter coil drive terminal
3	PV _{CC1}	I	Power supply terminal
4	VSEN	I	Empty supply terminal (Power supply terminal)
5	RESTART	I	DC-DC converter drive terminal
6	ICNT	I	Charge current setting terminal
7	AMUTE	O	Muting signal output
8	START	I	DC-DC converter start terminal
9	VG	I	Power supply terminal
10	LG	I	Connected to power supply
11	P.GND2	-	GND
12	IOUT	O	Charge signal output
13	PV _{CC2}	I	Power supply terminal
14	REGB	O	Regulator drive signal output
15	MSTAT/ ACDET	O	DC jack detect signal output
16	MDATA/ EMP	I	Decline voltage detect signal input
17	MLD/ VCNT	I	Regulator voltage select input
18	MCLK/ CHARGE	I	Charge ON/OFF terminal
19	S/P	I	Serial/Parallel select terminal (Connected to power supply)
20	DV _{DD}	I	Power supply terminal
21	CLK	I	Clock signal input
22	PREGND	-	GND
23	AREF	O	Audio reference output
24	AV _{CC}	O	Ripple filter output
25	CRP	I	Connected to capacitor
26	RESET	O	Reset detect signal output
27	SOFT	O	Soft start setting terminal (Connected to capacitor)
28	EO	O	DC-DC converter error amp output
29	EI	I	DC-DC converter error amp input
30	VADJ	-	DC-DC converter variable output (Not used, open)
31	CT	O	Triangular wave output (Connected to capacitor)
32	SPRT	O	Power off time-constant setting terminal (Connected to capacitor)
33	OFF	-	DC-DC converter off terminal (Not used, open)
34	BOUT	-	Amp output terminal (Not used, open)
35	STROBE	I	Strobe signal input
36	SEI	-	Sub DC-DC converter, error amp input (Not used, open)
37	VSUB	I	Power supply terminal
38	SSW		
39	SV _{CC}		
40	USW	I	DC-DC converter coil drive terminal

14.2. IC101 (AN8839NSBE1): Servo Amp

Pin No.	Terminal Name	I/O	Function
1	PDE	I	Tracking signal input (1)
2	PDF	I	Tracking signal input (2)
3	V _{DD}	I	Power supply terminal
4	PDA	I	Focus signal input (1)

Pin No.	Terminal Name	I/O	Function
5	PDB	I	Focus signal input (2)
6	LPD	I	APC amp input terminal
7	LD	O	APC amp output terminal
8	RF	O	RF summing output terminal
9	RF IN	I	RF signal input
10	CSBRT	I	Capacitor connection terminal for OFTR
11	GEA	I	Capacitor connection terminal for H.P.F. amp
12	BDO	O	Dropout signal output (H: Dropout)
13	LDON	I	APC control signal input
14	GND	-	GND
15	/RFDET	O	RF detect signal output (L: Detect)
16	PDOWN	O	Power down signal output
17	OFTR	O	Off track signal output (H: Off track)
18	NC	-	Not used, open
19	ENV	O	RF envelope signal output
20	ENVOFF	I	ENV control signal input
21	NC	-	Not used, open
22	TEIN	I	Tracking error amp input
23	TEOUT	O	Tracking error amp output
24	FEOUT	O	Focus error amp output
25	FEIN	I	Focus error amp input
26	VREF	O	Reference voltage output
27	TBAL	I	Tracking balance signal input
28	FBAL	I	Focus balance signal input

14.3. IC301 (SC502172CPB): System Control/LCD Drive

Pin No.	Terminal Name	I/O	Function
1	BP0	O	LCD segment signal output
2	RANDOM	I	RANDOM switch signal input
3	RESUME	I	RESUME switch signal input
4	PLAY	I	PLAY key signal input
5	STOP	I	STOP key signal input
6	SKIP.F	I	SKIP.F key signal input
7	SKIP.R	I	SKIP.R key signal input
8	REPEAT	I	REPEAT key signal input
9	MEMORY	I	MEMORY key signal input
10	PDOWN	I	Head amp OFF input
11	MUTE	O	Hard muting output terminal
12	MLD	O	Serial command latch output
13	V _{DD}	I	Power supply terminal
14	OSC	-	System clock input (Not used, open)
15	OSC1	I	System clock input
16	V _{SS}	-	GND
17	/RESET	I	Reset signal input
18	MCLK	O	Serial command output terminal
19	SHOCK.P	I	SHOCK.P key signal input
20	MDATA/ MSTAT	O	Command data output
21	BLKCK	I	Block clock signal input
22	STAT	I	Status signal input
23	HOLD	I	HOLD switch signal input
24	REST	I	REST (innermost position) detection input
25	OPEN	I	CD cover open detect signal input
26	BUZ	-	Beep control output terminal (Not used, open)
27	EQ	I	S-XBS key signal input
28	TX POWER	O	Optical out power control signal output
29	LIGHT	-	LED power supply output (Not used, open)

Pin No.	Terminal Name	I/O	Function
30	STROBE1/ RCLK	O	Remote control clock signal output
31	STROBE2/ RDATA	O	Remote control data signal output
32	WRDRCN/ LCDREM	I	Remote control data signal input (Connected to GND)
33	WLSRCN/ RSENSE	I	Remote control sense signal input (Connected to GND)
34 42	FP16 FR8	O	LCD segment signal output
43	FP7	-	LCD segment signal output (Not used, open)
44 49	FP6 FP1	O	LCD segment signal output
50	BP3/FP0	O	LCD segment signal output
51	BP2	O	LCD segment signal output
52	BP1		

14.4. IC501 (MN662782RPT1): Servo Processor/Digital Signal Processor/Digital Filter/ D/A Converter

Pin No.	Terminal Name	I/O	Function
1	DV _{DD} 5V	I	Power supply terminal
2	D0	I/O	Data 0 input/output terminal
3	D1	I/O	Data 1 input/output terminal
4	NWE	O	Write enable signal output
5	NRAS	O	RAS control signal output
6	D2	I/O	Data 2 input/output terminal
7	D3	I/O	Data 3 input/output terminal
8	NCAS1	O	CAS control 1 signal output
9	NCAS2	-	Not used, open
10 14	A8 A4	O	Address 8 - 4 signal output
15	A9	O	Address 9 signal output
16 19	A0 A3	O	Address 0 - 3 signal output
20	V _{SS}	-	GND
21	DV _{DD} 2	I	Power supply terminal
22	SPOUT	O	Spindle motor drive signal output
23	TRV+	O	Traverse motor drive signal output
24	TRV-	O	Traverse motor drive signal output
25	TR+	O	Tracking coil drive signal output
26	TR-	O	Tracking coil drive signal output
27	FO+	O	Focus coil drive signal output
28	FO-	O	Focus coil drive signal output
29	FBAL	O	Focus balance adj. signal output
30	TBAL	O	Tracking balance adj. signal output
31	VREF	I	Reference voltage input terminal
32	FE	I	Focus error signal input
33	TE	I	Tracking error signal input
34	RFENV	I	RF envelope signal input
35	OFT	I	Off track signal input (H: Off track)
36	NRFDET	I	RF detect signal input (L: Detect)
37	BDO	I	Drop out signal input (H: Drop out)
38	LDON	O	Laser on signal output (H: ON)
39	ARF	I	RF signal input
40	IREF	I	Reference current input terminal
41	AD PV _{CC}	O	A/D converter reference voltage output
42	DSLIF	-	DSL loop filter output (Not used, open)
43	DSLIF2	O	DSL unbalance current correction output

Pin No.	Terminal Name	I/O	Function
44	PLLIF	O	PLL loop filter output
45	VCOF	O	Loop filter output
46	AV _{DD} 2	I	Power supply terminal
47	AV _{SS} 2	-	GND
48	OUTL	O	Audio L ch output
49	AV _{SS} 1	-	GND
50	OUTR	O	Audio R ch output
51	AV _{DD} 1	I	Power supply terminal
52	FSEL	-	Noise filter select terminal (H: ON, L: OFF)
53	TMOD1	-	Terminal mode select 1 terminal (L: Normal)
54	TMOD2	-	Terminal mode select 2 terminal (L: Normal)
55	FLAG	-	Flag signal output (Not used, open)
56	FCLK	-	Frame clock signal output (Not used, open)
57	EXT0	O	Expansion port 0 output
58	EXT1	O	Expansion port 1 output
59	EXT2	O	Expansion port 2 output
60	TX	-	Digital audio interface signal output (Not used, open)
61	MCLK	I	Micon command clock signal input
62	MDATA	I	Micon command data signal input
63	MLD	I	Micon command load signal input (L: Load)
64	BLKCK	O	Sub code block clock signal output (f _{BLKCK} =75 kHz)
65	SQCK	I	Sub code Q resistor clock input
66	SUBQ	-	Sub code Q data output (Not used, open)
67	DMUTE	I	Muting signal input (H: Mute)
68	STAT	O	Status signal output
69	NRST	I	Reset signal input (L: Reset)
70	SPPOL	O	Spindle motor drive signal output
71	PMCK	O	Clock signal output (88.2 kHz)
72	SMCK	O	Clock signal output (4.2336 MHz)
73	SUBC	-	Sub code signal output (Not used, open)
74	SBCK	I	Sub code output clock input
75	NCLDCK	-	Sub code frame clock output (Not used, open)
76	NTEST	I	Test terminal
77	X1	I	Crystal oscillator input (f=16.9 MHz)
78	X2	O	Crystal oscillator output (f=16.9 MHz)
79	DV _{DD} 1	I	Power supply terminal
80	DV _{SS} 2	-	GND

15 Replacement Parts List

Notes:

- Important safety notice:
Components identified by Δ mark have special characteristics important for safety.
Furthermore, special parts which have purposes of fire-retardant (resistors), high-quality sound (capacitors), low-noise (resistors), etc. are used.
When replacing any of components, be sure to use only manufacture's specified parts shown in the parts list.
- The marks in Remarks indicates as follow.
 - Language of instruction manual.
 - <IA>: English
 - <IB>: English, German, French, Spanish, Swedish, Italian
 - <IC>: Netherlands, Russian, Polish, Danish, Czech
 - Specify the area and colour.
 - (E): Great Britain.
 - (EG): Europe and CIS.
 - [A]: Blue Type
 - [S]: Silver Type
- The marking [RTL] indicates that Retention Time is Limited for this item. After the discontinuation of this assembly in production, the item will continue to be available for a specific period of time. The retention period of availability is dependent on the type of assembly, and in accordance with the laws governing part and product retention. After the end of this period, the assembly will no longer be available.
- All parts are supplied by MESA.

Ref. No.	Part No.	Part Name & Description	Pcs	Remarks
1	RGN1922-K	NAME PLATE	1	(E)
1	RGN1909-K	NAME PLATE	1	(EG)
2	RQLS0196	LASER LABEL	1	
3	RGV0200-K	KNOB, RANDAM-HOLD	2	
4	RJC93020	BATTERY TERMINAL	1	
5	RKA0112-K	FOOT	2	
6	RKS0300D-H	BOTTOM CABINET	1	
7	RGPO700-Q	LCD WINDOW	1	
8	RGU1705-H	BUTTON 1	1	
9	RGU1706-H	BUTTON 2	1	
10	RYF0505H-A	CD LID ASS'Y	1	[A]
10	RYF0505H-S	CD LID ASS'Y	1	[S]
11	XQN14+BG4FZ	SCREW	3	
12	RYK0896B-H	CABINET ASS'Y	1	
12-1	RGU1707-1H	BUTTON, OPEN	1	
12-2	RGU1708-H	BUTTON, A-SHOCK/S-XBS	1	
12-3	RKW0569-Q1	LCD PANEL	1	
12-4	RME0287	SPRING	1	
12-5	RML0472	STOPPER	1	
13	RKK0102-H	BATTERY COVER	1	
14	XTN17+6GFZ	SCREW	4	
201	RAE0145Z	TRAVERSE DECK	1	Δ
201-1	RAF0142A	OPTICAL PICK-UP	1	Δ
201-2	RDG0305	GEAR 1	1	
201-3	RDG0306	GEAR 2	1	
201-4	RJB2106A	FFC	1	
201-5	RMG0449-H	RUBBER	3	
201-6	RMC0264	SPRING PLATE	1	
201-7	RXQ0482	NUT PLATE	1	
201-8	RXQ0525	MOTOR	1	

Ref. No.	Part No.	Part Name & Description	Pcs	Remarks
201-9	SNSD38	SCREW	1	
201-10	XQN17+BG45	SCREW	1	
201-11	XQN17+CG45	SCREW	1	
201-12	XQN2+BG55	SCREW	1	
A1	RFEA419E-M	AC ADAPTOR	1	(EG) Δ
A2	RFEV334P-KS	STEREO INSIDEPHONES	1	
A3	RQA0117	WARRANTY CARD	1	
A4	RQCB0169	SERVICE CENTER LIST	1	
A5	RQT5483-B	INSTRUCTION MANUAL	1	(E) <IA>
A6	RQT5443-E	INSTRUCTION MANUAL	1	(EG) <IB>
A7	RQT5444-H	INSTRUCTION MANUAL	1	(EG) <IC>
C10	ECUV1H121JCV	50V 120P	1	
C11	ECUVNA105ZFV	10V 1U	1	
C12	RCST1AY475RE	10V 4.7U	1	
C13	RCE0JSC470IX	6.3V 47U	1	
C14	RCE0JKA221IG	6.3V 220U	1	
C15	ECUZNC104ZEV	16V 0.1U	1	
C16,17	ECUVNA105ZFV	10V 1U	2	
C19	ECA1CAK220XH	16V 22U	1	
C20	ECUVNA105ZFV	10V 1U	1	
C21	ECUVNH103KBV	50V 0.01U	1	
C22	ECUZNC104ZEV	16V 0.1U	1	
C24	ECUV1H561KBV	50V 560P	1	
C27	RCE0JRC102BG	6.3V 1000U	1	
C28	ECUVNA105ZFV	10V 1U	1	
C33	RCST1AY475RE	10V 4.7U	1	
C35	ECUVNJ105KBV	63V 1U	1	
C101	ECUVNC104KBV	16V 0.1U	1	
C103	ECUVNE223KBV	25V 0.022U	1	
C111	ECUVNE223KBV	25V 0.022U	1	
C112	ECUV1H221KBV	50V 220P	1	
C113,14	ECUZNC104ZEV	16V 0.1U	2	
C115	ECUVNE223KBV	25V 0.022U	1	
C120	ECUV1H152KBV	50V 1500P	1	
C121	ECUV1H121JCV	50V 120P	1	
C201	ECEA1AKS470	10V 47U	1	
C301,02	ECUVNA105ZFV	10V 1U	2	
C401	ECUZNC104ZEV	16V 0.1U	1	
C402	ECUVNA105ZFV	10V 1U	1	
C410	ECUVNA105ZFV	10V 1U	1	
C411	ECUZNC104ZEV	16V 0.1U	1	
C501,02	ECUV1H050CCV	50V 5P	2	
C503	ECUV1H561KBV	50V 560P	1	
C504	ECUZNC104ZEV	16V 0.1U	1	
C506	ECUVNA224KBV	10V 0.22U	1	
C507	RCE0JKA221IG	6.3V 220U	1	
C508	ECUV0J474KBV	6.3V 0.47U	1	
C509	ECUVNH103KBV	50V 0.01U	1	
C510,11	ECUZNC104ZEV	16V 0.1U	2	
C514	ECUV1H102KBV	50V 1000P	1	
C515-17	ECUZNC104ZEV	16V 0.1U	3	
C525	ECUZNC104ZEV	16V 0.1U	1	
C603,04	ECUV1H272KBV	50V 2700P	2	
C610	ECEA1AKS470	10V 47U	1	
C701	ECEA1AKS470	10V 47U	1	
C702	ECUZNC104ZEV	16V 0.1U	1	
C703,04	ECUVNJ105KBV	63V 1U	2	
C705,06	ECA0JAK221XH	6.3V 220U	2	
C707	ECUZNC104ZEV	16V 0.1U	1	
CN11	RJH8303-3	BATTERY TERMINAL	1	
CN101	RJS2A4716M1	CONNECTOR (16P)	1	
CN401	RJS2A5106T1	CONNECTOR (6P)	1	
D11	MA1070400L	DIODE	1	
D12	MA741WKTX	DIODE	1	
D21	MA111TX	DIODE	1	

Ref. No.	Part No.	Part Name & Description	Pcs	Remarks
D301	MA142WKT	DIODE	1	
D901	MA142WKT	DIODE	1	
IC11	RS10003E2	IC	1	
IC101	AN8839NSBE2	IC	1	
IC301	SC502172CPB	IC	1	
IC401	AN8746SAE1	IC	1	
IC501	MN662782RPT1	IC	1	
IC502	LH6V5CK4	IC	1	
IC701	NJU7082BVTE1	IC	1	
ICP11	UNH000700A	IC PROTECTOR	1	△
JK11	RJJ43K09-C	DC IN	1	
JK701	RJJ33TK07-C	HEADPHONE	1	
RJX302	ERJ3GEYOR00V	CHIP JUMPER	1	
CJX701	ECUV1H101KC	50V 100P	1	
L11	RLQU331KT-W	COIL	1	
L12	RLQ8101KT1-T	COIL	1	
L13	RLQU331KT-W	COIL	1	
LCD301	RSL5238-C	LCD	1	
P1	RPK1393	GIFT BOX	1	(E)
P1	RPK1404	GIFT BOX	1	(EG)
P2	RPQ0753	SPACER	1	
P3	RPQ0836-3	PAD	1	
P4	RPF0046	PROTECTION BAG (F.B.)	1	
P5	RPF0111	PROTECTION BAG (UNIT)	1	
PCB1	REP2977C-M	P.C.B. ASSY.	1	[RTL]
Q11	2SB1132T100	TRANSISTOR	1	
Q201	2SB709ATX	TRANSISTOR	1	
Q701, 02	2SD1328QRSTX	TRANSISTOR	2	
Q703	XN1210TX	TRANSISTOR	1	
Q901	DPA114YUA106	TRANSISTOR	1	
Q902	XN1210TX	TRANSISTOR	1	
R10-12	ERJ3GEYD103V	1/16W 10K	3	
R13	ERJ3GEYJ102V	1/16W 1K	1	
R14	ERJ3GEYJ222V	1/16W 2.2K	1	
R22	ERJ3GEYJ223V	1/16W 22K	1	
R25	ERJ3GEYJ223V	1/16W 22K	1	
R27	ERJ3GEYJ392V	1/16W 3.9K	1	
R28	ERJ3GEYJ100V	1/16W 10	1	
R29	ERJ3GEYJ562V	1/16W 5.6K	1	
R32	ERJ3GEYJ103Z	1/16W 10K	1	
R33	ERJ3GEYD184V	1/16W 180K	1	
R113	ERJ3GEYOR00V	CHIP JUMPER	1	
R120	ERJ3GEYJ103Z	1/16W 10K	1	
R121, 22	ERJ3GEYJ124V	1/16W 120K	2	
R123	ERJ3GEYJ473V	1/16W 47K	1	
R201	ERJ3GEYJ2R2V	1/16W 2.2	1	
R202	ERJ3GEYJ223V	1/16W 22K	1	
R301	ERJ3GEYJ392V	1/16W 3.9K	1	
R302	ERJ3GEYJ104Z	1/16W 100K	1	
R303	ERJ3GEYJ102V	1/16W 1K	1	
R311	ERJ3GEYOR00V	CHIP JUMPER	1	
R326	ERJ3GEYJ102V	1/16W 1K	1	
R501	ERJ3GEYJ683V	1/16W 68K	1	
R502	ERJ3GEYJ563V	1/16W 56K	1	
R505	ERJ3GEYJ391V	1/16W 390	1	
R506	ERJ3GEYJ222V	1/16W 2.2K	1	
R508	ERJ3GEYJ1R0V	1/16W 1	1	
R509	ERJ3GEYJ223V	1/16W 22K	1	
R510	EXBV4V103JV	1/32W 10K	1	
R511	ERJ3GEYJ472V	1/16W 4.7K	1	
R512	EXBV4V222JV	1/32W 2.2K	1	
R514	ERJ3GEYJ681V	1/16W 680	1	
R531	ERJ3GEYJ104Z	1/16W 100K	1	
R603, 04	MCR03PZHJ561	1/16W 560	2	

Ref. No.	Part No.	Part Name & Description	Pcs	Remarks
R701, 02	ERJ3GEYJ104Z	1/16W 100K	2	
R703, 04	ERJ3GEYJ220V	1/16W 22	2	
R705, 06	ERJ3GEYJ1R5V	1/16W 1.5	2	
R707, 08	ERJ3GEYJ472V	1/16W 4.7K	2	
R709	EXBV4V392J	1/32W 3.9K	1	
R710	EXBV4V123J	1/32W 12K	1	
R711	EXBV4V103JV	1/32W 10K	1	
R712	EXBV4V331JV	1/32W 330	1	
R713, 14	ERJ3GEYJ562V	1/16W 5.6K	2	
R717, 18	ERJ3GEYJ562V	1/16W 5.6K	2	
R905	ERJ3GEYJ473V	1/16W 47K	1	
R906	ERJ3GEYJ823V	1/16W 82K	1	
R907	ERJ3GEYJ123V	1/16W 12K	1	
R908	ERJ3GEYJ393V	1/16W 39K	1	
R909	ERJ3GEYJ473V	1/16W 47K	1	
RJ311	ERJ3GEYOR00V	CHIP JUMPER	1	
RJ501	ERJ3GEYOR00V	CHIP JUMPER	1	
RJ503	ERJ3GEYOR00V	CHIP JUMPER	1	
RJ505	ERJ3GEYOR00V	CHIP JUMPER	1	
RJ507	ERJ3GEYOR00V	CHIP JUMPER	1	
RJ509	ERJ3GEYOR00V	CHIP JUMPER	1	
RX530	ERJ3GEYJ104Z	1/16W 100K	1	
S201	ESE11SV6	SW, LASER	1	
S202	ESE11HS4	SW, REST	1	
S301-06	EVQ11G05R	SW, PUSH	6	
S307, 08	EVQPUM02K	SW, S-XBS/A-SHOCK	2	
S309	RSS3A007-1A	SW, MODE	1	
S310	RSS2A010-1A	SW, HOLD	1	
VR701	EVUTUFB11C54	V. R., VOLUME	1	
X501	RSXZ16M9M01T	OSCILLATOR	1	

16 Cabinet Parts Location

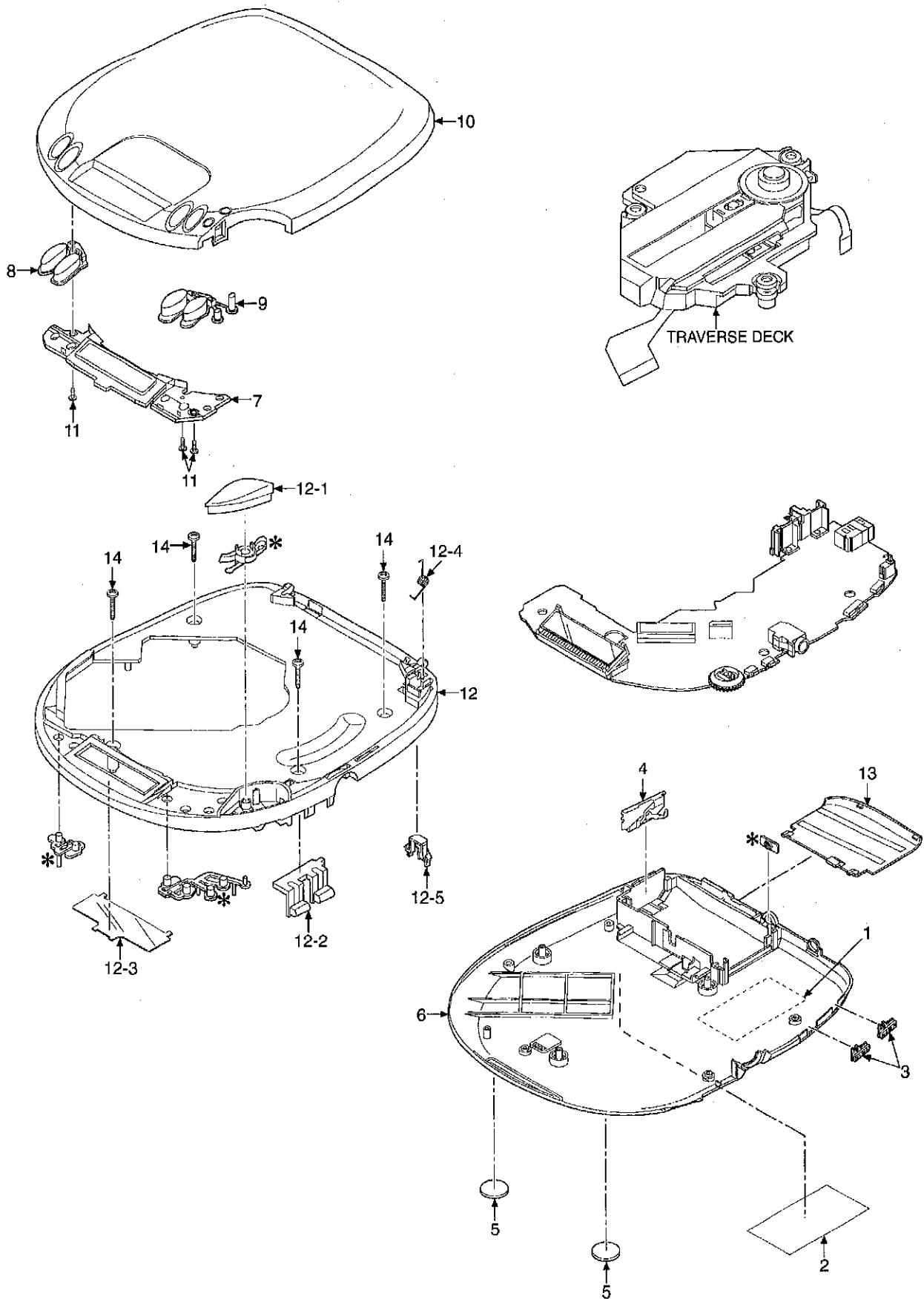

Note : We do not supply those items of parts marked *.

17 Traverse Unit Parts Location

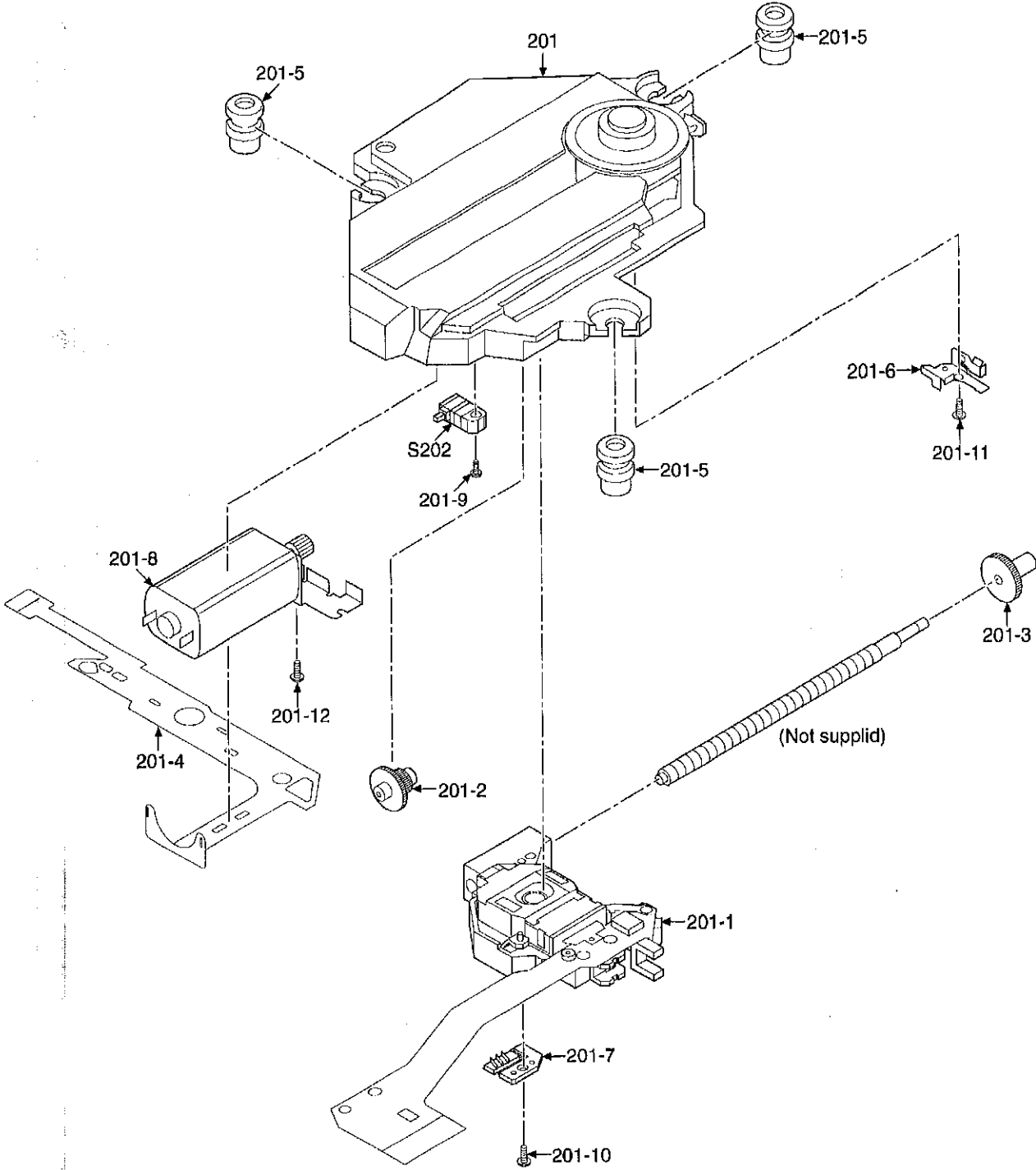

18 Packaging

