

Service Manual

Portable CD Player

SL-S600

COMPACT disc
DIGITAL AUDIO

MASH[®]
multi-stage noise shaping

Colour

(K) . . . Black Type

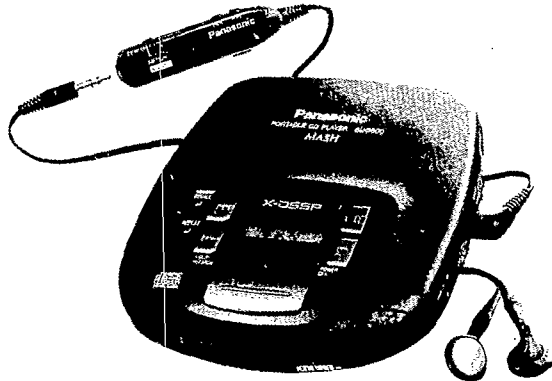

Areas

Suffix for Model No.	Areas	Colour
[GK]	China	(K)
[GH]	Hong Kong	

* MASH is a trademark of NTT.

TRAVERSE DECK: RAE0140Z MECHANISM SERIES

* * * These specifications were measured in the X-DSSP OFF mode.

SPECIFICATIONS

Audio

No. of channels:	2 channels (left and right, stereo)
Output voltage:	0.6 V (50 k Ω) ϕ 3.5 stereo mini jack
Frequency response:	20~20,000 Hz (+0.5 dB, -1.5 dB)
S/N:	more than 96 dB**
Wow and flutter:	Below measurable limit
DA converter:	1 bit, MASH [®]
Headphone output level:	max. 9 mW+9 mW/16 Ω (adjustable) stereo mini jack ϕ 3.5
Digital filter:	8 times over sampling

Signal Format

Correction system:	Technics New Super Decoding Algorithm
--------------------	--

Pickup

Type:	One beam
Light source:	Semiconductor laser
Wavelength:	780 nm
Lens:	Glass pressed lens

Playing time;

[When used in hold mode at 25°C (77°F) temperature and on flat and stable surface.]

Batteries used	X-DSSP OFF/ON
Rechargeable batteries	About 4 hours 30 minutes/ About 3 hours 30 minutes
Panasonic alkaline dry cell batteries	About 18 hours/ About 12 hours

The play time may be less depending on the operating conditions.

Recharging time: About 1 hour 30 minutes

General

Power requirement:

AC; with an included Panasonic AC adaptor
RFEA401E-3S (GK)
RFEA401E-2S (GH)
Batteries; DC 3 V (two "AA" size batteries, not included)
(Panasonic R6P/LR6 or equivalent, not included)
Rechargeable Batteries; DC 2.4 V with an included Panasonic Rechargeable Batteries (RP-BP60SYS2)
Car Battery; with an optional Panasonic car adaptor (SH-CDC9)
DC 4.5 V \diamond \ominus \diamond

DC IN:

Operational temperature range:

0°C-40°C (32°F-104°F)

Rechargeable

temperature range:

5°C-40°C (41°F-104°F)

Power supply:

DC 4.5 V

Power consumption:

Power source	X-DSSP OFF/ON
Using AC adaptor	2.8W/3.0W

When recharging the

batteries:

Approx. 5.1 W

Dimensions (W×H×D):

128.0 × 30.8 × 136.0mm

Weight:

300 g (with batteries)

260 g (without batteries)

Note: Design and specifications are subject to change without notice.

Weight and dimensions are approximate.

Panasonic



Panasonic/Technics

© 1997 Matsushita Electric Industrial Co., Ltd.
All rights reserved. Unauthorized copying and distribution is a violation of law.

⚠ WARNING

This service information is designed for experienced repair technicians only and is not designed for use by the general public. It does not contain warnings or cautions to advise non-technical individuals of potential dangers in attempting to service a product. Products powered by electricity should be serviced or repaired only by experienced professional technicians. Any attempt to service or repair the product or products dealt with in this service information by anyone else could result in serious injury or death.

CONTENTS

Page	Page		
PRECAUTION OF LASER DIODE	2	AUTOMATIC ADJUSTMENT RESULTS	
LOCATION OF CONTROLS	3	DISPLAY FUNCTION (SELF-CHECK FUNCTION)	16, 17
ACCESSORIES	3	BLOCK DIAGRAM	18~21
EXTRA DIGITAL SOUND SHOCK PROTECTOR	4	SCHEMATIC DIAGRAM	22~27
ACCIDENTAL OPERATION PREVENTION FUNCTION	4	PRINTED CIRCUIT BOARD AND	
POWER SUPPLY PREPARATIONS	5	WIRING CONNECTION DIAGRAM	28, 29
USING THE UNIT WITH OPTIONAL ACCESSORIES	6	TERMINAL GUIDE	30~34
HANDLING PRECAUTIONS FOR TRAVERSE DECK	6	REPLACEMENT PARTS LIST	35, 36, 40
OPERATION CHECKS AND MAIN COMPONENT		CABINET PARTS LOCATION	37
REPLACEMENT PROCEDURES	7~13	RESISTORS AND CAPACITORS	38, 39
MEASUREMENTS AND ADJUSTMENTS	13, 14	PACKAGING	40
CHECKING THE OPERATION PROBLEMS ON			
THE TRAVERSE DECK	15		

PRECAUTION OF LASER DIODE

CAUTION: This unit utilizes a class 1 laser. Invisible laser radiation is emitted from the optical pickup lens when the unit is turned on :

1. Do not look directly into the pickup lens.
2. Do not use optical instruments to look at the pickup lens.
3. Do not adjust the preset variable resistor on the optical pickup.
4. Do not disassemble the optical pickup unit.
5. If the optical pickup is replaced, use the manufactures specified replacement pickup only.
6. Use of control or adjustments or performance of procedures other than those specified herin may result in hazardous radiation exposure.

Caution:

This is a laser product.

Improper process of control, adjustment and operation not written in this hand book may cause serious radiation leakage.

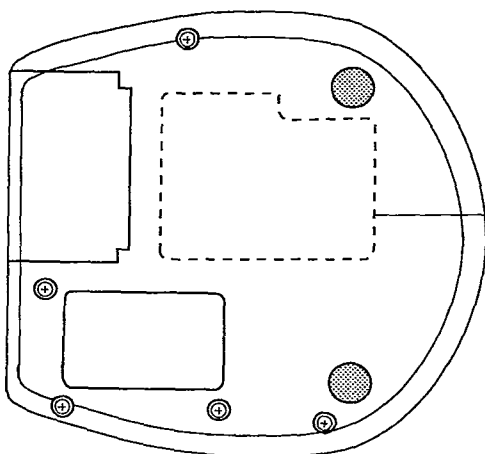

(Bottom Side)

RQLS0077-2

CLASS 1 LASER PRODUCT		VARO! Avattaessa ja suojalukitus ohitettaessa olet alttiina näkymätön lasersäteilylle. Älä katso säteeseen.
ADVARSEL USYNLIG LASERSTRÅLING VED ÅBNING, NÅR SIKKERHEDSÅFBRYDERE ER UDE AF FUNKTION. UNDGÅ UDSÆTTELSE FOR STRÅLING		VARNING! Osynlig laserstråling når denna del är öppnad och spårren är urkopplad. Beträkta ej strålen.
VORSICHT Unsichtbare Laserstrahlung, wenn Abdeckung geöffnet und Sicherheitsverriegelung überbrückt. Nicht dem Strahl aussetzen	DANGER Invisible laser radiation when open and interlock defeated. AVOID DIRECT EXPOSURE TO BEAM	ADVERSEL! Usynlig laserstråling når deksel åpnes og sikkerhetslås brytes. Unngå eksponering for strålen RQLS0077-2

LOCATION OF CONTROLS

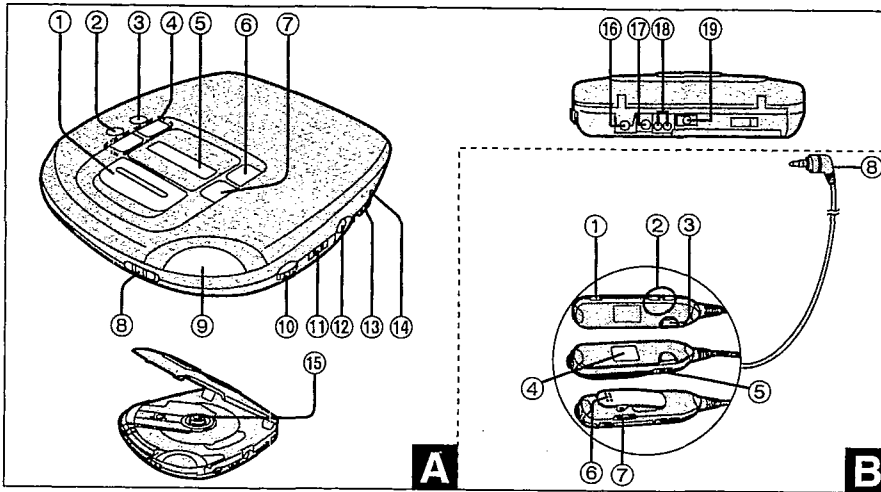

Portable CD player **A**

- ① Hold lock switch (HOLD-LOCK)
- ② Repeat button (REPEAT)
- ③ Memory/recall button (MEMORY/RECALL)
- ④ Skip/search buttons
(◀◀, ▶▶) •SKIP/SEARCH
- ⑤ Display
- ⑥ Play/pause button (▶ ||)
- ⑦ Stop/power off button (■/POWER OFF)
- ⑧ Optical digital out/Extra digital sound shock protector switch (OPT OUT/X-DSSP)
- ⑨ Open button (OPEN)
- ⑩ Headphones volume control (VOLUME)
- ⑪ Train/S-XBS selector (TRAIN, S-XBS, OFF)
- ⑫ Headphones jack (♫) 16 Ω φ 3.5
- ⑬ Play mode selector (MODE)

- ⑭ Optical digital out jack (OPT DIGITAL OUT)
- ⑮ Push button (PUSH)
- ⑯ Out jack (OUT)
- ⑰ DC in jack (DC IN 4.5 V ⚡)
- ⑱ Connection terminal for battery case
- ⑲ Hole for car mounting base/battery case

Wired remote controller **B**

- ① Repeat button (REPEAT)
- ② Skip/search buttons (◀◀, ▶▶)
- ③ Play/stop/off button
- ④ Display
- ⑤ Hold switch (HOLD)
- ⑥ Clip
- ⑦ Volume control (VOL)
- ⑧ Plug

BATTERY SERVICE LIFE

Approx. 4 (Anti-shock memory OFF) hours/3 (Anti-shock memory ON) hours (EIAJ) with rechargeable batteries.

Approx. 17 (Anti-shock memory OFF) hours/11 (Anti-shock memory ON) hours (EIAJ) with Panasonic AM-3/LR6 alkaline (AA-size) batteries.

The above battery service life is measured according to the conditions set forth by EIAJ (Electronic Industries Association of Japan). As the battery service life varies with the method of operation and environmental conditions, use these values as reference.

ACCESSORIES

- AC adaptor
[RFEA401E-3S : (GK)] 1
[RFEA401E-2S : (GH)] 1
- Stereo earphones
(RFEV312P-KS) 1
- Remote control
(RFEV004PCKS) 1
- Soft case
(RFC0041-K) 1

- Battery case
(RFA0627-K) 1
- Rechargeable batteries
(RP-BP60SYS2) 2
- Battery carrying case
(RFKNLS370-K) 1

Remove the rechargeable batteries from their case before use.

EXTRA DIGITAL SOUND SHOCK PROTECTOR

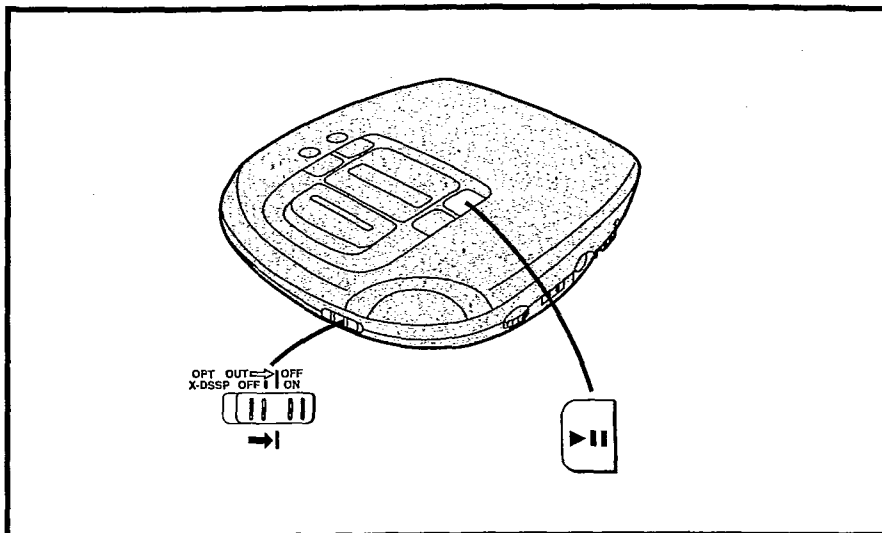

M. RESERVE indicator

M. RESERVE mode	Unit mode	Play mode (play data mode)
	Stable	Sound is heard (sufficient data has been stored).
	Unit sustains a shock.	Sound is heard (stored data is used).
	Shock subsides.	Sound is heard (data storage commences).
	Unit sustains continuous shocks.	Sound is interrupted (no more data is stored).

Listening to sound with the unit connected to an audio system

The X-DSSP function incorporates digital signal compression technology. When listening to sound with the unit connected to a system at home, it is recommended that the X-DSSP selector be set to the OFF position.

Note

When the X-DSSP selector is set ON, the optical digital output jack cannot be used.

ACCIDENTAL OPERATION PREVENTION FUNCTION

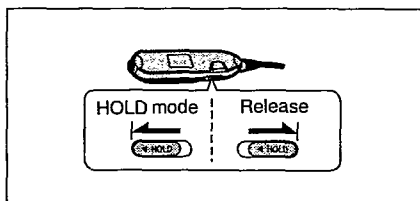
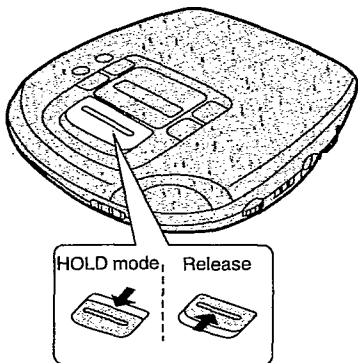

This function prevents the unit from operating even if a control button is pressed in error. (When the unit is in the hold mode, the disc lid can not be opened.)

Use the function to prevent the following situations:

Example 1:

While the unit is not in use, the power is inadvertently turned on and the batteries run down.

Example 2:

Play is interrupted while the unit is in use.

Example 3:

(Available only from the unit)

The disc lid is opened accidentally during play.

This function minimizes sound interruptions due to vibration when listening to a disc while walking about or in a moving vehicle or train.

Once the X-DSSP function has been activated, play data of up to 10 seconds can be stored in the memory.

Therefore, even if the unit sustains an external impact, the data stored in the memory is sent to minimize sound interruptions during play.

1 Set X-DSSP to ON.

2 Press ► II.

The function starts to store the play data, and the M. RESERVE indicator on the display shows how much data is stored.

Notes

- X-DSSP can be set during play but doing so will produce a slight gap in the sound due to a change in the disc speed.
- While the X-DSSP function is on, the life span of the batteries is shortened and sound made by the rotation of the disc increases somewhat because the disc rotates faster and the play data is stored.

To use the accidental operation prevention function

The unit has a HOLD-LOCK switch and the wired remote controller has a HOLD switch, each of which works independently.

[Using the unit]

Set HOLD-LOCK to the HOLD position.

[Using the wired remote controller]

Set HOLD to the HOLD position.

"hold" indicator

If the unit is in the hold mode, the "hold" indicator appears when any of the unit's function buttons is pressed.

When the unit is turned off

The "hold" indicator appears only when ► II is pressed.

Before operating the buttons

Be absolutely sure to move HOLD-LOCK to release the unit from the hold mode.

POWER SUPPLY PREPARATIONS

Refer to the specifications for the duration of the play time provided when rechargeable or dry cell batteries are used.

Using the rechargeable batteries

Make sure that the rechargeable batteries have been recharged before use.

Recharging procedure

- 1 Place the rechargeable batteries inside the unit.
(No batteries other than RP-BP60/SH-CDB8D can be recharged.)

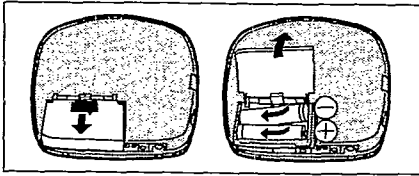

If the battery compartment lid becomes disengaged, position it horizontally and press it back into position.

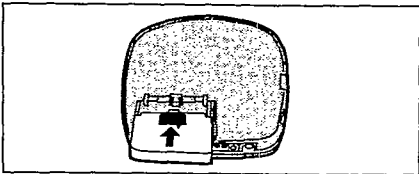

- 2 Connect the AC adaptor.

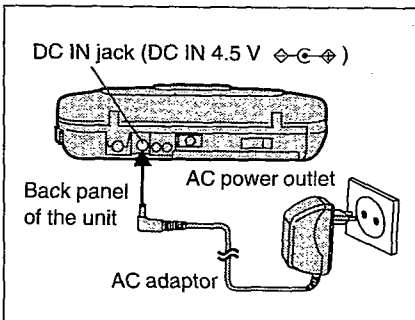

Note

When charging is commenced, the recharging indicator "C" flashes on the display panel. Recharge the batteries fully at which point the recharging indicator will go off.

- 3 Upon completion of the recharging, disconnect the AC adaptor from the DC IN jack and power outlet.

Removing the batteries

Push the batteries upward in the direction of the arrow to remove them.

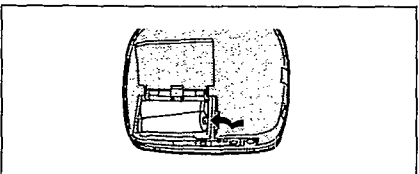

- The batteries can be used for about 10 months (300 times) if they are used every day. They will need to be replaced if the duration of their operation drops drastically.
- Recharging should be performed at 5°C–40°C.
- While recharging, the AC adaptor and rechargeable batteries may get warm. This is normal.

Note

The batteries can be recharged only during off mode (see page 4).

Using dry cell batteries (not included)

Disconnect the AC adaptor and then install two LR6 (UM-3) alkaline batteries.

The batteries are inserted and removed in the same way as for the rechargeable batteries.

To play for even longer durations

Disc play can be enjoyed for an even longer duration by using two additional size LR6 (UM-3) alkaline dry cell batteries.

- 1 Open the battery case lid, and insert the dry cell batteries.
Insert the (–) end first.

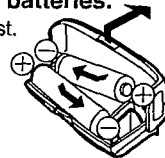

- 2 Attach the battery case to the player.

Align the protrusions on the case with the four cutouts in the player.

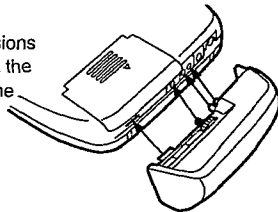

- 3 Lock the case into place using the screw.

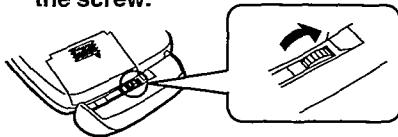

To disengage the case, follow the above procedure in reverse.

Notes

- Do not insert rechargeable batteries in the battery case.
- If rechargeable batteries and dry batteries are to be used at the same time, use fully charged rechargeable batteries and new dry batteries.
- If four dry batteries are to be used, do not use old and new batteries at the same time.

For your reference:

- The player can be powered by the batteries in the battery case alone no batteries need to be loaded in the player.
- The play time differs according to the type of batteries (rechargeable or dry) which are loaded in the player.

If the battery case lid becomes disengaged:

Fit the cutouts on both sides of the battery case lid over the protrusions on the player.

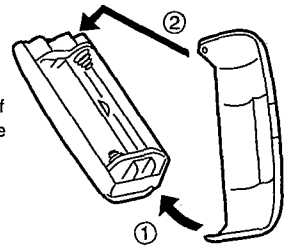

Battery indicator



This starts flashing when the batteries have run down, and after a short while the power is automatically cut off.

(The amount of time during which play continues after the indicator has started flashing differs slightly depending on the type of batteries used.)

Type of battery	Action
Rechargeable batteries	Recharge the batteries again.
Dry cell batteries	Replace with new batteries.

(The battery indicator may not flash if rechargeable batteries, other than those designated by Panasonic, are used.)

Using the AC adaptor

Connect the AC adaptor supplied. Refer to the section on "Using the rechargeable batteries" for details on the connections. (see page 2.)

Using the car adaptor (not included)

Be sure to obtain the car adaptor (SH-CDC9), available as an optional accessory.

The batteries can be recharged inside the car using the car adaptor.

■ USING THE UNIT WITH OPTIONAL ACCESSORIES

Using the unit with an audio system

Using the stereo connection cable (not included), you can hear CDs on your audio system.

- Connect the cable to the amplifier after turning off its power.
- Do not connect the cable to the PHONO jacks on the amplifier.
- Obtain the optional connecting cable if the amplifier comes with mini-phone jacks.
- Adjust the volume level on the amplifier.

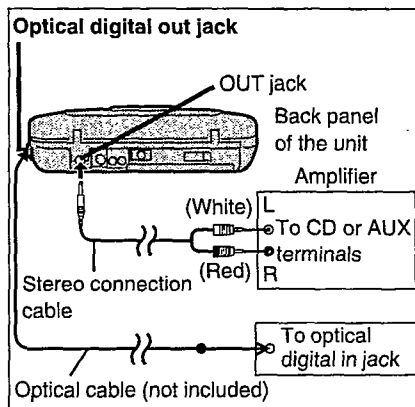

- To use the player with an optical cable, use the AC adaptor and check that the X-DSSP selector is OFF. Operation is not possible when rechargeable batteries or dry cell batteries are used to power the player.

Using the unit with a car audio system stereo

Items to be purchased

For connection to the car audio system:
Car stereo cassette adaptor (SH-CDM9A)

For securing the unit and connecting the power supply:

- Car mounting kit (SH-CDF20)
Car mounting arm, Car mounting base

Note

It may not be possible to use the unit with some types of car stereo owing to restrictions imposed by the construction of the car stereo cassette adaptor.

For further details, refer to the instructions of the part concerned.

■ HANDLING PRECAUTIONS FOR TRAVERSE DECK

The laser diode in the traverse deck (optical pickup) may break down due to potential difference caused by static electricity of clothes or human body.

So, be careful of electrostatic breakdown during repair of the traverse deck (optical pickup).

• Handling of traverse deck (optical pickup)

1. Do not subject the traverse deck (optical pickup) to static electricity as it is extremely sensitive to electrical shock.
2. The short land between the No. ⑬ (LD) and No. ⑫ (GND) pins on the flexible board (FFC) is shorted with a solder build-up to prevent damage to the laser diode. To connect to the PC board, be sure to open by removing the solder build-up, and finish the work quickly.
3. Take care not to apply excessive stress to the flexible board (FFC).
4. Do not turn the variable resistor (laser power adjustment). It has already been adjusted.

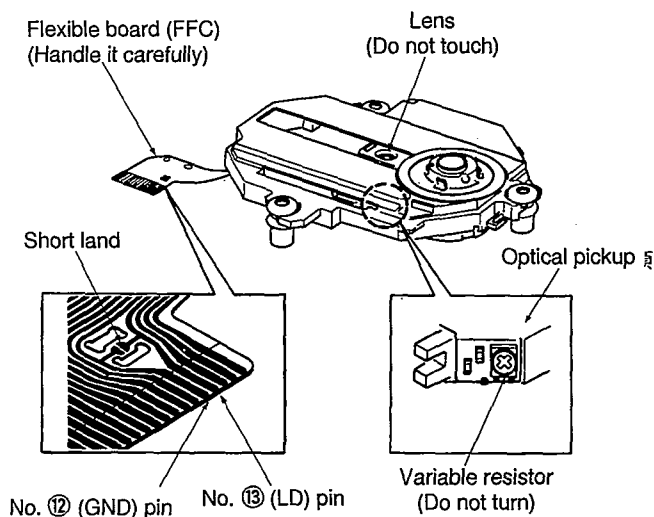

• Grounding for electrostatic breakdown prevention

1. Human body grounding
Use the anti-static wrist strap to discharge the static electricity from your body.
2. Work table grounding
Put a conductive material (sheet) or steel sheet on the area where the optical pickup is placed, and ground the sheet.

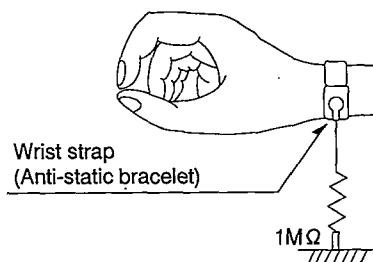

Caution:

The static electricity of your clothes will not be grounded through the wrist strap. So, take care not to let your clothes touch the traverse deck (optical pickup).

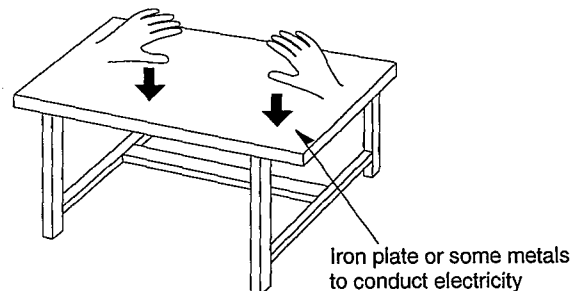

OPERATION CHECKS AND MAIN COMPONENT REPLACEMENT PROCEDURES

Warning: This product uses a laser diode. Refer to caution statements on page 2.

- NOTE**
1. This section describes procedures for checking the operation of the major printed circuit boards and replacing the main components.
 2. For reassembly after operation checks or replacement, reverse the respective procedures. Special reassembly procedures are described only when required.
 3. Illustrated screws are equivalent to actual size.
 4. [] indicates parts No.

1. Checking for the main P.C.B.



[XTN17+6GFZ]

Step 3

Move the intermediate cabinet ass'y in the direction of arrow.

Step 2

Pressing the OPEN button, open the CD cover ass'y.

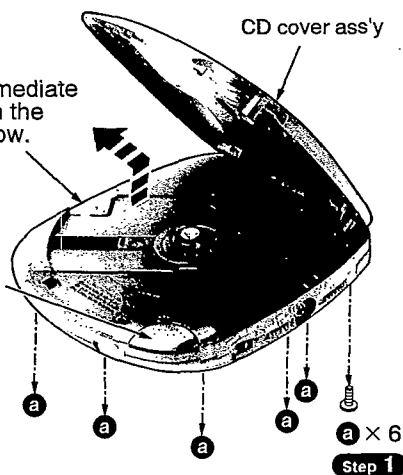

NOTE

- After checking, unsolder the short land to open circuit.
- The tip of screw must not protrude above the floating rubber. (The protruded screw may be damaged the test disc.)
- When the screw head sits on the P.C.B., insulate them with insulation material or etc.

Nut 3mm [XNG3ES]

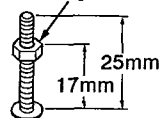

Screw 3mm x 25mm [XSN3+25S]

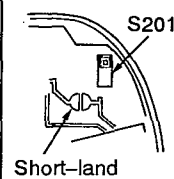
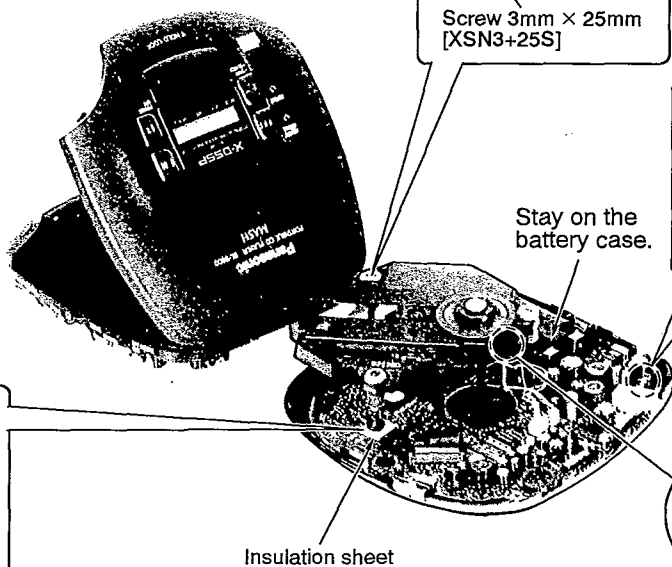

Step 6

Short-circuit the land by soldering.

Nut 3mm [XNG3ES]

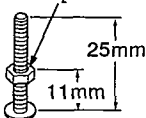

Screw 3mm x 25mm [XSN3+25S]

Step 5

Sustain the traverse deck with the floating rubber inserted screws and nuts as shown above.

Step 4

Remove the lead wires from the clasper.

• Check the main P.C.B. (Component side as shown below. [Right side of P.C.B..])

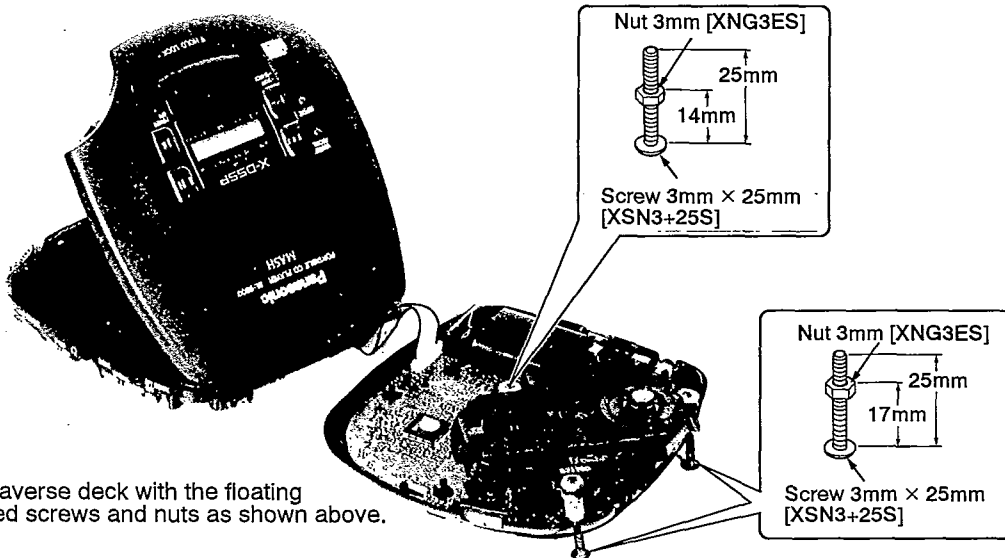
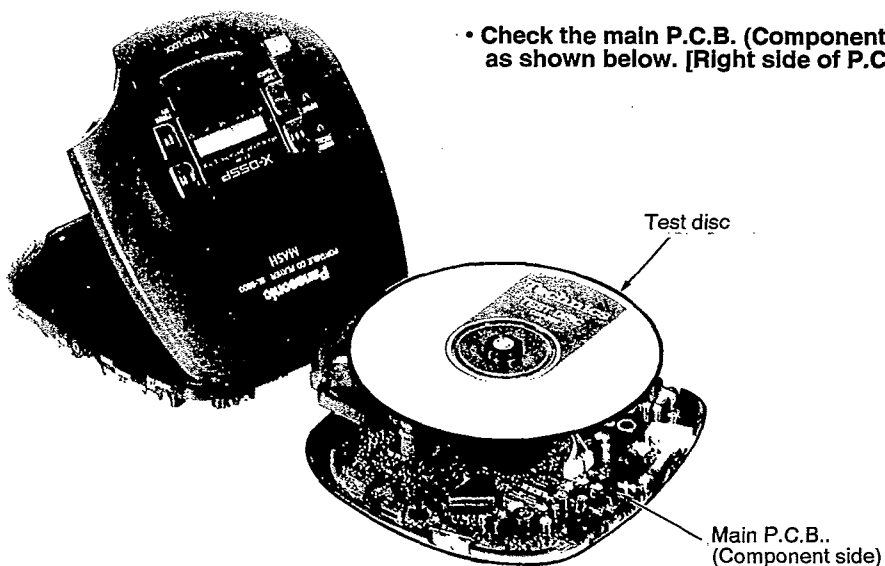

Step 7

Sustain the traverse deck with the floating rubber inserted screws and nuts as shown above.

• Check the main P.C.B. (Component side as shown below. [Left side of P.C.B..])

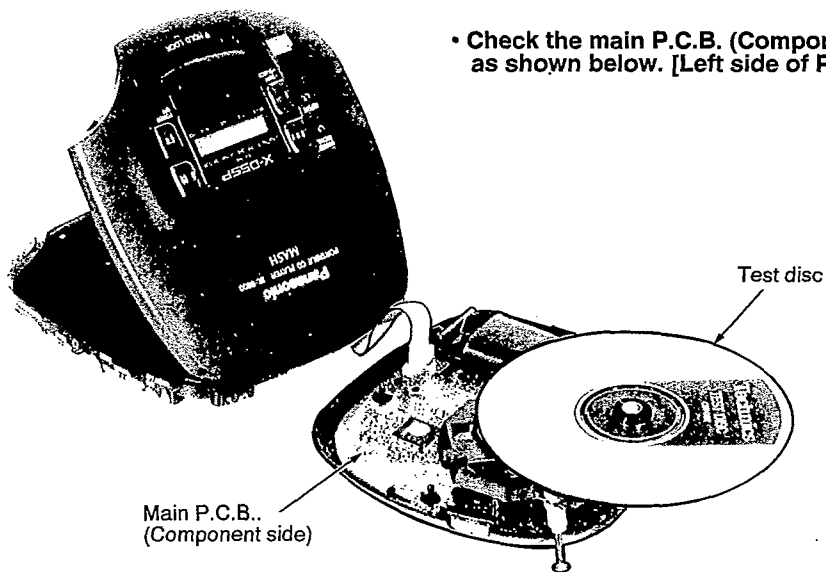

• Checking for the P.C.B. (Solder side).



[XTN17+6GFZ]

Step 3

Move the intermediate cabinet ass'y in the direction of arrow.

Step 2

Pressing the OPEN button, open the CD cover ass'y.

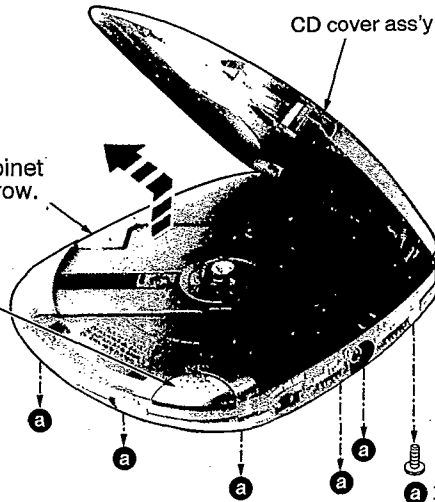

Step 1



Step 5

Remove the traverse deck and main P.C.B..

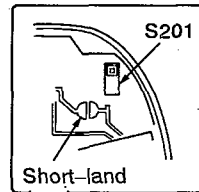

Step 6

Short-circuit the land by soldering.

Step 4

Remove the switch knobs.

Switch knob

Switch knobs

Step 7

Align the floating rubber with the boss.

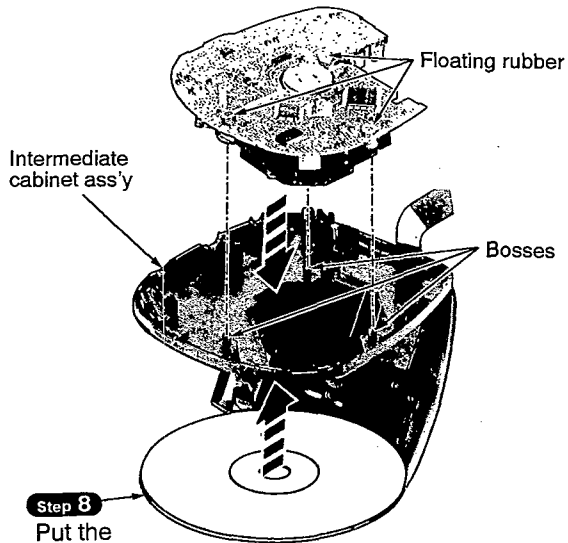

Step 8

Put the test disc.

• Check the main P.C.B. (Solder side) as shown below.

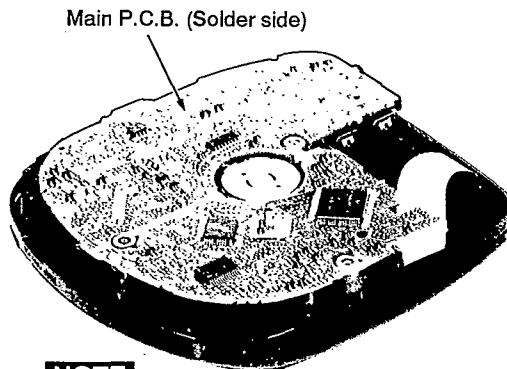

NOTE

After checking, unsolder the short land to open circuit.

Notice for installation of switch knobs

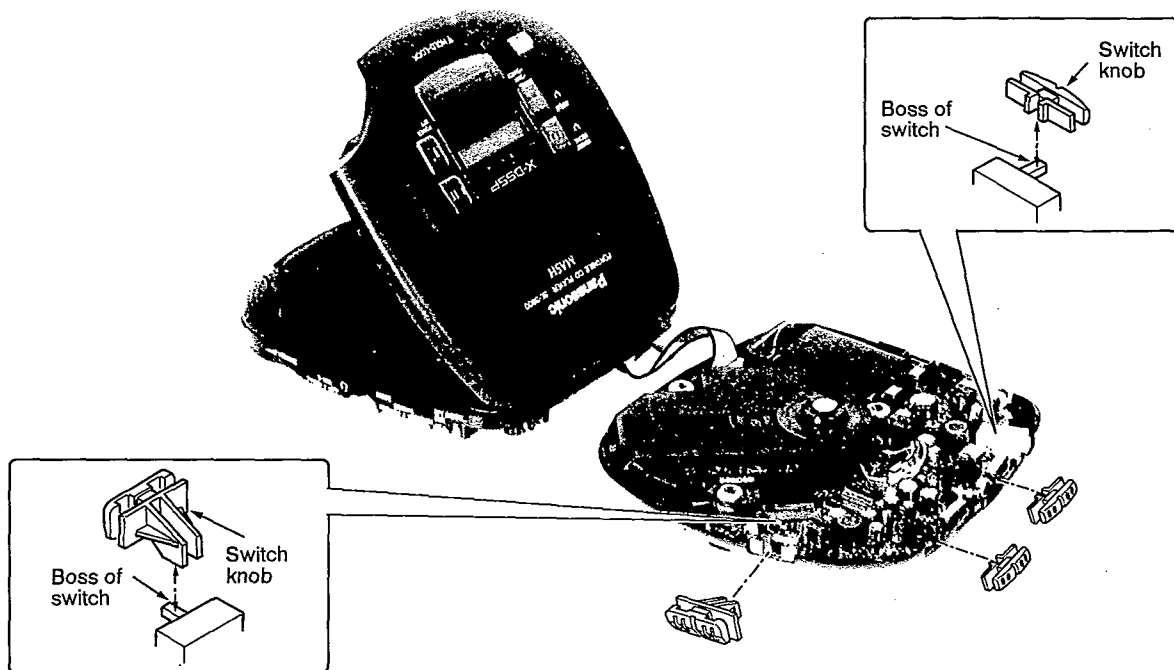

• Make sure the bosses of switch are fit in the knobs of switch.

2. 更換橫向機構

• Follow the **Step 1** ~ **Step 3** in item 1.

NOTE

Short-circuit the land between the pin ④ (LD) and pin ⑤ (GND) of optical pickup FFC. (Refer to "handling precautions for traverse deck" on page 10).

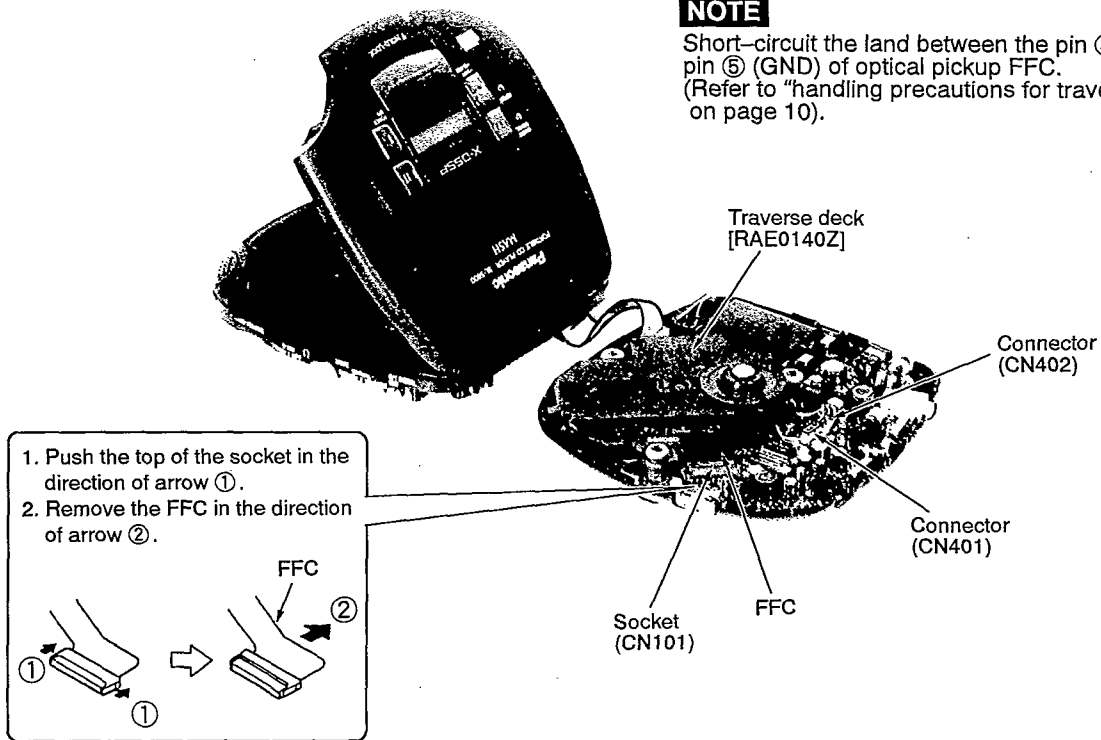

3. Replacement for the LCD and CD cover

• Follow the **Step 1** ~ **Step 3** in item 1.

Step 1 Remove the FFC.

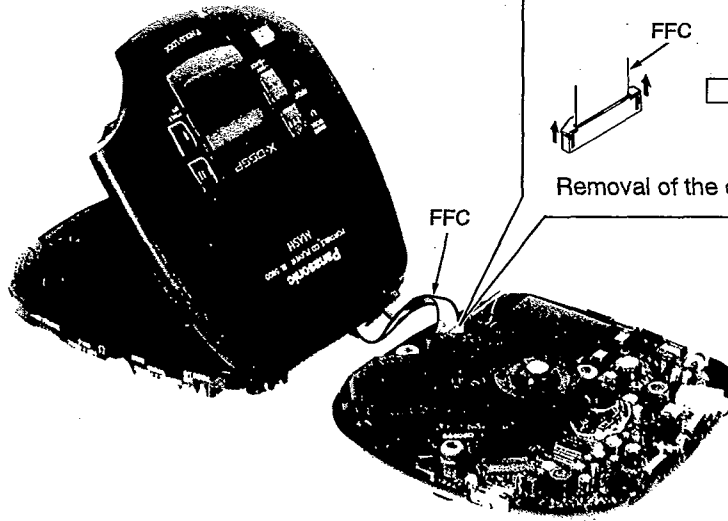
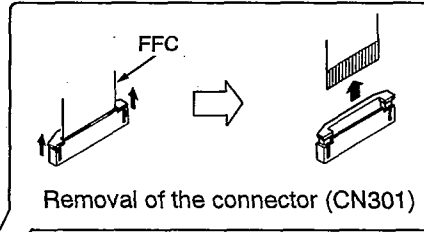

Step 2
Close the CD cover ass'y.

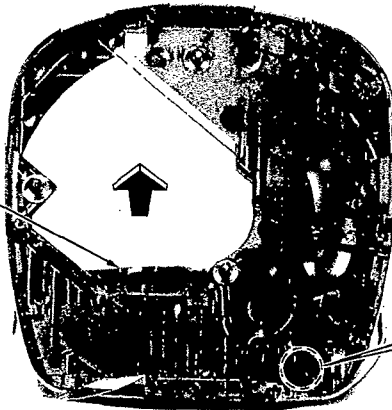

Step 3
Release the claw, and then remove the shaft.

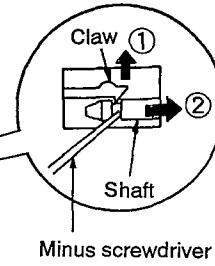

CD cover ass'y

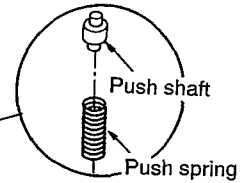
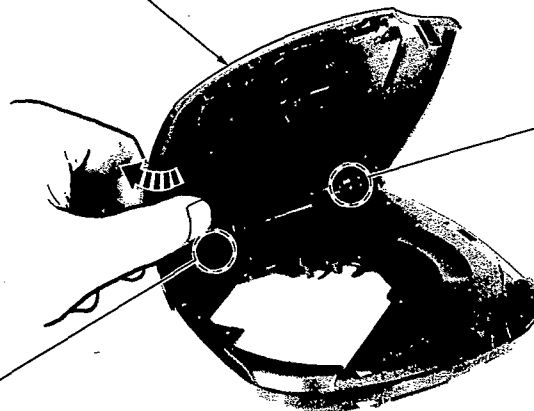

Step 5
Remove the CD cover ass'y from rib.

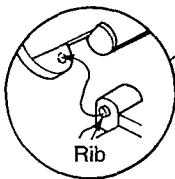

Step 4
Pressing the OPEN button, open the CD cover ass'y.

NOTE

When the CD cover ass'y is removed, the push shaft and the push spring will also be removed. Be careful not to loose them.

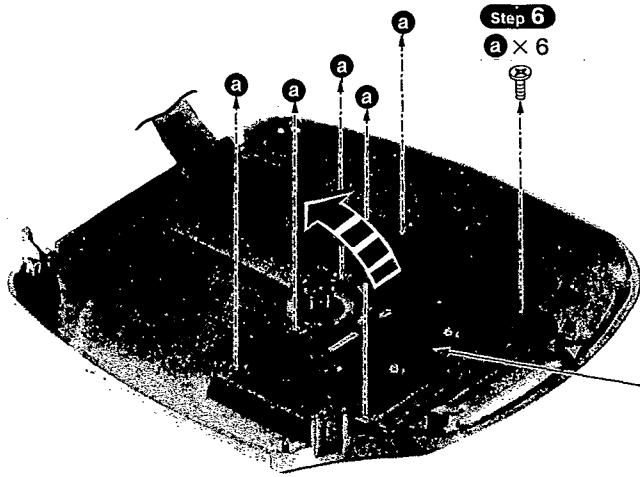

- a, c
- [RHE5119YA]
- b
- [RHE5155YA]

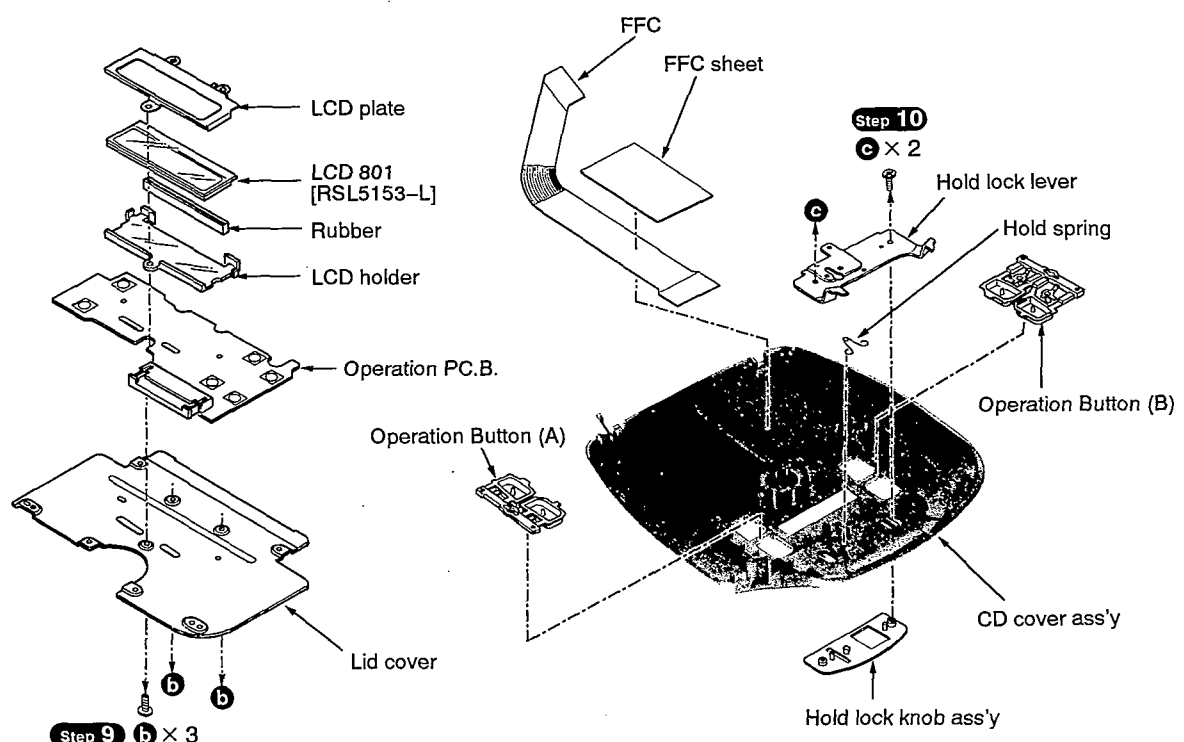
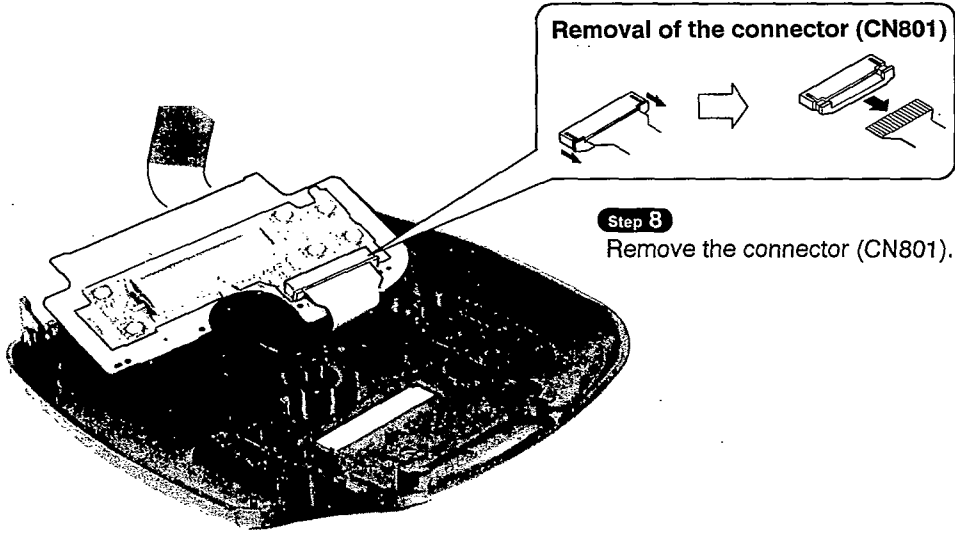

Reassembly procedures of CD cover ass'y

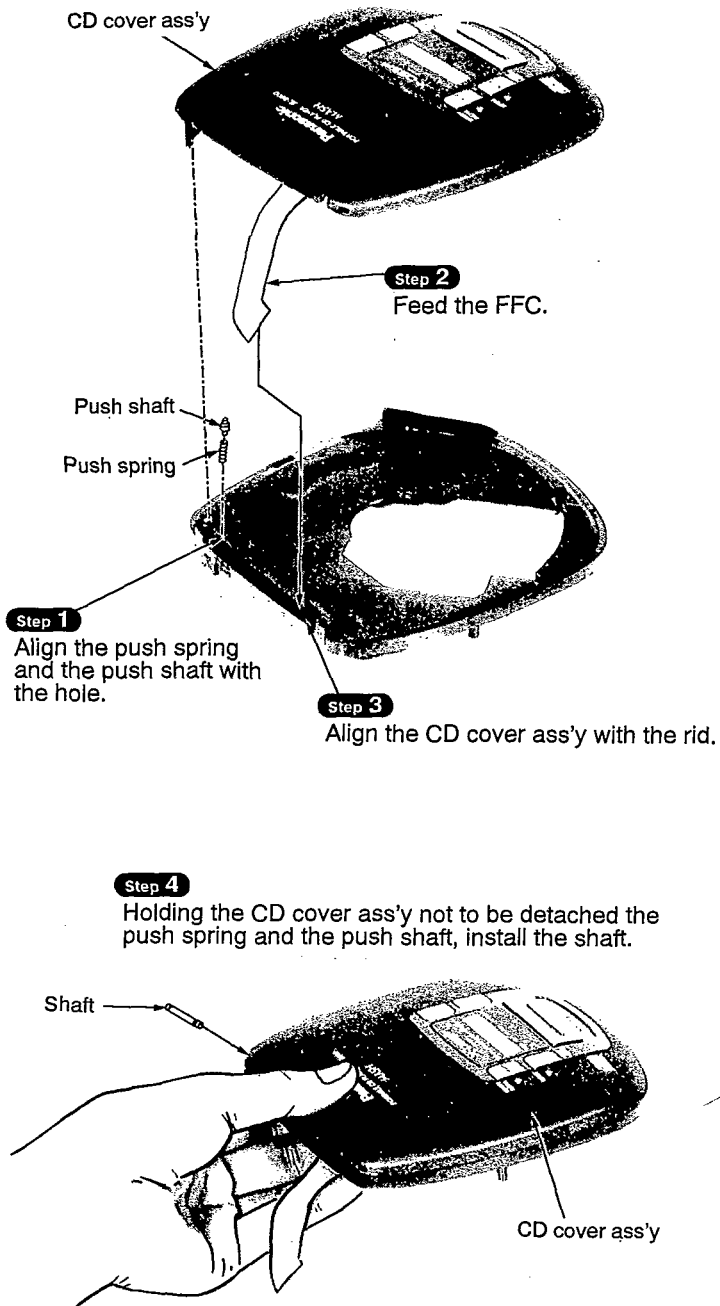

MEASUREMENTS AND ADJUSTMENTS

Warning: This product uses a laser diode. Refer to caution statements on page 2.

Measuring instruments and special tools

Test discs

1. Playability test disc (SZZP1054C)
2. Uneven test disc (SZZP1056C)

- Musical program disc (ordinary)
- DC voltmeter
- Lead wire (for test points)

Test short land

Short-circuit the lands of the laser ON/OFF switch (S201) by soldering them. It turns "ON" position. (Refer to below figure or printed circuit board and wiring connection diagram for short land location on pages 28, 29.)

Note: Remove the solders from the lands after adjustment.

● Adjustment point

- Notes: 1. Please refer to the printed circuit board and wiring connection diagram for test point locations.
2. Take care to connect CN101.

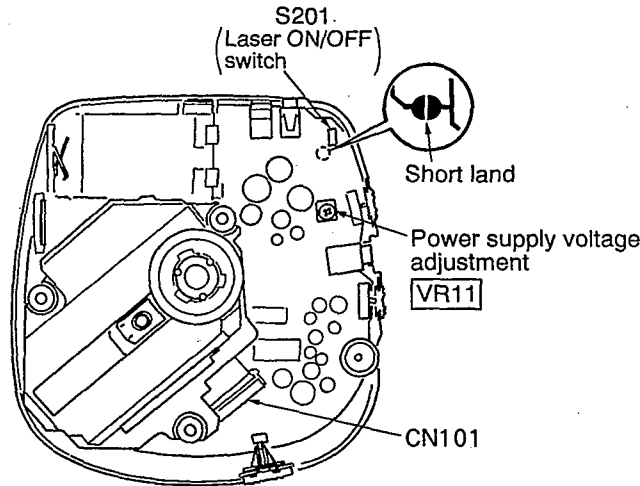

● Adjustment procedure

(1) POWER SUPPLY VOLTAGE ADJUSTMENT

1. Connect the DC voltmeter to **TP103** (VCC) (+) and **TP104** (GND) on the P.C.B.
2. Connect the AC adaptor cord to the DC (IN) port and move the PLAY switch to the ON position. (Use a new dry cell battery or a rechargeable battery that is full charged.)
3. Insert the test disc, and switch the player power ON.
4. Adjust VR11 on the P.C.B. at 3.35 ± 0.05 V.

(2) CHECK OF PLAY OPERATION

*** Checking Skip Search**

1. Play an ordinary musical program disc.
2. Press the skip button to check for normal skip search operation (in both the forward and backward directions).

*** Checking Manual Search**

1. Play an ordinary musical program disc.
2. Press the manual search button to check for smooth manual search operations at either low or high speed (in both the forward and backward directions).

*** Checking Playability**

1. Play the 0.7 mm black dot and the 0.7 mm wedge on the playability test disc (SZZP1054C) and verify that no sound skip or noise occurs.
2. Play the middle tracks of the uneven test disc (SZZP1056C) and verify that no sound skip or noise occurs.

● Automatic adjustment

On our conventional type portable CD player, there were mounted 6 semi-fixed controls for each adjustment. Since the SL-S600 servo circuit is equipped with an automatic adjusting circuit, these controls are removed from SL-S600.

On conventional portable CD player
Use for Old Servo IC (AN8373SE2, AN8374SE2)

1. Tracking Offset Adjustment VR (TOC)
2. Focus Offset Adjustment VR (FOC)
3. Tracking Gain Adjustment VR (TGC)
4. Focus Gain Adjustment VR (FGC)
5. Tracking Balance Adjustment VR (TBC)
6. Focus Balance Adjustment VR (FBC)

On SL-S600
Use for New Servo IC (AN8834SBE1, MN662745RPC)

- ➔ Non Adjustment
- ➔ Automatic Adjusting Circuit

Total 6 Adjustment VRs ➔ No Adjustment VR

Although all discs are manufactured according to the same specifications, their characteristics are not always precisely the same because they are produced by different manufacturers in various lots, or have different warp etc. SL-S600 automatically controls the servo circuit to obtain optimum performance according to any disc's characteristics. Therefore, no malfunction occurs because of mis-adjustment.

CHECKING THE OPERATION PROBLEMS ON THE TRAVERSE DECK (OPTICAL PICKUP)

Make sure to follow the procedures below to check the operation problems of the traverse deck (optical pickup) before replacing it. Replace the traverse deck only after the problem is identified.

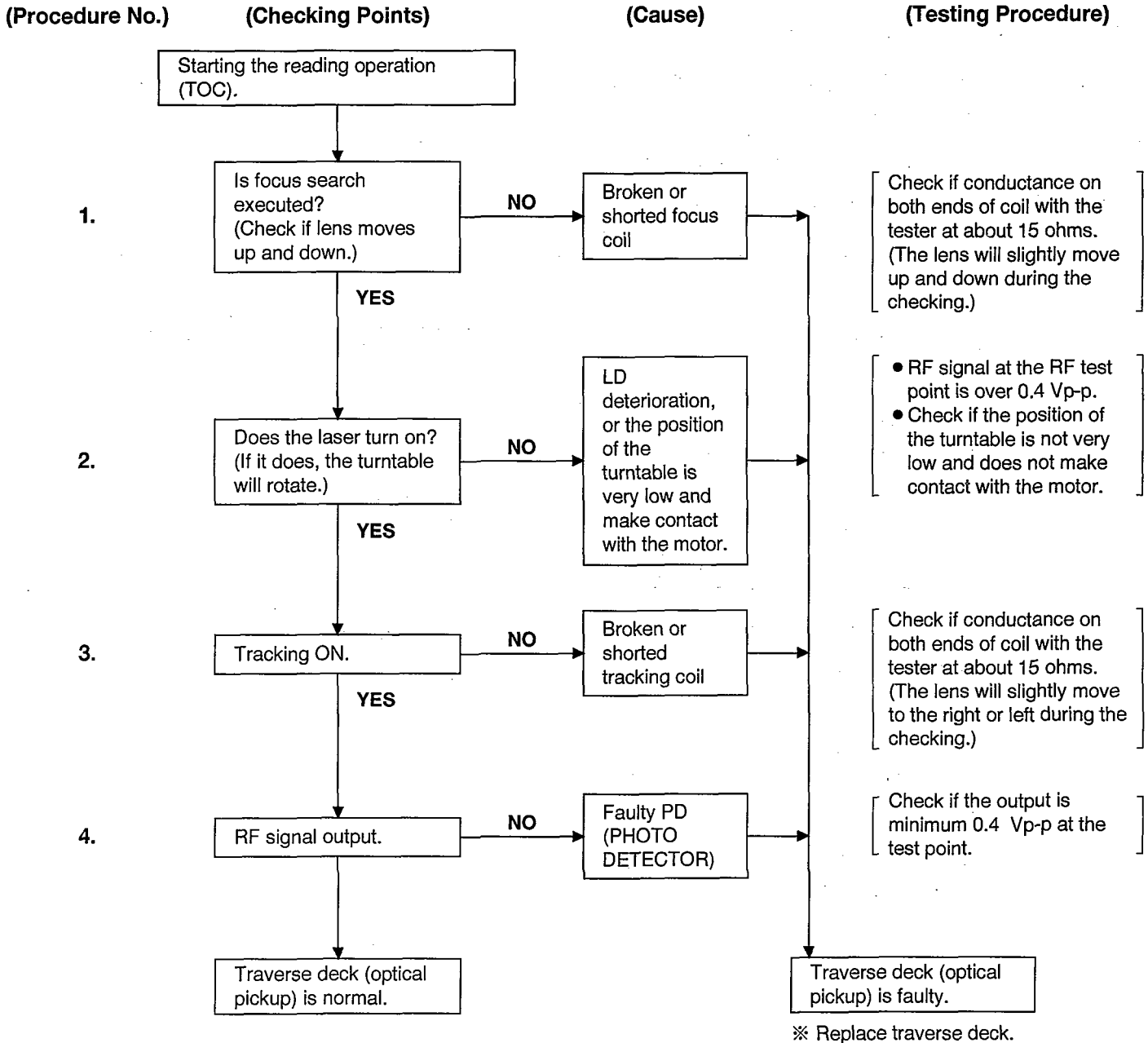

- Check electrical circuit.
- Check for flaws on disc or if it is warped or not centered.

• Check the operations described below on the traverse deck after replacing it.

* Checking Skip Search

1. Play an ordinary musical program disc.
2. Press the skip button to check for normal skip search operation (in both the forward and reverse directions).

* Checking Manual Search

1. Play an ordinary musical program disc.
2. Press the manual search button to check for smooth manual search operations at either low or high speed (in both the forward and reverse directions).

* Checking Playability

1. Play the 0.7 mm black dot and the 0.7 mm wedge on the playability test disc (SZZP1054C) and verify that no sound skip or noise occurs.
2. Play the middle tracks of the uneven test disc (SZZP1056C) and verify that no sound skip or noise occurs.

■ AUTOMATIC ADJUSTMENT RESULTS DISPLAY FUNCTION (SELF-CHECK FUNCTION)

On this unit (SL-S401C), each automatic adjustment result are displayed on the LCD. This function is convenient to check or identify which automatic adjustment circuit is incorrect. The followings are the contents of the automatic adjustment result displays (self-check function).

● How to display automatic adjustment results

1. Load the test disc (SZZP1054C).
2. Press the ◀◀ (SKIP/SEARCH) and ▶▶ (SKIP/SEARCH) Buttons simultaneously and hold them, and additionally press the ▶ / || (PLAY/PAUSE) Button.
3. Press the ■ (STOP/POWER OFF) Button once.
4. An automatic adjustment result is displayed on the LCD.

● Display of automatic adjustment results (self-check function)

LCD Display

4 bits (TGC, FGC, TBC, FBC) are displayed in hexadecimal system from 0~F.

(Example)

	MSB			LSB	
	TGC	FGC	TBC	FBC	
1)	0	0	0	0	⇒ "E-0" is displayed. (All adjustments are OK.) Normal
2)	0	0	0	1	⇒ "E-1" is displayed. (OK) (OK) (OK) (NG) (Focus balance adjustment is NG (incorrect.))
3)	0	1	0	0	⇒ "E-4" is displayed. (OK) (NG) (OK) (OK) (Focus gain adjustment is NG.)
4)	1	1	1	1	⇒ "E-F" is displayed. (All adjustments are NG.)
5)	1	0	0	0	⇒ "E-8" is displayed. (NG) (OK) (OK) (OK) (Tracking gain adjustment is NG.)

(Each bit ... TGC, FGC, TBC, FBC)
0 ... OK
1 ... NG

Note: If any other disc than the test disc (SZZP1054C) is used, an "E-8" may be displayed.

<Example> Follow the below steps when "E-1" is displayed.

(Cause: Focus balance (FBC) is set beyond the limit.)

• Check if

- (1) the waveform or voltage of the focus servo circuit is correct, and
- (2) the optical pickup returns to the normal state by exchanging the traverse deck.

Follow the below steps when "E-4" is displayed.

(Cause: Focus gain (FGC) is set beyond the limit.)

• Check if

- (1) the waveform or voltage of the focus servo circuit is correct,
- (2) the focus coil of the optical pickup is correct (around 15 ohms), and
- (3) the optical pickup returns to the normal state by exchanging the traverse deck.

Follow the below steps when "E-F" is displayed.

(Cause : All adjustments (TGC, FGC, TBC, FBC) are set beyond the limit.)

• Check if

- (1) the optical pickup returns to the normal state by exchanging the traverse deck, and
- (2) the waveform or voltage of the servo IC's (IC101, 501) are correct.

Note:

It is not always necessary to exchange the traverse deck when an error message is displayed.

Be sure to check if the circuit is defective or not before exchanging the traverse deck.

Note:

If any other disc than the test disc (SZZP1054C) is used, an error message may be displayed. This is not a malfunction.

BLOCK DIAGRAM

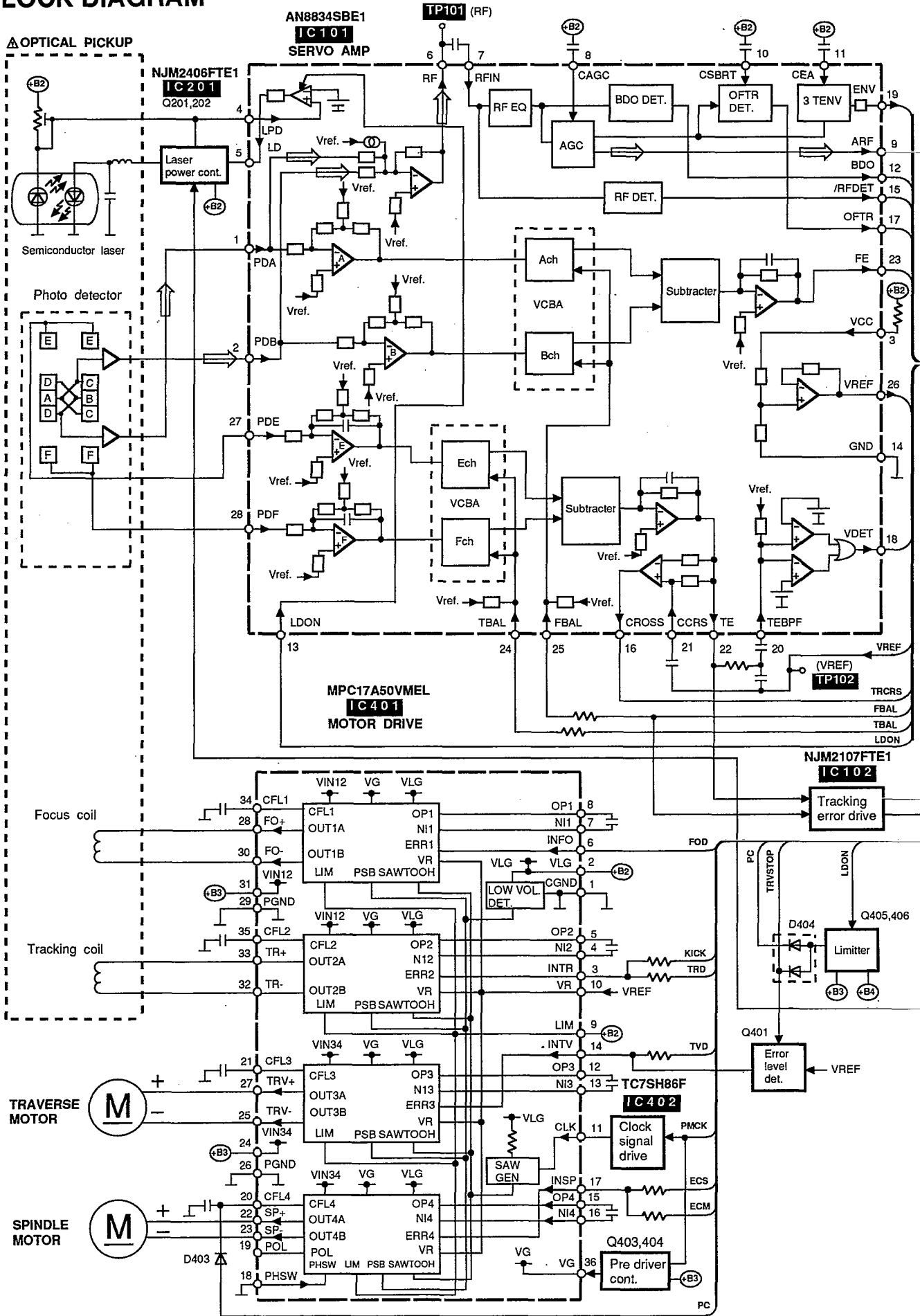

● Signal line ➡ : Audio signal

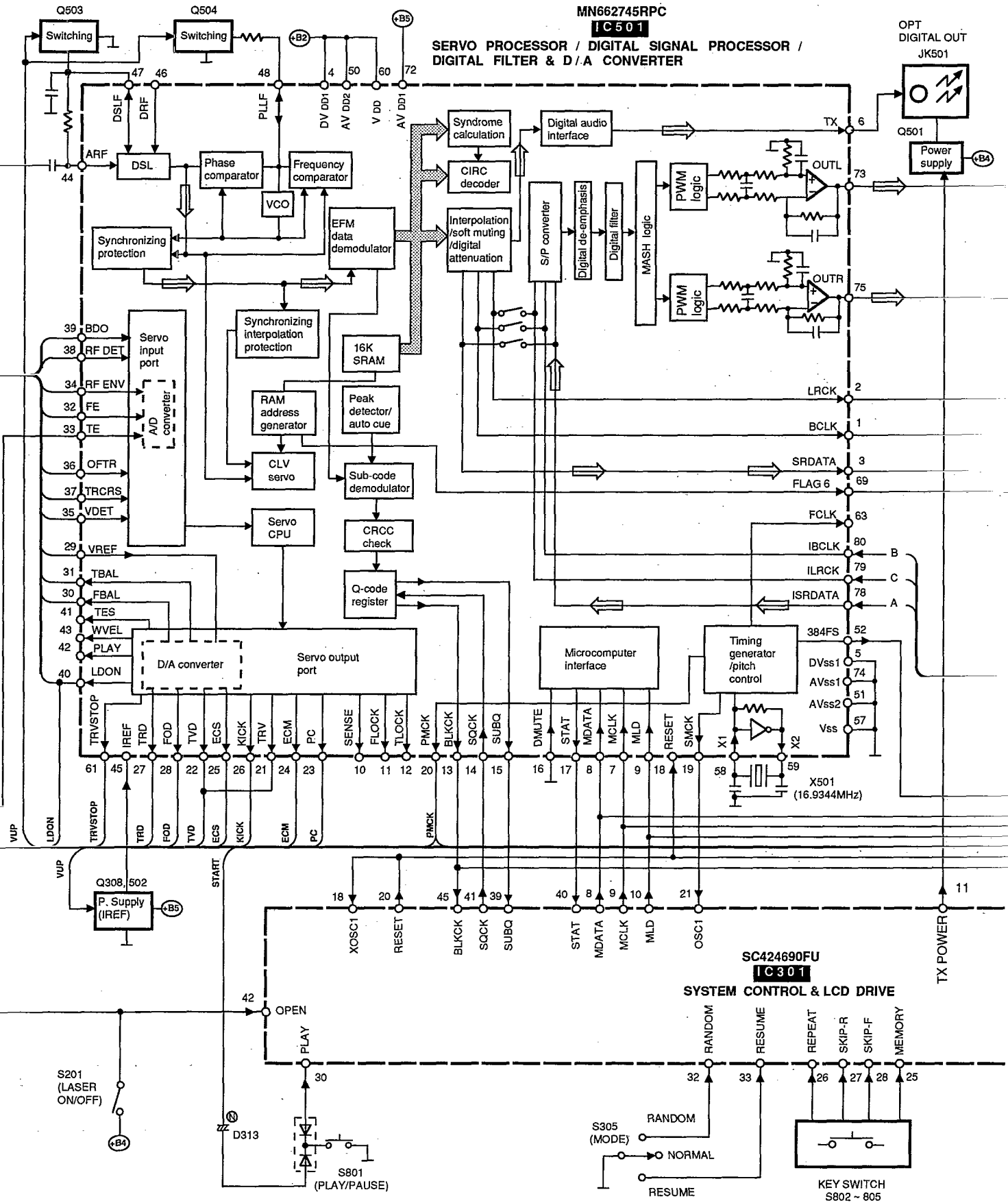

● Signal line ⇨ : Audio signal

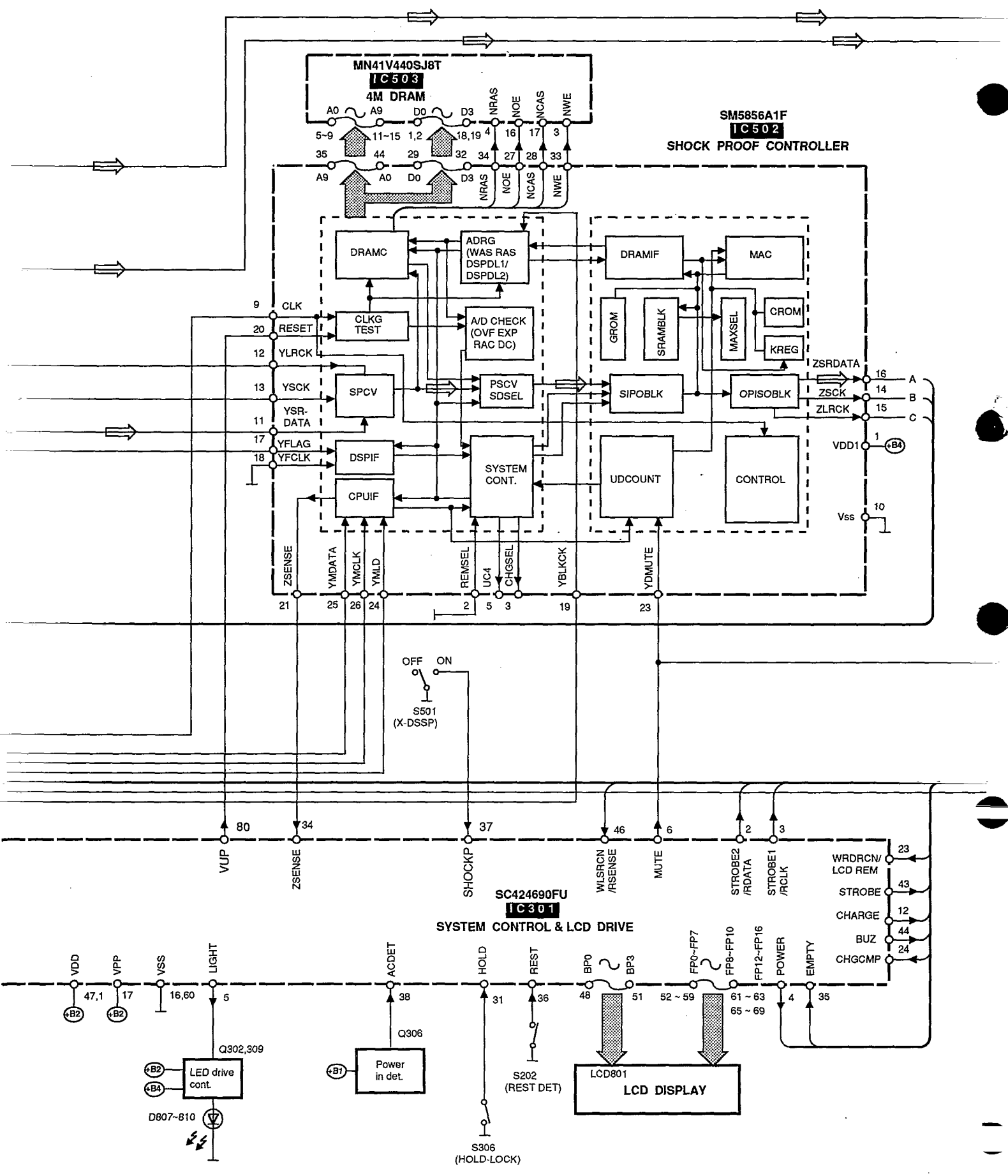

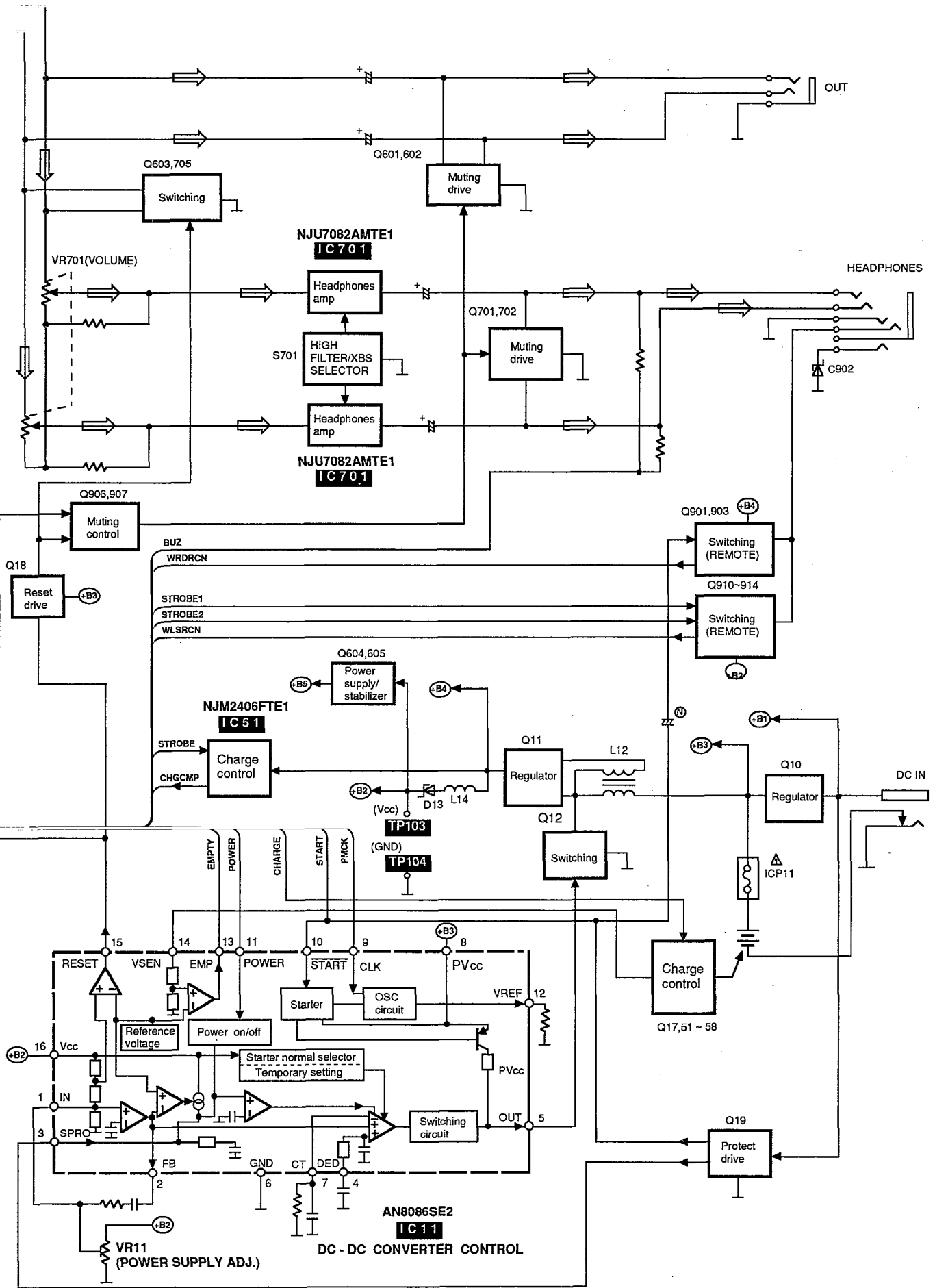

SCHEMATIC DIAGRAM (Parts list on pages 39, 40, 42, 43.)

(This schematic diagram may be modified at any time with the development of new technology.)

Notes:

- **S201:** Laser ON/OFF switch in "OFF" position.
(It turns "ON" with disc holder closed.)
- **S202:** Rest detector in "OFF" position.
(It turns "ON" when optical pickup comes to innermost periphery.)
- **S305:** Play mode selector (MODE) switch in "RANDOM" position.
(RANDOM↔NORMAL↔RESUME)
- **S306:** Hold lock (HOLD-LOCK) switch in "OFF" position.
- **S501:** Extra anti-shock (EXTRA ANTI-SHOCK) switch.
- **S701:** High filter/XBS selector (HIGH FILTER, XBS, OFF) switch in "OFF" position.
- **S801:** Play/pause (▶ ||) switch.
- **S802, 803:** Skip/search (◀◀-SKIP/-SEARCH▶▶) switches.
(S802: ◀◀, S803 : ▶▶)
- **S804:** Repeat (REPEAT) switch.
- **S805:** Memory/recall (MEMORY/RECALL) switch.
- **S806:** Stop/power off (■ /POWER OFF) switch.
- The voltage value and waveforms are the reference voltage of this measured by DC electronic voltmeter (high impedance) and oscilloscope on the basis of GND terminal (DC IN Jack). Accordingly, there may arise some errors in the voltage values and waveforms depending upon the internal impedance of the tester or measuring unit.

*The parenthesized is the voltage for test disc (1 kHz, L+R, 0 dB) in play mode, and the other, for no disc in stop mode.

* AC adaptor is used for power supply.

- : Positive voltage lines.
- : Audio signal lines.

Important safety notice:







Components identified by Δ mark have special characteristics important for safety. Furthermore, special parts which have purposes of fire-retardant (resistors), high-quality sound (capacitors), low-noise (resistors), etc. are used. When replacing any of components, be sure to use only manufacture's specified parts shown in the parts list.

Caution!

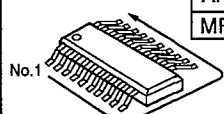
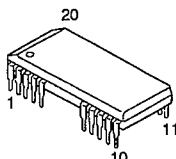
IC and LSI are sensitive to static electricity. Secondary trouble can be prevented by taking care during repair.

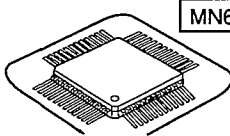
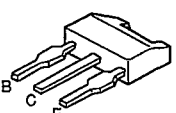
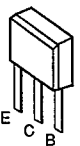
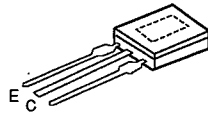
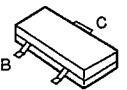
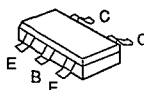
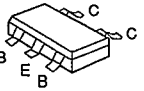
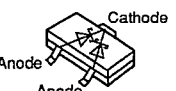
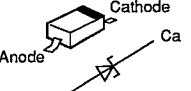
- Cover the parts boxes made of plastics with aluminum foil.
- Ground the soldering iron.
- Put a conductive mat on the work table.
- Do not touch the pins of IC or LSI with fingers directly.

Terminal guide of IC's, transistors and diodes

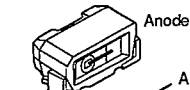
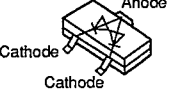
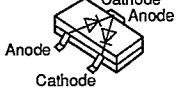
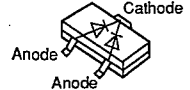
<table border="1"> <tr><td>NJU7082AMTE1</td><td>8PIN</td></tr> <tr><td>AN8086SE2</td><td>16PIN</td></tr> <tr><td>AN8834SBE1</td><td>28PIN</td></tr> <tr><td>MPC17A50VMEL</td><td>36PIN</td></tr> </table> 		NJU7082AMTE1	8PIN	AN8086SE2	16PIN	AN8834SBE1	28PIN	MPC17A50VMEL	36PIN	MN41V440SJ8T 	NJM2107FTE1 NJM2406FTE1 TC7SH86F 	<table border="1"> <tr><td>SM5856A1F</td><td>44PIN</td></tr> <tr><td>SC424690FU</td><td>80PIN</td></tr> <tr><td>MN662745RPC</td><td>80PIN</td></tr> </table> 		SM5856A1F	44PIN	SC424690FU	80PIN	MN662745RPC	80PIN
NJU7082AMTE1	8PIN																		
AN8086SE2	16PIN																		
AN8834SBE1	28PIN																		
MPC17A50VMEL	36PIN																		
SM5856A1F	44PIN																		
SC424690FU	80PIN																		
MN662745RPC	80PIN																		
2SD2074HWSTT 	2SD1450STTA 	2SD2005PQRTA 	2SB709QRSTX UN5115TX 2SB970RSTX UN5210TX 2SB1218QRSTX UN5211TX 2SD601QRSTX UN5213TX 2SD1328RSTTX UN5215 TX 2SD1819QRSTX UN5113TX UN5114TX 	FMS2AT148 															
FMG2T148 FMG4T148 FMG6T148 FMG8T99 FMW1T98 	RB411DT147 	MA8051MTX 	MA8082MTX 	MA110TX 															
MA8033LTX 	LNJ310M6URA 	MA142WATX 	MA143TX 	MA141WKTX 															

A OPERATION CIRCUIT (P.C.Board: on page 28)

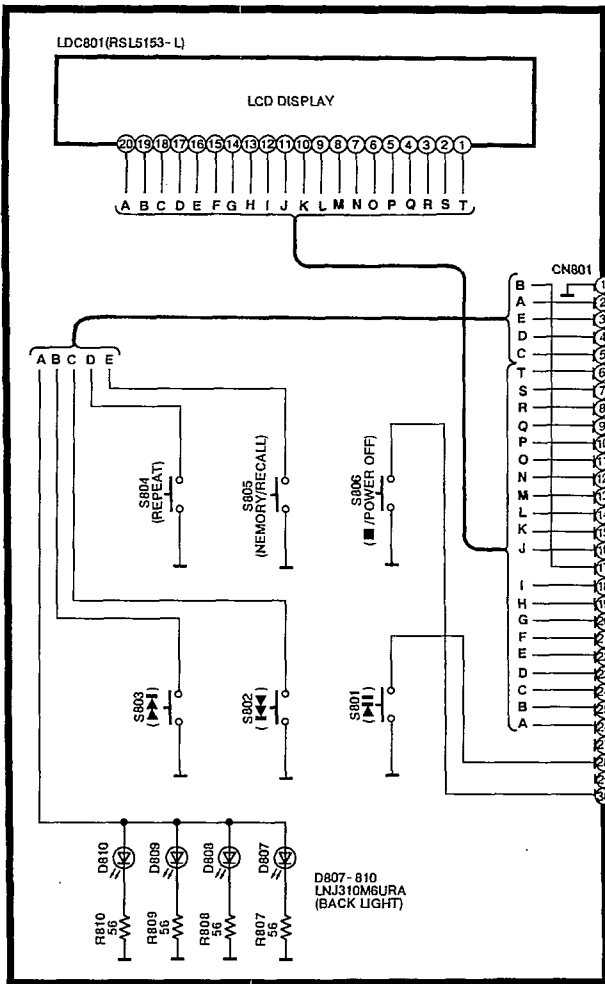

B MAIN CIRCUIT (P.C.Board: on pages 28,29)

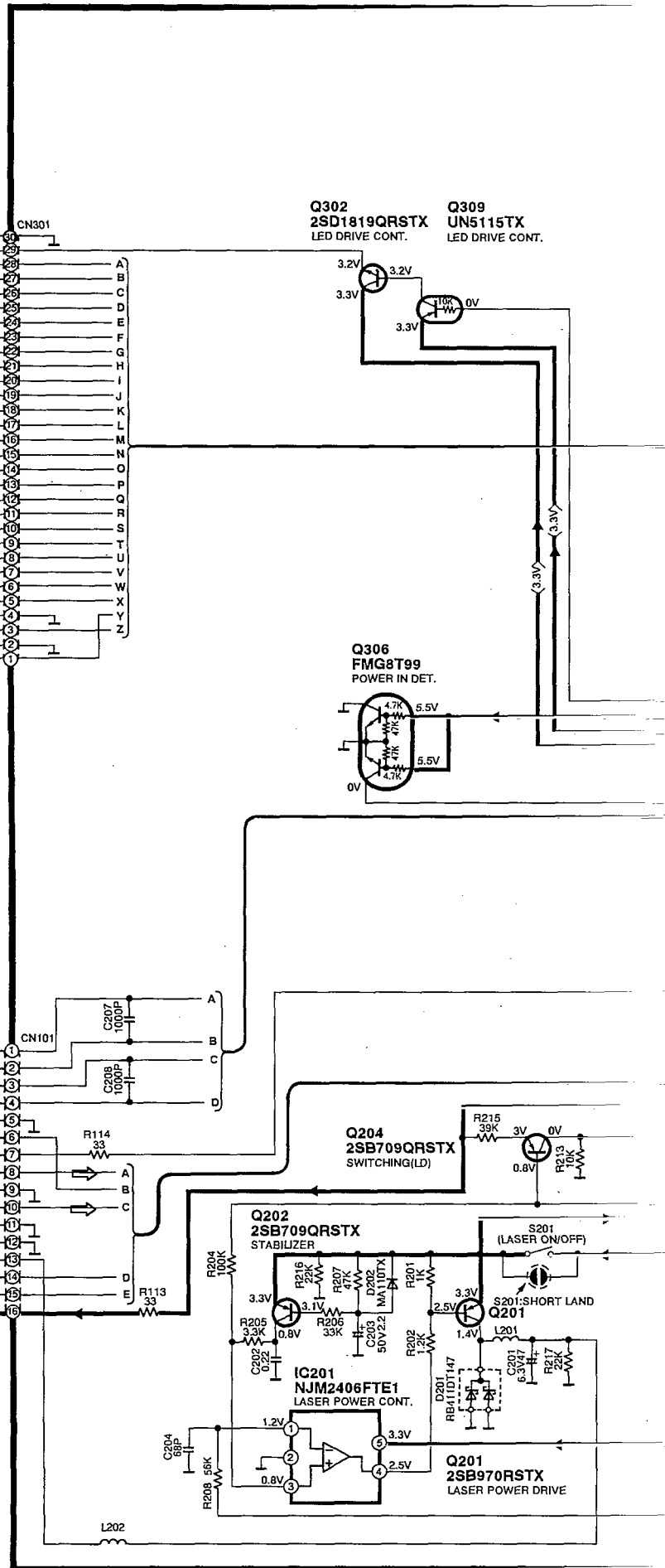

OPTICAL PICKUP

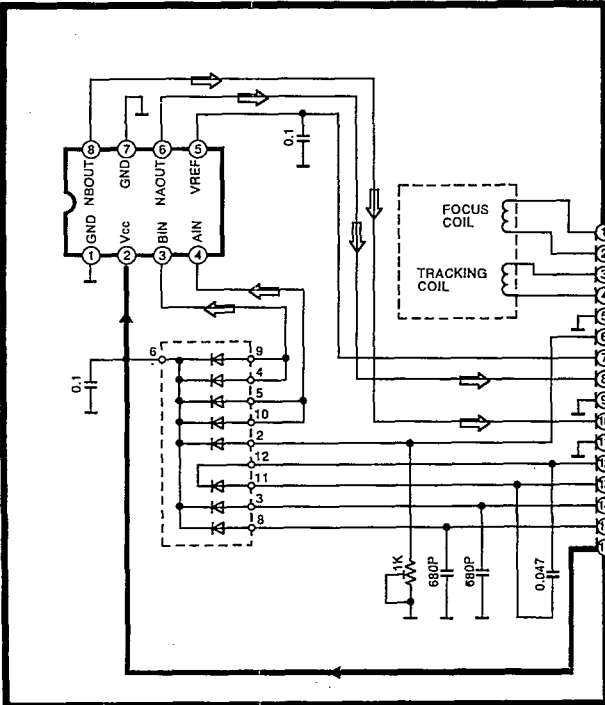

• → : Audio signal lines.

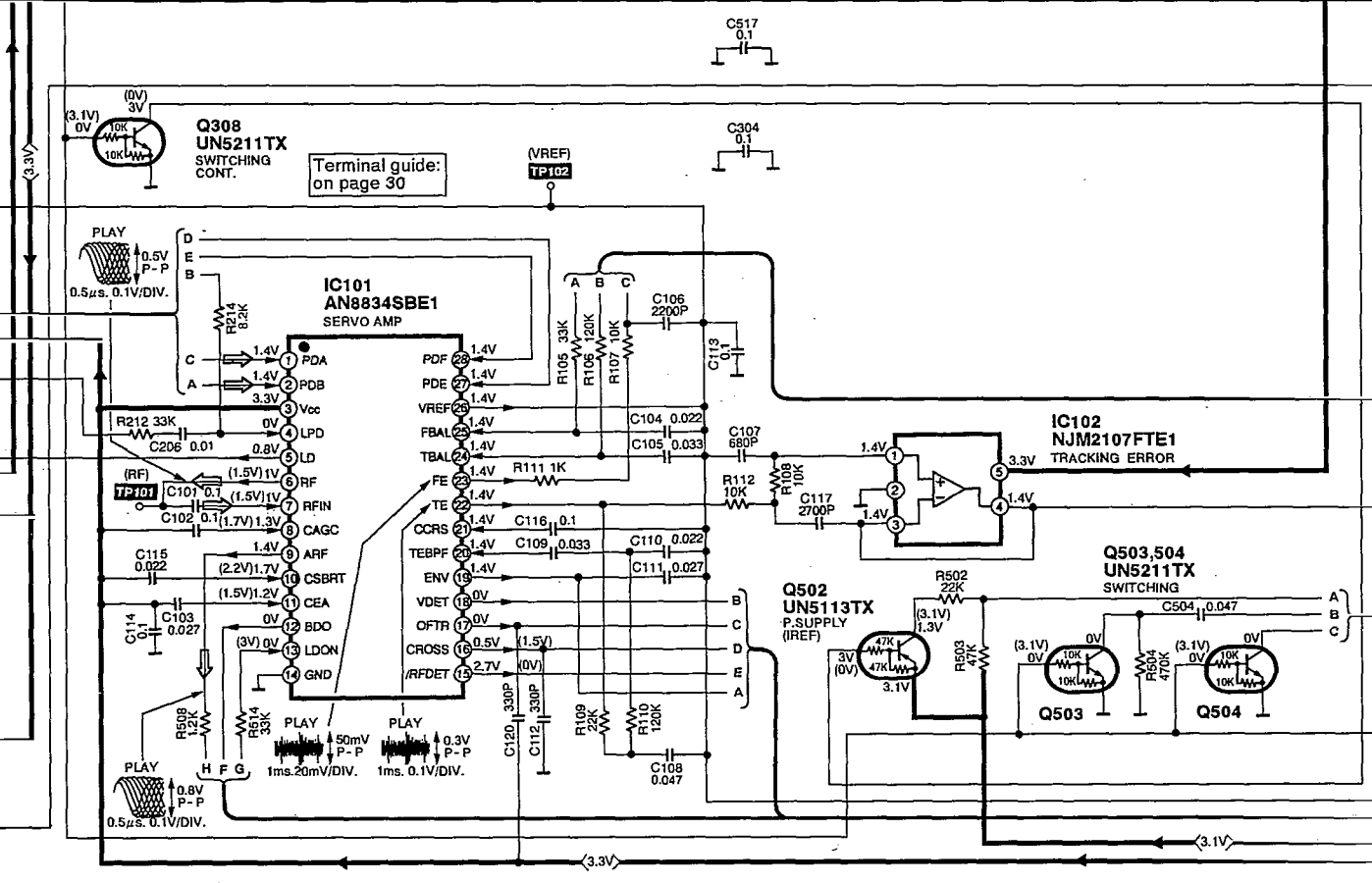
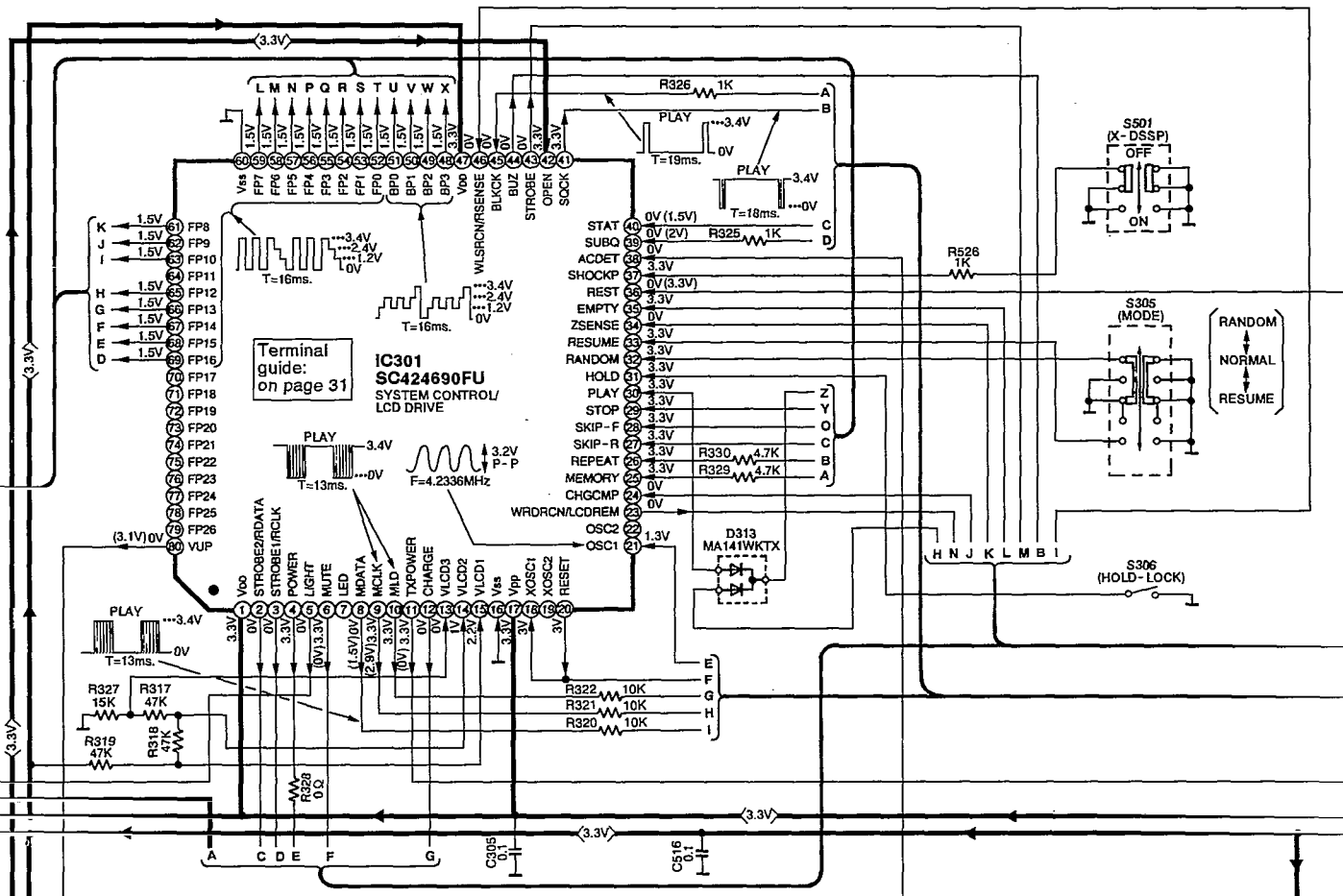

B MAIN CIRCUIT (P.C.Board: on pages 28,29)

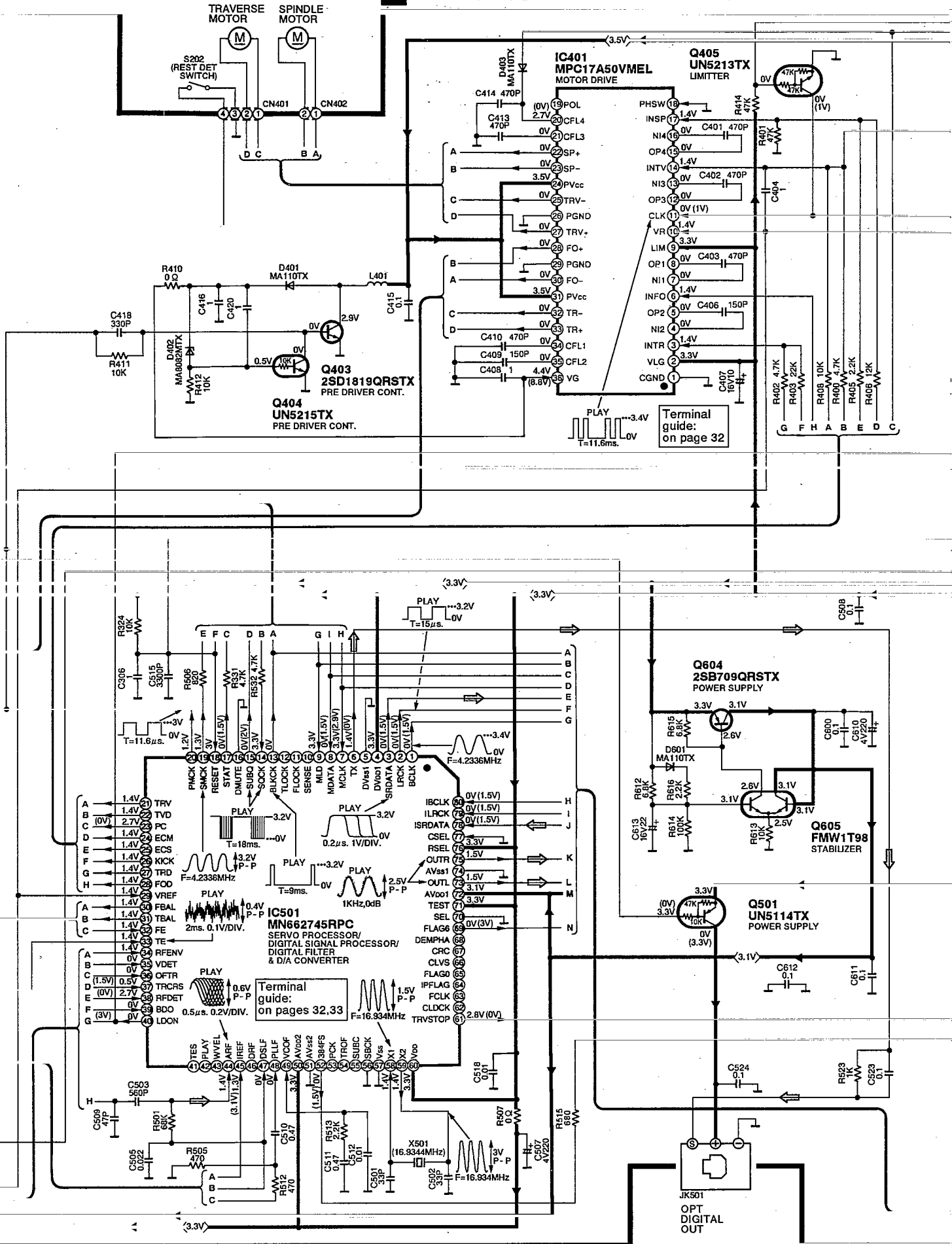

• → : Audio signal lines.

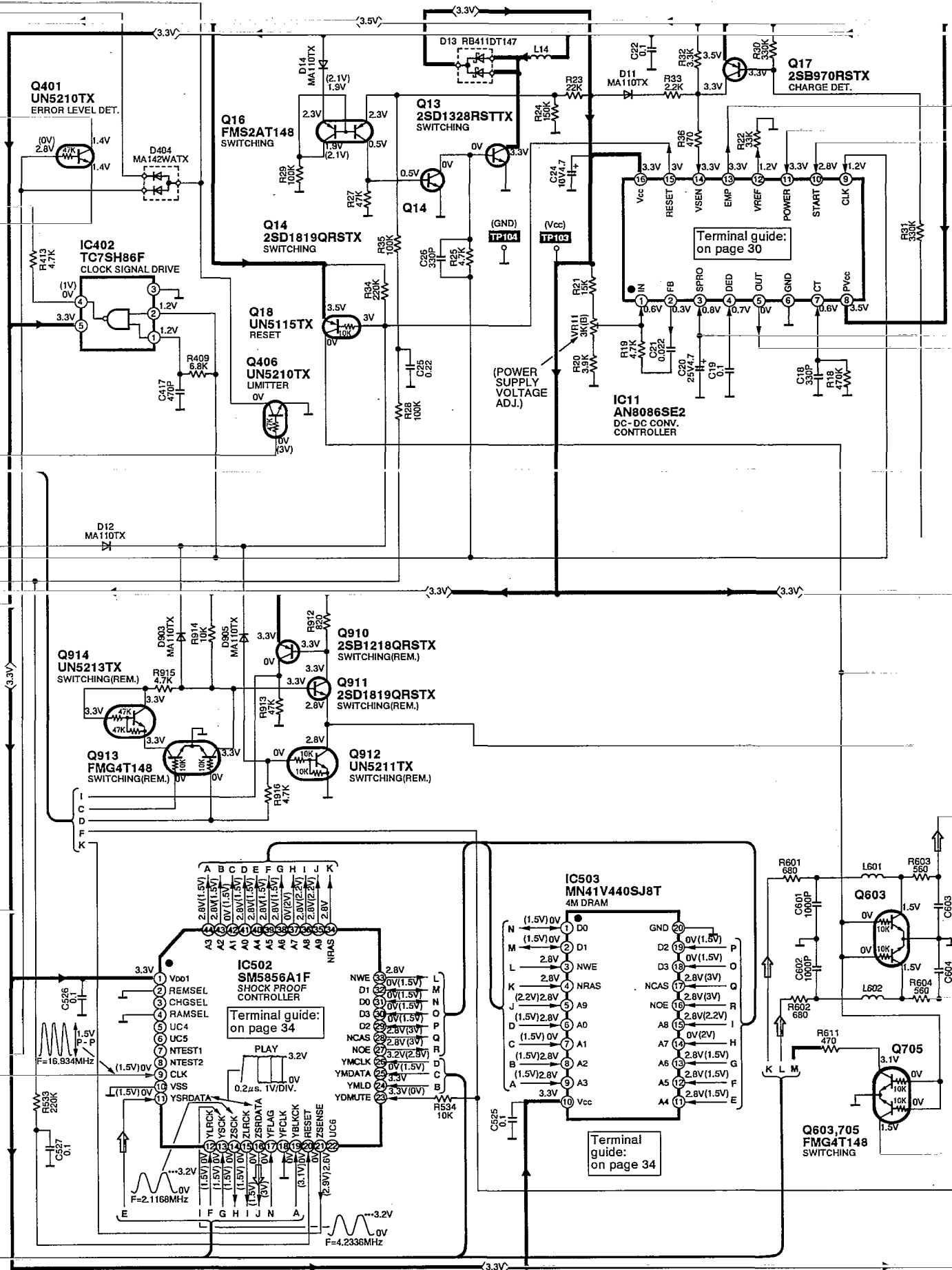

Terminal guide:
on page 30

Terminal guide:
on page 34

Terminal guide:
on page 34

B MAIN CIRCUIT (P.C.Board: on pages 28,29)

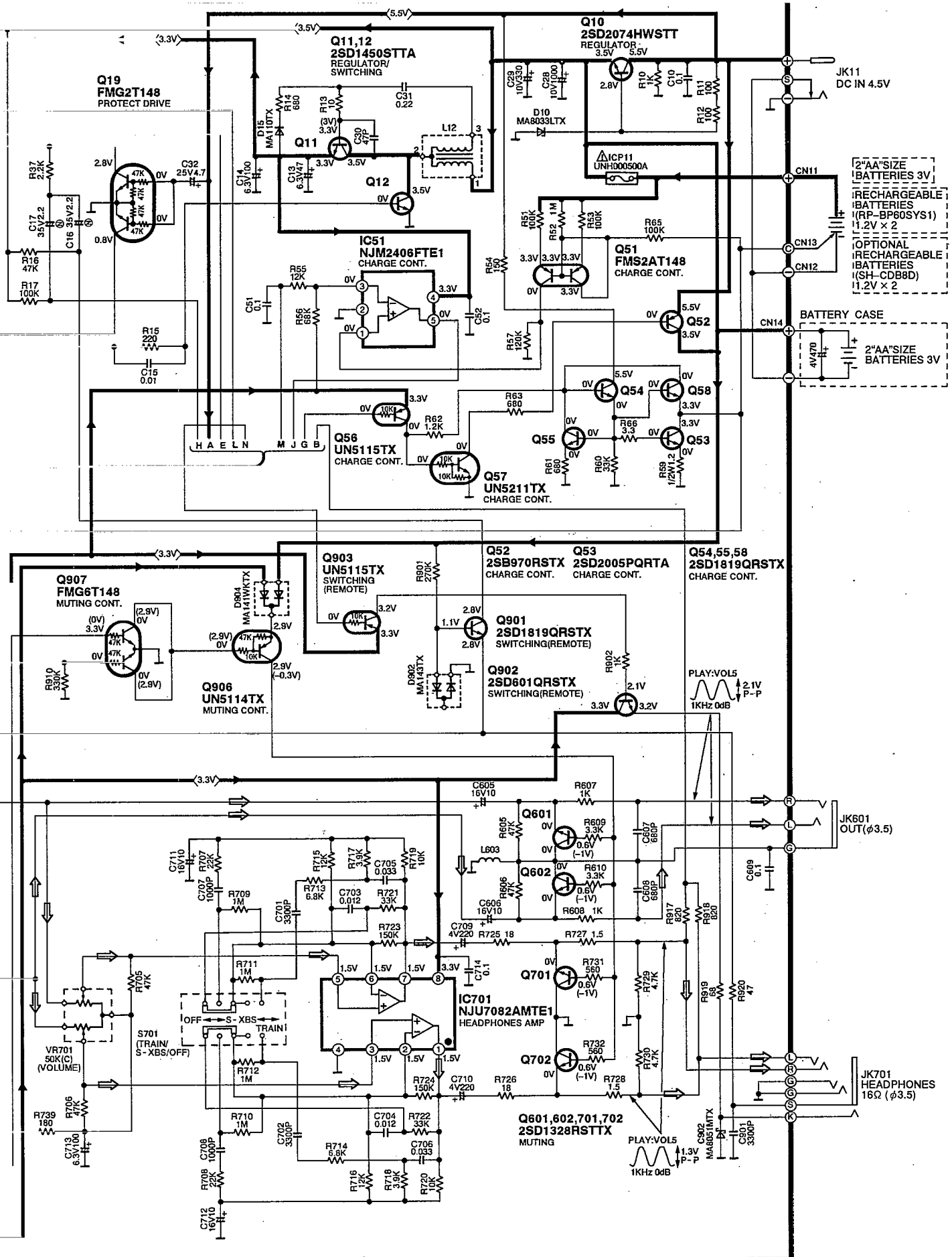

PRINTED CIRCUIT BOARD AND WIRING CONNECTION DIAGRAM

A OPERATION P.C.B. (REP2238B-S)

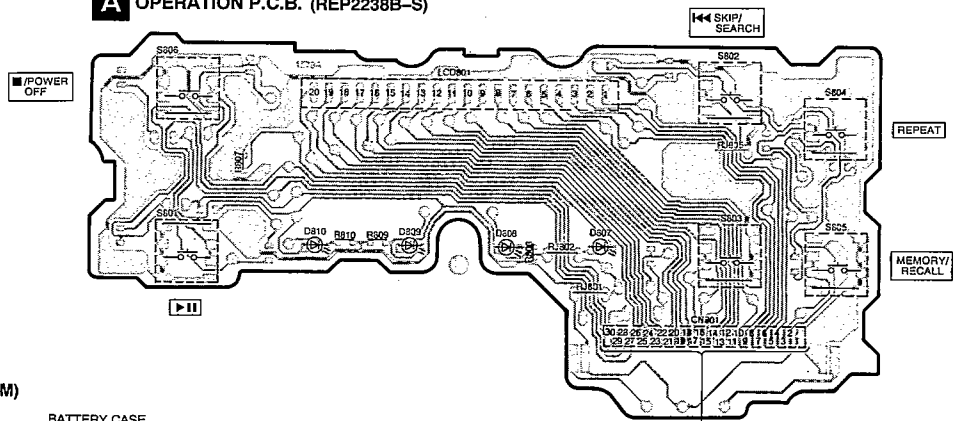

B MAIN P.C.B. (REP2237B-M)

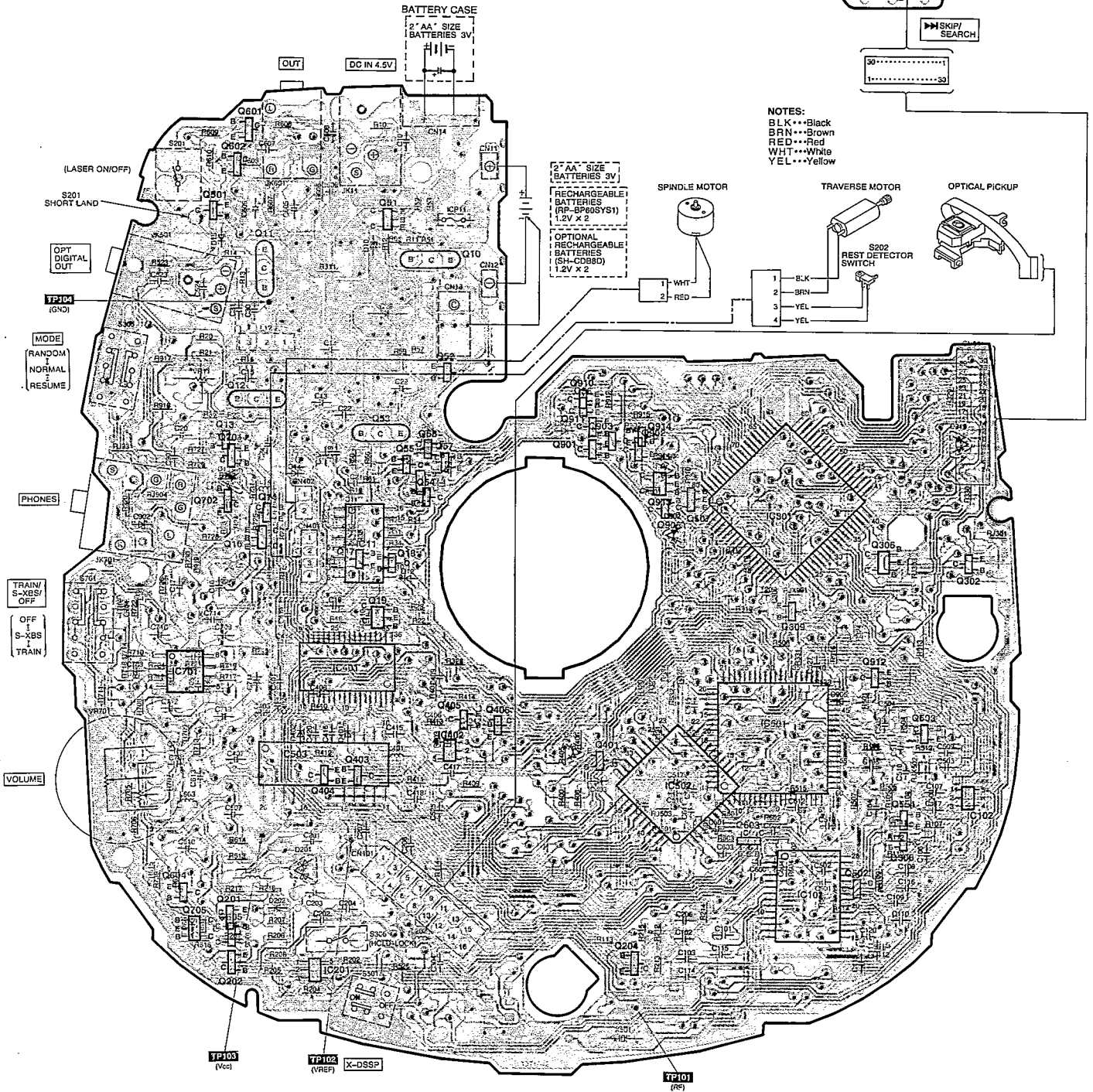

Notes:

- In this printed circuit board diagram, the parts and foil patterns on the board facing toward you are printed in black.
- The opposite side is printed in blue.
- The "●" and "●" marks denote the connection points of double-faced foil patterns (through holes) on both sides of the printed circuit board.
- This printed circuit board diagram may be modified at any time with the development of new technology.

B MAIN P.C.B. (REP2237B-M)

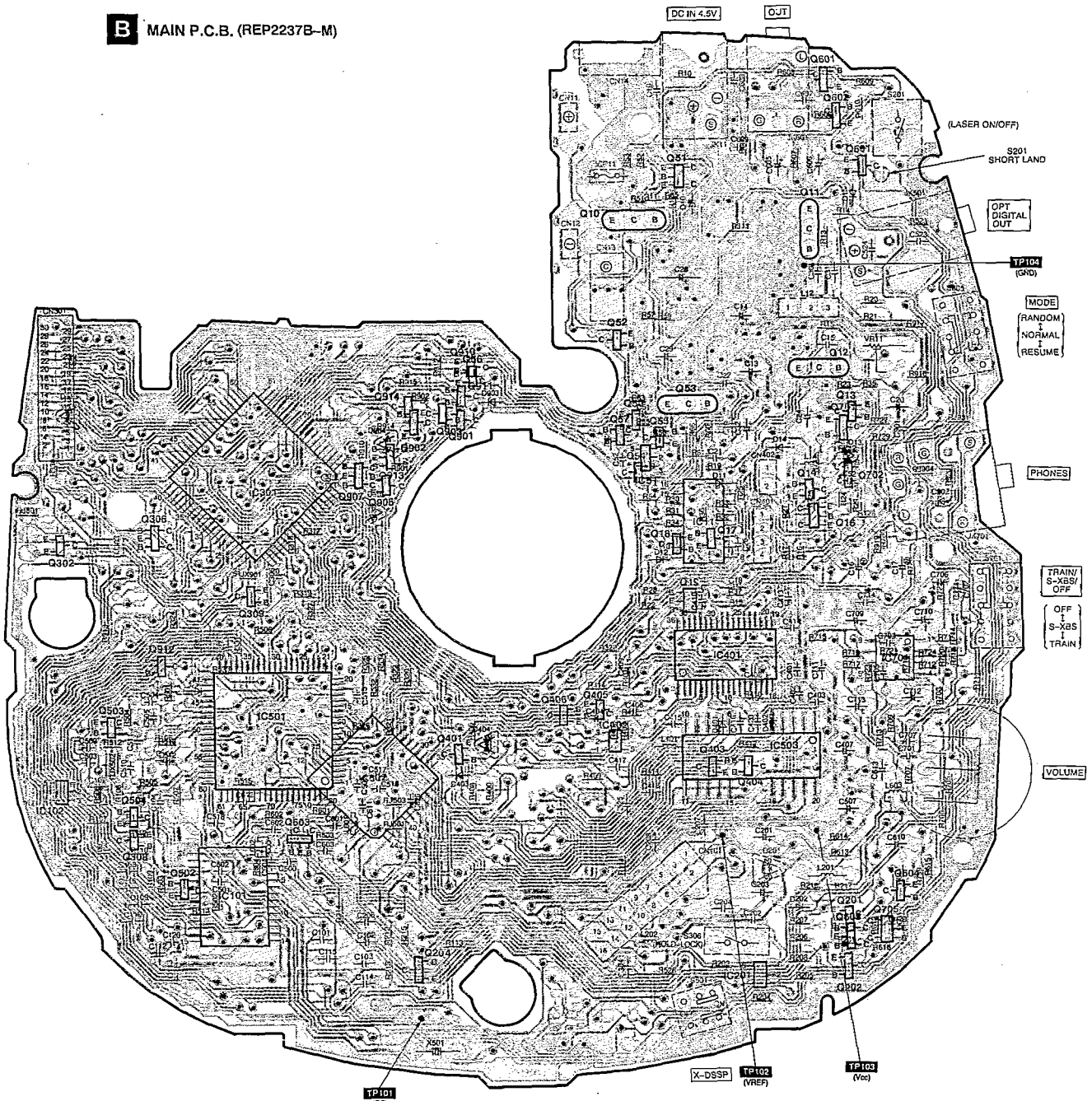

■ TERMINAL GUIDE

● IC11 (AN8086SE2) : DC-DC converter controller

Pin No.	Mark	I/O Division	Function
1	IN	I	Error amp input
2	FB	O	Error amp output
3	SPRO	I	Short protect circuit
4	DED	I	Dead time input
5	OUT	O	Switching output
6	GND	—	GND terminal
7	CT	I	Triangular wave oscillator capacitor input
8	PVCC	I	Power supply terminal

Pin No.	Mark	I/O Division	Function
9	CLK	I	Clock signal input (f=88.2kHz)
10	START	I	Start detection input
11	POWER	I	Power ON/OFF detection terminal
12	VREF	O	Reference voltage input
13	EMP	O	Empty signal output
14	VSEN	I	Empty detect terminal
15	RESET	O	Reset signal input
16	VCC	I	Power supply terminal

● IC101 (AN8834SBE1) : Servo amp.

Pin No.	Mark	I/O Division	Function
1	PDA	I	Focus signal input terminal
2	PDB	I	Focus signal input terminal
3	Vcc	I	Power supply terminal
4	LPD	I	Non-inverting laser power input
5	LD	O	Laser power auto control output
6	RF	O	RF summing output terminal
7	RFIN	I	RF (AGC) signal input
8	CAGC	I	AGC detecting capacitor terminal
9	ARF	O	RF (AGC) signal output
10	CSBRT	I	Capacitor connection terminal for OFTR
11	CEA	I	HPF-amp. terminal
12	BDO	O	Dropout detection output
13	LDON	I	Laser ON/OFF control input
14	GND	—	Ground terminal

Pin No.	Mark	I/O Division	Function
15	/RFDET	O	RFDET output terminal
16	CROSS	O	CROSS signal output
17	OFTR	O	OFTR signal output
18	VDET	O	VDET signal output
19	ENV	O	Envelope signal output
20	TEBPF	I	VDET input terminal
21	CCRS	I	Capacitor connection terminal for CROSS
22	TE	O	Tracking error signal output
23	FE	O	Focus error signal output
24	TBAL	I	Tracking balance signal input
25	FBAL	I	Focus balance signal input
26	VREF	O	Reference voltage output
27	PDE	I	Tracking signal input terminal
28	PDF	I	Tracking signal input terminal

● IC301 (SC424690FU) : System control/LCD drive

Pin No.	Mark	I/O Division	Function
1	V _{DD}	I	Power supply terminal
2	STROBE2	O	Key scan signal output
3	STROBE1		
4	POWER	O	Power ON/OFF signal output
5	LIGHT	O	LCD backlight control signal output
6	MUTE	O	Muting signal output ("H" : MUTE)
7	LED	O	LED drive command signal (Not used, open)
8	MDATE	O	Command data signal output
9	MCLK	O	Command clock output
10	MLD	O	Command load signal output
11	TX POWER	—	Voltage control terminal
12	CHARGE	O	Voltage control terminal
13	VLCD3	I	Power supply terminal
14	VLCD2	I	Power supply terminal
15	VLCD1		
16	V _{SS}	—	GND terminal
17	V _{DD}	I	Power supply terminal
18	XOSC1	I	Reset signal input terminal
19	XOSC2	—	Not used, open
20	RESET	O	Reset detect terminal
21	OSC1	I	Main-system clock input
22	OSC2	—	Not used, open
23	WRDRCN/ LCDREM	O	Remote control signal output
24	CHGCMP	I	Voltage control terminal
25	MEMORY	I	Key input terminal (MEMORY/RECALL)
26	REPEAT	I	Key input terminal (REPEAT)
27	SKIPR	I	Key input terminal (SKIP. R)
28	SKIPF	I	Key input terminal (SKIP. F)
29	STOP	I	Key input terminal (■ / POWER OFF)

Pin No.	Mark	I/O Division	Function
30	PLAY	I	Key input terminal (PLAY/PAUSE)
31	HOLD	I	Key input terminal (HOLD)
32	RANDOM	I	Key input selector terminal
33	RESUME	I	Processing condition (CRC, CUE, CLVS, FCLV, TTSTOP) input
34	ZSENSE	I	Sense signal input
35	EMPTY	I	Empty detection input terminal
36	REST	I	Reset detection terminal
37	SHOCKP	I	
38	ACDET	I	Power supply detection signal input
39	SUBQ	I	Sub-code (Q data) input
40	STAT	I	Status signal (CRC, CUE, CLVS, TTSTOP, FCLV, SQCK) input
41	SQCK	O	Sub-code Q resistor clock output
42	OPEN	I	Disc holder open detection terminal
43	STROBE	O	Voltage control output terminal
44	BUZ	O	Beep control output
45	BLKCK	I	Sub-code block (Q data) clock (75Hz) input
46	WLSRCN/ RSENSE	I	Remote control signal input
47	V _{DD}	I	Power supply terminal
48 } 51	BP3 } BP0	O	LCD segment signal output
52 } 59	FP0 } FP7	O	LCD segment signal output
60	V _{SS}	—	GND terminal
61 } 63	FP8 } FP10	O	LCD segment signal output
64	FP11	—	Not used, open
65 } 69	FP12 } FP16	O	LCD segment signal output
70 } 79	FP17 } FP26	—	LCD segment signal output (Not used, open)
80	VUP	O	Loop filter control output terminal

• IC401 (MPC17A50VMEL) : Motor drive

Pin No.	Mark	I/O Division	Function
1	CGND	—	GND terminal (control circuit)
2	VLG	I	Power supply terminal (control circuit)
3	INTR	I	Tracking coil control signal input
4	NI2	—	Connected to capacitor filter
5	OP2		
6	INFO	I	Focus coil control signal input
7	NI1	—	Connected to capacitor filter
8	OP1		
9	LIM	I	Limit control level signal input
10	VR	I	Voltage control terminal
11	CLK	I	Clock signal input
12	OP3	—	Connected to capacitor filter
13	NI3		
14	INTV	I	Traverse motor control signal input
15	OP4	—	Connected to capacitor filter
16	NI4		
17	INSP	I	Spindle motor control signal input
18	PHSW	I	CH4 mode input terminal
19	POL	—	CH4 monitor output terminal (Not used, open)

Pin No.	Mark	I/O Division	Function
20	CFL4	—	Connected to capacitor filter
21	CFL3		
22	SP+	O	Spindle motor drive signal output
23	SP-		
24	PVCC	I	(CH3, CH4 output) Power supply terminal
25	TRV-	O	Traverse motor drive signal output
26	PGND	—	GND terminal (CH3, CH4 output)
27	TRV+	O	Traverse motor drive signal output
28	FO+	O	Focus coil drive signal output
29	PGND	—	GND terminal (CH1, CH2 output)
30	FO-	O	Focus coil drive signal output
31	PVCC	I	(CH1, CH2 output) Power supply terminal
32	TR-	O	Tracking coil drive signal output
33	TR+		
34	CFL1	—	Connected to capacitor filter
35	CFL2		
36	VG	I	Power supply terminal (Print driver circuit)

• IC501 (MN662745RPC) : Servo processor/digital signal processor/digital filter /D/A converter

Pin No.	Mark	I/O Division	Function
1	BCLK	O	Serial bit clock output
2	LRCK	O	L/R discriminating signal output
3	SRDATA	O	Serial data signal output
4	DV _{bd} 1	I	Power supply (digital circuit) terminal
5	DV _{ss} 1	—	GND (digital circuit) terminal
6	TX	—	Digital audio interface signal (Not used, open)
7	MCLK	I	Command clock signal
8	MDATA	I	Command data signal
9	MLD	I	Command load signal ("L" : LOAD)
10	SENSE	—	Sense signal (OFT, FESL, NACEND, NAJEND, POSAD, SFG) (Not used, open)
11	FLOCK	—	Optical servo condition (focus) ("L" : lead-in) (Not used, open)
12	TLOCK	—	Optical servo condition (tracking) ("L" : lead-in) (Not used, open)

Pin No.	Mark	I/O Division	Function
13	BLKCK	O	Sub-code block clock (f=75Hz)
14	SQCK	I	Sub-code Q register clock
15	SUBQ	O	Sub-code Q data
16	DMUTE	—	Muting input ("H" : MUTE) (Not used, connected to GND)
17	STAT	O	Status signal (CRC, CUE, CLVS, TTSTOP, FCLV, SQCK)
18	RESET	I	Reset signal ("L" : reset)
19	SMCK	O	System clock (f=4.2336MHz)
20	PMCK	O	Frequency division clock signal (f=1/1.92×ck=88.2kHz)
21	TRV	O	Traverse servo control
22	TVD	O	Traverse drive signal
23	PC	O	Turntable motor drive signal ("L" : ON)
24	ECM	O	Turntable motor drive signal (Forced mode)
25	ECS	O	Turntable motor drive signal (Servo error signal)

Pin No.	Mark	I/O Division	Function
26	KICK	O	Kick pulse output
27	TRD	O	Tracking drive signal output
28	FOD	O	Focus drive signal output
29	VREF	I	D/A drive output (TVD, ECS, TRD, FOD, FBAL, TBAL) normal voltage input terminal
30	FBAL	O	Focus balance adj. output
31	TBAL	O	Tracking balance adj. output
32	FE	I	Focus error signal (analog input)
33	TE	I	Tracking error signal (analog input)
34	RFENV	I	RF envelope signal
35	VDET	I	Oscillation det. signal ("H" : det)
36	OFTR	I	Off track signal ("H" : Off track)
37	TRCRS	I	Track cross signal input
38	RFDET	I	RF detection signal ("L" : detection)
39	BDO	I	Dropout detection signal ("H" : dropout)
40	LDON	O	Laser power control ("H" : ON)
41	TES	—	Tracking error shunt output ("H" : dropout)
42	PLAY	—	Play signal ("H" : play)
43	WVEL	—	Double velocity status signal ("H" : double)
44	ARF	I	RF signal input
45	IREF	I	Reference current input
46	DRF	—	DSL bias terminal (Not used, open)
47	DSL F	I/O	DSL loop filter terminal
48	PLL F	I/O	PLL loop filter terminal
49	VCO F	I	VCO loop filter terminal (Not used, connected to AV _{DD2})
50	AV _{DD2}	I	Power supply (analog circuit) terminal (2)
51	AV _{SS2}	—	GND (analog circuit) terminal
52	FS384	O	384fs (16.9344MHz) output
53	PCK	—	PLL extract clock (f=4.3218MHz) (Not used, open)
54	TROF	—	Tracking servo OFF signal (Not used, open)

Pin No.	Mark	I/O Division	Function
55	SUBC	—	Sub-code serial output data (Not used, open)
56	SBCK	—	Sub-code serial input clock (Not used, connected to GND)
57	V _{SS}	—	GND terminal
58	X1	I	Crystal oscillator terminal (f=16.9344MHz)
59	X2	O	
60	V _{DD}	I	Power supply terminal
61	TRVSTOP	O	Traverse motor stop control terminal
62	CLDCK	—	Sub-code frame clock signal (f CLDCK=7.35kHz: Normal) (Not used, open)
63	FCLK	—	Crystal frame clock
64	IPFLAG	—	Interpolation flag terminal (Not used, open)
65	FLAG0	—	Flag terminal (Not used, open)
66	CLVS	—	Turntable servo phase synchro signal ("H": CLV, "L": Rough servo) (Not used, open)
67	CRC	—	Sub-code CRC check terminal ("H": OK, "L": NG) (Not used, open)
68	DEMPHA	—	De-emphasis ON signal ("H": ON) (Not used, open)
69	FLAG6	O	Flag terminal
70	SEL	—	Not used, connected to GND
71	TEST	I	Test terminal (Normal : "H")
72	AV _{DD1}	I	Power supply (analog circuit) terminal (1)
73	OUTL	O	Lch audio signal
74	AV _{DD1}	—	GND (analog circuit) terminal (1)
75	OUTR	O	Rch audio signal
76	RSEL	I	Polarity direction control terminal of RF signal (Not used, connected to power supply)
77	CSEL	I	Frequency control terminal of crystal oscillator
78	ISRDATA	I	Serial data signal input
79	ILRCK	I	L/R discriminating signal input
80	IBCLK	I	Serial bit clock input

• IC502 (SM5856A1F) : Shock proof controller

Pin No.	Mark	I/O Division	Function
1	V _{DD} 1	I	Power supply terminal
2	REMSEL	—	Key input terminal (ANTI-SHOCK MEMORY)
3	CHGSEL	—	Key input terminal (Not used, open)
4	RAMSEL	—	Not used, open
5	UC4	—	Not used, open
6	UC5	—	Sound quality/sound field control terminal
7	NTEST1	—	Test terminal (Not used, open)
8	NTEST2		
9	CLK	I	Clock signal input (f=16.9344MHz)
10	V _{SS}	—	GND terminal
11	YSRDATA	I	Serial data input terminal
12	YLCK	I	L/R clock input terminal
13	YSCK	I	Serial bit clock input terminal
14	ZSCK	O	Serial bit clock output terminal
15	ZLCK	O	L/R clock output terminal
16	ZSRDATA	O	Serial data output terminal
17	YFLAG	I	RAM over-flow flag terminal
18	YFCLK	I	Crystal frame clock input

Pin No.	Mark	I/O Division	Function
19	YBLKCK	I	Sub-code block clock input terminal
20	RESET	I	Reset input terminal
21	ZSENSE	O	Microcomputer states output terminal
22	UC6	—	Not used, open
23	YDMUTE	I	Mute input terminal
24	YMLD	I	Microcomputer latch clock input terminal
25	YMDATA	I	Microcomputer serial data input terminal
26	YMCLK	I	Microcomputer shift clock input terminal
27	NOE	O	D-RAM output enable terminal
28	NCAS	O	D-RAM column address strobe terminal
29 ┆ 32	D0 ┆ D3	I/O	D-RAM data input/output terminal
33	NWE	O	D-RAM write enable terminal
34	NRAS	O	D-RAM low address strobe terminal
35 ┆ 44	A0 ┆ A9	O	D-RAM address output terminal

• IC503 (MN41V440SJ8T) : 4M DRAM

Pin No.	Mark	I/O Division	Function
1	D0	I/O	Data input/output terminal
2	D1	I/O	Data input/output terminal
3	NWE	I	Write enable terminal
4	NRAS	I	Low address strobe terminal
5	A9	I	Address input terminal
6	A0	I	Address input terminal
7 ┆ 9	A1 ┆ A3	I	Address input terminal

Pin No.	Mark	I/O Division	Function
10	VCC	I	Power supply terminal
11 ┆ 15	A4 ┆ A8	I	Address input terminal
16	NOE	I	Output enable terminal
17	NCAS	I	Column address strobe terminal
18	D3	I	Data input terminal
19	D2	I	Data input terminal
20	GND	—	GND terminal

REPLACEMENT PARTS LIST

Notes: * Important safety notice:

 Components identified by Δ mark have special characteristics important for safety.

Furthermore, special parts which have purposes of fire-retardant (resistors), high-quality sound (capacitors), low-noise (resistors), etc. are used.

When replacing any of components, be sure to use only manufacturer's specified parts shown in the parts list.

* Warning: This product uses a laser diode. Refer to caution statements on page 2.

Ref. No.	Part No.	Part Name & Description	Remarks	Ref. No.	Part No.	Part Name & Description	Remarks
		INTEGRATED CIRCUIT(S)		Q503, 504	UN5211TX	TRANSISTOR	
IC11	AN8086SE2	DC-DC CONV. CONTROLLER		Q601, 602	2SD1328QRSTX	TRANSISTOR	
IC51	NJM2406FTE1	CHARGE CONT.		Q603	FMG4T148	TRANSISTOR	
IC101	AN8834SBE1	SERVO AMP		Q604	2SB709QRSTX	TRANSISTOR	
IC102	NJM2107FTE1	TRACKING ERROR		Q605	FMW1T98	TRANSISTOR	
IC201	NJM2406FTE1	LASER POWER CONT.		Q701, 702	2SD1328QRSTX	TRANSISTOR	
IC301	SC424690FU	SYSTEM CONTROL/LCD DRIVE		Q705	FMG4T148	TRANSISTOR	
IC401	MPC17A50VMEL	MOTOR DRIVE		Q901	2SD1819QRSTX	TRANSISTOR	
IC402	TC7SH86F	CLOCK SIGNAL DRIVE		Q902	2SD601QRSTX	TRANSISTOR	
IC501	MN662745RPC	SERVO PROCESSOR		Q903	UN5115TX	TRANSISTOR	
IC502	SM5856A1F	SHOCK PROOF CONTROLLER		Q906	UN5114TX	TRANSISTOR	
IC503	MN41V440SJ8T	4M DRAM		Q907	FMG6T148	TRANSISTOR	
IC701	NJU7082AMTE1	HEADPHONES AMP		Q910	2SB1218QRSTX	TRANSISTOR	
		TRANSISTOR(S)		Q911	2SD1819QRSTX	TRANSISTOR	
				Q912	UN5211TX	TRANSISTOR	
Q10	2SD2074HWSTT	TRANSISTOR		Q913	FMG4T148	TRANSISTOR	
Q11, 12	2SD1450STTA	TRANSISTOR		Q914	UN5213TX	TRANSISTOR	
Q13	2SD1328QRSTX	TRANSISTOR				DIODE(S)	
Q14	2SD1819QRSTX	TRANSISTOR		D10	MA8033LTX	DIODE	
Q16	FMS2AT148	TRANSISTOR		D11, 12	MA110TX	DIODE	
Q17	2SB970RSTX	TRANSISTOR		D13	RB411DT147	DIODE	
Q18	UN5115TX	TRANSISTOR		D14, 15	MA110TX	DIODE	
Q19	FMG2T148	TRANSISTOR		D201	RB411DT147	DIODE	
Q51	FMS2AT148	TRANSISTOR		D202	MA110TX	DIODE	
Q52	2SB970RSTX	TRANSISTOR		D313	MA141WKTIX	DIODE	
Q53	2SD2005PQRTA	TRANSISTOR		D401	MA110TX	DIODE	
Q54, 55	2SD1819QRSTX	TRANSISTOR		D402	MA8082MTIX	DIODE	
Q56	UN5115TX	TRANSISTOR		D403	MA110TX	DIODE	
Q57	UN5211TX	TRANSISTOR		D404	MA142WATX	DIODE	
Q58	2SD1819QRSTX	TRANSISTOR		D601	MA110TX	DIODE	
Q201	2SB970RSTX	TRANSISTOR		D807-810	LNJ310M6URA	L. E. D.	
Q202	2SB709QRSTX	TRANSISTOR		D902	MA143TX	DIODE	
Q204	2SB709QRSTX	TRANSISTOR		D903	MA110TX	DIODE	
Q302	2SD1819QRSTX	TRANSISTOR		D904	MA141WKTIX	DIODE	
Q306	FMG8T99	TRANSISTOR		D905	MA110TX	DIODE	
Q308	UN5211TX	TRANSISTOR		C902	MA8051MTIX	DIODE	
Q309	UN5115TX	TRANSISTOR				IC PROTECTOR(S)	
Q401	UN5210TX	TRANSISTOR		ICP11	UNH000500A	IC PROTECTOR	Δ
Q403	2SD1819QRSTX	TRANSISTOR				VARIABLE RESISTOR(S)	
Q404	UN5215TX	TRANSISTOR		VR11	EVNDXAA00B33	POWER SUPPLY VOLTAGE ADJ.	
Q405	UN5213TX	TRANSISTOR		VR701	EVUT2EA25C54	VOLUME	
Q406	UN5210TX	TRANSISTOR					
Q501	UN5114TX	TRANSISTOR					
Q502	UN5113TX	TRANSISTOR					

Ref. No.	Part No.	Part Name & Description	Remarks	Ref. No.	Part No.	Part Name & Description	Remarks
		COIL (S)				CABINET AND CHASSIS	
L12	RLZ0028T-M	COIL		1	RKK0065-KJ	BATTERY COVER	
L14	RLQU331KT-W	COIL		2	RGV0145-K	MODE/TRAIN, S-XBS KNOB	
L201	RLQB471KT-K	COIL		3	RGV0171-H	OPT OUT/X-DSSP KNOB	
L202	ELJPC330KF	COIL		4	RJC93020	COMMON BATTERY TERMINAL	
L401	RLQU331KT-W	COIL		5	RFKJLS600GKK	BOTTOM CABINET ASS'Y	
L601-603	RLBV102V-Y	COIL		5-1	RKAD063-K	FOOT	
		OSCILLATOR (S)		6	RMA0677	REAR ORNAMENT	
X501	RSXC16M9S01T	OSCILLATOR (16.9344MHz)		7	RMS0105-1	SHAFT	
		LCD (S)		8	RFKLLS600-K	CD COVER ASS'Y	
LCD801	RSL5153-L	LCD		9	RGU1375B-K	OPERATION BUTTON (A)	
		SWITCH (ES)		10	RGU1376B-K	OPERATION BUTTON (B)	
S201	ESE11SV1	LASER ON/OFF		11	RFKNLS600GKK	HOLD LOCK KNOB ASS'Y	
S202	SSH01-2	REST DETECTOR		12	RHE5119YA	SCREW	
S305	ESD11H230	MODE (RANDOM/NORMAL/RESUME)		13	RMA0935	HOLD LOCK LEVER	
S306	RSM0006-P	HOLD-LOCK		14	RME0163	HOLD SPRING	
S501	ESD11H220	OPT OUT/X-DSSP		15	RMZ0366	FPC SHEET	
S701	ESD11H230	TRAIN, S-XBS, OFF		16	RHE5155YA	SCREW	
S801	RSG0030-P	PLAY/PAUSE		17	RJB1582A	FFC (30P)	
S802	RSG0030-P	SKIP/SEARCH (B)		18	RJF0027	LCD HOLDER	
S803	RSG0030-P	SKIP/SEARCH (F)		19	RMA0936	LID COVER	
S804	RSG0030-P	REPEAT		20	RMA0937	LCD PLATE	
S805	RSG0030-P	MEMORY/RECALL		21	ESQ0048	ZEBRA RUBBER	
S806	RSG0030-P	STOP/POWER OFF		22	RGU1377-K	OPEN BUTTON	
		CONNECTOR (S) AND SOCKET (S)		23	RFKLLS600-K	INTERMEDIATE CABINET ASS'Y	
CN11	RJC93015-1	BATTERY TERMINAL (+)		23-1	RMG0397-K	CUSHION RUBBER	
CN12	RJC93015-1	BATTERY TERMINAL (-)		24	RMB0390	PUSH SPRING	
CN13	RJH5102-1	RECHARGEABLE BATT. TERMINAL		25	RML0441	OPEN LEVER	
CN14	RJH9208	BATT. CASE CONNECT. TERMINAL		26	RMS0462	PUSH SHAFT	
CN101	RJU035T016-1	SOCKET (16P)		27	XTN17+6GFZ	SCREW	
CN301	RJS1A8830T	CONNECTOR (30P)		28	RAE0140Z	TRAVERSE DECK	
CN401	RJT068W04V	CONNECTOR (4P)		28-1	SHGD157	FLOATING RUBBER (1)	
CN402	RJT068W02V	CONNECTOR (2P)		28-2	SHGD165	FLOATING RUBBER (2)	
CN801	RJS2A2230T	CONNECTOR (30P)		29	RMA0987	EARTH PLATE	
		JACK (S)		30	RMG0443-K	STOPPER RUBBER	
JK11	RJJ43K09-C	DC IN JACK		31	RMZ0365	LCD SHEET	
JK501	GP1F366X	OPTICAL DIGITAL OUT					
JK601	RJJD3S5ZB-C	OUT JACK					
JK701	RJJ36T02-C	HEADPHONES JACK					

CABINET PARTS LOCATION

Note: When changing loading mechanism parts, apply the specified grease to the areas marked "X" as shown in the drawing.

Ref. No.	Part No.
①	RFKXPG671

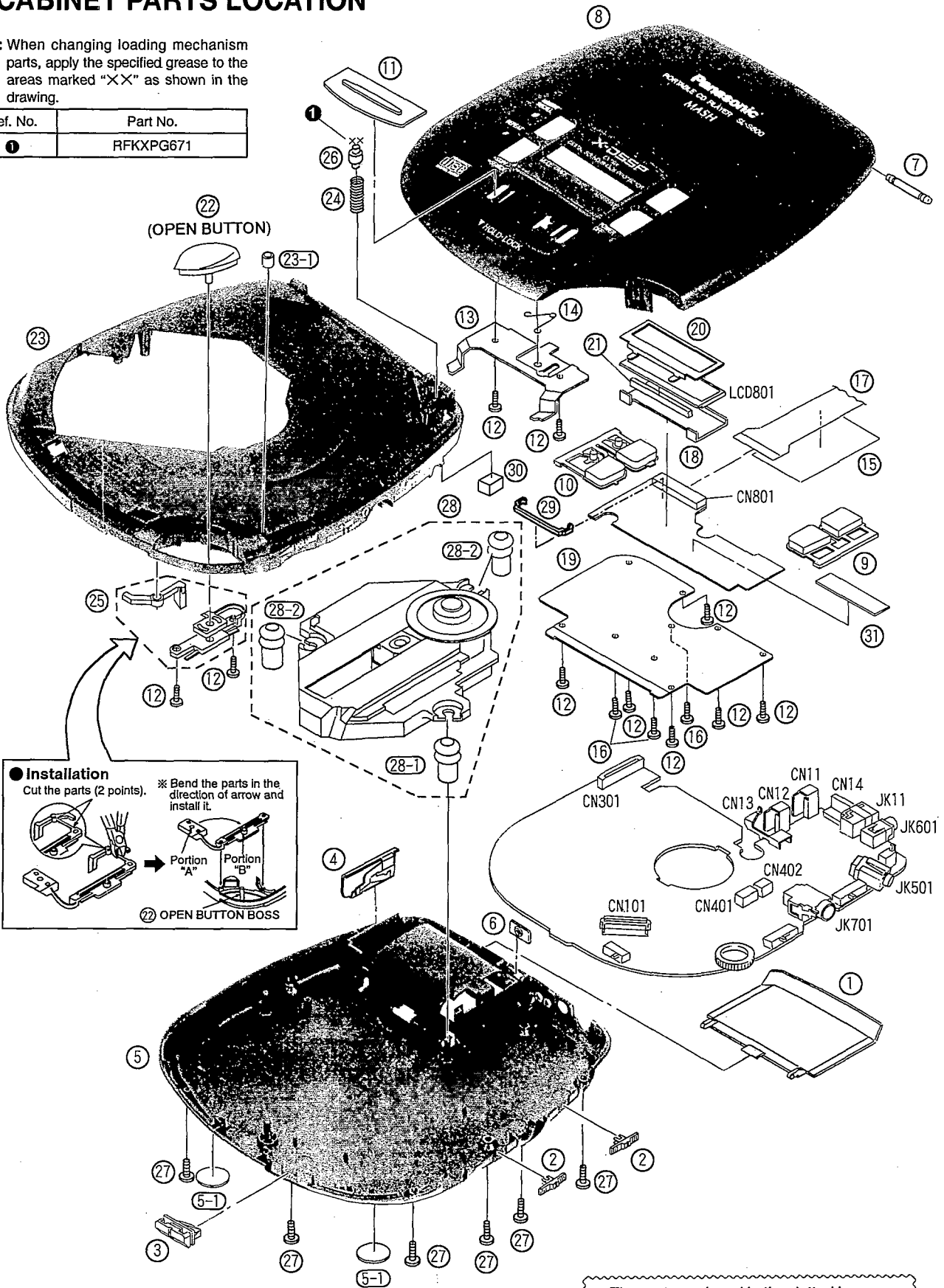

● Installation
Cut the parts (2 points).
※ Bend the parts in the direction of arrow and install it.

Portion "A" Portion "B"
② OPEN BUTTON BOSS

The parts enclosed in the dotted boxes are supplied as a block assembly. Therefore, they are not supplied separately except parts indicated with Ref. No.

RESISTORS AND CAPACITORS

Notes: * Capacity values are in microfarads (μF) unless specified otherwise, P=Pico-farads (pF) F=Farads (F)
 * Resistance values are in ohms, unless specified otherwise, 1K=1,000 (OHM), 1M=1,000k (OHM)

Ref. No.	Part No.	Values & Remarks	Ref. No.	Part No.	Values & Remarks	Ref. No.	Part No.	Values & Remarks
		RESISTORS	R201	ERJ6GEYJ102V	1/10W 1K	R607, 608	ERJ6GEYJ102V	1/10W 1K
			R202	ERJ6GEYJ122V	1/10W 1.2K	R609, 610	ERJ6GEYJ332V	1/10W 3.3K
			R204	ERJ6GEYJ104V	1/10W 100K	R611	ERJ6GEYJ471V	1/10W 470
R10	ERJ6GEYJ102V	1/10W 1K	R205	ERJ6GEYJ332V	1/10W 3.3K	R612	ERJ3GEYJ682V	1/16W 6.8K
R11, 12	ERJ6GEYJ101V	1/10W 100	R206	ERJ6GEYJ333V	1/10W 33K	R613	ERJ6GEYJ103V	1/10W 10K
R13	ERJ6GEYJ100	1/10W 10	R207	ERJ6GEYJ473V	1/10W 47K	R614	ERJ6GEYJ104V	1/10W 100K
R14	ERJ6GEYJ681V	1/10W 680	R208	ERJ6GEYJ563V	1/10W 56K	R615	ERJ3GEYJ682V	1/16W 6.8K
R15	ERJ6GEYJ221V	1/10W 220	R212	ERJ6GEYJ333V	1/10W 33K	R616	ERJ3GEYJ222V	1/16W 2.2K
R16	ERJ3GEYJ473V	1/16W 47K	R213	ERJ6GEYJ103V	1/10W 10K	R705, 706	ERJ6GEYJ473V	1/10W 47K
R17	ERJ3GEYJ104V	1/16W 100K	R214	ERJ6GEYJ822V	1/10W 8.2K	R707, 708	ERJ3GEYJ223V	1/16W 22K
R18	ERJ6GEYJ474V	1/10W 470K	R215	ERJ6GEYJ393V	1/10W 39K	R709	ERJ3GEYJ105V	1/16W 1M
R19	ERJ3GEYJ472V	1/16W 4.7K	R216, 217	ERJ6GEYJ223V	1/10W 22K	R710, 711	ERJ6GEYJ105	1/10W 1M
R20	ERJ6GEYJ392V	1/10W 3.9K	R317-319	ERJ3GEYJ473V	1/16W 47K	R712	ERJ3GEYJ105V	1/16W 1M
R21	ERJ6GEYJ153V	1/10W 15K	R320-322	ERJ3GEYJ103V	1/16W 10K	R713, 714	ERJ3GEYJ682V	1/16W 6.8K
R22	ERJ6GEYJ333V	1/10W 33K	R324	ERJ3GEYJ103V	1/16W 10K	R715, 716	ERJ3GEYJ123V	1/16W 12K
R23	ERJ3GEYJ223V	1/16W 22K	R325, 326	ERJ3GEYJ102V	1/16W 1K	R717, 718	ERJ3GEYJ392V	1/16W 3.9K
R24	ERJ3GEYJ154V	1/16W 150K	R327	ERJ3GEYJ153V	1/16W 15K	R719, 720	ERJ3GEYJ103V	1/16W 10K
R25	ERJ3GEYJ472V	1/16W 4.7K	R329-331	ERJ6GEYJ472V	1/10W 4.7K	R721	ERJ3GEYJ333V	1/16W 33K
R27	ERJ3GEYJ473V	1/16W 47K	R400	ERJ6GEYJ472V	1/10W 4.7K	R722	ERJ6GEYJ333V	1/10W 33K
R28, 29	ERJ3GEYJ104V	1/16W 100K	R401	ERJ6GEYJ473V	1/10W 47K	R723, 724	ERJ3GEYJ154V	1/16W 150K
R30, 31	ERJ3GEYJ334V	1/16W 330K	R402	ERJ3GEYJ472V	1/16W 4.7K	R725, 726	ERJ6GEYJ180V	1/10W 18
R32	ERJ3GEYJ332V	1/16W 3.3K	R403	ERJ3GEYJ223V	1/16W 22K	R727, 728	ERJ6GEYJ185V	1/10W 1.5
R33	ERJ3GEYJ222V	1/16W 2.2K	R405	ERJ6GEYJ222V	1/10W 2.2K	R729, 730	ERJ6GEYJ472V	1/10W 4.7K
R34	ERJ3GEYJ224V	1/16W 220K	R406	ERJ6GEYJ123V	1/10W 12K	R731, 732	ERJ6GEYJ561V	1/10W 560
R35	ERJ3GEYJ104V	1/16W 100K	R408	ERJ6GEYJ103V	1/10W 10K	R739	ERJ6GEYJ181V	1/10W 180
R36	ERJ3GEYJ471V	1/16W 470	R409	ERJ6GEYJ682V	1/10W 6.8K	R807-810	ERJ3GEYJ560V	1/16W 56
R37	ERJ3GEYJ222V	1/16W 2.2K	R411, 412	ERJ6GEYJ103V	1/10W 10K	R901	ERJ3GEYJ274V	3W 270K
R51	ERJ3GEYJ104V	1/16W 100K	R413	ERJ6GEYJ472V	1/10W 4.7K	R902	ERJ3GEYJ102V	1/16W 1K
R52	ERJ3GEYJ105V	1/16W 1M	R414	ERJ6GEYJ473V	1/10W 47K	R910	ERJ3GEYJ334V	1/16W 330K
R53	ERJ3GEYJ104V	1/16W 100K	R501	ERJ3GEYJ683V	1/16W 68K	R912	ERJ6GEYJ821V	1/10W 820
R54	ERJ6GEYJ151V	1/10W 150	R502	ERJ3GEYJ223V	1/16W 22K	R913	ERJ6GEYJ473V	1/10W 47K
R55	ERJ3GEYJ123V	1/16W 12K	R503	ERJ3GEYJ473V	1/16W 47K	R914	ERJ6GEYJ103V	1/10W 10K
R56	ERJ3GEYJ683V	1/16W 68K	R504	ERJ3GEYJ474V	1/16W 470K	R915, 916	ERJ6GEYJ472V	1/10W 4.7K
R57	ERJ3GEYJ124V	1/16W 120K	R505	ERJ6GEYJ471V	1/10W 470	R917, 918	ERJ6GEYJ821V	1/10W 820
R59	ERJ12YJ1R2H	1/2W 1.2	R506	ERJ3GEYJ821V	1/16W 820	R919	ERJ3GEYJ680V	3W 68
R60	ERJ6GEYJ333V	1/10W 33K	R508	ERJ3GEYJ122V	1/16W 1.2K	R920	ERJ6GEYJ470V	1/10W 47
R61	ERJ6GEYJ681V	1/10W 680	R512	ERJ6GEYJ471V	1/10W 470			
R62	ERJ6GEYJ122V	1/10W 1.2K	R513	ERJ3GEYJ222V	1/16W 2.2K			CHIP JUMPERS
R63	ERJ3GEYJ681V	1/16W 680	R514	ERJ3GEYJ333V	1/16W 33K			
R65	ERJ3GEYJ104V	1/16W 100K	R515	ERJ6GEYJ681V	1/10W 680	R328	ERJ6GEYOR00V	CHIP JUMPER
R66	ERJ6GEYJ3R3V	1/10W 3.3	R523	ERJ6GEYJ102V	1/10W 1K	R410	ERJ6GEYOR00V	CHIP JUMPER
R105	ERJ6GEYJ333V	1/10W 33K	R526	ERJ6GEYJ102V	1/10W 1K	R507	ERJ6GEYOR00V	CHIP JUMPER
R106	ERJ6GEYJ124V	1/10W 120K	R532	ERJ3GEYJ472V	1/16W 4.7K	RJ11	ERJ8GEYOR00V	CHIP JUMPER
R107, 108	ERJ6GEYJ103V	1/10W 10K	R533	ERJ6GEYJ224V	1/10W 220K	RJ301	ERJ6GEYOR00V	CHIP JUMPER
R109	ERJ6GEYJ223V	1/10W 22K	R534	ERJ3GEYJ103V	1/16W 10K	RJ303	ERJ6GEYOR00V	CHIP JUMPER
R110	ERJ6GEYJ124V	1/10W 120K	R601, 602	ERJ3GEYJ681V	1/16W 680	RJ501	ERJ3GEYOR00V	CHIP JUMPER
R111	ERJ6GEYJ102V	1/10W 1K	R603, 604	ERJ3GEYJ561V	1/10W 560	RJ503	ERJ3GEYOR00V	CHIP JUMPER
R112	ERJ6GEYJ103V	1/10W 10K	R605	ERJ6GEYJ473V	1/10W 47K	RJ801, 802	ERJ8GEYOR00V	CHIP JUMPER
R113, 114	ERJ6GEYJ330V	1/10W 33	R606	ERJ3GEYJ473V	1/16W 47K	RJ805	ERJ8GEYOR00V	CHIP JUMPER

Ref. No.	Part No.	Values & Remarks	Ref. No.	Part No.	Values & Remarks			
RJ904	ERJ6GEYOR00V	CHIP JUMPER	C404	ECUVNC105ZFN	16V 1U			
RJ931	ERJ6GEYOR00V	CHIP JUMPER	C406	ECUV1H151JCV	50V 150P			
RJX502	ERJ3GEYOR00V	CHIP JUMPER	C407	ECEA1CKA100I	16V 10U			
RJX901	ERJ3GEYOR00V	CHIP JUMPER	C408	ECUVNC105ZFN	16V 1U			
			C409	ECUV1H151JCV	50V 150P			
		CAPACITORS	C410	ECUV1H471KBV	50V 470P			
			C413, 414	ECUV1H471KBV	50V 470P			
C10	ECUVNE104ZFN	25V 0.1U	C415	ECUVNE104ZFN	25V 0.1U			
C13	RCE0JSL470IX	6.3V 47U	C416	ECUVNC105ZFN	16V 1U			
C14	ECEA0JKA101I	6.3V 100U	C417	ECUV1H471KBN	50V 470P			
C15	ECUV1E103KBN	25V 0.01U	C418	ECUV1H331KBN	50V 330P			
C16, 17	ECEA1VKN2R2I	35V 2.2U	C420	ECUVNC105ZFN	16V 1U			
C18	ECUV1H331KBN	50V 330P	C501, 502	ECUV1H330KCV	50V 33P			
C19	ECUVNE104KBN	25V 0.1U	C503	ECUV1H561KBV	50V 560P			
C20	ECEA1EKA4R7I	25V 4.7U	C504	ECUVNC473KBV	16V 0.047U			
C21	ECUV1E223KBV	25V 0.022U	C505	ECUV1E223KBV	25V 0.022U			
C22	ECUVNE104ZFN	25V 0.1U	C507	ECEA0GKA221	4V 220U			
C24	RCE1ASCAR7IX	10V 4.7U	C508	ECUVNC104ZFN	16V 0.1U			
C25	ECUVNC224KBN	16V 0.22U	C509	ECUV1H470KCV	50V 47P			
C26	ECUV1H331KBV	50V 330P	C510, 511	ECUVNC474KBN	16V 0.47U			
C28	RCE1AMT102BV	10V 1000U	C512	ECUV1E103KBV	25V 0.01U			
C29	ECA1AM331I	10V 330U	C515	ECUV1H332KBV	50V 3300P			
C30	ECUV1H470KCN	50V 47P	C516, 517	ECUVNC104ZFN	16V 0.1U			
C31	ECUVNC224KBN	16V 0.22U	C518	ECUV1E103KBV	25V 0.01U			
C32	ECEA1EKA4R7I	25V 4.7U	C523-525	ECUVNE104ZFN	25V 0.1U			
C51	ECUV1C104KBV	16V 0.1U	C526	ECUVNC104ZFN	16V 0.1U			
C52	ECUVNC104ZFN	16V 0.1U	C527	ECUVNE104ZFN	25V 0.1U			
C101, 102	ECUVNE104KBN	25V 0.1U	C600	ECUVNC104ZFN	16V 0.1U			
C103	ECUV1E273KBN	25V 0.027U	C601, 602	ECUV1H102KBV	50V 1000P			
C104	ECUV1E223KBN	25V 0.022U	C603, 604	ECUV1H272KBV	50V 2700P			
C105	ECUV1C333KBN	16V 0.033U	C605, 606	ECEA1CPK100I	16V 10U			
C106	ECUV1H222KBN	50V 2200P	C607, 608	ECUV1H681KBN	50V 680P			
C107	ECUV1H681KBN	50V 680P	C609	ECUVNC104ZFN	16V 0.1U			
C108	ECUV1C473KBN	16V 0.047U	C610	ECEA0GKA221	4V 220U			
C109	ECUV1C333KBN	16V 0.033U	C611	ECUVNC104ZFN	16V 0.1U			
C110	ECUV1E223KBN	25V 0.022U	C612	ECUVNE104ZFN	25V 0.1U			
C111	ECUV1E273KBN	25V 0.027U	C613	ECEA1CKA220I	16V 22U			
C112	ECUV1H331KBV	50V 330P	C701, 702	ECUV1H332KBV	50V 3300P			
C113, 114	ECUVNE104ZFN	25V 0.1U	C703	ECUV1E123KBV	25V 0.012U			
C115	ECUV1E223KBN	25V 0.022U	C704	ECUV1E123KBN	25V 0.012U			
C116	ECUVNE104KBN	25V 0.1U	C705, 706	ECUV1C333KBV	16V 0.033U			
C117	ECUV1H272KBN	50V 2700P	C707	ECUV1H102KBV	50V 1000P			
C120	ECUV1H331KBV	50V 330P	C708	ECUV1H102KBN	50V 1000P			
C201	RCE0JSL470IX	6.3V 47U	C709, 710	ECEA0GPK221I	4V 220U			
C202	ECUVNC224KBN	16V 0.22U	C711, 712	ECEA1CPK100I	16V 10U			
C203	ECEA1HKA2R2I	50V 2.2U	C713	ECEA0JPK101I	6.3V 100U			
C204	ECUV1H680KCN	50V 68P	C714	ECUVNE104ZFN	25V 0.1U			
C206	ECUV1E103KBN	25V 0.01U	C901	ECUV1H332KBN	50V 3300P			
C207, 208	ECUV1H102KBN	50V 1000P						
C304, 305	ECUVNE104ZFN	25V 0.1U						
C306	ECUVNC105ZFN	16V 1U						
C401-403	ECUV1H471KBV	50V 470P						

REPLACEMENT PARTS LIST

1482

Notes: * Important safety notice:
 Components identified by \triangle mark have special characteristics important for safety.
 Furthermore, special parts which have purposes of fire-retardant (resistors), high-quality sound (capacitors), low-noise (resistors), etc. are used.
 When replacing any of components, be sure to use only manufacturer's specified parts shown in the parts list.
 * The parenthesized indications in the Remarks columns specify the areas. (Refer to the cover page for area.)
 Parts without these indications can be used for all areas.
 * Warning: This product uses a laser diode. Refer to caution statements on page 2.

Ref. No.	Part No.	Part Name & Description	Remarks	Ref. No.	Part No.	Part Name & Description	Remarks
		PACKING MATERIAL		A7*1	RKB205ZA-0	EAR PADS	
				A8	RFA0627-K	BATTERY CASE	
				A9	RFC0041-K	SOFT CASE	
P1	RPK0760	PACKING CASE				<GREASE OR JIG/TOOL>	
P2	RPQ0597	PAD				TEST DISC	
P3	RPF0111	PROTECTION BAG (UNIT)					
P4	RPF0046	PROTECTION BAG (F. B.)		SA1	SZZP1054C	PLAYABILITY TEST DISC	
P5	RQLA0262	PL LABEL	(GK)	SA2	SZZP1056C	UNEVEN TEST DISC	
		ACCESSORIES				GREASE	
A1	RFKSL600GKK	INSTRUCTION MANUAL ASS'Y		SA3	RFKXPG671	MOLYCOAT GREASE PG671	
A2	RFEA401E-3S	AC ADAPTOR	(GK) \triangle			<PRINTED CIRCUIT BOARDS ASS'Y>	
A2	RFEA401E-2S	AC ADAPTOR	(GH) \triangle				
A3	RFEV312P-KS	STEREO EARPHONES		PCB1	REP2237B-M	MAIN P. C. B. ASS'Y	(RTL)
A4	RFEV004PCKS	REMOTE CONTROL		PCB2	REP2238B-S	OPERATION P. C. B. ASS'Y	(RTL)
A5	RQCB0169	SERVICENTER LIST					
A6	RP-BP60SYS2	RECHARGEABLE BATTERIES					
A6-1	RFKNLS370-K	BATTERY CARRYING CASE					

The marked items (RTL) will be in stock for a limited period. These items will be provided only in a specified period after the discontinuance of production. Valid period will differ depending on types of parts, and accord with the concerned regulations about parts and products in stock.

*1: This item can be provided only when listed on the replaceable part list.

PACKAGING

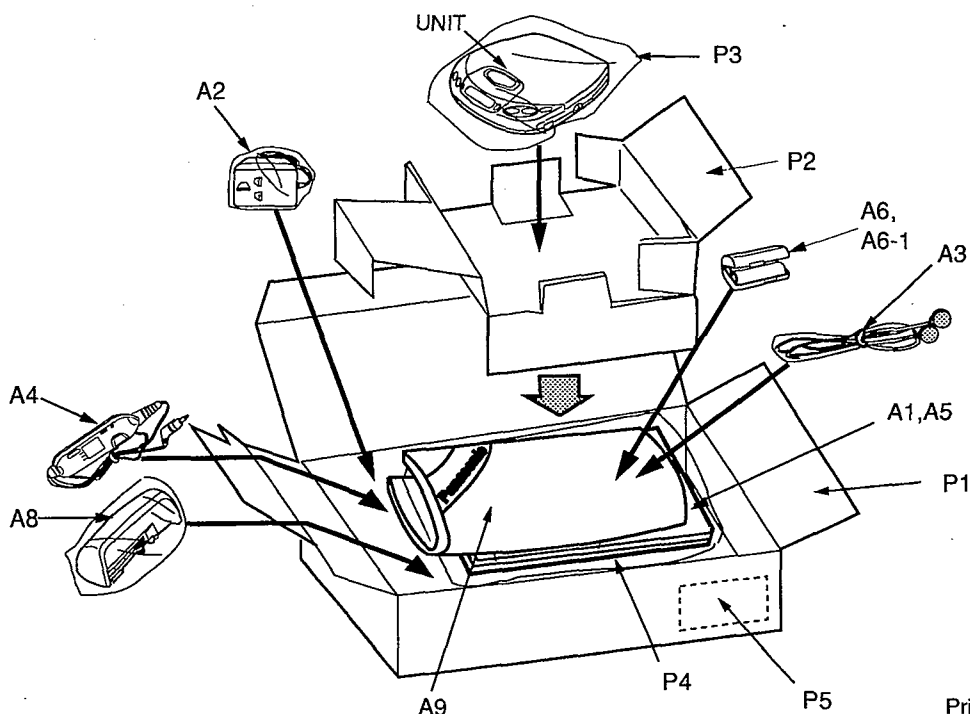

Printed in Japan
K970200300MK/HH